



KOMdrive Feed-out tools

for Special-Purpose Machines

CERATIZIT is a high-technology engineering group specialised in cutting tools and hard material solutions.

Tooling a Sustainable Future

ceratizit.com



CERATIZIT
GROUP

KOMdrive – High-precision feed out tools for special-purpose machines

Unbeatable precision combined with a long service life

The slides of the facing heads are actuated mechanically through precision ground serrated rack components designed with maximum engagement of the teeth. The radial stroke is limited through fine adjustable internal stops for safety reasons. Sliding parts are made of long-term nitrided steel with high surface hardness and low friction properties.

Your Technical Sales Engineer will be happy to answer any further questions or please contact directly

Offer.Actuatingtools@ceratizit.com

Advantages

- ▲ Low coefficient of friction through special surface treatment of the sliding components
- ▲ Minimal backlash in the μm range
- ▲ Compact slide designs including integrated ABS connections for highest rigidity and metal removal
- ▲ High spindle speeds without compromising machining accuracy or service life
- ▲ Precision manufacturing processes and extensive research and development warrant the highest technological level

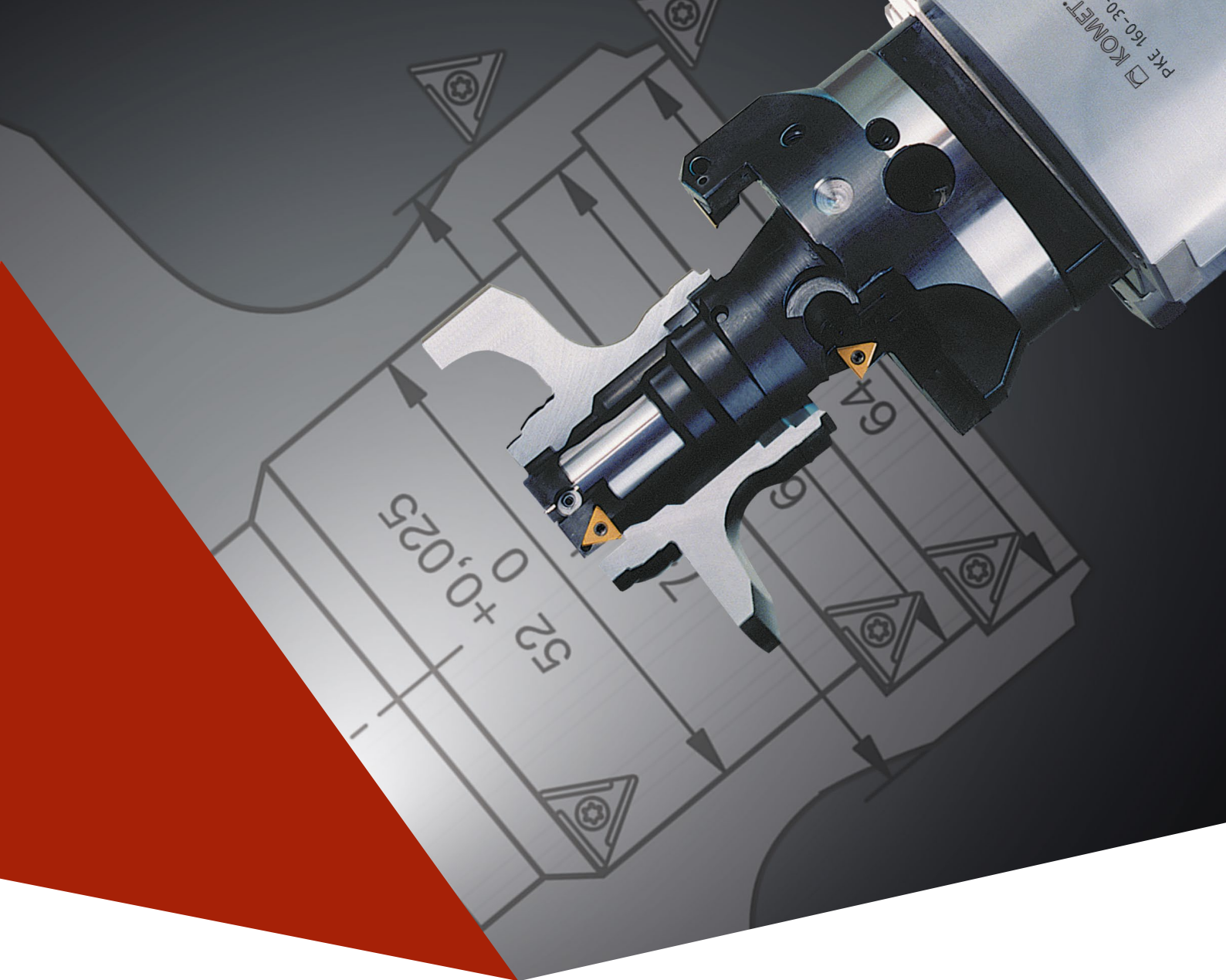

Machining examples

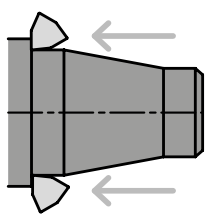

Contour machining

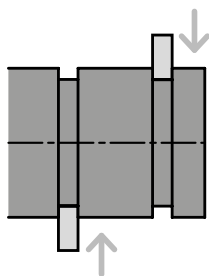

External grooving

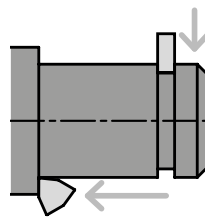

Grooving and facing

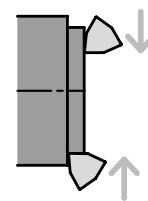

Face turning towards center

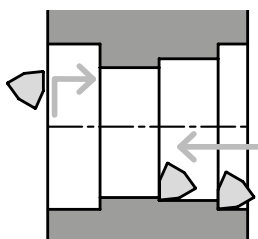

Boring and facing

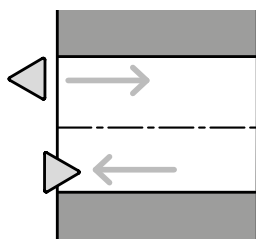

Internal Machining

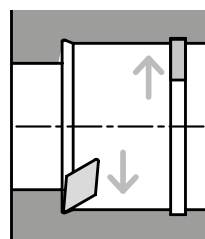

Facing and grooving

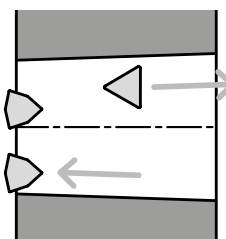

Drilling taper and boring

KOMdrive PKE

Facing head with single slide for low spindle speeds

- ▲ Very attractive price
- ▲ Available ex stock
- ▲ Increased service life thanks to the surface-treated gear parts
- ▲ Can be used on transfer lines, special purpose machines and automatic rotary indexing machines
- ▲ Can be adapted to almost any spindle using the intermediate flange



KOMdrive PKD

Facing head with double slide for medium to high spindle speeds (depending on size of facing head)

- ▲ Design-dependently balanced system
- ▲ Long service life thanks to large toothings surfaceche
- ▲ Significant cycle time reduction due to twin cutting and higher rpm



KOMdrive PKU

Counterweighted facing head for medium to high spindle speeds (depending on size of facing head)

PKU balanced facing heads are suitable for the highest spindle speeds. The tool mounting areas are similar to the facing heads with a single slide, and offer optimum tooling rigidity. The facing heads may be furnished with an additional tool guide for heavy duty machining conditions. Please note that the weight of the front tools is limited for this series of facing heads (see page 24).

Balancing note: Balancing of these facing heads is achieved in any slide position through the weighting of the sliding components. The snap-on tools are involved in this dynamic and must therefore be adjusted in respect of weight and centre of gravity (see column „weight“), i.e. facing heads are finely balanced with the snap-on tools.

- ▲ Cycle time reduction through higher rotation speed ranges
- ▲ Optimally balanced system due to balancing weight adjusted to tool weight
- ▲ Available in different versions for optimum process
- ▲ Facing heads with short stroke are suitable for: Internal machining (grooving, under-cutting and boring) with heavy front tools.

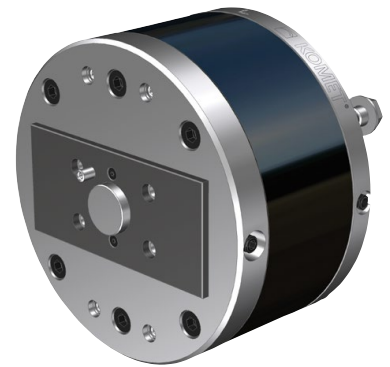

Index

KOMdrive PKE	6 – 15
PKE-101 Facing head with single slide with mounting holes in slide	6 – 7
PKE-101 Facing head with single slide with mounting holes in slide with internal coolant supply	8 – 9
PKE-103 Facing head with single slide with integrated ABS-N connection	10 – 11
PKE-104 Facing head with single slide with integrated SBA connection	12 – 13
Adaptor with ABS-N connection	14
Technical notes	15
KOMdrive PKD	16 – 19
PKD-101 Facing head with double slide with mounting holes in slide	16 – 17
Adaptor with ABS-N connection	18
Technical notes	19
KOMdrive PKU	20 – 24
PKU-101 Facing head with counterweighted with mounting holes in slide	20 – 21
PKU-103 Facing head with counterweighted with integrated ABS-N connection	22 – 23
Technical notes	24
KOMdrive Adaptor flange	25
Assembly variants	26 – 27
Machining examples	28 – 31
Modified facing heads	32
KOMtronic U-axis systems for special purpose machines	33
KOMlife – Autonomous acquisition of production data accurate to the second	34 – 35

KOMdrive PKE-101 / PKE-101-QA

Facing head with single slide with mounting holes in slide

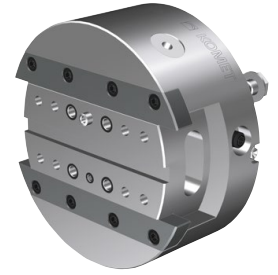

Adaptor with
ABS-N connection
→ 14

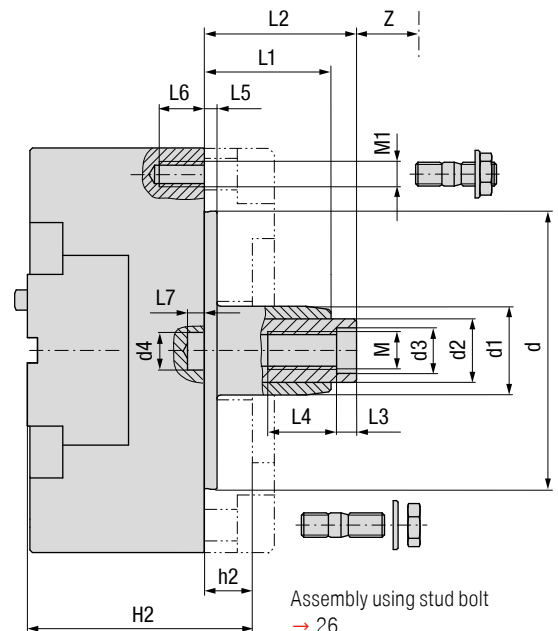
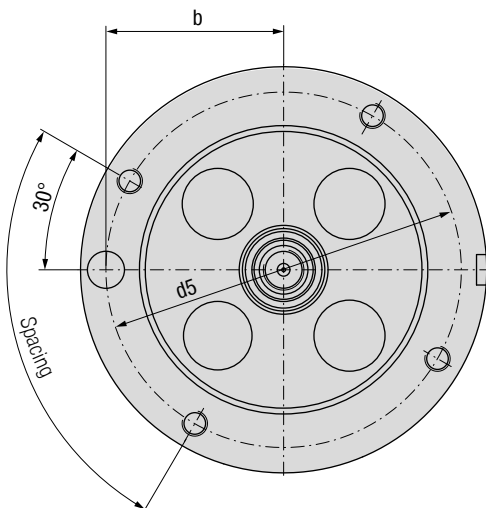
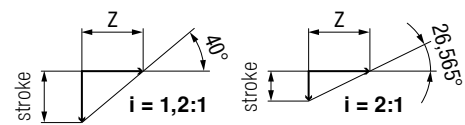
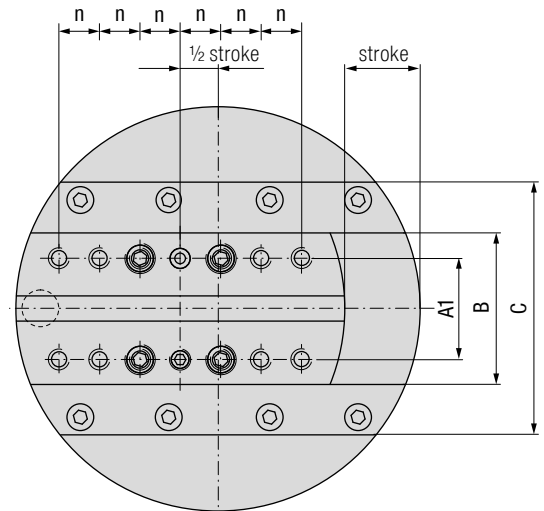
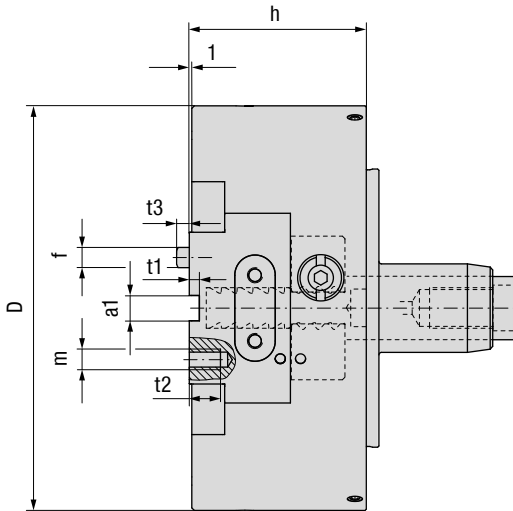

Assembly using stud bolt
→ 26
Adaptor flange for spindle
according to DIN 2079
→ 25

External dimensions												
Description	KOMET No. Article No.	D _{h6} mm	Stroke mm	i Traduction	Pitch	Z mm	h mm	d _{h6} mm	d1 mm	d2 mm	d3 ^{H7} mm	d4 ^{+0,1} mm
PKE 80-12-101	P01 00010	80	12	1,2 : 1		14,3	42	50	25	16	12	10,3
PKE 100-17-101 QA	P01 10011 60 000 10017	100	17	1,2 : 1	40°	20,3	50	65	25	16	12	10,3
PKE 100-10-101 QA 2:1	P01 10016 60 000 10010		10	2 : 1	26,565°							
PKE 125-22-101 QA	P01 20011 60 000 12522	125	22	1,2 : 1	40°	26,2	58	90	30	20	14	14,6
PKE 125-13-101 QA 2:1	P01 20016 60 000 12513		13	2 : 1	26,565°							
PKE 160-30-101 QA	P01 30011 60 000 16030	160	30	1,2 : 1	40°	35,7	70	110	35	25	18	14,6
PKE 160-18-101 QA 2:1	P01 30016 60 000 16018		18	2 : 1	26,565°							
PKE 200-40-101 QA	P01 40011	200	40	1,2 : 1	40°	47,7	85	150	44	32	18	16,2
PKE 200-24-101 QA 2:1	P01 40016		24	2 : 1	26,565°							
PKE 250-50-101 QA	P01 50011	250	50	1,2 : 1	40°	59,6	100	180	46	32	18	19,4
PKE 250-30-101 QA 2:1	P01 50016		30	2 : 1	26,565°							

Slide dimensions										
Size	B mm	C mm	A1 mm	a1 ^{H8} mm	t1 mm	t2 mm	m	f _{m6} mm	n mm	No. of bolt holes
PKE 80	36	-	22	8	3	10	M6	6	12	8
PKE 100	40	72	26	8	3	10	M6	6	11	12
PKE 125	50	86	32	10	4	12	M8	8	13	12
PKE 160	60	100	40	10	4	12	M8	8	16	12
PKE 200	80	130	55	12	4	15	M10	10	20	12
PKE 250	100	150	70	12	4	18	M12	12	20	16

Mounting dimensions															
Size	M	M1	L1 mm	L2±1 mm	L3 mm	L4 mm	L5 mm	L6 mm	L7 mm	b±0,1 mm	d5 mm	Spacing	H2 mm	h2 mm	Spindle size DIN 2079
PKE 80	M10×1L	M6	28	38	8	14	4	10	5	32	68	4×90° 3×120°	60	18	30
PKE 100	M10×1L	M8	30	40	8	14	4	12	5	42	84	4×90° 3×120°	65	15	30
PKE 125	M12×1,5L	M8	37	47	8	16	4	12	6	54	110	6×60°	75	17	40
PKE 160	M16×1,5L	M10	50	60	10	25	5	15	6	70	140	4×90°	90	20	40
PKE 200	M16×1,5L	M12	70	80	10	25	5	18	6	87,5	175	4×90°	110	25	50
PKE 250	M16×1,5L	M16	90	100	10	25	6	22	6	108	216	4×90°	125	25	50

Order example:

Facing head Ø 100 mm / stroke 17 mm / type 101 QA: Description PKE100-17-101QA / KOMET No. P01 10011 or Article-Nr. 60 000 10017

PKE size 320 / 400 / 500 on request.



Article no. 60.... available from stock

KOMdrive PKE-101-QA-IK-F-BR

Facing head with single slide with mounting holes in slide

- ▲ with internal coolant supply
- ▲ additional mounting option on the housing, e.g. a bridge



Assembly using cylindrical screws
→ 27
PKE 125: M10x60
PKE 160: M10x80

Bridge with ABS connection
→ 9

Adaptor with ABS-N connection
→ 14

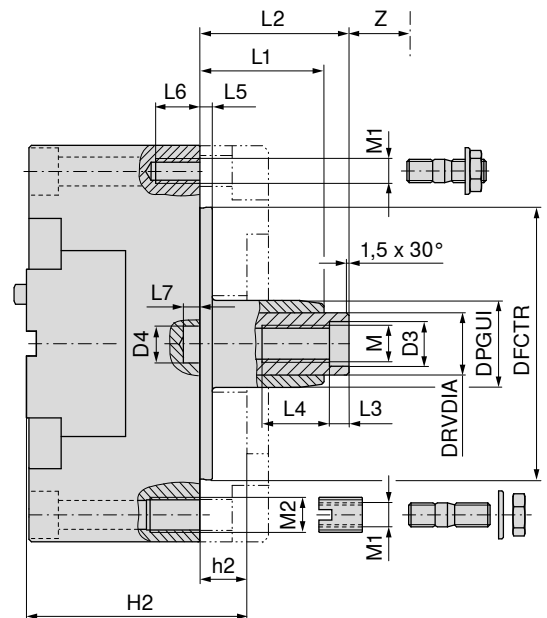
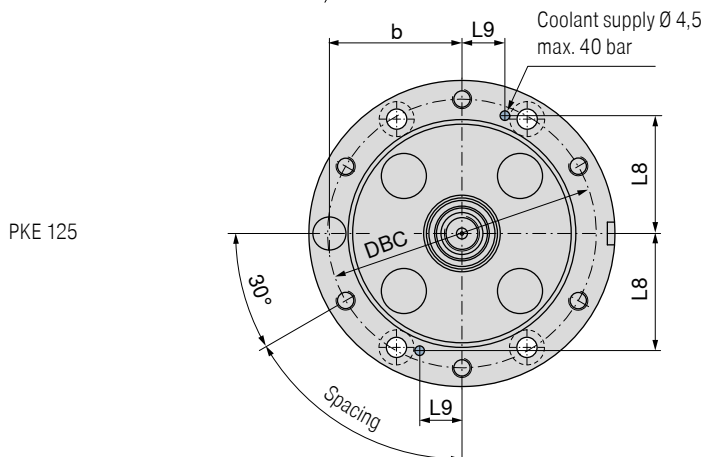
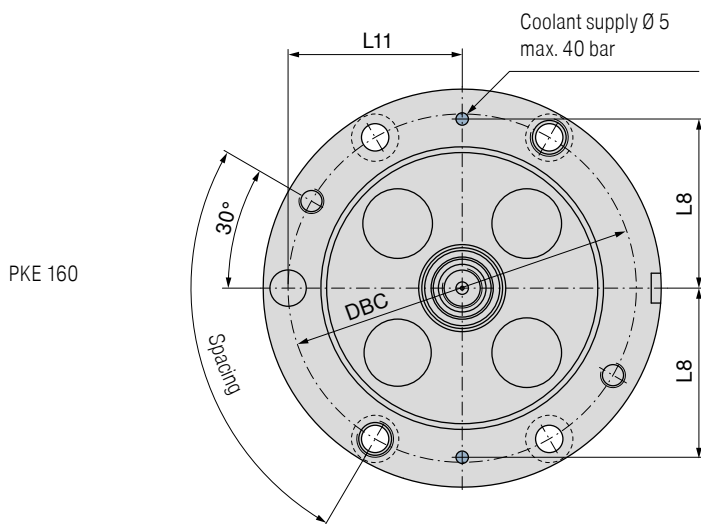
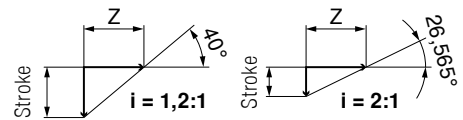
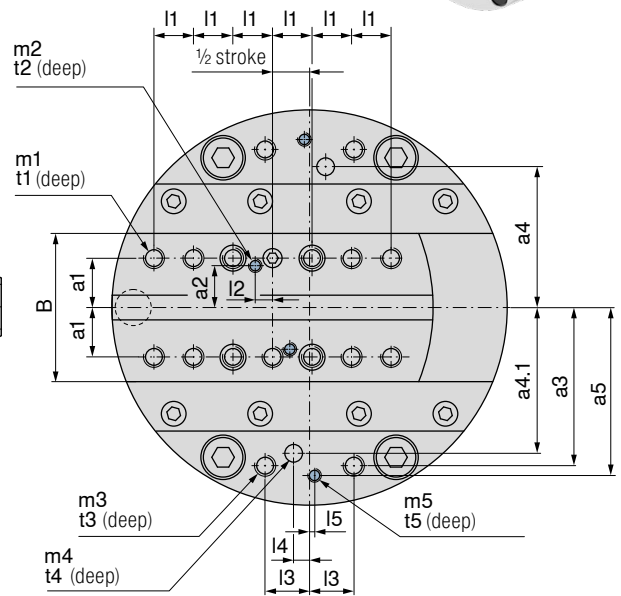
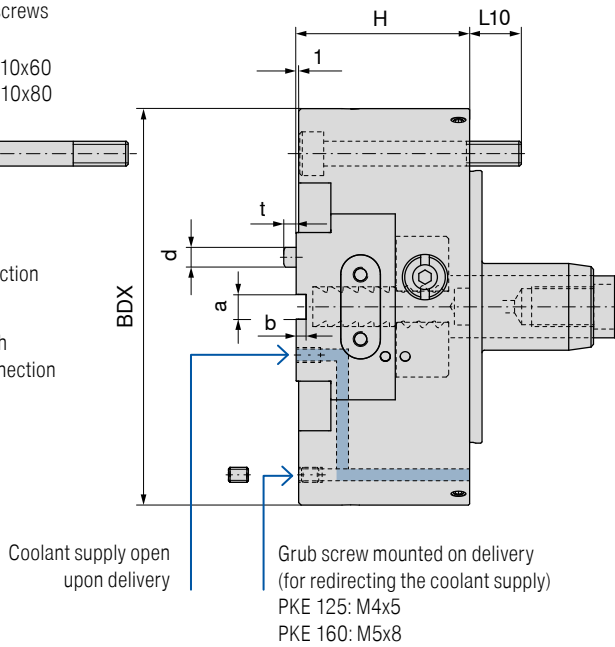

- Assembly using stud bolt
→ 26
- Assembly using threaded insert/
stud bolt (PKE 160)
→ 26
- Adaptor flange for spindle
according to DIN 2079
(without coolant supply)
→ 25

External dimensions													
Description	Article No. KOMET No.	BDX _{h6} mm	Stroke mm	i Traduction Pitch		Z mm	H mm	DFCTR _{h6} mm	DPGUI mm	DRVDIA mm	D3 ^{H7} mm	d4 ^{+0.1} mm	
PKE 125-22-101 QA.IK.F.BR	60 001 22522 P01 20020	125	22	1,2 : 1	40°	26,2	58	90	30	20	14	14,6	
PKE 125-13-101 QA.IK.F.BR	60 001 22513 P01 20120		13	2 : 1	26,565°	26							
PKE 160-30-101 QA.IK.F.BR	60 001 26030 P01 30020	160	30	1,2 : 1	40°	35,7	70	110	35	25	18	14,6	
PKE 160-18-101 QA.IK.F.BR	60 001 26018 P01 30120		18	2 : 1	26,565°	36							

Slide dimensions														
Size	B mm	Slot		Location hole				Coolant transfer				Positioning pin		No. of bolt holes
		a ^{H8} mm	b mm	a1 mm	l1 mm	m1 mm	t1 mm	a2 mm	l2 mm	m2 mm	t2 mm	d _{m6} mm	t mm	
PKE 125	50	10	4	16	13	M8	12	10,5	6,5	M4	5	8	5	12
PKE 160	60	10	4	20	16	M8	12	= a1	7	M5	6	8	5	12

Mounting dimensions – Bridge													
Size	Location hole				Coolant transfer				Positioning pin				
	a3 mm	l3 mm	m3 mm	t3 mm	a5 mm	l5 mm	m5 mm	t5 mm	a4 mm	a4.1 mm	l4 mm	m4±0.05 mm	t4 mm
PKE 125	53	13,5	M6	10	47,85	3,77	M4	7	53	54,5	3	6,15	8
PKE 160	64	18	M8	16	68	0	M5	10	57	59	6,5	7,15	9

Mounting dimensions																			
Size	M	M1	M2	L1	L2±1	L3	L4	L5	L6	L7	L8	L9	L10	L11±0.1	DBC	Spacing	H2	h2	Spindle size DIN 2079
				mm	mm	mm	mm	mm	mm	mm	mm	mm	mm	mm	mm	mm	mm	mm	
PKE 125	M12×1,5L	M8	-	37	47	8	16	4	12	6	47	17	14,5	54	110	6×60°	75	17	40
PKE 160	M16×1,5L	M10	M14×1,5	50	60	10	25	5	15	6	68	-	22	70	140	4×90°	90	20	40

Order example:

Facing head Ø 125 mm / stroke 22 mm / type 101 QA.IK.F.BR: Description PKE 125-22-101 QA.IK.F.BR / KOMET No. P01 20020 or Article-Nr. 60 001 22522



Facing head **Article no. 60 001** available from stock

Bridge with ABS connection						
Description	Article No. KOMET No.	SZID	BD	DCONWS	LSC	LPR
BR.PKE 125-ABS40	60 006 12500 P80 24050	ABS40	40	20	29	45
BR.PKE 160-ABS50	60 006 16000 P80 35050	ABS50	50	28	39	60

For redirecting the coolant supply, remove the grub screw on the housing and close the coolant holes on the slider.

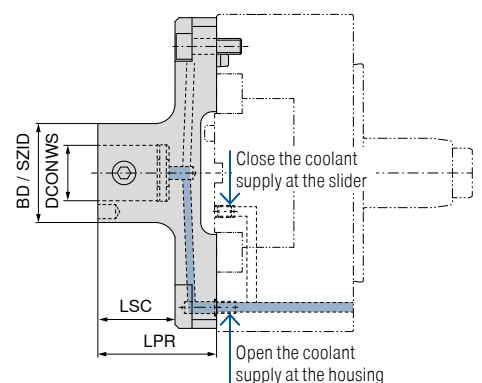

KOMdrive PKE-103 / PKE-103-QA

Facing head with single slide with integrated ABS-N connection

on request

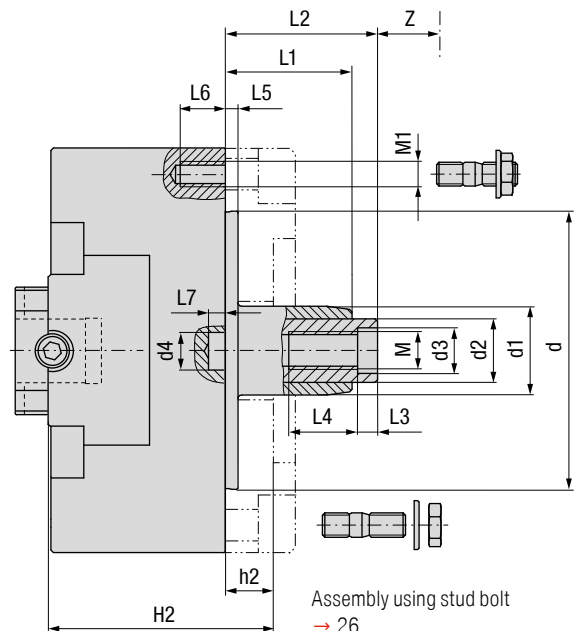
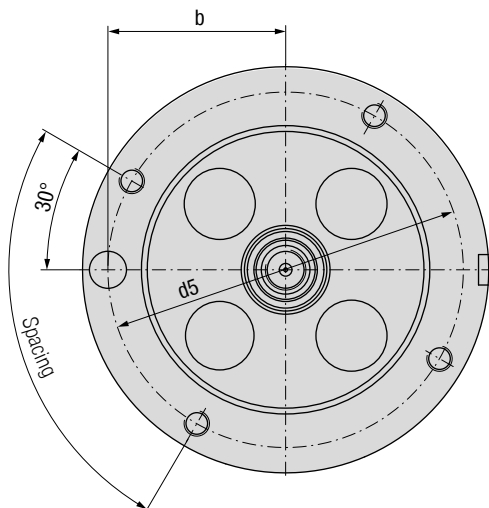
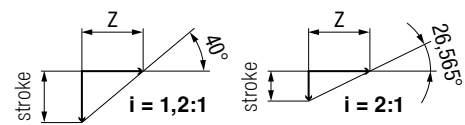
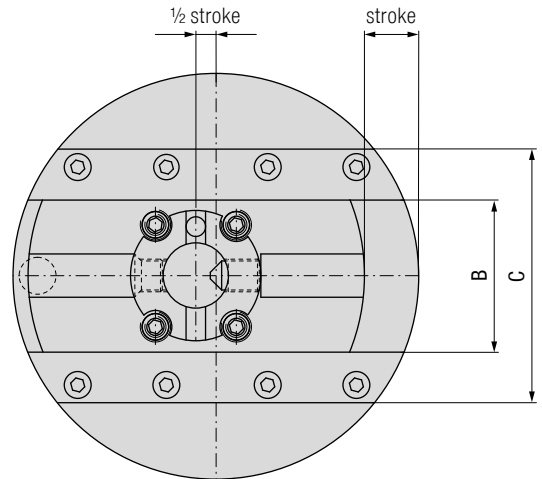
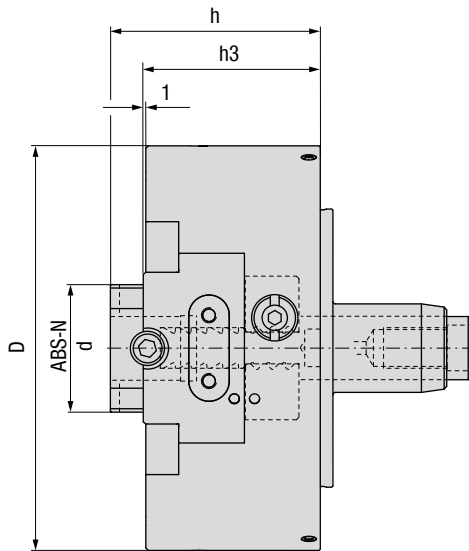

Assembly using stud bolt
→ 26
Adaptor flange for spindle
according to DIN 2079
→ 25

External dimensions													
Description	KOMET No.	D _{h6} mm	Stroke mm	i Traduction	Pitch	Z mm	h mm	h3 mm	d _{h6} mm	d1 mm	d2 mm	d3 ^{H7} mm	d4 ^{+0,1} mm
PKE 80-6-103	P01 00030	80	6	1,2 : 1		7,2	52	42	50	25	16	12	10,3
PKE 100-10-103 QA	P01 10031	100	10	1,2 : 1	40°	11,9	60	50	65	25	16	12	10,3
PKE 100-6-103 QA 2:1	P01 10036		6	2 : 1	26,565°								
PKE 125-12-103 QA	P01 20031	125	12	1,2 : 1	40°	14,3	68	58	90	30	20	14	14,6
PKE 125-7-103 QA 2:1	P01 20036		7	2 : 1	26,565°								
PKE 160-15-103 QA	P01 30031	160	15	1,2 : 1	40°	17,9	85	70	110	35	25	18	14,6
PKE 160-9-103 QA 2:1	P01 30036		9	2 : 1	26,565°								
PKE 200-20-103 QA	P01 40031	200	20	1,2 : 1	40°	23,8	100	85	150	44	32	18	16,2
PKE 200-12-103 QA 2:1	P01 40036		12	2 : 1	26,565°								
PKE 250-30-103	P01 50030	250	30	2 : 1		35,7	120	100	180	46	32	18	19,4

Slide dimensions			
Size	B mm	C mm	d ABS-N
PKE 80	36	-	32
PKE 100	40	72	32
PKE 125	50	86	40
PKE 160	60	100	50
PKE 200	80	130	63
PKE 250	100	150	80

Mounting dimensions															
Size	M	M1	L1 mm	L2±1 mm	L3 mm	L4 mm	L5 mm	L6 mm	L7 mm	b±0,1 mm	d5 mm	Spacing	H2 mm	h2 mm	Spindle size DIN 2079
PKE 80	M10×1L	M6	28	38	8	14	4	10	5	32	68	4×90° 3×120°	70	18	30
PKE 100	M10×1L	M8	30	40	8	14	4	12	5	42	84	4×90° 3×120°	75	15	30
PKE 125	M12×1,5L	M8	37	47	8	16	4	12	6	54	110	6×60°	85	17	40
PKE 160	M16×1,5L	M10	50	60	10	25	5	15	6	70	140	4×90°	105	20	40
PKE 200	M16×1,5L	M12	70	80	10	25	5	18	6	87,5	175	4×90°	125	25	50
PKE 250	M16×1,5L	M16	90	100	10	25	6	22	6	108	216	4×90°	145	25	50

Order example:

Facing head Ø 250 mm / stroke 30 mm / type 103: Description PKE250-30-103 / KOMET No. P01 50030

KOMdrive PKE-104 / PKE-104-QA

Facing head with single slide with integrated SBA connection

on request

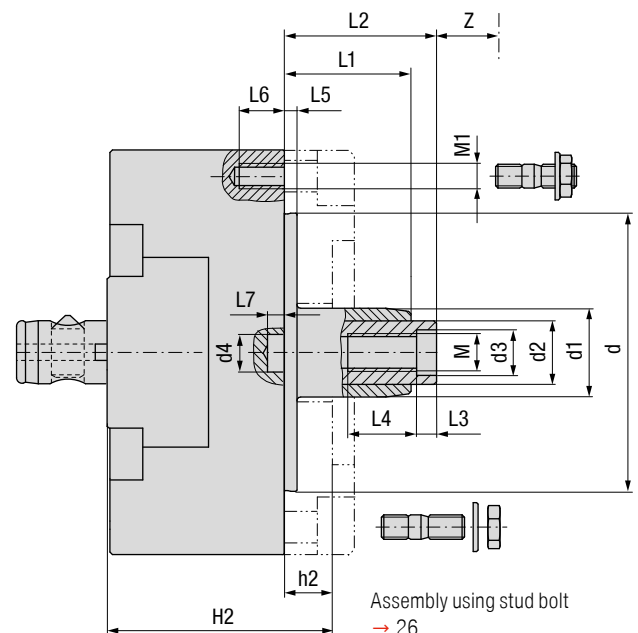
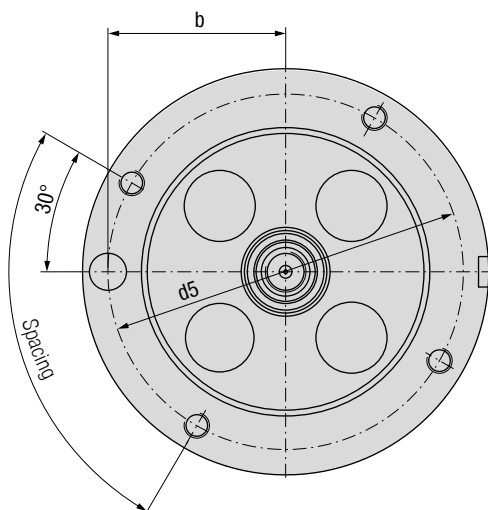
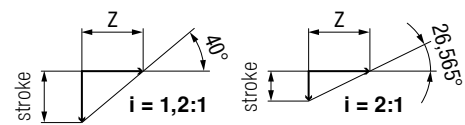
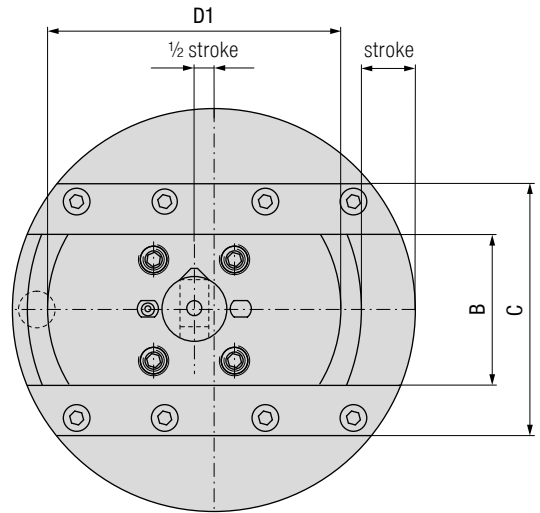
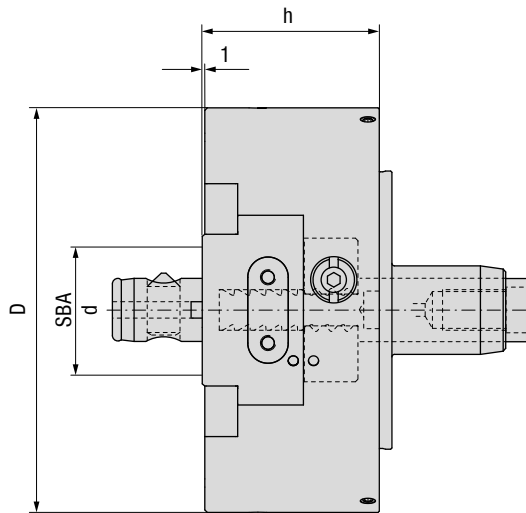

Assembly using stud bolt
→ 26
Adaptor flange for spindle
according to DIN 2079
→ 25

External dimensions												
Description	KOMET No.	D _{ns} mm	Stroke mm	i Traduction	Pitch	Z mm	h mm	d _{ns} mm	d1 mm	d2 mm	d3 ^{H7} mm	d4 ^{+0,1} mm
PKE 80-12-104	P01 00040	80	12	1,2 : 1		14,3	42	50	25	16	12	10,3
PKE 100-15-104 QA	P01 10041	100	15	1,2 : 1	40°	17,9	50	65	25	16	12	10,3
PKE 100-9-104 QA 2:1	P01 10046		9	2 : 1	26,565°							
PKE 125-20-104 QA	P01 20041	125	20	1,2 : 1	40°	23,8	58	90	30	20	14	14,6
PKE 125-12-104 QA 2:1	P01 20046		12	2 : 1	26,565°							
PKE 160-25-104 QA	P01 30041	160	25	1,2 : 1	40°	29,8	70	110	35	25	18	14,6
PKE 160-15-104 QA 2:1	P01 30046		15	2 : 1	26,565°							
PKE 200-30-104 QA	P01 40041	200	30	1,2 : 1	40°	35,7	85	150	44	32	18	16,2
PKE 200-18-104 QA 2:1	P01 40046		18	2 : 1	26,565°							
PKE 250-40-104	P01 50040	250	40	2 : 1		47,7	100	180	46	32	18	19,4
PKE 320-55-104	P01 60040	320	55	2 : 1		65,6	124	220	63	40	22	24,2

Slide dimensions				
Size	B mm	C mm	D1 mm	d SBA
PKE 80	36	-	60	32
PKE 100	40	72	75	40
PKE 125	50	86	95	50
PKE 160	60	100	115	63
PKE 200	80	130	140	80
PKE 250	100	150	170	100
PKE 320	110	178	200	100

Mounting dimensions															
Size	M	M1	L1 mm	L2±1 mm	L3 mm	L4 mm	L5 mm	L6 mm	L7 mm	b±0,1 mm	d5 mm	Spacing	H2 mm	h2 mm	Spindle size DIN 2079
PKE 80	M10×1L	M6	28	38	8	14	4	10	5	32	68	4×90° 3×120°	60	18	30
PKE 100	M10×1L	M8	30	40	8	14	4	12	5	42	84	4×90° 3×120°	65	15	30
PKE 125	M12×1,5L	M8	37	47	8	16	4	12	6	54	110	6×60°	75	17	40
PKE 160	M16×1,5L	M10	50	60	10	25	5	15	6	70	140	4×90°	90	20	40
PKE 200	M16×1,5L	M12	70	80	10	25	5	18	6	87,5	175	4×90°	110	25	50
PKE 250	M16×1,5L	M16	90	100	10	25	6	22	6	108	216	4×90°	125	25	50
PKE 320	M20×1,5L	M16	106	116	10	30	6	22	8	137,5	275	6×60°	150	26	60

Order example:

Facing head Ø 250 mm / stroke 40 mm / type 104: Description PKE250-40-104 / KOMET No. P01 50040

KOMdrive PKE-101 / PKE-101-QA

Adaptor with ABS-N connection

without internal coolant supply

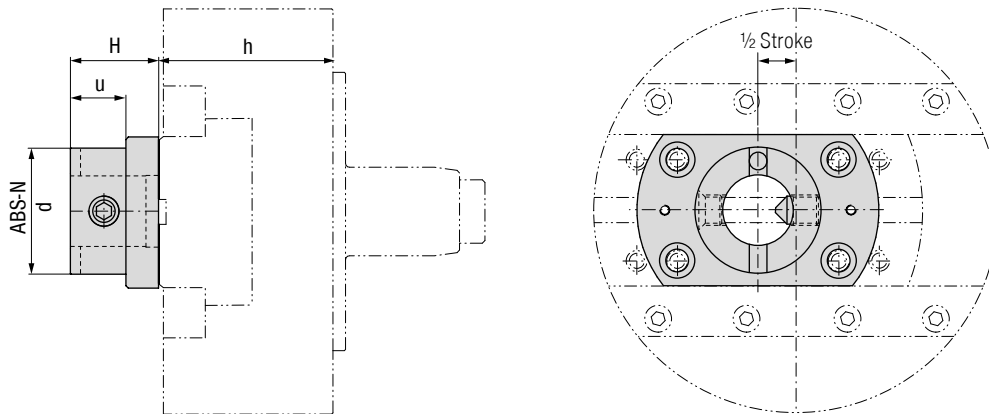

ABS-N Adaptor					
Size	KOMET No.	d ABS-N	H mm	u mm	h mm
PKE 80-...-101	P80 03010	32	25	15	42
PKE100-...-101	P80 13010	32	25	15	50
PKE125-...-101	P80 24010	40	30	17	58
PKE160-...-101	P80 35010	50	35	22	70
PKE200-...-101	P80 46010	63	40	24	85
PKE250-...-101	P80 57010	80	45	25	100
PKE320-...-101	P80 68010	100	60	40	124

KOMdrive PKE-... / PKE-...-QA

Technical notes

Stroke/spindle speed diagram

***max. weight of front tool

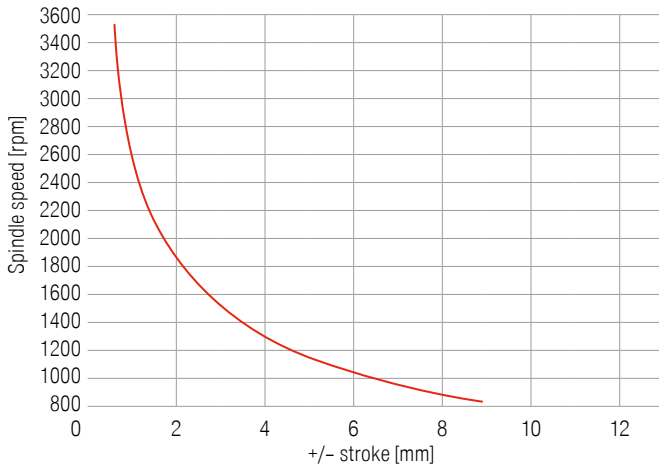

Drawbar force

Full max. stroke

The diagram serves as a guideline. A specific calculation can be produced with consideration to all parameters.

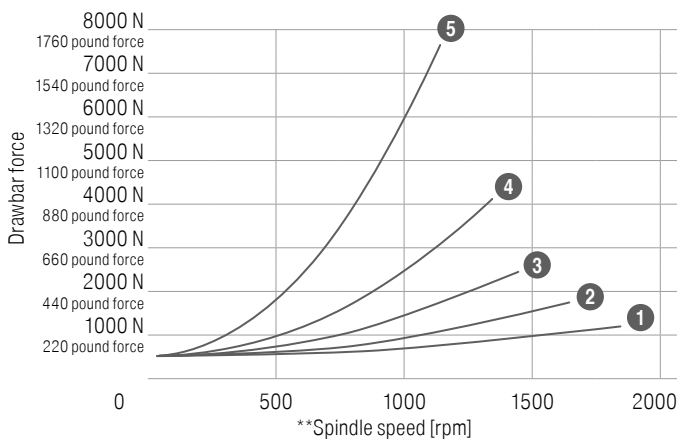

Lubrication requirements

Slide movement: 150 m / 6,000 in. (corresponds to one shift, 8 h)

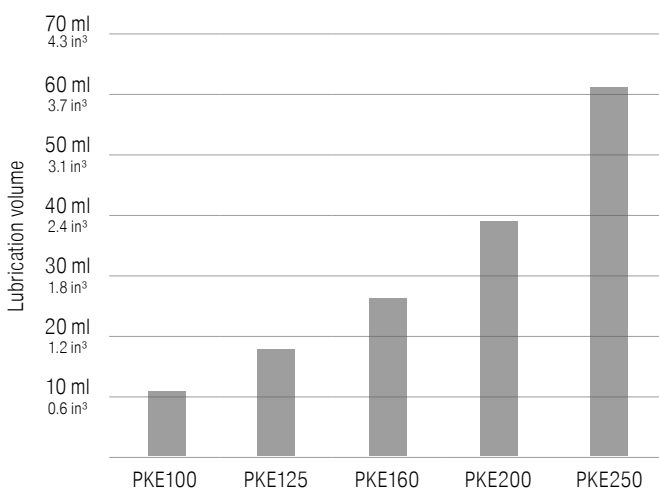

The maximum spindle speed is estimated as follows:

$$r.p.m._{max} = \frac{2500}{\sqrt{\text{stroke}^*}}$$

* stroke in mm from /to rotational axis

** Spindle speed [rpm]

Drawbar forces shown are valid for maximum weight of front tool.

***max. weight of front tool

1	PKE100	1,2 kg	2.6 lbs
2	PKE125	2,0 kg	4.4 lbs
3	PKE160	3,2 kg	7.1 lbs
4	PKE200	5,5 kg	12.1 lbs
5	PKE250	12,0 kg	26.5 lbs

Lubrication volume required for one shift

The values specified are guide values and must, where required, be adjusted to the application conditions such as rotation speed, stroke and environmental influences such as coolant, dirt, etc.

Lubricants

We recommend Mobilux EP004 liquid grease for all speed ranges. Furthermore, it is also possible to use slideway oils according to DIN 51502 with the identifier CG-L68 or CG-L220 (CG-L220 is preferred for speeds from 700 rpm).

The relevant commercial names of the mineral oil companies for slide-way oils can be ascertained from the machine lubrication instructions. These lubrication instructions apply to all generating tools supplied by KOMET.

KOMdrive PKD-101

Facing head with double slide with mounting holes in slides

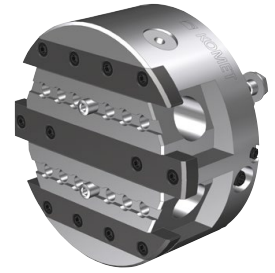

Adaptor with
ABS-N connection
→ 18

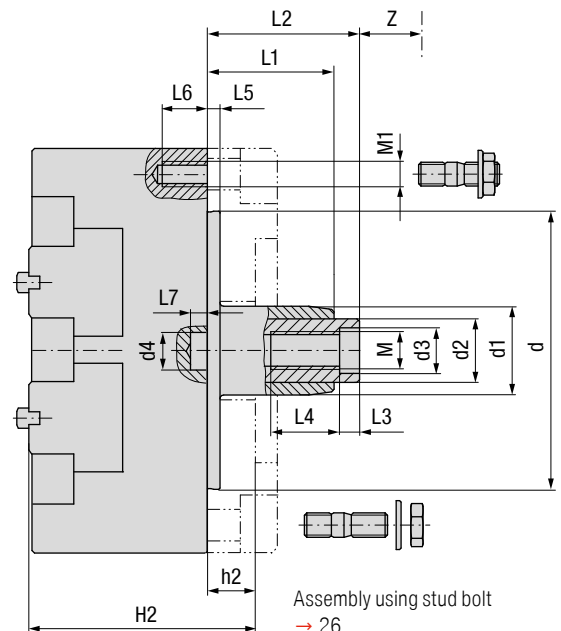
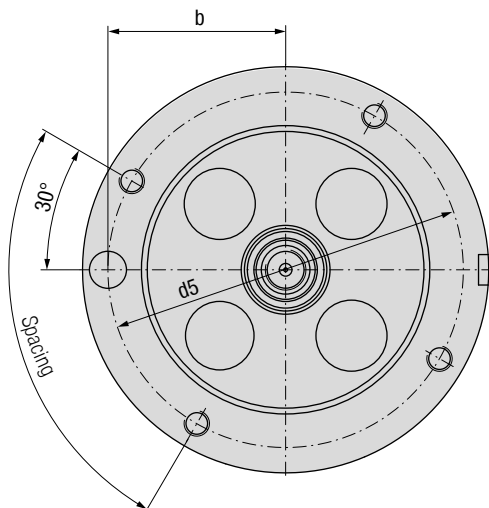
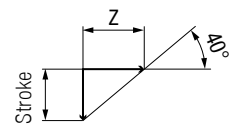
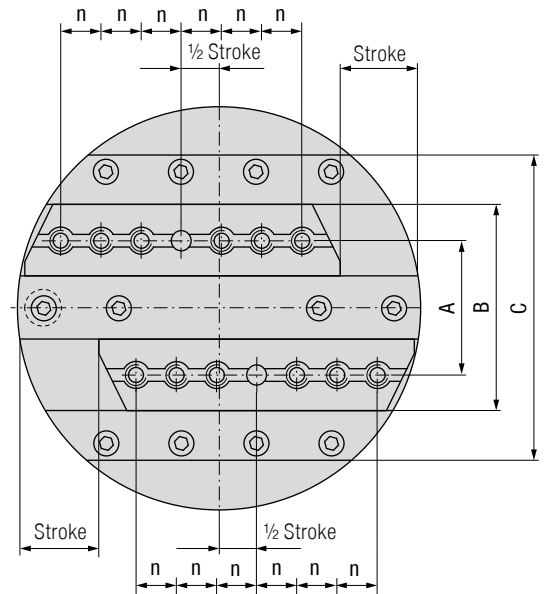
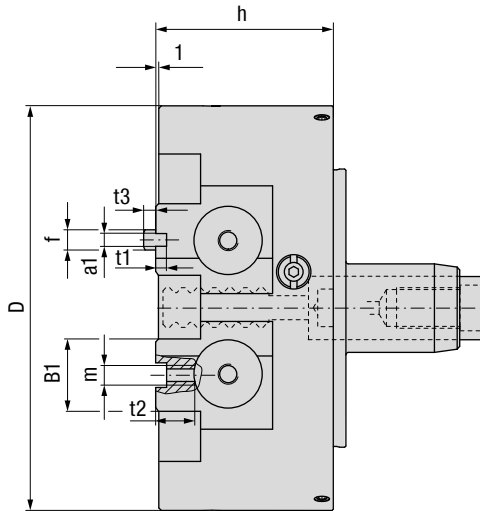

Assembly using stud bolt
→ 26
Adaptor flange for spindle
according to DIN 2079
→ 25

External dimensions										
Description	KOMET No. Article No.	D _{h6} mm	Stroke mm	Z mm	h mm	d _{h6} mm	d1 mm	d2 mm	d3 ^{H7} mm	d4 ^{+0,1} mm
PKD 80-12-101	P05 00010 60 002 08012	80	12	14,3	42	50	25	16	12	10,3
PKD 100-17-101	P05 10010 60 002 10017	100	17	20,3	50	65	25	16	12	10,3
PKD 125-22-101	P05 20010 60 002 12522	125	22	26,2	58	90	30	20	14	14,6
PKD 160-30-101	P05 30010 60 002 16030	160	30	35,7	70	110	35	25	18	14,6
PKD 200-40-101	P05 40010	200	40	47,7	85	150	44	32	18	16,2
PKD 250-50-101	P05 50010	250	50	59,6	100	180	46	32	18	19,4
PKD 320-63-101	P05 60010	320	63	75,1	124	220	63	40	22	24,2

Slide dimensions											
Size	B mm	B1 mm	C mm	A mm	a1 ^{H8} mm	t1 mm	t2 mm	m	f _{m6} mm	n mm	No. of bolt holes
PKD 80	46	15	-	30	6	3	10	M6	6	12	4
PKD 100	56	20	-	36	8	3	15	M8	8	10	6
PKD 125	72	26	-	46	8	3	15	M8	8	12	6
PKD 160	84	30	124	56	8	3	16	M10	10	15	6
PKD 200	102	36	148	64	8	3	16	M10	10	20	6
PKD 250	136	50	186	78	10	4	18	M12	12	20	8
PKD 320	166	60	226	106	12	4	25	M16	16	25	8

Mounting dimensions															
Size	M	M1	L1 mm	L2±1 mm	L3 mm	L4 mm	L5 mm	L6 mm	L7 mm	b±0,1 mm	d5 mm	Spacing	H2 mm	h2 mm	Spindle size DIN 2079
PKD 80	M10×1L	M6	28	38	8	14	4	10	5	32	68	4×90° 3×120°	-	-	30
PKD 100	M10×1L	M8	30	40	8	14	4	12	5	42	84	4×90° 3×120°	65	15	30
PKD 125	M12×1,5L	M8	37	47	8	16	4	12	6	54	110	6×60°	75	17	40
PKD 160	M16×1,5L	M10	50	60	10	25	5	15	6	70	140	4×90°	90	20	40
PKD 200	M16×1,5L	M12	70	80	10	25	5	18	6	87,5	175	4×90°	110	25	50
PKD 250	M16×1,5L	M16	90	100	10	25	6	22	6	108	216	4×90°	125	25	50
PKD 320	M20×1,5L	M16	106	116	10	30	6	22	8	137,5	275	6×60°	150	26	60

Order example:

Facing head Ø 160 mm / stroke 30 mm / type 101: Description PKD 160-30-101 / KOMET No. P05 30010 or Article-Nr. 60 002 16030



Article no. 60.... available from stock

KOMdrive PKD-101

Adaptor with ABS-N connection

* ABS-N adaptors have two key ways for radial positioning

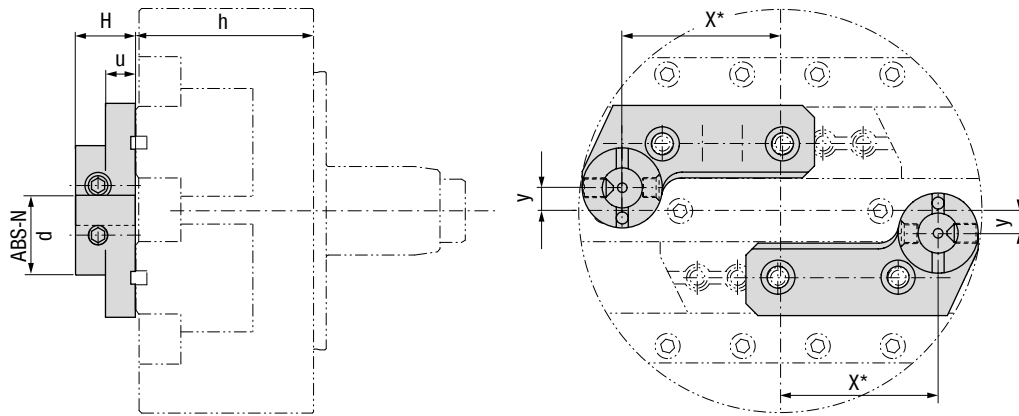

ABS-N Adaptor							
Size	KOMET No.	d ABS-N	H mm	u mm	h mm	X* mm	y mm
PKD 80-...-101	-						
PKD100-...-101	P80 12050	25	25	12	50	35	7
PKD125-...-101	P80 22050	25	25	12	58	47	35
PKD160-...-101	P80 33050	32	25	10	70	60	45
PKD200-...-101	P80 44050	40	30	15	85	80	60
PKD250-...-101	P80 55050	50	35	15	100	100	80
PKD320-...-101	P80 66050	63	40	15	124	125	100

KOMdrive PKD-...

Technical notes

Drawbar force

stroke = start position

The diagram serves as a guideline. A specific calculation can be produced with consideration to all parameters.

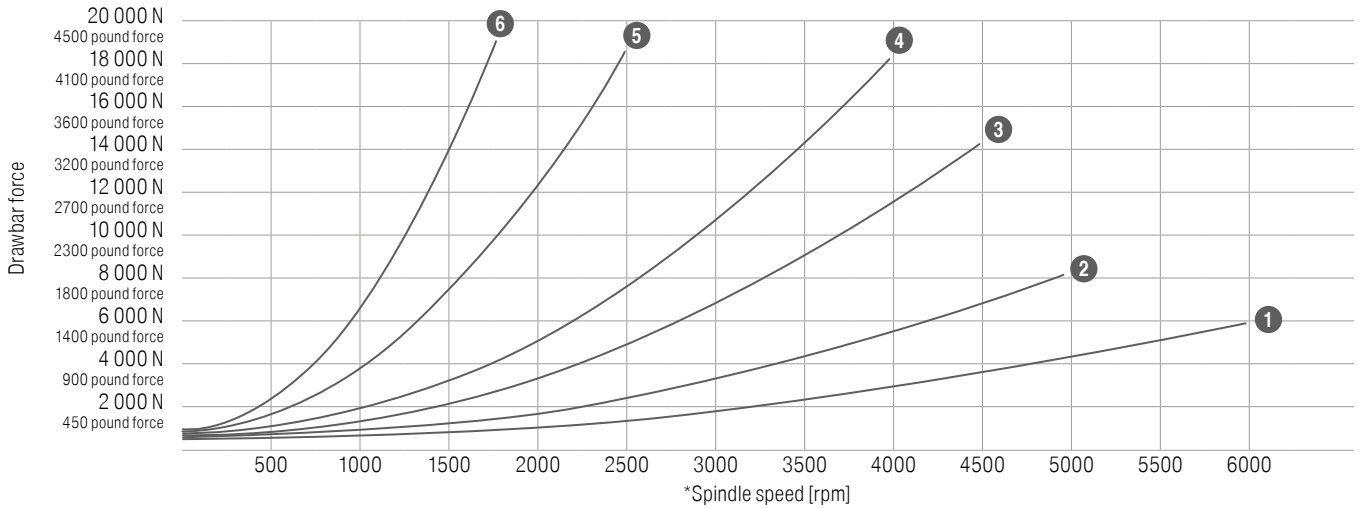

* Spindle speed [rpm]

Drawbar forces shown are valid for maximum weight of front tool.

max. weight of front tool

1	PKD 80	2× 0,2 kg	2× 0.4 lbs
2	PKD100	2× 0,3 kg	2× 0.7 lbs
3	PKD125	2× 0,45 kg	2× 1.0 lbs
4	PKD160	2× 0,6 kg	2× 1.3 lbs
5	PKD200	2× 0,8 kg	2× 1.8 lbs
6	PKD250	2×1,0 kg	2× 2.2 lbs

Lubrication requirements

Slide movement: 150 m / 6,000 in. (corresponds to one shift, 8 h)

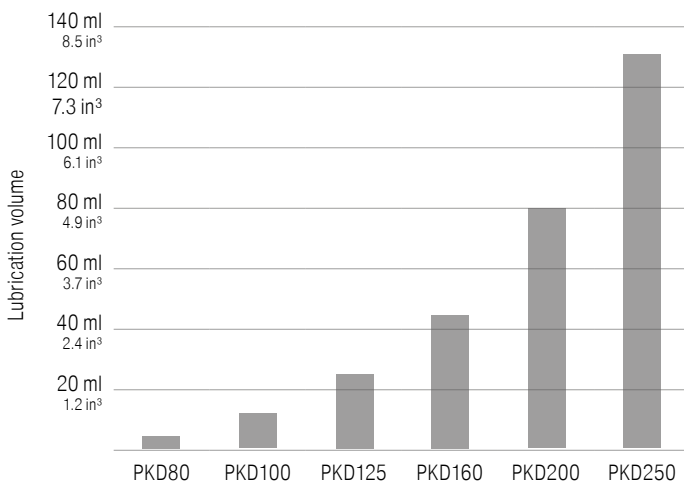

Lubrication volume required for one shift

The values specified are guide values and must, where required, be adjusted to the application conditions such as rotation speed, stroke and environmental influences such as coolant, dirt, etc.

Lubricants

We recommend Mobilux EP004 liquid grease for all speed ranges. Furthermore, it is also possible to use slideway oils according to DIN 51502 with the identifier CG-L68 or CG-L220 (CG-L220 is preferred for speeds from 700 rpm).

The relevant commercial names of the mineral oil companies for slide-way oils can be ascertained from the machine lubrication instructions. These lubrication instructions apply to all generating tools supplied by KOMET.

KOMdrive PKU-101

Facing head with counterweighted with mounting holes in slide

on request

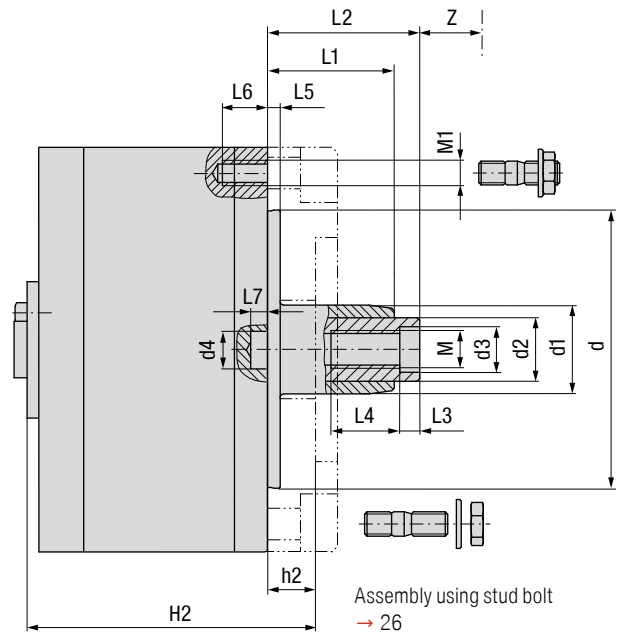
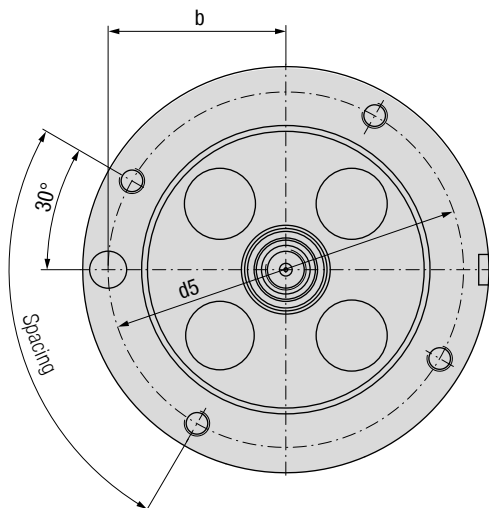
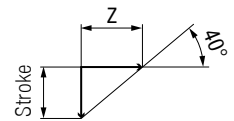
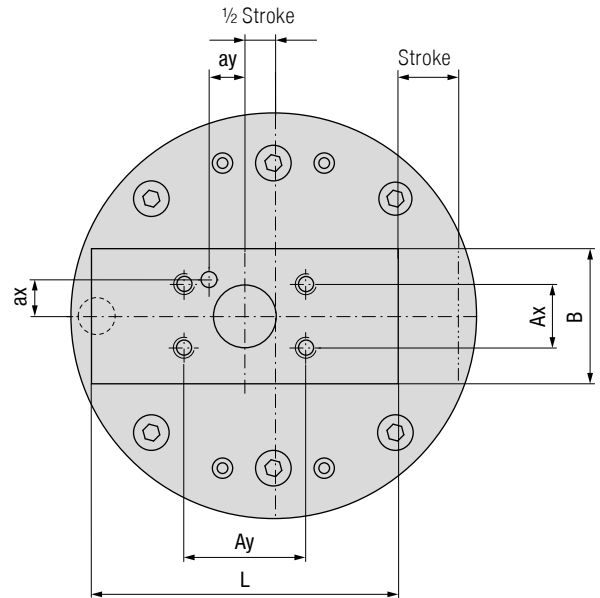
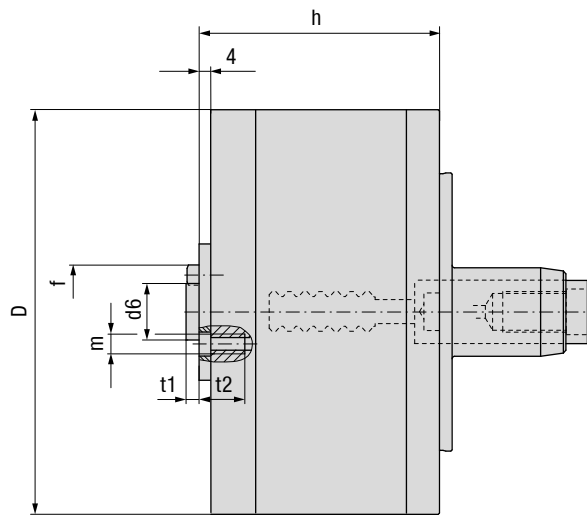
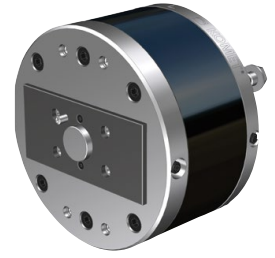

Assembly using stud bolt
→ 26
Adaptor flange for spindle
according to DIN 2079
→ 25

External dimensions										
Description	KOMET No.	D _{h6} mm	Stroke mm	Z mm	h mm	d _{h6} mm	d1 mm	d2 mm	d3 ^{H7} mm	d4 ^{+0,1} mm
PKU 100-10-101	P20 10110	100	10	11,9	66	65	25	16	12	10,3
PKU 125-6-101	P20 20010	125	6	7,2	73	90	30	20	14	14,6
PKU 125-15-101	P20 20110		15	17,9						
PKU 160-8-101	P20 30010	160	8	9,5	95	110	35	25	18	14,6
PKU 160-22-101	P20 30110		22	26,2						
PKU 200-10-101	P20 40010	200	10	11,9	115	150	44	32	18	16,2
PKU 200-30-101	P20 40110		30	35,7						
PKU 250-12-101	P20 50010	250	12	14,3	140	180	46	32	18	19,4
PKU 250-40-101	P20 50110		40	47,7						
PKU 320-15-101	P20 60010	320	15	17,9	174	220	63	40	22	24,2
PKU 320-50-101	P20 60110		50	59,6						

Slide dimensions												Front tool	
Size	B	L	Ax	Ay	ax±0,02	ay±0,02	d6 _{h6}	t1	t2	m	f _{m6}	kg	lbs
	mm	mm	mm	mm	mm	mm	mm	mm	mm	mm	mm	min - max	min - max
PKU 100-10-101	42	80	18	33	11	7	16	5	9	M6	5	0,22 - 0,4	0.5 - 0.9
PKU 125-6-101	52	88	28	50	14	15	20	5	16	M8	6	0,55 - 1,05	1.2 - 2.3
PKU 125-15-101	46	92	22	42	11	12	20	5	13	M6	5	0,53 - 0,9	1.2 - 2.0
PKU 160-8-101	66	106	32	60	16	18	25	5	19	M10	6	0,46 - 1,5	1.0 - 3.3
PKU 160-22-101	56	120	28	50	14	15	25	5	16	M8	6	0,47 - 1,2	1.0 - 2.6
PKU 200-10-101	78	130	40	80	20	25	30	5	18	M12	8	1,25 - 3,5	2.8 - 7.7
PKU 200-30-101	68	150	32	60	16	18	30	5	18	M10	6	1,15 - 2,7	2.5 - 6.0
PKU 250-12-101	93	156	50	90	25	30	32	5	18	M12	10	1,51 - 5,3	3.3 - 11.7
PKU 250-40-101	78	190	40	80	20	25	32	5	18	M12	8	1,23 - 3,8	2.7 - 6.0
PKU 320-15-101	108	194	60	120	30	40	40	5	28	M16	12	0 - 7,2	0 - 15.9
PKU 320-50-101	92	234	50	90	25	30	40	5	22	M12	10	0 - 5,4	0 - 11.9

Mounting dimensions															
Size	M	M1	L1	L2±1	L3	L4	L5	L6	L7	b±0,1	d5	Spacing	H2	h2	Spindle size
			mm	mm	mm	mm	mm	mm	mm	mm	mm		mm	mm	DIN 2079
PKU 100	M10×1L	M8	30	40	8	14	4	12	5	42	84	4×90° 3×120°	81	15	30
PKU 125	M12×1,5L	M8	37	47	8	16	4	12	6	54	110	6×60°	90	17	40
PKU 160	M16×1,5L	M10	50	60	10	25	5	15	6	70	140	4×90°	115	20	40
PKU 200	M16×1,5L	M12	70	80	10	25	5	18	6	87,5	175	4×90°	140	25	50
PKU 250	M16×1,5L	M16	90	100	10	25	6	22	6	108	216	4×90°	165	25	50
PKU 320	M20×1,5L	M16	106	116	10	30	6	22	8	137,5	275	6×60°	200	26	60

Order example:

Facing head Ø 250 mm / stroke 40 mm / type 101: Description PKU 250-40-101 / KOMET No. P20 50110

KOMdrive PKU-103

Facing head with counterweighted with integrated ABS-N connection

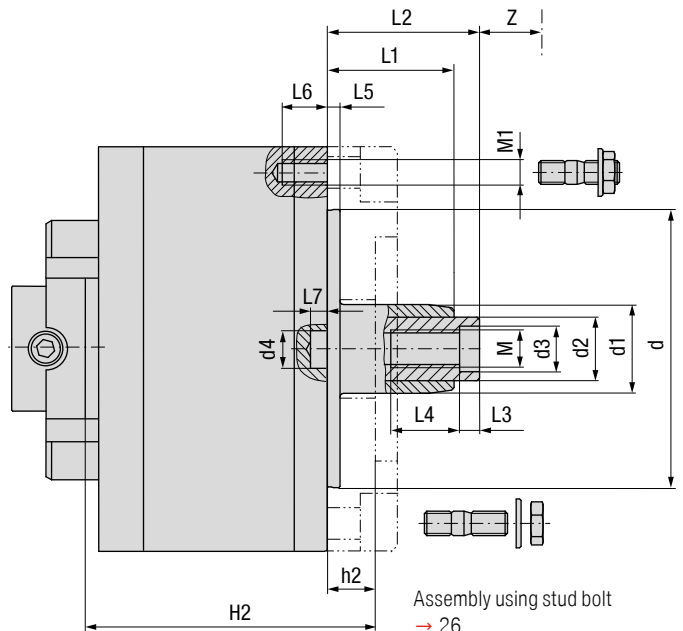
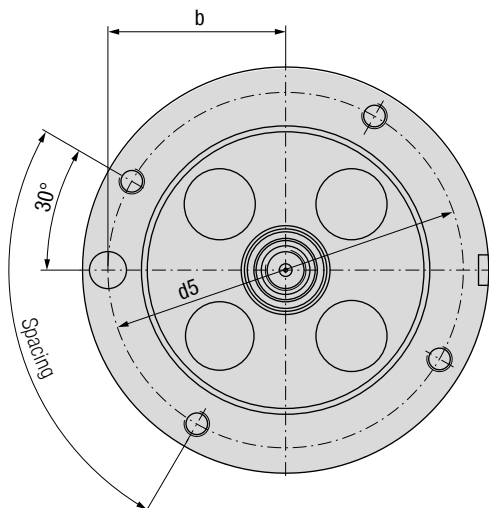
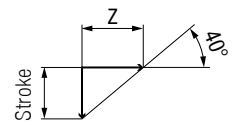
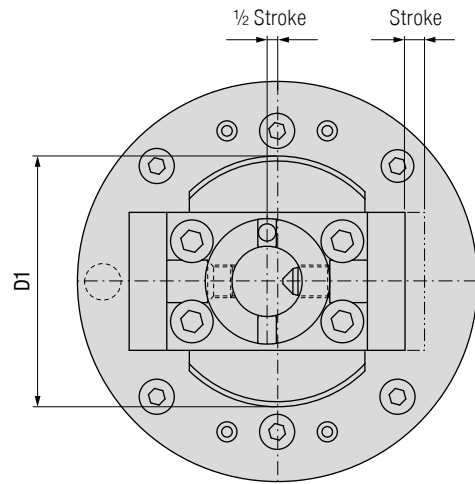
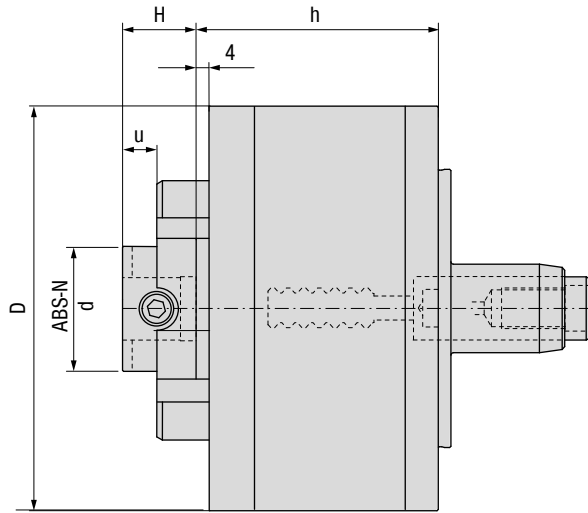

Assembly using stud bolt
→ 26
Adaptor flange for spindle
according to DIN 2079
→ 25

External dimensions											
Description	KOMET No.	D _{ns} mm	Stroke mm	Z mm	h mm	D1 mm	d _{ns} mm	d1 mm	d2 mm	d3 ^{H7} mm	d4 ^{+0.1} mm
PKU 100-10-103	P20 10130	100	10	11,9	61	64	65	25	16	12	10,3
PKU 125-6-103	P20 20030	125	6	7,2	73	85	90	30	20	14	14,6
PKU 125-15-103	P20 20130		15	17,9							
PKU 160-8-103	P20 30030	160	8	9,5	95	100	110	35	25	18	14,6
PKU 160-22-103	P20 30130		22	26,2							
PKU 200-10-103	P20 40030	200	10	11,9	115	125	150	44	32	18	16,2
PKU 200-30-103	P20 40130		30	35,7							
PKU 250-12-103	P20 50030	250	12	14,3	140	150	180	46	32	18	19,4
PKU 250-40-103	P20 50130		40	47,7							
PKU 320-15-103	P20 60030	320	15	17,9	174	180	220	63	40	22	24,2
PKU 320-50-103	P20 60130		50	59,6							

Slide dimensions				Front tool	
Size	d ABS-N	H mm	u mm	kg min - max	lbs min - max
PKU 100-10-103	32	24	20	0,09 - 0,29	0.2 - 0.6
PKU 125-6-103	40	25	12	0,2 - 0,8	0.4 - 1.8
PKU 125-15-103	32	20	10	0,34 - 0,8	0.7 - 1.8
PKU 160-8-103	50	30	14	0 - 1,0	0 - 2.2
PKU 160-22-103	40	25	12	0,21 - 0,9	0.5 - 2.0
PKU 200-10-103	63	35	16	0,32 - 2,5	0.7 - 5.5
PKU 200-30-103	50	30	14	0,7 - 2,2	1.5 - 4.9
PKU 250-12-103	80	40	20	0 - 3,7	0 - 8.2
PKU 250-40-103	63	35	16	0,27 - 2,9	0.6 - 6.4
PKU 320-15-103	100	55	30	0 - 4,17	0 - 9.2
PKU 320-50-103	80	40	20	0 - 3,9	0 - 8.6

Mounting dimensions															
Size	M	M1	L1 mm	L2±1 mm	L3 mm	L4 mm	L5 mm	L6 mm	L7 mm	b±0,1 mm	d5 mm	Spacing	H2 mm	h2 mm	Spindle size DIN 2079
PKU 100	M10×1L	M8	30	40	8	14	4	12	5	42	84	4×90° 3×120°	81	15	30
PKU 125	M12×1,5L	M8	37	47	8	16	4	12	6	54	110	6×60°	90	17	40
PKU 160	M16×1,5L	M10	50	60	10	25	5	15	6	70	140	4×90°	115	20	40
PKU 200	M16×1,5L	M12	70	80	10	25	5	18	6	87,5	175	4×90°	140	25	50
PKU 250	M16×1,5L	M16	90	100	10	25	6	22	6	108	216	4×90°	165	25	50
PKU 320	M20×1,5L	M16	106	116	10	30	6	22	8	137,5	275	6×60°	200	26	60

Order example:

Facing head Ø 250 mm / stroke 40 mm / type 103: Description PKU 250-40-103 / KOMET No. P20 50130

KOMdrive PKU-...

Technical notes

Drawbar force

stroke = start and end position

The diagram serves as a guideline. A specific calculation can be produced with consideration to all parameters.

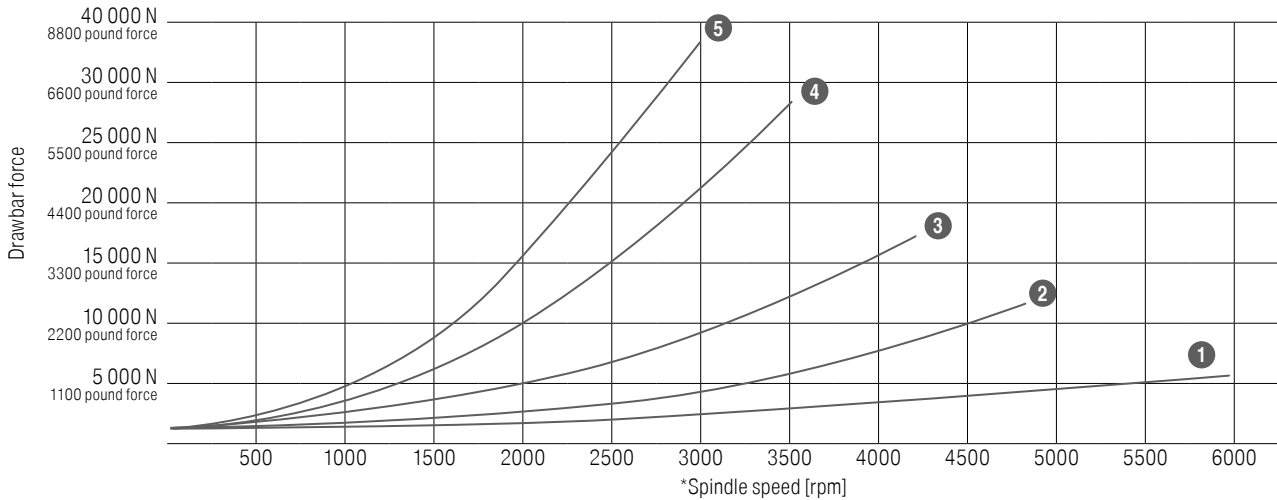

* Spindle speed [rpm]

Drawbar forces shown are valid for maximum weight of front tool.

max. weight of front tool

1	PKU 100	0,4 kg	0.9 lbs
2	PKU 125	0,6 kg	1.3 lbs
3	PKU 160	0,9 kg	2.0 lbs
4	PKU 200	2,0 kg	4.4 lbs
5	PKU 250	2,8 kg	6.17 lbs

Lubrication requirements

Slide movement: 150 m / 6,000 in. (corresponds to one shift, 8 h)

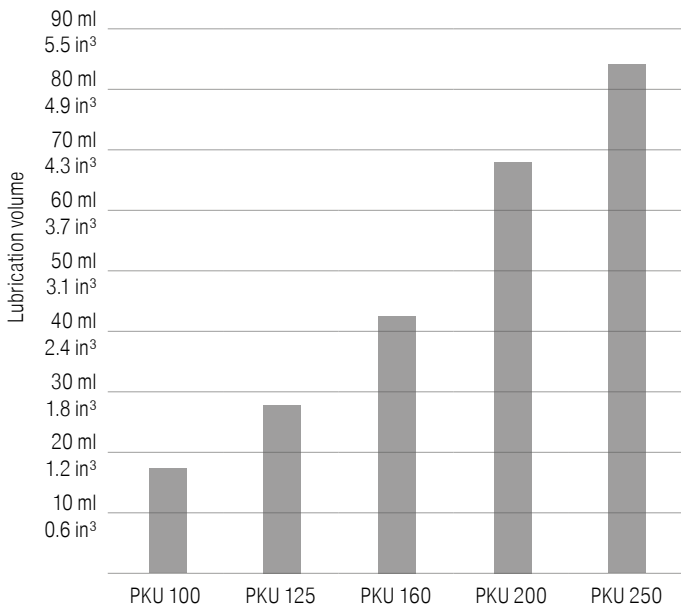

Lubrication volume required for one shift

The values specified are guide values and must, where required, be adjusted to the application conditions such as rotation speed, stroke and environmental influences such as coolant, dirt, etc.

Lubricants

We recommend Mobilux EP004 liquid grease for all speed ranges. Furthermore, it is also possible to use slideway oils according to DIN 51502 with the identifier CG-L68 or CG-L220 (CG-L220 is preferred for speeds from 700 rpm). The relevant commercial names of the mineral oil companies for slide-way oils can be ascertained from the machine lubrication instructions. These lubrication instructions apply to all generating tools supplied by KOMET.

KOMdrive PKE / PKD / PKU

Adaptor flange for spindle according to DIN 2079

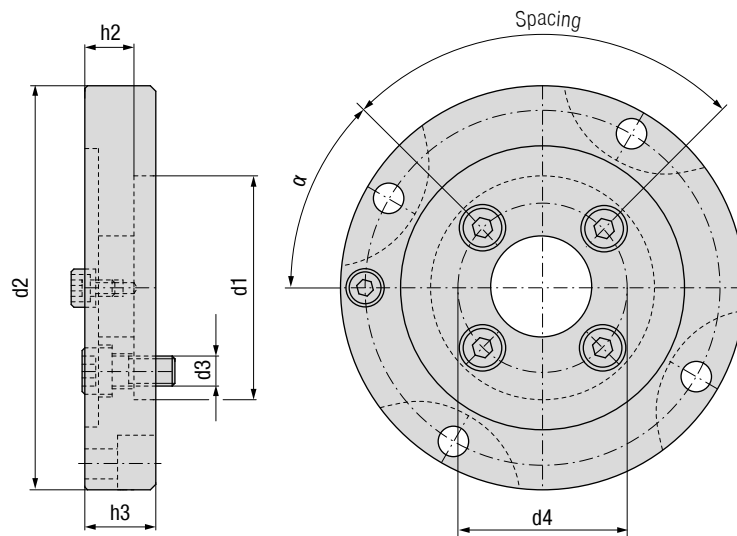

Mounting dimensions, spindle

Size	KOMET No.	d1 ^{H6} mm	d2 mm	h3 mm	h2 mm	α	d3 mm	d4±0,2 mm	Spacing	Spindle size DIN 2079
... 80-...	P00 00300	69,832	80	26	18	15°	10	54	4×90°	30
... 100-...	P00 10300	69,832	100	23	15	15°	10	54	4×90°	30
... 125-...	P00 20400	88,882	125	25	17	45°	12	66,7	4×90°	40
... 160-...	P00 30400	88,882	160	28	20	45°	12	66,7	4×90°	40
... 200-...	P00 40500	128,57	200	35	25	45°	16	101,6	4×90°	50
... 250-...	P00 50500	128,57	250	35	25	45°	16	101,6	4×90°	50
... 320-...	P00 60600	221,44	320	41	26	45°	20	177,8	4×90°	60

Assembly variants

Assembly using stud bolt per DIN 939

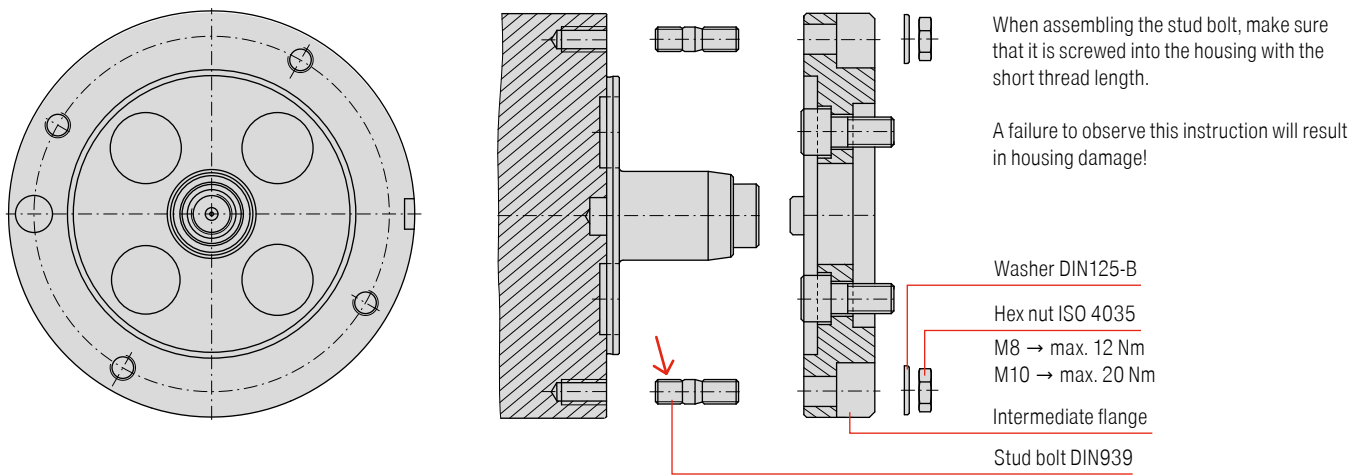

Assembly using threaded insert/stud bolt with PKE 160...101-QA-IK-F

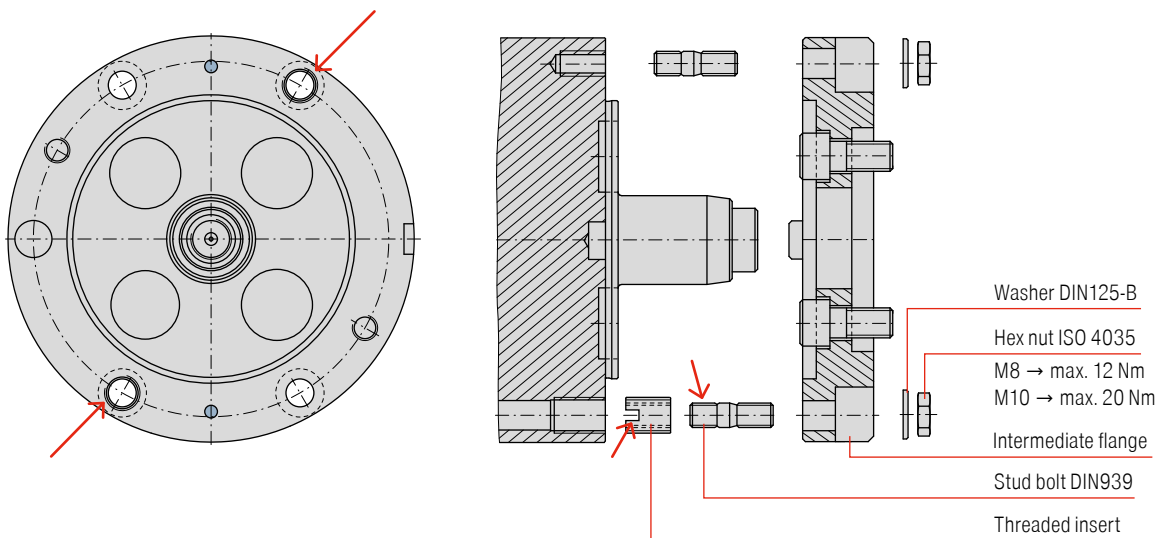

When assembling the stud bolt provided, it is necessary to install threaded inserts in two holes. The threads are adapted to the correct size through usage of the threaded inserts provided.

Threaded insert assembly:

Observe direction (position of the slot). Screw in the threaded insert until slightly recessed or flush in accordance with the assembly instructions, and secure with medium-tight screw lock.

Use the specified tools or other suitable auxiliary aids to screw in the threaded inserts.

Stud bolt assembly:

When assembling the stud bolt, make sure that it is screwed into the threaded insert with the short thread length.

A failure to observe this instruction will result in housing damage!

Assembly variants

Assembly using cylinder head screws per ISO 4762

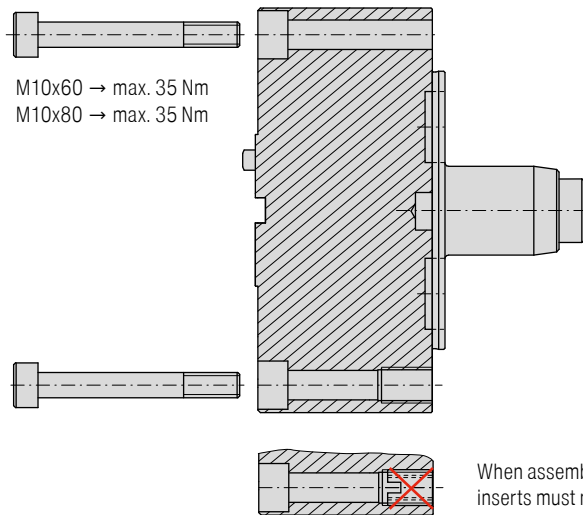

Auxiliary aids for assembly/removal of the threaded insert

Screw in using hand tool:

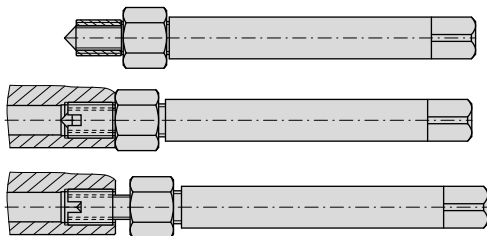

Screwing in by hand usually takes place with the hand tool via the internal thread of the threaded insert:

Screw on the threaded sleeve, note the slot position! Make sure that the screw does not point into the cutting edge geometry after locking with the nut.

Screw in the threaded insert up to approx. 0.1-0.2 mm below the tool surface (in case of makeshift assembly using screw and nut, screw in the threaded insert until flush as a minimum). Ensure vertical assembly.

Makeshift screwing in with screw/nut:

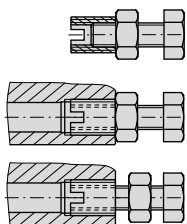

Counter-lock the nut, otherwise the threaded insert will be unscrewed again.

Then unscrew the hand tool or screw/nut.

Workpiece: hydraulic block

Machining with rotary-driven slide boring bar

The modular slide boring bar is rotary-driven by the machine spindle, supported by the counter bearing. The boring bar is used in hydraulic block manufacturing and machines the transition from the main bore to the cross bore.

The slide stroke is 18 mm with an external diameter of 50 mm.

The indexable insert holders can be replaced after each machining task (semi, finish). The modular structure means that the boring bar can be flexibly extended using an adapter. The boring bar has a length of 458 mm without an adapter (HSK100 collar up to cutting edge) and 790 mm with an adapter.

Functional sequence:

- ▲ Insertion when stationary and counter-bearing positioned
- ▲ Retraction to the middle of the cross bore
- ▲ Spindle set to machining speed
- ▲ Transition removed (forwards and back)
- ▲ Boring bar moved to middle of cross bore
- ▲ Spindle stopped
- ▲ When stationary, removed from bore
- ▲ The counter bearing is pulled out of the bearing hole

Cutting data:

$n = 260 \text{ min}^{-1}$	$f = 0,20 \text{ mm/rev}$
$v_c = 116 - 130 \text{ m/min}$	$f_z = 0,10 \text{ mm/rev}$
$v_f = 52 \text{ mm/min}$	

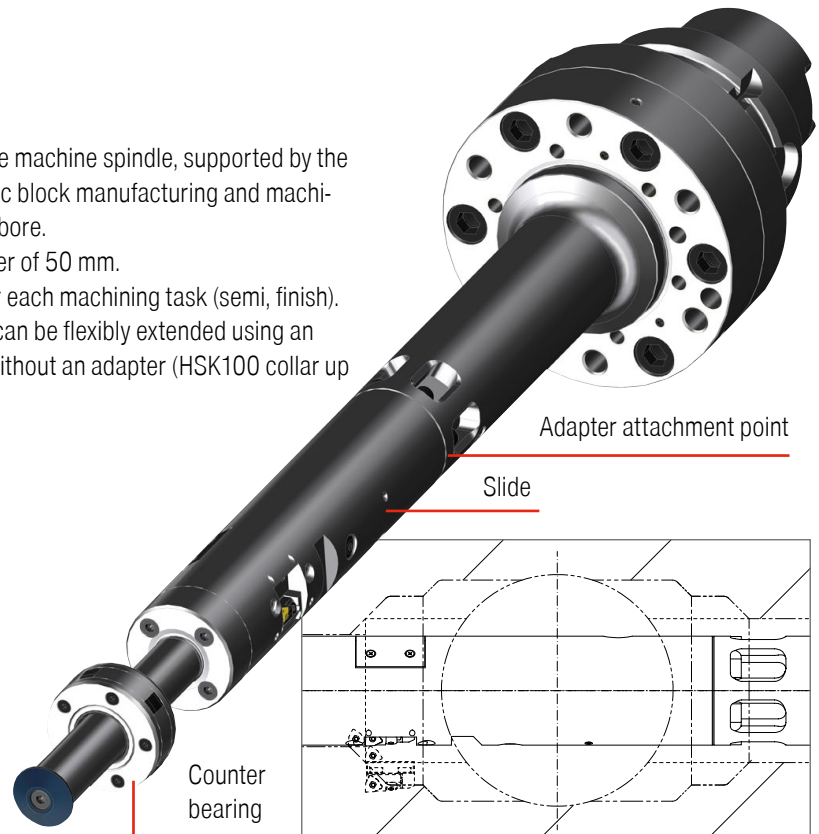

Workpiece: gear case

Machining:

- ▲ finishbore bearing $\text{Ø } 80^{\text{H7}} / \text{Ø } 100^{\text{H7}}$
($\text{Ø } 3.149'' + 0.00125''$ and $\text{Ø } 3.937'' + 0.0014''$)
with bridge mounted tools
- ▲ retract after boring
- ▲ face turn with slide

Cutting data:

$\text{Ø } 80 / 100 \text{ mm}$	$\text{Ø } 3.149'' / 3.937''$
$v_c = 400 \text{ m/min}$	1,300 sfm
$n = 1591 \text{ min}^{-1}$	1,591 rpm
$f = 0,11 \text{ mm/rev}$	0.0044 ipr
$v_f = 175 \text{ mm/min}$	6.89 ipm

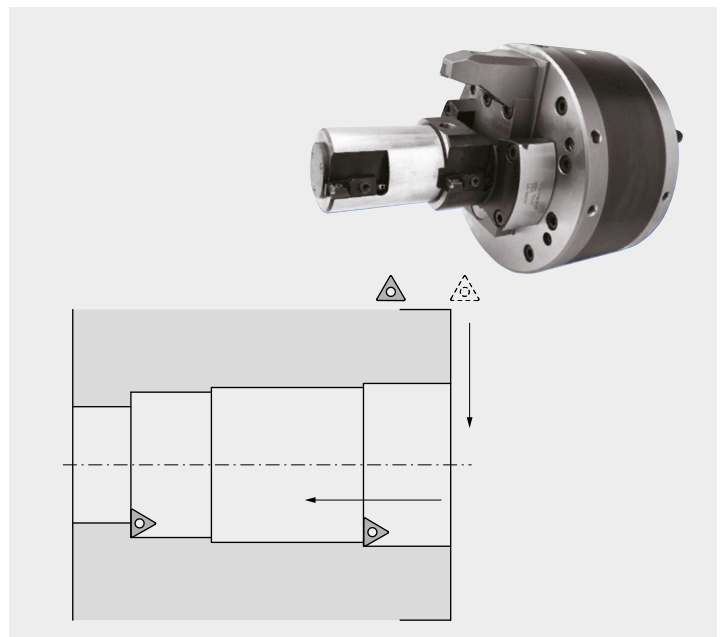

Workpiece: engine block

Machining: Cylinder bore in engine blocks / coolant-precision drilling system

The tool is loaded with 40 bar (ICS), the cutting edges extend. The pressure is increased on the bottom of the hole, the cutting edges retract.

The tool can be moved out of the fitted position in rapid mode G0 with no contour distortion.

The cutting edge adjustment is performed via the machine control system/spindle.

Material 3.3206 (AlSi7MgCu0,5)

Cutting data:

$v_c = 500$ m/min	$n = 1887$ min ⁻¹
$v_f = 1415$ mm/min	$f = 0,75$ mm/rev
$a_p = 0,35$ mm im Radius	Surface $R_z 25,8$

- ▲ Central cutting edge adjustment
- ▲ Lifting of the cutting edge above ICS 40 bar



Workpiece: gear case

Machining:

- ▲ bore $\varnothing 25/220/227$ mm ($\varnothing 0.984"/8.661"/8.937"$) and turn $\varnothing 46$ mm ($\varnothing 1.811"$) with fixed tools
- ▲ operate slide to face turn $\varnothing 226 / 206$ mm ($\varnothing 8.897"/8.110"$)
- ▲ face turn $\varnothing 220$ mm ($\varnothing 8.661"$) and $\varnothing 46$ mm ($\varnothing 1.811"$)
- ▲ groove bottom of gear case with grooving insert

Cutting data:

$\varnothing 25 - 227$ mm	$\varnothing 0.984"$ to $\varnothing 8.937"$
$v_c = 161 - 1450$ m/min	500 - 4800 sfm
$n = 2000$ min ⁻¹	2,000 rpm
$f = 0,1$ mm/rev	0.004 ipr
$v_f = 200$ mm/min	7.87 ipm

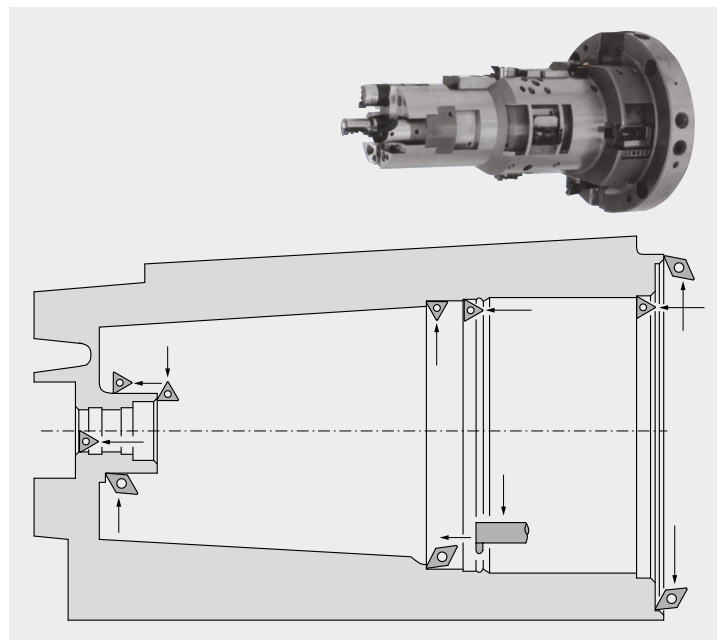

Workpiece: Tube end machining

Machining:

- ▲ chamfer bore
- ▲ bore inner contour including undercut
- ▲ chamfer outer diameter and plungecut the face
- ▲ cut thread in multiple passes
- ▲ centrally located front tool is exchangeable for machining different tube diameters

Cutting data:

Ø 94 mm	Ø 3.700"
$v_c = 220$ m/min	725 sfm
$n = 1350$ min ⁻¹	1,350 rpm
$f = 0,12$ mm/rev	1,35053 ipr
$v_f = 162$ mm/min	6.75 ipm

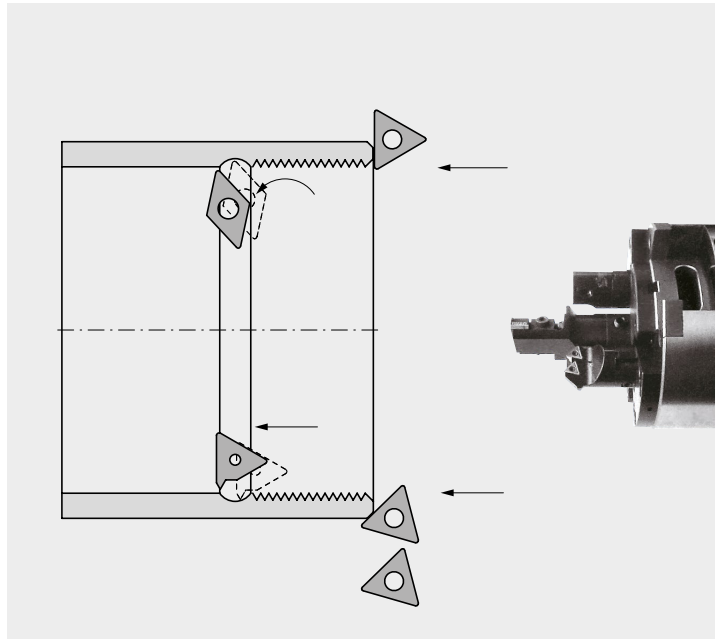

Workpiece: bearing housing

Machining:

- ▲ bore Ø 40 mm (Ø 1.575") and chamfer 1×45°;
Turn outer Ø 95 mm (Ø 3.740") and step Ø 86 mm (Ø 3.386")
- ▲ lift of cutting edges
- ▲ turn both faces

Cutting data:

Ø 50 mm / 1.575"	Ø ₂ 110 mm / 2 4.331"
$v_c = 180$ m/min	600 sfm
$n_1 = 1150$ min ⁻¹	1,550 rpm
$n_2 = 520$ min ⁻¹	520 rpm
$f = 0,15$ mm/rev	0.006 ipr
$v_{f1} = 172$ mm/min	6.77 ipm
$v_{f2} = 80$ mm/min	3.15 ipm

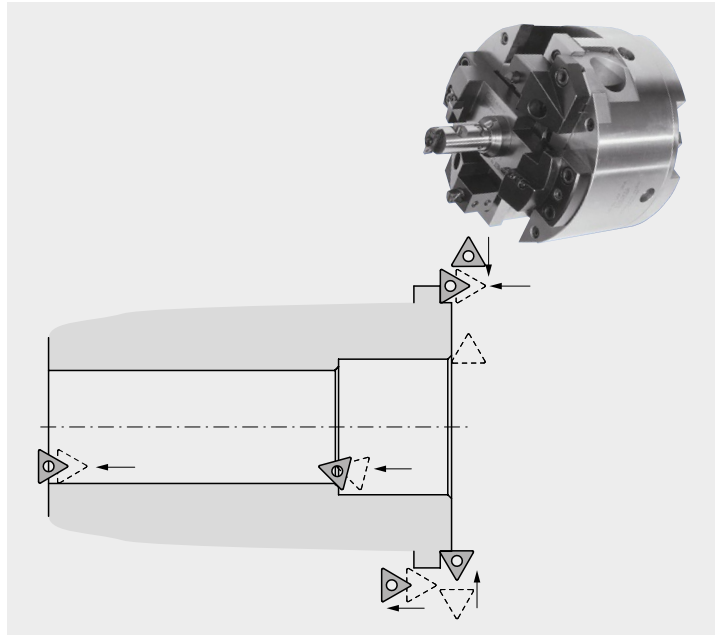

Workpiece: cylinder head / valve seat

Machining:

- ▲ generate 120° outer relief angle through coordinated axial movement of the machine spindle and drawbar
- ▲ machine valve sealface 90°-30' through drawbar actuation
- ▲ generate 60° inner relief angle
- ▲ ream valve guide bushing

Cutting data:

Ø 38,6 - 23 mm	Ø 1.520" to 0.906"
$v_c = 242 - 144$ m/min	800 - 475 sfm
$n = 2000$ min ⁻¹	2,000 rpm
$f = 0,08$ mm/rev	0.003 ipr
$v_f = 160$ mm/min	6.30 ipm

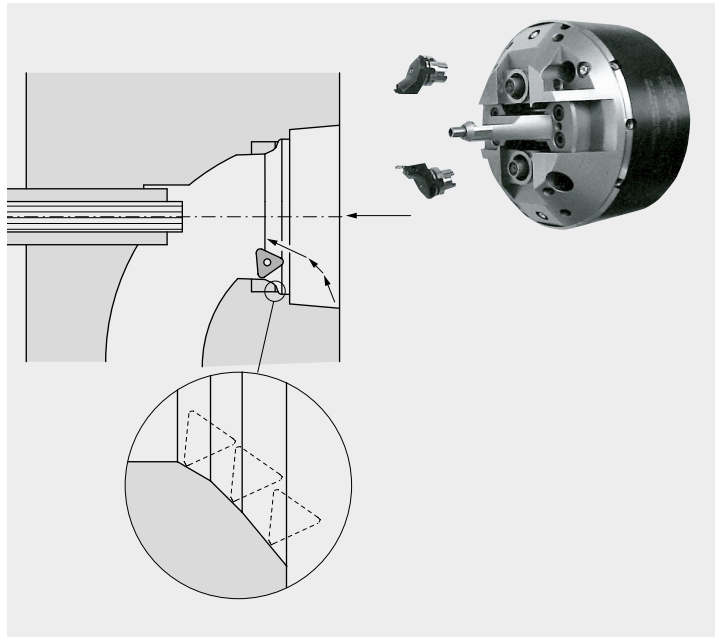

Workpiece: shaft machining

Machining:

Turn contour with double slide generating heading furnished with central throughbore (also available with rotating center support)

Cutting data:

Ø 37 - 12 mm	Ø 1.457" to Ø 0.472"
$v_c = 260 - 34$ m/min	850 sfm
$n = 2240$ min ⁻¹	2,240 rpm
$f = 0,1$ mm/rev	0.004 ipr
$v_f = 224$ mm/min	8.82 ipm

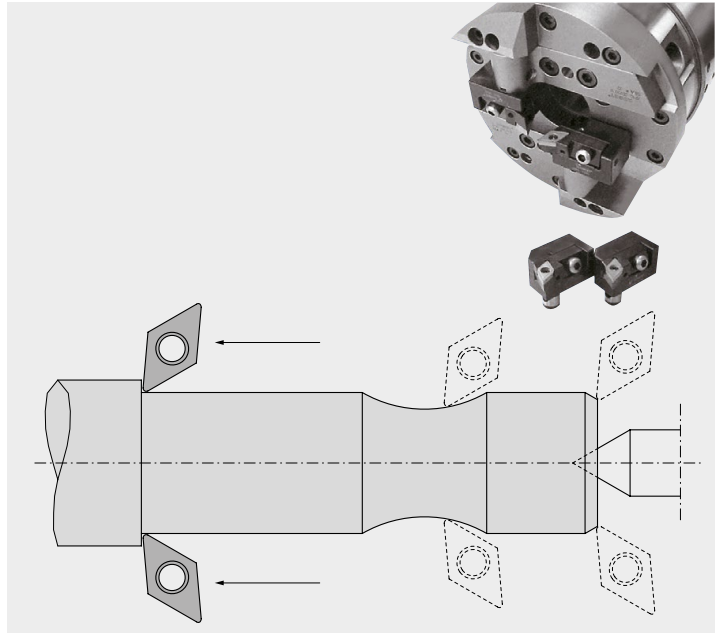

Modified facing heads

Modification 1

Rack angle for various transmission ratios. All facing heads are also available with transmission ratios of 1:1 and 1:2.

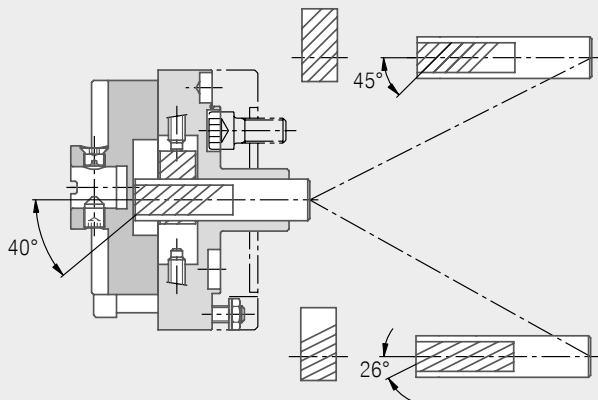

Modification 2

Drawbar connection with different locating diameter and thread. Capable to connect with existing machines.

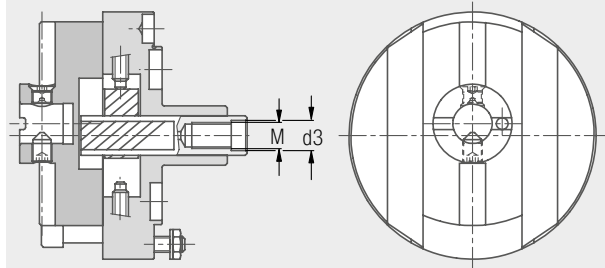

Modification 3

Additional mounting holes to install bridge. Installation of fixed tools to combine boring and facing operations.

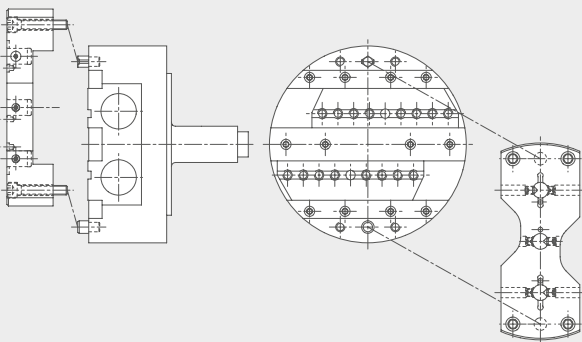

Modification 4

Modified mounting hole pattern in slides allows the installation of existing cutting tools.

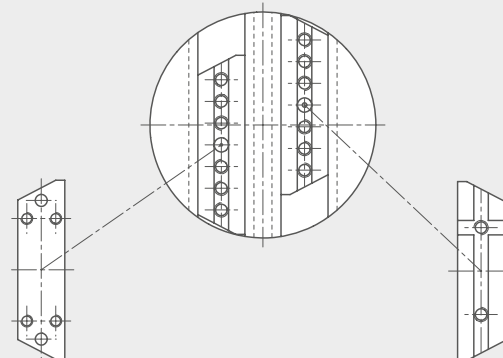

Modification 5

Coolant supply through the face of the spindle. Improved chip control and chip removal in drilling and boring operations.

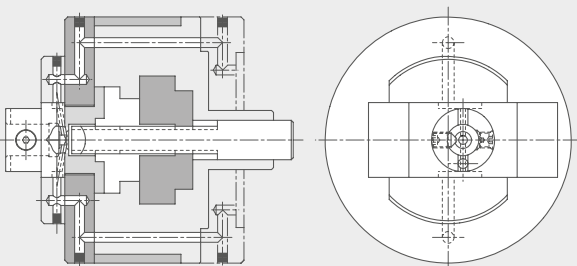

Below is a listing of modifications to standard facing heads which are available upon request. Replacement parts such as drawbars, gear racks and slides are stocked as semifinished components.

KOMtronic SMS / UAC / UAD

Facing heads with integrated measuring system and KOMtronic U-axis systems for spindle integration

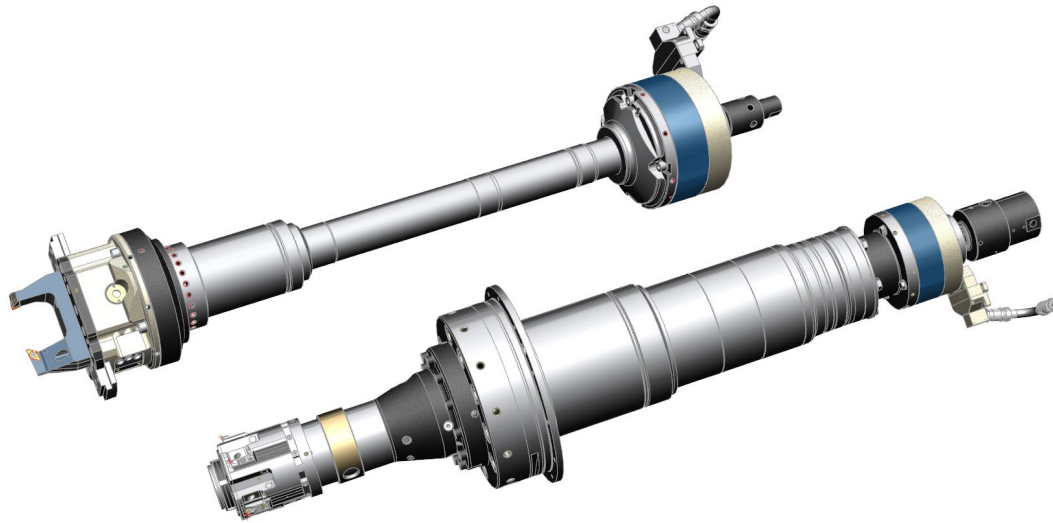

Produce turning contours economically when working with a stationary workpiece

Based on decades of experience producing facing heads for special purpose machines, CERATIZIT is expanding its product range to include KOMtronic systems for spindle integration for different installation and usage requirements for facing heads.

- ▲ Facing heads with direct encoder on the slide
- ▲ KOMtronic systems for spindle integration with own drive

KOMlife

Autonomous acquisition of production data accurate to the second



KOMET

Autonomous acquisition and processing of production data directly on the respective tool

Advantages Benefits

- ▲ **Planned, preventative maintenance**
Regular, advance maintenance planning can increase tool service life and ensure workpiece quality at all times.
- ▲ **Digital production data acquisition**
Through a patented, dynamic QR code and the KOMlife app.
- ▲ **Assessment of tool use**
Conclusions can be drawn about the status and load of the cutting edge by gathering data on tool use.
- ▲ **Not dependent on tool manufacturer**
KOMlife can be easily integrated into new and existing linear and rotating systems, irrespective of the tool manufacturer.

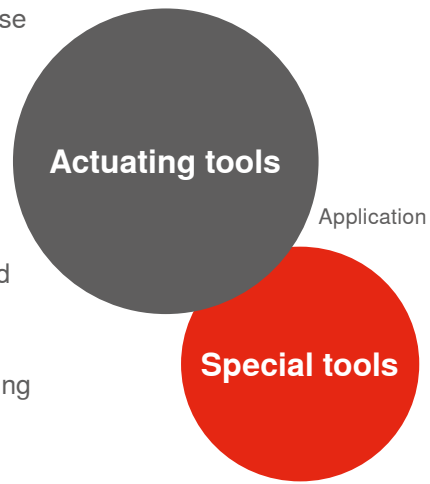

Technical data	
Lithium battery	CR2032
Battery life	Approx. 2 years
Min. acceleration	1,5 g
Min. tool diameter	50 mm



cuttingtools.ceratizit.com/gb/en/komlife



Ergonomic display unit

- ▲ Number of operating hours
- ▲ Current status of the maintenance interval
- ▲ Dimensions: 30 x 30 x 11 mm

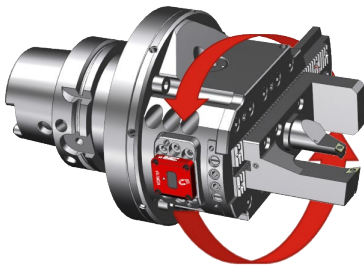

Tool rotates

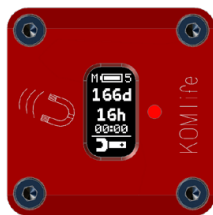
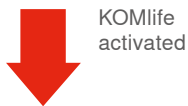

Customer-specific adaptation

- ▲ Adjustable maintenance interval depending on the application
- ▲ Visualisation of the necessary tool maintenance with a red, flashing LED

Maintenance interval reached



Digital display of production data

Patented, dynamic QR code

- ▲ Digital acquisition and export of production data via smartphone and KOMlife app
- ▲ Display of serial number and production data



Try me out with the KOMlife app!

Free KOMlife app in the App Store for iOS devices



ENGINEERS FIRST AND FOREMOST.

**JUST
OUR
THING**



**TECHNICAL SUPPORT.
WHEN YOU NEED IT MOST.**

**OUR WAREHOUSE IN YOUR
MACHINE SHOP.**

www.just-our-thing.com



THE Cutting Tool Solution

CERATIZIT UK & IRELAND LTD
Europa Link \ UK-Sheffield S9 1XU
Tel.: +44 114 242 8 820
info.uk@ceratizit.com \ www.ceratizit.com



Part of the Plansee Group