

## Multitask machines

### Demands for maximum versatility from tool manufacturers

- ▲ Flexible standard range for different machining processes
- ▲ Powerful tools designed for multitask machining
- ▲ Customised special solutions

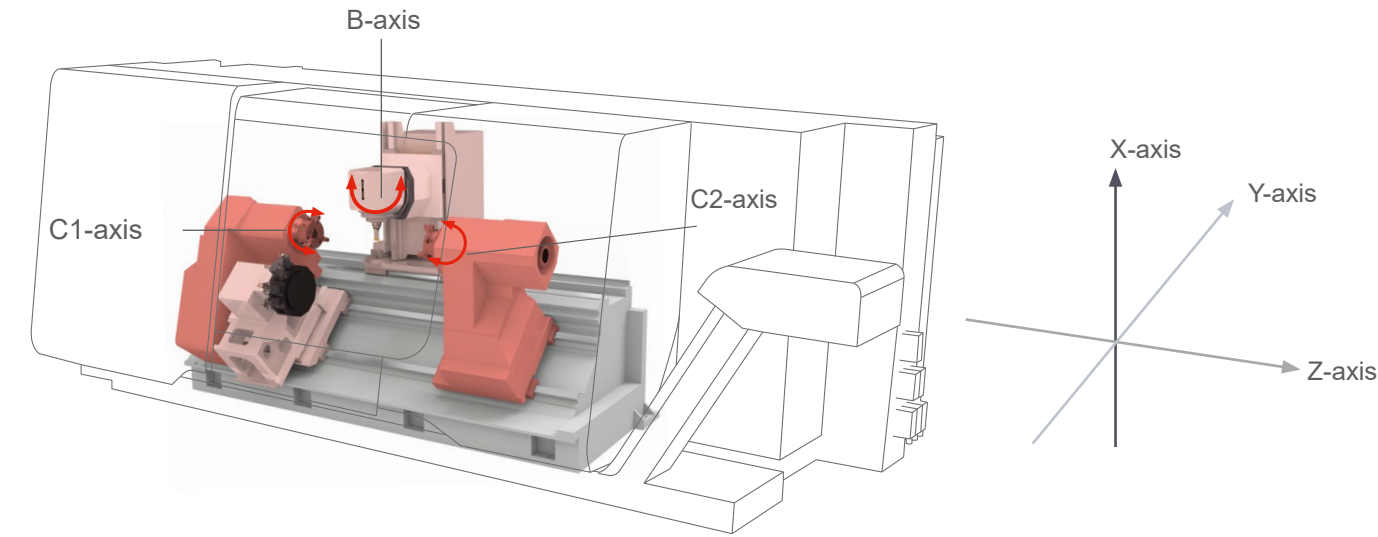

### Application examples

	Milling spindle				Turret		
	X-axis	Z-axis	Y-axis	B-axis	X-axis	Z-axis	Y-axis
Grooving and parting off	✓		✓		✓		✓
External turning	✓	✓	✓	✓	✓	✓	✓
Face turning	✓	✓	✓	✓	✓	✓	✓
Internal turning	✓	✓	✓	✓	✓	✓	✓
Internal diameter drilling		✓		✓		✓	
Tapping	✓	✓	✓	✓	✓	✓	✓
Face thread cutting	✓	✓	✓	✓	✓	✓	✓
Screw cutting	✓	✓	✓	✓	✓	✓	✓
External diameter drilling	✓	✓		✓			
External diameter milling	✓	✓		✓			
Main spindle milling/bore machining	✓	✓		✓			
Counter spindle milling/bore machining	✓	✓		✓			



ENGINEERS FIRST AND FOREMOST.

JUST  
OUR  
THING

TECHNICAL SUPPORT.  
WHEN YOU NEED IT MOST.

OUR WAREHOUSE IN YOUR  
MACHINE SHOP.

[www.just-our-thing.com](http://www.just-our-thing.com)



THE Cutting Tool Solution

CERATIZIT UK & IRELAND LTD  
Europa Link \ UK-Sheffield S9 1XU  
Tel.: +44 114 242 8 820  
info.uk@ceratizit.com \ www.ceratizit.com



Multitask  
machining

Powerful tool portfolio with great  
flexibility for machining complex components

CERATIZIT is a high-technology engineering  
group specialised in cutting tools and hard  
material solutions.

Tooling a Sustainable Future

[ceratizit.com](http://ceratizit.com)



07/2023 - 98.022.00755



# Multitask machining

## Tool holders with DirectCooling (DC)

Targeted coolant application on the cutting edge

- ▲ The DirectCooling (DC) range offers accurate and targeted cooling rather than flood lubrication of the general area.
- ▲ For longer service lives and higher performance from the cutting edges.

### Advantages/benefits

The lengths of all CERATIZIT DirectCooling holders are perfectly matched to one another. As a result...

- ▲ Interference contours are eliminated
- ▲ A compact complete package is created
- ▲ Optimum stability is reached
- ▲ Unlimited flexibility is achieved

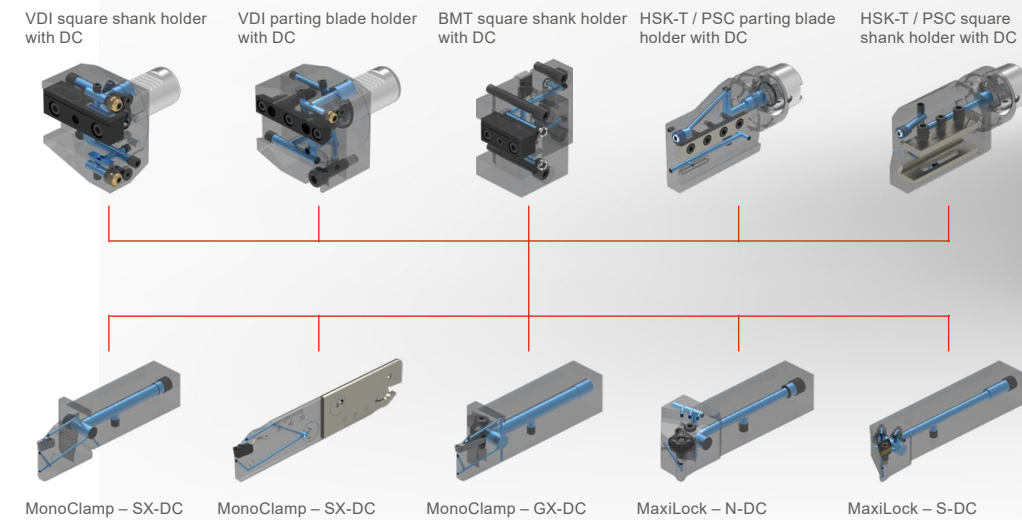

Adapter

Holder

Find out more here

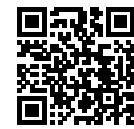

[cutting.tools/gb/en/multitask](http://cutting.tools/gb/en/multitask)

## Drilling and turning with the EcoCut multifunctional tool

Reduces setup times and boosts your productivity



[cuttingtools.ceratizit.com/gb/en/ecocut](http://cuttingtools.ceratizit.com/gb/en/ecocut)

## High Dynamic Turning with FreeTurn

Roughing, finishing, contour turning, facing and longitudinal turning, all with just one tool



[cutting.tools/gb/en/freeturn](http://cutting.tools/gb/en/freeturn)

## Different boring bar base holders in combination with exchangeable cutting heads

The modular cutting head system for turning is also compatible with vibration-damped boring bars.

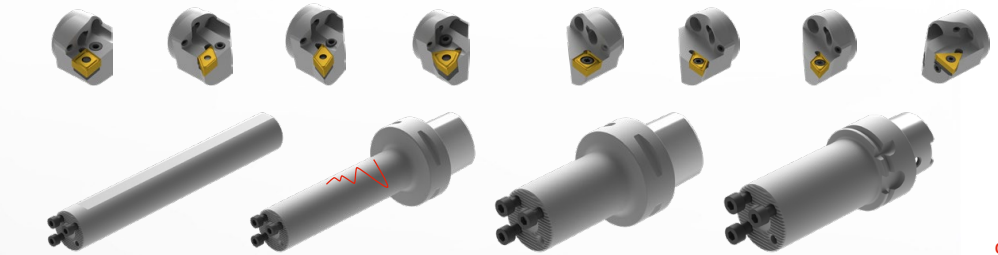

[cutting.tools/gb/en/boring-bar](http://cutting.tools/gb/en/boring-bar)

## Turning tool holder with machine interface

Choose the turning tool holders in different sizes and versions to fit your machine interface.

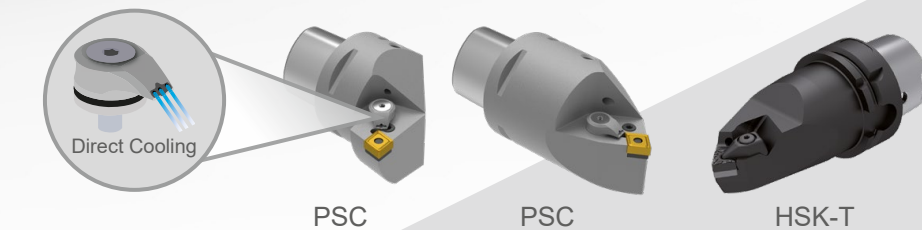

Mono turning tool holders are compact and offer a combination of precision, ease of handling and flexibility that makes them such a good choice for the turning of workpieces.

### Advantages/benefits

- ▲ High basic stability
- ▲ For efficient turning
- ▲ High precision
- ▲ Easy handling
- ▲ Low space requirement
- ▲ Simple tool change



[cutting.tools/gb/en/stationary-adapters](http://cutting.tools/gb/en/stationary-adapters)

## The right indexable insert for the widest range of applications

Find the right turning, drilling and grooving inserts for your machining scenario

The exact cutting insert to be used depends on the production method as well as the type and hardness of the material to be machined. To achieve good chip control and the best results, it is important that the geometry, grade, shape, size, corner radius and setting angle of the indexable insert is carefully selected.



[cutting.tools/gb/en/turning](http://cutting.tools/gb/en/turning)



[cutting.tools/gb/en/directcooling](http://cutting.tools/gb/en/directcooling)

Direct  
DC  
Cooling

- ▲ Fewer trapped chips
- ▲ Reduced wear
- ▲ Universal application