

SELECTION

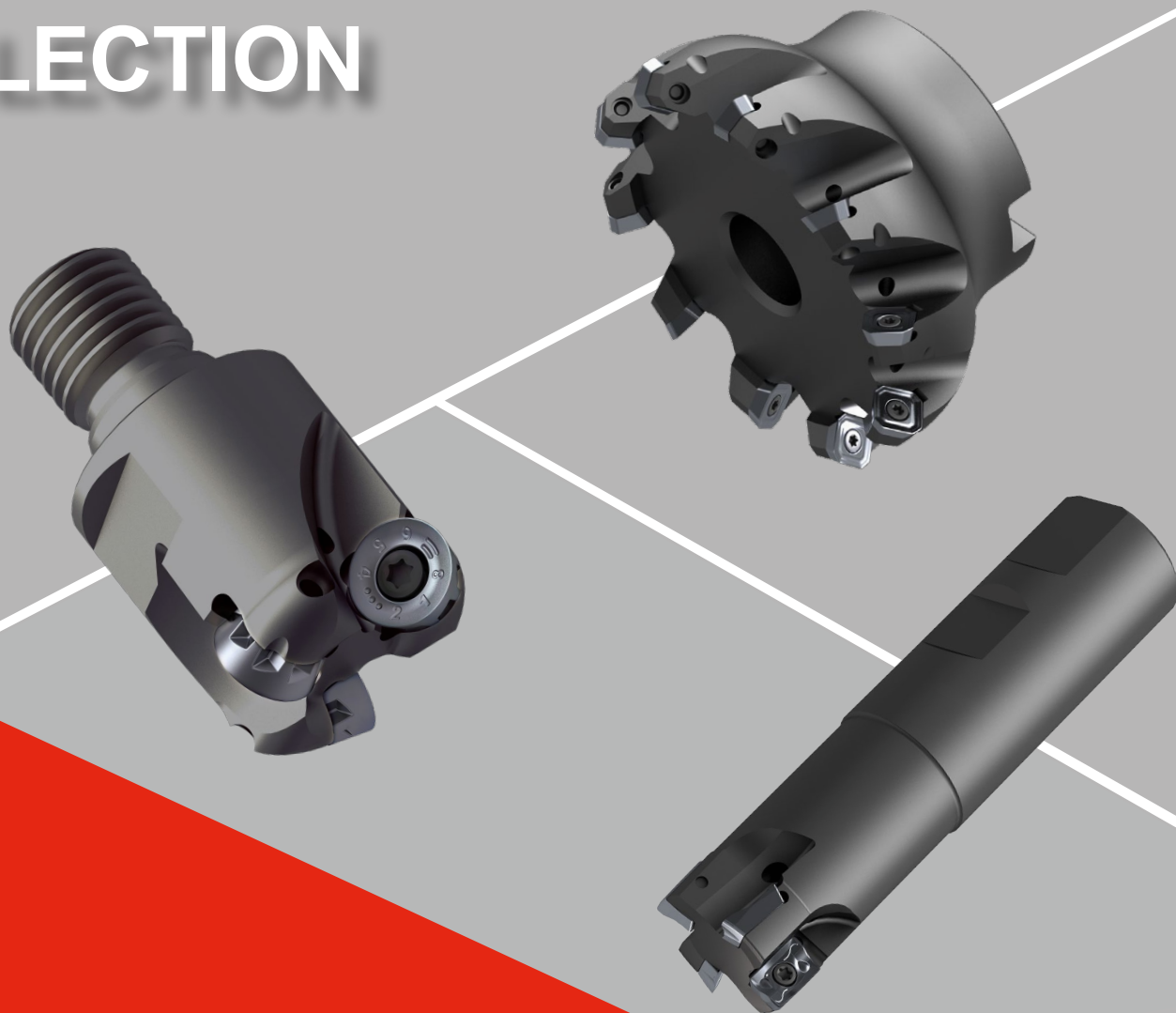

Narzędzia do frezowania z płytkami wymiennymi do zastosowań ogólnych z serii CERATIZIT CoreLine

CERATIZIT to grupa zaawansowanych technologicznie przedsiębiorstw, specjalizujących się w narzędziach do obróbki skrawaniem oraz rozwiązaniach z zakresu materiałów twardych.

Tooling a Sustainable Future

ceratizit.com



CERATIZIT
GROUP

Spis treści

Objaśnienie symboli	2
Toolfinder	3
Program produktów	4–10
Informacje techniczne	
Parametry skrawania	12
Opis gatunków	12
Parametry zastosowania – frezowanie płaszczyzn	13
Parametry zastosowania – frezowanie kątów	14
Parametry zastosowania – frezowanie kształtowe	15

Objaśnienie symboli

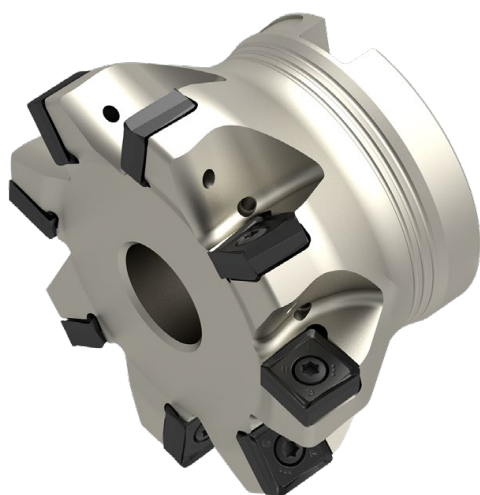
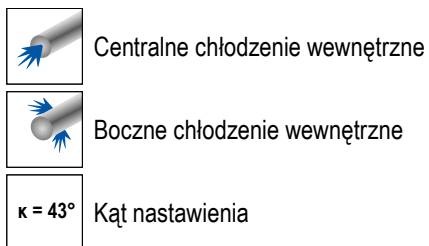





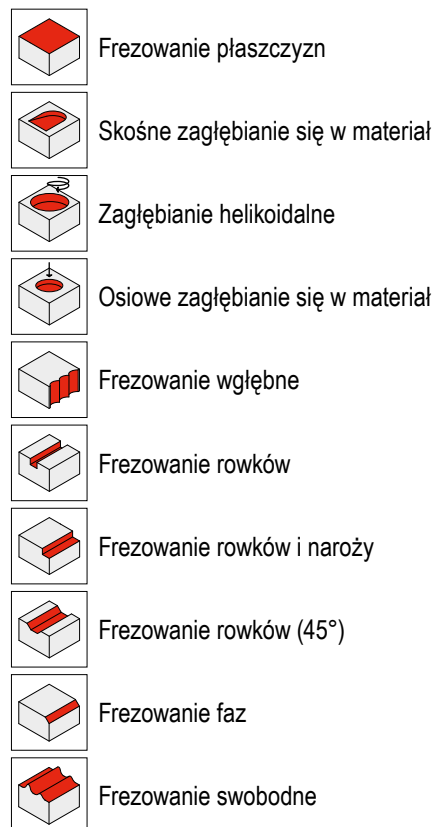

- ZNF = Ilość zębów
- = Zastosowanie podstawowe
 - = Zastosowanie dodatkowe

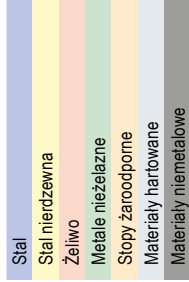
Symbole obszaru zastosowania

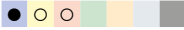

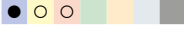
Przegląd

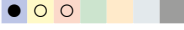
System	Płytki	Liczba ostrzy przypadająca na płytkę wymienną	$a_{p,max}$ mm	Zakres \varnothing mm		Strona	
Frezowanie płaszczyzn							
CoreLine 270	SDNT 09..	4	4	 \varnothing 40-100		4	
Frezowanie rowków i naroży							
CoreLine 210	APKT 1003..	4	7	 \varnothing 20-32	 \varnothing 40-80		5+6
Frezowanie kształtowe							
CoreLine 251	RPNX 10T3..	8	4,5	 \varnothing 15-22	 \varnothing 30-40		7+8

CoreLine – Frez nasadzany – 270-09

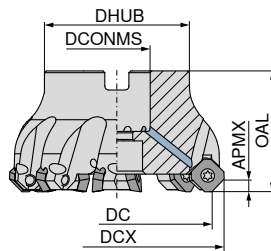
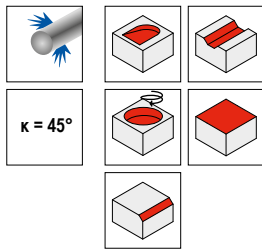

51 702 ...

Oznaczenie	DC mm	DCX mm	ZNF	APMX mm	OAL mm	DHUB mm	DCONMS _{H6} mm	moment dociagowy Nm	Płytki wymienna
A270.40.R.03-09.N	40	48,4	3	4	40	38	16	1,2	SD.. 0903..
A270.50.R.05-09.N	50	58,4	5	4	40	43	22	1,2	SD.. 0903..
A270.63.R.06-09.N	63	71,4	6	4	40	48	22	1,2	SD.. 0903..
A270.80.R.07-09.N	80	88,4	7	4	50	58	27	1,2	SD.. 0903..
A270.100.R.08-09.N	100	108,4	8	4	50	78	32	1,2	SD.. 0903..

EUR	CX
186,00	04003
237,90	05005
294,30	06306
344,40	08007
442,10	10008

SDNT

Oznaczenie	IC mm	D1 mm	L mm	BS mm	S mm
SDNT 0903..	9,52	3,4	9,52	1,68	3,18

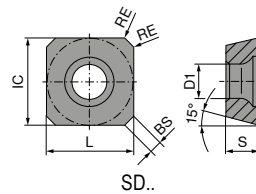

SDNT

-29
CT-P30



SDNT

51 294 ...

ISO	RE mm
0903AESN	1

EUR	CX
6,89	22006

P	●
M	○
K	○
N	
S	
H	
O	

CoreLine – Frez trzpieniowy – 210-10

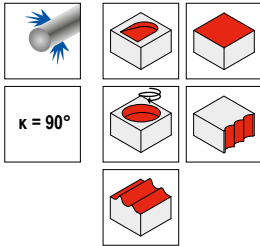

$\kappa = 90^\circ$

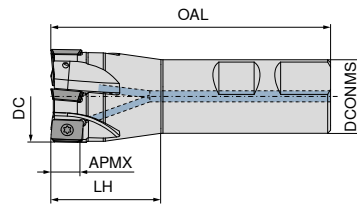

51 700 ...

Oznaczenie	DC mm	ZNF	APMX mm	OAL mm	LH mm	DCONMS mm	RPMX 1/min.	moment dociagowy Nm	Płytki wymienne	EUR CX	
C210.20.R.02-10.N	20	2	9	90	40	20	19000	1,2	AP.. 1003..	144,00	02002
C210.25.R.03-10.N	25	3	9	100	44	25	18000	1,2	AP.. 1003..	166,00	02503
C210.32.R.04-10.N	32	4	9	95	38	25	14000	1,2	AP.. 1003..	191,20	03204

CoreLine – Frez nasadzany – 210-10

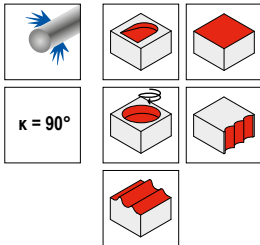

$\kappa = 90^\circ$

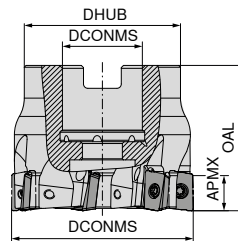

51 701 ...

Oznaczenie	DC mm	ZNF	APMX mm	OAL mm	DCONMS _{H6} mm	DHUB mm	RPMX 1/min.	moment dociagowy Nm	Płytki wymienne	EUR CX	
A210.40.R.05-10.N	40	5	9	40	22	38	12000	1,2	AP.. 1003..	220,20	04005
A210.50.R.07-10.N	50	7	9	40	22	43	11000	1,2	AP.. 1003..	275,90	05007
A210.63.R.08-10.N	63	8	9	40	22	48	9000	1,2	AP.. 1003..	302,80	06308
A210.80.R.10-10.N	80	10	9	50	27	58	8000	1,2	AP.. 1003..	383,10	08010

APKT

Oznaczenie	IC mm	D1 mm	L mm	BS mm	S mm
APKT 1003..	6,65	2,8	10,8	1,1	3,5

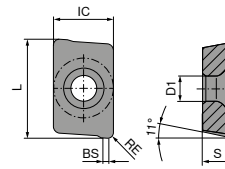

APKT

-29M
CT-P30



M
APKT

51 293 ...

EUR
CX

7,62 22006

ISO	RE mm
1003PDSR	0,5

P	●
M	○
K	○
N	
S	
H	
O	

CoreLine – Frez z chwytem gwintowym – 251-10

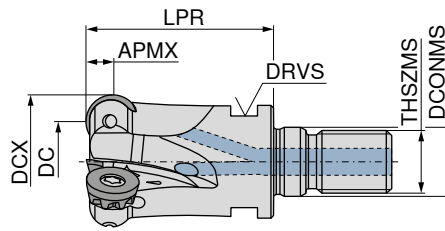
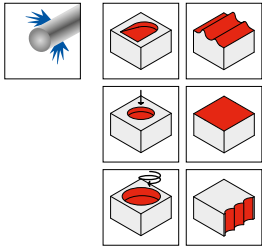

prawy

51 703 ...

Oznaczenie	DC mm	DCX mm	ZNF	APMX mm	DCONMS mm	LPR mm	THSZMS	DRVS mm	RPMX 1/min.	moment dociągowy Nm	Płytki wymienne	EUR	CX
G251.25.R.02-10.N	15	25	2	5	12,5	35	M12	17	25000	2	RP.X 10T3..	199,20	01502
G251.32.R.03-10.N	22	32	3	5	17,0	35	M16	24	21000	2	RP.X 10T3..	205,60	02203

CoreLine – Frez nasadzany – 251-10

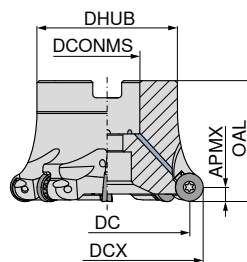
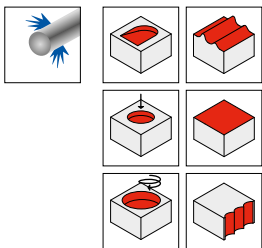

prawy

51 704 ...

Oznaczenie	DC mm	DCX mm	ZNF	APMX mm	OAL mm	DHUB mm	DCONMS _{H6} mm	RPMX 1/min.	moment dociągowy Nm	Płytki wymienne	EUR	CX
A251.40.R.03-10.N	30	40	3	5	40	38	16	14000	2	RP.X 10T3..	209,00	03003
A251.50.R.04-10.N	40	50	4	5	40	43	22	12000	2	RP.X 10T3..	221,70	04004

RPNX

Oznaczenie	IC mm	D1 mm	S mm
RPNX 10T3..	10	3,4	3,97
RPNX 1204..	12	4,4	4,76

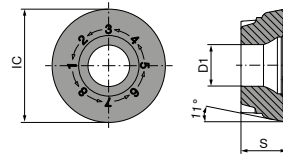

RP.X 10T3.. / RP.X 1204.. / RP.X
1605.. / RPNX 2006..

RPNX

-M50
CT-P30



RPNX

51 295 ...

ISO	EUR CX	
10T3M8SN	7,91	22006
1204M8SN	8,92	22506
P		●
M		○
K		○
N		
S		
H		
O		

XDLX

Oznaczenie	IC mm	D1 mm	L mm	BS mm	S mm	AN °
XDLX 09T3..	9,52	4,4	9	1,9	3,97	15

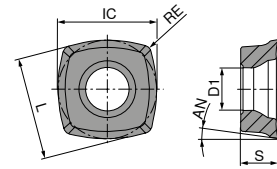

XDLX

-M50
CT-P30



XDLX

51 296 ...

EUR
CX

7,62 20806

ISO	RE mm
09T308SR	0,8

P	●
M	○
K	○
N	
S	
H	
O	

XDKT

Oznaczenie	IC mm	D1 mm	L mm	BS mm	S mm
XDKT 11T3..	6,8	2,8	10,6	1,8	3,8
XDKT 11T3..	6,8	2,8	10,6	1,4	3,8

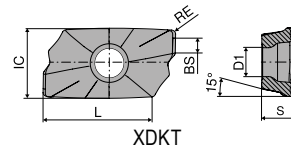

XDKT

-M50
CT-P30

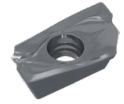

M
XDKT

51 297 ...

EUR
CX

ISO	RE mm	
11T304SR	0,4	8,05 20406
11T308SR	0,8	8,05 20806
11T312SR	1,2	8,05 21206
P		●
M		○
K		○
N		
S		
H		
O		

SDNT

Oznaczenie	IC mm	D1 mm	L mm	BS mm	S mm
SDNT 09T3..	9,52	4,4	9,52	2,5	3,97

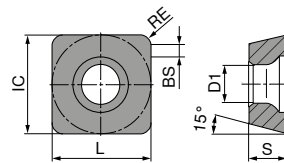

SDNT

-29
CT-P30



SDNT

51 294 ...



EUR
CX

6,89 20806

ISO	RE mm
09T308SR	0,8

P	●
M	○
K	○
N	
S	
H	
O	

Parametry skrawania

			CT-P30		
					
			Materiał skrawający twardy ($v_c \uparrow$) → ciagliwy ($v_c \downarrow$)		
			v_c (m/min)		
Podgrupa materiałów	Indeks	Wytrzymałość N/mm ² * / HB / HRC			
P	Stal niestopowa	P.1.1	420 N/mm ² / 125 HB	197	110
		P.1.2	640 N/mm ² / 190 HB	166	97
		P.1.3	840 N/mm ² / 250 HB	138	85
		P.1.4	910 N/mm ² / 270 HB	128	81
		P.1.5	1010 N/mm ² / 300 HB	114	75
	Stal niskostopowa	P.2.1	610 N/mm ² / 180 HB	171	98
		P.2.2	930 N/mm ² / 275 HB	126	80
		P.2.3	1010 N/mm ² / 300 HB	114	75
		P.2.4	1200 N/mm ² / 375 HB	78	61
	Stal wysokostopowa i wysokostopowa stal narzędziowa	P.3.1	680 N/mm ² / 200 HB	97	78
		P.3.2	1100 N/mm ² / 300 HB	86	66
		P.3.3	1300 N/mm ² / 400 HB	77	55
	Stal nierdzewna	P.4.1	680 N/mm ² / 200 HB	97	78
		P.4.2	1010 N/mm ² / 300 HB	91	72
M	Stal nierdzewna	M.1.1	610 N/mm ² / 180 HB	97	78
		M.2.1	300 HB	86	66
		M.3.1	780 N/mm ² / 230 HB	94	74
K	Żeliwo szare	K.1.1	350 N/mm ² / 180 HB	128	88
		K.1.2	500 N/mm ² / 260 HB	120	88
	Żeliwo sferoidalne	K.2.1	540 N/mm ² / 160 HB	120	88
		K.2.2	845 N/mm ² / 250 HB	120	88
	Żeliwo ciągliwe	K.3.1	440 N/mm ² / 130 HB		
		K.3.2	780 N/mm ² / 230 HB		
N	Aluminium – stop do przeróbki plastycznej	N.1.1	60 HB		
		N.1.2	340 N/mm ² / 100 HB		
	Aluminium – stop odlewniczy	N.2.1	250 N/mm ² / 75 HB		
		N.2.2	300 N/mm ² / 90 HB		
		N.2.3	440 N/mm ² / 130 HB		
	Miedź i stopy miedzi (brąz / mosiądz)	N.3.1	375 N/mm ² / 110 HB		
		N.3.2	300 N/mm ² / 90 HB		
		N.3.3	340 N/mm ² / 100 HB		
		Stopy magnezu	N.4.1	70 HB	
S	Stopy żaroodporne	S.1.1	680 N/mm ² / 200 HB		
		S.1.2	950 N/mm ² / 280 HB		
		S.2.1	840 N/mm ² / 250 HB		
		S.2.2	1180 N/mm ² / 350 HB		
		S.2.3	1080 N/mm ² / 320 HB		
	Stopy tytanu	S.3.1	400 N/mm ²		
		S.3.2	1050 N/mm ² / 320 HB		
		S.3.3	1400 N/mm ² / 410 HB		
H	Stal hartowana	H.1.1	46–55 HRC		
		H.1.2	56–60 HRC		
		H.1.3	61–65 HRC		
		H.1.4	66–70 HRC		
	Żeliwo utwardzone	H.2.1	400 HB		
Utwardzone żeliwo sferoidalne	H.3.1	55 HRC			
O	Materiały niemetalowe	O.1.1	≤ 150 N/mm ²		
		O.1.2	≤ 100 N/mm ²		
		O.2.1	≤ 1000 N/mm ²		
		O.2.2	≤ 1000 N/mm ²		
		O.3.1			

* wytrzymałość na rozciąganie

Opis gatunków

CT-P30

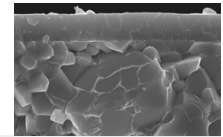

- ▲ węgiel spiekany, z powłoką
- ▲ ISO | P30 | M25 | K25
- ▲ standardowy gatunek stali do uniwersalnej obróbki stali



Parametry skrawania są zdecydowanie zależne od warunków zewnętrznych, na przykład stabilności mocowania narzędzia i przedmiotu obrabianego, materiału i typu obrabiarki! Podane wartości prezentują potencjalne parametry skrawania, które należy skorygować o ok. ±20% w zależności od warunków zastosowania narzędzia!

System 270-09

Strategia obróbki

Zagłębianie helikoidalne

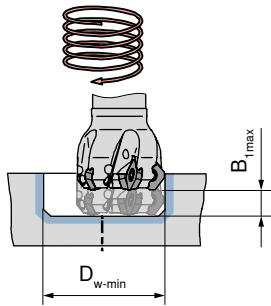

A 270-09

DC mm	D _{min} mm	B _{1 max} mm	D _{max} mm	B _{2 max} mm
40	84,5	1,5	87	1,5
50	104,5	1,5	107	1,5
63	130,5	1,5	133	1,5
80	164,5	1,5	167	1,5
100	204,5	1,5	207	1,5

Parametry początkowe

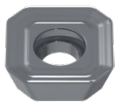

SDNT 09

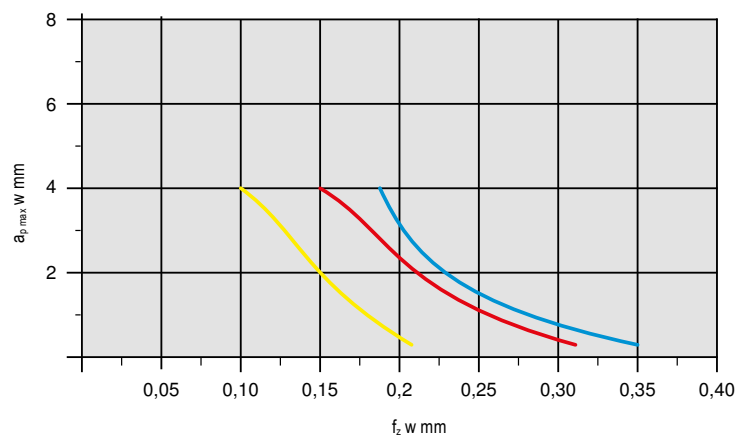

Materiał			Płytki		v _c w m/min	Chłodzenie
Stal	P.2.2	40CrMnMoS 8-6	SDNT0903AESN-29.N	CT-P30	126	Obróbka na sucho
Stal nierdzewna	M.1.1	X6CrNiMoTi 1712 2	SDNT0903AESN-29.N	CT-P30	97	Obróbka na sucho
Żeliwo	K.1.1	EN-GJL-250 (GG25)	SDNT0903AESN-29.N	CT-P30	128	Obróbka na sucho



Szczegółowe dane prędkości skrawania dla poszczególnych materiałów znajdują się na → str. 12
Od v_c > 400 m/min należy wyważyć narzędzie!

System 210-10

Strategia obróbki

Zagłębianie helikoidalne

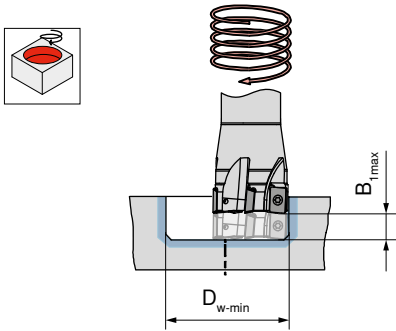

A 210-10 / C 210-10

DC mm	D _{min} mm	B _{1 max} mm	D _{max} mm	B _{2 max} mm	α _R °
20	30	1,4	38	2,6	2,7
25	40	1,5	48	2,3	1,9
32	54	1,6	62	2,2	1,3
40	70	1,7	78	2,1	1
50	90	1,6	98	1,9	0,7
63	116	1,6	124	1,8	0,5
80	150	1,5	158	1,8	0,4

Parametry początkowe

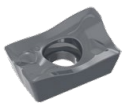

AKPT 10

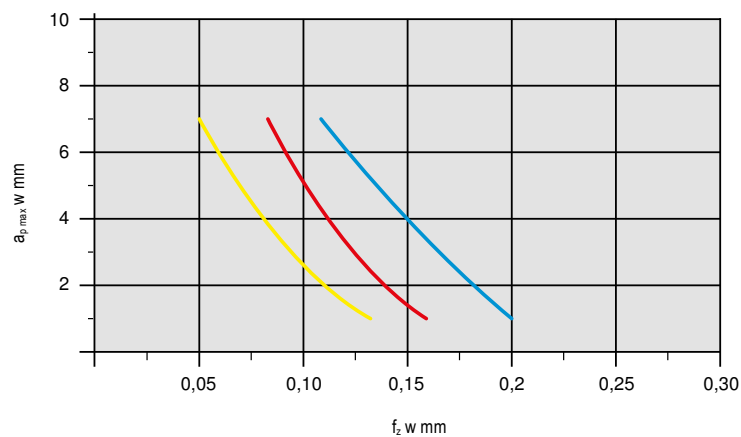

Materiał			Płytko		v _c w m/min	Chłodzenie
Stal	P.2.2	40CrMnMoS 8-6	AKPT1003PDSR-29M.N	CT-P30	126	Obróbka na sucho
Stal nierdzewna	M.1.1	X6CrNiMoTi 1712 2	AKPT1003PDSR-29M.N	CT-P30	97	Obróbka na sucho
Żeliwo	K.1.1	EN-GJL-250 (GG25)	AKPT1003PDSR-29M.N	CT-P30	128	Obróbka na sucho



Szczegółowe dane prędkości skrawania dla poszczególnych materiałów znajdują się na → str. 12
Od v_c > 400 m/min należy wyważyć narzędzie!

System 251-10

Strategia obróbki

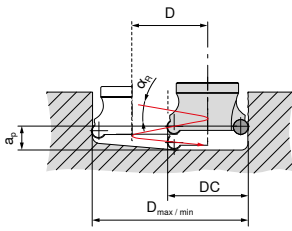

Zagłębienie helikoidalne



DC mm	D _{min.} mm	D _{max.} mm	α _R °
25	37	40	1,8
32	50	54	1,5
40	64	70	1,1
50	84	90	0,9

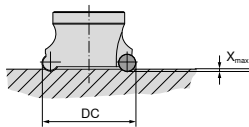

Osiowe zagłębienie się w materiał



DC mm	X _{max} mm
25	0,4
32	50
40	64
50	84

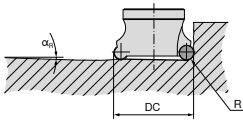

Skośne zagłębienie się w materiał



DC mm	α _R °
25	2
32	3
40	3,3
50	2,4

Parametry początkowe



RPNX 10

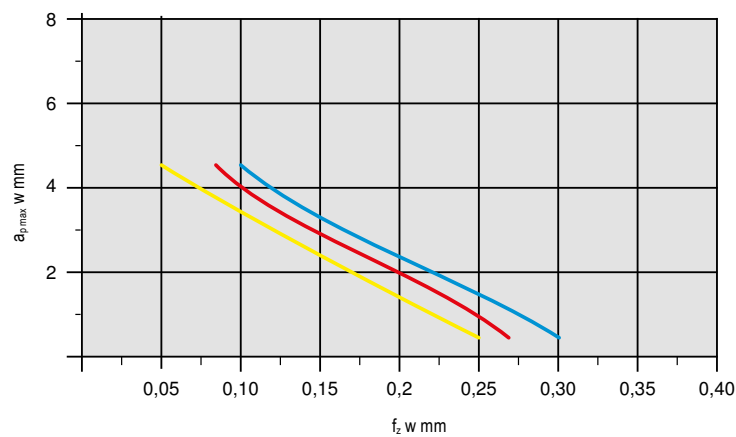

Materiał		Płytko		v _c w m/min	Chłodzenie
Stal	P.2.2 40CrMnMoS 8-6	RPNX10T3M8SN-M50.N	CT-P30	126	Obróbka na sucho
Stal nierdzewna	M.1.1 X6CrNiMoTi 1712 2	RPNX10T3M8SN-M50.N	CT-P30	97	Obróbka na sucho
Żeliwo	K.1.1 EN-GJL-250 (GG25)	RPNX10T3M8SN-M50.N	CT-P30	128	Obróbka na sucho



Szczegółowe dane prędkości skrawania dla poszczególnych materiałów znajdują się na → str. 12
Od v_c > 400 m/min należy wyważyć narzędzie!



CERATIZIT Polska Sp. z o.o.
ul. Józefa Marcika 2 \ 30-443 Kraków
Tel.: +48 12 2528570
info.polska@ceratizit.com \ www.ceratizit.com



Part of the Plansee Group

Wszelkie zmiany i ulepszenia techniczne produktów są zastrzeżone.

02/2026 - 99 033 01038