

New products for machining technicians

NEW High-performance drill type UNI



≤ 3xD

≤ 5xD

≤ 8xD

≤ 12xD

- ▲ Universal solid carbide twist drills with outstanding performance and an excellent price-performance ratio.

→ Page 18-72

NEW High-performance drill type VA



≤ 3xD

≤ 5xD

- ▲ Solid carbide twist drills designed specifically for use on corrosion-resistant and acid-resistant steels with outstanding performance and an excellent price-performance ratio.

→ Page 18-54

NEW WPC – Change



≤ 3xD

≤ 5xD

- ▲ The new modular WPC Change drilling system with replaceable cutting heads and thro' coolant enables cost-effective machining of even large holes with the performance of solid carbide drills. The drilling system is also characterised by its easy handling.



- ▲ Replaceable cutting head type UNI with wear-resistant TPX74S coating for usage on steel and cast iron materials.

→ Page 104+105



Solid drilling and bore machining

1 HSS drilling

2 Solid carbide drilling

3 Indexable insert drilling

4 Reaming and Countersinking

5 Spindle Tooling

Threading

6 Taps and thread formers

7 Circular and Thread Milling

8 Thread turning

Turning

9 Turning Tools

10 Multifunctional Tools – EcoCut and FreeTurn

11 Grooving Tools

12 Miniature turning tools

Milling

13 HSS Milling Cutters

14 Solid Carbide milling cutters

15 Milling tools with indexable inserts

Clamping technology

16 Adaptors and Accessories

17 Workpiece clamping

18 Material examples

Table of contents

Symbol explanation	4
Toolfinder	5-7
List of contents	8-12
Product programme	13-107
Technical Information:	
Cutting Data	108-156
Type overview	158
Application notes: WTX drill, WTX – Change / WPC Change, WPC – Change, deep hole twist and micro drill	159-164
Coatings	165

WNT \ Performance

Premium quality tools for high performance.

The premium quality tools from the **WNT Performance** product line have been designed for specific applications and are distinguished by their outstanding performance. If you make high demands on the performance of your production and want to achieve the very best results, we recommend the Premium tools in this product line.

WNT \ Standard

Quality tools for standard applications.

The quality tools of the **WNT Standard** product line are high quality, powerful and reliable and enjoy the highest trust of our customers worldwide. Tools from this product line are the first choice for many standard applications and guarantee optimal results.

Symbol explanation

Shank

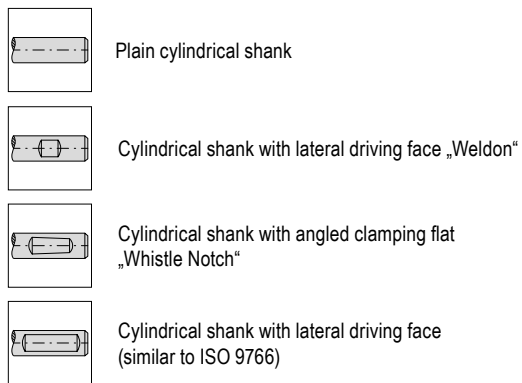

Version

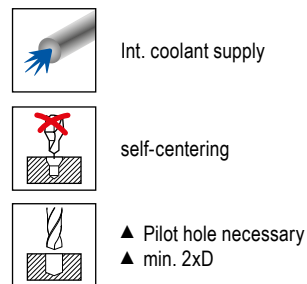

Tool types

HFDS An explanation of the tool types can be found on → **Page 158**.

- = Main Application
- = Extended application



Recommended application – WTX Performance Tools

● = Main Application
○ = Extended application

WTX – Type		Solid drilling	Flat bottom hole	High-feed machining	High speed machining	Stack plate drilling	Drilling through a transverse hole	Angled hole entrance	Angled drill exit	Drilling a precise fit	Deep holes	Miniature holes
Monobloc Tool	WTX – UNI	●				●	●					
	WTX – Speed UNI	●			●	●						
	WTX – HFDS	●		●		●	●					
	WTX – Feed UNI	●		●		●	●	●	●			
	WTX – Speed VA	●			●							
	WTX – VA	●										
	WTX – Ti	●					●					
	WTX – AL	●										
	WTX – 180	●	●				●	●	●			
	WTX – Quattro 4F	●							○			
	WTX – Feed BR	●		●		○	○	○	○	●		
	WTX – H	●										
	WTX – TB	●									●	
	WTX – Micro	●									●	●
	WTX – Mini	●										●
Modular	WTX – Change Feed UNI	●		●				●	●			
	WTX – Change Drill heads	●										

Coolant diagram

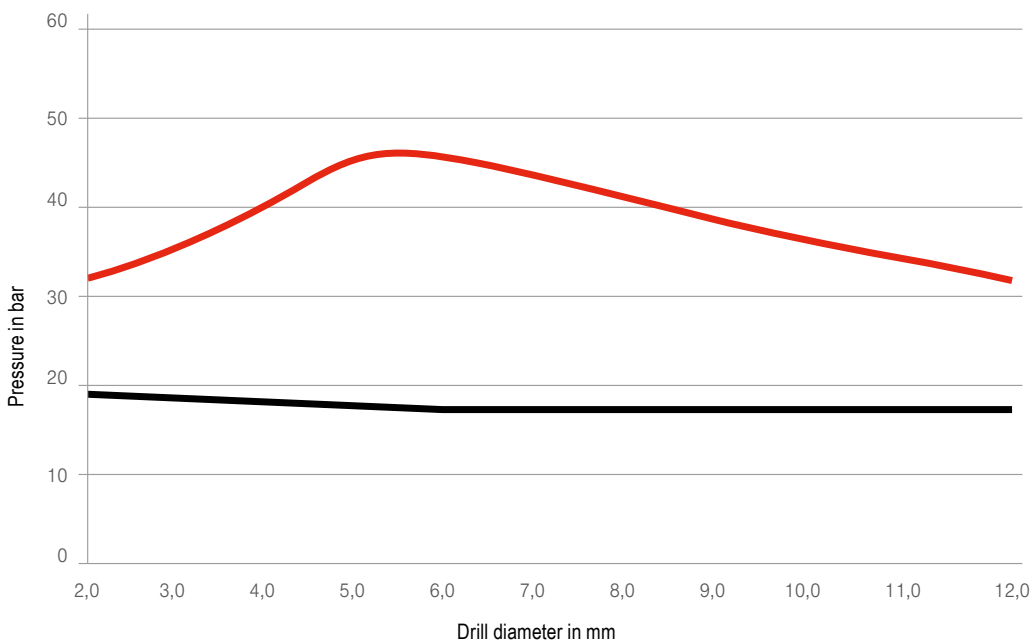

— Recommended coolant pressure
— Minimum coolant Pressure

Additional application criteria for WTX drills can be found on → [page 159](#)

Toolfinder

Product name	Tool type	Description	Int. coolant supply	Replaceable cutting heads	1xD	3xD	5xD	8xD	12xD	Video
Solid carbide drilling										
WTX	UNI	▲ highest performance for all materials up to 1200 N/mm ² ▲ suitable for volume production	✗ ✓			13-17 24-27	36-39 42-46	60-63		▶
	UNI	▲ Quality tool for standard applications ▲ Attractive price-performance ratio	✗ ✓			18-21 28-31	40 51-54	64	72	▶
WTX	Speed UNI	▲ High-performance drill for high cutting speeds ▲ Innovative DPX14S Dragonskin ▲ New cutting edge geometry	✓			24-27	42-46	60-63		▶
WTX	HFDS	▲ High-feed drill with four cutting edges ▲ Innovative cutting edge geometry enables maximum positioning accuracy ▲ Optimal cooling with four spiral coolant holes	✓			35	59			▶
WTX	Feed UNI	▲ High-feed drill with three cutting edges ▲ Suitable for difficult drilling applications ▲ High positioning accuracy	✓				58	68	73	▶
WTX	Quattro 4F	▲ with additional guide land for best alignment accuracy, concentricity and positional accuracy	✓				42-46	60-63	69-71	
WTX	180	▲ for inclined surfaces up to 45° and flat bottom holes	✓			34	57			
	N	▲ uncoated solid carbide drills ▲ universal application	✗			23	41			
Mini-drill										
WTX	MINI	▲ Available from Ø 0.1 mm ▲ Standard shank Ø 3.0 mm for use in heat shrink adapters	✗				78			
WTX	MICRO	▲ Universal high-performance micro drill ▲ Specialised geometry and coating ▲ WTX – Micro (5xD) pilot drill for deep hole twist drill	✓				79	79	80	▶
Drill Reamers										
WTX	Feed BR/BR100	▲ solid carbide high performance drill reamer ▲ excellent surface quality ▲ for blind and through holes	✓			83+85	84+85			
Stepped drills										
WTX	SB	▲ Solid carbide short step drill for core hole plus countersink for thread cutting and thread forming	✗ ✓			86 87				
NC Spot Drill										
	NC-A	▲ spiral fluted ▲ 90°, 120°, 142°	✗		88+89					
Centre drills										
	ZB	▲ spiral fluted ▲ 120°	✗		90					
Drill with replaceable cutting heads										
WTX	Change Feed UNI	▲ three-edged exchangeable head drill with solid carbide drill head type Feed UNI from Ø 14.0 mm to 32.0 mm ▲ universal application (steel, cast iron)	✓	91+92	93	93	94			▶
WTX	Change UNI	▲ exchangeable head drill with type UNI solid carbide drill head from Ø 12.0 mm to 41.0 mm ▲ for steels <700 N/mm ²	✓	95-100	101	101	102	102	103	▶
WTX	Change P	▲ exchangeable head drill with type P solid carbide drill head from Ø 12.0 mm to 41.0 mm ▲ for steels >700 N/mm ²	✓	95-100	101	101	102	102	103	▶
WPC	Change UNI	▲ Indexable insert drill with solid carbide indexable insert type UNI from Ø 14.0 to 30.0 mm ▲ Universal application on steel and cast iron materials	✓	104	105	105				
Exchangeable head NC spot drill										
	NC-A	▲ NC spot drill – exchange head system ▲ 90°, 120°, 142°	✗	107						

✗ = without through coolant

✓ = with thro' coolant

Toolfinder

	Product name	Tool type	Description	Int. coolant supply	Replaceable cutting heads	1xD	3xD	5xD	8xD	12xD	Video
Solid carbide drilling											
Stainless steel	WTX	VA	<ul style="list-style-type: none"> ▲ highest performance for corrosion and acid-resistant steels and aluminium ▲ for volume production 	<ul style="list-style-type: none"> ✗ ✓ 			13-17 24-27	36-39 47-50	65-67		
		VA	<ul style="list-style-type: none"> ▲ Quality tool for corrosion-resistant and acid-resistant steels and aluminium ▲ Attractive price-performance ratio 	<ul style="list-style-type: none"> ✗ ✓ 			18-21 28-31	51-54			
	WTX	Speed VA	<ul style="list-style-type: none"> ▲ double the cutting speed in corrosion and acid-resistant steels and aluminium 	✓				47-50		69-71	
Drill with replaceable cutting heads											
	WTX	Change VA	<ul style="list-style-type: none"> ▲ exchangeable head drill with solid carbide drill head type VA from Ø 12.0 mm to 32.0 mm 	✓	95-100	101	101	102	102	103	▶
Solid carbide drilling											
Cast iron	WTX	UNI	<ul style="list-style-type: none"> ▲ highest performance for all materials up to 1200 N/mm² ▲ suitable for volume production 	<ul style="list-style-type: none"> ✗ ✓ 			13-17 24-27	36-39 42-46	60-63		▶
	Drill with replaceable cutting heads										
	WTX	Change GG	<ul style="list-style-type: none"> ▲ exchangeable head drill with solid carbide drill head type GG from Ø 12.0 mm to 32.0 mm 	✓	95-100	101	101	102	102	103	▶
Solid carbide drilling											
Non-ferrous metals	WTX	AL	<ul style="list-style-type: none"> ▲ solid carbide high performance drill, especially for the machining of aluminum, copper and brass ▲ for volume production 	✓			47-50	65-67	69-71		
	Drill with replaceable cutting heads										
	WTX	Change AL	<ul style="list-style-type: none"> ▲ exchangeable head drill with solid carbide drill head type AL from Ø 12.0 mm to 32.0 mm 	✓	95-100	101	101	102	102	103	▶
Solid carbide drilling											
Heat-resistant	WTX	Ti	<ul style="list-style-type: none"> ▲ highest performance in titanium, titanium alloys and heat resistant alloys 	✓			32+33	55+56			
Solid carbide drilling											
Tempered steel	WTX	H	<ul style="list-style-type: none"> ▲ highest performance in hardened steel from 46 to 70 HRC 	✗			22				▶
Deep Hole Drills											
	Product name	Tool type	Description	Int. coolant supply	16xD	20xD	25xD	30xD	40xD	50xD	Video
Steel/Universal	WTX	MICRO	<ul style="list-style-type: none"> ▲ Available from Ø 0.8 mm ▲ Universal high-performance micro deep hole twist drill ▲ Specialised geometry and coating ▲ Hole depths up to 30xD possible 	✓	80	81	81	82			▶
	WTX	CP 20 UNI	<ul style="list-style-type: none"> ▲ Ensures an even safer deep hole drilling process ▲ Excellent alignment precision ▲ For optimal guidance of the deep hole twist drill for hole depths > 30xD 	✓		74					
	WTX	TB UNI	<ul style="list-style-type: none"> ▲ solid carbide deep hole drill to 50xD without peck ▲ 4 facet geometry for excellent alignment accuracy 	✓	75	75	76	76	77	77	
Non-ferrous metals	WTX	TB ALU	<ul style="list-style-type: none"> ▲ solid carbide deep hole drills, up to 30xD without pecking ▲ 6-facet head geometry for excellent alignment accuracy 	✓	75	75	76	76			

✗ = without through coolant ✓ = with thro' coolant

Overview Solid Carbide Drills

Product name	Tool type	Length	Diameter in mm Ø DC	Material	Coating	Performance
				Steel Stainless steel Cast iron Non-ferrous metals Heat-resistant Tempered steel Non metal materials	<input checked="" type="checkbox"/> coated <input type="checkbox"/> uncoated	WNT / Performance WNT / Standard
3xD without thro' coolant						
	WTX	UNI	≤ 3xD	3-25	<input checked="" type="checkbox"/>	13-17
	WTX	VA	≤ 3xD	2-20	<input checked="" type="checkbox"/>	13-17
		UNI	≤ 3xD	1-20	<input checked="" type="checkbox"/>	18-21
		VA	≤ 3xD	1-20	<input checked="" type="checkbox"/>	18-21
	WTX	H	≤ 3xD	2,55-14	<input checked="" type="checkbox"/>	up to 70 HRC 22
		N	≤ 3xD	0,5-20	<input type="checkbox"/>	23
3xD with thro' coolant						
	WTX	Speed UNI	≤ 3xD	3-20	<input checked="" type="checkbox"/>	24-27
	WTX	UNI	≤ 3xD	3-25	<input checked="" type="checkbox"/>	24-27
	WTX	VA	≤ 3xD	3-20	<input checked="" type="checkbox"/>	24-27
		UNI	≤ 3xD	1-20	<input checked="" type="checkbox"/>	28-31
		VA	≤ 3xD	1-20	<input checked="" type="checkbox"/>	28-31
	WTX	Ti	≤ 3xD	3-20	<input checked="" type="checkbox"/>	32+33
	WTX	180	≤ 3xD	3-20	<input checked="" type="checkbox"/>	34
	WTX	HFDS	≤ 3xD	6-16	<input checked="" type="checkbox"/>	4 flute 35
5xD without thro' coolant						
	WTX	UNI	≤ 5xD	3-20	<input checked="" type="checkbox"/>	36-39
	WTX	VA	≤ 5xD	3-20	<input checked="" type="checkbox"/>	36-39
		UNI	≤ 5xD	3-20	<input checked="" type="checkbox"/>	40
		N	≤ 5xD	0,5-16	<input type="checkbox"/>	41

Overview Solid Carbide Drills

Product name	Tool type	Length	Diameter in mm Ø DC	Material	Coating	Performance
				Steel Stainless steel Cast iron Non-ferrous metals Heat-resistant Tempered steel Non metal materials	<input checked="" type="checkbox"/> coated <input type="checkbox"/> uncoated	WNT / Performance WNT / Standard
5xD with thro' coolant						
	WTX	Speed UNI	≤ 5xD	3-18	<input checked="" type="checkbox"/>	42-46
	WTX	UNI	≤ 5xD	3-25	<input checked="" type="checkbox"/>	42-46
	WTX	Quattro 4F	≤ 5xD	3-18	<input checked="" type="checkbox"/>	42-46
	WTX	Speed VA	≤ 5xD	3-20	<input checked="" type="checkbox"/>	47-50
	WTX	VA	≤ 5xD	3-20	<input checked="" type="checkbox"/>	47-50
	WTX	AL	≤ 5xD	2,5-20	<input checked="" type="checkbox"/>	47-50
		UNI	≤ 5xD	1-20	<input checked="" type="checkbox"/>	51-54
		VA	≤ 5xD	1-20	<input checked="" type="checkbox"/>	51-54
	WTX	Ti	≤ 5xD	3-20	<input checked="" type="checkbox"/>	55+56
	WTX	180	≤ 5xD	3-20	<input checked="" type="checkbox"/>	57
	WTX	Feed UNI	≤ 5xD	4-20	<input checked="" type="checkbox"/>	58
	WTX	HFDS	≤ 5xD	6-16	<input checked="" type="checkbox"/>	59
8xD with thro' coolant						
	WTX	Speed UNI	≤ 8xD	3-18	<input checked="" type="checkbox"/>	60-63
	WTX	UNI	≤ 8xD	3-20	<input checked="" type="checkbox"/>	60-63
	WTX	Quattro 4F	≤ 8xD	3-18	<input checked="" type="checkbox"/>	60-63
		UNI	≤ 8xD	3-20	<input checked="" type="checkbox"/>	64
	WTX	VA	≤ 8xD	3-20	<input checked="" type="checkbox"/>	65-67
	WTX	AL	≤ 8xD	3-20	<input checked="" type="checkbox"/>	65-67
	WTX	Feed UNI	≤ 8xD	4-20	<input checked="" type="checkbox"/>	68











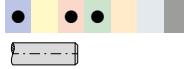

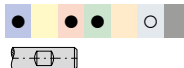

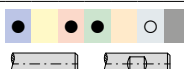













Overview Solid Carbide Drills

Product name	Tool type	Length	Diameter in mm	Material	Coating	Performance
			Ø DC	P Steel M Stainless steel K Cast iron N Non-ferrous metals S Heat-resistant H Tempered steel O Non metal materials	<input checked="" type="checkbox"/> coated <input type="checkbox"/> uncoated	WNT / Performance WNT / Standard
12xD with thro' coolant						
	WTX	Speed VA	≤ 12xD	3-17,5	● ● ● ○ ● ● ●	■ 69-71
	WTX	Quattro 4F	≤ 12xD	3-18	● ● ● ● ● ○ ● ●	■ 69-71
	WTX	AL	≤ 12xD	3-20	● ● ● ● ● ● ● ● ●	■ 69-71
		UNI	≤ 12xD	3-20	● ● ● ● ● ● ● ● ●	■ 72
	WTX	Feed UNI	≤ 12xD	4-20	● ● ● ● ● ○ ● ● ●	■ 73
Deep hole twist drill 16xD to 50xD						
	WTX	CP 20 UNI	≤ 20xD	3-9	● ● ● ● ● ● ● ● ●	■ 74
	WTX	TB UNI	≤ 16xD ≤ 20xD	2-12	● ● ● ● ● ● ● ● ●	■ 75
	WTX	TB UNI	≤ 25xD ≤ 30xD	2-12	● ● ● ● ● ● ● ● ●	■ 76
	WTX	TB UNI	≤ 40xD	3-9	● ● ● ● ● ● ● ● ●	■ 77
	WTX	TB UNI	≤ 50xD	3-6,8	● ● ● ● ● ● ● ● ●	■ 77
	WTX	TB ALU	≤ 16xD ≤ 20xD	2-12	● ● ● ● ● ● ● ● ●	■ 75
	WTX	TB ALU	≤ 25xD ≤ 30xD	2-12	● ● ● ● ● ● ● ● ●	■ 76

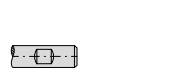
Overview Solid Carbide Drills

Product name	Tool type	Length	Diameter in mm Ø DC	Material compatibility	Coating	Performance
				Steel Stainless steel Cast iron Non-ferrous metals Heat-resistant Tempered steel Non metal materials	<input checked="" type="checkbox"/> coated <input type="checkbox"/> uncoated	WNT / Performance WNT / Standard
Micro drill 5xD to 30xD						
	WTX	MINI	≤ 5xD	0,1–2,9	<input type="checkbox"/>	78
	WTX	MICRO	≤ 5xD	0,8–2,9	<input checked="" type="checkbox"/>	79
	WTX	MICRO	≤ 8xD	0,8–2,9	<input checked="" type="checkbox"/>	79
	WTX	MICRO	≤ 12xD	0,8–2,9	<input checked="" type="checkbox"/>	80
	WTX	MICRO	≤ 16xD	0,8–2,9	<input checked="" type="checkbox"/>	80
	WTX	MICRO	≤ 20xD	0,8–2,9	<input checked="" type="checkbox"/>	81
	WTX	MICRO	≤ 25xD	0,8–2,9	<input checked="" type="checkbox"/>	81
	WTX	MICRO	≤ 30xD	0,8–2,9	<input checked="" type="checkbox"/>	82
Drill Reamers						
	WTX	Feed BR100	≤ 3xD ≤ 5xD	3,97 12,02	<input checked="" type="checkbox"/>	83+84
	WTX	Feed BR	≤ 3xD	4–16	<input checked="" type="checkbox"/>	85
	WTX	Feed BR	≤ 5xD	4–20	<input checked="" type="checkbox"/>	85
Stepped drills						
	WTX	SB		2,5–14	<input checked="" type="checkbox"/>	86
	WTX	SB		2,8–15	<input checked="" type="checkbox"/>	86
	WTX	SB		3,3–14	<input checked="" type="checkbox"/>	87
	WTX	SB		3,7–15	<input checked="" type="checkbox"/>	87

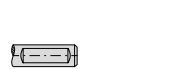
Overview Solid Carbide Drills

Product name	Tool type	Point angle	Diameter in mm	Material compatibility	Coating	Performance
SIG	Ø DC	90° 120° 142°	Steel Stainless steel Cast iron Non-ferrous metals Heat-resistant Tempered steel Non metal materials	coated uncoated	WNT / Performance WNT / Standard	
NC Spot Drill						
	NC-A	90° 120° 142°	2-20		<input type="checkbox"/>	88
	NC-A	90° 120° 142°	2-20		<input checked="" type="checkbox"/>	88
	NC-A	90° 120° 142°	3-16	 long version	<input checked="" type="checkbox"/>	89
Centre drills						
	ZB	120°	0,5-6,3		<input type="checkbox"/>	90
Drill with replaceable cutting heads						
Replaceable cutting heads						
	WTX	Change Feed	14-32		3 Edges	<input checked="" type="checkbox"/> 91+92
	WTX	Change UNI	12-41			<input checked="" type="checkbox"/> 95-100
	WTX	Change P	12-41			<input checked="" type="checkbox"/> 95-100
	WTX	Change VA	12-32			<input checked="" type="checkbox"/> 95-100
	WTX	Change GG	12-32			<input checked="" type="checkbox"/> 95-100
	WTX	Change ALU	12-32			<input checked="" type="checkbox"/> 95-100
	WPC	Change UNI	14-30			<input checked="" type="checkbox"/> 104
Tool holder						
	WTX	Change Feed	14-32		3xD / 5xD / 8xD	93+94
	WTX	Change	12-41		1xD / 3xD / 5xD / 8xD / 12xD	101-103
	WPC	Change	14-30		3xD / 5xD	105
MultiChange NC spot drill						
	NC-A	90° 120° 142°	8-20		<input checked="" type="checkbox"/>	107

WTX – High Performance Drill, DIN 6537

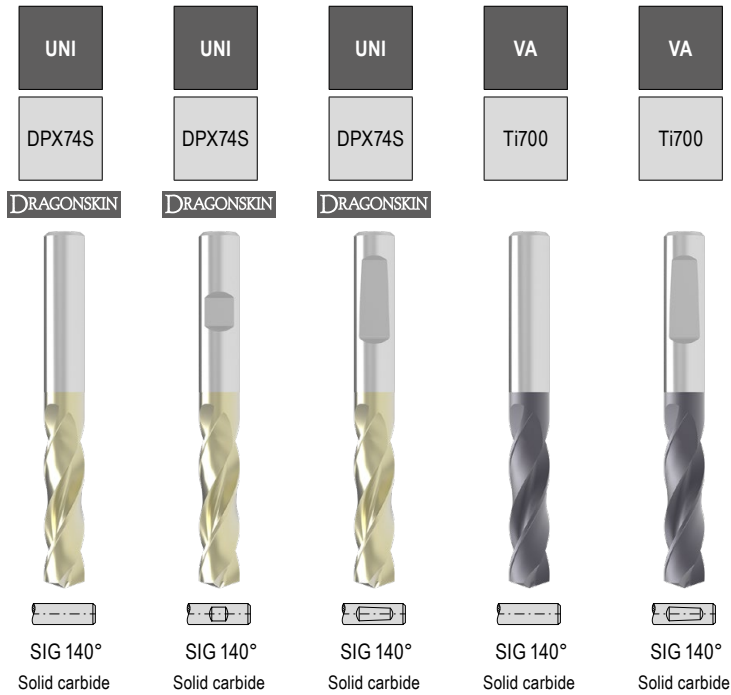
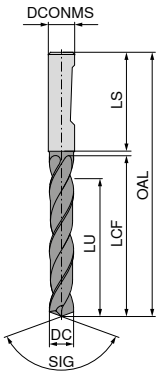
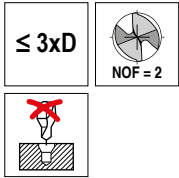

DC _{m7} mm	DCONMS _{h6} mm	OAL mm	LCF mm	LU mm	LS mm	11 777 ...		11 778 ...		11 776 ...		10 731 ...		10 732 ...	
						£ T7	03000	£ T7	03000	£ T7	03000	£ T5	020	£ T5	020
2.00	6	58	16	11	36							56.66	020	56.66	020
2.10	6	58	16	11	36							56.66	021	56.66	021
2.20	6	58	16	11	36							56.66	022	56.66	022
2.30	6	58	16	11	36							56.66	023	56.66	023
2.33	6	58	16	11	36							56.66	823		
2.40	6	58	16	11	36							56.66	024	56.66	024
2.43	6	58	16	11	36							56.66	824		
2.50	6	58	16	11	36							56.66	025	56.66	025
2.55	6	58	16	11	36							56.66	825		
2.60	6	58	16	11	36							56.66	026	56.66	026
2.62	6	58	16	11	36							56.66	826		
2.70	6	58	16	11	36							56.66	027	56.66	027
2.80	6	58	16	11	36							56.66	028	56.66	028
2.90	6	58	16	11	36							56.66	029	56.66	029
3.00	6	62	20	14	36	36.59	03000	36.59	03000	36.59	03000	74.84	030	74.84	030
3.10	6	62	20	14	36	36.59	03100	36.59	03100	36.59	03100	74.84	031	74.84	031
3.15	6	62	20	14	36	36.59	03150	36.59	03150	36.59	03150	74.84	831		
3.20	6	62	20	14	36	36.59	03200	36.59	03200	36.59	03200	74.84	032	74.84	032
3.22	6	62	20	14	36	36.59	03220	36.59	03220	36.59	03220	74.84	832		
3.25	6	62	20	14	36	36.59	03250	36.59	03250	36.59	03250	74.84	890		
3.30	6	62	20	14	36	36.59	03300	36.59	03300	36.59	03300	74.84	033	74.84	033
3.40	6	62	20	14	36	36.59	03400	36.59	03400	36.59	03400	74.84	034	74.84	034
3.50	6	62	20	14	36	36.59	03500	36.59	03500	36.59	03500	74.84	035	74.84	035
3.60	6	62	20	14	36	36.59	03600	36.59	03600	36.59	03600	74.84	036	74.84	036
3.70	6	62	20	14	36	36.59	03700	36.59	03700	36.59	03700	74.84	037	74.84	037
3.80	6	66	24	17	36	36.59	03800	36.59	03800	36.59	03800	74.84	038	74.84	038
3.85	6	66	24	17	36	36.59	03850	36.59	03850	36.59	03850	74.84	838		
3.90	6	66	24	17	36	36.59	03900	36.59	03900	36.59	03900	74.84	039	74.84	039
4.00	6	66	24	17	36	36.59	04000	36.59	04000	36.59	04000	74.84	040	74.84	040
4.10	6	66	24	17	36	36.59	04100	36.59	04100	36.59	04100	74.84	041	74.84	041
4.20	6	66	24	17	36	36.59	04200	36.59	04200	36.59	04200	74.84	042	74.84	042
4.25	6	66	24	17	36	36.59	04250	36.59	04250	36.59	04250				
4.30	6	66	24	17	36	36.59	04300	36.59	04300	36.59	04300	74.84	043	74.84	043
4.35	6	66	24	17	36	36.59	04350	36.59	04350	36.59	04350	74.84	843		
4.40	6	66	24	17	36	36.59	04400	36.59	04400	36.59	04400	74.84	044	74.84	044
4.45	6	66	24	17	36	36.59	04450	36.59	04450	36.59	04450	74.84	844		
4.50	6	66	24	17	36	36.59	04500	36.59	04500	36.59	04500	74.84	045	74.84	045
4.60	6	66	24	17	36	36.59	04600	36.59	04600	36.59	04600	74.84	046	74.84	046
4.65	6	66	24	17	36	36.59	04650	36.59	04650	36.59	04650	74.84	900	74.84	900
4.70	6	66	24	17	36	36.59	04700	36.59	04700	36.59	04700	74.84	047	74.84	047
4.80	6	66	28	20	36	36.59	04800	36.59	04800	36.59	04800	74.84	048	74.84	048
P							●		●		●		○		○
M													●		●
K							●		●		●		○		○
N													○		○
S													●		●
H							○		○		○				
O															

WTX – High Performance Drill, DIN 6537

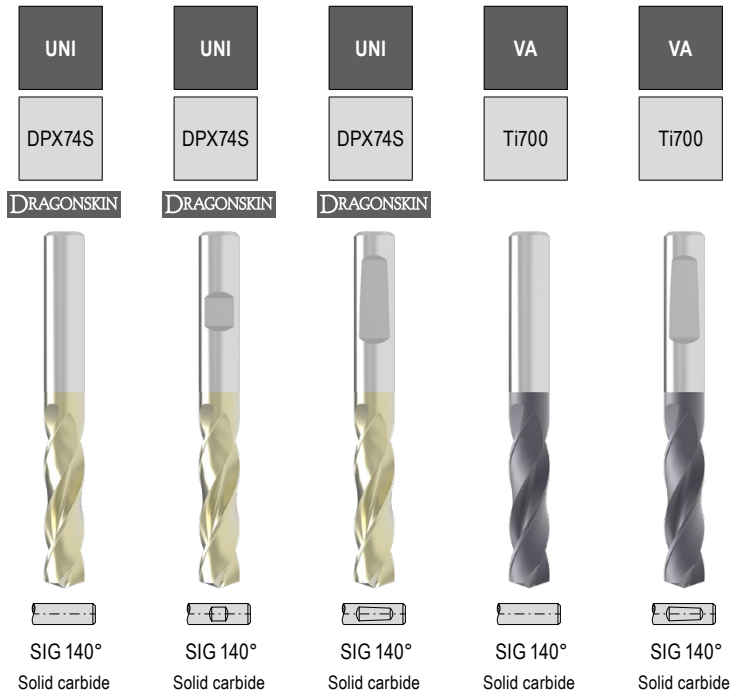
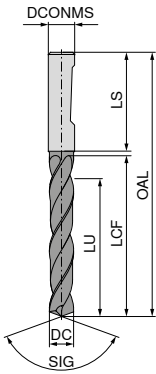
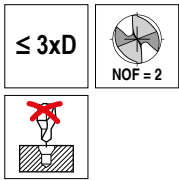

11 777 ... 11 778 ... 11 776 ... 10 731 ... 10 732 ...

DC _{m7} mm	DCONMS _{h6} mm	OAL mm	LCF mm	LU mm	LS mm	11 777 ...		11 778 ...		11 776 ...		10 731 ...		10 732 ...	
						£ T7	04900	£ T7	04900	£ T7	04900	£ T5	049	£ T5	049
4.90	6	66	28	20	36	36.59	04900	36.59	04900	36.59	04900	74.84	049	74.84	049
4.95	6	66	28	20	36	36.59	04950	36.59	04950	36.59	04950				
5.00	6	66	28	20	36	36.59	05000	36.59	05000	36.59	05000	74.84	050	74.84	050
5.05	6	66	28	20	36	36.59	05050	36.59	05050	36.59	05050				
5.10	6	66	28	20	36	36.59	05100	36.59	05100	36.59	05100	74.84	051	74.84	051
5.20	6	66	28	20	36	36.59	05200	36.59	05200	36.59	05200	74.84	052	74.84	052
5.30	6	66	28	20	36	36.59	05300	36.59	05300	36.59	05300	74.84	053	74.84	053
5.40	6	66	28	20	36	36.59	05400	36.59	05400	36.59	05400	74.84	054	74.84	054
5.50	6	66	28	20	36	36.59	05500	36.59	05500	36.59	05500	74.84	055	74.84	055
5.55	6	66	28	20	36	36.59	05550	36.59	05550	36.59	05550	74.84	902	74.84	902
5.60	6	66	28	20	36	36.59	05600	36.59	05600	36.59	05600	74.84	056	74.84	056
5.70	6	66	28	20	36	36.59	05700	36.59	05700	36.59	05700	74.84	057	74.84	057
5.75	6	66	28	20	36	36.59	05750	36.59	05750	36.59	05750	74.84	916		
5.80	6	66	28	20	36	36.59	05800	36.59	05800	36.59	05800	74.84	058	74.84	058
5.90	6	66	28	20	36	36.59	05900	36.59	05900	36.59	05900	74.84	059	74.84	059
5.95	6	66	28	20	36	36.59	05950	36.59	05950	36.59	05950	74.84	959		
6.00	6	66	28	20	36	36.59	06000	36.59	06000	36.59	06000	74.84	060	74.84	060
6.10	8	79	34	24	36	39.46	06100	39.46	06100	39.46	06100	95.06	061	95.06	061
6.20	8	79	34	24	36	39.46	06200	39.46	06200	39.46	06200	95.06	062	95.06	062
6.30	8	79	34	24	36	39.46	06300	39.46	06300	39.46	06300	95.06	063	95.06	063
6.40	8	79	34	24	36	39.46	06400	39.46	06400	39.46	06400	95.06	064	95.06	064
6.50	8	79	34	24	36	39.46	06500	39.46	06500	39.46	06500	95.06	065	95.06	065
6.60	8	79	34	24	36	39.46	06600	39.46	06600	39.46	06600	95.06	066	95.06	066
6.70	8	79	34	24	36	39.46	06700	39.46	06700	39.46	06700	95.06	067	95.06	067
6.80	8	79	34	24	36	39.46	06800	39.46	06800	39.46	06800	95.06	068	95.06	068
6.90	8	79	34	24	36	39.46	06900	39.46	06900	39.46	06900	95.06	069	95.06	069
7.00	8	79	34	24	36	39.46	07000	39.46	07000	39.46	07000	95.06	070	95.06	070
7.10	8	79	41	29	36	39.46	07100	39.46	07100	39.46	07100	95.06	071	95.06	071
7.20	8	79	41	29	36	39.46	07200	39.46	07200	39.46	07200	95.06	072	95.06	072
7.30	8	79	41	29	36	39.46	07300	39.46	07300	39.46	07300	95.06	073	95.06	073
7.40	8	79	41	29	36	39.46	07400	39.46	07400	39.46	07400	95.06	074	95.06	074
7.45	8	79	41	29	36	39.46	07450	39.46	07450	39.46	07450	95.06	924		
7.50	8	79	41	29	36	39.46	07500	39.46	07500	39.46	07500	95.06	075	95.06	075
7.60	8	79	41	29	36	39.46	07600	39.46	07600	39.46	07600	95.06	076	95.06	076
7.70	8	79	41	29	36	39.46	07700	39.46	07700	39.46	07700	95.06	077	95.06	077
7.80	8	79	41	29	36	39.46	07800	39.46	07800	39.46	07800	95.06	078	95.06	078
7.90	8	79	41	29	36	39.46	07900	39.46	07900	39.46	07900	95.06	079	95.06	079
8.00	8	79	41	29	36	39.46	08000	39.46	08000	39.46	08000	95.06	080	95.06	080
8.10	10	89	47	35	40	43.28	08100	43.28	08100	43.28	08100	113.32	081	113.32	081
8.20	10	89	47	35	40	43.28	08200	43.28	08200	43.28	08200	113.32	082	113.32	082
8.30	10	89	47	35	40	43.28	08300	43.28	08300	43.28	08300	113.32	083	113.32	083

P	●	●	●	○	○
M				●	●
K	●	●	●	○	○
N				○	○
S				●	●
H	○	○	○		
O					

WTX – High Performance Drill, DIN 6537

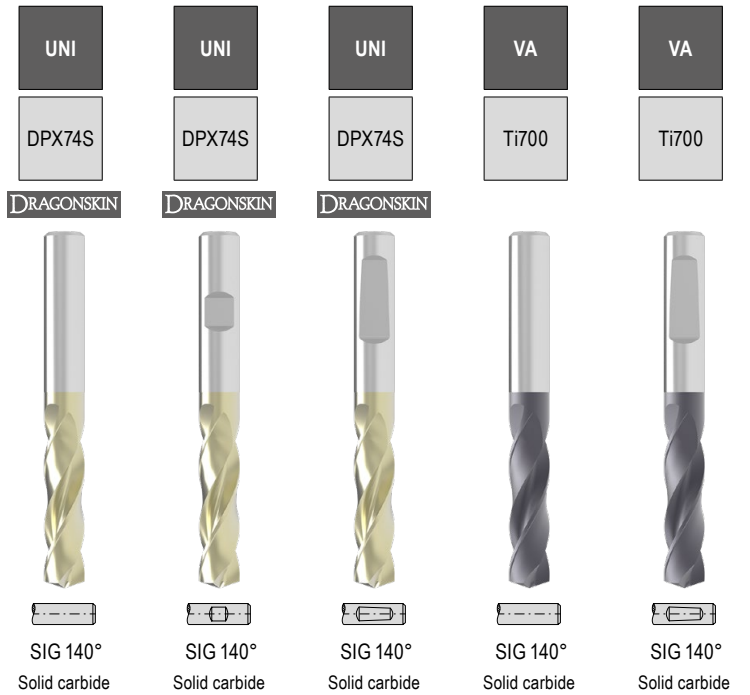
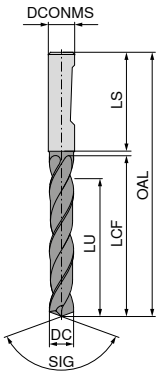
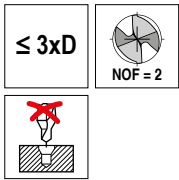

DC _{m7} mm	DCONMS _{h6} mm	OAL mm	LCF mm	LU mm	LS mm	11 777 ...		11 778 ...		11 776 ...		10 731 ...		10 732 ...	
						£ T7	08400	£ T7	08400	£ T7	08400	£ T5	084	£ T5	084
8.40	10	89	47	35	40	43.28	08400	43.28	08400	43.28	08400	113.32	084	113.32	084
8.50	10	89	47	35	40	43.28	08500	43.28	08500	43.28	08500	113.32	085	113.32	085
8.60	10	89	47	35	40	43.28	08600	43.28	08600	43.28	08600	113.32	086	113.32	086
8.70	10	89	47	35	40	43.28	08700	43.28	08700	43.28	08700	113.32	087	113.32	087
8.80	10	89	47	35	40	43.28	08800	43.28	08800	43.28	08800	113.32	088	113.32	088
8.90	10	89	47	35	40	43.28	08900	43.28	08900	43.28	08900	113.32	089	113.32	089
9.00	10	89	47	35	40	43.28	09000	43.28	09000	43.28	09000	113.32	090	113.32	090
9.10	10	89	47	35	40	43.28	09100	43.28	09100	43.28	09100	113.32	091	113.32	091
9.20	10	89	47	35	40	43.28	09200	43.28	09200	43.28	09200	113.32	092	113.32	092
9.30	10	89	47	35	40	43.28	09300	43.28	09300	43.28	09300	113.32	093	113.32	093
9.35	10	89	47	35	40	43.28	09350	43.28	09350	43.28	09350	113.32	930		
9.40	10	89	47	35	40	43.28	09400	43.28	09400	43.28	09400	113.32	094	113.32	094
9.45	10	89	47	35	40	43.28	09450	43.28	09450	43.28	09450	113.32	994		
9.50	10	89	47	35	40	43.28	09500	43.28	09500	43.28	09500	113.32	095	113.32	095
9.60	10	89	47	35	40	43.28	09600	43.28	09600	43.28	09600	113.32	096	113.32	096
9.70	10	89	47	35	40	43.28	09700	43.28	09700	43.28	09700	113.32	097	113.32	097
9.80	10	89	47	35	40	43.28	09800	43.28	09800	43.28	09800	113.32	098	113.32	098
9.90	10	89	47	35	40	43.28	09900	43.28	09900	43.28	09900	113.32	099	113.32	099
10.00	10	89	47	35	40	43.28	10000	43.28	10000	43.28	10000	113.32	100	113.32	100
10.10	12	102	55	40	45	62.72	10100	62.72	10100	62.72	10100	160.77	101	160.77	101
10.20	12	102	55	40	45	62.72	10200	62.72	10200	62.72	10200	160.77	102	160.77	102
10.30	12	102	55	40	45	62.72	10300	62.72	10300	62.72	10300	160.77	103	160.77	103
10.40	12	102	55	40	45	62.72	10400	62.72	10400	62.72	10400	160.77	104	160.77	104
10.50	12	102	55	40	45	62.72	10500	62.72	10500	62.72	10500	160.77	105	160.77	105
10.55	12	102	55	40	45	62.72	10550	62.72	10550	62.72	10550	160.77	932		
10.60	12	102	55	40	45	62.72	10600	62.72	10600	62.72	10600	160.77	106	160.77	106
10.70	12	102	55	40	45	62.72	10700	62.72	10700	62.72	10700	160.77	107	160.77	107
10.75	12	102	55	40	45	62.72	10750	62.72	10750	62.72	10750				
10.80	12	102	55	40	45	62.72	10800	62.72	10800	62.72	10800	160.77	108	160.77	108
10.90	12	102	55	40	45	62.72	10900	62.72	10900	62.72	10900	160.77	109	160.77	109
11.00	12	102	55	40	45	62.72	11000	62.72	11000	62.72	11000	160.77	110	160.77	110
11.10	12	102	55	40	45	62.72	11100	62.72	11100	62.72	11100	160.77	111	160.77	111
11.20	12	102	55	40	45	62.72	11200	62.72	11200	62.72	11200	160.77	112	160.77	112
11.25	12	102	55	40	45	62.72	11250	62.72	11250	62.72	11250	160.77	912		
11.30	12	102	55	40	45	62.72	11300	62.72	11300	62.72	11300	160.77	113	160.77	113
11.35	12	102	55	40	45	62.72	11350	62.72	11350	62.72	11350	160.77	913		
11.40	12	102	55	40	45	62.72	11400	62.72	11400	62.72	11400	160.77	114	160.77	114
11.45	12	102	55	40	45	62.72	11450	62.72	11450	62.72	11450	160.77	914		
11.50	12	102	55	40	45	62.72	11500	62.72	11500	62.72	11500	160.77	115	160.77	115
11.60	12	102	55	40	45	62.72	11600	62.72	11600	62.72	11600	160.77	116	160.77	116
11.70	12	102	55	40	45	62.72	11700	62.72	11700	62.72	11700	160.77	117	160.77	117

P	●	●	●	○	○
M	●	●	●	●	●
K	●	●	●	○	○
N				○	○
S				●	●
H	○	○	○		
O					

WTX – High Performance Drill, DIN 6537

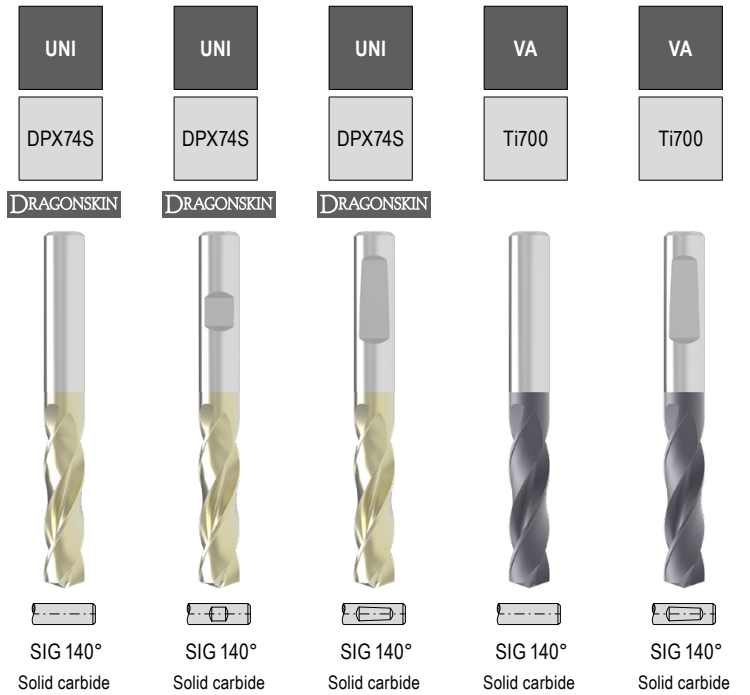
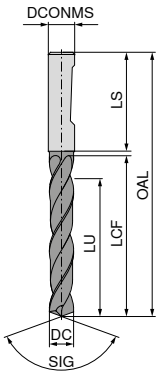
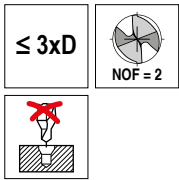

DC _{m7} mm	DCONMS _{h6} mm	OAL mm	LCF mm	LU mm	LS mm	11 777 ...		11 778 ...		11 776 ...		10 731 ...		10 732 ...	
						£ T7	11800	£ T7	11800	£ T7	11800	£ T5	118	£ T5	118
11.80	12	102	55	40	45	62.72	11800	62.72	11800	62.72	11800	160.77	118	160.77	118
11.90	12	102	55	40	45	62.72	11900	62.72	11900	62.72	11900	160.77	119	160.77	119
12.00	12	102	55	40	45	62.72	12000	62.72	12000	62.72	12000	160.77	120	160.77	120
12.15	14	107	60	43	45	81.80	12150	81.80	12150	81.80	12150	212.92	921		
12.25	14	107	60	43	45	81.80	12250	81.80	12250	81.80	12250				
12.50	14	107	60	43	45	81.80	12500	81.80	12500	81.80	12500	212.92	125	212.92	125
12.55	14	107	60	43	45	81.80	12550	81.80	12550	81.80	12550	212.92	925		
12.70	14	107	60	43	45	81.80	12700	81.80	12700	81.80	12700				
12.80	14	107	60	43	45	81.80	12800	81.80	12800	81.80	12800	212.92	128	212.92	128
12.90	14	107	60	43	45	81.80	12900	81.80	12900	81.80	12900				
13.00	14	107	60	43	45	81.80	13000	81.80	13000	81.80	13000	212.92	130	212.92	130
13.10	14	107	60	43	45	81.80	13100	81.80	13100	81.80	13100				
13.30	14	107	60	43	45	81.80	13300	81.80	13300	81.80	13300				
13.35	14	107	60	43	45	81.80	13350	81.80	13350	81.80	13350	212.92	933		
13.50	14	107	60	43	45	81.80	13500	81.80	13500	81.80	13500	212.92	135	212.92	135
13.70	14	107	60	43	45	81.80	13700	81.80	13700	81.80	13700				
13.80	14	107	60	43	45	81.80	13800	81.80	13800	81.80	13800	212.92	138	212.92	138
14.00	14	107	60	43	45	81.80	14000	81.80	14000	81.80	14000	212.92	140	212.92	140
14.20	16	115	65	45	48	106.64	14200	106.64	14200	106.64	14200				
14.50	16	115	65	45	48	106.64	14500	106.64	14500	106.64	14500	262.66	145	262.66	145
14.80	16	115	65	45	48	106.64	14800	106.64	14800	106.64	14800	262.66	148	262.66	148
15.00	16	115	65	45	48	106.64	15000	106.64	15000	106.64	15000	262.66	150	262.66	150
15.10	16	115	65	45	48	106.64	15100	106.64	15100	106.64	15100				
15.25	16	115	65	45	48	106.64	15250	106.64	15250	106.64	15250				
15.30	16	115	65	45	48	106.64	15300	106.64	15300	106.64	15300				
15.35	16	115	65	45	48	106.64	15350	106.64	15350	106.64	15350	262.66	953		
15.50	16	115	65	45	48	106.64	15500	106.64	15500	106.64	15500	262.66	155	262.66	155
15.60	16	115	65	45	48	106.64	15600	106.64	15600	106.64	15600				
15.80	16	115	65	45	48	106.64	15800	106.64	15800	106.64	15800	262.66	158	262.66	158
16.00	16	115	65	45	48	106.64	16000	106.64	16000	106.64	16000	262.66	160	262.66	160
16.05	18	123	73	51	48	208.06	16050	208.06	16050	208.06	16050	384.94	960		
16.50	18	123	73	51	48	208.06	16500	208.06	16500	208.06	16500	384.94	165	384.94	165
16.80	18	123	73	51	48	208.06	16800	208.06	16800	208.06	16800	384.94	168	384.94	168
16.90	18	123	73	51	48	208.06	16900	208.06	16900	208.06	16900				
17.00	18	123	73	51	48	208.06	17000	208.06	17000	208.06	17000	384.94	170	384.94	170
17.50	18	123	73	51	48	208.06	17500	208.06	17500	208.06	17500	384.94	175	384.94	175
17.60	18	123	73	51	48	208.06	17600	208.06	17600	208.06	17600				
17.80	18	123	73	51	48	208.06	17800	208.06	17800	208.06	17800	384.94	178	384.94	178
18.00	18	123	73	51	48	208.06	18000	208.06	18000	208.06	18000	384.94	180	384.94	180
18.50	20	131	79	55	50	231.14	18500	231.14	18500	231.14	18500	509.47	185	509.47	185
18.80	20	131	79	55	50	231.14	18800	231.14	18800	231.14	18800	509.47	188	509.47	188

P	●	●	●	○	○
M				●	●
K	●	●	●	○	○
N				○	○
S				●	●
H	○	○	○		
O					

WTX – High Performance Drill, DIN 6537

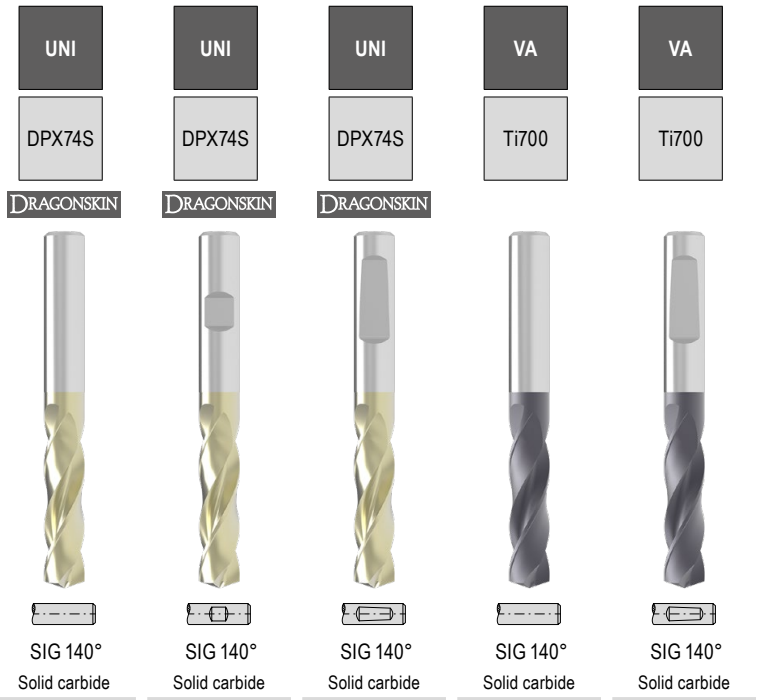
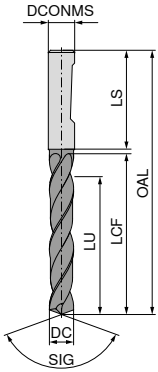
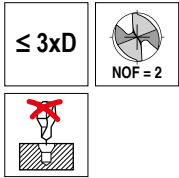

SIG 140° Solid carbide

DC _{m7} mm	DCONMS _{h6} mm	OAL mm	LCF mm	LU mm	LS mm	11 777 ...		11 778 ...		11 776 ...		10 731 ...		10 732 ...	
						£ T7	18900	£ T7	18900	£ T7	18900	£ T5	190	£ T5	190
18.90	20	131	79	55	50	231.14	18900	231.14	18900	231.14	18900				
19.00	20	131	79	55	50	231.14	19000	231.14	19000	231.14	19000	509.47	190	509.47	190
19.35	20	131	79	55	50	231.14	19350	231.14	19350	231.14	19350	509.47	993	509.47	993
19.50	20	131	79	55	50	231.14	19500	231.14	19500	231.14	19500	509.47	195	509.47	195
19.60	20	131	79	55	50	231.14	19600	231.14	19600	231.14	19600				
19.80	20	131	79	55	50	231.14	19800	231.14	19800	231.14	19800	509.47	198	509.47	198
20.00	20	131	79	55	50	231.14	20000	231.14	20000	231.14	20000	509.47	200	509.47	200
20.50	25	151	93	66	56	417.67	20500	417.67	20500	417.67	20500				
21.00	25	151	93	66	56	417.67	21000	417.67	21000	417.67	21000				
21.50	25	151	93	66	56	417.67	21500	417.67	21500	417.67	21500				
22.00	25	151	93	66	56	417.67	22000	417.67	22000	417.67	22000				
22.50	25	153	96	72	56	417.67	22500	417.67	22500	417.67	22500				
23.00	25	153	96	72	56	417.67	23000	417.67	23000	417.67	23000				
23.50	25	153	96	72	56	417.67	23500	417.67	23500	417.67	23500				
24.00	25	153	96	72	56	417.67	24000	417.67	24000	417.67	24000				
24.50	25	153	96	75	56	417.67	24500	417.67	24500	417.67	24500				
25.00	25	153	96	75	56	417.67	25000	417.67	25000	417.67	25000				

P	•	•	•	○	○
M				•	•
K	•	•	•	○	○
N				○	○
S				•	•
H	○	○	○		
O					

→ v_c Page 114+116

High Performance Drill, DIN 6537

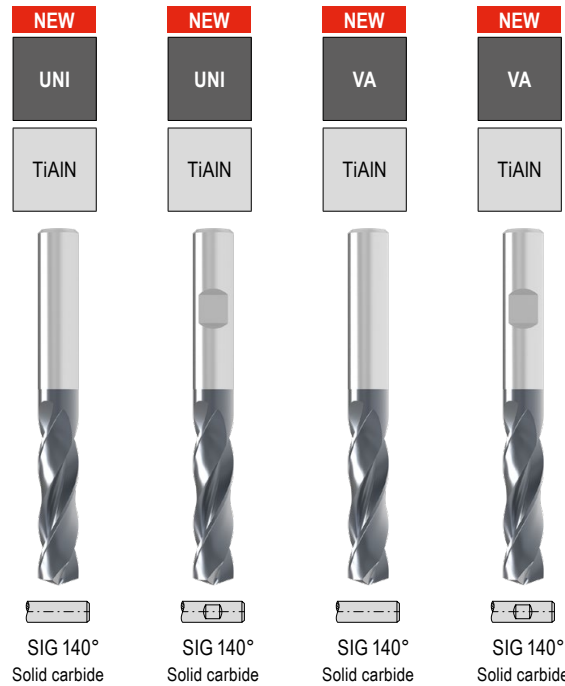
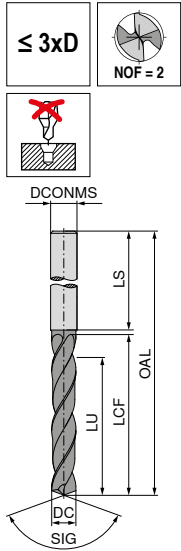

DC _{m7/h7} mm	DCONMS _{h6} mm	OAL mm	LCF mm	LU mm	LS mm
1.00	4	45	7	5.5	28
1.10	4	45	7	5.3	28
1.20	4	45	7	5.2	28
1.30	4	45	7	5.0	28
1.40	4	45	7	4.9	28
1.50	4	55	14	11.7	28
1.60	4	55	14	11.6	28
1.70	4	55	14	11.4	28
1.80	4	55	14	11.3	28
1.90	4	55	14	11.1	28
2.00	4	55	20	17.0	28
2.10	4	55	20	16.8	28
2.20	4	55	20	16.7	28
2.30	4	55	20	16.5	28
2.40	4	55	20	16.4	28
2.50	4	55	20	16.2	28
2.60	4	55	20	16.1	28
2.70	4	55	20	15.9	28
2.80	4	55	20	15.8	28
2.90	4	55	20	15.6	28
3.00	6	62	20	15.5	36
3.10	6	62	20	15.3	36
3.20	6	62	20	15.2	36
3.25	6	62	20	15.1	36
3.30	6	62	20	15.0	36
3.40	6	62	20	14.9	36
3.50	6	62	20	14.7	36
3.60	6	62	20	14.6	36
3.70	6	62	20	14.4	36
3.80	6	66	24	18.3	36
3.90	6	66	24	18.1	36
4.00	6	66	24	18.0	36
4.10	6	66	24	17.8	36
4.20	6	66	24	17.7	36
4.30	6	66	24	17.5	36
4.40	6	66	24	17.4	36
4.50	6	66	24	17.2	36
4.60	6	66	24	17.1	36
4.65	6	66	24	17.0	36

11 706 ...		11 707 ...		11 711 ...		11 712 ...	
£		£		£		£	
T1/9C		T1/9C		T1/9C		T1/9C	
27.81	01000			31.84	01000		
27.81	01100			31.84	01100		
27.81	01200			31.84	01200		
27.81	01300			31.84	01300		
27.81	01400			31.84	01400		
27.81	01500			31.84	01500		
27.81	01600			31.84	01600		
27.81	01700			31.84	01700		
27.81	01800			31.84	01800		
27.81	01900			31.84	01900		
25.40	02000			29.01	02000		
25.40	02100			29.01	02100		
25.40	02200			29.01	02200		
25.40	02300			29.01	02300		
25.40	02400			29.01	02400		
25.40	02500			29.01	02500		
25.40	02600			29.01	02600		
25.40	02700			29.01	02700		
25.40	02800			29.01	02800		
25.40	02900			29.01	02900		
24.19	03000	24.19	03000	28.12	03000	28.12	03000
24.19	03100	24.19	03100	28.12	03100	28.12	03100
24.19	03200	24.19	03200	28.12	03200	28.12	03200
24.19	03250	24.19	03250				
24.19	03300	24.19	03300	28.12	03300	28.12	03300
24.19	03400	24.19	03400	28.12	03400	28.12	03400
24.19	03500	24.19	03500	28.12	03500	28.12	03500
24.19	03600	24.19	03600	28.12	03600	28.12	03600
24.19	03700	24.19	03700	28.12	03700	28.12	03700
24.19	03800	24.19	03800	28.12	03800	28.12	03800
24.19	03900	24.19	03900	28.12	03900	28.12	03900
24.19	04000	24.19	04000	28.12	04000	28.12	04000
24.19	04100	24.19	04100	28.12	04100	28.12	04100
24.19	04200	24.19	04200	28.12	04200	28.12	04200
24.19	04300	24.19	04300	28.12	04300	28.12	04300
24.19	04400	24.19	04400	28.12	04400	28.12	04400
24.19	04500	24.19	04500	28.12	04500	28.12	04500
24.19	04600	24.19	04600	28.12	04600	28.12	04600
24.19	04650	24.19	04650				

P	●	●	○	○
M			●	●
K	●	●		
N			○	○
S			○	○
H				
O			○	○

→ v. Page 128+132

Ø DC_{h7} for Type UNI / Ø DC_{m7} for Type VA

High Performance Drill, DIN 6537

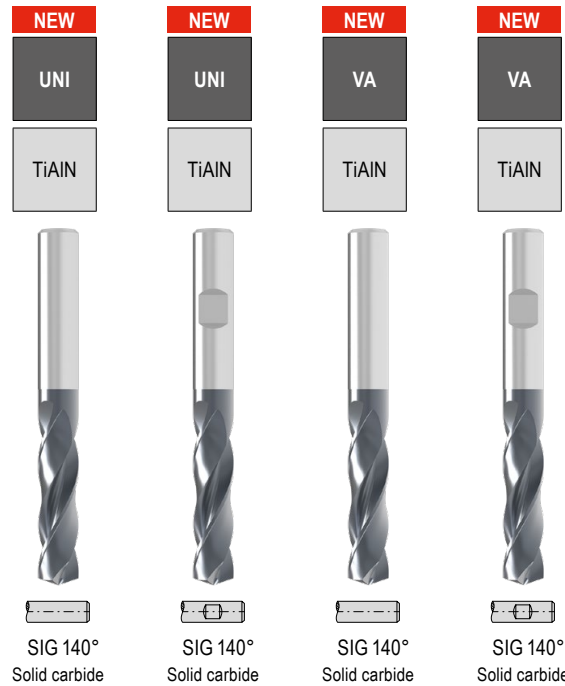
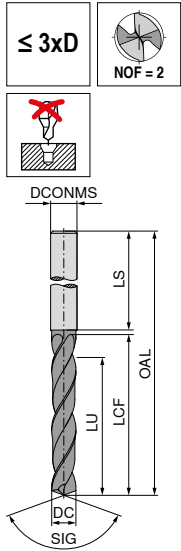

DC _{m7/h7} mm	DCONMS _{h6} mm	OAL mm	LCF mm	LU mm	LS mm
4.70	6	66	24	16.9	36
4.80	6	66	28	20.8	36
4.90	6	66	28	20.6	36
5.00	6	66	28	20.5	36
5.10	6	66	28	20.3	36
5.20	6	66	28	20.2	36
5.30	6	66	28	20.0	36
5.40	6	66	28	19.9	36
5.50	6	66	28	19.7	36
5.55	6	66	28	19.6	36
5.60	6	66	28	19.6	36
5.65	6	66	28	19.5	36
5.70	6	66	28	19.4	36
5.80	6	66	28	19.3	36
5.90	6	66	28	19.1	36
6.00	6	66	28	19.0	36
6.10	8	79	34	24.8	36
6.20	8	79	34	24.7	36
6.30	8	79	34	24.5	36
6.40	8	79	34	24.4	36
6.50	8	79	34	24.2	36
6.60	8	79	34	24.1	36
6.70	8	79	34	23.9	36
6.80	8	79	34	23.8	36
6.90	8	79	34	23.6	36
7.00	8	79	34	23.5	36
7.10	8	79	41	30.3	36
7.20	8	79	41	30.2	36
7.30	8	79	41	30.0	36
7.40	8	79	41	29.9	36
7.50	8	79	41	29.7	36
7.55	8	79	41	29.6	36
7.60	8	79	41	29.6	36
7.65	8	79	41	29.5	36
7.70	8	79	41	29.4	36
7.80	8	79	41	29.3	36
7.90	8	79	41	29.1	36
8.00	8	79	41	29.0	36
8.10	10	89	47	34.8	40

11 706 ...		11 707 ...		11 711 ...		11 712 ...	
£		£		£		£	
T1/9C		T1/9C		T1/9C		T1/9C	
24.19	04700	24.19	04700	28.12	04700	28.12	04700
24.19	04800	24.19	04800	28.12	04800	28.12	04800
24.19	04900	24.19	04900	28.12	04900	28.12	04900
24.19	05000	24.19	05000	28.12	05000	28.12	05000
24.19	05100	24.19	05100	28.12	05100	28.12	05100
24.19	05200	24.19	05200	28.12	05200	28.12	05200
24.19	05300	24.19	05300	28.12	05300	28.12	05300
24.19	05400	24.19	05400	28.12	05400	28.12	05400
24.19	05500	24.19	05500	28.12	05500	28.12	05500
24.19	05550	24.19	05550				
24.19	05600	24.19	05600	28.12	05600	28.12	05600
24.19	05650	24.19	05650				
24.19	05700	24.19	05700	28.12	05700	28.12	05700
24.19	05800	24.19	05800	28.12	05800	28.12	05800
24.19	05900	24.19	05900	28.12	05900	28.12	05900
24.19	06000	24.19	06000	28.12	06000	28.12	06000
24.19	06100	24.19	06100	28.22	06100	28.22	06100
24.19	06200	24.19	06200	28.22	06200	28.22	06200
24.19	06300	24.19	06300	28.22	06300	28.22	06300
24.19	06400	24.19	06400	28.22	06400	28.22	06400
24.19	06500	24.19	06500	28.22	06500	28.22	06500
24.19	06600	24.19	06600	28.22	06600	28.22	06600
24.19	06700	24.19	06700	28.22	06700	28.22	06700
24.19	06800	24.19	06800	28.22	06800	28.22	06800
24.19	06900	24.19	06900	28.22	06900	28.22	06900
24.19	07000	24.19	07000	28.22	07000	28.22	07000
24.19	07100	24.19	07100	28.22	07100	28.22	07100
24.19	07200	24.19	07200	28.22	07200	28.22	07200
24.19	07300	24.19	07300	28.22	07300	28.22	07300
24.19	07400	24.19	07400	28.22	07400	28.22	07400
24.19	07500	24.19	07500	28.22	07500	28.22	07500
24.19	07550	24.19	07550				
24.19	07600	24.19	07600	28.22	07600	28.22	07600
24.19	07650	24.19	07650				
24.19	07700	24.19	07700	28.22	07700	28.22	07700
24.19	07800	24.19	07800	28.22	07800	28.22	07800
24.19	07900	24.19	07900	28.22	07900	28.22	07900
24.19	08000	24.19	08000	28.22	08000	28.22	08000
27.81	08100	27.81	08100	31.58	08100	31.58	08100

P	●	●	○	○
M			●	●
K	●	●		
N			○	○
S			○	○
H				
O			○	○

→ v. Page 128+132

Ø DC_{h7} for Type UNI / Ø DC_{m7} for Type VA

High Performance Drill, DIN 6537

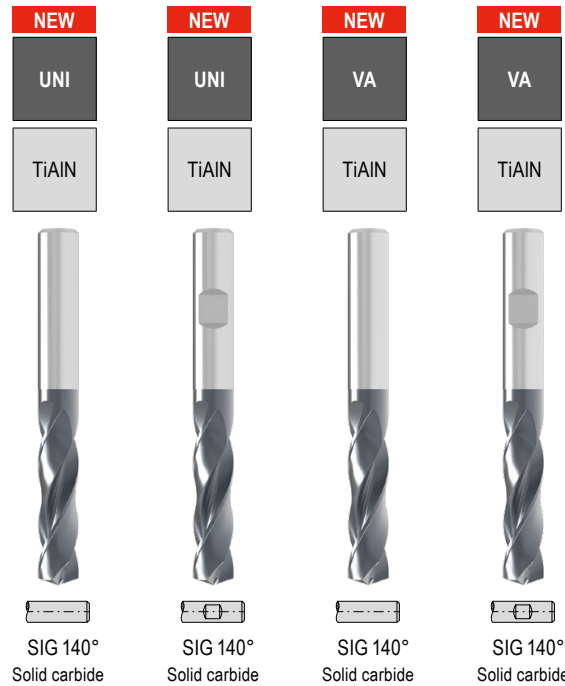
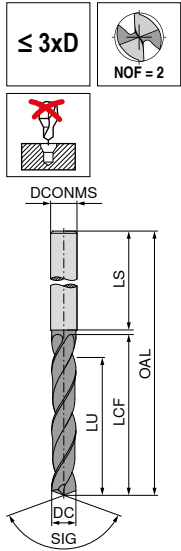

DC _{m7/h7} mm	DCONMS _{h6} mm	OAL mm	LCF mm	LU mm	LS mm
8.20	10	89	47	34.7	40
8.30	10	89	47	34.5	40
8.40	10	89	47	34.4	40
8.50	10	89	47	34.2	40
8.60	10	89	47	34.1	40
8.70	10	89	47	33.9	40
8.80	10	89	47	33.8	40
8.90	10	89	47	33.6	40
9.00	10	89	47	33.5	40
9.10	10	89	47	33.3	40
9.20	10	89	47	33.2	40
9.30	10	89	47	33.0	40
9.40	10	89	47	32.9	40
9.50	10	89	47	32.7	40
9.60	10	89	47	32.6	40
9.70	10	89	47	32.4	40
9.80	10	89	47	32.3	40
9.90	10	89	47	32.1	40
10.00	10	89	47	32.0	40
10.10	12	102	55	39.8	45
10.20	12	102	55	39.7	45
10.30	12	102	55	39.5	45
10.40	12	102	55	39.4	45
10.50	12	102	55	39.2	45
10.60	12	102	55	39.1	45
10.70	12	102	55	38.9	45
10.80	12	102	55	38.8	45
10.90	12	102	55	38.6	45
11.00	12	102	55	38.5	45
11.10	12	102	55	38.3	45
11.20	12	102	55	38.2	45
11.30	12	102	55	38.0	45
11.40	12	102	55	37.9	45
11.50	12	102	55	37.7	45
11.60	12	102	55	37.6	45
11.70	12	102	55	37.4	45
11.80	12	102	55	37.3	45
11.90	12	102	55	37.1	45
12.00	12	102	55	37.0	45

11 706 ...		11 707 ...		11 711 ...		11 712 ...	
£		£		£		£	
T1/9C		T1/9C		T1/9C		T1/9C	
27.81	08200	27.81	08200	31.58	08200	31.58	08200
27.81	08300	27.81	08300	31.58	08300	31.58	08300
27.81	08400	27.81	08400	31.58	08400	31.58	08400
27.81	08500	27.81	08500	31.58	08500	31.58	08500
27.81	08600	27.81	08600	31.58	08600	31.58	08600
27.81	08700	27.81	08700	31.58	08700	31.58	08700
27.81	08800	27.81	08800	31.58	08800	31.58	08800
27.81	08900	27.81	08900	31.58	08900	31.58	08900
27.81	09000	27.81	09000	31.58	09000	31.58	09000
27.81	09100	27.81	09100	31.58	09100	31.58	09100
27.81	09200	27.81	09200	31.58	09200	31.58	09200
27.81	09300	27.81	09300	31.58	09300	31.58	09300
27.81	09400	27.81	09400	31.58	09400	31.58	09400
27.81	09500	27.81	09500	31.58	09500	31.58	09500
27.81	09600	27.81	09600	31.58	09600	31.58	09600
27.81	09700	27.81	09700	31.58	09700	31.58	09700
27.81	09800	27.81	09800	31.58	09800	31.58	09800
27.81	09900	27.81	09900	31.58	09900	31.58	09900
27.81	10000	27.81	10000	31.58	10000	31.58	10000
42.33	10100	42.33	10100	47.64	10100	47.64	10100
42.33	10200	42.33	10200	47.64	10200	47.64	10200
42.33	10300	42.33	10300	47.64	10300	47.64	10300
42.33	10400	42.33	10400	47.64	10400	47.64	10400
42.33	10500	42.33	10500	47.64	10500	47.64	10500
42.33	10600	42.33	10600	47.64	10600	47.64	10600
42.33	10700	42.33	10700	47.64	10700	47.64	10700
42.33	10800	42.33	10800	47.64	10800	47.64	10800
42.33	10900	42.33	10900	47.64	10900	47.64	10900
42.33	11000	42.33	11000	47.64	11000	47.64	11000
42.33	11100	42.33	11100	47.64	11100	47.64	11100
42.33	11200	42.33	11200	47.64	11200	47.64	11200
42.33	11300	42.33	11300	47.64	11300	47.64	11300
42.33	11400	42.33	11400	47.64	11400	47.64	11400
42.33	11500	42.33	11500	47.64	11500	47.64	11500
42.33	11600	42.33	11600	47.64	11600	47.64	11600
42.33	11700	42.33	11700	47.64	11700	47.64	11700
42.33	11800	42.33	11800	47.64	11800	47.64	11800
42.33	11900	42.33	11900	47.64	11900	47.64	11900
42.33	12000	42.33	12000	47.64	12000	47.64	12000

P	●	●	○	○
M			●	●
K	●	●		
N			○	○
S			○	○
H				
O			○	○

→ v. Page 128+132

Ø DC_{h7} for Type UNI / Ø DC_{m7} for Type VA

High Performance Drill, DIN 6537

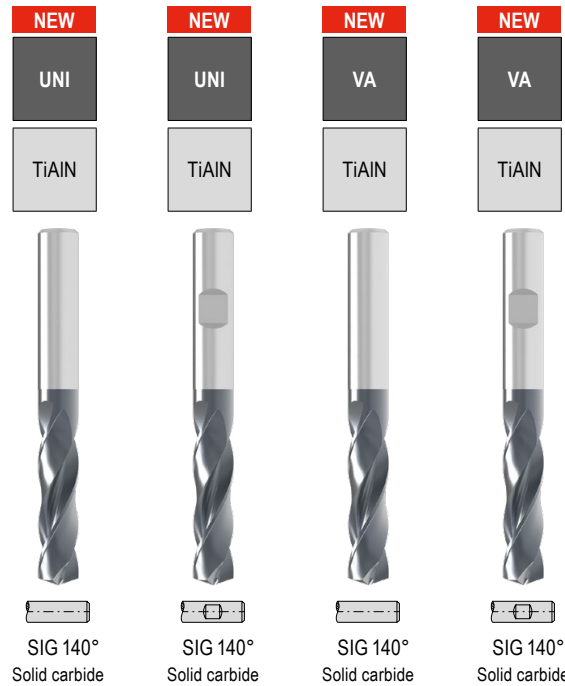
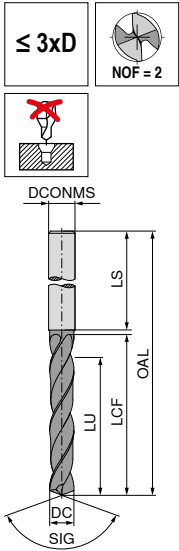

DC _{m7/h7} mm	DCONMS _{h6} mm	OAL mm	LCF mm	LU mm	LS mm	11 706 ...		11 707 ...		11 711 ...		11 712 ...	
						£	12200	£	12200	£	12200	£	12200
12.20	14	107	60	41.7	45	56.84	12200	56.84	12200	63.82	12200	63.82	12200
12.50	14	107	60	41.2	45	56.84	12500	56.84	12500	63.82	12500	63.82	12500
12.70	14	107	60	40.9	45	62.51	12700	62.51	12700	63.82	12700	63.82	12700
12.80	14	107	60	40.8	45	56.84	12800	56.84	12800	63.82	12800	63.82	12800
13.00	14	107	60	40.5	45	56.84	13000	56.84	13000	63.82	13000	63.82	13000
13.10	14	107	60	40.3	45	56.84	13100	56.84	13100	63.82	13100	63.82	13100
13.50	14	107	60	39.7	45	56.84	13500	56.84	13500	63.82	13500	63.82	13500
13.70	14	107	60	39.4	45					63.82	13700	63.82	13700
13.80	14	107	60	39.3	45	56.84	13800	56.84	13800	63.82	13800	63.82	13800
14.00	14	107	60	39.0	45	56.84	14000	56.84	14000	63.82	14000	63.82	14000
14.20	16	115	65	43.7	48	72.57	14200	72.57	14200	82.95	14200	82.95	14200
14.40	16	115	65	43.4	48	72.57	14400	72.57	14400	82.95	14400	82.95	14400
14.50	16	115	65	43.2	48	72.57	14500	72.57	14500	82.95	14500	82.95	14500
14.70	16	115	65	42.9	48					82.95	14700	82.95	14700
14.80	16	115	65	42.8	48	72.57	14800	72.57	14800	82.95	14800	82.95	14800
15.00	16	115	65	42.5	48	72.57	15000	72.57	15000	82.95	15000	82.95	15000
15.10	16	115	65	42.3	48	72.57	15100	72.57	15100	82.95	15100	82.95	15100
15.20	16	115	65	42.2	48	72.57	15200	72.57	15200	82.95	15200	82.95	15200
15.50	16	115	65	41.7	48	72.57	15500	72.57	15500	82.95	15500	82.95	15500
15.70	16	115	65	41.4	48					82.95	15700	82.95	15700
15.80	16	115	65	41.3	48	72.57	15800	72.57	15800	82.95	15800	82.95	15800
16.00	16	115	65	41.0	48	72.57	16000	72.57	16000	82.95	16000	82.95	16000
16.50	18	123	73	48.2	48	124.57	16500	124.57	16500	140.61	16500	140.61	16500
17.00	18	123	73	47.5	48	124.57	17000	124.57	17000	140.61	17000	140.61	17000
17.50	18	123	73	46.7	48	124.57	17500	124.57	17500	140.61	17500	140.61	17500
18.00	18	123	73	46.0	48	124.57	18000	124.57	18000	140.61	18000	140.61	18000
18.50	20	131	79	51.2	50	136.66	18500	136.66	18500	153.84	18500	153.84	18500
18.90	20	131	79	50.6	50	136.66	18900	136.66	18900	153.84	18900	153.84	18900
19.00	20	131	79	50.5	50	136.66	19000	136.66	19000	153.84	19000	153.84	19000
19.50	20	131	79	49.7	50	136.66	19500	136.66	19500	153.84	19500	153.84	19500
20.00	20	131	79	49.0	50	136.66	20000	136.66	20000	153.84	20000	153.84	20000

P	●	●	○	○
M			●	●
K	●	●		
N			○	○
S			○	○
H				
O			○	○

→ v_c Page 128+132

Ø DC_{h7} for Type UNI / Ø DC_{m7} for Type VA

WTX – High Performance Drill, factory standard

- ▲ Special cutting edge geometry
 - ▲ Special flute geometry
 - ▲ Optimised core thickness
- ▲ 46 to 70 HRC

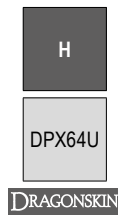
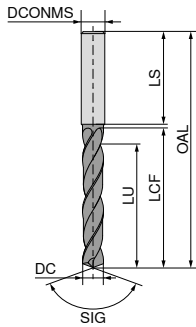
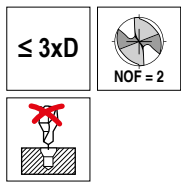

SIG 140°
Solid carbide

10 777 ...

DC _{h7} mm	DCONMS _{h6} mm	OAL mm	LCF mm	LU mm	LS mm	£ T4	
2.55	4	55	20	16.1	28	63.16	02550
2.60	4	55	20	16.1	28	63.16	02600
2.70	4	55	20	15.9	28	63.16	02700
2.80	4	55	20	15.8	28	63.16	02800
2.90	4	55	20	15.6	28	63.16	02900
3.00	6	62	20	15.5	36	91.08	03000
3.10	6	62	20	15.3	36	91.08	03100
3.20	6	62	20	15.2	36	91.08	03200
3.30	6	62	20	15.0	36	91.08	03300
3.40	6	62	20	14.9	36	91.08	03400
3.50	6	62	20	14.7	36	91.08	03500
3.60	6	62	20	14.6	36	91.08	03600
3.70	6	62	20	14.4	36	91.08	03700
3.80	6	66	24	18.3	36	91.08	03800
3.90	6	66	24	18.1	36	91.08	03900
4.00	6	66	24	18.0	36	91.08	04000
4.10	6	66	24	17.8	36	91.08	04100
4.20	6	66	24	17.7	36	91.08	04200
4.30	6	66	24	17.5	36	91.08	04300
4.40	6	66	24	17.4	36	91.08	04400
4.50	6	66	24	17.2	36	91.08	04500
4.60	6	66	24	17.1	36	91.08	04600
4.70	6	66	24	16.9	36	91.08	04700
4.80	6	66	28	20.8	36	91.08	04800
4.90	6	66	28	20.6	36	91.08	04900
5.00	6	66	28	20.5	36	91.08	05000
5.10	6	66	28	20.3	36	91.08	05100
5.20	6	66	28	20.2	36	91.08	05200
5.30	6	66	28	20.0	36	91.08	05300
5.40	6	66	28	19.9	36	91.08	05400
5.50	6	66	28	19.7	36	91.08	05500
5.60	6	66	28	19.6	36	91.08	05600
5.70	6	66	28	19.4	36	91.08	05700
5.80	6	66	28	19.3	36	91.08	05800
5.90	6	66	28	19.1	36	91.08	05900
6.00	6	66	28	19.0	36	91.08	06000
6.10	8	79	34	24.8	36	118.36	06100
6.20	8	79	34	24.7	36	118.36	06200
6.30	8	79	34	24.5	36	118.36	06300
6.40	8	79	34	24.4	36	118.36	06400
6.50	8	79	34	24.2	36	118.36	06500
6.60	8	79	34	24.1	36	118.36	06600
6.70	8	79	34	23.9	36	118.36	06700
6.80	8	79	34	23.8	36	118.36	06800
6.90	8	79	34	23.6	36	118.36	06900
7.00	8	79	34	23.5	36	118.36	07000
7.10	8	79	41	30.3	36	118.36	07100
7.20	8	79	41	30.2	36	118.36	07200
7.30	8	79	41	30.0	36	118.36	07300
7.40	8	79	41	29.9	36	118.36	07400
7.50	8	79	41	29.7	36	118.36	07500

10 777 ...

DC _{h7} mm	DCONMS _{h6} mm	OAL mm	LCF mm	LU mm	LS mm	£ T4	
7.60	8	79	41	29.6	36	118.36	07600
7.70	8	79	41	29.4	36	118.36	07700
7.80	8	79	41	29.3	36	118.36	07800
7.90	8	79	41	29.1	36	118.36	07900
8.00	8	79	41	29.0	36	118.36	08000
8.10	10	89	47	34.8	40	133.78	08100
8.20	10	89	47	34.7	40	133.78	08200
8.30	10	89	47	34.5	40	133.78	08300
8.40	10	89	47	34.4	40	133.78	08400
8.50	10	89	47	34.2	40	133.78	08500
8.60	10	89	47	34.1	40	133.78	08600
8.70	10	89	47	33.9	40	133.78	08700
8.80	10	89	47	33.8	40	133.78	08800
8.90	10	89	47	33.6	40	133.78	08900
9.00	10	89	47	33.5	40	133.78	09000
9.10	10	89	47	33.3	40	133.78	09100
9.20	10	89	47	33.2	40	133.78	09200
9.30	10	89	47	33.0	40	133.78	09300
9.40	10	89	47	32.9	40	133.78	09400
9.50	10	89	47	32.7	40	133.78	09500
9.60	10	89	47	32.6	40	133.78	09600
9.70	10	89	47	32.4	40	133.78	09700
9.80	10	89	47	32.3	40	133.78	09800
9.90	10	89	47	32.1	40	133.78	09900
10.00	10	89	47	32.0	40	133.78	10000
10.10	12	102	55	39.8	45	173.73	10100
10.20	12	102	55	39.7	45	173.73	10200
10.30	12	102	55	39.5	45	173.73	10300
10.40	12	102	55	39.4	45	173.73	10400
10.50	12	102	55	39.2	45	173.73	10500
10.60	12	102	55	39.1	45	173.73	10600
10.70	12	102	55	38.9	45	173.73	10700
10.80	12	102	55	38.8	45	173.73	10800
10.90	12	102	55	38.6	45	173.73	10900
11.00	12	102	55	38.5	45	173.73	11000
11.10	12	102	55	38.3	45	173.73	11100
11.20	12	102	55	38.2	45	173.73	11200
11.30	12	102	55	38.0	45	173.73	11300
11.40	12	102	55	37.9	45	173.73	11400
11.50	12	102	55	37.7	45	173.73	11500
11.60	12	102	55	37.6	45	173.73	11600
11.70	12	102	55	37.4	45	173.73	11700
11.80	12	102	55	37.3	45	173.73	11800
11.90	12	102	55	37.1	45	173.73	11900
12.00	12	102	55	37.0	45	173.73	12000
12.10	14	107	60	41.8	45	205.28	12100
12.20	14	107	60	41.7	45	205.28	12200
12.30	14	107	60	41.5	45	205.28	12300
12.40	14	107	60	41.4	45	205.28	12400
12.50	14	107	60	41.2	45	205.28	12500
12.60	14	107	60	41.1	45	205.28	12600
12.70	14	107	60	40.9	45	205.28	12700
12.80	14	107	60	40.8	45	205.28	12800
12.90	14	107	60	40.6	45	205.28	12900
13.00	14	107	60	40.5	45	205.28	13000
13.10	14	107	60	40.3	45	205.28	13100
13.20	14	107	60	40.2	45	205.28	13200
13.30	14	107	60	40.0	45	205.28	13300
13.40	14	107	60	39.9	45	205.28	13400
13.50	14	107	60	39.7	45	205.28	13500
13.60	14	107	60	39.6	45	205.28	13600
13.70	14	107	60	39.4	45	205.28	13700
13.80	14	107	60	39.3	45	205.28	13800
13.90	14	107	60	39.1	45	205.28	13900
14.00	14	107	60	39.0	45	205.28	14000

P	○
K	●
S	●
H.1.1	●
H.1.2	●
H.1.3	●
H.1.4	●

→ v_c Page 119

Twist drill similar to DIN 1897

- ▲ Helix angle 30°
- ▲ Shank Ø h7

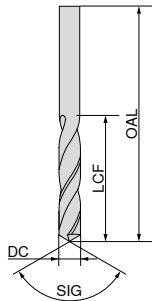

SIG 118°
Solid carbide

DC _{h7} mm	OAL mm	LCF mm	£ T3	
0.5	20	3.0	7.22	005
0.6	21	3.5	7.59	006
0.7	23	4.5	7.59	007
0.8	24	5.0	7.59	008
0.9	25	5.5	7.59	009
1.0	26	6.0	7.59	010
1.2	30	8.0	7.59	012
1.3	30	8.0	7.59	013
1.4	32	9.0	7.59	014
1.5	32	9.0	7.59	015
1.6	34	10.0	7.59	016
1.7	34	10.0	7.59	017
1.8	36	11.0	7.59	018
1.9	36	11.0	7.59	019
2.0	38	12.0	10.18	020
2.1	38	12.0	10.50	021
2.2	40	13.0	10.50	022
2.3	40	13.0	10.50	023
2.4	43	14.0	10.50	024
2.5	43	14.0	11.78	025
2.6	43	14.0	11.78	026
2.7	46	16.0	12.37	027
2.8	46	16.0	12.37	028
2.9	46	16.0	12.37	029
3.0	46	16.0	13.23	030
3.1	49	18.0	13.23	031
3.2	49	18.0	13.23	032
3.3	49	18.0	15.48	033
3.4	52	20.0	15.48	034
3.5	52	20.0	16.69	035
3.6	52	20.0	16.69	036
3.7	52	20.0	16.69	037
3.8	55	22.0	17.21	038
3.9	55	22.0	17.21	039
4.0	55	22.0	19.85	040
4.1	55	22.0	19.85	041
4.2	55	22.0	21.61	042
4.3	58	24.0	21.61	043
4.4	58	24.0	21.61	044
4.5	58	24.0	23.38	045
4.6	58	24.0	23.38	046
4.7	58	24.0	23.38	047
4.8	62	26.0	23.38	048
4.9	62	26.0	23.38	049
5.0	62	26.0	26.19	050
5.1	62	26.0	26.19	051
5.2	62	26.0	26.99	052
5.3	62	26.0	26.99	053
5.4	66	28.0	26.99	054
5.5	66	28.0	30.41	055
5.6	66	28.0	30.41	056
5.7	66	28.0	30.41	057

10 700 ...

DC _{h7} mm	OAL mm	LCF mm	£ T3	
5.8	66	28.0	30.41	058
5.9	66	28.0	30.41	059
6.0	66	28.0	33.75	060
6.1	70	31.0	34.77	061
6.2	70	31.0	34.77	062
6.3	70	31.0	34.77	063
6.4	70	31.0	34.77	064
6.5	70	31.0	37.63	065
6.6	70	31.0	41.46	066
6.7	70	31.0	41.46	067
6.8	74	34.0	41.46	068
6.9	74	34.0	41.46	069
7.0	74	34.0	41.46	070
7.1	74	34.0	41.46	071
7.2	74	34.0	41.46	072
7.3	74	34.0	41.46	073
7.4	74	34.0	41.46	074
7.5	74	34.0	47.97	075
7.6	79	37.0	47.97	076
7.7	79	37.0	47.97	077
7.8	79	37.0	47.97	078
7.9	79	37.0	47.97	079
8.0	79	37.0	49.26	080
8.1	79	37.0	54.01	081
8.2	79	37.0	54.01	082
8.3	79	37.0	54.01	083
8.4	79	37.0	54.01	084
8.5	79	37.0	55.93	085
8.6	84	40.0	57.03	086
8.7	84	40.0	57.03	087
8.8	84	40.0	62.37	088
8.9	84	40.0	62.37	089
9.0	84	40.0	62.37	090
9.1	84	40.0	62.37	091
9.2	84	40.0	62.37	092
9.3	84	40.0	62.37	093
9.4	84	40.0	62.37	094
9.5	84	40.0	67.14	095
9.6	89	43.0	67.14	096
9.7	89	43.0	67.14	097
9.8	89	43.0	67.14	098
9.9	89	43.0	67.14	099
10.0	89	43.0	74.52	100
10.2	89	43.0	79.46	102
10.5	89	43.0	79.46	105
10.8	95	47.0	79.46	108
11.0	95	47.0	88.54	110
11.2	95	47.0	96.99	112
11.5	95	47.0	98.34	115
11.8	95	47.0	98.34	118
12.0	102	51.0	110.32	120
12.5	102	51.0	120.36	125
13.0	102	51.0	134.87	130
13.5	107	54.0	153.48	135
14.0	107	54.0	166.60	140
14.5	111	56.0	178.25	145
15.0	111	56.0	193.30	150
15.5	115	58.0	208.65	155
16.0	115	58.0	219.92	160
18.0	123	62.0	295.10	180
20.0	131	66.0	395.40	200

P	○
M	○
K	●
N	●
S	○
H	○
O	○

→ v. Page 134

WTX – High Performance Drill, DIN 6537

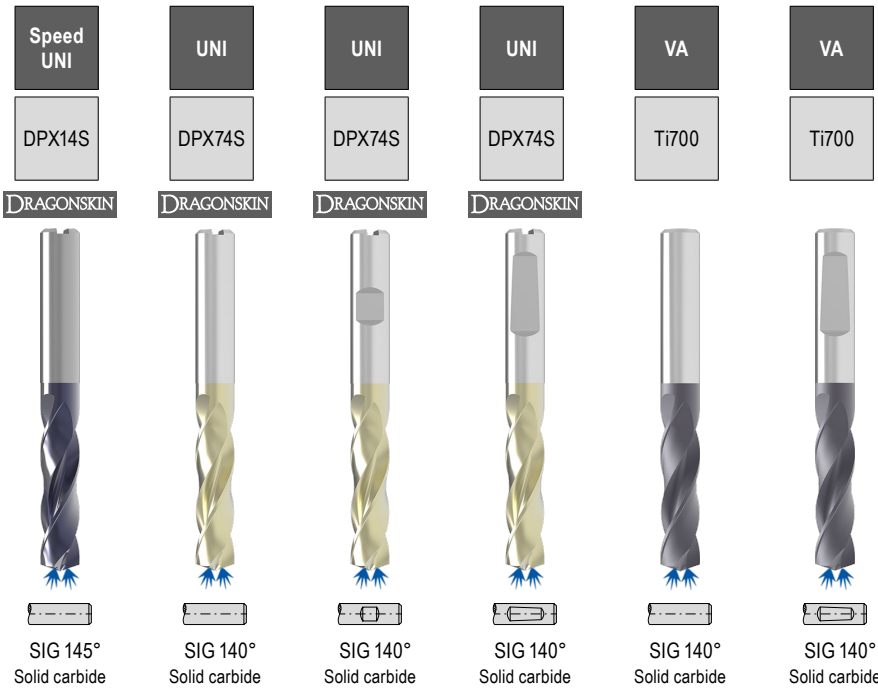
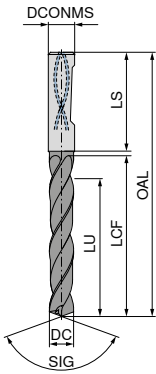
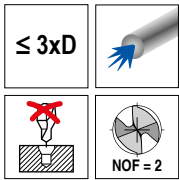

DC _{mT7} mm	DCONMS _{h6} mm	OAL mm	LCF mm	LU mm	LS mm	10 781 ...		11 780 ...		11 781 ...		11 779 ...		10 734 ...		10 733 ...	
						£ T4	03000	£ T7	03000	£ T7	03000	£ T7	03000	£ T5	030	£ T5	030
3.00	6	62	20	14	36	116.32	03000	54.81	03100	54.81	03000	54.81	03000	106.46	030	106.46	030
3.10	6	62	20	14	36	116.32	03100	54.81	03100	54.81	03100	54.81	03100	106.46	031	106.46	031
3.15	6	62	20	14	36			54.81	03150	54.81	03150	54.81	03150	106.46	831		
3.20	6	62	20	14	36	116.32	03200	54.81	03200	54.81	03200	54.81	03200	106.46	032	106.46	032
3.22	6	62	20	14	36			54.81	03220	54.81	03220	54.81	03220	106.46	832		
3.25	6	62	20	14	36			54.81	03250	54.81	03250	54.81	03250	106.46	890		
3.30	6	62	20	14	36	116.32	03300	54.81	03300	54.81	03300	54.81	03300	106.46	033	106.46	033
3.40	6	62	20	14	36	116.32	03400	54.81	03400	54.81	03400	54.81	03400	106.46	034	106.46	034
3.50	6	62	20	14	36	116.32	03500	54.81	03500	54.81	03500	54.81	03500	106.46	035	106.46	035
3.60	6	62	20	14	36	116.32	03600	54.81	03600	54.81	03600	54.81	03600	106.46	036	106.46	036
3.70	6	62	20	14	36	116.32	03700	54.81	03700	54.81	03700	54.81	03700	106.46	037	106.46	037
3.80	6	66	24	17	36	116.32	03800	54.81	03800	54.81	03800	54.81	03800	106.46	038	106.46	038
3.85	6	66	24	17	36			54.81	03850	54.81	03850	54.81	03850	106.46	838		
3.90	6	66	24	17	36	116.32	03900	54.81	03900	54.81	03900	54.81	03900	106.46	039	106.46	039
4.00	6	66	24	17	36	116.32	04000	54.81	04000	54.81	04000	54.81	04000	106.46	040	106.46	040
4.10	6	66	24	17	36	116.32	04100	54.81	04100	54.81	04100	54.81	04100	106.46	041	106.46	041
4.20	6	66	24	17	36	116.32	04200	54.81	04200	54.81	04200	54.81	04200	106.46	042	106.46	042
4.25	6	66	24	17	36			54.81	04250	54.81	04250	54.81	04250				
4.30	6	66	24	17	36	116.32	04300	54.81	04300	54.81	04300	54.81	04300	106.46	043	106.46	043
4.35	6	66	24	17	36			54.81	04350	54.81	04350	54.81	04350	106.46	843		
4.40	6	66	24	17	36	116.32	04400	54.81	04400	54.81	04400	54.81	04400	106.46	044	106.46	044
4.45	6	66	24	17	36			54.81	04450	54.81	04450	54.81	04450	106.46	844		
4.50	6	66	24	17	36	116.32	04500	54.81	04500	54.81	04500	54.81	04500	106.46	045	106.46	045
4.60	6	66	24	17	36	116.32	04600	54.81	04600	54.81	04600	54.81	04600	106.46	046	106.46	046
4.65	6	66	24	17	36	116.32	04650	54.81	04650	54.81	04650	54.81	04650	106.46	900	106.46	900
4.70	6	66	24	17	36	116.32	04700	54.81	04700	54.81	04700	54.81	04700	106.46	047	106.46	047
4.80	6	66	28	20	36	116.32	04800	54.81	04800	54.81	04800	54.81	04800	106.46	048	106.46	048
4.90	6	66	28	20	36	116.32	04900	54.81	04900	54.81	04900	54.81	04900	106.46	049	106.46	049
4.95	6	66	28	20	36			54.81	04950	54.81	04950	54.81	04950				
5.00	6	66	28	20	36	116.32	05000	54.81	05000	54.81	05000	54.81	05000	106.46	050	106.46	050
5.05	6	66	28	20	36			54.81	05050	54.81	05050	54.81	05050				
5.10	6	66	28	20	36	116.32	05100	54.81	05100	54.81	05100	54.81	05100	106.46	051	106.46	051
5.20	6	66	28	20	36	116.32	05200	54.81	05200	54.81	05200	54.81	05200	106.46	052	106.46	052
5.30	6	66	28	20	36	116.32	05300	54.81	05300	54.81	05300	54.81	05300	106.46	053	106.46	053
5.40	6	66	28	20	36	116.32	05400	54.81	05400	54.81	05400	54.81	05400	106.46	054	106.46	054
5.50	6	66	28	20	36	116.32	05500	54.81	05500	54.81	05500	54.81	05500	106.46	055	106.46	055
5.55	6	66	28	20	36	116.32	05550	54.81	05550	54.81	05550	54.81	05550	106.46	902	106.46	902
5.60	6	66	28	20	36	116.32	05600	54.81	05600	54.81	05600	54.81	05600	106.46	056	106.46	056
5.70	6	66	28	20	36	116.32	05700	54.81	05700	54.81	05700	54.81	05700	106.46	057	106.46	057
5.75	6	66	28	20	36			54.81	05750	54.81	05750	54.81	05750	106.46	916		
5.80	6	66	28	20	36	116.32	05800	54.81	05800	54.81	05800	54.81	05800	106.46	058	106.46	058
5.90	6	66	28	20	36	116.32	05900	54.81	05900	54.81	05900	54.81	05900	106.46	059	106.46	059

P	•	•	•	•	○	○
M	•				•	•
K	•	•	•	•	○	○
N					○	○
S					•	•
H		○	○	○		
O						

WTX – High Performance Drill, DIN 6537

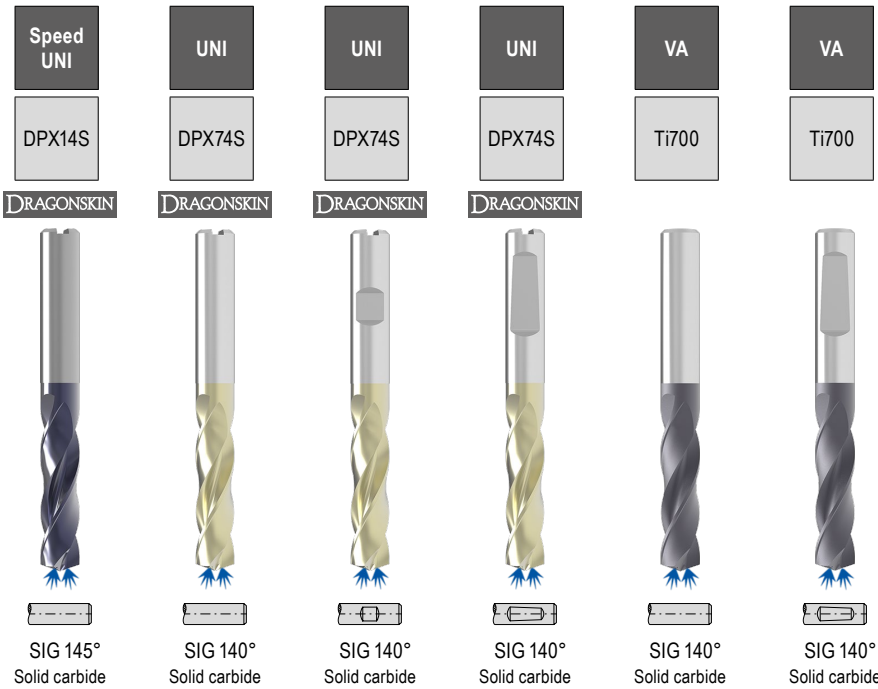
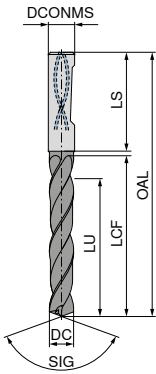
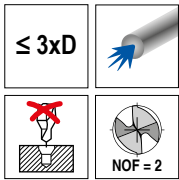

DC _{mT7} mm	DCONMS _{h6} mm	OAL mm	LCF mm	LU mm	LS mm	10 781 ... £ T4	11 780 ... £ T7	11 781 ... £ T7	11 779 ... £ T7	10 734 ... £ T5	10 733 ... £ T5
5.95	6	66	28	20	36		54.81 05950	54.81 05950	54.81 05950	106.46 959	
6.00	6	66	28	20	36	116.32 06000	54.81 06000	54.81 06000	54.81 06000	106.46 060	106.46 060
6.10	8	79	34	24	36	142.16 06100	71.59 06100	71.59 06100	71.59 06100	131.41 061	131.41 061
6.20	8	79	34	24	36	142.16 06200	71.59 06200	71.59 06200	71.59 06200	131.41 062	131.41 062
6.30	8	79	34	24	36	142.16 06300	71.59 06300	71.59 06300	71.59 06300	131.41 063	131.41 063
6.40	8	79	34	24	36	142.16 06400	71.59 06400	71.59 06400	71.59 06400	131.41 064	131.41 064
6.50	8	79	34	24	36	142.16 06500	71.59 06500	71.59 06500	71.59 06500	131.41 065	131.41 065
6.60	8	79	34	24	36	142.16 06600	71.59 06600	71.59 06600	71.59 06600	131.41 066	131.41 066
6.70	8	79	34	24	36	142.16 06700	71.59 06700	71.59 06700	71.59 06700	131.41 067	131.41 067
6.80	8	79	34	24	36	142.16 06800	71.59 06800	71.59 06800	71.59 06800	131.41 068	131.41 068
6.90	8	79	34	24	36	142.16 06900	71.59 06900	71.59 06900	71.59 06900	131.41 069	131.41 069
7.00	8	79	34	24	36	142.16 07000	71.59 07000	71.59 07000	71.59 07000	131.41 070	131.41 070
7.10	8	79	41	29	36	142.16 07100	71.59 07100	71.59 07100	71.59 07100	131.41 071	131.41 071
7.20	8	79	41	29	36	142.16 07200	71.59 07200	71.59 07200	71.59 07200	131.41 072	131.41 072
7.30	8	79	41	29	36	142.16 07300	71.59 07300	71.59 07300	71.59 07300	131.41 073	131.41 073
7.40	8	79	41	29	36	142.16 07400	71.59 07400	71.59 07400	71.59 07400	131.41 074	131.41 074
7.45	8	79	41	29	36		71.59 07450	71.59 07450	71.59 07450	131.41 924	
7.50	8	79	41	29	36	142.16 07500	71.59 07500	71.59 07500	71.59 07500	131.41 075	131.41 075
7.60	8	79	41	29	36	142.16 07600	71.59 07600	71.59 07600	71.59 07600	131.41 076	131.41 076
7.70	8	79	41	29	36	142.16 07700	71.59 07700	71.59 07700	71.59 07700	131.41 077	131.41 077
7.80	8	79	41	29	36	142.16 07800	71.59 07800	71.59 07800	71.59 07800	131.41 078	131.41 078
7.90	8	79	41	29	36	142.16 07900	71.59 07900	71.59 07900	71.59 07900	131.41 079	131.41 079
8.00	8	79	41	29	36	142.16 08000	71.59 08000	71.59 08000	71.59 08000	130.55 080	130.55 080
8.10	10	89	47	35	40	196.06 08100	81.80 08100	81.80 08100	81.80 08100	131.41 081	131.41 081
8.20	10	89	47	35	40	196.06 08200	81.80 08200	81.80 08200	81.80 08200	131.41 082	131.41 082
8.30	10	89	47	35	40	196.06 08300	81.80 08300	81.80 08300	81.80 08300	131.41 083	131.41 083
8.40	10	89	47	35	40	196.06 08400	81.80 08400	81.80 08400	81.80 08400	131.41 084	131.41 084
8.50	10	89	47	35	40	196.06 08500	81.80 08500	81.80 08500	81.80 08500	131.41 085	131.41 085
8.60	10	89	47	35	40	196.06 08600	81.80 08600	81.80 08600	81.80 08600	131.41 086	131.41 086
8.70	10	89	47	35	40	196.06 08700	81.80 08700	81.80 08700	81.80 08700	131.41 087	131.41 087
8.80	10	89	47	35	40	196.06 08800	81.80 08800	81.80 08800	81.80 08800	131.41 088	131.41 088
8.90	10	89	47	35	40	196.06 08900	81.80 08900	81.80 08900	81.80 08900	131.41 089	131.41 089
9.00	10	89	47	35	40	196.06 09000	81.80 09000	81.80 09000	81.80 09000	131.41 090	131.41 090
9.10	10	89	47	35	40	196.06 09100	81.80 09100	81.80 09100	81.80 09100	131.41 091	131.41 091
9.20	10	89	47	35	40	196.06 09200	81.80 09200	81.80 09200	81.80 09200	151.82 092	151.82 092
9.30	10	89	47	35	40	196.06 09300	81.80 09300	81.80 09300	81.80 09300	151.82 093	151.82 093
9.35	10	89	47	35	40		81.80 09350	81.80 09350	81.80 09350	151.82 930	
9.40	10	89	47	35	40	196.06 09400	81.80 09400	81.80 09400	81.80 09400	151.82 094	151.82 094
9.45	10	89	47	35	40		81.80 09450	81.80 09450	81.80 09450	151.82 994	
9.50	10	89	47	35	40	196.06 09500	81.80 09500	81.80 09500	81.80 09500	151.82 095	151.82 095
9.60	10	89	47	35	40	196.06 09600	81.80 09600	81.80 09600	81.80 09600	151.82 096	151.82 096
9.70	10	89	47	35	40	196.06 09700	81.80 09700	81.80 09700	81.80 09700	151.82 097	151.82 097

P	●	●	●	●	○	○
M	●	●	●	●	●	●
K	●	●	●	●	○	○
N					○	○
S					●	●
H		○	○	○		
O						

WTX – High Performance Drill, DIN 6537

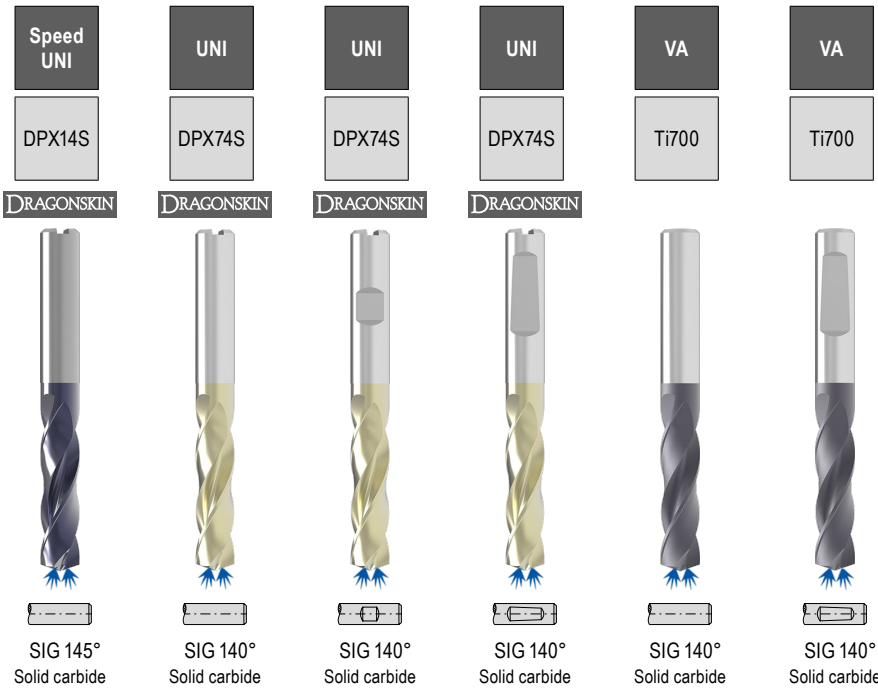
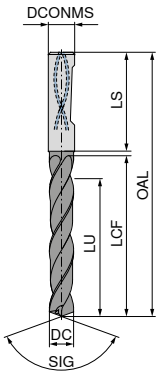
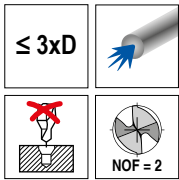

DC _{mT7} mm	DCONMS _{h6} mm	OAL mm	LCF mm	LU mm	LS mm	10 781 ...		11 780 ...		11 781 ...		11 779 ...		10 734 ...		10 733 ...	
						£ T4	09800	£ T7	09800	£ T7	09800	£ T7	09800	£ T5	098	£ T5	098
9.80	10	89	47	35	40	196.06	09800	81.80	09800	81.80	09800	81.80	09800	151.82	098	151.82	098
9.90	10	89	47	35	40	196.06	09900	81.80	09900	81.80	09900	81.80	09900	151.82	099	151.82	099
10.00	10	89	47	35	40	196.06	10000	81.80	10000	81.80	10000	81.80	10000	151.82	100	151.82	100
10.10	12	102	55	40	45	246.97	10100	114.21	10100	114.21	10100	114.21	10100	210.64	101	210.64	101
10.20	12	102	55	40	45	246.97	10200	114.21	10200	114.21	10200	114.21	10200	210.64	102	210.64	102
10.30	12	102	55	40	45	246.97	10300	114.21	10300	114.21	10300	114.21	10300	210.64	103	210.64	103
10.40	12	102	55	40	45	246.97	10400	114.21	10400	114.21	10400	114.21	10400	210.64	104	210.64	104
10.50	12	102	55	40	45	246.97	10500	114.21	10500	114.21	10500	114.21	10500	210.64	105	210.64	105
10.55	12	102	55	40	45			114.21	10550	114.21	10550	114.21	10550	210.64	932		
10.60	12	102	55	40	45	246.97	10600	114.21	10600	114.21	10600	114.21	10600	210.64	106	210.64	106
10.70	12	102	55	40	45	246.97	10700	114.21	10700	114.21	10700	114.21	10700	210.64	107	210.64	107
10.75	12	102	55	40	45			114.21	10750	114.21	10750	114.21	10750				
10.80	12	102	55	40	45	246.97	10800	114.21	10800	114.21	10800	114.21	10800	210.64	108	210.64	108
10.90	12	102	55	40	45	246.97	10900	114.21	10900	114.21	10900	114.21	10900	210.64	109	210.64	109
11.00	12	102	55	40	45	246.97	11000	114.21	11000	114.21	11000	114.21	11000	210.64	110	210.64	110
11.10	12	102	55	40	45	246.97	11100	114.21	11100	114.21	11100	114.21	11100	210.64	111	210.64	111
11.20	12	102	55	40	45	246.97	11200	114.21	11200	114.21	11200	114.21	11200	210.64	112	210.64	112
11.25	12	102	55	40	45			114.21	11250	114.21	11250	114.21	11250	210.64	912		
11.30	12	102	55	40	45	246.97	11300	114.21	11300	114.21	11300	114.21	11300	210.64	113	210.64	113
11.35	12	102	55	40	45			114.21	11350	114.21	11350	114.21	11350	210.64	913		
11.40	12	102	55	40	45	246.97	11400	114.21	11400	114.21	11400	114.21	11400	210.64	114	210.64	114
11.45	12	102	55	40	45			114.21	11450	114.21	11450	114.21	11450	210.64	914		
11.50	12	102	55	40	45	246.97	11500	114.21	11500	114.21	11500	114.21	11500	210.64	115	210.64	115
11.60	12	102	55	40	45	246.97	11600	114.21	11600	114.21	11600	114.21	11600	210.64	116	210.64	116
11.70	12	102	55	40	45	246.97	11700	114.21	11700	114.21	11700	114.21	11700	210.64	117	210.64	117
11.80	12	102	55	40	45	246.97	11800	114.21	11800	114.21	11800	114.21	11800	210.64	118	210.64	118
11.90	12	102	55	40	45	246.97	11900	114.21	11900	114.21	11900	114.21	11900	210.64	119	210.64	119
12.00	12	102	55	40	45	246.97	12000	114.21	12000	114.21	12000	114.21	12000	210.64	120	210.64	120
12.15	14	107	60	43	45			161.77	12150	161.77	12150	161.77	12150	296.56	921		
12.25	14	107	60	43	45			161.77	12250	161.77	12250	161.77	12250				
12.50	14	107	60	43	45	403.44	12500	161.77	12500	161.77	12500	161.77	12500	296.56	125	296.56	125
12.55	14	107	60	43	45			161.77	12550	161.77	12550	161.77	12550	296.56	925		
12.70	14	107	60	43	45			161.77	12700	161.77	12700	161.77	12700				
12.80	14	107	60	43	45	403.44	12800	161.77	12800	161.77	12800	161.77	12800	296.56	128	296.56	128
12.90	14	107	60	43	45			161.77	12900	161.77	12900	161.77	12900				
13.00	14	107	60	43	45	403.44	13000	161.77	13000	161.77	13000	161.77	13000	296.56	130	296.56	130
13.10	14	107	60	43	45			161.77	13100	161.77	13100	161.77	13100				
13.30	14	107	60	43	45			161.77	13300	161.77	13300	161.77	13300				
13.35	14	107	60	43	45			161.77	13350	161.77	13350	161.77	13350	296.56	933		
13.50	14	107	60	43	45	403.44	13500	161.77	13500	161.77	13500	161.77	13500	296.56	135	296.56	135
13.70	14	107	60	43	45			161.77	13700	161.77	13700	161.77	13700				
13.80	14	107	60	43	45	403.44	13800	161.77	13800	161.77	13800	161.77	13800	296.56	138	296.56	138

P	●	●	●	●	○	○
M	●				●	●
K	●	●	●	●	○	○
N					○	○
S					●	●
H		○	○	○		
O						

WTX – High Performance Drill, DIN 6537

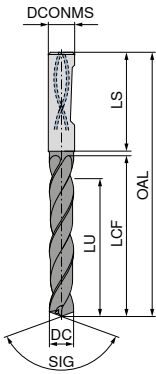
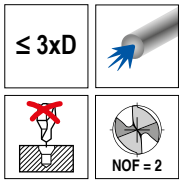

Speed UNI	UNI	UNI	UNI	VA	VA
DPX14S	DPX74S	DPX74S	DPX74S	Ti700	Ti700

DRAGONSKIN DRAGONSKIN DRAGONSKIN DRAGONSKIN

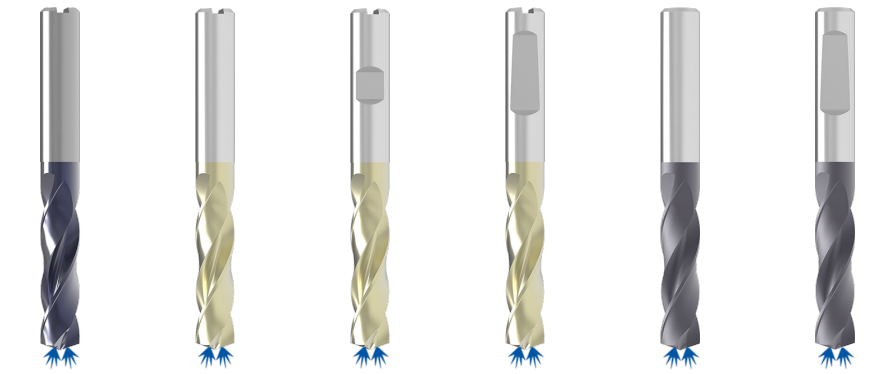

SIG 145° Solid carbide SIG 140° Solid carbide SIG 140° Solid carbide SIG 140° Solid carbide SIG 140° Solid carbide SIG 140° Solid carbide

DC _{mTn7} mm	DCONMS _{h6} mm	OAL mm	LCF mm	LU mm	LS mm	10 781 ... £ T4	11 780 ... £ T7	11 781 ... £ T7	11 779 ... £ T7	10 734 ... £ T5	10 733 ... £ T5				
14.00	14	107	60	43	45	403.44	14000	161.77	14000	161.77	14000	296.56	140	296.56	140
14.20	16	115	65	45	48			190.38	14200	190.38	14200				
14.50	16	115	65	45	48	507.11	14500	190.38	14500	190.38	14500	375.81	145	375.81	145
14.80	16	115	65	45	48	507.11	14800	190.38	14800	190.38	14800	375.81	148	375.81	148
15.00	16	115	65	45	48	507.11	15000	190.38	15000	190.38	15000	375.81	150	375.81	150
15.10	16	115	65	45	48			190.38	15100	190.38	15100				
15.25	16	115	65	45	48			190.38	15250	190.38	15250				
15.30	16	115	65	45	48			190.38	15300	190.38	15300				
15.35	16	115	65	45	48			190.38	15350	190.38	15350	375.81	953		
15.50	16	115	65	45	48	507.11	15500	190.38	15500	190.38	15500	375.81	155	375.81	155
15.60	16	115	65	45	48			190.38	15600	190.38	15600				
15.80	16	115	65	45	48	507.11	15800	190.38	15800	190.38	15800	375.81	158	375.81	158
16.00	16	115	65	45	48	507.11	16000	190.38	16000	190.38	16000	375.81	160	375.81	160
16.05	18	123	73	51	48			308.98	16050	308.98	16050	515.98	960		
16.50	18	123	73	51	48	682.44	16500	308.98	16500	308.98	16500	515.98	165	515.98	165
16.80	18	123	73	51	48	682.44	16800	308.98	16800	308.98	16800	515.98	168	515.98	168
16.90	18	123	73	51	48			308.98	16900	308.98	16900				
17.00	18	123	73	51	48	682.44	17000	308.98	17000	308.98	17000	515.98	170	515.98	170
17.50	18	123	73	51	48	682.44	17500	308.98	17500	308.98	17500	515.98	175	515.98	175
17.60	18	123	73	51	48			308.98	17600	308.98	17600				
17.80	18	123	73	51	48	682.44	17800	308.98	17800	308.98	17800	515.98	178	515.98	178
18.00	18	123	73	51	48	682.44	18000	308.98	18000	308.98	18000	515.98	180	515.98	180
18.50	20	131	79	55	50	831.39	18500	332.78	18500	332.78	18500	640.55	185	640.55	185
18.80	20	131	79	55	50	831.39	18800	332.78	18800	332.78	18800	640.55	188	640.55	188
18.90	20	131	79	55	50			332.78	18900	332.78	18900				
19.00	20	131	79	55	50	831.39	19000	332.78	19000	332.78	19000	640.55	190	640.55	190
19.35	20	131	79	55	50			332.78	19350	332.78	19350	640.55	993		
19.50	20	131	79	55	50	831.39	19500	332.78	19500	332.78	19500	640.55	195	640.55	195
19.60	20	131	79	55	50			332.78	19600	332.78	19600				
19.80	20	131	79	55	50	831.39	19800	332.78	19800	332.78	19800	640.55	198	640.55	198
20.00	20	131	79	55	50	831.39	20000	332.78	20000	332.78	20000	640.55	200	640.55	200
20.50	25	151	93	66	56			734.72	20500	734.72	20500				
21.00	25	151	93	66	56			734.72	21000	734.72	21000				
21.50	25	151	93	66	56			734.72	21500	734.72	21500				
22.00	25	151	93	66	56			734.72	22000	734.72	22000				
22.50	25	153	96	72	56			734.72	22500	734.72	22500				
23.00	25	153	96	72	56			734.72	23000	734.72	23000				
23.50	25	153	96	72	56			734.72	23500	734.72	23500				
24.00	25	153	96	72	56			734.72	24000	734.72	24000				
24.50	25	153	96	75	56			734.72	24500	734.72	24500				
25.00	25	153	96	75	56			734.72	25000	734.72	25000				

P	●	●	●	●	○	○
M	●				●	●
K	●	●	●	●	○	○
N					○	○
S					●	●
H		○	○	○		
O						

→ v_c Page 110-116

Ø DC_{m7} for Type UNI and VA / Ø DC_{h7} for Type Speed UNI

High Performance Drill, DIN 6537

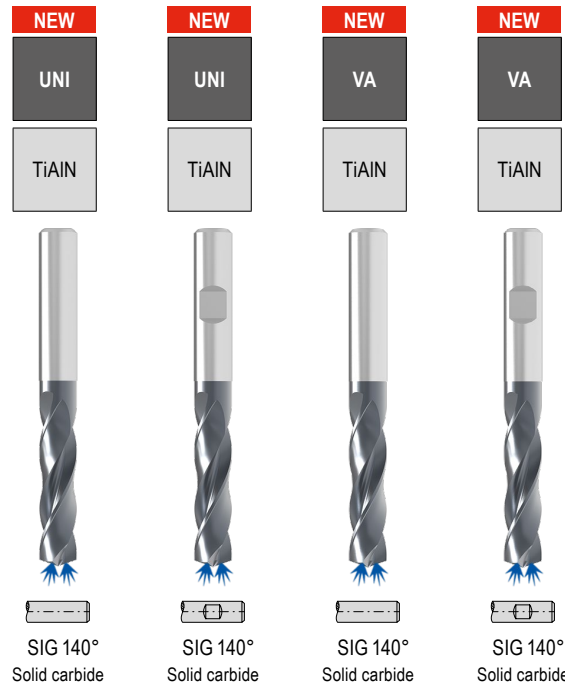
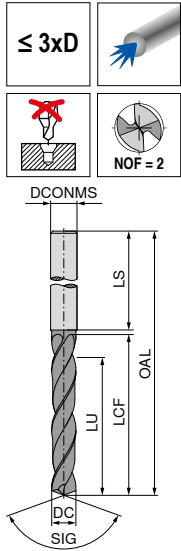

DC _{m7/h7} mm	DCONMS _{h6} mm	OAL mm	LCF mm	LU mm	LS mm
1.00	4	45	7	5.5	28
1.10	4	45	7	5.3	28
1.20	4	45	7	5.2	28
1.30	4	45	7	5.0	28
1.40	4	45	7	4.9	28
1.50	4	55	14	11.7	28
1.60	4	55	14	11.6	28
1.70	4	55	14	11.4	28
1.80	4	55	14	11.3	28
1.90	4	55	14	11.1	28
2.00	4	55	20	17.0	28
2.10	4	55	20	16.8	28
2.20	4	55	20	16.7	28
2.30	4	55	20	16.5	28
2.40	4	55	20	16.4	28
2.50	4	55	20	16.2	28
2.60	4	55	20	16.1	28
2.70	4	55	20	15.9	28
2.80	4	55	20	15.8	28
2.90	4	55	20	15.6	28
3.00	6	62	20	15.5	36
3.10	6	62	20	15.3	36
3.20	6	62	20	15.2	36
3.25	6	62	20	15.1	36
3.30	6	62	20	15.0	36
3.40	6	62	20	14.9	36
3.50	6	62	20	14.7	36
3.60	6	62	20	14.6	36
3.70	6	62	20	14.4	36
3.80	6	66	24	18.3	36
3.90	6	66	24	18.1	36
4.00	6	66	24	18.0	36
4.10	6	66	24	17.8	36
4.20	6	66	24	17.7	36
4.30	6	66	24	17.5	36
4.40	6	66	24	17.4	36
4.50	6	66	24	17.2	36
4.60	6	66	24	17.1	36
4.65	6	66	24	17.0	36
4.70	6	66	24	16.9	36

11 700 ...		11 701 ...		11 713 ...		11 714 ...	
£	01000	£	01000	£	01000	£	01000
T1/9C		T1/9C		T1/9C		T1/9C	
31.45	01100			36.94	01100		
31.45	01200			36.94	01200		
31.45	01300			36.94	01300		
31.45	01400			36.94	01400		
31.45	01500			36.94	01500		
31.45	01600			36.94	01600		
31.45	01700			36.94	01700		
31.45	01800			36.94	01800		
31.45	01900			36.94	01900		
31.45	02000			36.94	02000		
31.45	02100			36.94	02100		
31.45	02200			36.94	02200		
31.45	02300			36.94	02300		
31.45	02400			36.94	02400		
31.45	02500			36.94	02500		
31.45	02600			36.94	02600		
31.45	02700			36.94	02700		
31.45	02800			36.94	02800		
31.45	02900			36.94	02900		
26.60	03000	26.60	03000	32.12	03000	32.12	03000
26.60	03100	26.60	03100	32.12	03100	32.12	03100
26.60	03200	26.60	03200	32.12	03200	32.12	03200
26.60	03250	26.60	03250				
26.60	03300	26.60	03300	32.12	03300	32.12	03300
26.60	03400	26.60	03400	32.12	03400	32.12	03400
26.60	03500	26.60	03500	32.12	03500	32.12	03500
26.60	03600	26.60	03600	32.12	03600	32.12	03600
26.60	03700	26.60	03700	32.12	03700	32.12	03700
26.60	03800	26.60	03800	32.12	03800	32.12	03800
26.60	03900	26.60	03900	32.12	03900	32.12	03900
26.60	04000	26.60	04000	32.12	04000	32.12	04000
26.60	04100	26.60	04100	32.12	04100	32.12	04100
26.60	04200	26.60	04200	32.12	04200	32.12	04200
26.60	04300	26.60	04300	32.12	04300	32.12	04300
26.60	04400	26.60	04400	32.12	04400	32.12	04400
26.60	04500	26.60	04500	32.12	04500	32.12	04500
26.60	04600	26.60	04600	32.12	04600	32.12	04600
26.60	04650	26.60	04650				
26.60	04700	26.60	04700	32.12	04700	32.12	04700

P	●	●	○	○
M	●	●	●	●
K	●	●		
N	○	○	●	●
S			○	○
H				
O			○	○

→ v_c Page 129+133

Ø DC_{m7} for Type UNI / Ø DC_{m7} for Type VA

High Performance Drill, DIN 6537

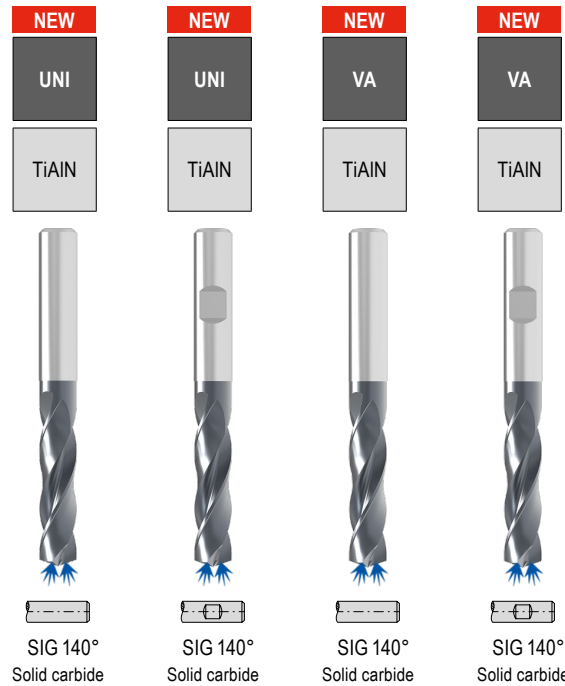
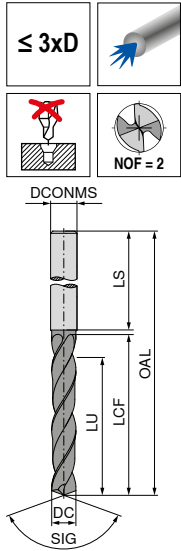

DC _{m7/h7} mm	DCONMS _{h6} mm	OAL mm	LCF mm	LU mm	LS mm
4.80	6	66	28	20.8	36
4.90	6	66	28	20.6	36
5.00	6	66	28	20.5	36
5.10	6	66	28	20.3	36
5.20	6	66	28	20.2	36
5.30	6	66	28	20.0	36
5.40	6	66	28	19.9	36
5.50	6	66	28	19.7	36
5.55	6	66	28	19.6	36
5.60	6	66	28	19.6	36
5.65	6	66	28	19.5	36
5.70	6	66	28	19.4	36
5.80	6	66	28	19.3	36
5.90	6	66	28	19.1	36
6.00	6	66	28	19.0	36
6.10	8	79	34	24.8	36
6.20	8	79	34	24.7	36
6.30	8	79	34	24.5	36
6.40	8	79	34	24.4	36
6.50	8	79	34	24.2	36
6.60	8	79	34	24.1	36
6.70	8	79	34	23.9	36
6.80	8	79	34	23.8	36
6.90	8	79	34	23.6	36
7.00	8	79	34	23.5	36
7.10	8	79	41	30.3	36
7.20	8	79	41	30.2	36
7.30	8	79	41	30.0	36
7.40	8	79	41	29.9	36
7.50	8	79	41	29.7	36
7.55	8	79	41	29.6	36
7.60	8	79	41	29.6	36
7.65	8	79	41	29.5	36
7.70	8	79	41	29.4	36
7.80	8	79	41	29.3	36
7.90	8	79	41	29.1	36
8.00	8	79	41	29.0	36
8.10	10	89	47	34.8	40
8.20	10	89	47	34.7	40
8.30	10	89	47	34.5	40

11 700 ...		11 701 ...		11 713 ...		11 714 ...	
£	Part No.	£	Part No.	£	Part No.	£	Part No.
T1/9C	04800	T1/9C	04800	T1/9C	04800	T1/9C	04800
26.60	04900	26.60	04900	32.12	04900	32.12	04900
26.60	05000	26.60	05000	32.12	05000	32.12	05000
26.60	05100	26.60	05100	32.12	05100	32.12	05100
26.60	05200	26.60	05200	32.12	05200	32.12	05200
26.60	05300	26.60	05300	32.12	05300	32.12	05300
26.60	05400	26.60	05400	32.12	05400	32.12	05400
26.60	05500	26.60	05500	32.12	05500	32.12	05500
26.60	05550	26.60	05550				
26.60	05600	26.60	05600	32.12	05600	32.12	05600
26.60	05650	26.60	05650				
26.60	05700	26.60	05700	32.12	05700	32.12	05700
26.60	05800	26.60	05800	32.12	05800	32.12	05800
26.60	05900	26.60	05900	32.12	05900	32.12	05900
26.60	06000	26.60	06000	32.12	06000	32.12	06000
37.49	06100	37.49	06100	43.88	06100	43.88	06100
37.49	06200	37.49	06200	43.88	06200	43.88	06200
37.49	06300	37.49	06300	43.88	06300	43.88	06300
37.49	06400	37.49	06400	43.88	06400	43.88	06400
37.49	06500	37.49	06500	43.88	06500	43.88	06500
37.49	06600	37.49	06600	43.88	06600	43.88	06600
37.49	06700	37.49	06700	43.88	06700	43.88	06700
37.49	06800	37.49	06800	43.88	06800	43.88	06800
37.49	06900	37.49	06900	43.88	06900	43.88	06900
37.49	07000	37.49	07000	43.88	07000	43.88	07000
37.49	07100	37.49	07100	43.88	07100	43.88	07100
37.49	07200	37.49	07200	43.88	07200	43.88	07200
37.49	07300	37.49	07300	43.88	07300	43.88	07300
37.49	07400	37.49	07400	43.88	07400	43.88	07400
37.49	07500	37.49	07500	43.88	07500	43.88	07500
37.49	07550	37.49	07550				
37.49	07600	37.49	07600	43.88	07600	43.88	07600
37.49	07650	37.49	07650				
37.49	07700	37.49	07700	43.88	07700	43.88	07700
37.49	07800	37.49	07800	43.88	07800	43.88	07800
37.49	07900	37.49	07900	43.88	07900	43.88	07900
37.49	08000	37.49	08000	43.88	08000	43.88	08000
42.33	08100	42.33	08100	49.73	08100	49.73	08100
42.33	08200	42.33	08200	49.73	08200	49.73	08200
42.33	08300	42.33	08300	49.73	08300	49.73	08300

P	●	●	○	○
M	●	●	●	●
K	●	●		
N	○	○	●	●
S			○	○
H				
O			○	○

→ v_c Page 129+133

Ø DC_{m7} for Type UNI / Ø DC_{m7} for Type VA

High Performance Drill, DIN 6537

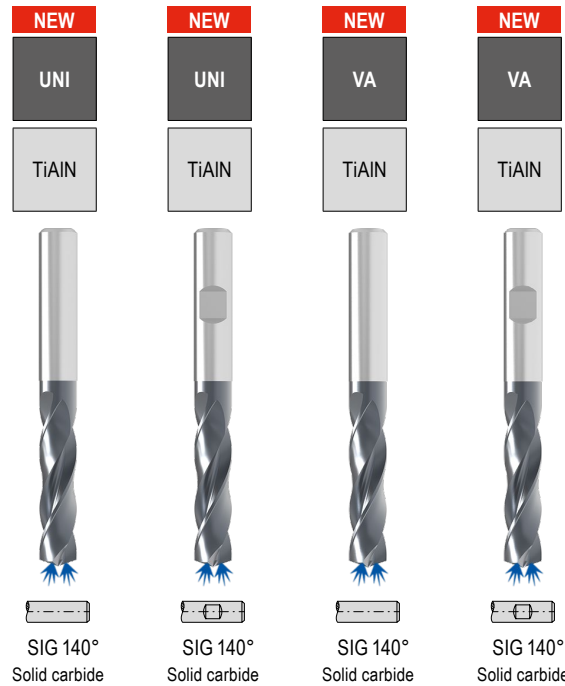
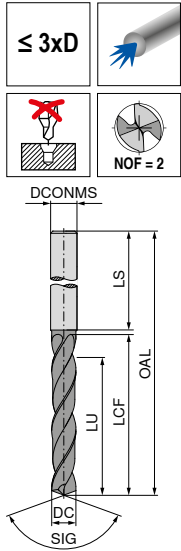

DC _{m7/h7} mm	DCONMS _{h6} mm	OAL mm	LCF mm	LU mm	LS mm
8.40	10	89	47	34.4	40
8.50	10	89	47	34.2	40
8.60	10	89	47	34.1	40
8.70	10	89	47	33.9	40
8.80	10	89	47	33.8	40
8.90	10	89	47	33.6	40
9.00	10	89	47	33.5	40
9.10	10	89	47	33.3	40
9.20	10	89	47	33.2	40
9.30	10	89	47	33.0	40
9.40	10	89	47	32.9	40
9.50	10	89	47	32.7	40
9.60	10	89	47	32.6	40
9.70	10	89	47	32.4	40
9.80	10	89	47	32.3	40
9.90	10	89	47	32.1	40
10.00	10	89	47	32.0	40
10.10	12	102	55	39.8	45
10.20	12	102	55	39.7	45
10.30	12	102	55	39.5	45
10.40	12	102	55	39.4	45
10.50	12	102	55	39.2	45
10.60	12	102	55	39.1	45
10.70	12	102	55	38.9	45
10.80	12	102	55	38.8	45
10.90	12	102	55	38.6	45
11.00	12	102	55	38.5	45
11.10	12	102	55	38.3	45
11.20	12	102	55	38.2	45
11.30	12	102	55	38.0	45
11.40	12	102	55	37.9	45
11.50	12	102	55	37.7	45
11.60	12	102	55	37.6	45
11.70	12	102	55	37.4	45
11.80	12	102	55	37.3	45
11.90	12	102	55	37.1	45
12.00	12	102	55	37.0	45
12.20	14	107	60	41.7	45
12.30	14	107	60	41.5	45
12.50	14	107	60	41.2	45

11 700 ...		11 701 ...		11 713 ...		11 714 ...	
£	08400	£	08400	£	08400	£	08400
T1/9C		T1/9C		T1/9C		T1/9C	
42.33	08400	42.33	08500	49.73	08400	49.73	08500
42.33	08600	42.33	08600	49.73	08600	49.73	08600
42.33	08700	42.33	08700	49.73	08700	49.73	08700
42.33	08800	42.33	08800	49.73	08800	49.73	08800
42.33	08900	42.33	08900	49.73	08900	49.73	08900
42.33	09000	42.33	09000	49.73	09000	49.73	09000
42.33	09100	42.33	09100	49.73	09100	49.73	09100
42.33	09200	42.33	09200	49.73	09200	49.73	09200
42.33	09300	42.33	09300	49.73	09300	49.73	09300
42.33	09400	42.33	09400	49.73	09400	49.73	09400
42.33	09500	42.33	09500	49.73	09500	49.73	09500
42.33	09600	42.33	09600	49.73	09600	49.73	09600
42.33	09700	42.33	09700	49.73	09700	49.73	09700
42.33	09800	42.33	09800	49.73	09800	49.73	09800
42.33	09900	42.33	09900	49.73	09900	49.73	09900
42.33	10000	42.33	10000	49.73	10000	49.73	10000
60.47	10100	60.47	10100	71.66	10100	71.66	10100
60.47	10200	60.47	10200	71.66	10200	71.66	10200
60.47	10300	60.47	10300	71.66	10300	71.66	10300
60.47	10400	60.47	10400	71.66	10400	71.66	10400
60.47	10500	60.47	10500	71.66	10500	71.66	10500
60.47	10600	60.47	10600	71.66	10600	71.66	10600
60.47	10700	60.47	10700	71.66	10700	71.66	10700
60.47	10800	60.47	10800	71.66	10800	71.66	10800
60.47	10900	60.47	10900	71.66	10900	71.66	10900
60.47	11000	60.47	11000	71.66	11000	71.66	11000
60.47	11100	60.47	11100	71.66	11100	71.66	11100
60.47	11200	60.47	11200	71.66	11200	71.66	11200
60.47	11300	60.47	11300	71.66	11300	71.66	11300
60.47	11400	60.47	11400	71.66	11400	71.66	11400
60.47	11500	60.47	11500	71.66	11500	71.66	11500
60.47	11600	60.47	11600	71.66	11600	71.66	11600
60.47	11700	60.47	11700	71.66	11700	71.66	11700
60.47	11800	60.47	11800	71.66	11800	71.66	11800
60.47	11900	60.47	11900	71.66	11900	71.66	11900
81.03	12000	81.03	12000	96.01	12000	96.01	12000
81.03	12300	81.03	12300	96.01	12300	96.01	12300
81.03	12500	81.03	12500	96.01	12500	96.01	12500

P	●	●	○	○
M	●	●	●	●
K	●	●	○	○
N	○	○	●	●
S	○	○	○	○
H	○	○	○	○
O	○	○	○	○

→ v_c Page 129+133

Ø DC_{m7} for Type UNI / Ø DC_{m7} for Type VA

High Performance Drill, DIN 6537

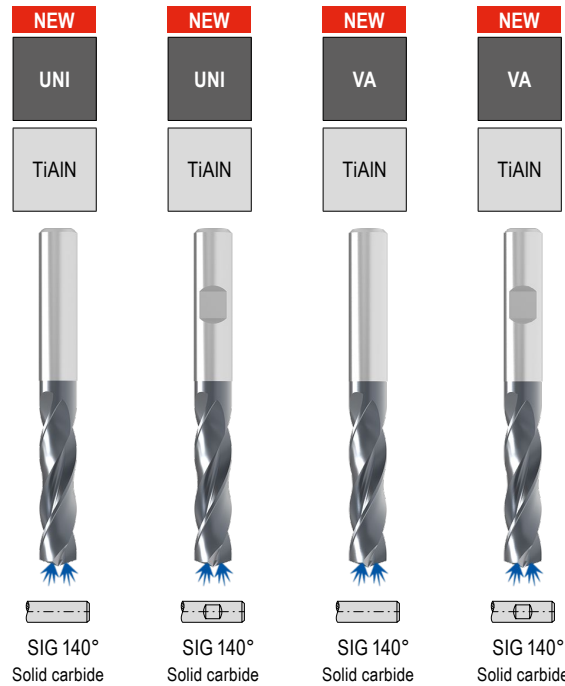
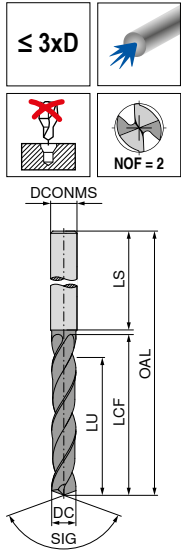

DC _{m7/h7} mm	DCONMS _{h6} mm	OAL mm	LCF mm	LU mm	LS mm
12.70	14	107	60	40.9	45
12.80	14	107	60	40.8	45
12.90	14	107	60	40.6	45
13.00	14	107	60	40.5	45
13.50	14	107	60	39.7	45
13.70	14	107	60	39.4	45
13.80	14	107	60	39.3	45
14.00	14	107	60	39.0	45
14.20	16	115	65	43.7	48
14.40	16	115	65	43.4	48
14.50	16	115	65	43.2	48
14.70	16	115	65	42.9	48
14.80	16	115	65	42.8	48
15.00	16	115	65	42.5	48
15.10	16	115	65	42.3	48
15.20	16	115	65	42.2	48
15.50	16	115	65	41.7	48
15.70	16	115	65	41.4	48
15.80	16	115	65	41.3	48
16.00	16	115	65	41.0	48
16.50	18	123	73	48.2	48
17.00	18	123	73	47.5	48
17.50	18	123	73	46.7	48
18.00	18	123	73	46.0	48
18.50	20	131	79	51.2	50
18.90	20	131	79	50.6	50
19.00	20	131	79	50.5	50
19.30	20	131	79	50.0	50
19.50	20	131	79	49.7	50
20.00	20	131	79	49.0	50

11 700 ...		11 701 ...		11 713 ...		11 714 ...	
£	T1/9C	£	T1/9C	£	T1/9C	£	T1/9C
81.03	12700	81.03	12700	96.01	12700	96.01	12700
81.03	12800	81.03	12800	96.01	12800	96.01	12800
81.03	12900	81.03	12900	96.01	12900	96.01	12900
81.03	13000	81.03	13000	96.01	13000	96.01	13000
81.03	13500	81.03	13500	96.01	13500	96.01	13500
				96.01	13700	96.01	13700
81.03	13800	81.03	13800	96.01	13800	96.01	13800
81.03	14000	81.03	14000	96.01	14000	96.01	14000
105.22	14200	105.22	14200	123.98	14200	123.98	14200
105.22	14400	105.22	14400	123.98	14400	123.98	14400
105.22	14500	105.22	14500	123.98	14500	123.98	14500
				123.98	14700	123.98	14700
105.22	14800	105.22	14800	123.98	14800	123.98	14800
105.22	15000	105.22	15000	123.98	15000	123.98	15000
105.22	15100	105.22	15100	123.98	15100	123.98	15100
105.22	15200	105.22	15200	123.98	15200	123.98	15200
105.22	15500	105.22	15500	123.98	15500	123.98	15500
				123.98	15700	123.98	15700
105.22	15800	105.22	15800	123.98	15800	123.98	15800
105.22	16000	105.22	16000	123.98	16000	123.98	16000
158.43	16500	158.43	16500	188.10	16500	188.10	16500
158.43	17000	158.43	17000	188.10	17000	188.10	17000
158.43	17500	158.43	17500	188.10	17500	188.10	17500
158.43	18000	158.43	18000	188.10	18000	188.10	18000
175.36	18500	175.36	18500	207.25	18500	207.25	18500
175.36	18900	175.36	18900	207.25	18900	207.25	18900
175.36	19000	175.36	19000	207.25	19000	207.25	19000
175.36	19300	175.36	19300	207.25	19300	207.25	19300
175.36	19500	175.36	19500	207.25	19500	207.25	19500
175.36	20000	175.36	20000	207.25	20000	207.25	20000

P	●	●	○	○
M	●	●	●	●
K	●	●	●	●
N	○	○	●	●
S			○	○
H				
O			○	○

→ v_c Page 129+133

Ø DC_{h7} for Type UNI / Ø DC_{m7} for Type VA

WTX – High-performance drill, DIN 6537

▲ Specialist for difficult to machine materials

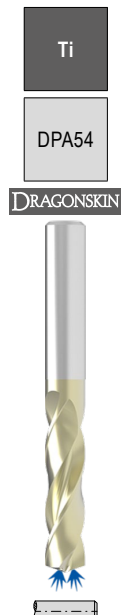
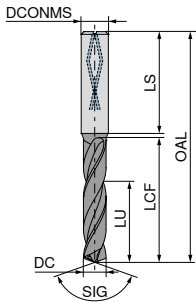
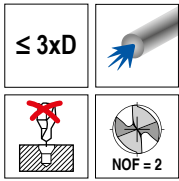

SIG 140°
Solid carbide

10 786 ...

DC _{m7} mm	DCONMS _{h6} mm	OAL mm	LCF mm	LU mm	LS mm	£ T4	
3.00	6	62	20	14	36	72.30	030
3.10	6	62	20	14	36	72.30	031
3.20	6	62	20	14	36	72.30	032
3.30	6	62	20	14	36	72.30	033
3.40	6	62	20	14	36	72.30	034
3.50	6	62	20	14	36	72.30	035
3.60	6	62	20	14	36	72.30	036
3.70	6	62	20	14	36	72.30	037
3.80	6	66	24	17	36	72.30	038
3.90	6	66	24	17	36	72.30	039
3.97	6	66	24	17	36	72.30	900
4.00	6	66	24	17	36	72.30	040
4.10	6	66	24	17	36	72.30	041
4.20	6	66	24	17	36	72.30	042
4.23	6	66	24	17	36	72.30	901
4.30	6	66	24	17	36	72.30	043
4.40	6	66	24	17	36	72.30	044
4.50	6	66	24	17	36	72.30	045
4.60	6	66	24	17	36	72.30	046
4.70	6	66	24	17	36	72.30	047
4.80	6	66	28	20	36	72.30	048
4.90	6	66	28	20	36	72.30	049
5.00	6	66	28	20	36	72.30	050
5.10	6	66	28	20	36	72.30	051
5.20	6	66	28	20	36	72.30	052
5.30	6	66	28	20	36	72.30	053
5.40	6	66	28	20	36	72.30	054
5.50	6	66	28	20	36	72.30	055
5.56	6	66	28	20	36	72.30	902
5.60	6	66	28	20	36	72.30	056
5.70	6	66	28	20	36	72.30	057
5.80	6	66	28	20	36	72.30	058
5.90	6	66	28	20	36	72.30	059
6.00	6	66	28	20	36	72.30	060
6.10	8	79	34	24	36	97.01	061
6.20	8	79	34	24	36	97.01	062
6.30	8	79	34	24	36	97.01	063
6.35	8	79	34	24	36	97.01	903
6.40	8	79	34	24	36	97.01	064
6.50	8	79	34	24	36	97.01	065
6.60	8	79	34	24	36	97.01	066
6.70	8	79	34	24	36	97.01	067
6.80	8	79	34	24	36	97.01	068
6.90	8	79	34	24	36	97.01	069
7.00	8	79	34	24	36	97.01	070
7.10	8	79	41	29	36	97.01	071
7.20	8	79	41	29	36	97.01	072
7.30	8	79	41	29	36	97.01	073
7.40	8	79	41	29	36	97.01	074
7.50	8	79	41	29	36	97.01	075
7.60	8	79	41	29	36	97.01	076

10 786 ...

DC _{m7} mm	DCONMS _{h6} mm	OAL mm	LCF mm	LU mm	LS mm	£ T4	
7.70	8	79	41	29	36	97.01	077
7.80	8	79	41	29	36	97.01	078
7.90	8	79	41	29	36	97.01	079
7.94	8	79	41	29	36	97.01	904
8.00	8	79	41	29	36	97.01	080
8.10	10	89	47	35	40	117.30	081
8.20	10	89	47	35	40	117.30	082
8.30	10	89	47	35	40	117.30	083
8.40	10	89	47	35	40	117.30	084
8.50	10	89	47	35	40	117.30	085
8.60	10	89	47	35	40	117.30	086
8.70	10	89	47	35	40	117.30	087
8.80	10	89	47	35	40	117.30	088
8.90	10	89	47	35	40	117.30	089
9.00	10	89	47	35	40	117.30	090
9.10	10	89	47	35	40	117.30	091
9.20	10	89	47	35	40	117.30	092
9.30	10	89	47	35	40	117.30	093
9.40	10	89	47	35	40	117.30	094
9.50	10	89	47	35	40	117.30	095
9.53	10	89	47	35	40	117.57	905
9.60	10	89	47	35	40	117.30	096
9.70	10	89	47	35	40	117.30	097
9.80	10	89	47	35	40	117.30	098
9.90	10	89	47	35	40	117.30	099
10.00	10	89	47	35	40	117.30	100
10.10	12	102	55	40	45	169.30	101
10.20	12	102	55	40	45	169.30	102
10.30	12	102	55	40	45	169.30	103
10.40	12	102	55	40	45	169.30	104
10.50	12	102	55	40	45	169.30	105
10.60	12	102	55	40	45	169.30	106
10.70	12	102	55	40	45	169.30	107
10.80	12	102	55	40	45	169.30	108
10.90	12	102	55	40	45	169.30	109
11.00	12	102	55	40	45	169.30	110
11.10	12	102	55	40	45	169.30	111
11.11	12	102	55	40	45	169.30	906
11.20	12	102	55	40	45	169.30	112
11.30	12	102	55	40	45	169.30	113
11.40	12	102	55	40	45	169.30	114
11.50	12	102	55	40	45	169.30	115
11.60	12	102	55	40	45	169.30	116
11.70	12	102	55	40	45	169.30	117
11.80	12	102	55	40	45	169.30	118
11.90	12	102	55	40	45	169.30	119
12.00	12	102	55	40	45	169.30	120
12.10	14	107	60	43	45	219.64	121
12.20	14	107	60	43	45	219.64	122
12.30	14	107	60	43	45	219.64	123
12.40	14	107	60	43	45	219.64	124
12.50	14	107	60	43	45	219.64	125
12.60	14	107	60	43	45	219.64	126
12.70	14	107	60	43	45	219.64	907
12.80	14	107	60	43	45	219.64	128
12.90	14	107	60	43	45	219.64	129
13.00	14	107	60	43	45	219.64	130
13.10	14	107	60	43	45	219.64	131
13.20	14	107	60	43	45	219.64	132
13.30	14	107	60	43	45	219.64	133
13.40	14	107	60	43	45	219.64	134
13.50	14	107	60	43	45	219.64	135
13.60	14	107	60	43	45	219.64	136
13.70	14	107	60	43	45	219.64	137
13.80	14	107	60	43	45	219.64	138
13.90	14	107	60	43	45	219.64	139

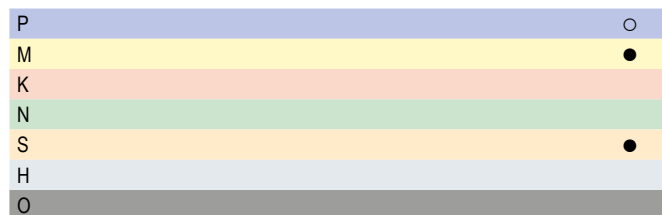

→ v. Page 109

WTX – High-performance drill, DIN 6537

▲ Specialist for difficult to machine materials

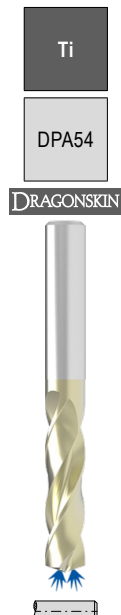
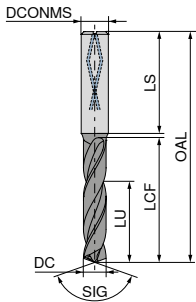
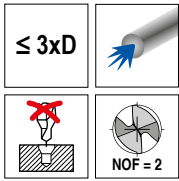

SIG 140°
Solid carbide

10 786 ...

DC _{m7} mm	DCONMS _{h6} mm	OAL mm	LCF mm	LU mm	LS mm	£ T4	
14.0	14	107	60	43	45	219.64	140
14.1	16	115	65	45	48	260.82	141
14.2	16	115	65	45	48	260.82	142
14.3	16	115	65	45	48	260.82	143
14.4	16	115	65	45	48	260.82	144
14.5	16	115	65	45	48	260.82	145
14.6	16	115	65	45	48	260.82	146
14.7	16	115	65	45	48	260.82	147
14.8	16	115	65	45	48	260.82	148
14.9	16	115	65	45	48	260.82	149
15.0	16	115	65	45	48	260.82	150
15.1	16	115	65	45	48	260.82	151
15.2	16	115	65	45	48	260.82	152
15.3	16	115	65	45	48	260.82	153
15.4	16	115	65	45	48	260.82	154
15.5	16	115	65	45	48	260.82	155
15.6	16	115	65	45	48	260.82	156
15.7	16	115	65	45	48	260.82	157
15.8	16	115	65	45	48	260.82	158
15.9	16	115	65	45	48	260.82	159
16.0	16	115	65	45	48	260.82	160
16.1	18	123	73	51	48	260.82	161
16.2	18	123	73	51	48	260.82	162
16.3	18	123	73	51	48	260.82	163
16.4	18	123	73	51	48	260.82	164
16.5	18	123	73	51	48	366.06	165
16.6	18	123	73	51	48	366.06	166
16.7	18	123	73	51	48	366.06	167
16.8	18	123	73	51	48	366.06	168
16.9	18	123	73	51	48	366.06	169
17.0	18	123	73	51	48	366.06	170
17.1	18	123	73	51	48	366.06	171
17.2	18	123	73	51	48	366.06	172
17.3	18	123	73	51	48	366.06	173
17.4	18	123	73	51	48	366.06	174
17.5	18	123	73	51	48	366.06	175
17.6	18	123	73	51	48	366.06	176
17.7	18	123	73	51	48	366.06	177
17.8	18	123	73	51	48	366.06	178
17.9	18	123	73	51	48	366.06	179
18.0	18	123	73	51	48	366.06	180
18.1	20	131	79	55	50	457.59	181
18.2	20	131	79	55	50	457.59	182
18.3	20	131	79	55	50	457.59	183
18.4	20	131	79	55	50	457.59	184
18.5	20	131	79	55	50	457.59	185
18.6	20	131	79	55	50	457.59	186
18.7	20	131	79	55	50	457.59	187
18.8	20	131	79	55	50	457.59	188
18.9	20	131	79	55	50	457.59	189
19.0	20	131	79	55	50	457.59	190

10 786 ...

DC _{m7} mm	DCONMS _{h6} mm	OAL mm	LCF mm	LU mm	LS mm	£ T4	
19.1	20	131	79	55	50	457.59	191
19.2	20	131	79	55	50	457.59	192
19.3	20	131	79	55	50	457.59	193
19.4	20	131	79	55	50	457.59	194
19.5	20	131	79	55	50	457.59	195
19.6	20	131	79	55	50	457.59	196
19.7	20	131	79	55	50	457.59	197
19.8	20	131	79	55	50	457.59	198
19.9	20	131	79	55	50	457.59	199
20.0	20	131	79	55	50	457.59	200

P	○
M	●
K	
N	
S	●
H	
O	

→ v_c Page 109

WTX – High Performance Drill, DIN 6537

▲ universal application
▲ four guidance lands

▲ polished chip flutes
▲ Type ALU 3xD on request

▲ PL = corner chamfers

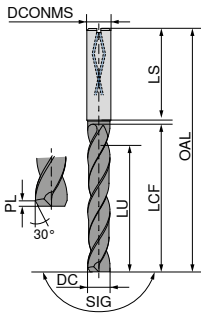
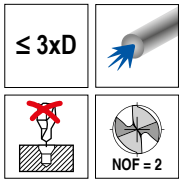

180
Ti800



SIG 180°
Solid carbide

10 720 ...

DC _{m7} mm	DCONMS _{h6} mm	OAL mm	LCF mm	LU mm	LS mm	PL mm	£ T4	
3.00	6	62	20	14	36	0.15	93.81	030
3.10	6	62	20	14	36	0.16	93.81	031
3.20	6	62	20	14	36	0.16	93.81	032
3.30	6	62	20	14	36	0.17	93.81	033
3.40	6	62	20	14	36	0.17	93.81	034
3.50	6	62	20	14	36	0.18	93.81	035
3.60	6	62	20	14	36	0.18	93.81	036
3.70	6	62	20	14	36	0.19	93.81	037
3.80	6	66	24	17	36	0.19	93.81	038
3.90	6	66	24	17	36	0.20	93.81	039
4.00	6	66	24	17	36	0.20	93.81	040
4.10	6	66	24	17	36	0.21	93.81	041
4.20	6	66	24	17	36	0.21	93.81	042
4.30	6	66	24	17	36	0.22	93.81	043
4.40	6	66	24	17	36	0.22	93.81	044
4.50	6	66	24	17	36	0.23	93.81	045
4.60	6	66	24	17	36	0.23	93.81	046
4.65	6	66	24	17	36	0.23	93.81	900
4.70	6	66	24	17	36	0.24	93.81	047
4.80	6	66	28	20	36	0.24	93.81	048
4.90	6	66	28	20	36	0.25	93.81	049
5.00	6	66	28	20	36	0.25	93.81	050
5.10	6	66	28	20	36	0.26	93.81	051
5.20	6	66	28	20	36	0.26	93.81	052
5.30	6	66	28	20	36	0.27	93.81	053
5.40	6	66	28	20	36	0.27	93.81	054
5.50	6	66	28	20	36	0.28	93.81	055
5.55	6	66	28	20	36	0.28	93.81	902
5.60	6	66	28	20	36	0.28	93.81	056
5.70	6	66	28	20	36	0.29	93.81	057
5.80	6	66	28	20	36	0.29	93.81	058
5.90	6	66	28	20	36	0.30	93.81	059
6.00	6	66	28	20	36	0.30	93.81	060
6.10	8	79	34	24	36	0.31	115.08	061
6.20	8	79	34	24	36	0.31	115.08	062
6.30	8	79	34	24	36	0.32	115.08	063
6.40	8	79	34	24	36	0.32	115.08	064
6.50	8	79	34	24	36	0.33	115.08	065
6.60	8	79	34	24	36	0.33	115.08	066
6.70	8	79	34	24	36	0.34	115.08	067
6.80	8	79	34	24	36	0.34	115.08	068
6.90	8	79	34	24	36	0.35	115.08	069
7.00	8	79	34	24	36	0.35	115.08	070
7.10	8	79	41	29	36	0.36	115.08	071
7.20	8	79	41	29	36	0.36	115.08	072
7.30	8	79	41	29	36	0.37	115.08	073
7.40	8	79	41	29	36	0.37	115.08	074
7.50	8	79	41	29	36	0.38	115.08	075
7.60	8	79	41	29	36	0.38	115.08	076
7.70	8	79	41	29	36	0.39	115.08	077
7.80	8	79	41	29	36	0.39	115.08	078
7.90	8	79	41	29	36	0.40	115.08	079
8.00	8	79	41	29	36	0.40	115.08	080
8.10	10	89	47	35	40	0.41	159.00	081

10 720 ...

DC _{m7} mm	DCONMS _{h6} mm	OAL mm	LCF mm	LU mm	LS mm	PL mm	£ T4	
8.20	10	89	47	35	40	0.41	159.00	082
8.30	10	89	47	35	40	0.42	159.00	083
8.40	10	89	47	35	40	0.42	159.00	084
8.50	10	89	47	35	40	0.43	159.00	085
8.60	10	89	47	35	40	0.43	159.00	086
8.70	10	89	47	35	40	0.44	159.00	087
8.80	10	89	47	35	40	0.44	159.00	088
8.90	10	89	47	35	40	0.45	159.00	089
9.00	10	89	47	35	40	0.45	159.00	090
9.10	10	89	47	35	40	0.46	159.00	091
9.20	10	89	47	35	40	0.46	159.00	092
9.30	10	89	47	35	40	0.47	159.00	093
9.40	10	89	47	35	40	0.47	159.00	094
9.50	10	89	47	35	40	0.48	159.00	095
9.60	10	89	47	35	40	0.48	159.00	096
9.70	10	89	47	35	40	0.49	159.00	097
9.80	10	89	47	35	40	0.49	159.00	098
9.90	10	89	47	35	40	0.50	159.00	099
10.00	10	89	47	35	40	0.50	159.00	100
10.10	12	100	53	38	45	0.51	166.73	101
10.20	12	100	53	38	45	0.51	200.29	102
10.30	12	100	53	38	45	0.52	200.29	103
10.40	12	100	53	38	45	0.52	200.29	104
10.50	12	100	53	38	45	0.53	200.29	105
10.60	12	100	53	38	45	0.53	200.29	106
10.70	12	100	53	38	45	0.54	200.29	107
10.80	12	100	53	38	45	0.54	200.29	108
10.90	12	100	53	38	45	0.55	200.29	109
11.00	12	100	53	38	45	0.55	200.29	110
11.10	12	100	53	38	45	0.56	200.29	111
11.20	12	100	53	38	45	0.56	200.29	112
11.30	12	100	53	38	45	0.57	200.29	113
11.40	12	100	53	38	45	0.57	200.29	114
11.50	12	100	53	38	45	0.58	200.29	115
11.60	12	100	53	38	45	0.58	200.29	116
11.70	12	100	53	38	45	0.59	200.29	117
11.80	12	100	53	38	45	0.59	200.29	118
11.90	12	100	53	38	45	0.60	200.29	119
12.00	12	100	53	38	45	0.60	200.29	120
12.50	14	105	58	41	45	0.63	325.02	125
12.80	14	105	58	41	45	0.64	325.02	128
13.00	14	105	58	41	45	0.65	325.02	130
13.50	14	105	58	41	45	0.68	325.02	135
13.80	14	105	58	41	45	0.69	325.02	138
14.00	14	105	58	41	45	0.70	325.02	140
14.50	16	113	63	43	48	0.73	340.80	145
14.80	16	113	63	43	48	0.74	423.41	148
15.00	16	113	63	43	48	0.75	423.41	150
15.50	16	113	63	43	48	0.78	423.41	155
15.80	16	113	63	43	48	0.79	423.41	158
16.00	16	113	63	43	48	0.80	423.41	160
16.50	18	121	71	49	48	0.83	452.18	165
16.80	18	121	71	49	48	0.84	551.66	168
17.00	18	121	71	49	48	0.85	551.66	170
17.50	18	121	71	49	48	0.88	551.66	175
17.80	18	121	71	49	48	0.89	551.66	178
18.00	18	121	71	49	48	0.90	551.66	180
18.50	20	129	77	53	50	0.93	551.66	185
18.80	20	129	77	53	50	0.94	551.66	188
19.00	20	129	77	53	50	0.95	551.66	190
19.50	20	129	77	53	50	0.98	551.66	195
19.80	20	129	77	53	50	0.99	551.66	198
20.00	20	129	77	53	50	1.00	551.66	200

P	●
M	●
K	●
N	
S	
H	
O	

→ v. Page 126

WTX – High-feed drills, DIN 6537

- ▲ Four fluted high-feed drill
- ▲ Specialises in steel processing
- ▲ Has four spiral coolant holes

- ▲ Innovative cutting edge geometry guarantees high positioning accuracy

- ▲ Outstanding drilling quality in terms of tolerance, surface finish and position

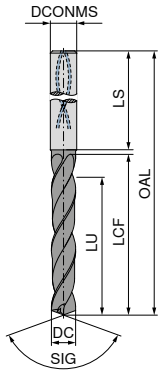
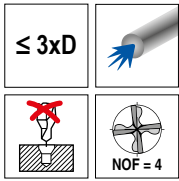

HFDS
DPX14S
DRAGONSKIN



SIG 130°
Solid carbide

10 797 ...

DC _{m7} mm	DCONMS _{h6} mm	OAL mm	LCF mm	LU mm	LS mm	£ T4	
6.0	8	79	41	29	36	103.19	06000
6.1	10	89	47	35	40	140.66	06100
6.2	10	89	47	35	40	140.66	06200
6.3	10	89	47	35	40	140.66	06300
6.4	10	89	47	35	40	140.66	06400
6.5	10	89	47	35	40	140.66	06500
6.6	10	89	47	35	40	140.66	06600
6.7	10	89	47	35	40	140.66	06700
6.8	10	89	47	35	40	140.66	06800
6.9	10	89	47	35	40	140.66	06900
7.0	10	89	47	35	40	140.66	07000
7.1	10	89	47	35	40	140.66	07100
7.2	10	89	47	35	40	140.66	07200
7.3	10	89	47	35	40	140.66	07300
7.4	10	89	47	35	40	140.66	07400
7.5	10	89	47	35	40	140.66	07500
7.6	10	89	47	35	40	140.66	07600
7.7	10	89	47	35	40	140.66	07700
7.8	10	89	47	35	40	140.66	07800
7.9	10	89	47	35	40	140.66	07900
8.0	10	89	47	35	40	140.66	08000
8.1	12	102	55	40	45	190.81	08100
8.2	12	102	55	40	45	190.81	08200
8.3	12	102	55	40	45	190.81	08300
8.4	12	102	55	40	45	190.81	08400
8.5	12	102	55	40	45	190.81	08500
8.6	12	102	55	40	45	190.81	08600
8.7	12	102	55	40	45	190.81	08700
8.8	12	102	55	40	45	190.81	08800
8.9	12	102	55	40	45	190.81	08900
9.0	12	102	55	40	45	190.81	09000
9.1	12	102	55	40	45	190.81	09100
9.2	12	102	55	40	45	190.81	09200
9.3	12	102	55	40	45	190.81	09300
9.4	12	102	55	40	45	190.81	09400
9.5	12	102	55	40	45	190.81	09500
9.6	12	102	55	40	45	190.81	09600
9.7	12	102	55	40	45	190.81	09700
9.8	12	102	55	40	45	190.81	09800
9.9	12	102	55	40	45	190.81	09900
10.0	12	102	55	40	45	190.81	10000
10.2	14	107	60	43	45	253.24	10200
10.5	14	107	60	43	45	253.24	10500
11.0	14	107	60	43	45	253.24	11000
11.5	14	107	60	43	45	253.24	11500
12.0	14	107	60	43	45	253.24	12000
12.5	16	115	65	45	48	343.90	12500
13.0	16	115	65	45	48	343.90	13000

10 797 ...

DC _{m7} mm	DCONMS _{h6} mm	OAL mm	LCF mm	LU mm	LS mm	£ T4	
14.0	16	115	65	45	48	343.90	14000
14.3	18	123	73	51	48	428.42	14300
14.5	18	123	73	51	48	428.42	14500
15.0	18	123	73	51	48	428.42	15000
16.0	18	123	73	51	48	428.42	16000

P	●
M	○
K	●
N	○
S	○
H	○
O	○

→ v_c Page 125

WTX – High Performance Drill, DIN 6537

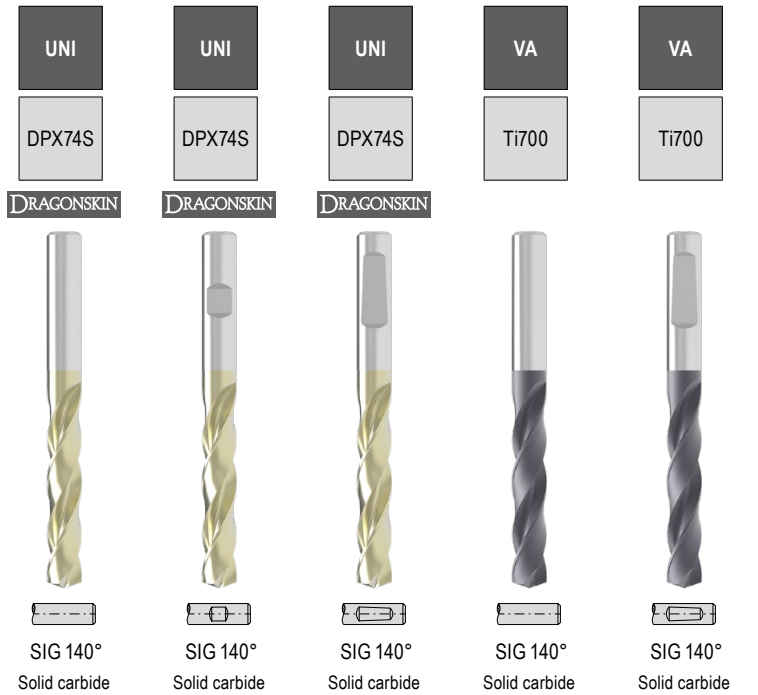
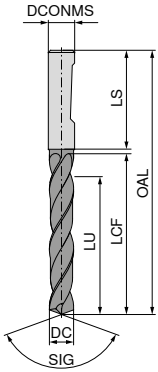
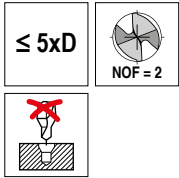

DC _{m7} mm	DCONMS _{h6} mm	OAL mm	LCF mm	LU mm	LS mm	11 783 ...		11 784 ...		11 782 ...		10 740 ...		10 741 ...	
						£ T7	03000	£ T7	03000	£ T7	03000	£ T4	030	£ T4	030
3.00	6	66	28	23	36	45.68	03000	45.68	03000	45.68	03000	88.00	030	88.00	030
3.10	6	66	28	23	36	45.68	03100	45.68	03100	45.68	03100	88.00	031	88.00	031
3.15	6	66	28	23	36	45.68	03150	45.68	03150	45.68	03150				
3.20	6	66	28	23	36	45.68	03200	45.68	03200	45.68	03200	88.00	032	88.00	032
3.22	6	66	28	23	36	45.68	03220	45.68	03220	45.68	03220				
3.25	6	66	28	23	36	45.68	03250	45.68	03250	45.68	03250				
3.30	6	66	28	23	36	45.68	03300	45.68	03300	45.68	03300	88.00	033	88.00	033
3.40	6	66	28	23	36	45.68	03400	45.68	03400	45.68	03400	88.00	034	88.00	034
3.50	6	66	28	23	36	45.68	03500	45.68	03500	45.68	03500	88.00	035	88.00	035
3.60	6	66	28	23	36	45.68	03600	45.68	03600	45.68	03600	88.00	036	88.00	036
3.70	6	66	28	23	36	45.68	03700	45.68	03700	45.68	03700	88.00	037	88.00	037
3.80	6	74	36	29	36	45.68	03800	45.68	03800	45.68	03800	88.00	038	88.00	038
3.85	6	74	36	29	36	45.68	03850	45.68	03850	45.68	03850				
3.90	6	74	36	29	36	45.68	03900	45.68	03900	45.68	03900	88.00	039	88.00	039
4.00	6	74	36	29	36	45.68	04000	45.68	04000	45.68	04000	88.00	040	88.00	040
4.10	6	74	36	29	36	45.68	04100	45.68	04100	45.68	04100	88.00	041	88.00	041
4.20	6	74	36	29	36	45.68	04200	45.68	04200	45.68	04200	88.00	042	88.00	042
4.25	6	74	36	29	36	45.68	04250	45.68	04250	45.68	04250				
4.30	6	74	36	29	36	45.68	04300	45.68	04300	45.68	04300	88.00	043	88.00	043
4.35	6	74	36	29	36	45.68	04350	45.68	04350	45.68	04350				
4.40	6	74	36	29	36	45.68	04400	45.68	04400	45.68	04400	88.00	044	88.00	044
4.45	6	74	36	29	36	45.68	04450	45.68	04450	45.68	04450				
4.50	6	74	36	29	36	45.68	04500	45.68	04500	45.68	04500	88.00	045	88.00	045
4.60	6	74	36	29	36	45.68	04600	45.68	04600	45.68	04600	88.00	046	88.00	046
4.65	6	74	36	29	36	45.68	04650	45.68	04650	45.68	04650				
4.70	6	74	36	29	36	45.68	04700	45.68	04700	45.68	04700	88.00	047	88.00	047
4.80	6	82	44	35	36	45.68	04800	45.68	04800	45.68	04800	88.00	048	88.00	048
4.90	6	82	44	35	36	45.68	04900	45.68	04900	45.68	04900	88.00	049	88.00	049
4.95	6	82	44	35	36	45.68	04950	45.68	04950	45.68	04950				
5.00	6	82	44	35	36	45.68	05000	45.68	05000	45.68	05000	88.00	050	88.00	050
5.05	6	82	44	35	36	45.68	05050	45.68	05050	45.68	05050				
5.10	6	82	44	35	36	45.68	05100	45.68	05100	45.68	05100	88.00	051	88.00	051
5.20	6	82	44	35	36	45.68	05200	45.68	05200	45.68	05200	88.00	052	88.00	052
5.30	6	82	44	35	36	45.68	05300	45.68	05300	45.68	05300	88.00	053	88.00	053
5.40	6	82	44	35	36	45.68	05400	45.68	05400	45.68	05400	88.00	054	88.00	054
5.50	6	82	44	35	36	45.68	05500	45.68	05500	45.68	05500	88.00	055	88.00	055
5.55	6	82	44	35	36	45.68	05550	45.68	05550	45.68	05550				
5.60	6	82	44	35	36	45.68	05600	45.68	05600	45.68	05600	88.00	056	88.00	056
5.70	6	82	44	35	36	45.68	05700	45.68	05700	45.68	05700	88.00	057	88.00	057
5.75	6	82	44	35	36	45.68	05750	45.68	05750	45.68	05750				
5.80	6	82	44	35	36	45.68	05800	45.68	05800	45.68	05800	88.00	058	88.00	058
5.90	6	82	44	35	36	45.68	05900	45.68	05900	45.68	05900	88.00	059	88.00	059

P	●	●	●	○	○
M				●	●
K	●	●	●	○	○
N				○	○
S				●	●
H	○	○	○		
O					

WTX – High Performance Drill, DIN 6537

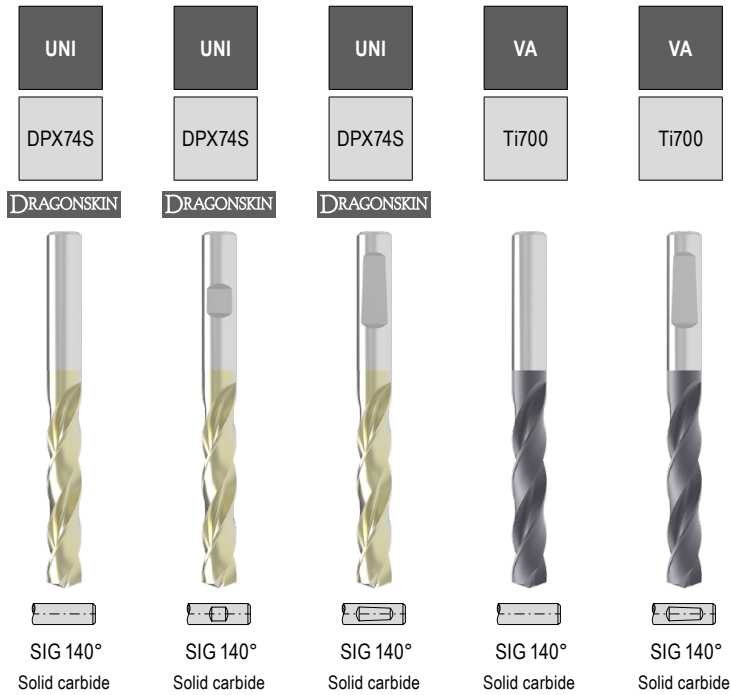
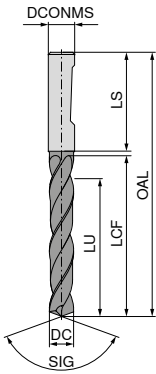
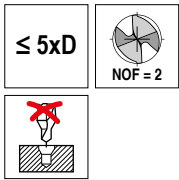

DC _{m7} mm	DCONMS _{h6} mm	OAL mm	LCF mm	LU mm	LS mm	11 783 ...		11 784 ...		11 782 ...		10 740 ...		10 741 ...	
						£ T7	05950	£ T7	05950	£ T7	05950	£ T4	060	£ T4	060
5.95	6	82	44	35	36	45.68	05950	45.68	06000	45.68	06000	106.46	060	106.46	060
6.00	6	82	44	35	36	45.68	06000	45.68	06000	45.68	06000	106.46	061	106.46	061
6.10	8	91	53	43	36	49.62	06100	49.62	06100	49.62	06100	106.46	062	106.46	062
6.20	8	91	53	43	36	49.62	06200	49.62	06200	49.62	06200	106.46	063	106.46	063
6.30	8	91	53	43	36	49.62	06300	49.62	06300	49.62	06300	106.46	064	106.46	064
6.40	8	91	53	43	36	49.62	06400	49.62	06400	49.62	06400	106.46	065	106.46	065
6.50	8	91	53	43	36	49.62	06500	49.62	06500	49.62	06500	106.46	066	106.46	066
6.60	8	91	53	43	36	49.62	06600	49.62	06600	49.62	06600	106.46	067	106.46	067
6.70	8	91	53	43	36	49.62	06700	49.62	06700	49.62	06700	106.46	068	106.46	068
6.80	8	91	53	43	36	49.62	06800	49.62	06800	49.62	06800	106.46	069	106.46	069
6.90	8	91	53	43	36	49.62	06900	49.62	06900	49.62	06900	106.46	070	106.46	070
7.00	8	91	53	43	36	49.62	07000	49.62	07000	49.62	07000	106.46	071	106.46	071
7.10	8	91	53	43	36	49.62	07100	49.62	07100	49.62	07100	106.46	072	106.46	072
7.20	8	91	53	43	36	49.62	07200	49.62	07200	49.62	07200	106.46	073	106.46	073
7.30	8	91	53	43	36	49.62	07300	49.62	07300	49.62	07300	106.46	074	106.46	074
7.40	8	91	53	43	36	49.62	07400	49.62	07400	49.62	07400	106.46	075	106.46	075
7.45	8	91	53	43	36	49.62	07450	49.62	07450	49.62	07450	106.46	076	106.46	076
7.50	8	91	53	43	36	49.62	07500	49.62	07500	49.62	07500	106.46	077	106.46	077
7.60	8	91	53	43	36	49.62	07600	49.62	07600	49.62	07600	106.46	078	106.46	078
7.70	8	91	53	43	36	49.62	07700	49.62	07700	49.62	07700	106.46	079	106.46	079
7.80	8	91	53	43	36	49.62	07800	49.62	07800	49.62	07800	106.46	080	106.46	080
7.90	8	91	53	43	36	49.62	07900	49.62	07900	49.62	07900	106.46	081	106.46	081
8.00	8	91	53	43	36	49.62	08000	49.62	08000	49.62	08000	106.46	082	106.46	082
8.10	10	103	61	49	40	53.35	08100	53.35	08100	53.35	08100	124.56	083	124.56	083
8.20	10	103	61	49	40	53.35	08200	53.35	08200	53.35	08200	124.56	084	124.56	084
8.30	10	103	61	49	40	53.35	08300	53.35	08300	53.35	08300	124.56	085	124.56	085
8.40	10	103	61	49	40	53.35	08400	53.35	08400	53.35	08400	124.56	086	124.56	086
8.50	10	103	61	49	40	53.35	08500	53.35	08500	53.35	08500	124.56	087	124.56	087
8.60	10	103	61	49	40	53.35	08600	53.35	08600	53.35	08600	124.56	088	124.56	088
8.70	10	103	61	49	40	53.35	08700	53.35	08700	53.35	08700	124.56	089	124.56	089
8.80	10	103	61	49	40	53.35	08800	53.35	08800	53.35	08800	124.56	090	124.56	090
8.90	10	103	61	49	40	53.35	08900	53.35	08900	53.35	08900	124.56	091	124.56	091
9.00	10	103	61	49	40	53.35	09000	53.35	09000	53.35	09000	124.56	092	124.56	092
9.10	10	103	61	49	40	53.35	09100	53.35	09100	53.35	09100	124.56	093	124.56	093
9.20	10	103	61	49	40	53.35	09200	53.35	09200	53.35	09200	124.56	094	124.56	094
9.30	10	103	61	49	40	53.35	09300	53.35	09300	53.35	09300	124.56	095	124.56	095
9.35	10	103	61	49	40	53.35	09350	53.35	09350	53.35	09350	124.56	096	124.56	096
9.40	10	103	61	49	40	53.35	09400	53.35	09400	53.35	09400	124.56	097	124.56	097
9.45	10	103	61	49	40	53.35	09450	53.35	09450	53.35	09450	124.56	098	124.56	098
9.50	10	103	61	49	40	53.35	09500	53.35	09500	53.35	09500	124.56	099	124.56	099
9.60	10	103	61	49	40	53.35	09600	53.35	09600	53.35	09600	124.56	100	124.56	100
9.70	10	103	61	49	40	53.35	09700	53.35	09700	53.35	09700	124.56	101	124.56	101

P	●	●	●	○	○
M	●	●	●	●	●
K	●	●	●	○	○
N	○	○	○	○	○
S	●	●	●	●	●
H	○	○	○	○	○
O	○	○	○	○	○

WTX – High Performance Drill, DIN 6537

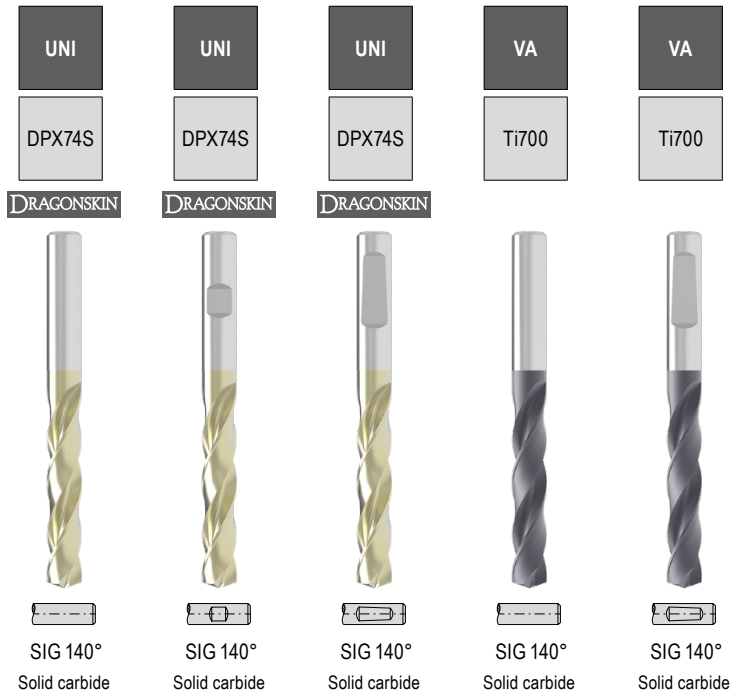
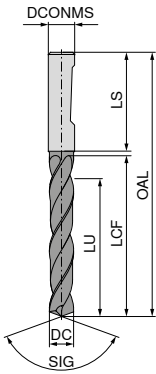
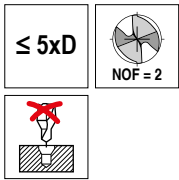

DC _{m7} mm	DCONMS _{h6} mm	OAL mm	LCF mm	LU mm	LS mm	11 783 ...		11 784 ...		11 782 ...		10 740 ...		10 741 ...	
						£ T7	09800	£ T7	09800	£ T7	09800	£ T4	098	£ T4	098
9.80	10	103	61	49	40	53.35	09800	53.35	09800	53.35	09800	124.56	098	124.56	098
9.90	10	103	61	49	40	53.35	09900	53.35	09900	53.35	09900	124.56	099	124.56	099
10.00	10	103	61	49	40	53.35	10000	53.35	10000	53.35	10000	124.56	100	124.56	100
10.10	12	118	71	56	45	77.42	10100	77.42	10100	77.42	10100	176.57	101	176.57	101
10.20	12	118	71	56	45	77.42	10200	77.42	10200	77.42	10200	176.57	102	176.57	102
10.30	12	118	71	56	45	77.42	10300	77.42	10300	77.42	10300	176.57	103	176.57	103
10.40	12	118	71	56	45	77.42	10400	77.42	10400	77.42	10400	176.57	104	176.57	104
10.50	12	118	71	56	45	77.42	10500	77.42	10500	77.42	10500	176.57	105	176.57	105
10.55	12	118	71	56	45	77.42	10550	77.42	10550	77.42	10550				
10.60	12	118	71	56	45	77.42	10600	77.42	10600	77.42	10600	176.57	106	176.57	106
10.70	12	118	71	56	45	77.42	10700	77.42	10700	77.42	10700	176.57	107	176.57	107
10.75	12	118	71	56	45	77.42	10750	77.42	10750	77.42	10750				
10.80	12	118	71	56	45	77.42	10800	77.42	10800	77.42	10800	176.57	108	176.57	108
10.90	12	118	71	56	45	77.42	10900	77.42	10900	77.42	10900	176.57	109	176.57	109
11.00	12	118	71	56	45	77.42	11000	77.42	11000	77.42	11000	176.57	110	176.57	110
11.10	12	118	71	56	45	77.42	11100	77.42	11100	77.42	11100	176.57	111	176.57	111
11.20	12	118	71	56	45	77.42	11200	77.42	11200	77.42	11200	176.57	112	176.57	112
11.25	12	118	71	56	45	77.42	11250	77.42	11250	77.42	11250				
11.30	12	118	71	56	45	77.42	11300	77.42	11300	77.42	11300	176.57	113	176.57	113
11.35	12	118	71	56	45	77.42	11350	77.42	11350	77.42	11350				
11.40	12	118	71	56	45	77.42	11400	77.42	11400	77.42	11400	176.57	114	176.57	114
11.45	12	118	71	56	45	77.42	11450	77.42	11450	77.42	11450				
11.50	12	118	71	56	45	77.42	11500	77.42	11500	77.42	11500	176.57	115	176.57	115
11.60	12	118	71	56	45	77.42	11600	77.42	11600	77.42	11600	176.57	116	176.57	116
11.70	12	118	71	56	45	77.42	11700	77.42	11700	77.42	11700	176.57	117	176.57	117
11.80	12	118	71	56	45	77.42	11800	77.42	11800	77.42	11800	176.57	118	176.57	118
11.90	12	118	71	56	45	77.42	11900	77.42	11900	77.42	11900	176.57	119	176.57	119
12.00	12	118	71	56	45	77.42	12000	77.42	12000	77.42	12000	176.57	120	176.57	120
12.15	14	124	77	60	45	103.86	12150	103.86	12150	103.86	12150				
12.25	14	124	77	60	45	103.86	12250	103.86	12250	103.86	12250				
12.50	14	124	77	60	45	103.86	12500	103.86	12500	103.86	12500	233.35	125	233.35	125
12.55	14	124	77	60	45	103.86	12550	103.86	12550	103.86	12550				
12.70	14	124	77	60	45	103.86	12700	103.86	12700	103.86	12700				
12.80	14	124	77	60	45	103.86	12800	103.86	12800	103.86	12800	233.35	128	233.35	128
12.90	14	124	77	60	45	103.86	12900	103.86	12900	103.86	12900				
13.00	14	124	77	60	45	103.86	13000	103.86	13000	103.86	13000	233.35	130	233.35	130
13.10	14	124	77	60	45	103.86	13100	103.86	13100	103.86	13100				
13.30	14	124	77	60	45	103.86	13300	103.86	13300	103.86	13300				
13.35	14	124	77	60	45	103.86	13350	103.86	13350	103.86	13350				
13.50	14	124	77	60	45	103.86	13500	103.86	13500	103.86	13500	233.35	135	233.35	135
13.70	14	124	77	60	45	103.86	13700	103.86	13700	103.86	13700				
13.80	14	124	77	60	45	103.86	13800	103.86	13800	103.86	13800	233.35	138	233.35	138

P	●	●	●	○	○
M				●	●
K	●	●	●	○	○
N				○	○
S				●	●
H	○	○	○		
O					

WTX – High Performance Drill, DIN 6537

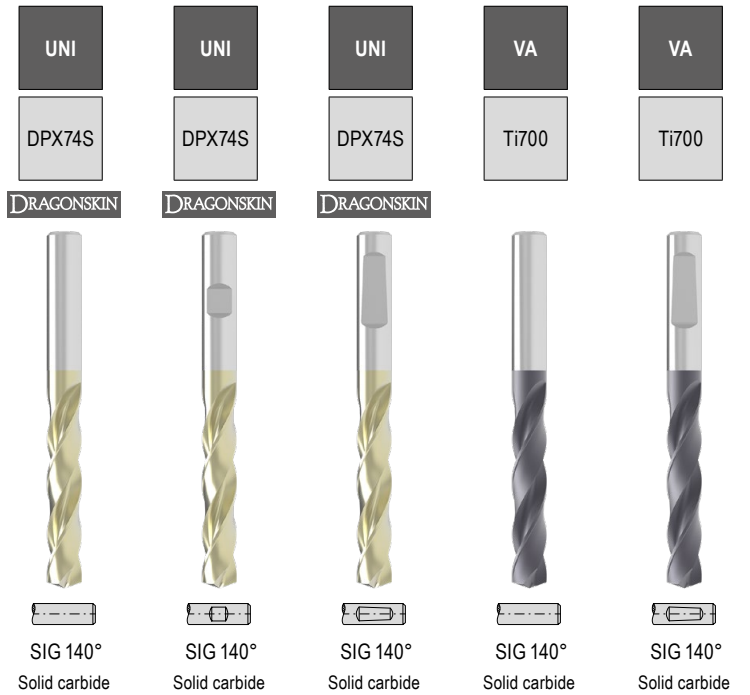
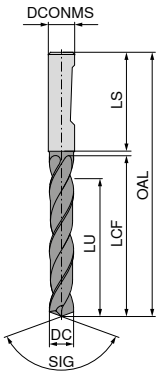
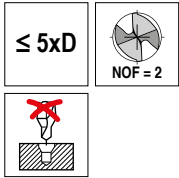

DC _{m7} mm	DCONMS _{h6} mm	OAL mm	LCF mm	LU mm	LS mm	11 783 ...		11 784 ...		11 782 ...		10 740 ...		10 741 ...	
						£ T7	14000	£ T7	14000	£ T7	14000	£ T4	140	£ T4	140
14.00	14	124	77	60	45	103.86	14000	103.86	14000	103.86	14000	289.87	140	289.87	140
14.20	16	133	83	63	48	133.34	14200	133.34	14200	133.34	14200				
14.50	16	133	83	63	48	133.34	14500	133.34	14500	133.34	14500	304.37	145	304.37	145
14.80	16	133	83	63	48	133.34	14800	133.34	14800	133.34	14800	304.37	148	304.37	148
15.00	16	133	83	63	48	133.34	15000	133.34	15000	133.34	15000	304.37	150	304.37	150
15.10	16	133	83	63	48	133.34	15100	133.34	15100	133.34	15100				
15.25	16	133	83	63	48	133.34	15250	133.34	15250	133.34	15250				
15.30	16	133	83	63	48	133.34	15300	133.34	15300	133.34	15300				
15.35	16	133	83	63	48	133.34	15350	133.34	15350	133.34	15350				
15.50	16	133	83	63	48	133.34	15500	133.34	15500	133.34	15500	304.37	155	304.37	155
15.60	16	133	83	63	48	133.34	15600	133.34	15600	133.34	15600				
15.80	16	133	83	63	48	133.34	15800	133.34	15800	133.34	15800	304.37	158	304.37	158
16.00	16	133	83	63	48	133.34	16000	133.34	16000	133.34	16000	304.37	160	304.37	160
16.05	18	143	93	71	48	226.56	16050	226.56	16050	226.56	16050				
16.50	18	143	93	71	48	226.56	16500	226.56	16500	226.56	16500	444.39	165	444.39	165
16.80	18	143	93	71	48	226.56	16800	226.56	16800	226.56	16800	444.39	168	444.39	168
16.90	18	143	93	71	48	226.56	16900	226.56	16900	226.56	16900				
17.00	18	143	93	71	48	226.56	17000	226.56	17000	226.56	17000	444.39	170	444.39	170
17.50	18	143	93	71	48	226.56	17500	226.56	17500	226.56	17500	444.39	175	444.39	175
17.60	18	143	93	71	48	226.56	17600	226.56	17600	226.56	17600				
17.80	18	143	93	71	48	226.56	17800	226.56	17800	226.56	17800	444.39	178	444.39	178
18.00	18	143	93	71	48	226.56	18000	226.56	18000	226.56	18000	559.01	180	559.01	180
18.50	20	153	101	77	50	254.19	18500	254.19	18500	254.19	18500	587.00	185	587.00	185
18.80	20	153	101	77	50	254.19	18800	254.19	18800	254.19	18800	587.00	188	587.00	188
18.90	20	153	101	77	50	254.19	18900	254.19	18900	254.19	18900				
19.00	20	153	101	77	50	254.19	19000	254.19	19000	254.19	19000	587.00	190	587.00	190
19.35	20	153	101	77	50	254.19	19350	254.19	19350	254.19	19350				
19.50	20	153	101	77	50	254.19	19500	254.19	19500	254.19	19500	587.00	195	587.00	195
19.60	20	153	101	77	50	254.19	19600	254.19	19600	254.19	19600				
19.80	20	153	101	77	50	254.19	19800	254.19	19800	254.19	19800	587.00	198	587.00	198
20.00	20	153	101	77	50	254.19	20000	254.19	20000	254.19	20000	818.50	200	818.50	200

P	●	●	●	○	○
M	●	●	●	●	●
K	●	●	●	○	○
N	○	○	○	○	○
S	○	○	○	●	●
H	○	○	○	○	○
O	○	○	○	○	○

→ v_c Page 115+116

High Performance Drill, DIN 6537

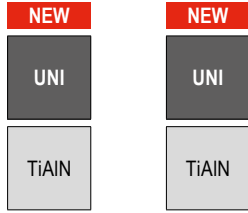
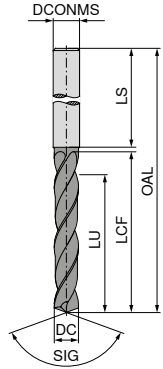

DC _{h7} mm	DCONMS _{h6} mm	OAL mm	LCF mm	LU mm	LS mm	11 710 ...		11 709 ...	
						£ T1/9C	03000	£ T1/9C	03000
3.00	6	66	28	23.5	36	30.24	03000	30.24	03000
3.10	6	66	28	23.3	36	30.24	03100	30.24	03100
3.20	6	66	28	23.2	36	30.24	03200	30.24	03200
3.25	6	66	28	23.1	36	30.24	03250	30.24	03250
3.30	6	66	28	23.0	36	30.24	03300	30.24	03300
3.40	6	66	28	22.9	36	30.24	03400	30.24	03400
3.50	6	66	28	22.7	36	30.24	03500	30.24	03500
3.60	6	66	28	22.6	36	30.24	03600	30.24	03600
3.70	6	66	28	22.4	36	30.24	03700	30.24	03700
3.80	6	74	36	30.3	36	30.24	03800	30.24	03800
3.90	6	74	36	30.1	36	30.24	03900	30.24	03900
4.00	6	74	36	30.0	36	30.24	04000	30.24	04000
4.10	6	74	36	29.8	36	30.24	04100	30.24	04100
4.20	6	74	36	29.7	36	30.24	04200	30.24	04200
4.30	6	74	36	29.5	36	30.24	04300	30.24	04300
4.40	6	74	36	29.4	36	30.24	04400	30.24	04400
4.50	6	74	36	29.2	36	30.24	04500	30.24	04500
4.60	6	74	36	29.1	36	30.24	04600	30.24	04600
4.65	6	74	36	29.0	36	30.24	04650	30.24	04650
4.70	6	74	36	28.9	36	30.24	04700	30.24	04700
4.80	6	82	44	36.8	36	30.24	04800	30.24	04800
4.90	6	82	44	36.6	36	30.24	04900	30.24	04900
5.00	6	82	44	36.5	36	30.24	05000	30.24	05000
5.10	6	82	44	36.3	36	30.24	05100	30.24	05100
5.20	6	82	44	36.2	36	30.24	05200	30.24	05200
5.30	6	82	44	36.0	36	30.24	05300	30.24	05300
5.40	6	82	44	35.9	36	30.24	05400	30.24	05400
5.50	6	82	44	35.7	36	30.24	05500	30.24	05500
5.55	6	82	44	35.6	36	30.24	05550	30.24	05550
5.60	6	82	44	35.6	36	30.24	05600	30.24	05600
5.65	6	82	44	35.5	36	30.24	05650	30.24	05650
5.70	6	82	44	35.4	36	30.24	05700	30.24	05700
5.80	6	82	44	35.3	36	30.24	05800	30.24	05800
5.90	6	82	44	35.1	36	30.24	05900	30.24	05900
6.00	6	82	44	35.0	36	30.24	06000	30.24	06000
6.10	8	91	53	43.8	36	30.24	06100	30.24	06100
6.20	8	91	53	43.7	36	30.24	06200	30.24	06200
6.30	8	91	53	43.5	36	30.24	06300	30.24	06300
6.40	8	91	53	43.4	36	30.24	06400	30.24	06400
6.50	8	91	53	43.2	36	30.24	06500	30.24	06500
6.60	8	91	53	43.1	36	30.24	06600	30.24	06600
6.70	8	91	53	42.9	36	30.24	06700	30.24	06700
6.80	8	91	53	42.8	36	30.24	06800	30.24	06800
6.90	8	91	53	42.6	36	30.24	06900	30.24	06900
7.00	8	91	53	42.5	36	30.24	07000	30.24	07000
7.10	8	91	53	42.3	36	30.24	07100	30.24	07100
7.20	8	91	53	42.2	36	30.24	07200	30.24	07200
7.30	8	91	53	42.0	36	30.24	07300	30.24	07300
7.40	8	91	53	41.9	36	30.24	07400	30.24	07400
7.50	8	91	53	41.7	36	30.24	07500	30.24	07500
7.55	8	91	53	41.6	36	30.24	07550	30.24	07550
7.60	8	91	53	41.6	36	30.24	07600	30.24	07600
7.65	8	91	53	41.5	36	30.24	07650	30.24	07650
7.70	8	91	53	41.4	36	30.24	07700	30.24	07700
7.80	8	91	53	41.3	36	30.24	07800	30.24	07800
7.90	8	91	53	41.1	36	30.24	07900	30.24	07900
8.00	8	91	53	41.0	36	30.24	08000	30.24	08000

DC _{h7} mm	DCONMS _{h6} mm	OAL mm	LCF mm	LU mm	LS mm	11 710 ...		11 709 ...	
						£ T1/9C	08100	£ T1/9C	08100
8.10	10	103	61	48.8	40	32.65	08100	32.65	08100
8.20	10	103	61	48.7	40	32.65	08200	32.65	08200
8.30	10	103	61	48.5	40	32.65	08300	32.65	08300
8.40	10	103	61	48.4	40	32.65	08400	32.65	08400
8.50	10	103	61	48.2	40	32.65	08500	32.65	08500
8.60	10	103	61	48.1	40	32.65	08600	32.65	08600
8.70	10	103	61	47.9	40	32.65	08700	32.65	08700
8.80	10	103	61	47.8	40	32.65	08800	32.65	08800
8.90	10	103	61	47.6	40	32.65	08900	32.65	08900
9.00	10	103	61	47.5	40	32.65	09000	32.65	09000
9.10	10	103	61	47.3	40	32.65	09100	32.65	09100
9.20	10	103	61	47.2	40	32.65	09200	32.65	09200
9.30	10	103	61	47.0	40	32.65	09300	32.65	09300
9.40	10	103	61	46.9	40	32.65	09400	32.65	09400
9.50	10	103	61	46.7	40	32.65	09500	32.65	09500
9.60	10	103	61	46.6	40	32.65	09600	32.65	09600
9.70	10	103	61	46.4	40	32.65	09700	32.65	09700
9.80	10	103	61	46.3	40	32.65	09800	32.65	09800
9.90	10	103	61	46.1	40	32.65	09900	32.65	09900
10.00	10	103	61	46.0	40	32.65	10000	32.65	10000
10.10	12	118	71	55.8	45	49.59	10100	49.59	10100
10.20	12	118	71	55.7	45	49.59	10200	49.59	10200
10.30	12	118	71	55.5	45	49.59	10300	49.59	10300
10.40	12	118	71	55.4	45	49.59	10400	49.59	10400
10.50	12	118	71	55.2	45	49.59	10500	49.59	10500
10.60	12	118	71	55.1	45	49.59	10600	49.59	10600
10.70	12	118	71	54.9	45	49.59	10700	49.59	10700
10.80	12	118	71	54.8	45	49.59	10800	49.59	10800
10.90	12	118	71	54.6	45	49.59	10900	49.59	10900
11.00	12	118	71	54.5	45	49.59	11000	49.59	11000
11.10	12	118	71	54.3	45	49.59	11100	49.59	11100
11.20	12	118	71	54.2	45	49.59	11200	49.59	11200
11.30	12	118	71	54.0	45	49.59	11300	49.59	11300
11.40	12	118	71	53.9	45	49.59	11400	49.59	11400
11.50	12	118	71	53.7	45	49.59	11500	49.59	11500
11.60	12	118	71	53.6	45	49.59	11600	49.59	11600
11.70	12	118	71	53.4	45	49.59	11700	49.59	11700
11.80	12	118	71	53.3	45	49.59	11800	49.59	11800
11.90	12	118	71	53.1	45	49.59	11900	49.59	11900
12.00	12	118	71	53.0	45	49.59	12000	49.59	12000
12.10	14	124	77	58.8	45	65.31	12100	65.31	12100
12.20	14	124	77	58.7	45	65.31	12200	65.31	12200
12.50	14	124	77	58.2	45	65.31	12500	65.31	12500
12.70	14	124	77	57.9	45	72.23	12700	72.23	12700
12.80	14	124	77	57.8	45	65.31	12800	65.31	12800
13.00	14	124	77	57.5	45	65.31	13000	65.31	13000
13.20	14	124	77	57.2	45	65.31	13200	65.31	13200
13.50	14	124	77	56.7	45	65.31	13500	65.31	13500
13.80	14	124	77	56.3	45	65.31	13800	65.31	13800
14.00	14	124	77	56.0	45	65.31	14000	65.31	14000
14.20	16	133	83	61.7	48	84.66	14200	84.66	14200
14.40	16	133	83	61.4	48	84.66	14400	84.66	14400
14.50	16	133	83	61.2	48	84.66	14500	84.66	14500
14.80	16	133	83	60.8	48	84.66	14800	84.66	14800
15.00	16	133	83	60.5	48	84.66	15000	84.66	15000
15.20	16	133	83	60.2	48	84.66	15200	84.66	15200
15.50	16	133	83	59.7	48	84.66	15500	84.66	15500
15.80	16	133	83	59.3	48	84.66	15800	84.66	15800
16.00	16	133	83	59.0	48	84.66	16000	84.66	16000
16.50	18	143	93	68.2	48	137.88	16500	137.88	16500
17.00	18	143	93	67.5	48	137.88	17000	137.88	17000
17.50	18	143	93	66.7	48	137.88	17500	137.88	17500
18.00	18	143	93	66.0	48	137.88	18000	137.88	18000
18.50	20	153	101	73.2	50	147.55	18500	147.55	18500
18.90	20	153	101	72.6	50	147.55	18900	147.55	18900
19.00	20	153	101	72.5	50	147.55	19000	147.55	19000
19.50	20	153	101	71.7	50	147.55	19500	147.55	19500
20.00	20	153	101	71.0	50	147.55	20000	147.55	20000

Twist drill similar to DIN 338

- ▲ Helix angle 30°
- ▲ Shank Ø h7

≤ 5xD

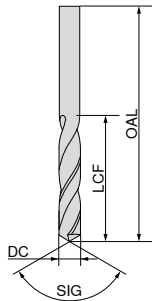

N



SIG 118°
Solid carbide

DC _{h7} mm	OAL mm	LCF mm	£ T3	10 710 ...
0.5	22	6	7.22	005
0.6	24	7	7.22	006
0.7	28	9	7.22	007
0.8	30	10	7.22	008
0.9	32	11	7.22	009
1.0	34	12	7.22	010
1.1	36	14	8.32	011
1.2	38	16	8.32	012
1.3	38	16	8.32	013
1.4	40	18	8.32	014
1.5	40	18	8.32	015
1.6	43	20	8.32	016
1.7	43	20	9.21	017
1.8	46	22	9.78	018
1.9	46	22	9.78	019
2.0	49	24	11.96	020
2.1	49	24	12.29	021
2.2	53	27	12.29	022
2.3	53	27	12.29	023
2.4	57	30	12.29	024
2.5	57	30	14.30	025
2.6	57	30	14.30	026
2.7	61	33	15.71	027
2.8	61	33	16.66	028
2.9	61	33	16.66	029
3.0	61	33	16.61	030
3.1	65	36	16.61	031
3.2	65	36	16.61	032
3.3	65	36	18.44	033
3.4	70	39	18.44	034
3.5	70	39	20.30	035
3.6	70	39	20.30	036
3.7	70	39	20.30	037
3.8	75	43	20.30	038
3.9	75	43	20.30	039
4.0	75	43	24.19	040
4.1	75	43	23.03	041
4.2	75	43	24.95	042
4.3	80	47	26.20	043
4.4	80	47	26.20	044
4.5	80	47	28.08	045
4.6	80	47	28.08	046
4.7	80	47	28.08	047
4.8	86	52	28.60	048
4.9	86	52	28.60	049
5.0	86	52	33.41	050
5.1	86	52	33.41	051
5.2	86	52	33.41	052
5.3	86	52	34.99	053

DC _{h7} mm	OAL mm	LCF mm	£ T3	10 710 ...
5.4	93	57	41.15	054
5.5	93	57	41.15	055
5.6	93	57	41.15	056
5.7	93	57	41.15	057
5.8	93	57	41.15	058
5.9	93	57	41.15	059
6.0	93	57	44.85	060
6.1	101	63	46.97	061
6.2	101	63	46.97	062
6.3	101	63	46.97	063
6.4	101	63	46.97	064
6.5	101	63	53.69	065
6.6	109	69	53.69	066
6.8	109	69	61.37	068
7.0	109	69	61.37	070
7.5	109	69	66.43	075
7.8	117	75	73.25	078
8.0	117	75	73.25	080
8.5	117	75	82.34	085
8.8	125	81	99.82	088
9.0	125	81	99.82	090
9.5	125	81	108.46	095
9.8	133	87	119.77	098
10.0	133	87	119.77	100
10.2	133	87	125.78	102
10.5	133	87	130.68	105
11.0	142	94	152.37	110
11.5	142	94	169.22	115
12.0	151	101	197.38	120
13.0	151	101	214.53	130
14.0	160	108	229.95	140
16.0	178	120	312.30	160

P	○
M	○
K	●
N	●
S	○
H	○
O	○

→ v_c Page 134

WTX – High Performance Drill, DIN 6537

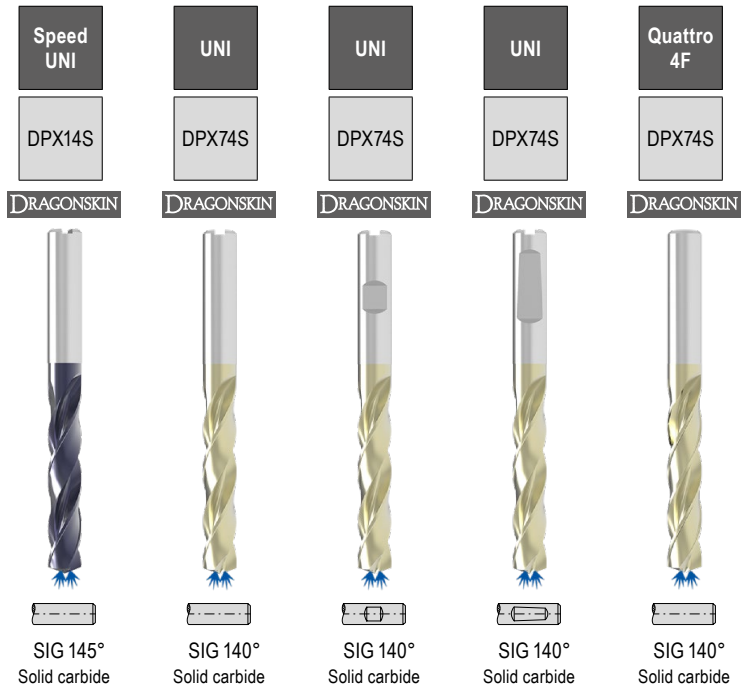
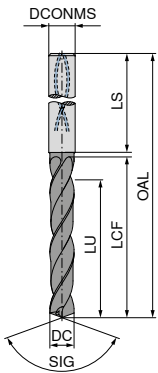
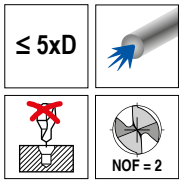

DC _{m7h7} mm	DCONMS _{h6} mm	OAL mm	LCF mm	LU mm	LS mm	10 771 ...		11 786 ...		11 787 ...		11 785 ...		10 735 ...	
						£	Part No.	£	Part No.	£	Part No.	£	Part No.	£	Part No.
3.00	6	66	28	23	36	140.20	03000	71.89	03000	71.89	03000	67.82	03000	140.39	03000
3.10	6	66	28	23	36	140.20	03100	71.89	03100	71.89	03100	67.82	03100	140.39	03100
3.15	6	66	28	23	36			71.89	03150	71.89	03150	67.82	03150		
3.20	6	66	28	23	36	140.20	03200	71.89	03200	71.89	03200	67.82	03200	140.39	03200
3.22	6	66	28	23	36			71.89	03220	71.89	03220	67.82	03220		
3.25	6	66	28	23	36			71.89	03250	71.89	03250	67.82	03250		
3.30	6	66	28	23	36	140.20	03300	71.89	03300	71.89	03300	67.82	03300	140.39	03300
3.40	6	66	28	23	36	140.20	03400	71.89	03400	71.89	03400	67.82	03400	140.39	03400
3.50	6	66	28	23	36	140.20	03500	71.89	03500	71.89	03500	67.82	03500	140.39	03500
3.60	6	66	28	23	36	140.20	03600	71.89	03600	71.89	03600	67.82	03600	140.39	03600
3.70	6	66	28	23	36	140.20	03700	71.89	03700	71.89	03700	67.82	03700	140.39	03700
3.80	6	74	36	29	36	140.20	03800	71.89	03800	71.89	03800	67.82	03800	140.39	03800
3.85	6	74	36	29	36			71.89	03850	71.89	03850	67.82	03850		
3.90	6	74	36	29	36	140.20	03900	71.89	03900	71.89	03900	67.82	03900	140.39	03900
4.00	6	74	36	29	36	140.20	04000	71.89	04000	71.89	04000	67.82	04000	140.39	04000
4.10	6	74	36	29	36	140.20	04100	71.89	04100	71.89	04100	67.82	04100	140.39	04100
4.20	6	74	36	29	36	140.20	04200	71.89	04200	71.89	04200	67.82	04200	140.39	04200
4.25	6	74	36	29	36			71.89	04250	71.89	04250	67.82	04250		
4.30	6	74	36	29	36	140.20	04300	71.89	04300	71.89	04300	67.82	04300	140.39	04300
4.35	6	74	36	29	36			71.89	04350	71.89	04350	67.82	04350		
4.40	6	74	36	29	36	140.20	04400	71.89	04400	71.89	04400	67.82	04400	140.39	04400
4.45	6	74	36	29	36			71.89	04450	71.89	04450	67.82	04450		
4.50	6	74	36	29	36	140.20	04500	71.89	04500	71.89	04500	67.82	04500	140.39	04500
4.60	6	74	36	29	36	140.20	04600	71.89	04600	71.89	04600	67.82	04600	140.39	04600
4.65	6	74	36	29	36	140.20	04650	71.89	04650	71.89	04650	67.82	04650		
4.70	6	74	36	29	36	140.20	04700	71.89	04700	71.89	04700	67.82	04700	140.39	04700
4.80	6	82	44	35	36	140.20	04800	71.89	04800	71.89	04800	67.82	04800	140.39	04800
4.90	6	82	44	35	36	140.20	04900	71.89	04900	71.89	04900	67.82	04900	140.39	04900
4.95	6	82	44	35	36			71.89	04950	71.89	04950	67.82	04950		
5.00	6	82	44	35	36	140.20	05000	71.89	05000	71.89	05000	67.82	05000	140.39	05000
5.05	6	82	44	35	36			71.89	05050	71.89	05050	67.82	05050		
5.10	6	82	44	35	36	140.20	05100	71.89	05100	71.89	05100	67.82	05100	140.39	05100
5.20	6	82	44	35	36	140.20	05200	71.89	05200	71.89	05200	67.82	05200	140.39	05200
5.30	6	82	44	35	36	140.20	05300	71.89	05300	71.89	05300	67.82	05300	140.39	05300

P	•	•	•	•	•
M	•	•	•	•	•
K	•	•	•	•	•
N					
S					
H		○	○	○	○
O					

→ v_c Page 110–120

Ø DC_{m7} for Type UNI and Quattro 4F/ Ø DC_{h7} for Type Speed UNI

WTX – High Performance Drill, DIN 6537

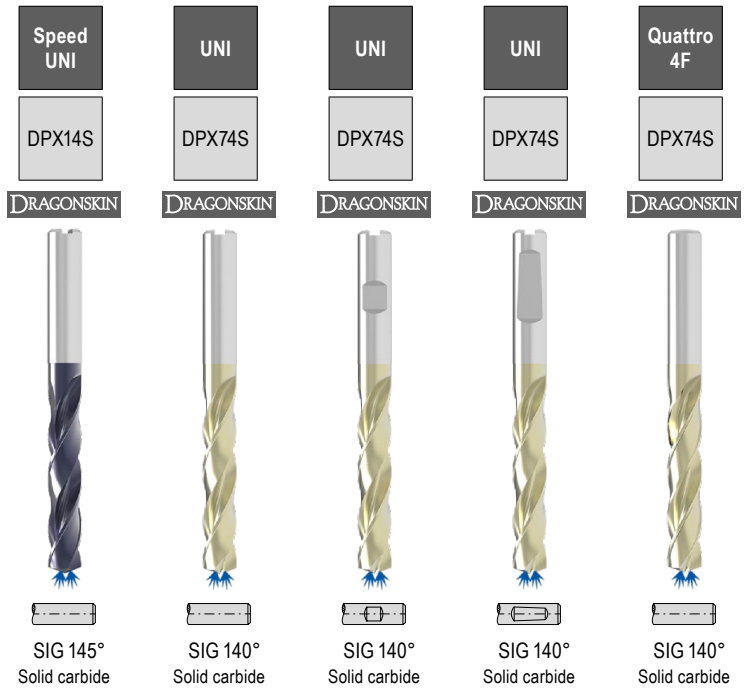
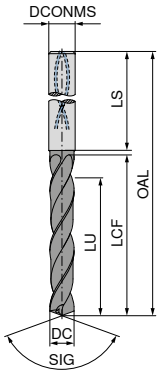
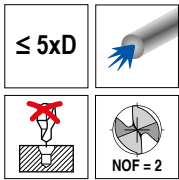

DC _{m7n7} mm	DCONMS _{h6} mm	OAL mm	LCF mm	LU mm	LS mm	10 771 ...		11 786 ...		11 787 ...		11 785 ...		10 735 ...	
						£ T4	05400	£ T7	05400	£ T7	05400	£ T7	05400	£ T4	05400
5.40	6	82	44	35	36	140.20	05400	71.89	05400	71.89	05400	67.82	05400	140.39	05400
5.50	6	82	44	35	36	140.20	05500	71.89	05500	71.89	05500	67.82	05500	140.39	05500
5.55	6	82	44	35	36	140.20	05550	84.16	05550	84.16	05550	67.82	05550		
5.60	6	82	44	35	36	140.20	05600	71.89	05600	71.89	05600	67.82	05600	140.39	05600
5.70	6	82	44	35	36	140.20	05700	71.89	05700	71.89	05700	67.82	05700	140.39	05700
5.75	6	82	44	35	36			71.89	05750	71.89	05750	67.82	05750		
5.80	6	82	44	35	36	140.20	05800	71.89	05800	71.89	05800	67.82	05800	140.39	05800
5.90	6	82	44	35	36	140.20	05900	71.89	05900	71.89	05900	67.82	05900	140.39	05900
5.95	6	82	44	35	36			71.89	05950	71.89	05950	67.82	05950		
6.00	6	82	44	35	36	140.20	06000	71.89	06000	71.89	06000	67.82	06000	140.39	06000
6.10	8	91	53	43	36	156.79	06100	81.04	06100	81.04	06100	77.42	06100	164.17	06100
6.20	8	91	53	43	36	156.79	06200	81.04	06200	81.04	06200	77.42	06200	164.17	06200
6.30	8	91	53	43	36	156.79	06300	81.04	06300	81.04	06300	77.42	06300	164.17	06300
6.40	8	91	53	43	36	156.79	06400	81.04	06400	81.04	06400	77.42	06400	164.17	06400
6.50	8	91	53	43	36	156.79	06500	81.04	06500	81.04	06500	77.42	06500	164.17	06500
6.60	8	91	53	43	36	156.79	06600	81.04	06600	81.04	06600	77.42	06600	164.17	06600
6.70	8	91	53	43	36	156.79	06700	81.04	06700	81.04	06700	77.42	06700	164.17	06700
6.80	8	91	53	43	36	156.79	06800	81.04	06800	81.04	06800	77.42	06800	164.17	06800
6.90	8	91	53	43	36	156.79	06900	81.04	06900	81.04	06900	77.42	06900	164.17	06900
7.00	8	91	53	43	36	156.79	07000	81.04	07000	81.04	07000	77.42	07000	164.17	07000
7.10	8	91	53	43	36	156.79	07100	81.04	07100	81.04	07100	77.42	07100	164.17	07100
7.20	8	91	53	43	36	156.79	07200	81.04	07200	81.04	07200	77.42	07200	164.17	07200
7.30	8	91	53	43	36	156.79	07300	81.04	07300	81.04	07300	77.42	07300	164.17	07300
7.40	8	91	53	43	36	156.79	07400	81.04	07400	81.04	07400	77.42	07400	164.17	07400
7.45	8	91	53	43	36			81.04	07450	81.04	07450	81.04	07450		
7.50	8	91	53	43	36	156.79	07500	81.04	07500	81.04	07500	77.42	07500	164.17	07500
7.60	8	91	53	43	36	156.79	07600	81.04	07600	81.04	07600	77.42	07600	164.17	07600
7.70	8	91	53	43	36	156.79	07700	81.04	07700	81.04	07700	77.42	07700	164.17	07700
7.80	8	91	53	43	36	156.79	07800	81.04	07800	81.04	07800	77.42	07800	164.17	07800
7.90	8	91	53	43	36	156.79	07900	81.04	07900	81.04	07900	77.42	07900	164.17	07900
8.00	8	91	53	43	36	156.79	08000	81.04	08000	81.04	08000	77.42	08000	164.17	08000
8.10	10	103	61	49	40	225.08	08100	93.93	08100	93.93	08100	87.37	08100	204.41	08100
8.20	10	103	61	49	40	225.08	08200	93.93	08200	93.93	08200	87.37	08200	204.41	08200
8.30	10	103	61	49	40	225.08	08300	93.93	08300	93.93	08300	87.37	08300	204.41	08300

P	•	•	•	•	•
M	•	•	•	•	•
K	•	•	•	•	•
N					
S					
H		○	○	○	○
O					

→ v_c Page 110–120

Ø DC_{m7} for Type UNI and Quattro 4F/ Ø DC_{n7} for Type Speed UNI

WTX – High Performance Drill, DIN 6537

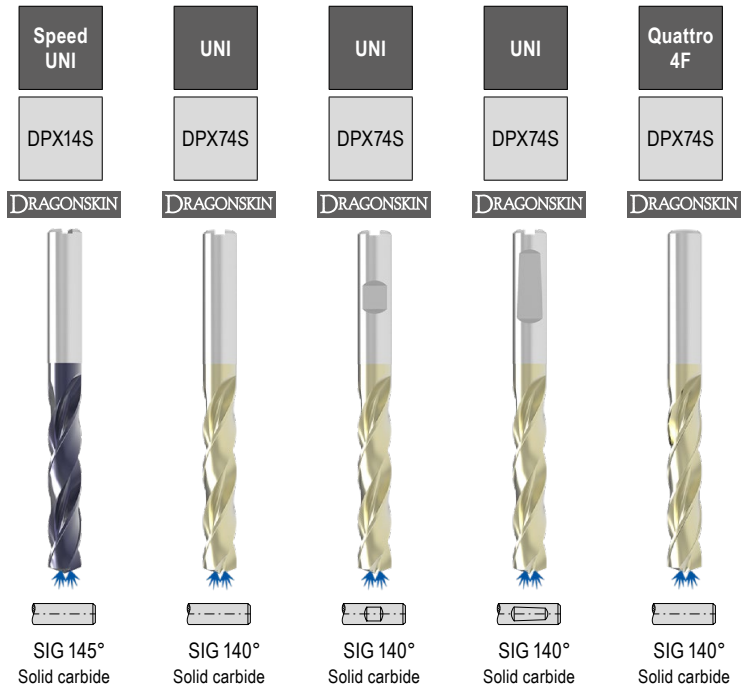
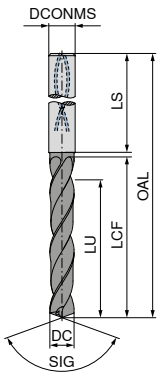
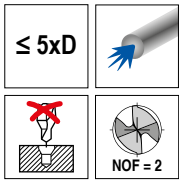

DC _{mTn7} mm	DCONMS _{h6} mm	OAL mm	LCF mm	LU mm	LS mm	10 771 ...		11 786 ...		11 787 ...		11 785 ...		10 735 ...	
						£		£		£		£		£	
8.40	10	103	61	49	40	225.08	08400	93.93	08400	93.93	08400	87.37	08400	204.41	08400
8.50	10	103	61	49	40	225.08	08500	93.93	08500	93.93	08500	87.37	08500	204.41	08500
8.60	10	103	61	49	40	225.08	08600	93.93	08600	93.93	08600	87.37	08600	204.41	08600
8.70	10	103	61	49	40	225.08	08700	93.93	08700	93.93	08700	87.37	08700	204.41	08700
8.80	10	103	61	49	40	225.08	08800	93.93	08800	93.93	08800	87.37	08800	204.41	08800
8.90	10	103	61	49	40	225.08	08900	93.93	08900	93.93	08900	87.37	08900	204.41	08900
9.00	10	103	61	49	40	225.08	09000	93.93	09000	93.93	09000	87.37	09000	204.41	09000
9.10	10	103	61	49	40	225.08	09100	93.93	09100	93.93	09100	87.37	09100	204.41	09100
9.20	10	103	61	49	40	225.08	09200	93.93	09200	93.93	09200	87.37	09200	204.41	09200
9.30	10	103	61	49	40	225.08	09300	93.93	09300	93.93	09300	87.37	09300	204.41	09300
9.35	10	103	61	49	40			93.93	09350	93.93	09350	87.37	09350		
9.40	10	103	61	49	40	225.08	09400	93.93	09400	93.93	09400	87.37	09400	204.41	09400
9.45	10	103	61	49	40			93.93	09450	93.93	09450	87.37	09450		
9.50	10	103	61	49	40	225.08	09500	93.93	09500	93.93	09500	87.37	09500	204.41	09500
9.60	10	103	61	49	40	225.08	09600	93.93	09600	93.93	09600	87.37	09600	204.41	09600
9.70	10	103	61	49	40	225.08	09700	93.93	09700	93.93	09700	87.37	09700	204.41	09700
9.80	10	103	61	49	40	225.08	09800	93.93	09800	93.93	09800	87.37	09800	204.41	09800
9.90	10	103	61	49	40	225.08	09900	93.93	09900	93.93	09900	87.37	09900	204.41	09900
10.00	10	103	61	49	40	225.08	10000	93.93	10000	93.93	10000	87.37	10000	204.41	10000
10.10	12	118	71	56	45	317.28	10100	133.03	10100	133.03	10100	125.80	10100	289.98	10100
10.20	12	118	71	56	45	317.28	10200	133.03	10200	133.03	10200	125.80	10200	289.98	10200
10.30	12	118	71	56	45	317.28	10300	133.03	10300	133.03	10300	125.80	10300	289.98	10300
10.40	12	118	71	56	45	317.28	10400	133.03	10400	133.03	10400	125.80	10400	289.98	10400
10.50	12	118	71	56	45	317.28	10500	133.03	10500	133.03	10500	125.80	10500	289.98	10500
10.55	12	118	71	56	45			133.03	10550	133.03	10550	125.80	10550		
10.60	12	118	71	56	45	317.28	10600	133.03	10600	133.03	10600	125.80	10600	289.98	10600
10.70	12	118	71	56	45	317.28	10700	133.03	10700	133.03	10700	125.80	10700	289.98	10700
10.75	12	118	71	56	45			133.03	10750	133.03	10750	125.80	10750		
10.80	12	118	71	56	45	317.28	10800	133.03	10800	133.03	10800	125.80	10800	289.98	10800
10.90	12	118	71	56	45	317.28	10900	133.03	10900	133.03	10900	125.80	10900	289.98	10900
11.00	12	118	71	56	45	317.28	11000	133.03	11000	133.03	11000	125.80	11000	289.98	11000
11.10	12	118	71	56	45	317.28	11100	133.03	11100	133.03	11100	125.80	11100	289.98	11100
11.20	12	118	71	56	45	317.28	11200	133.03	11200	133.03	11200	125.80	11200	289.98	11200
11.25	12	118	71	56	45			133.03	11250	133.03	11250	125.80	11250		

P	•	•	•	•	•
M	•	•	•	•	•
K	•	•	•	•	•
N					
S					
H		○	○	○	○
O					

WTX – High Performance Drill, DIN 6537

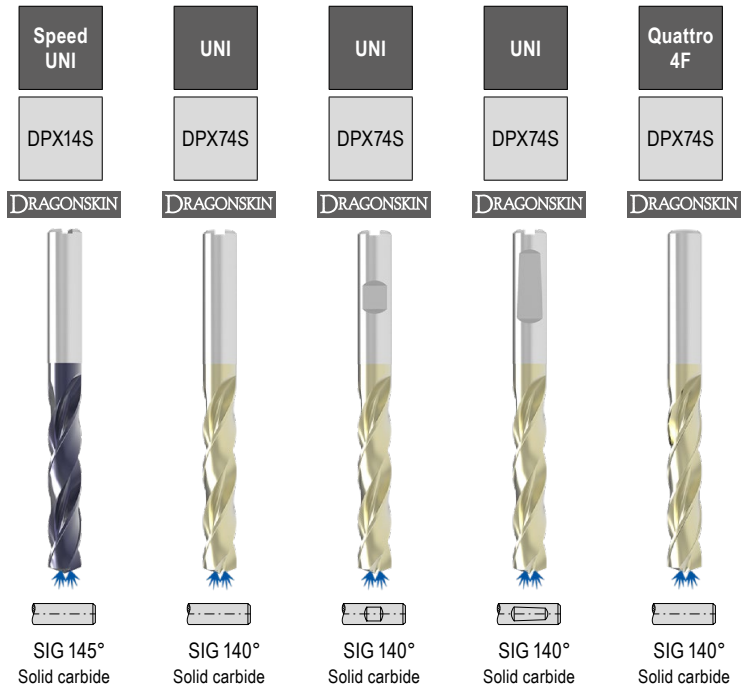
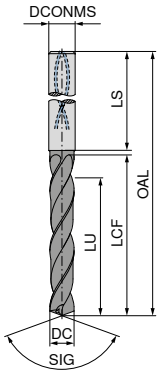
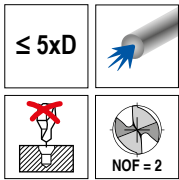

DC _{m7} mm	DCONMS _{h6} mm	OAL mm	LCF mm	LU mm	LS mm	10 771 ...		11 786 ...		11 787 ...		11 785 ...		10 735 ...	
						£ T4	11300	£ T7	11300	£ T7	11300	£ T7	11300	£ T4	11300
11.30	12	118	71	56	45	317.28	11300	133.03	11300	133.03	11300	125.80	11300	289.98	11300
11.35	12	118	71	56	45			133.03	11350	133.03	11350	125.80	11350		
11.40	12	118	71	56	45	317.28	11400	133.03	11400	133.03	11400	125.80	11400	289.98	11400
11.45	12	118	71	56	45			133.03	11450	133.03	11450	125.80	11450		
11.50	12	118	71	56	45	317.28	11500	133.03	11500	133.03	11500	125.80	11500	289.98	11500
11.60	12	118	71	56	45	317.28	11600	133.03	11600	133.03	11600	125.80	11600	289.98	11600
11.70	12	118	71	56	45	317.28	11700	133.03	11700	133.03	11700	125.80	11700	289.98	11700
11.80	12	118	71	56	45	317.28	11800	133.03	11800	133.03	11800	125.80	11800	289.98	11800
11.90	12	118	71	56	45	317.28	11900	133.03	11900	133.03	11900	125.80	11900	289.98	11900
12.00	12	118	71	56	45	317.28	12000	133.03	12000	133.03	12000	125.80	12000	289.98	12000
12.15	14	124	77	60	45			179.34	12150	179.34	12150	166.60	12150		
12.20	14	124	77	60	45	431.65	12200								
12.25	14	124	77	60	45			179.34	12250	179.34	12250	166.60	12250		
12.50	14	124	77	60	45	431.65	12500	179.34	12500	179.34	12500	166.60	12500	392.16	12500
12.55	14	124	77	60	45			179.34	12550	179.34	12550	166.60	12550		
12.70	14	124	77	60	45			179.34	12700	179.34	12700	166.60	12700		
12.80	14	124	77	60	45	431.65	12800	179.34	12800	179.34	12800	166.60	12800	392.16	12800
12.90	14	124	77	60	45			166.60	12900	166.60	12900	166.60	12900		
13.00	14	124	77	60	45	431.65	13000	179.34	13000	179.34	13000	166.60	13000	392.16	13000
13.10	14	124	77	60	45			179.34	13100	179.34	13100	166.60	13100		
13.30	14	124	77	60	45			166.60	13300	166.60	13300	166.60	13300		
13.35	14	124	77	60	45			166.60	13350	166.60	13350	166.60	13350		
13.50	14	124	77	60	45	431.65	13500	179.34	13500	179.34	13500	166.60	13500	392.16	13500
13.70	14	124	77	60	45			179.34	13700	179.34	13700	166.60	13700		
13.80	14	124	77	60	45	431.65	13800	179.34	13800	179.34	13800	166.60	13800	392.16	13800
14.00	14	124	77	60	45	431.65	14000	179.34	14000	179.34	14000	166.60	14000	392.16	14000
14.20	16	133	83	63	48	538.66	14200	208.06	14200	208.06	14200	208.06	14200		
14.50	16	133	83	63	48	538.66	14500	224.18	14500	224.18	14500	208.06	14500	489.59	14500
14.80	16	133	83	63	48	538.66	14800	224.18	14800	224.18	14800	208.06	14800	489.59	14800
15.00	16	133	83	63	48	538.66	15000	224.18	15000	224.18	15000	208.06	15000	489.59	15000
15.10	16	133	83	63	48			224.18	15100	224.18	15100	208.06	15100		
15.20	16	133	83	63	48	538.66	15200								
15.25	16	133	83	63	48			224.18	15250	224.18	15250	208.06	15250		
15.30	16	133	83	63	48			217.96	15300	217.96	15300	208.06	15300		

P	•	•	•	•	•
M	•	•	•	•	•
K	•	•	•	•	•
N					
S					
H		○	○	○	○
O					

→ v_c Page 110–120

Ø DC_{m7} for Type UNI and Quattro 4F/ Ø DC_{h7} for Type Speed UNI

WTX – High Performance Drill, DIN 6537

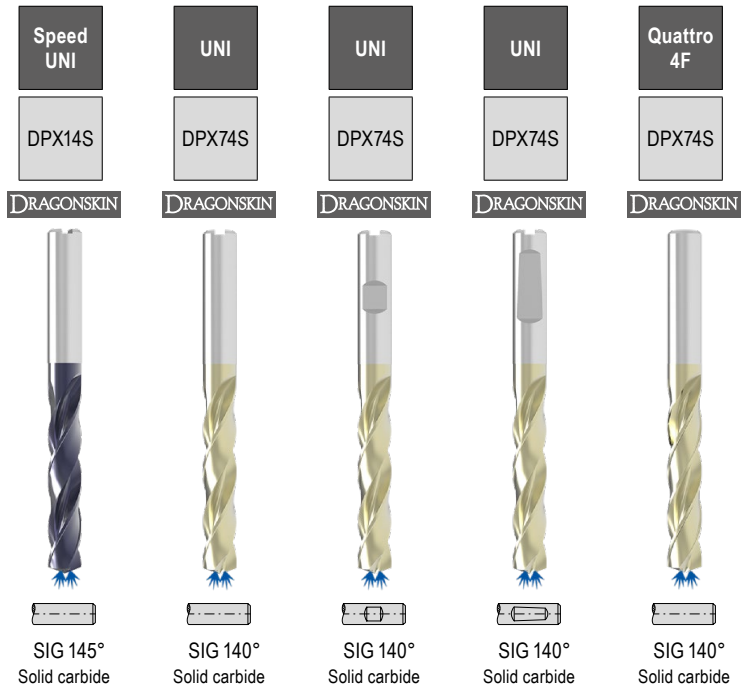
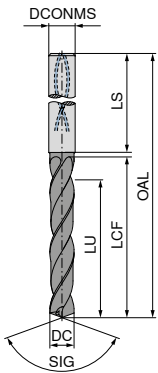
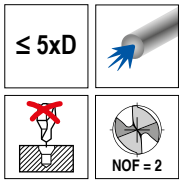

DC _{m7h7} mm	DCONMS _{h6} mm	OAL mm	LCF mm	LU mm	LS mm	10 771 ...		11 786 ...		11 787 ...		11 785 ...		10 735 ...	
						£ T4		£ T7		£ T7		£ T7		£ T4	
15.35	16	133	83	63	48			217.96	15350	217.96	15350	208.06	15350		
15.50	16	133	83	63	48	538.66	15500	224.18	15500	224.18	15500	208.06	15500	489.59	15500
15.60	16	133	83	63	48			224.18	15600	224.18	15600	208.06	15600		
15.80	16	133	83	63	48	538.66	15800	224.18	15800	224.18	15800	208.06	15800	489.59	15800
16.00	16	133	83	63	48	538.66	16000	224.18	16000	224.18	16000	208.06	16000	489.59	16000
16.05	18	143	93	71	48			348.64	16050	348.64	16050	323.57	16050		
16.50	18	143	93	71	48	708.36	16500	348.64	16500	348.64	16500	323.57	16500	643.99	16500
16.80	18	143	93	71	48	708.36	16800	348.64	16800	348.64	16800	323.57	16800	643.99	16800
16.90	18	143	93	71	48			348.64	16900	348.64	16900	323.57	16900		
17.00	18	143	93	71	48	708.36	17000	348.64	17000	348.64	17000	323.57	17000	643.99	17000
17.50	18	143	93	71	48	708.36	17500	348.64	17500	348.64	17500	323.57	17500	643.99	17500
17.60	18	143	93	71	48			348.64	17600	348.64	17600	323.57	17600		
17.80	18	143	93	71	48	708.36	17800	348.64	17800	348.64	17800	323.57	17800	643.99	17800
18.00	18	143	93	71	48	708.36	18000	348.64	18000	348.64	18000	323.57	18000	643.99	18000
18.50	20	153	101	77	50			403.67	18500	403.67	18500	358.24	18500		
18.80	20	153	101	77	50			403.67	18800	403.67	18800	358.24	18800		
18.90	20	153	101	77	50			403.67	18900	403.67	18900	358.24	18900		
19.00	20	153	101	77	50			403.67	19000	403.67	19000	358.24	19000		
19.35	20	153	101	77	50			403.67	19350	403.67	19350	358.24	19350		
19.50	20	153	101	77	50			403.67	19500	403.67	19500	358.24	19500		
19.60	20	153	101	77	50			403.67	19600	403.67	19600	358.24	19600		
19.80	20	153	101	77	50			403.67	19800	403.67	19800	358.24	19800		
20.00	20	153	101	77	50			403.67	20000	403.67	20000	358.24	20000		
20.50	25	200	135	110	56			1,037.51	20500	1,037.51	20500	693.39	20500		
21.00	25	200	135	110	56			1,037.51	21000	1,037.51	21000	693.39	21000		
21.50	25	200	135	110	56			1,037.51	21500	1,037.51	21500	693.39	21500		
22.00	25	200	135	110	56			1,037.51	22000	1,037.51	22000	693.39	22000		
22.50	25	200	140	120	56			1,037.51	22500	1,037.51	22500	693.39	22500		
23.00	25	200	140	120	56			1,037.51	23000	1,037.51	23000	693.39	23000		
23.50	25	200	140	120	56			1,037.51	23500	1,037.51	23500	693.39	23500		
24.00	25	200	140	120	56			1,037.51	24000	1,037.51	24000	693.39	24000		
24.50	25	200	140	120	56			1,037.51	24500	1,037.51	24500	693.39	24500		
25.00	25	200	140	120	56			1,037.51	25000	1,037.51	25000	693.39	25000		

P	•	•	•	•	•
M	•				
K	•	•	•	•	•
N					
S					
H		○	○	○	○
O					

→ v_c Page 110–120

Ø DC_{m7} for Type UNI and Quattro 4F/ Ø DC_{n7} for Type Speed UNI

WTX – High Performance Drill, DIN 6537

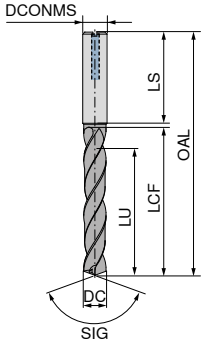
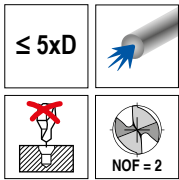

DC _{h7/m7} mm	DCONMS _{h6} mm	OAL mm	LCF mm	LU mm	LS mm
2.50	4	57	21	17	28
2.60	4	57	21	17	28
2.70	4	57	21	17	28
2.80	4	57	21	17	28
2.90	4	57	21	17	28
3.00	6	66	28	23	36
3.10	6	66	28	23	36
3.15	6	66	28	23	36
3.20	6	66	28	23	36
3.22	6	66	28	23	36
3.25	6	66	28	23	36
3.30	6	66	28	23	36
3.40	6	66	28	23	36
3.50	6	66	28	23	36
3.60	6	66	28	23	36
3.70	6	66	28	23	36
3.80	6	74	36	29	36
3.85	6	74	36	29	36
3.90	6	74	36	29	36
4.00	6	74	36	29	36
4.10	6	74	36	29	36
4.20	6	74	36	29	36
4.30	6	74	36	29	36
4.35	6	74	36	29	36
4.40	6	74	36	29	36
4.45	6	74	36	29	36
4.50	6	74	36	29	36
4.60	6	74	36	29	36
4.65	6	74	36	29	36
4.70	6	74	36	29	36
4.80	6	82	44	35	36
4.90	6	82	44	35	36
5.00	6	82	44	35	36
5.10	6	82	44	35	36
5.20	6	82	44	35	36
5.30	6	82	44	35	36
5.40	6	82	44	35	36

10 773 ...		10 745 ...		10 746 ...		10 791 ...	
£	T4	£	T4	£	T4	£	T4
						103.53	02500
						103.53	02600
						103.53	02700
						103.53	02800
						103.53	02900
141.96	030	124.56	030	124.56	030	103.53	03000
141.96	031	124.56	031	124.56	031	103.53	03100
		124.56	831				
141.96	032	124.56	032	124.56	032	103.53	03200
		124.56	832				
		124.56	890				
141.96	033	124.56	033	124.56	033	103.53	03300
141.96	034	124.56	034	124.56	034	103.53	03400
141.96	035	124.56	035	124.56	035	103.53	03500
141.96	036	124.56	036	124.56	036	103.53	03600
141.96	037	124.56	037	124.56	037	103.53	03700
141.96	038	124.56	038	124.56	038	99.90	03800
		124.56	838				
141.96	039	124.56	039	124.56	039	99.90	03900
141.96	040	124.56	040	124.56	040	99.90	04000
141.96	041	124.56	041	124.56	041	99.90	04100
141.96	042	124.56	042	124.56	042	99.90	04200
141.96	043	124.56	043	124.56	043	99.90	04300
		124.56	843				
141.96	044	124.56	044	124.56	044	99.90	04400
		124.56	844				
141.96	045	124.56	045	124.56	045	99.90	04500
141.96	046	124.56	046	124.56	046	99.90	04600
141.96	900	124.56	900				
141.96	047	124.56	047	124.56	047	99.90	04700
141.96	048	124.56	048	124.56	048	100.36	04800
141.96	049	124.56	049	124.56	049	100.36	04900
141.96	050	124.56	050	124.56	050	100.36	05000
141.96	051	124.56	051	124.56	051	100.36	05100
141.96	052	124.56	052	124.56	052	100.36	05200
141.96	053	124.56	053	124.56	053	100.36	05300
141.96	054	124.56	054	124.56	054	100.36	05400

P	●	○	○
M	●	●	●
K	●	○	○
N	○	○	○
S	●	●	●
H			
O			

→ v. Page 116–122

Ø DC_{m7} for Type VA / Ø DC_{n7} for Type Speed VA and AL

WTX – High Performance Drill, DIN 6537

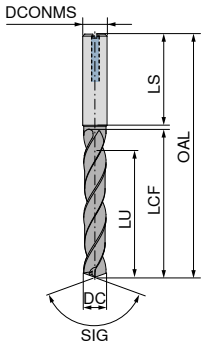
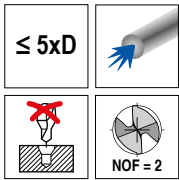

DC _{h7/m7}	DCONMS _{h6}	OAL	LCF	LU	LS
mm	mm	mm	mm	mm	mm
5.50	6	82	44	35	36
5.55	6	82	44	35	36
5.60	6	82	44	35	36
5.70	6	82	44	35	36
5.75	6	82	44	35	36
5.80	6	82	44	35	36
5.90	6	82	44	35	36
5.95	6	82	44	35	36
6.00	6	82	44	35	36
6.10	8	91	53	43	36
6.20	8	91	53	43	36
6.30	8	91	53	43	36
6.40	8	91	53	43	36
6.50	8	91	53	43	36
6.60	8	91	53	43	36
6.70	8	91	53	43	36
6.80	8	91	53	43	36
6.90	8	91	53	43	36
7.00	8	91	53	43	36
7.10	8	91	53	43	36
7.20	8	91	53	43	36
7.30	8	91	53	43	36
7.40	8	91	53	43	36
7.45	8	91	53	43	36
7.50	8	91	53	43	36
7.60	8	91	53	43	36
7.70	8	91	53	43	36
7.80	8	91	53	43	36
7.90	8	91	53	43	36
8.00	8	91	53	43	36
8.10	10	103	61	49	40
8.20	10	103	61	49	40
8.30	10	103	61	49	40
8.40	10	103	61	49	40
8.50	10	103	61	49	40
8.60	10	103	61	49	40
8.70	10	103	61	49	40

10 773 ...		10 745 ...		10 746 ...		10 791 ...	
£	T4	£	T4	£	T4	£	T4
141.96	055	124.56	055	124.56	055	100.36	05500
141.96	902	124.56	056	124.56	056	100.36	05600
141.96	056	124.56	057	124.56	057	100.36	05700
141.96	057	124.56	916	124.56	058	100.36	05800
141.96	058	124.56	058	124.56	058	100.36	05800
141.96	059	124.56	059	124.56	059	100.36	05900
141.96	060	124.56	959	124.56	060	100.36	06000
158.92	061	147.24	061	147.24	061	112.00	06100
158.92	062	147.24	062	147.24	062	112.00	06200
158.92	063	147.24	063	147.24	063	112.00	06300
158.92	064	147.24	064	147.24	064	112.00	06400
158.92	065	147.24	065	147.24	065	112.00	06500
158.92	066	147.24	066	147.24	066	112.00	06600
158.92	067	147.24	067	147.24	067	112.00	06700
158.92	068	147.24	068	147.24	068	112.00	06800
158.92	069	147.24	069	147.24	069	112.00	06900
158.92	070	147.24	070	147.24	070	112.00	07000
158.92	071	147.24	071	147.24	071	112.00	07100
158.92	072	147.24	072	147.24	072	112.00	07200
158.92	073	147.24	073	147.24	073	112.00	07300
158.92	074	147.24	074	147.24	074	112.00	07400
158.92	075	147.24	924	147.24	075	112.00	07500
158.92	076	147.24	076	147.24	076	112.00	07600
158.92	077	147.24	077	147.24	077	112.00	07700
158.92	078	147.24	078	147.24	078	112.00	07800
158.92	079	147.24	079	147.24	079	112.00	07900
229.98	080	185.43	080	185.43	080	112.00	08000
229.98	081	185.43	081	185.43	081	131.16	08100
229.98	082	185.43	082	185.43	082	131.16	08200
229.98	083	185.43	083	185.43	083	131.16	08300
229.98	084	185.43	084	185.43	084	131.16	08400
229.98	085	185.43	085	185.43	085	131.16	08500
229.98	086	185.43	086	185.43	086	131.16	08600
229.98	087	185.43	087	185.43	087	131.16	08700

P	●	○	○
M	●	●	●
K	●	○	○
N	○	○	○
S	●	●	●
H			
O			

→ v_c Page 116–122

Ø DC_{m7} for Type VA / Ø DC_{n7} for Type Speed VA and AL

WTX – High Performance Drill, DIN 6537

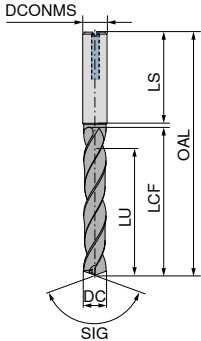
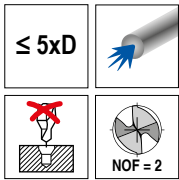

Speed VA	VA	VA	AL
Ti800	Ti700	Ti700	DLC
			DRAGONSKIN



DC _{h7/m7} mm	DCONMS _{h6} mm	OAL mm	LCF mm	LU mm	LS mm	10 773 ...		10 745 ...		10 746 ...		10 791 ...	
						£	T4	£	T4	£	T4	£	T4
8.80	10	103	61	49	40	229.98	088	185.43	088	185.43	088	131.16	08800
8.90	10	103	61	49	40	229.98	089	185.43	089	185.43	089	131.16	08900
9.00	10	103	61	49	40	229.98	090	185.43	090	185.43	090	131.16	09000
9.10	10	103	61	49	40	229.98	091	185.43	091	185.43	091	131.16	09100
9.20	10	103	61	49	40	229.98	092	185.43	092	185.43	092	131.16	09200
9.30	10	103	61	49	40	229.98	093	185.43	093	185.43	093	131.16	09300
9.35	10	103	61	49	40			185.43	930				
9.40	10	103	61	49	40	229.98	094	185.43	094	185.43	094	131.16	09400
9.45	10	103	61	49	40			185.43	994				
9.50	10	103	61	49	40	229.98	095	185.43	095	185.43	095	131.16	09500
9.60	10	103	61	49	40	229.98	096	185.43	096	185.43	096	131.16	09600
9.70	10	103	61	49	40	229.98	097	185.43	097	185.43	097	131.16	09700
9.80	10	103	61	49	40	229.98	098	185.43	098	185.43	098	131.16	09800
9.90	10	103	61	49	40	229.98	099	185.43	099	185.43	099	131.16	09900
10.00	10	103	61	49	40	229.98	100	185.43	100	185.43	100	131.16	10000
10.10	12	118	71	56	45	322.36	101	251.82	101	251.82	101	183.01	10100
10.20	12	118	71	56	45	322.36	102	251.82	102	251.82	102	183.01	10200
10.30	12	118	71	56	45	322.36	103	251.82	103	251.82	103	183.01	10300
10.40	12	118	71	56	45	322.36	104	251.82	104	251.82	104	183.01	10400
10.50	12	118	71	56	45	322.36	105	251.82	105	251.82	105	183.01	10500
10.55	12	118	71	56	45			251.82	932				
10.60	12	118	71	56	45	322.36	106	251.82	106	251.82	106	183.01	10600
10.70	12	118	71	56	45	322.36	107	251.82	107	251.82	107	183.01	10700
10.80	12	118	71	56	45	322.36	108	251.82	108	251.82	108	183.01	10800
10.90	12	118	71	56	45	322.36	109	251.82	109	251.82	109		
11.00	12	118	71	56	45	322.36	110	251.82	110	251.82	110	183.01	11000
11.10	12	118	71	56	45	322.36	111	251.82	111	251.82	111	183.01	11100
11.20	12	118	71	56	45	322.36	112	251.82	112	251.82	112	183.01	11200
11.25	12	118	71	56	45			251.82	912				
11.30	12	118	71	56	45	322.36	113	251.82	113	251.82	113	183.01	11300
11.35	12	118	71	56	45			251.82	913				
11.40	12	118	71	56	45	322.36	114	251.82	114	251.82	114	183.01	11400
11.45	12	118	71	56	45			251.82	914				
11.50	12	118	71	56	45	322.36	115	251.82	115	251.82	115	183.01	11500
11.60	12	118	71	56	45	322.36	116	251.82	116	251.82	116		
11.70	12	118	71	56	45	322.36	117	251.82	117	251.82	117	183.01	11700
11.80	12	118	71	56	45	322.36	118	251.82	118	251.82	118	183.01	11800

P	●	○	○
M	●	●	●
K	●	○	○
N	○	○	○
S	●	●	●
H			
O			

→ v_c Page 116–122

Ø DC_{m7} for Type VA / Ø DC_{h7} for Type Speed VA and AL

WTX – High Performance Drill, DIN 6537

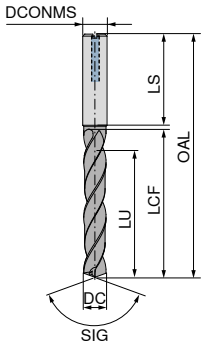
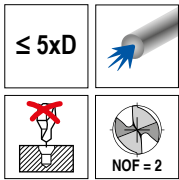

DC _{h7/m7} mm	DCONMS _{h6} mm	OAL mm	LCF mm	LU mm	LS mm	10 773 ...		10 745 ...		10 746 ...		10 791 ...	
						£	T4	£	T4	£	T4	£	T4
11.90	12	118	71	56	45	322.36	119	251.82	119	251.82	119		
12.00	12	118	71	56	45	322.36	120	251.82	120	251.82	120	183.01	12000
12.15	14	124	77	60	45			347.01	921				
12.20	14	124	77	60	45	437.37	12200					254.02	12200
12.50	14	124	77	60	45	437.37	125	347.01	125	347.01	125	254.02	12500
12.55	14	124	77	60	45			347.01	925				
12.60	14	124	77	60	45							254.02	12600
12.80	14	124	77	60	45	437.37	128	347.01	128	347.01	128	254.02	12800
13.00	14	124	77	60	45	437.37	130	347.01	130	347.01	130	254.02	13000
13.35	14	124	77	60	45			347.01	933				
13.50	14	124	77	60	45	437.37	135	347.01	135	347.01	135	254.02	13500
13.80	14	124	77	60	45	437.37	138	347.01	138	347.01	138	254.02	13800
14.00	14	124	77	60	45	437.37	140	347.01	140	347.01	140	254.02	14000
14.20	16	133	83	63	48							310.62	14200
14.50	16	133	83	63	48	546.71	145	437.18	145	437.18	145	310.62	14500
14.80	16	133	83	63	48	546.71	148	437.18	148	437.18	148	310.62	14800
15.00	16	133	83	63	48	546.71	150	437.18	150	437.18	150	310.62	15000
15.20	16	133	83	63	48							310.62	15200
15.35	16	133	83	63	48			437.18	953				
15.50	16	133	83	63	48	546.71	155	437.18	155	437.18	155	310.62	15500
15.80	16	133	83	63	48	546.71	158	437.18	158	437.18	158	310.62	15800
16.00	16	133	83	63	48	546.71	160	437.18	160	437.18	160	310.62	16000
16.05	18	143	93	71	48			603.58	960				
16.50	18	143	93	71	48	720.16	165	603.58	165	603.58	165	431.27	16500
16.80	18	143	93	71	48	720.16	168	603.58	168	603.58	168		
17.00	18	143	93	71	48	720.16	170	603.58	170	603.58	170	431.27	17000
17.50	18	143	93	71	48	720.16	175	603.58	175	603.58	175	431.27	17500
17.80	18	143	93	71	48	720.16	178	603.58	178	603.58	178		
18.00	18	143	93	71	48	720.16	180	603.58	180	603.58	180	431.27	18000
18.50	20	153	101	77	50	931.30	185	715.19	185	715.19	185	532.56	18500
18.80	20	153	101	77	50	931.30	188	715.19	188	715.19	188		
19.00	20	153	101	77	50	931.30	190	715.19	190	715.19	190	532.56	19000
19.35	20	153	101	77	50			715.19	993				
19.50	20	153	101	77	50	931.30	195	715.19	195	715.19	195	532.56	19500
19.80	20	153	101	77	50	931.30	198	715.19	198	715.19	198		
20.00	20	153	101	77	50	931.30	200	715.19	200	715.19	200	532.56	20000

P	●	○	○
M	●	●	●
K	●	○	○
N	○	○	○
S	●	●	●
H			
O			

→ v_c Page 116–122

Ø DC_{m7} for Type VA / Ø DC_{h7} for Type Speed VA and AL

High Performance Drill, DIN 6537

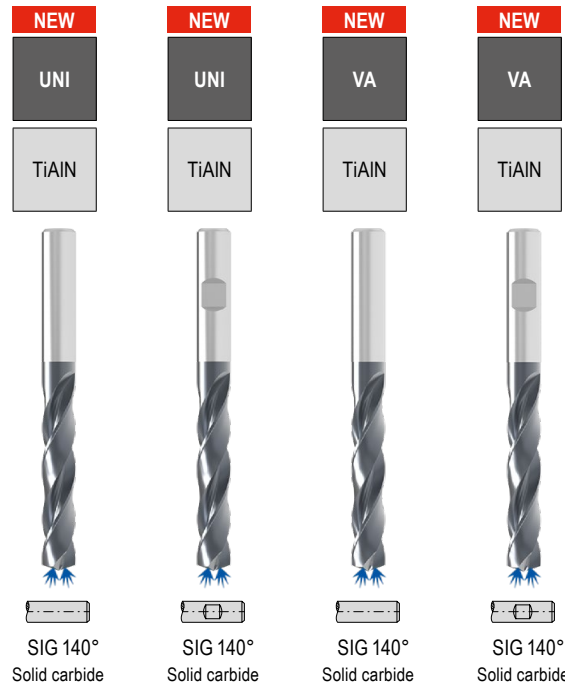
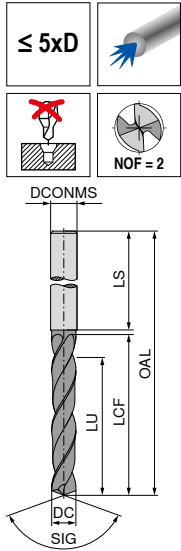

DC _{m7/h7} mm	DCONMS _{h6} mm	OAL mm	LCF mm	LU mm	LS mm
1.00	4	55	8	6.5	28
1.10	4	55	12	10.3	28
1.20	4	55	12	10.2	28
1.30	4	55	12	10.0	28
1.40	4	55	12	9.9	28
1.50	4	55	12	9.7	28
1.60	4	55	16	13.6	28
1.70	4	55	16	13.4	28
1.80	4	55	16	13.3	28
1.90	4	55	16	13.1	28
2.00	4	57	21	18.0	28
2.10	4	57	21	17.8	28
2.20	4	57	21	17.7	28
2.30	4	57	21	17.5	28
2.40	4	57	21	17.4	28
2.50	4	57	21	17.2	28
2.60	4	57	21	17.1	28
2.70	4	57	21	16.9	28
2.80	4	57	21	16.8	28
2.90	4	57	21	16.6	28
3.00	6	66	28	23.5	36
3.10	6	66	28	23.3	36
3.20	6	66	28	23.2	36
3.25	6	66	28	23.1	36
3.30	6	66	28	23.0	36
3.40	6	66	28	22.9	36
3.50	6	66	28	22.7	36
3.60	6	66	28	22.6	36
3.70	6	66	28	22.4	36
3.80	6	74	36	30.3	36
3.85	6	74	36	30.2	36
3.90	6	74	36	30.1	36
4.00	6	74	36	30.0	36
4.10	6	74	36	29.8	36
4.20	6	74	36	29.7	36
4.30	6	74	36	29.5	36
4.40	6	74	36	29.4	36
4.50	6	74	36	29.2	36
4.60	6	74	36	29.1	36
4.65	6	74	36	29.0	36
4.70	6	74	36	28.9	36
4.80	6	82	44	36.8	36
4.90	6	82	44	36.6	36

11 702 ...		11 703 ...		11 715 ...		11 716 ...	
£	T1/9C	£	T1/9C	£	T1/9C	£	T1/9C
36.28	01000			43.04	01000		
36.28	01100			43.04	01100		
36.28	01200			43.04	01200		
36.28	01300			43.04	01300		
36.28	01400			43.04	01400		
36.28	01500			43.04	01500		
36.28	01600			43.04	01600		
36.28	01700			43.04	01700		
36.28	01800			43.04	01800		
36.28	01900			43.04	01900		
36.28	02000			43.04	02000		
36.28	02100			43.04	02100		
36.28	02200			43.04	02200		
36.28	02300			43.04	02300		
36.28	02400			43.04	02400		
36.28	02500			43.04	02500		
36.28	02600			43.04	02600		
36.28	02700			43.04	02700		
36.28	02800			43.04	02800		
36.28	02900			43.04	02900		
36.28	03000	36.28	03000	42.34	03000	42.34	03000
36.28	03100	36.28	03100	42.34	03100	42.34	03100
36.28	03200	36.28	03200	42.34	03200	42.34	03200
36.28	03250	36.28	03250				
36.28	03300	36.28	03300	42.34	03300	42.34	03300
36.28	03400	36.28	03400	42.34	03400	42.34	03400
36.28	03500	36.28	03500	42.34	03500	42.34	03500
36.28	03600	36.28	03600	42.34	03600	42.34	03600
36.28	03700	36.28	03700	42.34	03700	42.34	03700
36.28	03800	36.28	03800	42.34	03800	42.34	03800
36.28	03850	36.28	03850				
36.28	03900	36.28	03900	42.34	03900	42.34	03900
36.28	04000	36.28	04000	42.34	04000	42.34	04000
36.28	04100	36.28	04100	42.34	04100	42.34	04100
36.28	04200	36.28	04200	42.34	04200	42.34	04200
36.28	04300	36.28	04300	42.34	04300	42.34	04300
36.28	04400	36.28	04400	42.34	04400	42.34	04400
36.28	04500	36.28	04500	42.34	04500	42.34	04500
36.28	04600	36.28	04600	42.34	04600	42.34	04600
36.28	04650	36.28	04650				
36.28	04700	36.28	04700	42.34	04700	42.34	04700
36.28	04800	36.28	04800	42.34	04800	42.34	04800
36.28	04900	36.28	04900	42.34	04900	42.34	04900

P	●	●	○	○
M	●	●	●	●
K	●	●		
N	○	○	●	●
S			○	○
H				
O			○	○

→ v_c Page 129+133

Ø DC_{h7} for Type UNI / Ø DC_{m7} for Type VA

High Performance Drill, DIN 6537

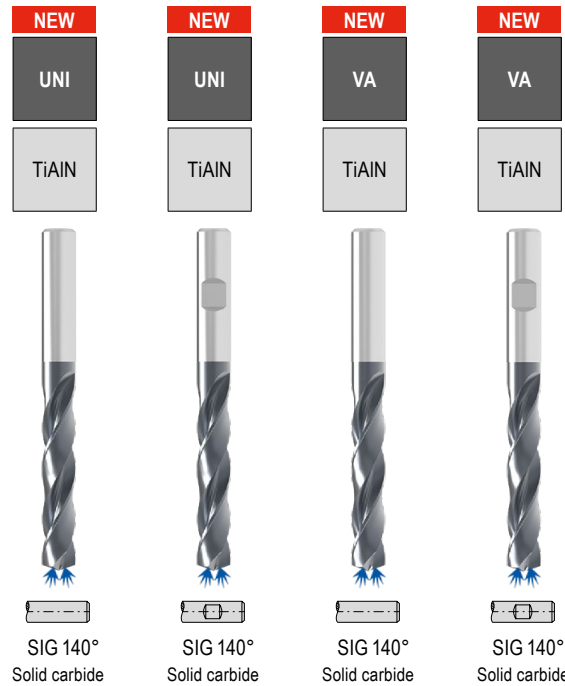
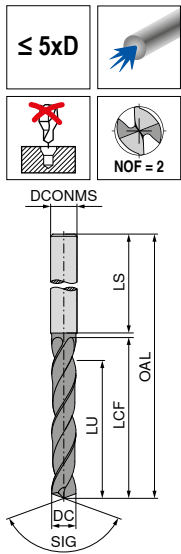

DC _{m7/h7}	DCONMS _{h6}	OAL	LCF	LU	LS
mm	mm	mm	mm	mm	mm
5.00	6	82	44	36.5	36
5.10	6	82	44	36.3	36
5.20	6	82	44	36.2	36
5.30	6	82	44	36.0	36
5.40	6	82	44	35.9	36
5.50	6	82	44	35.7	36
5.55	6	82	44	35.6	36
5.60	6	82	44	35.6	36
5.65	6	82	44	35.5	36
5.70	6	82	44	35.4	36
5.80	6	82	44	35.3	36
5.90	6	82	44	35.1	36
6.00	6	82	44	35.0	36
6.10	8	91	53	43.8	36
6.20	8	91	53	43.7	36
6.30	8	91	53	43.5	36
6.40	8	91	53	43.4	36
6.50	8	91	53	43.2	36
6.60	8	91	53	43.1	36
6.70	8	91	53	42.9	36
6.80	8	91	53	42.8	36
6.90	8	91	53	42.6	36
7.00	8	91	53	42.5	36
7.10	8	91	53	42.3	36
7.20	8	91	53	42.2	36
7.30	8	91	53	42.0	36
7.40	8	91	53	41.9	36
7.45	8	91	53	41.8	36
7.50	8	91	53	41.7	36
7.55	8	91	53	41.6	36
7.60	8	91	53	41.6	36
7.65	8	91	53	41.5	36
7.70	8	91	53	41.4	36
7.80	8	91	53	41.3	36
7.90	8	91	53	41.1	36
8.00	8	91	53	41.0	36
8.10	10	103	61	48.8	40
8.20	10	103	61	48.7	40
8.30	10	103	61	48.5	40
8.40	10	103	61	48.4	40
8.50	10	103	61	48.2	40
8.60	10	103	61	48.1	40
8.70	10	103	61	47.9	40

11 702 ...		11 703 ...		11 715 ...		11 716 ...	
£		£		£		£	
T1/9C		T1/9C		T1/9C		T1/9C	
36.28	05000	36.28	05000	42.34	05000	42.34	05000
36.28	05100	36.28	05100	42.34	05100	42.34	05100
36.28	05200	36.28	05200	42.34	05200	42.34	05200
36.28	05300	36.28	05300	42.34	05300	42.34	05300
36.28	05400	36.28	05400	42.34	05400	42.34	05400
36.28	05500	36.28	05500	42.34	05500	42.34	05500
36.28	05600	36.28	05600	42.34	05600	42.34	05600
36.28	05650	36.28	05650				
36.28	05700	36.28	05700	42.34	05700	42.34	05700
36.28	05800	36.28	05800	42.34	05800	42.34	05800
36.28	05900	36.28	05900	42.34	05900	42.34	05900
36.28	06000	36.28	06000	42.34	06000	42.34	06000
41.12	06100	41.12	06100	48.65	06100	48.65	06100
41.12	06200	41.12	06200	48.65	06200	48.65	06200
41.12	06300	41.12	06300	48.65	06300	48.65	06300
41.12	06400	41.12	06400	48.65	06400	48.65	06400
41.12	06500	41.12	06500	48.65	06500	48.65	06500
41.12	06600	41.12	06600	48.65	06600	48.65	06600
41.12	06700	41.12	06700	48.65	06700	48.65	06700
41.12	06800	41.12	06800	48.65	06800	48.65	06800
41.12	06900	41.12	06900	48.65	06900	48.65	06900
41.12	07000	41.12	07000	48.65	07000	48.65	07000
41.12	07100	41.12	07100	48.65	07100	48.65	07100
41.12	07200	41.12	07200	48.65	07200	48.65	07200
41.12	07300	41.12	07300	48.65	07300	48.65	07300
41.12	07400	41.12	07400	48.65	07400	48.65	07400
41.12	07500	41.12	07500	48.65	07500	48.65	07500
41.12	07550	41.12	07550	48.65	07550	48.65	07550
41.12	07600	41.12	07600	48.65	07600	48.65	07600
41.12	07650	41.12	07650				
41.12	07700	41.12	07700	48.65	07700	48.65	07700
41.12	07800	41.12	07800	48.65	07800	48.65	07800
41.12	07900	41.12	07900	48.65	07900	48.65	07900
41.12	08000	41.12	08000	48.65	08000	48.65	08000
47.17	08100	47.17	08100	55.62	08100	55.62	08100
47.17	08200	47.17	08200	55.62	08200	55.62	08200
47.17	08300	47.17	08300	55.62	08300	55.62	08300
47.17	08400	47.17	08400	55.62	08400	55.62	08400
47.17	08500	47.17	08500	55.62	08500	55.62	08500
47.17	08600	47.17	08600	55.62	08600	55.62	08600
47.17	08700	47.17	08700	55.62	08700	55.62	08700

P	●	●	○	○
M	●	●	●	●
K	●	●		
N	○	○	●	●
S			○	○
H				
O			○	○

→ v_c Page 129+133

Ø DC_{m7} for Type UNI / Ø DC_{m7} for Type VA

High Performance Drill, DIN 6537

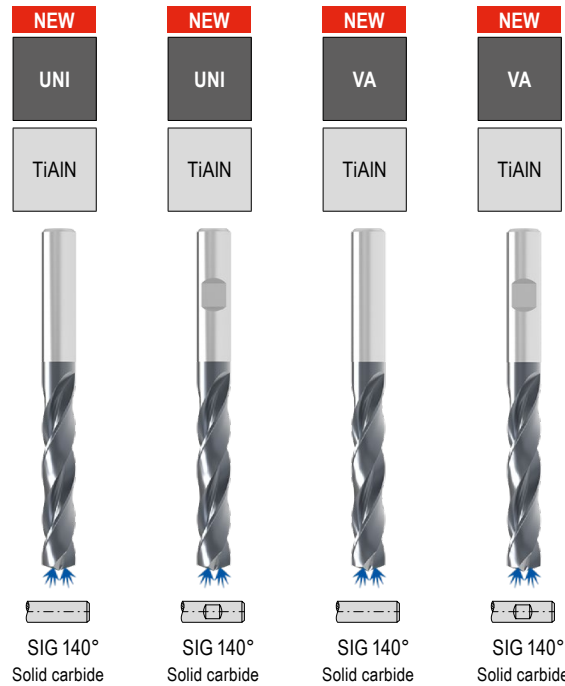
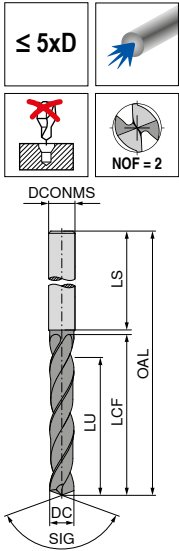

DC m7/h7 mm	DCONMS h6 mm	OAL mm	LCF mm	LU mm	LS mm	11 702 ...		11 703 ...		11 715 ...		11 716 ...	
						£ T1/9C	08800	£ T1/9C	08800	£ T1/9C	08800	£ T1/9C	08800
8.80	10	103	61	47.8	40	47.17	08800	47.17	08900	55.62	08800	55.62	08800
8.90	10	103	61	47.6	40	47.17	08900	47.17	08900	55.62	08900	55.62	08900
9.00	10	103	61	47.5	40	47.17	09000	47.17	09000	55.62	09000	55.62	09000
9.10	10	103	61	47.3	40	47.17	09100	47.17	09100	55.62	09100	55.62	09100
9.20	10	103	61	47.2	40	47.17	09200	47.17	09200	55.62	09200	55.62	09200
9.30	10	103	61	47.0	40	47.17	09300	47.17	09300	55.62	09300	55.62	09300
9.40	10	103	61	46.9	40	47.17	09400	47.17	09400	55.62	09400	55.62	09400
9.50	10	103	61	46.7	40	47.17	09500	47.17	09500	55.62	09500	55.62	09500
9.55	10	103	61	46.6	40	47.17	09550	47.17	09550				
9.60	10	103	61	46.6	40	47.17	09600	47.17	09600	55.62	09600	55.62	09600
9.70	10	103	61	46.4	40	47.17	09700	47.17	09700	55.62	09700	55.62	09700
9.80	10	103	61	46.3	40	47.17	09800	47.17	09800	55.62	09800	55.62	09800
9.90	10	103	61	46.1	40	47.17	09900	47.17	09900	55.62	09900	55.62	09900
10.00	10	103	61	46.0	40	47.17	10000	47.17	10000	55.62	10000	55.62	10000
10.10	12	118	71	55.8	45	70.14	10100	70.14	10100	82.76	10100	82.76	10100
10.20	12	118	71	55.7	45	70.14	10200	70.14	10200	82.76	10200	82.76	10200
10.30	12	118	71	55.5	45	70.14	10300	70.14	10300	82.76	10300	82.76	10300
10.40	12	118	71	55.4	45	70.14	10400	70.14	10400	82.76	10400	82.76	10400
10.50	12	118	71	55.2	45	70.14	10500	70.14	10500	82.76	10500	82.76	10500
10.60	12	118	71	55.1	45	70.14	10600	70.14	10600	82.76	10600	82.76	10600
10.70	12	118	71	54.9	45	70.14	10700	70.14	10700	82.76	10700	82.76	10700
10.80	12	118	71	54.8	45	70.14	10800	70.14	10800	82.76	10800	82.76	10800
10.90	12	118	71	54.6	45	70.14	10900	70.14	10900	82.76	10900	82.76	10900
11.00	12	118	71	54.5	45	70.14	11000	70.14	11000	82.76	11000	82.76	11000
11.10	12	118	71	54.3	45	70.14	11100	70.14	11100	82.76	11100	82.76	11100
11.20	12	118	71	54.2	45	70.14	11200	70.14	11200	82.76	11200	82.76	11200
11.30	12	118	71	54.0	45	70.14	11300	70.14	11300	82.76	11300	82.76	11300
11.40	12	118	71	53.9	45	70.14	11400	70.14	11400	82.76	11400	82.76	11400
11.50	12	118	71	53.7	45	70.14	11500	70.14	11500	82.76	11500	82.76	11500
11.60	12	118	71	53.6	45	70.14	11600	70.14	11600	82.76	11600	82.76	11600
11.70	12	118	71	53.4	45	70.14	11700	70.14	11700	82.76	11700	82.76	11700
11.80	12	118	71	53.3	45	70.14	11800	70.14	11800	82.76	11800	82.76	11800
11.90	12	118	71	53.1	45	70.14	11900	70.14	11900	82.76	11900	82.76	11900
12.00	12	118	71	53.0	45	70.14	12000	70.14	12000	82.76	12000	82.76	12000
12.10	14	124	77	58.8	45	89.50	12100	89.50	12100	105.52	12100	105.52	12100
12.20	14	124	77	58.7	45	89.50	12200	89.50	12200	105.52	12200	105.52	12200
12.40	14	124	77	58.4	45	89.50	12400	89.50	12400	105.52	12400	105.52	12400
12.50	14	124	77	58.2	45	89.50	12500	89.50	12500	105.52	12500	105.52	12500
12.60	14	124	77	58.1	45	89.50	12600	89.50	12600	105.52	12600	105.52	12600
12.70	14	124	77	57.9	45	103.34	12700	103.34	12700	105.52	12700	105.52	12700
12.80	14	124	77	57.8	45	89.50	12800	89.50	12800	105.52	12800	105.52	12800
13.00	14	124	77	57.5	45	89.50	13000	89.50	13000	105.52	13000	105.52	13000
13.10	14	124	77	57.3	45	89.50	13100	89.50	13100	105.52	13100	105.52	13100

P	●	●	○	○
M	●	●	●	●
K	●	●		
N	○	○	●	●
S			○	○
H				
O			○	○

→ v_c Page 129+133

Ø DC_{m7} for Type UNI / Ø DC_{m7} for Type VA

High Performance Drill, DIN 6537

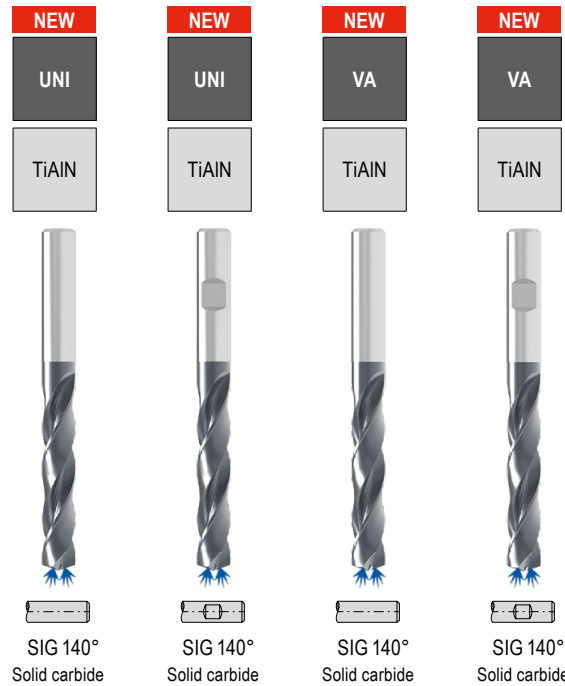
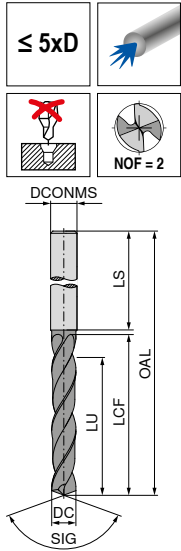

DC _{m7/h7}	DCONMS _{h6}	OAL	LCF	LU	LS
mm	mm	mm	mm	mm	mm
13.20	14	124	77	57.2	45
13.30	14	124	77	57.0	45
13.50	14	124	77	56.7	45
13.70	14	124	77	56.4	45
13.80	14	124	77	56.3	45
14.00	14	124	77	56.0	45
14.20	16	133	83	61.7	48
14.30	16	133	83	61.5	48
14.40	16	133	83	61.4	48
14.50	16	133	83	61.2	48
14.70	16	133	83	60.9	48
14.80	16	133	83	60.8	48
15.00	16	133	83	60.5	48
15.10	16	133	83	60.3	48
15.20	16	133	83	60.2	48
15.25	16	133	83	60.1	48
15.30	16	133	83	60.0	48
15.50	16	133	83	59.7	48
15.70	16	133	83	59.4	48
15.80	16	133	83	59.3	48
16.00	16	133	83	59.0	48
16.20	18	143	93	68.7	48
16.30	18	143	93	68.5	48
16.50	18	143	93	68.2	48
16.80	18	143	93	67.8	48
17.00	18	143	93	67.5	48
17.30	18	143	93	67.0	48
17.50	18	143	93	66.7	48
18.00	18	143	93	66.0	48
18.50	20	153	101	73.2	50
18.90	20	153	101	72.6	50
19.00	20	153	101	72.5	50
19.20	20	153	101	72.2	50
19.30	20	153	101	72.0	50
19.50	20	153	101	71.7	50
19.70	20	153	101	71.4	50
20.00	20	153	101	71.0	50

11 702 ...		11 703 ...		11 715 ...		11 716 ...	
£	13200	£	13200	£	13200	£	13200
T1/9C		T1/9C		T1/9C		T1/9C	
89.50	13200	89.50	13200	105.52	13200	105.52	13200
89.50	13300	89.50	13300	89.50	13300	89.50	13300
89.50	13500	89.50	13500	105.52	13500	105.52	13500
				105.52	13700	105.52	13700
89.50	13800	89.50	13800	105.52	13800	105.52	13800
89.50	14000	89.50	14000	105.52	14000	105.52	14000
114.89	14200	114.89	14200	135.35	14200	135.35	14200
114.89	14300	114.89	14300	135.35	14300	135.35	14300
114.89	14400	114.89	14400	135.35	14400	135.35	14400
114.89	14500	114.89	14500	135.35	14500	135.35	14500
				135.35	14700	135.35	14700
114.89	14800	114.89	14800	135.35	14800	135.35	14800
114.89	15000	114.89	15000	135.35	15000	135.35	15000
114.89	15100	114.89	15100	135.35	15100	135.35	15100
114.89	15200	114.89	15200	135.35	15200	135.35	15200
114.89	15300	114.89	15300	135.35	15300	135.35	15300
114.89	15500	114.89	15500	135.35	15500	135.35	15500
				135.35	15700	135.35	15700
114.89	15800	114.89	15800	135.35	15800	135.35	15800
114.89	16000	114.89	16000	135.35	16000	135.35	16000
176.57	16200	176.57	16200	209.32	16200	209.32	16200
176.57	16300	176.57	16300	209.32	16300	209.32	16300
176.57	16500	176.57	16500	209.32	16500	209.32	16500
176.57	16800	176.57	16800	209.32	16800	209.32	16800
176.57	17000	176.57	17000	209.32	17000	209.32	17000
176.57	17300	176.57	17300	209.32	17300	209.32	17300
176.57	17500	176.57	17500	209.32	17500	209.32	17500
176.57	18000	176.57	18000	209.32	18000	209.32	18000
192.29	18500	192.29	18500	227.70	18500	227.70	18500
192.29	18900	192.29	18900	227.70	18900	227.70	18900
192.29	19000	192.29	19000	227.70	19000	227.70	19000
192.29	19200	192.29	19200	227.70	19200	227.70	19200
192.29	19300	192.29	19300	227.70	19300	227.70	19300
192.29	19500	192.29	19500	227.70	19500	227.70	19500
192.29	19700	192.29	19700	227.70	19700	227.70	19700
192.29	20000	192.29	20000	227.70	20000	227.70	20000

P	●	●	○	○
M	●	●	●	●
K	●	●	●	●
N	○	○	●	●
S	○	○	○	○
H				
O			○	○

→ v_c Page 129+133

Ø DC_{h7} for Type UNI / Ø DC_{m7} for Type VA

WTX – High-performance drill, DIN 6537

▲ Specialist for difficult to machine materials

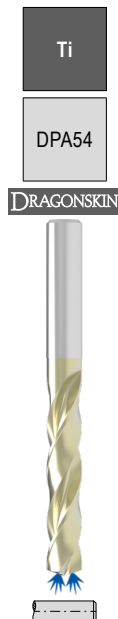
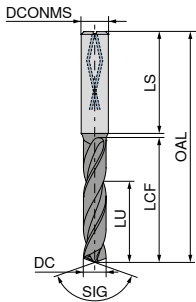
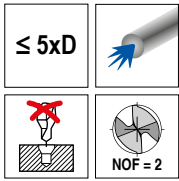

SIG 140°
Solid carbide

10 787 ...

DC _{m7} mm	DCONMS _{h6} mm	OAL mm	LCF mm	LU mm	LS mm	£ T4	
3.00	6	66	28	23	36	91.98	030
3.10	6	66	28	23	36	91.98	031
3.20	6	66	28	23	36	91.98	032
3.30	6	66	28	23	36	91.98	033
3.40	6	66	28	23	36	91.98	034
3.50	6	66	28	23	36	91.98	035
3.60	6	66	28	23	36	91.98	036
3.70	6	66	28	23	36	91.98	037
3.80	6	74	36	29	36	91.98	038
3.90	6	74	36	29	36	91.98	039
3.97	6	74	36	29	36	91.98	900
4.00	6	74	36	29	36	91.98	040
4.10	6	74	36	29	36	91.98	041
4.20	6	74	36	29	36	91.98	042
4.23	6	74	36	29	36	91.98	901
4.30	6	74	36	29	36	91.98	043
4.40	6	74	36	29	36	91.98	044
4.50	6	74	36	29	36	91.98	045
4.60	6	74	36	29	36	91.98	046
4.70	6	74	36	29	36	91.98	047
4.80	6	82	44	35	36	91.98	048
4.90	6	82	44	35	36	91.98	049
5.00	6	82	44	35	36	91.98	050
5.10	6	82	44	35	36	91.98	051
5.20	6	82	44	35	36	91.98	052
5.30	6	82	44	35	36	91.98	053
5.40	6	82	44	35	36	91.98	054
5.50	6	82	44	35	36	91.98	055
5.56	6	82	44	35	36	91.98	902
5.60	6	82	44	35	36	91.98	056
5.70	6	82	44	35	36	91.98	057
5.80	6	82	44	35	36	91.98	058
5.90	6	82	44	35	36	91.98	059
6.00	6	82	44	35	36	91.98	060
6.10	8	91	53	43	36	102.64	061
6.20	8	91	53	43	36	102.64	062
6.30	8	91	53	43	36	102.64	063
6.35	8	91	53	43	36	102.64	903
6.40	8	91	53	43	36	102.64	064
6.50	8	91	53	43	36	102.64	065
6.60	8	91	53	43	36	102.64	066
6.70	8	91	53	43	36	102.64	067
6.80	8	91	53	43	36	102.64	068
6.90	8	91	53	43	36	102.64	069
7.00	8	91	53	43	36	102.64	070
7.10	8	91	53	43	36	102.64	071
7.20	8	91	53	43	36	102.64	072
7.30	8	91	53	43	36	102.64	073
7.40	8	91	53	43	36	102.64	074
7.50	8	91	53	43	36	102.64	075
7.60	8	91	53	43	36	102.64	076

10 787 ...

DC _{m7} mm	DCONMS _{h6} mm	OAL mm	LCF mm	LU mm	LS mm	£ T4	
7.70	8	91	53	43	36	102.64	077
7.80	8	91	53	43	36	102.64	078
7.90	8	91	53	43	36	102.64	079
7.94	8	91	53	43	36	102.64	904
8.00	8	91	53	43	36	102.64	080
8.10	10	103	61	49	40	120.19	081
8.20	10	103	61	49	40	120.19	082
8.30	10	103	61	49	40	120.19	083
8.40	10	103	61	49	40	120.19	084
8.50	10	103	61	49	40	120.19	085
8.60	10	103	61	49	40	120.19	086
8.70	10	103	61	49	40	120.19	087
8.80	10	103	61	49	40	120.19	088
8.90	10	103	61	49	40	120.19	089
9.00	10	103	61	49	40	120.19	090
9.10	10	103	61	49	40	120.19	091
9.20	10	103	61	49	40	120.19	092
9.30	10	103	61	49	40	120.19	093
9.40	10	103	61	49	40	120.19	094
9.50	10	103	61	49	40	120.19	095
9.53	10	103	61	49	40	120.19	905
9.60	10	103	61	49	40	120.19	096
9.70	10	103	61	49	40	120.19	097
9.80	10	103	61	49	40	120.19	098
9.90	10	103	61	49	40	120.19	099
10.00	10	103	61	49	40	120.19	100
10.10	12	118	71	54	45	167.80	101
10.20	12	118	71	54	45	167.80	102
10.30	12	118	71	54	45	167.80	103
10.40	12	118	71	54	45	167.80	104
10.50	12	118	71	54	45	167.80	105
10.60	12	118	71	54	45	167.80	106
10.70	12	118	71	54	45	167.80	107
10.80	12	118	71	54	45	167.80	108
10.90	12	118	71	54	45	167.80	109
11.00	12	118	71	54	45	167.80	110
11.10	12	118	71	54	45	167.80	111
11.11	12	118	71	54	45	167.80	906
11.20	12	118	71	54	45	167.80	112
11.30	12	118	71	54	45	167.80	113
11.40	12	118	71	54	45	167.80	114
11.50	12	118	71	54	45	167.80	115
11.60	12	118	71	54	45	167.80	116
11.70	12	118	71	54	45	167.80	117
11.80	12	118	71	54	45	167.80	118
11.90	12	118	71	54	45	167.80	119
12.00	12	118	71	54	45	167.80	120
12.10	14	124	77	58	45	233.38	121
12.20	14	124	77	58	45	233.38	122
12.30	14	124	77	58	45	233.38	123
12.40	14	124	77	58	45	233.38	124
12.50	14	124	77	58	45	233.38	125
12.60	14	124	77	58	45	233.38	126
12.70	14	124	77	58	45	233.38	907
12.80	14	124	77	58	45	233.38	128
12.90	14	124	77	58	45	233.38	129
13.00	14	124	77	58	45	233.38	130
13.10	14	124	77	58	45	233.38	131
13.20	14	124	77	58	45	233.38	132
13.30	14	124	77	58	45	233.38	133
13.40	14	124	77	58	45	233.38	134
13.50	14	124	77	58	45	233.38	135
13.60	14	124	77	58	45	233.38	136
13.70	14	124	77	58	45	233.38	137
13.80	14	124	77	58	45	233.38	138
13.90	14	124	77	58	45	233.38	139

P	○
M	●
K	
N	
S	●
H	
O	

→ v. Page 109

WTX – High-performance drill, DIN 6537

▲ Specialist for difficult to machine materials

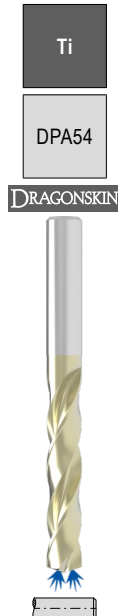
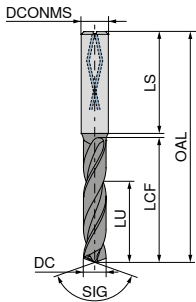
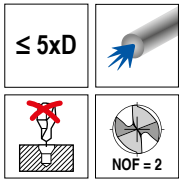

SIG 140°
Solid carbide

10 787 ...

DC _{m7} mm	DCONMS _{h6} mm	OAL mm	LCF mm	LU mm	LS mm	£ T4	
14.0	14	124	77	58	45	233.38	140
14.1	16	133	83	61	48	285.21	141
14.2	16	133	83	61	48	285.21	142
14.3	16	133	83	61	48	285.21	143
14.4	16	133	83	61	48	285.21	144
14.5	16	133	83	61	48	285.21	145
14.6	16	133	83	61	48	285.21	146
14.7	16	133	83	61	48	285.21	147
14.8	16	133	83	61	48	285.21	148
14.9	16	133	83	61	48	285.21	149
15.0	16	133	83	61	48	285.21	150
15.1	16	133	83	61	48	285.21	151
15.2	16	133	83	61	48	285.21	152
15.3	16	133	83	61	48	285.21	153
15.4	16	133	83	61	48	285.21	154
15.5	16	133	83	61	48	285.21	155
15.6	16	133	83	61	48	285.21	156
15.7	16	133	83	61	48	285.21	157
15.8	16	133	83	61	48	285.21	158
15.9	16	133	83	61	48	285.21	159
16.0	16	133	83	61	48	285.21	160
16.1	18	143	93	69	48	285.21	161
16.2	18	143	93	69	48	285.21	162
16.3	18	143	93	69	48	285.21	163
16.4	18	143	93	69	48	285.21	164
16.5	18	143	93	69	48	395.04	165
16.6	18	143	93	69	48	395.04	166
16.7	18	143	93	69	48	395.04	167
16.8	18	143	93	69	48	395.04	168
16.9	18	143	93	69	48	395.04	169
17.0	18	143	93	69	48	395.04	170
17.1	18	143	93	69	48	395.04	171
17.2	18	143	93	69	48	395.04	172
17.3	18	143	93	69	48	395.04	173
17.4	18	143	93	69	48	395.04	174
17.5	18	143	93	69	48	395.04	175
17.6	18	143	93	69	48	395.04	176
17.7	18	143	93	69	48	395.04	177
17.8	18	143	93	69	48	395.04	178
17.9	18	143	93	69	48	395.04	179
18.0	18	143	93	69	48	395.04	180
18.1	20	153	101	75	50	488.07	181
18.2	20	153	101	75	50	488.07	182
18.3	20	153	101	75	50	488.07	183
18.4	20	153	101	75	50	488.07	184
18.5	20	153	101	75	50	488.07	185
18.6	20	153	101	75	50	488.07	186
18.7	20	153	101	75	50	488.07	187
18.8	20	153	101	75	50	488.07	188
18.9	20	153	101	75	50	488.07	189
19.0	20	153	101	75	50	488.07	190

10 787 ...

DC _{m7} mm	DCONMS _{h6} mm	OAL mm	LCF mm	LU mm	LS mm	£ T4	
19.1	20	153	101	75	50	488.07	191
19.2	20	153	101	75	50	488.07	192
19.3	20	153	101	75	50	488.07	193
19.4	20	153	101	75	50	488.07	194
19.5	20	153	101	75	50	488.07	195
19.6	20	153	101	75	50	488.07	196
19.7	20	153	101	75	50	488.07	197
19.8	20	153	101	75	50	488.07	198
19.9	20	153	101	75	50	488.07	199
20.0	20	153	101	75	50	488.07	200

P	○
M	●
K	
N	
S	●
H	
O	

→ v. Page 109

WTX – High Performance Drill, DIN 6537

▲ universal application
▲ four guidance lands

▲ polished chip flutes
▲ Type ALU 5xD on request

▲ PL = corner chamfers

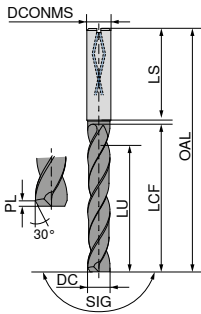
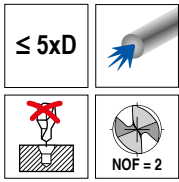

180
Ti800



SIG 180°
Solid carbide

10 721 ...

DC _{m7} mm	DCONMS _{h6} mm	OAL mm	LCF mm	LU mm	LS mm	PL mm	£ T4	
3.00	6	66	28	23	36	0.15	115.27	030
3.10	6	66	28	23	36	0.16	115.27	031
3.20	6	66	28	23	36	0.16	115.27	032
3.30	6	66	28	23	36	0.17	115.27	033
3.40	6	66	28	23	36	0.17	115.27	034
3.50	6	66	28	23	36	0.18	115.27	035
3.60	6	66	28	23	36	0.18	115.27	036
3.70	6	66	28	23	36	0.19	115.27	037
3.80	6	74	36	29	36	0.19	115.27	038
3.90	6	74	36	29	36	0.20	115.27	039
4.00	6	74	36	29	36	0.20	115.27	040
4.10	6	74	36	29	36	0.21	115.27	041
4.20	6	74	36	29	36	0.21	115.27	042
4.30	6	74	36	29	36	0.22	115.27	043
4.40	6	74	36	29	36	0.22	115.27	044
4.50	6	74	36	29	36	0.23	115.27	045
4.60	6	74	36	29	36	0.23	115.27	046
4.65	6	74	36	29	36	0.23	115.27	900
4.70	6	74	36	29	36	0.24	115.27	047
4.80	6	82	44	35	36	0.24	115.27	048
4.90	6	82	44	35	36	0.25	115.27	049
5.00	6	82	44	35	36	0.25	115.27	050
5.10	6	82	44	35	36	0.26	115.27	051
5.20	6	82	44	35	36	0.26	115.27	052
5.30	6	82	44	35	36	0.27	115.27	053
5.40	6	82	44	35	36	0.27	115.27	054
5.50	6	82	44	35	36	0.28	115.27	055
5.55	6	82	44	35	36	0.28	115.27	902
5.60	6	82	44	35	36	0.28	115.27	056
5.70	6	82	44	35	36	0.29	115.27	057
5.80	6	82	44	35	36	0.29	115.27	058
5.90	6	82	44	35	36	0.30	115.27	059
6.00	6	82	44	35	36	0.30	115.27	060
6.10	8	91	53	43	36	0.31	128.97	061
6.20	8	91	53	43	36	0.31	128.97	062
6.30	8	91	53	43	36	0.32	128.97	063
6.40	8	91	53	43	36	0.32	128.97	064
6.50	8	91	53	43	36	0.33	128.97	065
6.60	8	91	53	43	36	0.33	128.97	066
6.70	8	91	53	43	36	0.34	128.97	067
6.80	8	91	53	43	36	0.34	128.97	068
6.90	8	91	53	43	36	0.35	128.97	069
7.00	8	91	53	43	36	0.35	128.97	070
7.10	8	91	53	43	36	0.36	128.97	071
7.20	8	91	53	43	36	0.36	128.97	072
7.30	8	91	53	43	36	0.37	128.97	073
7.40	8	91	53	43	36	0.37	128.97	074
7.50	8	91	53	43	36	0.38	128.97	075
7.60	8	91	53	43	36	0.38	128.97	076
7.70	8	91	53	43	36	0.39	128.97	077
7.80	8	91	53	43	36	0.39	128.97	078
7.90	8	91	53	43	36	0.40	128.97	079
8.00	8	91	53	43	36	0.40	128.97	080
8.10	10	103	61	49	40	0.41	186.42	081

DC _{m7} mm	DCONMS _{h6} mm	OAL mm	LCF mm	LU mm	LS mm	PL mm	£ T4	
8.20	10	103	61	49	40	0.41	186.42	082
8.30	10	103	61	49	40	0.42	186.42	083
8.40	10	103	61	49	40	0.42	186.42	084
8.50	10	103	61	49	40	0.43	186.42	085
8.60	10	103	61	49	40	0.43	186.42	086
8.70	10	103	61	49	40	0.44	186.42	087
8.80	10	103	61	49	40	0.44	186.42	088
8.90	10	103	61	49	40	0.45	186.42	089
9.00	10	103	61	49	40	0.45	186.42	090
9.10	10	103	61	49	40	0.46	186.42	091
9.20	10	103	61	49	40	0.46	186.42	092
9.30	10	103	61	49	40	0.47	186.42	093
9.40	10	103	61	49	40	0.47	186.42	094
9.50	10	103	61	49	40	0.48	186.42	095
9.60	10	103	61	49	40	0.48	186.42	096
9.70	10	103	61	49	40	0.49	186.42	097
9.80	10	103	61	49	40	0.49	186.42	098
9.90	10	103	61	49	40	0.50	186.42	099
10.00	10	103	61	49	40	0.50	186.42	100
10.10	12	116	69	54	45	0.51	260.72	101
10.20	12	116	69	54	45	0.51	260.72	102
10.30	12	116	69	54	45	0.52	260.72	103
10.40	12	116	69	54	45	0.52	260.72	104
10.50	12	116	69	54	45	0.53	260.72	105
10.60	12	116	69	54	45	0.53	260.72	106
10.70	12	116	69	54	45	0.54	260.72	107
10.80	12	116	69	54	45	0.54	260.72	108
10.90	12	116	69	54	45	0.55	260.72	109
11.00	12	116	69	54	45	0.55	260.72	110
11.10	12	116	69	54	45	0.56	260.72	111
11.20	12	116	69	54	45	0.56	260.72	112
11.30	12	116	69	54	45	0.57	260.72	113
11.40	12	116	69	54	45	0.57	260.72	114
11.50	12	116	69	54	45	0.58	260.72	115
11.60	12	116	69	54	45	0.58	260.72	116
11.70	12	116	69	54	45	0.59	260.72	117
11.80	12	116	69	54	45	0.59	260.72	118
11.90	12	116	69	54	45	0.60	260.72	119
12.00	12	116	69	54	45	0.60	260.72	120
12.50	14	122	75	58	45	0.63	354.53	125
12.80	14	122	75	58	45	0.64	354.53	128
13.00	14	122	75	58	45	0.65	354.53	130
13.50	14	122	75	58	45	0.68	354.53	135
13.80	14	122	75	58	45	0.69	354.53	138
14.00	14	122	75	58	45	0.70	354.53	140
14.50	16	131	81	61	48	0.73	442.56	145
14.80	16	131	81	61	48	0.74	442.56	148
15.00	16	131	81	61	48	0.75	442.56	150
15.50	16	131	81	61	48	0.78	442.56	155
15.80	16	131	81	61	48	0.79	442.56	158
16.00	16	131	81	61	48	0.80	442.56	160
16.50	18	141	91	69	48	0.83	583.46	165
16.80	18	141	91	69	48	0.84	583.46	168
17.00	18	141	91	69	48	0.85	583.46	170
17.50	18	141	91	69	48	0.88	583.46	175
17.80	18	141	91	69	48	0.89	583.46	178
18.00	18	141	91	69	48	0.90	583.46	180
18.50	20	151	99	75	50	0.93	754.57	185
18.80	20	151	99	75	50	0.94	754.57	188
19.00	20	151	99	75	50	0.95	754.57	190
19.50	20	151	99	75	50	0.98	754.57	195
19.80	20	151	99	75	50	0.99	754.57	198
20.00	20	151	99	75	50	1.00	754.57	200

P	●
M	●
K	●
N	●
S	●
H	●
O	●

→ v. Page 127

WTX – High Feed Drill, factory standard

- ▲ Three fluted high-feed drill
- ▲ Universal application

- ▲ High positioning accuracy
- ▲ Suitable for difficult drilling applications

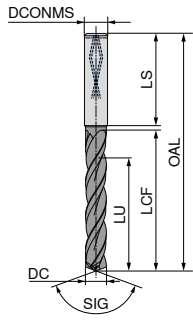
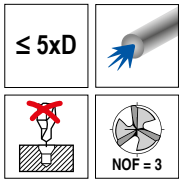

Feed UNI
DPX74S
DRAGONSKIN



SIG 140°
Solid carbide

10 789 ...

DC _{m7} mm	DCONMS _{h6} mm	OAL mm	LCF mm	LU mm	LS mm	£ T4
4.00	6	74	36	29	36	114.32 04000
4.10	6	74	36	29	36	114.32 04100
4.20	6	74	36	29	36	114.32 04200
4.30	6	74	36	29	36	114.32 04300
4.40	6	74	36	29	36	114.32 04400
4.50	6	74	36	29	36	114.32 04500
4.60	6	74	36	29	36	114.32 04600
4.70	6	74	36	29	36	114.32 04700
4.80	6	82	44	35	36	114.32 04800
4.90	6	82	44	35	36	114.32 04900
5.00	6	82	44	35	36	114.32 05000
5.10	6	82	44	35	36	114.32 05100
5.20	6	82	44	35	36	114.32 05200
5.30	6	82	44	35	36	114.32 05300
5.40	6	82	44	35	36	114.32 05400
5.50	6	82	44	35	36	114.32 05500
5.55	6	82	44	35	36	114.32 05550
5.60	6	82	44	35	36	114.32 05600
5.70	6	82	44	35	36	114.32 05700
5.80	6	82	44	35	36	114.32 05800
5.90	6	82	44	35	36	114.32 05900
6.00	6	82	44	35	36	114.32 06000
6.10	8	91	53	43	36	127.95 06100
6.20	8	91	53	43	36	127.95 06200
6.30	8	91	53	43	36	127.95 06300
6.40	8	91	53	43	36	127.95 06400
6.50	8	91	53	43	36	127.95 06500
6.60	8	91	53	43	36	127.95 06600
6.70	8	91	53	43	36	127.95 06700
6.80	8	91	53	43	36	127.95 06800
6.90	8	91	53	43	36	127.95 06900
7.00	8	91	53	43	36	127.95 07000
7.10	8	91	53	43	36	127.95 07100
7.20	8	91	53	43	36	127.95 07200
7.30	8	91	53	43	36	127.95 07300
7.40	8	91	53	43	36	127.95 07400
7.50	8	91	53	43	36	127.95 07500
7.60	8	91	53	43	36	127.95 07600
7.70	8	91	53	43	36	127.95 07700
7.80	8	91	53	43	36	127.95 07800
7.90	8	91	53	43	36	127.95 07900
8.00	8	91	53	43	36	127.95 08000
8.10	10	103	61	49	40	185.09 08100
8.20	10	103	61	49	40	185.09 08200
8.30	10	103	61	49	40	185.09 08300
8.40	10	103	61	49	40	185.09 08400
8.50	10	103	61	49	40	185.09 08500
8.60	10	103	61	49	40	185.09 08600
8.70	10	103	61	49	40	185.09 08700
8.80	10	103	61	49	40	185.09 08800
8.90	10	103	61	49	40	185.09 08900
9.00	10	103	61	49	40	185.09 09000

10 789 ...

DC _{m7} mm	DCONMS _{h6} mm	OAL mm	LCF mm	LU mm	LS mm	£ T4
9.10	10	103	61	49	40	185.09 09100
9.20	10	103	61	49	40	185.09 09200
9.30	10	103	61	49	40	185.09 09300
9.40	10	103	61	49	40	185.09 09400
9.50	10	103	61	49	40	185.09 09500
9.60	10	103	61	49	40	185.09 09600
9.70	10	103	61	49	40	185.09 09700
9.80	10	103	61	49	40	185.09 09800
9.90	10	103	61	49	40	185.09 09900
10.00	10	103	61	49	40	185.09 10000
10.10	12	118	71	56	45	259.13 10100
10.20	12	118	71	56	45	259.13 10200
10.30	12	118	71	56	45	259.13 10300
10.40	12	118	71	56	45	259.13 10400
10.50	12	118	71	56	45	259.13 10500
10.60	12	118	71	56	45	259.13 10600
10.70	12	118	71	56	45	259.13 10700
10.80	12	118	71	56	45	259.13 10800
10.90	12	118	71	56	45	259.13 10900
11.00	12	118	71	56	45	259.13 11000
11.10	12	118	71	56	45	259.13 11100
11.20	12	118	71	56	45	259.13 11200
11.30	12	118	71	56	45	259.13 11300
11.40	12	118	71	56	45	259.13 11400
11.50	12	118	71	56	45	259.13 11500
11.60	12	118	71	56	45	259.13 11600
11.70	12	118	71	56	45	259.13 11700
11.80	12	118	71	56	45	259.13 11800
11.90	12	118	71	56	45	259.13 11900
12.00	12	118	71	56	45	259.13 12000
12.20	14	124	77	60	45	352.45 12200
12.50	14	124	77	60	45	352.45 12500
12.80	14	124	77	60	45	352.45 12800
13.00	14	124	77	60	45	352.45 13000
13.50	14	124	77	60	45	352.45 13500
13.80	14	124	77	60	45	352.45 13800
14.00	14	124	77	60	45	352.45 14000
14.50	16	133	83	63	48	439.80 14500
14.80	16	133	83	63	48	439.80 14800
15.00	16	133	83	63	48	439.80 15000
15.50	16	133	83	63	48	439.80 15500
15.80	16	133	83	63	48	439.80 15800
16.00	16	133	83	63	48	439.80 16000
16.50	18	143	93	71	48	579.01 16500
16.80	18	143	93	71	48	579.01 16800
17.00	18	143	93	71	48	579.01 17000
17.50	18	143	93	71	48	579.01 17500
17.80	18	143	93	71	48	579.01 17800
18.00	18	143	93	71	48	579.01 18000
18.50	20	153	101	77	50	749.30 18500
18.80	20	153	101	77	50	749.30 18800
19.00	20	153	101	77	50	749.30 19000
19.50	20	153	101	77	50	749.30 19500
19.80	20	153	101	77	50	749.30 19800
20.00	20	153	101	77	50	749.30 20000

P	●
M	●
K	●
N	○
S	
H	
O	

→ v. Page 112

WTX – High-feed drills, DIN 6537

- ▲ Four fluted high-feed drill
- ▲ Specialises in steel processing
- ▲ Has four spiral coolant holes

- ▲ Innovative cutting edge geometry guarantees high positioning accuracy

- ▲ Outstanding drilling quality in terms of tolerance, surface finish and position

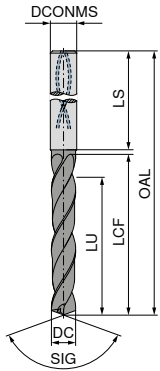
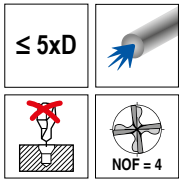

HFDS
DPX14S
DRAGONSKIN



SIG 130°
Solid carbide

10 798 ...

DC _{m7} mm	DCONMS _{h6} mm	OAL mm	LCF mm	LU mm	LS mm	£ T4	
6.0	8	89	51	40	36	121.94	06000
6.1	10	102	59	47	40	162.59	06100
6.2	10	102	59	47	40	162.59	06200
6.3	10	102	59	47	40	162.59	06300
6.4	10	102	59	47	40	162.59	06400
6.5	10	102	59	47	40	162.59	06500
6.6	10	102	59	47	40	162.59	06600
6.7	10	102	59	47	40	162.59	06700
6.8	10	102	59	47	40	162.59	06800
6.9	10	102	59	47	40	162.59	06900
7.0	10	102	59	47	40	162.59	07000
7.1	10	102	59	47	40	162.59	07100
7.2	10	102	59	47	40	162.59	07200
7.3	10	102	59	47	40	162.59	07300
7.4	10	102	59	47	40	162.59	07400
7.5	10	102	59	47	40	162.59	07500
7.6	10	102	59	47	40	162.59	07600
7.7	10	102	59	47	40	162.59	07700
7.8	10	102	59	47	40	162.59	07800
7.9	10	102	59	47	40	162.59	07900
8.0	10	102	59	47	40	162.59	08000
8.1	12	118	70	55	45	228.94	08100
8.2	12	118	70	55	45	228.94	08200
8.3	12	118	70	55	45	228.94	08300
8.4	12	118	70	55	45	228.94	08400
8.5	12	118	70	55	45	228.94	08500
8.6	12	118	70	55	45	228.94	08600
8.7	12	118	70	55	45	228.94	08700
8.8	12	118	70	55	45	228.94	08800
8.9	12	118	70	55	45	228.94	08900
9.0	12	118	70	55	45	228.94	09000
9.1	12	118	70	55	45	228.94	09100
9.2	12	118	70	55	45	228.94	09200
9.3	12	118	70	55	45	228.94	09300
9.4	12	118	70	55	45	228.94	09400
9.5	12	118	70	55	45	228.94	09500
9.6	12	118	70	55	45	228.94	09600
9.7	12	118	70	55	45	228.94	09700
9.8	12	118	70	55	45	228.94	09800
9.9	12	118	70	55	45	228.94	09900
10.0	12	118	70	55	45	228.94	10000
10.2	14	124	76	60	45	303.96	10200
10.5	14	124	76	60	45	303.96	10500
11.0	14	124	76	60	45	303.96	11000
11.5	14	124	76	60	45	303.96	11500
12.0	14	124	76	60	45	303.96	12000
12.5	16	142	91	73	48	412.77	12500
13.0	16	142	91	73	48	412.77	13000

10 798 ...

DC _{m7} mm	DCONMS _{h6} mm	OAL mm	LCF mm	LU mm	LS mm	£ T4	
14.0	16	142	91	73	48	412.77	14000
14.3	16	142	91	73	48	514.04	14300
14.5	16	142	91	73	48	514.04	14500
15.0	18	142	91	73	48	514.04	15000
16.0	18	142	91	73	48	514.04	16000

P	●
M	○
K	●
N	○
S	○
H	○
O	○

→ v_c Page 125

WTX – High Performance Drill, factory standard

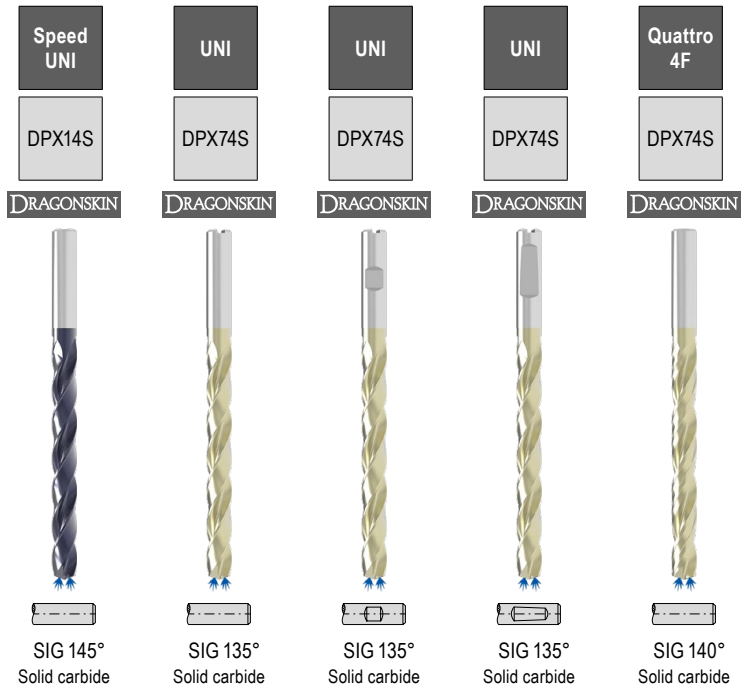
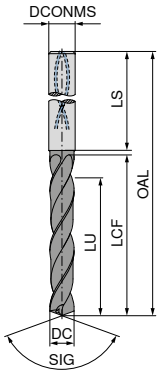
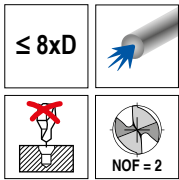

DC _{m7n7} mm	DCONMS _{h6} mm	OAL mm	LCF mm	LU mm	LS mm	10 782 ...		11 789 ...		11 790 ...		11 788 ...		10 736 ...	
						£ T4		£ T7		£ T7		£ T7		£ T4	
3.00	6	72	34	29	36	214.92	03000	156.99	030	156.99	030	156.99	030	235.60	03000
3.10	6	72	34	29	36	214.92	03100	156.99	031	156.99	031	156.99	031	235.60	03100
3.20	6	72	34	29	36	214.92	03200	156.99	032	156.99	032	156.99	032	235.60	03200
3.30	6	72	34	29	36	214.92	03300	156.99	033	156.99	033	156.99	033	235.60	03300
3.40	6	72	34	29	36	214.92	03400	156.99	034	156.99	034	156.99	034	235.60	03400
3.50	6	72	34	29	36	214.92	03500	156.99	035	156.99	035	156.99	035	235.60	03500
3.60	6	72	34	29	36	214.92	03600	156.99	036	156.99	036	156.99	036	235.60	03600
3.70	6	72	34	29	36	214.92	03700	156.99	037	156.99	037	156.99	037	235.60	03700
3.80	6	81	43	36	36	214.92	03800	156.99	038	156.99	038	156.99	038	235.60	03800
3.90	6	81	43	36	36	214.92	03900	156.99	039	156.99	039	156.99	039	235.60	03900
4.00	6	81	43	36	36	214.92	04000	156.99	040	156.99	040	156.99	040	235.60	04000
4.10	6	81	43	36	36	214.92	04100	156.99	041	156.99	041	156.99	041	235.60	04100
4.20	6	81	43	36	36	214.92	04200	156.99	042	156.99	042	156.99	042	235.60	04200
4.30	6	81	43	36	36	214.92	04300	156.99	043	156.99	043	156.99	043	235.60	04300
4.40	6	81	43	36	36	214.92	04400	156.99	044	156.99	044	156.99	044	235.60	04400
4.50	6	81	43	36	36	214.92	04500	156.99	045	156.99	045	156.99	045	235.60	04500
4.60	6	81	43	36	36	214.92	04600	156.99	046	156.99	046	156.99	046	235.60	04600
4.65	6	81	43	36	36	214.92	04650								
4.70	6	81	43	36	36	214.92	04700	156.99	047	156.99	047	156.99	047	235.60	04700
4.80	6	95	57	48	36	214.92	04800	156.99	048	156.99	048	156.99	048	235.60	04800
4.90	6	95	57	48	36	214.92	04900	156.99	049	156.99	049	156.99	049	235.60	04900
5.00	6	95	57	48	36	214.92	05000	156.99	050	156.99	050	156.99	050	235.60	05000
5.10	6	95	57	48	36	214.92	05100	156.99	051	156.99	051	156.99	051	235.60	05100
5.20	6	95	57	48	36	214.92	05200	156.99	052	156.99	052	156.99	052	235.60	05200
5.30	6	95	57	48	36	214.92	05300	156.99	053	156.99	053	156.99	053	235.60	05300
5.40	6	95	57	48	36	214.92	05400	156.99	054	156.99	054	156.99	054	235.60	05400
5.50	6	95	57	48	36	214.92	05500	156.99	055	156.99	055	156.99	055	235.60	05500
5.55	6	95	57	48	36	214.92	05550								
5.60	6	95	57	48	36	214.92	05600	156.99	056	156.99	056	156.99	056	235.60	05600
5.70	6	95	57	48	36	214.92	05700	156.99	057	156.99	057	156.99	057	235.60	05700
5.80	6	95	57	48	36	214.92	05800	156.99	058	156.99	058	156.99	058	235.60	05800
5.90	6	95	57	48	36	214.92	05900	156.99	059	156.99	059	156.99	059	235.60	05900
6.00	6	95	57	48	36	214.92	06000	156.99	060	156.99	060	156.99	060	235.60	06000
6.10	8	114	76	64	36	288.42	06100	190.38	061	190.38	061	190.38	061	259.19	06100

P	•	•	•	•	•
M	•	•	•	•	•
K	•	•	•	•	•
N					
S					
H		○	○	○	○
O					

→ v_c Page 111–120

Ø DC_{m7} for Type UNI and Quattro 4F/ Ø DC_{n7} for Type Speed UNI

WTX – High Performance Drill, factory standard

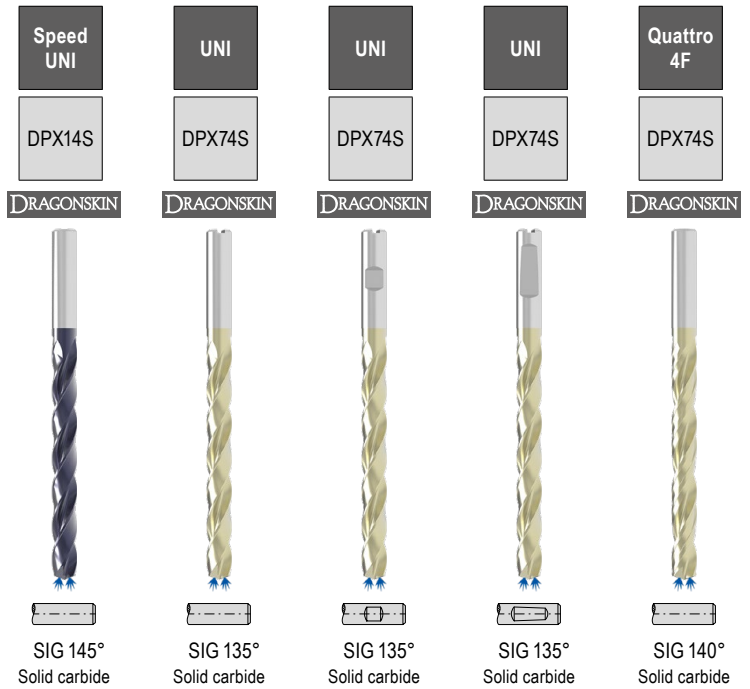
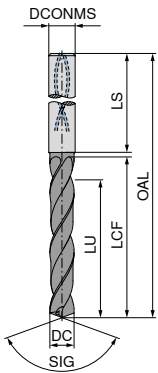
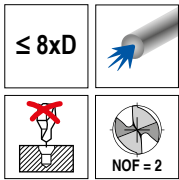

DC _{m7h7} mm	DCONMS _{h6} mm	OAL mm	LCF mm	LU mm	LS mm	10 782 ...		11 789 ...		11 790 ...		11 788 ...		10 736 ...	
						£	T4	£	T7	£	T7	£	T7	£	T4
6.20	8	114	76	64	36	288.42	06200	190.38	062	190.38	062	190.38	062	259.19	06200
6.30	8	114	76	64	36	288.42	06300	190.38	063	190.38	063	190.38	063	259.19	06300
6.40	8	114	76	64	36	288.42	06400	190.38	064	190.38	064	190.38	064	259.19	06400
6.50	8	114	76	64	36	288.42	06500	190.38	065	190.38	065	190.38	065	259.19	06500
6.60	8	114	76	64	36	288.42	06600	190.38	066	190.38	066	190.38	066	259.19	06600
6.70	8	114	76	64	36	288.42	06700	190.38	067	190.38	067	190.38	067	259.19	06700
6.80	8	114	76	64	36	288.42	06800	190.38	068	190.38	068	190.38	068	259.19	06800
6.90	8	114	76	64	36	288.42	06900	190.38	069	190.38	069	190.38	069	259.19	06900
7.00	8	114	76	64	36	288.42	07000	190.38	070	190.38	070	190.38	070	259.19	07000
7.10	8	114	76	64	36	288.42	07100	190.38	071	190.38	071	190.38	071	259.19	07100
7.20	8	114	76	64	36	288.42	07200	190.38	072	190.38	072	190.38	072	259.19	07200
7.30	8	114	76	64	36	288.42	07300	190.38	073	190.38	073	190.38	073	259.19	07300
7.40	8	114	76	64	36	288.42	07400	190.38	074	190.38	074	190.38	074	259.19	07400
7.50	8	114	76	64	36	288.42	07500	190.38	075	190.38	075	190.38	075	259.19	07500
7.60	8	114	76	64	36	288.42	07600	190.38	076	190.38	076	190.38	076	259.19	07600
7.70	8	114	76	64	36	288.42	07700	190.38	077	190.38	077	190.38	077	259.19	07700
7.80	8	114	76	64	36	288.42	07800	190.38	078	190.38	078	190.38	078	259.19	07800
7.90	8	114	76	64	36	288.42	07900	190.38	079	190.38	079	190.38	079	259.19	07900
8.00	8	114	76	64	36	288.42	08000	190.38	080	190.38	080	190.38	080	259.19	08000
8.10	10	142	95	80	40	416.61	08100	230.58	081	230.58	081	230.58	081	373.37	08100
8.20	10	142	95	80	40	416.61	08200	230.58	082	230.58	082	230.58	082	373.37	08200
8.30	10	142	95	80	40	416.61	08300	230.58	083	230.58	083	230.58	083	373.37	08300
8.40	10	142	95	80	40	416.61	08400	230.58	084	230.58	084	230.58	084	373.37	08400
8.50	10	142	95	80	40	416.61	08500	230.58	085	230.58	085	230.58	085	373.37	08500
8.60	10	142	95	80	40	416.61	08600	230.58	086	230.58	086	230.58	086	373.37	08600
8.70	10	142	95	80	40	416.61	08700	230.58	087	230.58	087	230.58	087	373.37	08700
8.80	10	142	95	80	40	416.61	08800	230.58	088	230.58	088	230.58	088	373.37	08800
8.90	10	142	95	80	40	416.61	08900	230.58	089	230.58	089	230.58	089	373.37	08900
9.00	10	142	95	80	40	416.61	09000	230.58	090	230.58	090	230.58	090	373.37	09000
9.10	10	142	95	80	40	416.61	09100	230.58	091	230.58	091	230.58	091	373.37	09100
9.20	10	142	95	80	40	416.61	09200	230.58	092	230.58	092	230.58	092	373.37	09200
9.30	10	142	95	80	40	416.61	09300	230.58	093	230.58	093	230.58	093	373.37	09300
9.40	10	142	95	80	40	416.61	09400	230.58	094	230.58	094	230.58	094	373.37	09400
9.50	10	142	95	80	40	416.61	09500	230.58	095	230.58	095	230.58	095	373.37	09500

P	•	•	•	•	•
M	•	•	•	•	•
K	•	•	•	•	•
N					
S					
H		○	○	○	○
O					

→ v_c Page 111–120

Ø DC_{m7} for Type UNI and Quattro 4F/ Ø DC_{h7} for Type Speed UNI

WTX – High Performance Drill, factory standard

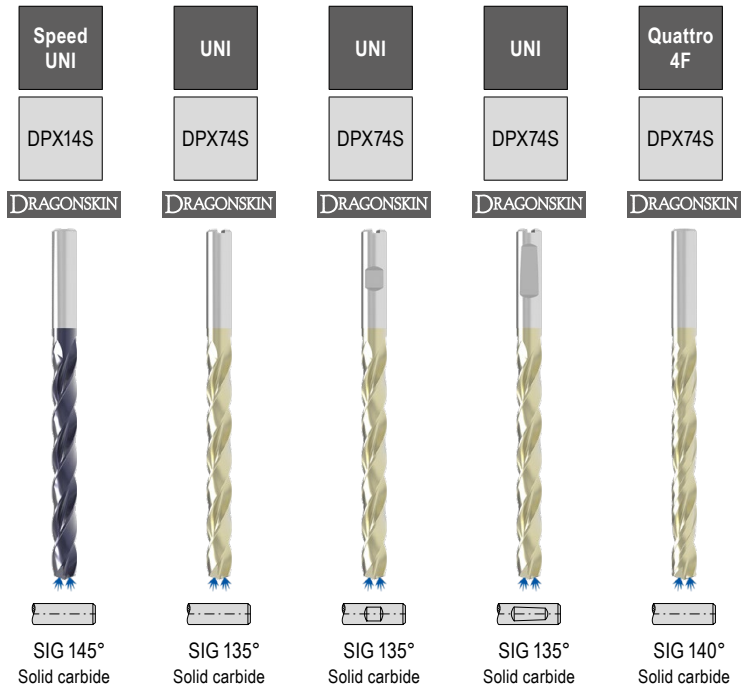
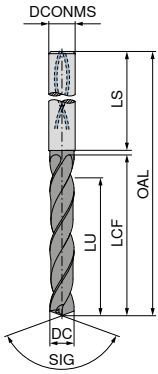
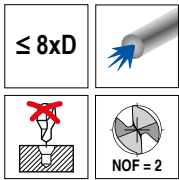

DC _{m7n7} mm	DCONMS _{h6} mm	OAL mm	LCF mm	LU mm	LS mm	10 782 ...		11 789 ...		11 790 ...		11 788 ...		10 736 ...	
						£	T4	£	T7	£	T7	£	T7	£	T4
9.60	10	142	95	80	40	416.61	09600	230.58	096	230.58	096	230.58	096	373.37	09600
9.70	10	142	95	80	40	416.61	09700	230.58	097	230.58	097	230.58	097	373.37	09700
9.80	10	142	95	80	40	416.61	09800	230.58	098	230.58	098	230.58	098	373.37	09800
9.90	10	142	95	80	40	416.61	09900	230.58	099	230.58	099	230.58	099	373.37	09900
10.00	10	142	95	80	40	416.61	10000	230.58	100	230.58	100	230.58	100	373.37	10000
10.10	12	162	114	96	45	537.30	10100	304.37	101	304.37	101	304.37	101	479.98	10100
10.20	12	162	114	96	45	537.30	10200	304.37	102	304.37	102	304.37	102	479.98	10200
10.30	12	162	114	96	45	537.30	10300	304.37	103	304.37	103	304.37	103	479.98	10300
10.40	12	162	114	96	45	537.30	10400	304.37	104	304.37	104	304.37	104	479.98	10400
10.50	12	162	114	96	45	537.30	10500	304.37	105	304.37	105	304.37	105	479.98	10500
10.60	12	162	114	96	45	537.30	10600	304.37	106	304.37	106	304.37	106	479.98	10600
10.70	12	162	114	96	45	537.30	10700	304.37	107	304.37	107	304.37	107	479.98	10700
10.80	12	162	114	96	45	537.30	10800	304.37	108	304.37	108	304.37	108	479.98	10800
10.90	12	162	114	96	45	537.30	10900	304.37	109	304.37	109	304.37	109	479.98	10900
11.00	12	162	114	96	45	537.30	11000	304.37	110	304.37	110	304.37	110	479.98	11000
11.10	12	162	114	96	45	537.30	11100	304.37	111	304.37	111	304.37	111	479.98	11100
11.20	12	162	114	96	45	537.30	11200	304.37	112	304.37	112	304.37	112	479.98	11200
11.30	12	162	114	96	45	537.30	11300	304.37	113	304.37	113	304.37	113	479.98	11300
11.40	12	162	114	96	45	537.30	11400	304.37	114	304.37	114	304.37	114	479.98	11400
11.50	12	162	114	96	45	537.30	11500	304.37	115	304.37	115	304.37	115	479.98	11500
11.60	12	162	114	96	45	537.30	11600	304.37	116	304.37	116	304.37	116	479.98	11600
11.70	12	162	114	96	45	537.30	11700	304.37	117	304.37	117	304.37	117	479.98	11700
11.80	12	162	114	96	45	537.30	11800	304.37	118	304.37	118	304.37	118	479.98	11800
11.90	12	162	114	96	45	537.30	11900	304.37	119	304.37	119	304.37	119	479.98	11900
12.00	12	162	114	96	45	537.30	12000	304.37	120	304.37	120	304.37	120	479.98	12000
12.50	14	178	131	112	45	644.77	12500	373.37	125	373.37	125	373.37	125	658.62	12500
12.80	14	178	131	112	45	644.77	12800	373.37	128	373.37	128	373.37	128	658.62	12800
13.00	14	178	131	112	45	644.77	13000	373.37	130	373.37	130	373.37	130	658.62	13000
13.50	14	178	131	112	45	644.77	13500	373.37	135	373.37	135	373.37	135	658.62	13500
13.80	14	178	131	112	45	644.77	13800	373.37	138	373.37	138	373.37	138	658.62	13800
14.00	14	178	131	112	45	644.77	14000	373.37	140	373.37	140	373.37	140	658.62	14000
14.50	16	203	152	128	48	869.09	14500	463.38	145	463.38	145	463.38	145	830.64	14500
14.80	16	203	152	128	48	869.09	14800	463.38	148	463.38	148	463.38	148	830.64	14800
15.00	16	203	152	128	48	869.09	15000	463.38	150	463.38	150	463.38	150	830.64	15000

P	●	●	●	●	●
M	●				
K	●	●	●	●	●
N					
S					
H		○	○	○	○
O					

→ v_c Page 111–120

Ø DC_{m7} for Type UNI and Quattro 4F/ Ø DC_{n7} for Type Speed UNI

WTX – High Performance Drill, factory standard

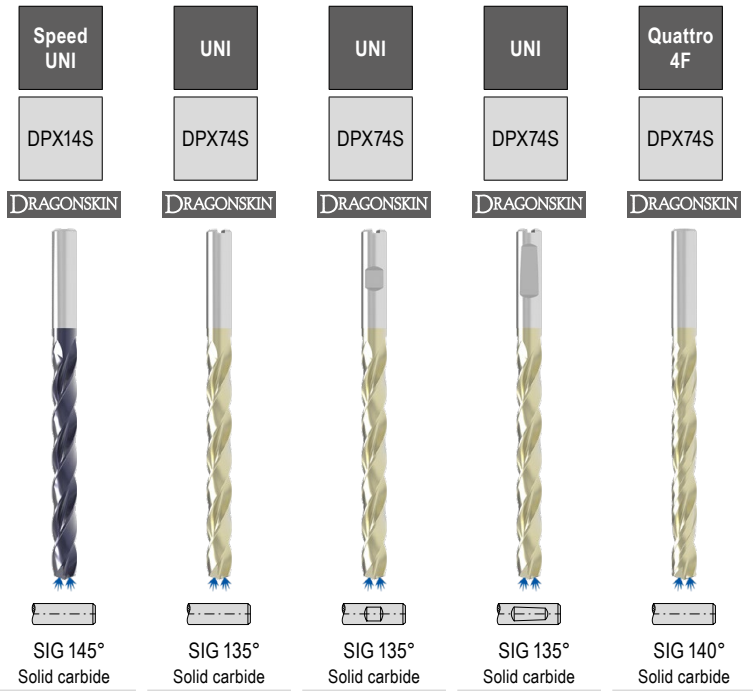
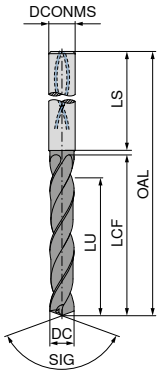
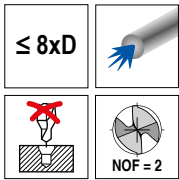

DC _{mTn7} mm	DCONMS _{h6} mm	OAL mm	LCF mm	LU mm	LS mm	10 782 ...		11 789 ...		11 790 ...		11 788 ...		10 736 ...	
						£	T4	£	T7	£	T7	£	T7	£	T4
15.50	16	203	152	128	48	869.09	15500	463.38	155	463.38	155	463.38	155	830.64	15500
15.80	16	203	152	128	48	869.09	15800	463.38	158	463.38	158	463.38	158	830.64	15800
16.00	16	203	152	128	48	869.09	16000	463.38	160	463.38	160	463.38	160	830.64	16000
16.50	18	222	171	144	48	1,219.75	16500	587.00	165	587.00	165	587.00	165	1,192.50	16500
16.80	18	222	171	144	48	1,219.75	16800	587.00	168	587.00	168	587.00	168	1,192.50	16800
17.00	18	222	171	144	48	1,219.75	17000	587.00	170	587.00	170	587.00	170	1,192.50	17000
17.50	18	222	171	144	48	1,219.75	17500	587.00	175	587.00	175	587.00	175	1,192.50	17500
17.80	18	222	171	144	48	1,219.75	17800	587.00	178	587.00	178	587.00	178	1,192.50	17800
18.00	18	222	171	144	48	1,219.75	18000	587.00	180	587.00	180	587.00	180	1,192.50	18000
18.50	20	243	190	160	50			689.00	185	689.00	185	689.00	185		
18.80	20	243	190	160	50			689.00	188	689.00	188	689.00	188		
19.00	20	243	190	160	50			689.00	190	689.00	190	689.00	190		
19.50	20	243	190	160	50			689.00	195	689.00	195	689.00	195		
19.80	20	243	190	160	50			689.00	198	689.00	198	689.00	198		
20.00	20	243	190	160	50			689.00	200	689.00	200	689.00	200		
P															
M															
K															
N															
S															
H															
O															

→ v_c Page 111-120

Ø DC_{m7} for Type UNI and Quattro 4F/ Ø DC_{n7} for Type Speed UNI

High Performance Drill, factory standard

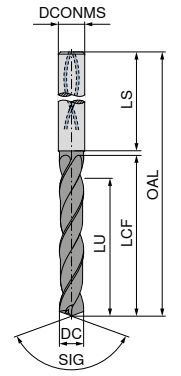
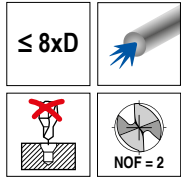

NEW
UNI
TiAlN



SIG 135°
Solid carbide

11 704 ...

DC _{h7} mm	DCONMS _{h6} mm	OAL mm	LCF mm	LU mm	LS mm	£ T1/9C	
3.0	6	72	34	29.5	36	71.36	03000
3.1	6	72	34	29.3	36	71.36	03100
3.2	6	72	34	29.2	36	71.36	03200
3.3	6	72	34	29.0	36	71.36	03300
3.4	6	72	34	28.9	36	71.36	03400
3.5	6	72	34	28.7	36	71.36	03500
3.6	6	72	34	28.6	36	71.36	03600
3.7	6	72	34	28.4	36	71.36	03700
3.8	6	81	43	37.3	36	71.36	03800
3.9	6	81	43	37.1	36	71.36	03900
4.0	6	81	43	37.0	36	71.36	04000
4.1	6	81	43	36.8	36	71.36	04100
4.2	6	81	43	36.7	36	71.36	04200
4.3	6	81	43	36.5	36	71.36	04300
4.4	6	81	43	36.4	36	71.36	04400
4.5	6	81	43	36.2	36	71.36	04500
4.6	6	81	43	36.1	36	71.36	04600
4.7	6	81	43	35.9	36	71.36	04700
4.8	6	95	57	49.8	36	71.36	04800
4.9	6	95	57	49.6	36	71.36	04900
5.0	6	95	57	49.5	36	71.36	05000
5.1	6	95	57	49.3	36	71.36	05100
5.2	6	95	57	49.2	36	71.36	05200
5.3	6	95	57	49.0	36	71.36	05300
5.4	6	95	57	48.9	36	71.36	05400
5.5	6	95	57	48.7	36	71.36	05500
5.6	6	95	57	48.6	36	71.36	05600
5.7	6	95	57	48.4	36	71.36	05700
5.8	6	95	57	48.3	36	71.36	05800
5.9	6	95	57	48.1	36	71.36	05900
6.0	6	95	57	48.0	36	71.36	06000
6.1	8	114	76	66.8	36	88.29	06100
6.2	8	114	76	66.7	36	88.29	06200
6.3	8	114	76	66.5	36	88.29	06300
6.4	8	114	76	66.4	36	88.29	06400
6.5	8	114	76	66.2	36	88.29	06500
6.6	8	114	76	66.1	36	88.29	06600
6.7	8	114	76	65.9	36	88.29	06700
6.8	8	114	76	65.8	36	88.29	06800
6.9	8	114	76	65.6	36	88.29	06900
7.0	8	114	76	65.5	36	88.29	07000
7.1	8	114	76	65.3	36	88.29	07100
7.2	8	114	76	65.2	36	88.29	07200
7.3	8	114	76	65.0	36	88.29	07300
7.4	8	114	76	64.9	36	88.29	07400
7.5	8	114	76	64.7	36	88.29	07500
7.6	8	114	76	64.6	36	88.29	07600
7.7	8	114	76	64.4	36	88.29	07700
7.8	8	114	76	64.3	36	88.29	07800
7.9	8	114	76	64.1	36	88.29	07900
8.0	8	114	76	64.0	36	88.29	08000

11 704 ...

DC _{h7} mm	DCONMS _{h6} mm	OAL mm	LCF mm	LU mm	LS mm	£ T1/9C	
8.1	10	142	95	82.8	40	107.64	08100
8.2	10	142	95	82.7	40	107.64	08200
8.3	10	142	95	82.5	40	107.64	08300
8.4	10	142	95	82.4	40	107.64	08400
8.5	10	142	95	82.2	40	107.64	08500
8.6	10	142	95	82.1	40	107.64	08600
8.7	10	142	95	81.9	40	107.64	08700
8.8	10	142	95	81.8	40	107.64	08800
8.9	10	142	95	81.6	40	107.64	08900
9.0	10	142	95	81.5	40	107.64	09000
9.1	10	142	95	81.3	40	107.64	09100
9.2	10	142	95	81.2	40	107.64	09200
9.3	10	142	95	81.0	40	107.64	09300
9.4	10	142	95	80.9	40	107.64	09400
9.5	10	142	95	80.7	40	107.64	09500
9.6	10	142	95	80.6	40	107.64	09600
9.7	10	142	95	80.4	40	107.64	09700
9.8	10	142	95	80.3	40	107.64	09800
9.9	10	142	95	80.1	40	107.64	09900
10.0	10	142	95	80.0	40	107.64	10000
10.2	12	162	114	98.7	45	143.91	10200
10.5	12	162	114	98.2	45	143.91	10500
10.8	12	162	114	97.8	45	143.91	10800
11.0	12	162	114	97.5	45	143.91	11000
11.5	12	162	114	96.7	45	143.91	11500
11.8	12	162	114	96.3	45	143.91	11800
12.0	12	162	114	96.0	45	143.91	12000
12.2	14	178	131	112.7	45	215.27	12200
12.5	14	178	131	112.2	45	215.27	12500
12.7	14	178	131	111.9	45	249.60	12700
13.0	14	178	131	111.5	45	215.27	13000
13.5	14	178	131	110.7	45	215.27	13500
14.0	14	178	131	110.0	45	215.27	14000
14.5	16	203	152	130.2	48	281.79	14500
15.0	16	203	152	129.5	48	281.79	15000
15.5	16	203	152	128.7	48	281.79	15500
16.0	16	203	152	128.0	48	281.79	16000
16.5	18	222	171	146.2	48	364.03	16500
17.0	18	222	171	145.5	48	364.03	17000
17.5	18	222	171	144.7	48	364.03	17500
18.0	18	222	171	144.0	48	364.03	18000
18.5	20	243	190	162.2	50	405.15	18500
19.0	20	243	190	161.5	50	405.15	19000
19.5	20	243	190	160.7	50	405.15	19500
20.0	20	243	190	160.0	50	405.15	20000

P	●
M	●
K	●
N	●
S	●
H	●
O	●

→ v_c Page 130

WTX – High Performance Drill, factory standard

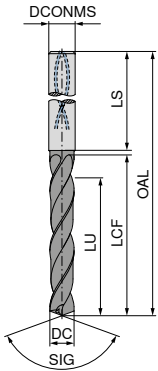
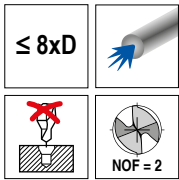

DC _{h7/m7}	DCONMS _{h6}	OAL	LCF	LU	LS
mm	mm	mm	mm	mm	mm
3.0	6	72	34	29	36
3.1	6	72	34	29	36
3.2	6	72	34	29	36
3.3	6	72	34	29	36
3.4	6	72	34	29	36
3.5	6	72	34	29	36
3.6	6	72	34	29	36
3.7	6	72	34	29	36
3.8	6	81	43	36	36
3.9	6	81	43	36	36
4.0	6	81	43	36	36
4.1	6	81	43	36	36
4.2	6	81	43	36	36
4.3	6	81	43	36	36
4.4	6	81	43	36	36
4.5	6	81	43	36	36
4.6	6	81	43	36	36
4.7	6	81	43	36	36
4.8	6	95	57	48	36
4.9	6	95	57	48	36
5.0	6	95	57	48	36
5.1	6	95	57	48	36
5.2	6	95	57	48	36
5.3	6	95	57	48	36
5.4	6	95	57	48	36
5.5	6	95	57	48	36
5.6	6	95	57	48	36
5.7	6	95	57	48	36
5.8	6	95	57	48	36
5.9	6	95	57	48	36
6.0	6	95	57	48	36
6.1	8	114	76	64	36
6.2	8	114	76	64	36
6.3	8	114	76	64	36
6.4	8	114	76	64	36
6.5	8	114	76	64	36
6.6	8	114	76	64	36
6.7	8	114	76	64	36
6.8	8	114	76	64	36
6.9	8	114	76	64	36
7.0	8	114	76	64	36
7.1	8	114	76	64	36
7.2	8	114	76	64	36
7.3	8	114	76	64	36
7.4	8	114	76	64	36

10 770 ...		10 792 ...	
£	T4	£	T4
177.62	030	174.89	03000
177.62	031	174.89	03100
177.62	032	174.89	03200
177.62	033	174.89	03300
177.62	034	174.89	03400
177.62	035	174.89	03500
177.62	036	174.89	03600
177.62	037	174.89	03700
177.62	038	174.89	03800
177.62	039	174.89	03900
177.62	040	174.89	04000
177.62	041	174.89	04100
177.62	042	174.89	04200
177.62	043	174.89	04300
177.62	044	174.89	04400
177.62	045	174.89	04500
177.62	046	174.89	04600
177.62	047	174.89	04700
177.62	048	174.89	04800
177.62	049	174.89	04900
177.62	050	174.89	05000
177.62	051	174.89	05100
177.62	052	174.89	05200
177.62	053	174.89	05300
177.62	054	174.89	05400
177.62	055	174.89	05500
177.62	056	174.89	05600
177.62	057	174.89	05700
177.62	058	174.89	05800
177.62	059	174.89	05900
177.62	060	174.89	06000
213.89	061	219.71	06100
213.89	062	219.71	06200
213.89	063	219.71	06300
213.89	064	219.71	06400
213.89	065	219.71	06500
213.89	066	219.71	06600
213.89	067	219.71	06700
213.89	068	219.71	06800
213.89	069	219.71	06900
213.89	070	219.71	07000
213.89	071	219.71	07100
213.89	072	219.71	07200
213.89	073	219.71	07300
213.89	074	219.71	07400

P	○
M	●
K	○
N	○ ●
S	●
H	
O	

→ v_c Page 117+123

Ø DC_{m7} for Type VA / Ø DC_{h7} for Type AL

WTX – High Performance Drill, factory standard

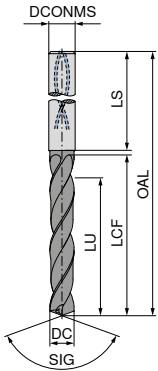
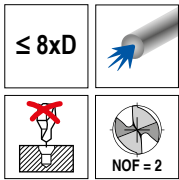

DC _{h7/m7}	DCONMS _{h6}	OAL	LCF	LU	LS
mm	mm	mm	mm	mm	mm
7.5	8	114	76	64	36
7.6	8	114	76	64	36
7.7	8	114	76	64	36
7.8	8	114	76	64	36
7.9	8	114	76	64	36
8.0	8	114	76	64	36
8.1	10	142	95	80	40
8.2	10	142	95	80	40
8.3	10	142	95	80	40
8.4	10	142	95	80	40
8.5	10	142	95	80	40
8.6	10	142	95	80	40
8.7	10	142	95	80	40
8.8	10	142	95	80	40
8.9	10	142	95	80	40
9.0	10	142	95	80	40
9.1	10	142	95	80	40
9.2	10	142	95	80	40
9.3	10	142	95	80	40
9.4	10	142	95	80	40
9.5	10	142	95	80	40
9.6	10	142	95	80	40
9.7	10	142	95	80	40
9.8	10	142	95	80	40
9.9	10	142	95	80	40
10.0	10	142	95	80	40
10.1	12	162	114	96	45
10.2	12	162	114	96	45
10.3	12	162	114	96	45
10.4	12	162	114	96	45
10.5	12	162	114	96	45
10.6	12	162	114	96	45
10.7	12	162	114	96	45
10.8	12	162	114	96	45
10.9	12	162	114	96	45
11.0	12	162	114	96	45
11.1	12	162	114	96	45
11.2	12	162	114	96	45
11.3	12	162	114	96	45
11.4	12	162	114	96	45
11.5	12	162	114	96	45
11.6	12	162	114	96	45
11.7	12	162	114	96	45
11.8	12	162	114	96	45
11.9	12	162	114	96	45

10 770 ...		10 792 ...	
£	T4	£	T4
213.89	075	219.71	07500
213.89	076	219.71	07600
213.89	077	219.71	07700
213.89	078	219.71	07800
213.89	079	219.71	07900
213.89	080	219.71	08000
309.39	081	278.92	08100
309.39	082	278.92	08200
309.39	083	278.92	08300
309.39	084	278.92	08400
309.39	085	278.92	08500
309.39	086	278.92	08600
309.39	087	278.92	08700
309.39	088	278.92	08800
309.39	089	278.92	08900
309.39	090	278.92	09000
309.39	091	278.92	09100
309.39	092	278.92	09200
309.39	093	278.92	09300
309.39	094	278.92	09400
309.39	095	278.92	09500
309.39	096	278.92	09600
309.39	097	278.92	09700
309.39	098	278.92	09800
309.39	099	278.92	09900
309.39	100	278.92	10000
397.39	101		
397.39	102	356.04	10200
397.39	103	356.04	10300
397.39	104	356.04	10400
397.39	105	356.04	10500
397.39	106		
397.39	107	356.04	10700
397.39	108	356.04	10800
397.39	109		
397.39	110	356.04	11000
397.39	111		
397.39	112	356.04	11200
397.39	113		
397.39	114		
397.39	115	356.04	11500
397.39	116	356.04	11600
397.39	117		
397.39	118	356.04	11800
397.39	119		

P	○
M	●
K	○
N	○ ●
S	●
H	
O	

→ v_c Page 117+123

Ø DC_{m7} for Type VA / Ø DC_{h7} for Type AL

WTX – High Performance Drill, factory standard

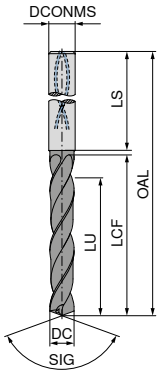
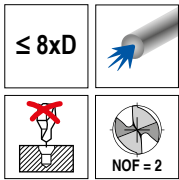

DC _{m7}	DCONMS _{h6}	OAL	LCF	LU	LS
mm	mm	mm	mm	mm	mm
12.0	12	162	114	96	45
12.2	14	178	131	112	45
12.5	14	178	133	112	45
12.5	14	178	131	112	45
12.8	14	178	133	112	45
12.8	14	178	131	112	45
13.0	14	178	133	112	45
13.0	14	178	131	112	45
13.2	14	178	131	112	45
13.5	14	178	131	112	45
13.5	14	178	133	112	45
13.8	14	178	131	112	45
13.8	14	178	133	112	45
14.0	14	178	133	112	45
14.0	14	178	131	112	45
14.2	16	203	152	128	48
14.5	16	203	152	128	48
14.8	16	203	152	128	48
15.0	16	203	152	128	48
15.2	16	203	152	128	48
15.5	16	203	152	128	48
15.8	16	203	152	128	48
16.0	16	203	152	128	48
16.2	18	222	171	144	48
16.5	18	222	171	144	48
16.8	18	222	171	144	48
17.0	18	222	171	144	48
17.2	18	222	171	144	48
17.5	18	222	171	144	48
17.8	18	222	171	144	48
18.0	18	222	171	144	48
18.2	20	243	190	160	50
18.5	20	243	190	160	50
18.8	20	243	190	160	50
19.0	20	243	190	160	50
19.1	20	243	190	160	50
19.2	20	243	190	160	50
19.5	20	243	190	160	50
19.8	20	243	190	160	50
20.0	20	243	190	160	50

10 770 ...		10 792 ...	
£		£	
T4		T4	
397.39	120	356.04	12000
		451.21	12200
477.27	125	451.21	12500
477.27	128	451.21	12800
477.27	130	451.21	13000
		451.21	13200
		451.21	13500
477.27	135	451.21	13800
477.27	138		
477.27	140	451.21	14000
		643.99	14200
645.34	145	643.99	14500
645.34	148	643.99	14800
645.34	150	643.99	15000
		643.99	15200
645.34	155	643.99	15500
645.34	158	643.99	15800
645.34	160	643.99	16000
		788.59	16200
902.86	165	788.59	16500
902.86	168	788.59	16800
902.86	170	788.59	17000
		788.59	17200
902.86	175	788.59	17500
902.86	178	788.59	17800
902.86	180	788.59	18000
		961.80	18200
1,138.90	185	961.80	18500
1,138.90	188	961.80	18800
1,138.90	190	961.80	19000
		961.80	19100
		961.80	19200
1,138.90	195	961.80	19500
1,138.90	198	961.80	19800
1,138.90	200	961.80	20000

P	○
M	●
K	○
N	○ ●
S	●
H	
O	

→ v_c Page 117+123

Ø DC_{m7} for Type VA / Ø DC_{m7} for Type AL

WTX – High Feed Drill, factory standard

- ▲ Three fluted high-feed drill
- ▲ Universal application

- ▲ High positioning accuracy
- ▲ Suitable for difficult drilling applications

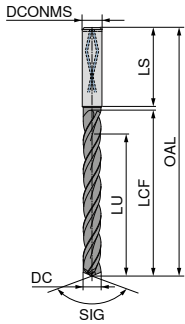
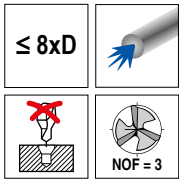

Feed UNI
DPX74S
DRAGONSKIN



SIG 135°
Solid carbide
10 794 ...

DC _{m7} mm	DCONMS _{h6} mm	OAL mm	LCF mm	LU mm	LS mm	£ T4	
4.00	6	81	43	36	36	180.66	04000
4.10	6	81	43	36	36	180.66	04100
4.20	6	81	43	36	36	180.66	04200
4.30	6	81	43	36	36	180.66	04300
4.40	6	81	43	36	36	180.66	04400
4.50	6	81	43	36	36	180.66	04500
4.60	6	81	43	36	36	180.66	04600
4.70	6	81	43	36	36	180.66	04700
4.80	6	95	57	48	36	180.66	04800
4.90	6	95	57	48	36	180.66	04900
5.00	6	95	57	48	36	180.66	05000
5.10	6	95	57	48	36	180.66	05100
5.20	6	95	57	48	36	180.66	05200
5.30	6	95	57	48	36	180.66	05300
5.40	6	95	57	48	36	180.66	05400
5.50	6	95	57	48	36	180.66	05500
5.55	6	95	57	48	36	180.66	05550
5.60	6	95	57	48	36	180.66	05600
5.70	6	95	57	48	36	180.66	05700
5.80	6	95	57	48	36	180.66	05800
5.90	6	95	57	48	36	180.66	05900
6.00	6	95	57	48	36	180.66	06000
6.10	8	114	76	64	36	241.37	06100
6.20	8	114	76	64	36	241.37	06200
6.30	8	114	76	64	36	241.37	06300
6.40	8	114	76	64	36	241.37	06400
6.50	8	114	76	64	36	241.37	06500
6.60	8	114	76	64	36	241.37	06600
6.70	8	114	76	64	36	241.37	06700
6.80	8	114	76	64	36	241.37	06800
6.90	8	114	76	64	36	241.37	06900
7.00	8	114	76	64	36	241.37	07000
7.10	8	114	76	64	36	241.37	07100
7.20	8	114	76	64	36	241.37	07200
7.30	8	114	76	64	36	241.37	07300
7.40	8	114	76	64	36	241.37	07400
7.50	8	114	76	64	36	241.37	07500
7.60	8	114	76	64	36	241.37	07600
7.70	8	114	76	64	36	241.37	07700
7.80	8	114	76	64	36	241.37	07800
7.90	8	114	76	64	36	241.37	07900
8.00	8	114	76	64	36	241.37	08000
8.10	10	142	95	80	40	347.99	08100
8.20	10	142	95	80	40	347.99	08200
8.30	10	142	95	80	40	347.99	08300
8.40	10	142	95	80	40	347.99	08400
8.50	10	142	95	80	40	347.99	08500
8.60	10	142	95	80	40	347.99	08600
8.70	10	142	95	80	40	347.99	08700
8.80	10	142	95	80	40	347.99	08800
8.90	10	142	95	80	40	347.99	08900
9.00	10	142	95	80	40	347.99	09000

10 794 ...

DC _{m7} mm	DCONMS _{h6} mm	OAL mm	LCF mm	LU mm	LS mm	£ T4	
9.10	10	142	95	80	40	347.99	09100
9.20	10	142	95	80	40	347.99	09200
9.30	10	142	95	80	40	347.99	09300
9.40	10	142	95	80	40	347.99	09400
9.50	10	142	95	80	40	347.99	09500
9.60	10	142	95	80	40	347.99	09600
9.70	10	142	95	80	40	347.99	09700
9.80	10	142	95	80	40	347.99	09800
9.90	10	142	95	80	40	347.99	09900
10.00	10	142	95	80	40	347.99	10000
10.10	12	162	114	96	45	450.19	10100
10.20	12	162	114	96	45	450.19	10200
10.30	12	162	114	96	45	450.19	10300
10.40	12	162	114	96	45	450.19	10400
10.50	12	162	114	96	45	450.19	10500
10.60	12	162	114	96	45	450.19	10600
10.70	12	162	114	96	45	450.19	10700
10.80	12	162	114	96	45	450.19	10800
10.90	12	162	114	96	45	450.19	10900
11.00	12	162	114	96	45	450.19	11000
11.10	12	162	114	96	45	450.19	11100
11.20	12	162	114	96	45	450.19	11200
11.30	12	162	114	96	45	450.19	11300
11.40	12	162	114	96	45	450.19	11400
11.50	12	162	114	96	45	450.19	11500
11.60	12	162	114	96	45	450.19	11600
11.70	12	162	114	96	45	450.19	11700
11.80	12	162	114	96	45	450.19	11800
11.90	12	162	114	96	45	450.19	11900
12.00	12	162	114	96	45	450.19	12000
12.20	14	178	131	112	45	540.50	12200
12.50	14	178	131	112	45	540.50	12500
12.80	14	178	131	112	45	540.50	12800
13.00	14	178	131	112	45	540.50	13000
13.50	14	178	131	112	45	540.50	13500
13.80	14	178	131	112	45	540.50	13800
14.00	14	178	131	112	45	540.50	14000
14.50	16	203	152	128	48	728.57	14500
14.80	16	203	152	128	48	728.57	14800
15.00	16	203	152	128	48	728.57	15000
15.50	16	203	152	128	48	728.57	15500
15.80	16	203	152	128	48	728.57	15800
16.00	16	203	152	128	48	728.57	16000
16.50	18	222	171	144	48	1,021.77	16500
16.80	18	222	171	144	48	1,021.77	16800
17.00	18	222	171	144	48	1,021.77	17000
17.50	18	222	171	144	48	1,021.77	17500
17.80	18	222	171	144	48	1,021.77	17800
18.00	18	222	171	144	48	1,021.77	18000
18.50	20	243	190	160	50	1,286.86	18500
18.80	20	243	190	160	50	1,286.86	18800
19.00	20	243	190	160	50	1,286.86	19000
19.50	20	243	190	160	50	1,286.86	19500
19.80	20	243	190	160	50	1,286.86	19800
20.00	20	243	190	160	50	1,286.86	20000

P	●
M	●
K	●
N	○
S	
H	
O	

→ v. Page 113

WTX – High Performance Drill, factory standard

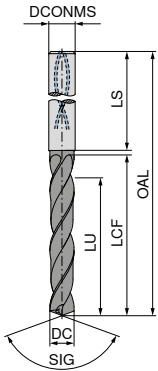
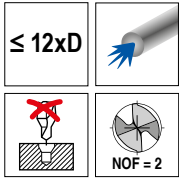

DC _{h7/m7}	DCONMS _{h6}	OAL	LCF	LU	LS
mm	mm	mm	mm	mm	mm
3.0	6	92	54	48	36
3.1	6	92	54	48	36
3.2	6	92	54	48	36
3.3	6	92	54	48	36
3.4	6	92	54	48	36
3.5	6	92	54	48	36
3.6	6	92	54	48	36
3.7	6	92	54	48	36
3.8	6	102	64	58	36
3.9	6	102	64	58	36
4.0	6	102	64	58	36
4.1	6	102	64	58	36
4.2	6	102	64	58	36
4.3	6	102	64	58	36
4.4	6	102	64	58	36
4.5	6	102	64	58	36
4.6	6	102	64	58	36
4.7	6	102	64	58	36
4.8	6	116	78	70	36
4.9	6	116	78	70	36
5.0	6	116	78	70	36
5.1	6	116	78	70	36
5.2	6	116	78	70	36
5.3	6	116	78	70	36
5.4	6	116	78	70	36
5.5	6	116	78	70	36
5.6	6	116	78	70	36
5.7	6	116	78	70	36
5.8	6	116	78	70	36
5.9	6	116	78	70	36
6.0	6	116	78	70	36
6.1	8	146	108	94	36
6.2	8	146	108	94	36
6.3	8	146	108	94	36
6.4	8	146	108	94	36
6.5	8	146	108	94	36
6.6	8	146	108	94	36
6.7	8	146	108	94	36
6.8	8	146	108	94	36
6.9	8	146	108	94	36
7.0	8	146	108	94	36
7.1	8	146	108	94	36
7.2	8	146	108	94	36

10 774 ...		10 737 ...		10 793 ...	
£	T4	£	T4	£	T4
214.75	03000	287.77	03000	211.43	03000
214.75	03100	287.77	03100	211.43	03100
214.75	03200	287.77	03200	211.43	03200
214.75	03300	287.77	03300	211.43	03300
214.75	03400	287.77	03400	211.43	03400
214.75	03500	287.77	03500	211.43	03500
214.75	03600	287.77	03600	211.43	03600
214.75	03700	287.77	03700	211.43	03700
214.75	03800	287.77	03800	211.43	03800
214.75	03900	287.77	03900	211.43	03900
214.75	04000	287.77	04000	211.43	04000
214.75	04100	287.77	04100	211.43	04100
214.75	04200	287.77	04200	211.43	04200
214.75	04300	287.77	04300	211.43	04300
214.75	04400	287.77	04400	211.43	04400
214.75	04500	287.77	04500	211.43	04500
214.75	04600	287.77	04600	211.43	04600
214.75	04700	287.77	04700	211.43	04700
214.75	04800	287.77	04800	211.43	04800
214.75	04900	287.77	04900	211.43	04900
214.75	05000	287.77	05000	211.43	05000
214.75	05100	287.77	05100	211.43	05100
214.75	05200	287.77	05200	211.43	05200
214.75	05300	287.77	05300	211.43	05300
214.75	05400	287.77	05400	211.43	05400
214.75	05500	287.77	05500	211.43	05500
214.75	05600	287.77	05600	211.43	05600
214.75	05700	287.77	05700	211.43	05700
214.75	05800	287.77	05800	211.43	05800
214.75	05900	287.77	05900	211.43	05900
214.75	06000	287.77	06000	211.43	06000
246.71	06100	301.79	06100	292.22	06100
246.71	06200	301.79	06200	292.22	06200
246.71	06300	301.79	06300	292.22	06300
246.71	06400	301.79	06400	292.22	06400
246.71	06500	301.79	06500	292.22	06500
246.71	06600	301.79	06600	292.22	06600
246.71	06700	301.79	06700	292.22	06700
246.71	06800	301.79	06800	292.22	06800
246.71	06900	301.79	06900	292.22	06900
246.71	07000	301.79	07000	292.22	07000
246.71	07100	301.79	07100	292.22	07100
246.71	07200	301.79	07200	292.22	07200

P	●	●
M	●	●
K	●	●
N	○	●
S	●	●
H	●	○
O		

→ v_c Page 118–124

Ø DC_{m7} for Type Speed VA and Quattro 4F / Ø DC_{h7} for Type AL

WTX – High Performance Drill, factory standard

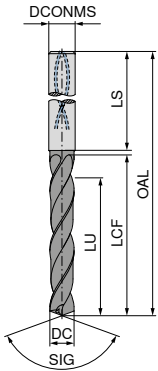
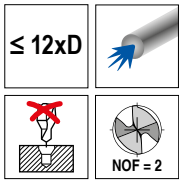

DC _{h7/m7}	DCONMS _{h6}	OAL	LCF	LU	LS
mm	mm	mm	mm	mm	mm
7.3	8	146	108	94	36
7.4	8	146	108	94	36
7.5	8	146	108	94	36
7.6	8	146	108	94	36
7.7	8	146	108	94	36
7.8	8	146	108	94	36
7.9	8	146	108	94	36
8.0	8	146	108	94	36
8.1	10	162	120	110	40
8.2	10	162	120	110	40
8.3	10	162	120	110	40
8.4	10	162	120	110	40
8.5	10	162	120	110	40
8.6	10	162	120	110	40
8.7	10	162	120	110	40
8.8	10	162	120	110	40
8.9	10	162	120	110	40
9.0	10	162	120	110	40
9.1	10	162	120	110	40
9.2	10	162	120	110	40
9.3	10	162	120	110	40
9.4	10	162	120	110	40
9.5	10	162	120	110	40
9.6	10	162	120	110	40
9.7	10	162	120	110	40
9.8	10	162	120	110	40
9.9	10	162	120	110	40
10.0	10	162	120	110	40
10.1	12	204	156	142	45
10.2	12	204	156	142	45
10.3	12	204	156	142	45
10.4	12	204	156	142	45
10.5	12	204	156	142	45
10.6	12	204	156	142	45
10.7	12	204	156	142	45
10.8	12	204	156	142	45
10.9	12	204	156	142	45
11.0	12	204	156	142	45
11.1	12	204	156	142	45
11.2	12	204	156	142	45
11.3	12	204	156	142	45
11.4	12	204	156	142	45
11.5	12	204	156	142	45

10 774 ...		10 737 ...		10 793 ...	
£	T4	£	T4	£	T4
246.71	07300	301.79	07300	292.22	07300
246.71	07400	301.79	07400	292.22	07400
246.71	07500	301.79	07500	292.22	07500
246.71	07600	301.79	07600	292.22	07600
246.71	07700	301.79	07700	292.22	07700
246.71	07800	301.79	07800	292.22	07800
246.71	07900	301.79	07900	292.22	07900
246.71	08000	301.79	08000	292.22	08000
321.75	08100	411.18	08100	370.99	08100
321.75	08200	411.18	08200	370.99	08200
321.75	08300	411.18	08300	370.99	08300
321.75	08400	411.18	08400	370.99	08400
321.75	08500	411.18	08500	370.99	08500
321.75	08600	411.18	08600	370.99	08600
321.75	08700	411.18	08700	370.99	08700
321.75	08800	411.18	08800	370.99	08800
321.75	08900	411.18	08900	370.99	08900
321.75	09000	411.18	09000	370.99	09000
321.75	09100	411.18	09100	370.99	09100
321.75	09200	411.18	09200	370.99	09200
321.75	09300	411.18	09300	370.99	09300
321.75	09400	411.18	09400	370.99	09400
321.75	09500	411.18	09500	370.99	09500
321.75	09600	411.18	09600	370.99	09600
321.75	09700	411.18	09700	370.99	09700
321.75	09800	411.18	09800	370.99	09800
321.75	09900	411.18	09900	370.99	09900
321.75	10000	411.18	10000	370.99	10000
438.53	10100	508.55	10100		
438.53	10200	508.55	10200	502.69	10200
438.53	10300	508.55	10300		
438.53	10400	508.55	10400		
438.53	10500	508.55	10500	502.69	10500
438.53	10600	508.55	10600		
438.53	10700	508.55	10700	502.69	10700
438.53	10800	508.55	10800	502.69	10800
438.53	10900	508.55	10900		
438.53	11000	508.55	11000	502.69	11000
438.53	11100	508.55	11100		
438.53	11200	508.55	11200	502.69	11200
438.53	11300	508.55	11300	502.69	11300
438.53	11400	508.55	11400		
438.53	11500	508.55	11500	502.69	11500

P	●	●
M	●	●
K	●	●
N	○	●
S	●	●
H	●	○
O		

→ v_c Page 118–124

Ø DC_{m7} for Type Speed VA and Quattro 4F / Ø DC_{h7} for Type AL

WTX – High Performance Drill, factory standard

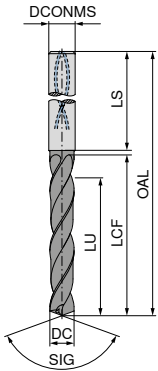
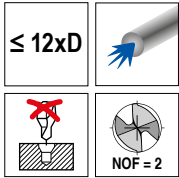

DC _{h7/m7}	DCONMS _{h6}	OAL	LCF	LU	LS
mm	mm	mm	mm	mm	mm
11.6	12	204	156	142	45
11.7	12	204	156	142	45
11.8	12	204	156	142	45
11.9	12	204	156	142	45
12.0	12	204	156	142	45
12.1	14	230	182	166	45
12.2	14	230	182	166	45
12.5	14	230	182	166	45
12.8	14	230	182	166	45
13.0	14	230	182	166	45
13.2	14	230	182	166	45
13.5	14	230	182	166	45
13.8	14	230	182	166	45
14.0	14	230	182	166	45
14.2	16	260	208	192	48
14.5	16	260	208	192	48
14.7	16	260	208	192	48
14.8	16	260	208	192	48
15.0	16	260	208	192	48
15.1	16	260	208	192	48
15.2	16	260	208	192	48
15.5	16	260	208	192	48
15.7	16	260	208	192	48
15.8	16	260	208	192	48
16.0	16	260	208	192	48
16.2	18	285	234	216	48
16.5	18	285	234	216	48
16.8	18	285	234	216	48
17.0	18	285	234	216	48
17.2	18	285	234	216	48
17.5	18	285	234	216	48
17.8	18	285	234	216	48
18.0	18	285	234	216	48
18.2	20	310	258	240	50
18.5	20	310	258	240	50
18.7	20	310	258	240	50
18.8	20	310	258	240	50
19.0	20	310	258	240	50
19.2	20	310	258	240	50
19.5	20	310	258	240	50
19.8	20	310	258	240	50
20.0	20	310	258	240	50

10 774 ...		10 737 ...		10 793 ...	
£	T4	£	T4	£	T4
438.53	11600	508.55	11700		
438.53	11700	508.55	11700		
438.53	11800	508.55	11800	502.69	11800
438.53	11900	508.55	11900		
438.53	12000	508.55	12000	502.69	12000
				708.55	12100
623.21	12200			708.55	12200
623.21	12500	743.59	12500	708.55	12500
623.21	12800	743.59	12800	708.55	12800
623.21	13000	743.59	13000	708.55	13000
				708.55	13200
623.21	13500	743.59	13500	708.55	13500
623.21	13800	743.59	13800	708.55	13800
623.21	14000	743.59	14000	708.55	14000
799.59	14200			859.09	14200
799.59	14500	971.76	14500	859.09	14500
				859.09	14700
		971.76	14800	859.09	14800
799.59	15000	971.76	15000	859.09	15000
799.59	15100				
799.59	15200			859.09	15200
799.59	15500	971.76	15500	859.09	15500
				859.09	15700
799.59	15800	971.76	15800	859.09	15800
799.59	16000	971.76	16000	859.09	16000
				955.55	16200
		1,342.35	16500	955.55	16500
		1,342.35	16800	955.55	16800
1,099.48	17000	1,342.35	17000	955.55	17000
				955.55	17200
1,099.48	17500	1,342.35	17500	955.55	17500
		1,342.35	17800	955.55	17800
		1,342.35	18000	955.55	18000
				1,209.93	18200
				1,209.93	18500
				1,209.93	18700
				1,209.93	18800
				1,209.93	19000
				1,209.93	19200
				1,209.93	19500
				1,209.93	19800
				1,209.93	20000

P	●	●
M	●	
K	●	●
N	○	●
S	●	
H		○
O		

→ v_c Page 118-124

Ø DC_{m7} for Type Speed VA and Quattro 4F / Ø DC_{h7} for Type AL

High Performance Drill, factory standard

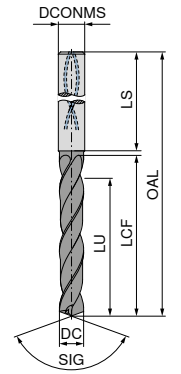
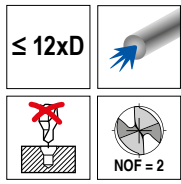

NEW
UNI
TiAIN



SIG 135°
Solid carbide

11 705 ...

DC _{h7} mm	DCONMS _{h6} mm	OAL mm	LCF mm	LU mm	LS mm	£ T1/9C	
3.0	6	92	54	49.5	36	95.54	03000
3.1	6	92	54	49.3	36	95.54	03100
3.2	6	92	54	49.2	36	95.54	03200
3.3	6	92	54	49.0	36	95.54	03300
3.4	6	92	54	48.9	36	95.54	03400
3.5	6	92	54	48.7	36	95.54	03500
3.6	6	92	54	48.6	36	95.54	03600
3.7	6	92	54	48.4	36	95.54	03700
3.8	6	102	64	58.3	36	95.54	03800
3.9	6	102	64	58.1	36	95.54	03900
4.0	6	102	64	58.0	36	95.54	04000
4.1	6	102	64	57.8	36	95.54	04100
4.2	6	102	64	57.7	36	95.54	04200
4.3	6	102	64	57.5	36	95.54	04300
4.4	6	102	64	57.4	36	95.54	04400
4.5	6	102	64	57.2	36	95.54	04500
4.6	6	102	64	57.1	36	95.54	04600
4.7	6	102	64	56.9	36	95.54	04700
4.8	6	116	78	70.8	36	95.54	04800
4.9	6	116	78	70.6	36	95.54	04900
5.0	6	116	78	70.5	36	95.54	05000
5.1	6	116	78	70.3	36	95.54	05100
5.2	6	116	78	70.2	36	95.54	05200
5.3	6	116	78	70.0	36	95.54	05300
5.4	6	116	78	69.9	36	95.54	05400
5.5	6	116	78	69.7	36	95.54	05500
5.6	6	116	78	69.6	36	95.54	05600
5.7	6	116	78	69.4	36	95.54	05700
5.8	6	116	78	69.3	36	95.54	05800
5.9	6	116	78	69.1	36	95.54	05900
6.0	6	116	78	69.0	36	95.54	06000
6.1	8	146	108	98.8	36	106.43	06100
6.2	8	146	108	98.7	36	106.43	06200
6.3	8	146	108	98.5	36	106.43	06300
6.4	8	146	108	98.4	36	106.43	06400
6.5	8	146	108	98.2	36	106.43	06500
6.6	8	146	108	98.1	36	106.43	06600
6.7	8	146	108	97.9	36	106.43	06700
6.8	8	146	108	97.8	36	106.43	06800
6.9	8	146	108	97.6	36	106.43	06900
7.0	8	146	108	97.5	36	106.43	07000
7.1	8	146	108	97.3	36	106.43	07100
7.2	8	146	108	97.2	36	106.43	07200
7.3	8	146	108	97.0	36	106.43	07300
7.4	8	146	108	96.9	36	106.43	07400

DC _{h7} mm	DCONMS _{h6} mm	OAL mm	LCF mm	LU mm	LS mm	£ T1/9C	
7.5	8	146	108	96.7	36	106.43	07500
7.6	8	146	108	96.6	36	106.43	07600
7.7	8	146	108	96.4	36	106.43	07700
7.8	8	146	108	96.3	36	106.43	07800
7.9	8	146	108	96.1	36	106.43	07900
8.0	8	146	108	96.0	36	106.43	08000
8.1	10	162	120	107.8	40	148.76	08100
8.2	10	162	120	107.7	40	148.76	08200
8.3	10	162	120	107.5	40	148.76	08300
8.4	10	162	120	107.4	40	148.76	08400
8.5	10	162	120	107.2	40	148.76	08500
8.6	10	162	120	107.1	40	148.76	08600
8.7	10	162	120	106.9	40	148.76	08700
8.8	10	162	120	106.8	40	148.76	08800
8.9	10	162	120	106.6	40	148.76	08900
9.0	10	162	120	106.5	40	148.76	09000
9.1	10	162	120	106.3	40	148.76	09100
9.2	10	162	120	106.2	40	148.76	09200
9.3	10	162	120	106.0	40	148.76	09300
9.4	10	162	120	105.9	40	148.76	09400
9.5	10	162	120	105.7	40	148.76	09500
9.6	10	162	120	105.6	40	148.76	09600
9.7	10	162	120	105.4	40	148.76	09700
9.8	10	162	120	105.3	40	148.76	09800
9.9	10	162	120	105.1	40	148.76	09900
10.0	10	162	120	105.0	40	148.76	10000
10.2	12	204	156	140.7	45	205.60	10200
10.5	12	204	156	140.2	45	205.60	10500
10.8	12	204	156	139.8	45	205.60	10800
11.0	12	204	156	139.5	45	205.60	11000
11.5	12	204	156	138.7	45	205.60	11500
11.8	12	204	156	138.3	45	205.60	11800
12.0	12	204	156	138.0	45	205.60	12000
12.5	14	230	182	163.2	45	264.86	12500
12.7	14	230	182	162.9	45	264.86	12700
12.8	14	230	182	162.8	45	264.86	12800
13.0	14	230	182	162.5	45	264.86	13000
13.5	14	230	182	161.7	45	264.86	13500
13.8	14	230	182	161.3	45	264.86	13800
14.0	14	230	182	161.0	45	264.86	14000
14.5	16	260	208	186.2	48	349.52	14500
14.8	16	260	208	185.8	48	349.52	14800
15.0	16	260	208	185.5	48	349.52	15000
15.5	16	260	208	184.7	48	349.52	15500
15.8	16	260	208	184.3	48	349.52	15800
16.0	16	260	208	184.0	48	349.52	16000
16.5	18	285	234	209.2	48	417.24	16500
17.0	18	285	234	208.5	48	417.24	17000
17.5	18	285	234	207.7	48	417.24	17500
18.0	18	285	234	207.0	48	417.24	18000
18.5	20	310	258	230.2	50	417.24	18500
19.0	20	310	258	229.5	50	417.24	19000
19.5	20	310	258	228.7	50	417.24	19500
20.0	20	310	258	228.0	50	417.24	20000

P	●
M	●
K	●
N	●
S	
H	
O	

→ v_c Page 131

WTX – High Feed Drill, factory standard

- ▲ Three fluted high-feed drill
- ▲ Universal application

- ▲ High positioning accuracy
- ▲ Suitable for difficult drilling applications

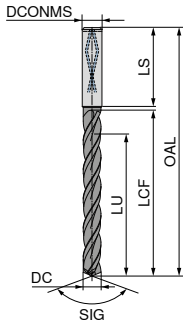
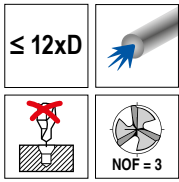

Feed UNI

DPX74S

DRAGONSKIN



SIG 135°
Solid carbide

10 796 ...

DC _{m7} mm	DCONMS _{h6} mm	OAL mm	LCF mm	LU mm	LS mm	£ T4	
4.0	6	102	64	58	36	242.39	04000
4.1	6	102	64	58	36	242.39	04100
4.2	6	102	64	58	36	242.39	04200
4.3	6	102	64	58	36	242.39	04300
4.4	6	102	64	58	36	242.39	04400
4.5	6	102	64	58	36	242.39	04500
4.6	6	102	64	58	36	242.39	04600
4.7	6	102	64	58	36	242.39	04700
4.8	6	116	78	70	36	242.39	04800
4.9	6	116	78	70	36	242.39	04900
5.0	6	116	78	70	36	242.39	05000
5.1	6	116	78	70	36	242.39	05100
5.2	6	116	78	70	36	242.39	05200
5.3	6	116	78	70	36	242.39	05300
5.4	6	116	78	70	36	242.39	05400
5.5	6	116	78	70	36	242.39	05500
5.6	6	116	78	70	36	242.39	05600
5.7	6	116	78	70	36	242.39	05700
5.8	6	116	78	70	36	242.39	05800
5.9	6	116	78	70	36	242.39	05900
6.0	6	116	78	70	36	242.39	06000
6.1	8	146	108	94	36	312.18	06100
6.2	8	146	108	94	36	312.18	06200
6.3	8	146	108	94	36	312.18	06300
6.4	8	146	108	94	36	312.18	06400
6.5	8	146	108	94	36	312.18	06500
6.6	8	146	108	94	36	312.18	06600
6.7	8	146	108	94	36	312.18	06700
6.8	8	146	108	94	36	312.18	06800
6.9	8	146	108	94	36	312.18	06900
7.0	8	146	108	94	36	312.18	07000
7.1	8	146	108	94	36	312.18	07100
7.2	8	146	108	94	36	312.18	07200
7.3	8	146	108	94	36	312.18	07300
7.4	8	146	108	94	36	312.18	07400
7.5	8	146	108	94	36	312.18	07500
7.6	8	146	108	94	36	312.18	07600
7.7	8	146	108	94	36	312.18	07700
7.8	8	146	108	94	36	312.18	07800
7.9	8	146	108	94	36	312.18	07900
8.0	8	146	108	94	36	312.18	08000
8.1	10	162	120	110	40	406.80	08100
8.2	10	162	120	110	40	406.80	08200
8.3	10	162	120	110	40	406.80	08300
8.4	10	162	120	110	40	406.80	08400
8.5	10	162	120	110	40	406.80	08500
8.6	10	162	120	110	40	406.80	08600
8.7	10	162	120	110	40	406.80	08700
8.8	10	162	120	110	40	406.80	08800
8.9	10	162	120	110	40	406.80	08900
9.0	10	162	120	110	40	406.80	09000
9.1	10	162	120	110	40	406.80	09100

10 796 ...

DC _{m7} mm	DCONMS _{h6} mm	OAL mm	LCF mm	LU mm	LS mm	£ T4	
9.2	10	162	120	110	40	406.80	09200
9.3	10	162	120	110	40	406.80	09300
9.4	10	162	120	110	40	406.80	09400
9.5	10	162	120	110	40	406.80	09500
9.6	10	162	120	110	40	406.80	09600
9.7	10	162	120	110	40	406.80	09700
9.8	10	162	120	110	40	406.80	09800
9.9	10	162	120	110	40	406.80	09900
10.0	10	162	120	110	40	406.80	10000
10.1	12	204	156	142	45	530.63	10100
10.2	12	204	156	142	45	530.63	10200
10.3	12	204	156	142	45	530.63	10300
10.4	12	204	156	142	45	530.63	10400
10.5	12	204	156	142	45	530.63	10500
10.6	12	204	156	142	45	530.63	10600
10.7	12	204	156	142	45	530.63	10700
10.8	12	204	156	142	45	530.63	10800
10.9	12	204	156	142	45	530.63	10900
11.0	12	204	156	142	45	530.63	11000
11.1	12	204	156	142	45	530.63	11100
11.2	12	204	156	142	45	530.63	11200
11.3	12	204	156	142	45	530.63	11300
11.4	12	204	156	142	45	530.63	11400
11.5	12	204	156	142	45	530.63	11500
11.6	12	204	156	142	45	530.63	11600
11.7	12	204	156	142	45	530.63	11700
11.8	12	204	156	142	45	530.63	11800
11.9	12	204	156	142	45	530.63	11900
12.0	12	204	156	142	45	530.63	12000
12.2	14	230	182	166	45	680.21	12200
12.5	14	230	182	166	45	680.21	12500
12.8	14	230	182	166	45	680.21	12800
13.0	14	230	182	166	45	680.21	13000
13.5	14	230	182	166	45	680.21	13500
13.8	14	230	182	166	45	680.21	13800
14.0	14	230	182	166	45	680.21	14000
14.5	16	260	208	192	48	884.36	14500
14.8	16	260	208	192	48	884.36	14800
15.0	16	260	208	192	48	884.36	15000
15.5	16	260	208	192	48	884.36	15500
15.8	16	260	208	192	48	884.36	15800
16.0	16	260	208	192	48	884.36	16000
16.5	18	285	234	216	48	1,141.45	16500
16.8	18	285	234	216	48	1,141.45	16800
17.0	18	285	234	216	48	1,141.45	17000
17.5	18	285	234	216	48	1,141.45	17500
17.8	18	285	234	216	48	1,141.45	17800
18.0	18	285	234	216	48	1,141.45	18000
18.5	20	310	258	240	50	1,395.62	18500
18.8	20	310	258	240	50	1,395.62	18800
19.0	20	310	258	240	50	1,395.62	19000
19.5	20	310	258	240	50	1,395.62	19500
19.8	20	310	258	240	50	1,395.62	19800
20.0	20	310	258	240	50	1,395.62	20000

P	●
M	●
K	●
N	○
S	
H	
O	

→ v_c Page 113

WTX – Co-pilot deep hole twist drills

- ▲ Cutting tolerance j6 optimally coordinated as an intermediate tolerance between the pilot drill and deep hole twist drill
- ▲ For optimal guidance and reduction of the cutting time of the deep hole twist drill for hole depths > 30xD
- ▲ Pilot hole necessary
- ▲ up to 20xD without peck drilling
- ▲ Excellent alignment precision
- ▲ Reliable chip removal

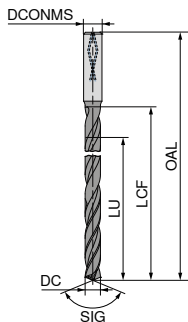
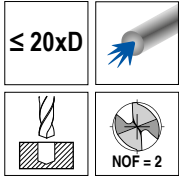

CP 20
UNI
TiAlN



SIG 137°
Solid carbide

11 018 ...

£
T7

DC j6 mm	DCONMS _{HS} mm	OAL mm	LCF mm	LU mm	
3.0	6	120	80	60	213.57 03000
4.0	6	130	90	80	222.37 04000
4.2	6	160	110	84	240.75 04200
4.5	6	160	110	90	240.75 04500
4.8	6	160	120	96	256.22 04800
5.0	6	160	120	100	256.22 05000
5.5	6	185	140	110	266.09 05500
5.8	6	185	140	116	266.09 05800
6.0	6	185	140	120	266.09 06000
6.5	8	210	160	130	303.95 06500
6.8	8	210	160	136	303.95 06800
7.0	8	210	160	140	303.95 07000
7.5	8	230	180	150	337.81 07500
7.8	8	230	180	156	337.81 07800
8.0	8	230	180	160	337.81 08000
8.5	10	260	195	170	372.87 08500
8.8	10	290	230	176	416.47 08800
9.0	10	290	230	180	416.47 09000

P	●
M	●
K	●
N	●
S	○
H	
O	

Tolerances and angles

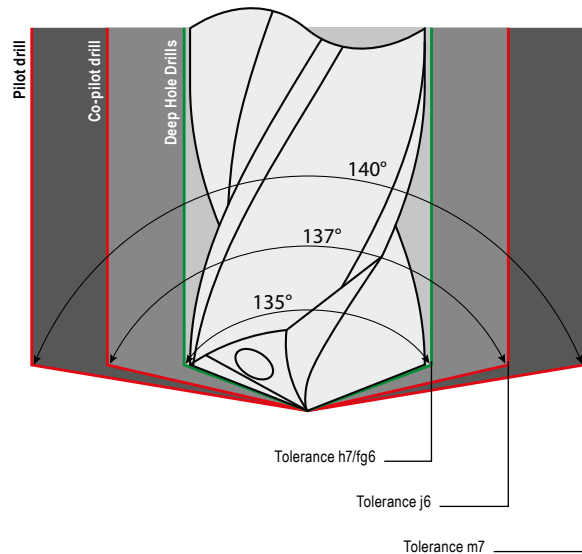

Tolerance table

ISO tolerances for shafts and holes

of Ø	3	6	10	18	
up to and including	6	10	18	30	
p6	20	24	29	35	
	12	15	18	22	
h7	0	0	0	0	Deep hole twist drill 16xD to 30xD
	-12	-15	-18	-21	
j6	6	7	8	9	Co-pilot drill
	-2	-2	-3	-4	
fg6	-6	-8			Deep hole twist drill > 30xD
	-14	-17			
m6	12	15	18	21	
	4	6	7	8	
m7	16	21	25	29	WTX UNI / WTX VA
	4	6	7	8	

WTX – High performance deep hole drills

- ▲ up to 16xD without peck drilling
- ▲ pilot hole necessary
- ▲ excellent alignment precision
- ▲ secure chip evacuation

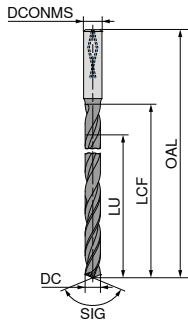
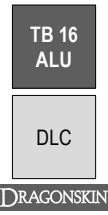
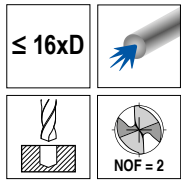

SIG 135°
Solid carbide

11 016 ...

DC _{h7} mm	DCONMS _{h6} mm	OAL mm	LCF mm	LU mm	£ T7	
2.0	4	84	42	39	127.36	020
2.2	4	84	42	39	127.36	022
2.3	4	84	42	39	127.36	023
2.4	4	96	54	50	142.17	024
2.5	4	96	54	50	142.17	025
2.7	4	96	54	50	142.17	027
2.8	4	96	54	50	142.17	028
3.0	6	100	60	55	180.66	030
3.2	6	100	60	55	180.66	032
3.3	6	100	60	55	180.66	033
3.5	6	100	60	55	180.66	035
3.8	6	115	75	69	188.08	038
4.0	6	115	75	69	188.08	040
4.2	6	115	75	69	202.88	042
4.5	6	130	90	83	202.88	045
4.8	6	130	90	83	214.71	048
5.0	6	130	90	83	214.71	050
5.5	6	150	108	99	223.60	055
5.8	6	150	108	99	223.60	058
6.0	6	150	108	99	223.60	060
6.5	8	165	125	115	238.42	065
6.8	8	165	125	115	256.20	068
7.0	8	165	125	115	256.20	070
7.5	8	180	140	128	287.29	075
7.8	8	180	140	128	287.29	078
8.0	8	180	140	128	287.29	080
8.5	10	205	160	147	316.89	085
8.8	10	205	160	147	352.45	088
9.0	10	205	160	147	352.45	090
9.8	10	225	180	165	352.45	098
10.0	10	225	180	165	352.45	100
10.2	12	240	190	174	393.91	102
10.8	12	240	190	174	393.91	108
11.8	12	265	215	197	393.91	118
12.0	12	265	215	197	393.91	120

P	●
M	●
K	●
N	●
S	○
H	○
O	○

→ v_c Page 143+146
→ Machining information: Page 160

WTX – High performance deep hole drills

- ▲ up to 20xD without peck drilling
- ▲ pilot hole necessary
- ▲ excellent alignment precision
- ▲ secure chip evacuation

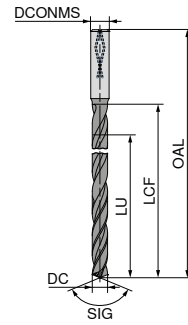
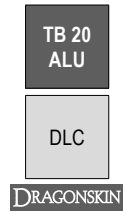
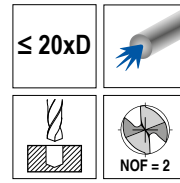

SIG 135°
Solid carbide

11 020 ...

DC _{h7} mm	DCONMS _{h6} mm	OAL mm	LCF mm	LU mm	£ T7	
2.0	4	92	50	47	134.75	020
2.2	4	92	50	47	130.19	022
2.3	4	92	50	47	134.75	023
2.4	4	112	70	66	145.94	024
2.5	4	112	70	66	151.04	025
2.7	4	112	70	66	145.94	027
2.8	4	112	70	66	151.04	028
3.0	6	120	80	75	194.58	030
3.2	6	120	80	75	201.40	032
3.3	6	120	80	75	194.58	033
3.5	6	120	80	75	201.40	035
3.8	6	130	90	84	203.16	038
4.0	6	130	90	84	210.26	040
4.2	6	160	110	103	217.46	042
4.5	6	160	110	103	225.09	045
4.8	6	160	120	113	230.34	048
5.0	6	160	120	113	238.42	050
5.5	6	185	140	131	240.37	055
5.8	6	185	140	131	248.80	058
6.0	6	185	140	131	248.80	060
6.5	8	210	160	150	265.08	065
6.8	8	210	160	150	285.81	068
7.0	8	210	160	150	285.81	070
7.5	8	230	180	168	318.38	075
7.8	8	230	180	168	318.38	078
8.0	8	230	180	168	318.38	080
8.5	10	260	195	182	350.95	085
8.8	10	290	230	216	393.91	088
9.0	10	290	230	216	393.91	090
9.8	10	290	230	216	393.91	098
10.0	10	290	230	216	393.91	100
10.2	12	315	268	251	432.41	102
10.8	12	315	268	251	432.41	108
11.8	12	315	268	251	432.41	118
12.0	12	315	268	251	432.41	120

P	●
M	●
K	●
N	●
S	○
H	○
O	○

→ v_c Page 143+146
→ Machining information: Page 160

WTX – High performance deep hole drills

- ▲ up to 25xD without peck drilling
- ▲ pilot hole necessary
- ▲ excellent alignment precision
- ▲ secure chip evacuation

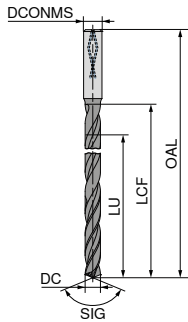
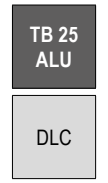
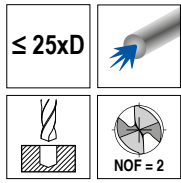

SIG 135°
Solid carbide

SIG 135°
Solid carbide

11 025 ...

11 026 ...

DC _{h7}	DCONMS _{h6}	OAL	LCF	LU	£	T7
2.0	4	104	60	57	143.65	020
2.2	4	104	60	57	143.65	022
2.3	4	104	60	57	143.65	023
2.4	4	125	80	76	162.89	024
2.5	4	125	80	76	162.89	025
2.7	4	125	80	76	162.89	027
2.8	4	125	80	76	162.89	028
3.0	6	135	98	93	233.96	030
3.2	6	135	98	93	233.96	032
3.3	6	150	110	105	259.13	033
3.5	6	150	110	105	259.13	035
3.8	6	160	120	114	266.55	038
4.0	6	160	120	114	266.55	040
4.2	6	160	120	114	266.55	042
4.5	6	180	135	128	278.40	045
4.8	6	180	135	128	278.40	048
5.0	6	180	135	128	278.40	050
5.5	6	205	168	159	299.14	055
5.8	6	205	168	159	299.14	058
6.0	6	205	168	159	299.14	060
6.5	8	240	200	190	333.21	065
6.8	8	240	200	190	333.21	068
7.0	8	240	200	190	333.21	070
7.5	8	260	220	208	370.22	075
7.8	8	260	220	208	370.22	078
8.0	8	260	220	208	370.22	080
8.5	10	285	240	227	417.57	085
8.8	10	310	268	254	453.13	088
9.0	10	310	268	254	453.13	090
9.8	10	310	268	254	453.13	098
10.0	10	310	268	254	453.13	100
10.2	12	375	325	308	544.96	102
10.8	12	375	325	308	544.96	108
11.8	12	375	325	308	544.96	118
12.0	12	375	325	308	544.96	120

P	●
M	●
K	●
N	●
S	○
H	
O	

→ v_c Page 144+147
→ Machining information: Page 160

WTX – High performance deep hole drills

- ▲ up to 30xD without peck drilling
- ▲ pilot hole necessary
- ▲ excellent alignment precision
- ▲ secure chip evacuation

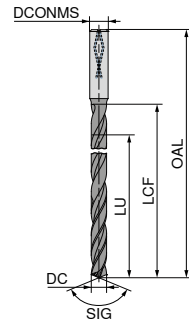
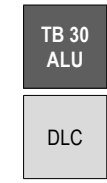
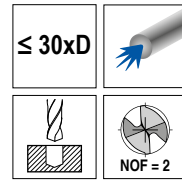

SIG 135°
Solid carbide

SIG 135°
Solid carbide

11 030 ...

11 031 ...

DC _{h7}	DCONMS _{h6}	OAL	LCF	LU	£	T7
2.0	4	115	70	67	152.55	020
2.2	4	115	70	67	152.55	022
2.3	4	115	70	67	152.55	023
2.4	4	138	90	86	177.71	024
2.5	4	138	90	86	177.71	025
2.7	4	138	90	86	177.71	027
2.8	4	138	90	86	177.71	028
3.0	6	150	105	100	299.14	030
3.2	6	150	105	100	299.14	032
3.3	6	185	135	130	308.03	033
3.5	6	185	135	130	308.03	035
3.8	6	185	135	130	308.03	038
4.0	6	185	135	130	308.03	040
4.2	6	185	135	130	308.03	042
4.5	6	215	165	158	316.89	045
4.8	6	215	165	158	316.89	048
5.0	6	215	165	158	316.89	050
5.5	6	230	180	171	331.71	055
5.8	6	230	180	171	331.71	058
6.0	6	230	180	171	331.71	060
6.5	8	280	215	205	364.28	065
6.8	8	280	230	220	380.56	068
7.0	8	280	230	220	380.56	070
7.5	8	280	230	220	380.56	075
7.8	8	315	265	253	423.52	078
8.0	8	315	265	253	423.52	080
8.5	10	350	295	282	488.69	085
8.8	10	380	330	316	513.84	088
9.0	10	380	330	316	513.84	090
9.8	10	380	330	316	513.84	098
10.0	10	380	330	316	513.84	100
10.2	12	430	380	365	656.02	102
10.8	12	430	380	365	656.02	108
11.8	12	430	380	365	656.02	118
12.0	12	430	380	365	656.02	120

P	●
M	●
K	●
N	●
S	○
H	
O	

→ v_c Page 144+147
→ Machining information: Page 160

WTX – High performance deep hole drills

- ▲ up to 40xD without peck drilling
- ▲ pilot hole necessary
- ▲ excellent alignment precision
- ▲ secure chip evacuation

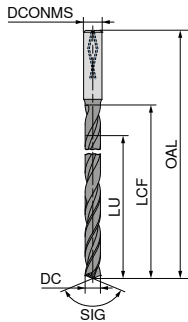
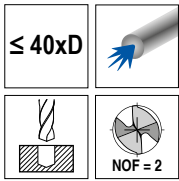

SIG 135°
Solid carbide

11 040 ...

DC _{fg6} mm	DCONMS _{h6} mm	OAL mm	LCF mm	LU mm	£ T7	
3.0	6	195	150	146	380.56	030
4.0	6	220	175	169	380.56	040
4.2	6	245	200	194	420.57	042
4.5	6	245	200	194	420.57	045
4.8	6	275	230	223	448.70	048
5.0	6	275	230	223	448.70	050
5.5	6	305	260	251	482.76	055
5.8	6	305	260	251	482.76	058
6.0	6	305	260	251	482.76	060
6.5	8	345	300	290	519.78	065
6.8	8	345	300	290	519.78	068
7.0	8	345	300	290	519.78	070
7.5	8	385	340	328	577.53	075
7.8	8	385	340	328	577.53	078
8.0	8	385	340	328	577.53	080
8.5	10	430	380	367	636.76	085
8.8	10	430	380	367	636.76	088
9.0	10	430	380	367	636.76	090

P	●
M	●
K	●
N	●
S	○
H	
O	

→ v_c Page 145
→ Machining information: Page 160

WTX – High performance deep hole drills

- ▲ up to 50xD without peck drilling
- ▲ pilot hole necessary
- ▲ excellent alignment precision
- ▲ secure chip evacuation

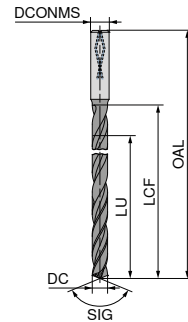
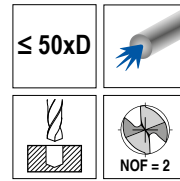

SIG 135°
Solid carbide

11 050 ...

DC _{fg6} mm	DCONMS _{h6} mm	OAL mm	LCF mm	LU mm	£ T7	
3.0	6	220	175	170	516.83	030
4.0	6	265	220	214	516.83	040
4.2	6	290	245	238	574.55	042
4.5	6	290	245	238	574.55	045
4.8	6	320	275	268	648.61	048
5.0	6	320	275	268	648.61	050
5.5	6	355	310	302	730.06	055
5.8	6	355	315	306	740.43	058
6.0	6	355	315	306	740.43	060
6.5	8	395	350	340	823.36	065
6.8	8	425	380	370	892.96	068

P	●
M	●
K	●
N	●
S	○
H	
O	

→ v_c Page 145
→ Machining information: Page 160

The deep hole twist drills are also available in other dimensions on request.

WTX – High Performance Drills

▲ standard shank Ø 3 mm h6 for use in heat shrink adapters

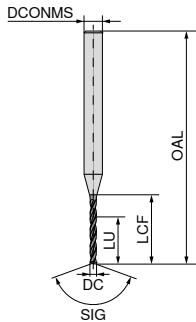
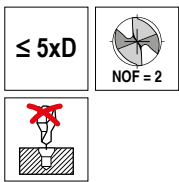

MINI
TiAIN

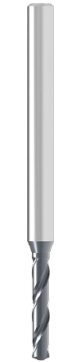

SIG 140°
Solid carbide

DC ^{+0,004} mm	DCONMS _{h6} mm	OAL mm	LCF mm	LU mm	£ T7	11 770 ...
0.10	3	38	1.2	1.0	48.20	00100
0.15	3	38	2.0	1.7	42.57	00150
0.20	3	38	3.5	3.0	37.22	00200
0.25	3	38	3.5	3.0	31.71	00250
0.30	3	38	5.5	5.0	26.08	00300
0.35	3	38	5.5	5.0	26.08	00350
0.40	3	38	7.0	6.0	26.08	00400
0.45	3	38	7.0	6.0	26.08	00450
0.50	3	38	7.0	6.0	26.08	00500
0.55	3	38	7.0	6.0	26.08	00550
0.60	3	38	7.0	6.0	26.08	00600
0.65	3	38	7.0	6.0	26.08	00650
0.70	3	38	10.5	8.0	26.08	00700
0.75	3	38	10.5	8.0	26.08	00750
0.80	3	38	10.5	8.0	26.08	00800
0.85	3	38	10.5	8.0	26.08	00850
0.90	3	38	10.5	8.0	26.08	00900
0.95	3	38	10.5	8.0	26.08	00950
0.97	3	38	10.5	8.0	26.08	00970
0.98	3	38	10.5	8.0	26.08	00980
0.99	3	38	10.5	8.0	26.08	00990
1.00	3	38	10.5	8.0	26.08	01000
1.01	3	38	10.5	8.0	26.08	01010
1.02	3	38	10.5	8.0	26.08	01020
1.03	3	38	10.5	8.0	26.08	01030
1.05	3	38	10.5	8.0	26.08	01050
1.10	3	38	10.5	8.0	26.08	01100
1.15	3	38	10.5	8.0	26.08	01150
1.20	3	38	10.5	8.0	26.08	01200
1.25	3	38	10.5	8.0	26.08	01250
1.30	3	38	10.5	8.0	26.08	01300
1.35	3	38	10.5	8.0	26.08	01350
1.40	3	38	10.5	8.0	26.08	01400
1.45	3	38	10.5	8.0	26.08	01450
1.47	3	38	10.5	8.0	26.08	01470
1.48	3	38	10.5	8.0	26.08	01480
1.49	3	38	10.5	8.0	26.08	01490
1.50	3	38	10.5	8.0	26.08	01500
1.51	3	38	10.5	8.0	26.08	01510
1.52	3	38	10.5	8.0	26.08	01520
1.53	3	38	10.5	8.0	26.08	01530
1.55	3	38	10.5	8.0	26.08	01550
1.60	3	38	10.5	8.0	26.08	01600
1.65	3	38	10.5	8.0	26.08	01650
1.70	3	38	10.5	8.0	26.08	01700
1.75	3	38	10.5	8.0	26.08	01750

DC ^{+0,004} mm	DCONMS _{h6} mm	OAL mm	LCF mm	LU mm	£ T7	11 770 ...
1.80	3	38	10.5	8.0	26.08	01800
1.85	3	38	12.0	8.0	26.08	01850
1.90	3	38	12.0	8.0	26.08	01900
1.95	3	38	12.0	8.0	26.08	01950
1.97	3	38	12.0	8.0	26.08	01970
1.98	3	38	12.0	8.0	26.08	01980
1.99	3	38	12.0	8.0	26.08	01990
2.00	3	42	13.0	9.0	37.39	02000
2.01	3	42	13.0	9.0	37.39	02010
2.02	3	42	13.0	9.0	37.39	02020
2.03	3	42	13.0	9.0	37.39	02030
2.05	3	42	13.0	9.0	37.39	02050
2.10	3	42	13.0	9.0	37.39	02100
2.15	3	42	13.0	9.0	37.39	02150
2.20	3	46	15.0	10.0	42.10	02200
2.25	3	46	15.0	10.0	42.10	02250
2.30	3	46	15.0	10.0	42.10	02300
2.35	3	46	15.0	10.0	42.10	02350
2.40	3	46	15.0	10.0	42.10	02400
2.45	3	46	15.0	10.0	42.10	02450
2.47	3	46	15.0	10.0	42.10	02470
2.48	3	46	15.0	10.0	42.10	02480
2.49	3	46	15.0	10.0	42.10	02490
2.50	3	46	15.0	10.0	42.10	02500
2.51	3	46	15.0	10.0	42.10	02510
2.52	3	46	15.0	10.0	42.10	02520
2.53	3	46	15.0	10.0	42.10	02530
2.60	3	46	15.0	10.0	42.10	02600
2.70	3	46	15.0	10.0	42.10	02700
2.80	3	46	15.0	10.0	42.10	02800
2.90	3	46	15.0	10.0	42.10	02900

P	○
M	
K	●
N	●
S	○
H	
O	

→ v. Page 136

WTX – High Performance Drills

- ▲ Specialised micro drill
- ▲ Universal application
- ▲ Extremely high process security
- ▲ Pilot drill for WTX – Micro – high-performance deep hole drill

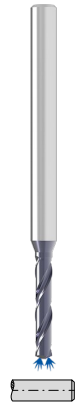
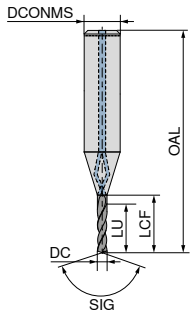
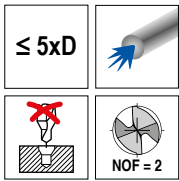

SIG 135°
Solid carbide

10 693 ...

DC _{ms} mm	DCONMS _{ms} mm	OAL mm	LCF mm	LU mm	£ T4	
0.8	3	39	5.6	4.0	116.12	00800
0.9	3	39	6.3	4.5	116.12	00900
1.0	3	40	7.0	5.0	103.08	01000
1.1	3	41	7.7	5.5	103.08	01100
1.2	3	41	8.4	6.0	103.08	01200
1.3	3	42	9.1	6.5	103.08	01300
1.4	3	42	9.8	7.0	103.08	01400
1.5	3	43	10.5	7.5	103.08	01500
1.6	3	44	11.2	8.0	108.52	01600
1.7	3	44	11.9	8.5	108.52	01700
1.8	3	45	12.6	9.0	108.52	01800
1.9	3	45	13.3	9.5	108.52	01900
2.0	3	46	14.0	10.0	108.52	02000
2.1	3	47	14.7	10.5	111.85	02100
2.2	3	47	15.4	11.0	111.85	02200
2.3	3	48	16.1	11.5	111.85	02300
2.4	3	48	16.8	12.0	111.85	02400
2.5	3	49	17.5	12.5	111.85	02500
2.6	3	50	18.2	13.0	117.76	02600
2.7	3	50	18.9	13.5	117.76	02700
2.8	3	51	19.6	14.0	117.76	02800
2.9	3	51	20.3	14.5	117.76	02900

P	●
M	●
K	●
N	●
S	○
H	
O	

→ v_c Page 137
→ Machining information: Page 161

Minimum coolant pressure: 30 bar

WTX – High Performance Drills

- ▲ Specialised micro drill
- ▲ Universal application
- ▲ Extremely high process security

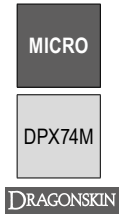
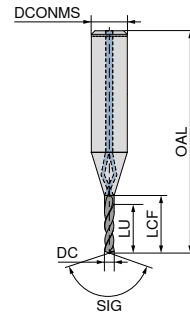
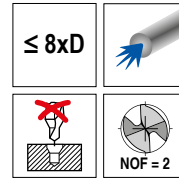

SIG 128°
Solid carbide

10 694 ...

DC _{ms} mm	DCONMS _{ms} mm	OAL mm	LCF mm	LU mm	£ T4	
0.8	3	41	8	6.4	121.80	00800
0.9	3	42	9	7.2	121.80	00900
1.0	3	43	10	8.0	108.70	01000
1.1	3	44	11	8.8	108.70	01100
1.2	3	45	12	9.6	108.70	01200
1.3	3	46	13	10.4	108.70	01300
1.4	3	47	14	11.2	108.70	01400
1.5	3	47	15	12.0	108.70	01500
1.6	3	48	16	12.8	116.93	01600
1.7	3	49	17	13.6	116.93	01700
1.8	3	50	18	14.4	116.93	01800
1.9	3	51	19	15.2	116.93	01900
2.0	3	52	20	16.0	116.93	02000
2.1	3	53	21	16.8	118.79	02100
2.2	3	54	22	17.6	118.79	02200
2.3	3	55	23	18.4	118.79	02300
2.4	3	56	24	19.2	118.79	02400
2.5	3	56	25	20.0	118.79	02500
2.6	3	57	26	20.8	122.61	02600
2.7	3	58	27	21.6	122.61	02700
2.8	3	59	28	22.4	122.61	02800
2.9	3	60	29	23.2	122.61	02900

P	●
M	●
K	●
N	●
S	○
H	
O	

→ v_c Page 138
→ Machining information: Page 161

Minimum coolant pressure: 30 bar

WTX – High Performance Drills

- ▲ Specialised micro drill
- ▲ Universal application
- ▲ Extremely high process security
- ▲ Pilot drill: 5xD WTX – Micro – high-performance drill

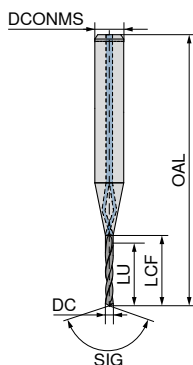
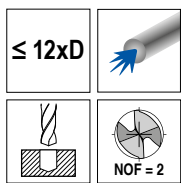

SIG 128°
Solid carbide

10 695 ...

DC _{h6} mm	DCONMS _{h6} mm	OAL mm	LCF mm	LU mm	£ T4	
0.8	3	44	11.2	9.6	135.65	00800
0.9	3	46	12.6	10.8	135.65	00900
1.0	3	47	14.0	12.0	122.61	01000
1.1	3	48	15.4	13.2	122.61	01100
1.2	3	50	16.8	14.4	122.61	01200
1.3	3	51	18.2	15.6	122.61	01300
1.4	3	52	19.6	16.8	122.61	01400
1.5	3	53	21.0	18.0	122.61	01500
1.6	3	55	22.4	19.2	129.07	01600
1.7	3	56	23.8	20.4	129.07	01700
1.8	3	57	25.2	21.6	129.07	01800
1.9	3	59	26.6	22.8	129.07	01900
2.0	3	60	28.0	24.0	129.07	02000
2.1	3	61	29.4	25.2	131.96	02100
2.2	3	63	30.8	26.4	131.96	02200
2.3	3	64	32.2	27.6	131.96	02300
2.4	3	65	33.6	28.8	131.96	02400
2.5	3	67	35.0	30.0	131.96	02500
2.6	3	68	36.4	31.2	134.71	02600
2.7	3	69	37.8	32.4	134.71	02700
2.8	3	70	39.2	33.6	134.71	02800
2.9	3	72	40.6	34.8	134.71	02900

P	●
M	●
K	●
N	
S	○
H	
O	

→ v_c Page 138
→ Machining information: Page 161

Minimum coolant pressure: 30 bar

WTX – High performance deep hole drills

- ▲ Specialised micro deep hole drill
- ▲ Universal application
- ▲ Extremely high process security
- ▲ Pilot drill: 5xD WTX – Micro – high-performance drill

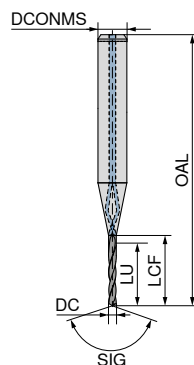
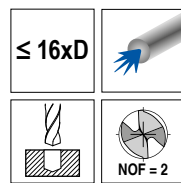

SIG 128°
Solid carbide

10 696 ...

DC _{h6} mm	DCONMS _{h6} mm	OAL mm	LCF mm	LU mm	£ T4	
0.8	3	48	14.4	12.8	172.47	00800
0.9	3	49	16.2	14.4	172.47	00900
1.0	3	51	18.0	16.0	159.43	01000
1.1	3	53	19.8	17.6	159.43	01100
1.2	3	54	21.6	19.2	159.43	01200
1.3	3	56	23.4	20.8	159.43	01300
1.4	3	58	25.2	22.4	159.43	01400
1.5	3	60	27.0	24.0	159.43	01500
1.6	3	61	28.8	25.6	167.85	01600
1.7	3	63	30.6	27.2	167.85	01700
1.8	3	65	32.4	28.8	167.85	01800
1.9	3	66	34.2	30.4	167.85	01900
2.0	3	68	36.0	32.0	167.85	02000
2.1	3	70	37.8	33.6	171.43	02100
2.2	3	71	39.6	35.2	171.43	02200
2.3	3	73	41.4	36.8	171.43	02300
2.4	3	75	43.2	38.4	171.43	02400
2.5	3	77	45.0	40.0	171.43	02500
2.6	3	78	46.8	41.6	175.13	02600
2.7	3	80	48.6	43.2	175.13	02700
2.8	3	82	50.4	44.8	175.13	02800
2.9	3	83	52.2	46.4	175.13	02900

P	●
M	●
K	●
N	
S	
H	
O	

→ v_c Page 139
→ Machining information: Page 161

Minimum coolant pressure: 30 bar

WTX – High performance deep hole drills

- ▲ Specialised micro deep hole drill
- ▲ Universal application
- ▲ Extremely high process security
- ▲ Pilot drill: 5xD WTX – Micro – high-performance drill

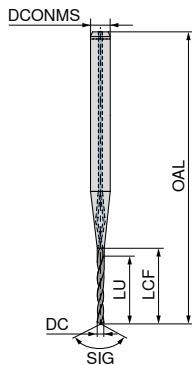
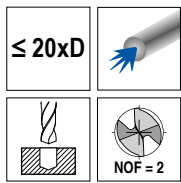

SIG 128°
Solid carbide

10 697 ...

DC _{h6} mm	DCONMS _{h6} mm	OAL mm	LCF mm	LU mm	£ T4	
0.8	3	51	17.6	16	189.55	00800
0.9	3	53	19.8	18	189.55	00900
1.0	3	55	22.0	20	176.51	01000
1.1	3	57	24.2	22	176.51	01100
1.2	3	59	26.4	24	176.51	01200
1.3	3	61	28.6	26	176.51	01300
1.4	3	63	30.8	28	176.51	01400
1.5	3	66	33.0	30	176.51	01500
1.6	3	68	35.2	32	185.86	01600
1.7	3	70	37.4	34	185.86	01700
1.8	3	72	39.6	36	185.86	01800
1.9	3	74	41.8	38	185.86	01900
2.0	3	76	44.0	40	185.86	02000
2.1	3	78	46.2	42	189.78	02100
2.2	3	80	48.4	44	189.78	02200
2.3	3	82	50.6	46	189.78	02300
2.4	3	85	52.8	48	189.78	02400
2.5	3	87	55.0	50	189.78	02500
2.6	3	89	57.2	52	193.95	02600
2.7	3	91	59.4	54	193.95	02700
2.8	3	93	61.6	56	193.95	02800
2.9	3	95	63.8	58	193.95	02900

P	●
M	●
K	●
N	
S	
H	
O	

→ v_c Page 139
→ Machining information: Page 161

Minimum coolant pressure: 30 bar

WTX – High performance deep hole drills

- ▲ Specialised micro deep hole drill
- ▲ Universal application
- ▲ Extremely high process security
- ▲ Pilot drill: 5xD WTX – Micro – high-performance drill

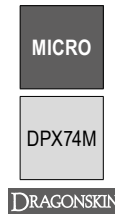
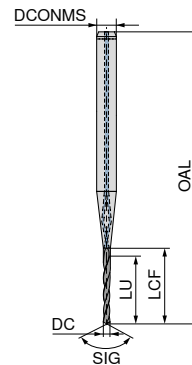
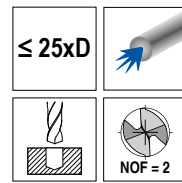

SIG 128°
Solid carbide

10 698 ...

DC _{h6} mm	DCONMS _{h6} mm	OAL mm	LCF mm	LU mm	£ T4	
0.8	3	54	21.6	16.0	217.21	00800
0.9	3	57	24.3	20.5	217.21	00900
1.0	3	60	27.0	25.0	195.33	01000
1.1	3	63	29.7	27.5	195.33	01100
1.2	3	65	32.4	30.0	195.33	01200
1.3	3	68	35.1	32.5	195.33	01300
1.4	3	71	37.8	35.0	195.33	01400
1.5	3	73	40.5	37.5	195.33	01500
1.6	3	76	43.2	40.0	205.72	01600
1.7	3	78	45.9	42.5	205.72	01700
1.8	3	81	48.6	45.0	205.72	01800
1.9	3	84	51.3	47.5	205.72	01900
2.0	3	86	54.0	50.0	205.72	02000
2.1	3	89	56.7	52.5	210.10	02100
2.2	3	91	59.4	55.0	210.10	02200
2.3	3	94	62.1	57.5	210.10	02300
2.4	3	97	64.8	60.0	210.10	02400
2.5	3	99	67.5	62.5	210.10	02500
2.6	3	102	70.2	65.0	214.60	02600
2.7	3	104	72.9	67.5	214.60	02700
2.8	3	107	75.6	70.0	214.60	02800
2.9	3	110	78.3	72.5	214.60	02900

P	●
M	●
K	●
N	
S	
H	
O	

→ v_c Page 139
→ Machining information: Page 161

Minimum coolant pressure: 30 bar

WTX – High performance deep hole drills

- ▲ Specialised micro deep hole drill
- ▲ Universal application
- ▲ Extremely high process security
- ▲ Pilot drill: 5xD WTX – Micro – high-performance drill

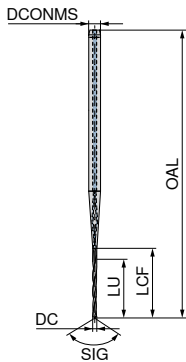
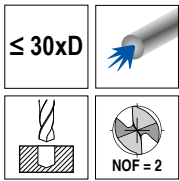

Tolerances and angles

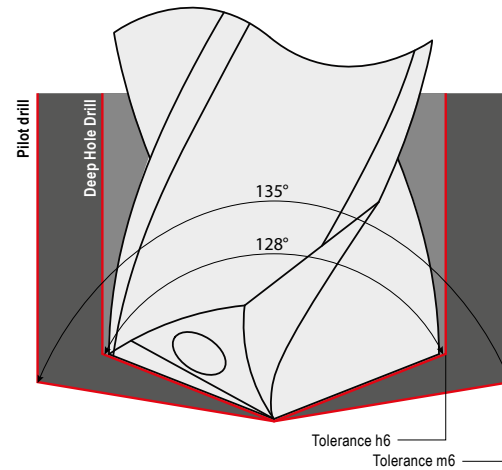

DC _{h6} mm	DCONMS _{h6} mm	OAL mm	LCF mm	LU mm	£	
0.8	3	59	25.6	19.2	240.51	00800
0.9	3	62	28.8	24.5	240.51	00900
1.0	3	65	32.0	30.0	216.22	01000
1.1	3	68	35.2	33.0	216.22	01100
1.2	3	71	38.4	36.0	216.22	01200
1.3	3	74	41.6	39.0	216.22	01300
1.4	3	78	44.8	42.0	216.22	01400
1.5	3	81	48.0	45.0	216.22	01500
1.6	3	84	51.2	48.0	227.77	01600
1.7	3	87	54.4	51.0	227.77	01700
1.8	3	90	57.6	54.0	227.77	01800
1.9	3	93	60.8	57.0	227.77	01900
2.0	3	96	64.0	60.0	227.77	02000
2.1	3	99	67.2	63.0	232.62	02100
2.2	3	102	70.4	66.0	232.62	02200
2.3	3	106	73.6	69.0	232.62	02300
2.4	3	109	76.8	72.0	232.62	02400
2.5	3	112	80.0	75.0	232.62	02500
2.6	3	115	83.2	78.0	237.57	02600
2.7	3	118	86.4	81.0	237.57	02700
2.8	3	121	89.6	84.0	237.57	02800
2.9	3	124	92.8	87.0	237.57	02900

P	●
M	●
K	●
N	
S	
H	
O	

→ v_c Page 139

→ Machining information: Page 161

Minimum coolant pressure: 30 bar

NEW

Coolant transfer pipe with strainer

HSK-A 63 / HSK-A 100

With the help of the new coolant transfer pipe, it is possible to filter very small chips and impurities out of the coolant. More information on this can be found in the → **Catalogue Clamping Technology, chapter 16, page 152.**

WTX – Drill-Reamer 1/100

- ▲ Solid carbide high-performance drill-reaming tool
- ▲ Drilling and reaming in one operation
- ▲ 3 drilling edges
- ▲ 6 reaming edges
- ▲ High feeds
- ▲ Good surface quality
- ▲ For blind holes and through holes

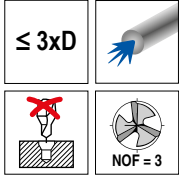

Feed
BR100

DPX14S

DRAGONSKIN

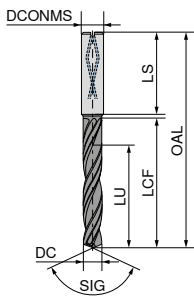

SIG 140°
Solid carbide

10 707 ...

DC $\pm 0,003$	DCONMS h_6	OAL	LCF	LU	LS	£	
mm	mm	mm	mm	mm	mm	T4	
3.97	6	66	24	17	36	166.00	03970
3.98	6	66	24	17	36	166.00	03980
3.99	6	66	24	17	36	166.00	03990
4.00	6	66	24	17	36	166.00	04000
4.01	6	66	24	17	36	166.00	04010
4.02	6	66	24	17	36	166.00	04020
4.97	6	66	28	20	36	166.00	04970
4.98	6	66	28	20	36	166.00	04980
4.99	6	66	28	20	36	166.00	04990
5.00	6	66	28	20	36	166.00	05000
5.01	6	66	28	20	36	166.00	05010
5.02	6	66	28	20	36	166.00	05020
5.97	6	66	28	20	36	166.00	05970
5.98	6	66	28	20	36	166.00	05980
5.99	6	66	28	20	36	166.00	05990
6.00	6	66	28	20	36	166.00	06000
6.01	6	66	28	20	36	166.00	06010
6.02	6	66	28	20	36	166.00	06020
7.97	8	79	41	29	36	166.00	07970
7.98	8	79	41	29	36	166.00	07980
7.99	8	79	41	29	36	166.00	07990
8.00	8	79	41	29	36	166.00	08000
8.01	8	79	41	29	36	166.00	08010
8.02	8	79	41	29	36	166.00	08020
9.97	10	89	47	35	40	188.92	09970
9.98	10	89	47	35	40	188.92	09980
9.99	10	89	47	35	40	188.92	09990
10.00	10	89	47	35	40	188.92	10000
10.01	10	89	47	35	40	188.92	10010
10.02	10	89	47	35	40	188.92	10020
11.97	12	102	55	40	45	258.88	11970
11.98	12	102	55	40	45	258.88	11980
11.99	12	102	55	40	45	258.88	11990
12.00	12	102	55	40	45	258.88	12000
12.01	12	102	55	40	45	258.88	12010
12.02	12	102	55	40	45	258.88	12020

P	●
M	●
K	●
N	●
S	●
H	●
O	●

		Tolerances					
		e.g. Ø 8 F7 = 8.02 mm					
Ø 4	3.97	U 7	X 7				
	3.98	N 10	N 11	R 7			
	3.99	M 8	N 7	N 8	N 9		
	4.00	J 7	J 8	JS 7	JS 8	JS 9	
	4.01	G 7	H 8				
	4.02	F 8	H 9				
Ø 5	4.97	U 7	X 7				
	4.98	N 10	N 11	R 7			
	4.99	M 8	N 7	N 8	N 9		
	5.00	J 7	J 8	JS 7	JS 8	JS 9	
	5.01	G 7	H 8				
	5.02	F 8	H 9				
Ø 6	5.97	U 7	X 7				
	5.98	N 10	N 11	R 7			
	5.99	M 8	N 7	N 8	N 9		
	6.00	J 7	J 8	JS 7	JS 8	JS 9	
	6.01	G 7	H 8				
	6.02	F 8	H 9				
Ø 8	7.97	S 7	U 7				
	7.98	N 8	N 10	N 11	P 7	R 7	
	7.99	K 8	M 6	M 7	M 8	N 9	
	8.00	J 7	J 8	JS 7	JS 8	JS 9	
	8.01	G 7	H 8				
	8.02	F 7	F 8	H 9			
Ø 10	9.97	S 7	U 7				
	9.98	N 8	N 10	N 11	P 7	R 7	
	9.99	K 8	M 6	M 7	M 8	N 9	
	10.00	J 7	J 8	JS 7	JS 8	JS 9	
	10.01	G 7	H 8				
	10.02	F 7	F 8	H 9			
Ø 12	11.97	N 11	R 7	S 7			
	11.98	N 8	N 9	N 10	P 7		
	11.99	K 8	M 6	M 7	M 8	N 7	
	12.00	J 7	J 8	JS 7	JS 8		
	12.01	G 6	H 7	H 8	JS 9		
	12.02	F 7					

Tolerance classes written in standard print are not optimally positioned in the tolerance field.

WTX – Drill-Reamer 1/100

- ▲ Solid carbide high-performance drill-reaming tool
- ▲ Drilling and reaming in one operation
- ▲ 3 drilling edges
- ▲ 6 reaming edges
- ▲ High feeds
- ▲ Good surface quality
- ▲ For blind holes and through holes

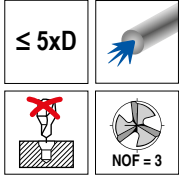

Feed
BR100

DPX14S

DRAGONSKIN

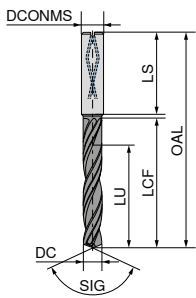

SIG 140°
Solid carbide

10 713 ...

DC $\pm 0,003$	DCONMS h_6	OAL	LCF	LU	LS	£	
mm	mm	mm	mm	mm	mm	T4	
3.97	6	74	36	29	36	207.02	03970
3.98	6	74	36	29	36	207.02	03980
3.99	6	74	36	29	36	207.02	03990
4.00	6	74	36	29	36	207.02	04000
4.01	6	74	36	29	36	207.02	04010
4.02	6	74	36	29	36	207.02	04020
4.97	6	82	44	35	36	207.02	04970
4.98	6	82	44	35	36	207.02	04980
4.99	6	82	44	35	36	207.02	04990
5.00	6	82	44	35	36	207.02	05000
5.01	6	82	44	35	36	207.02	05010
5.02	6	82	44	35	36	207.02	05020
5.97	6	82	44	35	36	207.02	05970
5.98	6	82	44	35	36	207.02	05980
5.99	6	82	44	35	36	207.02	05990
6.00	6	82	44	35	36	207.02	06000
6.01	6	82	44	35	36	207.02	06010
6.02	6	82	44	35	36	207.02	06020
7.97	8	91	53	43	36	207.02	07970
7.98	8	91	53	43	36	207.02	07980
7.99	8	91	53	43	36	207.02	07990
8.00	8	91	53	43	36	207.02	08000
8.01	8	91	53	43	36	207.02	08010
8.02	8	91	53	43	36	207.02	08020
9.97	10	103	61	49	40	283.73	09970
9.98	10	103	61	49	40	283.73	09980
9.99	10	103	61	49	40	283.73	09990
10.00	10	103	61	49	40	283.73	10000
10.01	10	103	61	49	40	283.73	10010
10.02	10	103	61	49	40	283.73	10020
11.97	12	118	71	56	45	398.83	11970
11.98	12	118	71	56	45	398.83	11980
11.99	12	118	71	56	45	398.83	11990
12.00	12	118	71	56	45	398.83	12000
12.01	12	118	71	56	45	398.83	12010
12.02	12	118	71	56	45	398.83	12020

P	●
M	●
K	●
N	●
S	●
H	●
O	●

		Tolerances					
		e.g. Ø 8 F7 = 8.02 mm					
Ø 4	3.97	U 7	X 7				
	3.98	N 10	N 11	R 7			
	3.99	M 8	N 7	N 8	N 9		
	4.00	J 7	J 8	JS 7	JS 8	JS 9	
	4.01	G 7	H 8				
Ø 5	4.02	F 8	H 9				
	4.97	U 7	X 7				
	4.98	N 10	N 11	R 7			
	4.99	M 8	N 7	N 8	N 9		
	5.00	J 7	J 8	JS 7	JS 8	JS 9	
Ø 6	5.01	G 7	H 8				
	5.02	F 8	H 9				
	5.97	U 7	X 7				
	5.98	N 10	N 11	R 7			
	5.99	M 8	N 7	N 8	N 9		
Ø 8	6.00	J 7	J 8	JS 7	JS 8	JS 9	
	6.01	G 7	H 8				
	6.02	F 8	H 9				
	7.97	S 7	U 7				
	7.98	N 8	N 10	N 11	P 7	R 7	
Ø 10	7.99	K 8	M 6	M 7	M 8	N 9	
	8.00	J 7	J 8	JS 7	JS 8	JS 9	
	8.01	G 7	H 8				
	8.02	F 7	F 8	H 9			
	9.97	S 7	U 7				
Ø 12	9.98	N 8	N 10	N 11	P 7	R 7	
	9.99	K 8	M 6	M 7	M 8	N 9	
	10.00	J 7	J 8	JS 7	JS 8	JS 9	
	10.01	G 7	H 8				
	10.02	F 7	F 8	H 9			
Ø 12	11.97	N 11	R 7	S 7			
	11.98	N 8	N 9	N 10	P 7		
	11.99	K 8	M 6	M 7	M 8	N 7	
	12.00	J 7	J 8	JS 7	JS 8		
	12.01	G 6	H 7	H 8	JS 9		
12.02	F 7						

Tolerance classes written in standard print are not optimally positioned in the tolerance field.

WTX – Drill-Reamer H7

- ▲ Solid carbide high-performance drill-reaming tool
- ▲ Drilling and reaming to tolerance H7 in one operation
- ▲ 3 drilling edges
- ▲ 6 reaming edges
- ▲ High feeds
- ▲ Good surface quality
- ▲ For blind holes and through holes
- ▲ Optimum roundness – tolerance H7

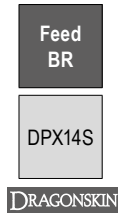
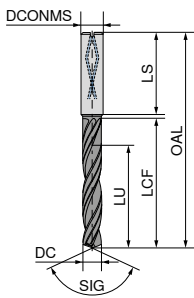
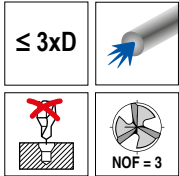

SIG 140°
Solid carbide

10 711 ...

DC _{H7} mm	DCONMS _{h6} mm	OAL mm	LCF mm	LU mm	LS mm	£ T4
4	6	66	24	17	36	166.00 04000
5	6	66	28	20	36	166.00 05000
6	6	66	28	20	36	166.00 06000
8	8	79	41	29	36	166.00 08000
10	10	89	47	35	40	188.92 10000
12	12	102	55	40	45	258.88 12000
14	14	107	60	43	45	346.22 14000
16	16	115	65	45	48	481.34 16000

P	●
M	●
K	●
N	
S	
H	
O	

→ v_c Page 140

Special dimensions available upon request

WTX – Drill-Reamer H7

- ▲ Solid carbide high-performance drill-reaming tool
- ▲ Drilling and reaming to tolerance H7 in one operation
- ▲ 3 drilling edges
- ▲ 6 reaming edges
- ▲ High feeds
- ▲ Good surface quality
- ▲ For blind holes and through holes
- ▲ Optimum roundness – tolerance H7

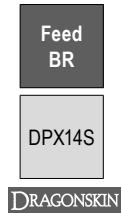
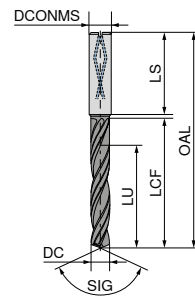
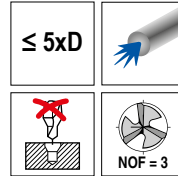

SIG 140°
Solid carbide

10 719 ...

DC _{H7} mm	DCONMS _{h6} mm	OAL mm	LCF mm	LU mm	LS mm	£ T4
4	6	74	36	29	36	207.02 04000
5	6	82	44	35	36	207.02 05000
6	6	82	44	35	36	207.02 06000
8	8	91	53	43	36	207.02 08000
10	10	103	61	49	40	283.73 10000
12	12	118	71	56	45	398.83 12000
14	14	124	77	60	45	541.06 14000
16	16	133	83	63	48	650.95 16000
18	18	143	93	71	48	781.61 18000
20	20	153	101	77	50	939.89 20000

P	●
M	●
K	●
N	
S	
H	
O	

→ v_c Page 141

Special dimensions available upon request

WTX – Short 90° step drill

▲ for core hole plus countersink for thread cutting

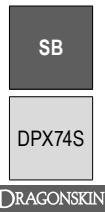
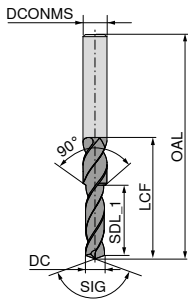
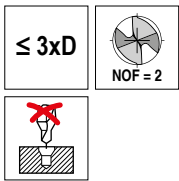

SIG 140°
Solid carbide

10 767 ...

For threads	DC _{m7} mm	DCONMS _{h6} mm	OAL mm	SDL_1 mm	LCF mm	£ T4	
M3	2.5	6	62	8.8	20	65.35	02500
M4	3.3	6	62	11.4	24	80.08	03300
M5	4.2	6	66	13.6	28	82.48	04200
M6	5.0	8	79	16.5	34	116.74	05000
M8	6.8	10	89	21.0	47	169.18	06800
M10	8.5	12	102	25.5	55	223.93	08500
M12	10.2	14	107	30.0	60	288.15	10200
M14	12.0	16	115	34.5	65	329.08	12000
M16	14.0	18	123	38.5	73	370.25	14000

P	●
M	●
K	●
N	○
S	○
H	○
O	○

→ v_c Page 135

WTX – Short 90° step drill

▲ for core hole plus countersink for thread forming

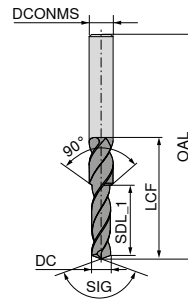
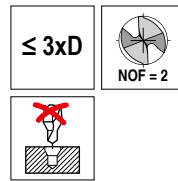

SIG 140°
Solid carbide

10 772 ...

For threads	DC _{m7} mm	DCONMS _{h6} mm	OAL mm	SDL_1 mm	LCF mm	£ T4	
M3	2.80	6	62	8.8	20	65.35	02800
M4	3.70	6	62	11.4	24	80.08	03700
M5	4.65	6	66	13.6	28	82.48	04650
M6	5.55	8	79	16.5	34	116.74	05550
M8	7.45	10	89	21.0	47	169.18	07450
M10	9.30	12	102	25.5	55	223.93	09300
M12	11.20	14	107	30.0	60	288.15	11200
M14	13.00	16	115	34.5	65	329.08	13000
M16	15.00	18	123	38.5	73	370.25	15000

P	●
M	●
K	●
N	○
S	○
H	○
O	○

→ v_c Page 135

WTX – Short 90° step drill

▲ for core hole plus countersink for thread cutting

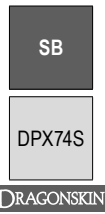
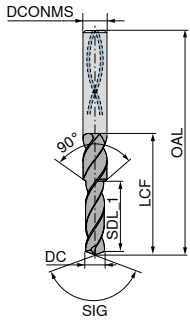
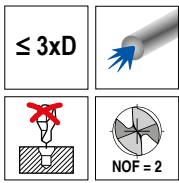

SIG 140°
Solid carbide

10 783 ...

For threads	DC _{m7} mm	DCONMS _{h6} mm	OAL mm	SDL_1 mm	LCF mm	£ T4	
M4	3.3	6	62	11.4	24	84.22	03300
M5	4.2	6	66	13.6	28	88.53	04200
M6	5.0	8	79	16.5	34	112.30	05000
M8	6.8	10	89	21.0	47	182.26	06800
M10	8.5	12	102	25.5	55	224.90	08500
M12	10.2	14	107	30.0	60	315.43	10200
M14	12.0	16	115	34.5	65	383.06	12000
M16	14.0	18	123	38.5	73	396.04	14000

P	●
M	
K	●
N	
S	
H	○
O	

→ v_c Page 135

WTX – Short 90° step drill

▲ for core hole plus countersink for thread forming

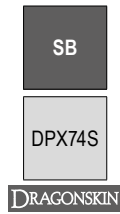
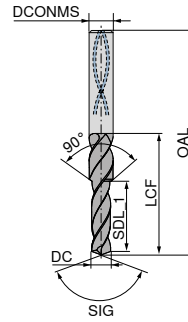
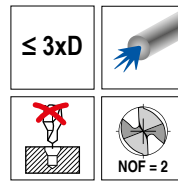

SIG 140°
Solid carbide

10 788 ...

For threads	DC _{m7} mm	DCONMS _{h6} mm	OAL mm	SDL_1 mm	LCF mm	£ T4	
M4	3.70	6	62	11.4	24	84.22	03700
M5	4.65	6	66	13.6	28	88.53	04650
M6	5.55	8	79	16.5	34	112.30	05550
M8	7.45	10	89	21.0	47	182.26	07450
M10	9.30	12	102	25.5	55	224.90	09300
M12	11.20	14	107	30.0	60	315.43	11200
M14	13.00	16	115	34.5	65	383.06	13000
M16	15.00	18	123	38.5	73	396.04	15000

P	●
M	
K	●
N	
S	
H	○
O	

→ v_c Page 135

NC Spot Drill, factory standard

▲ spiral flute

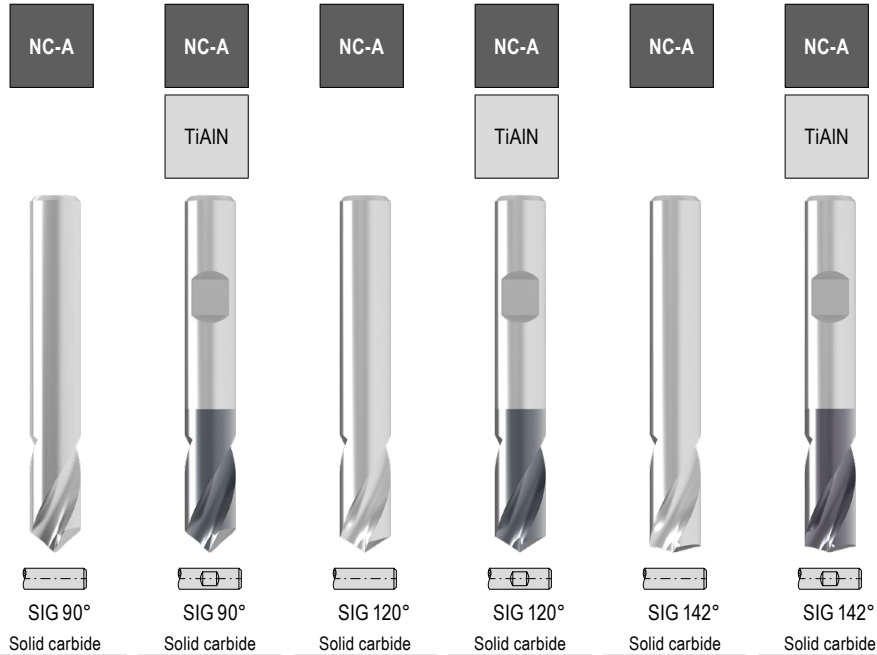
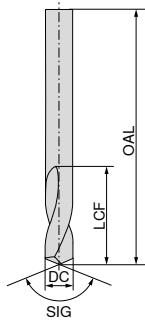

DC _{js8} mm	OAL mm	LCF mm	10 702 ...		10 716 ...		10 703 ...		10 717 ...		10 704 ...		10 718 ...	
			£ T3	002	£ T3	002	£ T3	002	£ T3	002	£ T3	002	£ T3	002
2	32	6	27.94	002	27.47	002 ¹⁾	27.94	002	27.47	002 ¹⁾	27.94	002	27.47	002 ¹⁾
3	32	8	27.94	003	27.47	003 ¹⁾	27.94	003	27.47	003 ¹⁾	27.94	003	27.47	003 ¹⁾
4	40	10	21.91	004	28.97	004 ¹⁾	21.91	004	28.97	004 ¹⁾	21.91	004	28.97	004 ¹⁾
5	50	13	25.17	005	32.03	005 ¹⁾	25.17	005	32.03	005 ¹⁾	25.17	005	32.03	005 ¹⁾
6	50	13	28.08	006	35.07	006	28.08	006	35.07	006	28.08	006	35.07	006
8	60	23	43.15	008	48.81	008	43.15	008	48.81	008	43.15	008	48.81	008
10	70	24	60.51	010	64.07	010	60.51	010	64.07	010	60.51	010	64.07	010
12	70	24	87.28	012	83.89	012	87.28	012	83.89	012	87.28	012	83.89	012
14	75	26	100.36	014	123.54	014	100.36	014	123.54	014	100.36	014	123.54	014
16	75	29	146.48	016	143.39	016	146.48	016	143.39	016	146.48	016	143.39	016
18	100	35	284.11	018	257.78	018	284.11	018	257.78	018	284.11	018	257.78	018
20	100	35	238.51	020	271.49	020	238.51	020	271.49	020	238.51	020	271.49	020
P				●		●		●		●		●		●
M														
K				●		●		●		●		●		●
N				●		●		●		●		●		●
S														
H					○			○		○		○		○
O														

1) DIN 6535 HA Shank

NC Spot Drill, factory standard, long

▲ spiral flutes

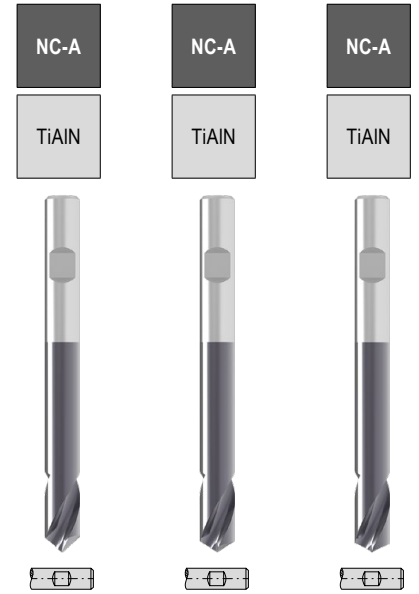
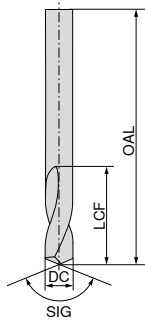

SIG 90° Solid carbide SIG 120° Solid carbide SIG 142° Solid carbide

DC _{js8} mm	OAL mm	LCF mm
3	66	8
4	74	10
6	82	13
8	91	23
10	103	24
12	118	24
16	133	29

10 724 ...		10 726 ...		10 727 ...	
£		£		£	
T3		T3		T3	
28.97	003 ¹⁾	28.97	003 ¹⁾	28.97	003 ¹⁾
33.55	004 ¹⁾	33.55	004 ¹⁾	33.55	004 ¹⁾
42.71	006	42.71	006	42.71	006
62.54	008	62.54	008	62.54	008
86.94	010	86.94	010	86.94	010
131.18	012	131.18	012	131.18	012
245.57	016	245.57	016	245.57	016

P	●	●	●
M	●	●	●
K	●	●	●
N	●	●	●
S	●	●	●
H	○	○	○
O			

1) DIN 6535 HA Shank

Centre drills, DIN 333, form A

- ▲ Spiral-fluted
- ▲ Up to and including diameter DC of 0.8 mm suitable for use on one side only

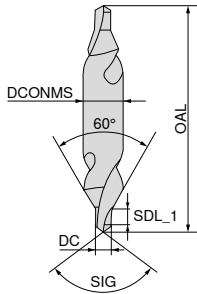

SIG 120°
Solid carbide

10 708 ...

DC _{k13} mm	DCONMS _{h6} mm	OAL mm	SDL_1 mm	£ T3	
0.50	3.15	20.0	0.76	47.33	050 ¹⁾
0.80	3.15	20.0	1.07	47.33	080 ¹⁾
1.00	3.15	31.5	1.31	46.14	100
1.25	3.15	31.5	1.54	46.14	125
1.60	4.00	35.5	1.94	48.89	160
2.00	5.00	40.0	2.32	51.62	200
2.50	6.30	45.0	2.88	58.17	250
3.15	8.00	50.0	3.49	67.90	315
4.00	10.00	56.0	4.45	81.75	400
5.00	12.50	63.0	5.46	121.58	500
6.30	16.00	71.0	6.78	184.85	630

P	●
M	
K	●
N	●
S	
H	
O	

1) Single ended

WTX – Drilling Head for Exchangeable drills

- ▲ extra long head type
- ▲ three-edged

Scope of supply:

Drill head incl. differential screw

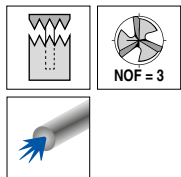

Change Feed UNI
Ti750

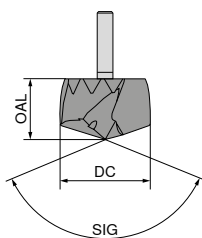

SIG 140°
Solid carbide

DC _{m7} mm	OAL mm	£ W2	10 925 ...
14.0	13.5	129.81	140
14.1	13.5	129.81	141
14.2	13.5	129.81	142
14.3	13.5	129.81	143
14.4	13.5	129.81	144
14.5	14.0	129.81	145
14.6	14.0	129.81	146
14.7	14.0	129.81	147
14.8	14.0	129.81	148
14.9	14.0	129.81	149
15.0	14.4	129.81	150
15.1	14.4	129.81	151
15.2	14.4	129.81	152
15.3	14.4	129.81	153
15.4	14.4	129.81	154
15.5	15.4	145.38	155
15.6	15.4	145.38	156
15.7	15.4	145.38	157
15.8	15.4	145.38	158
15.9	15.4	145.38	159
16.0	15.4	145.38	160
16.1	15.4	145.38	161
16.2	15.4	145.38	162
16.3	15.4	145.38	163
16.4	15.4	145.38	164
16.5	16.3	145.38	165
16.6	16.3	145.38	166
16.7	16.3	145.38	167
16.8	16.3	145.38	168
16.9	16.3	145.38	169
17.0	16.3	145.38	170
17.1	16.3	145.38	171
17.2	16.3	145.38	172
17.3	16.3	145.38	173
17.4	16.3	145.38	174
17.5	17.2	165.02	175
17.6	17.2	165.02	176
17.7	17.2	165.02	177
17.8	17.2	165.02	178
17.9	17.2	165.02	179
18.0	17.2	165.02	180
18.1	17.2	165.02	181
18.2	17.2	165.02	182
18.3	17.2	165.02	183
18.4	17.2	165.02	184
18.5	18.2	165.02	185
18.6	18.2	165.02	186
18.7	18.2	165.02	187
18.8	18.2	165.02	188
18.9	18.2	165.02	189

DC _{m7} mm	OAL mm	£ W2	10 925 ...
19.0	18.2	165.02	190
19.1	18.2	165.02	191
19.2	18.2	165.02	192
19.3	18.2	165.02	193
19.4	18.2	165.02	194
19.5	19.1	189.35	195
19.6	19.1	189.35	196
19.7	19.1	189.35	197
19.8	19.1	189.35	198
19.9	19.1	189.35	199
20.0	19.1	189.35	200
20.1	19.1	189.35	201
20.2	19.1	189.35	202
20.3	19.1	189.35	203
20.4	19.1	189.35	204
20.5	20.0	189.35	205
20.6	20.0	189.35	206
20.7	20.0	189.35	207
20.8	20.0	189.35	208
20.9	20.0	189.35	209
21.0	20.0	189.35	210
21.1	20.0	189.35	211
21.2	20.0	189.35	212
21.3	20.0	189.35	213
21.4	20.0	189.35	214
21.5	21.0	189.35	215
21.6	21.0	189.35	216
21.7	21.0	189.35	217
21.8	21.0	189.35	218
21.9	21.0	189.35	219
22.0	21.0	189.35	220
22.1	21.0	189.35	221
22.2	21.0	189.35	222
22.3	21.0	189.35	223
22.4	21.0	189.35	224
22.5	21.9	210.64	225
22.6	21.9	210.64	226
22.7	21.9	210.64	227
22.8	21.9	210.64	228
22.9	21.9	210.64	229
23.0	21.9	210.64	230
23.1	21.9	210.64	231
23.2	21.9	210.64	232
23.3	21.9	210.64	233
23.4	21.9	210.64	234
23.5	22.8	210.64	235
23.6	22.8	210.64	236
23.7	22.8	210.64	237
23.8	22.8	210.64	238
23.9	22.8	210.64	239
24.0	22.8	210.64	240
24.1	22.8	210.64	241
24.2	22.8	210.64	242
24.3	22.8	210.64	243
24.4	22.8	210.64	244
24.5	23.8	238.76	245
24.6	23.8	238.76	246
24.7	23.8	238.76	247
24.8	23.8	238.76	248
24.9	23.8	238.76	249
25.0	23.8	238.76	250

P	●
M	
K	●
N	
S	
H	
O	

→ v_c Page 156

→ Application recommendation on page 162

When changing the head, please observe the specified tightening torque.

WTX – Drilling Head for Exchangeable drills

- ▲ extra long head type
- ▲ three-edged

Scope of supply:

Drill head incl. differential screw

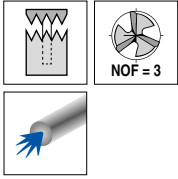

Change Feed UNI
Ti750

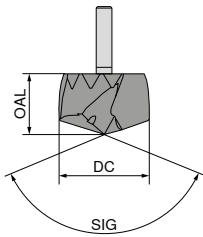

SIG 140°
Solid carbide

DC _{m7} mm	OAL mm	£ W2	10 925 ...
25.1	23.8	238.76	251
25.2	23.8	238.76	252
25.3	23.8	238.76	253
25.4	23.8	238.76	254
25.5	24.7	238.76	255
25.6	24.7	238.76	256
25.7	24.7	238.76	257
25.8	24.7	238.76	258
25.9	24.7	238.76	259
26.0	24.7	238.76	260
26.1	24.7	238.76	261
26.2	24.7	238.76	262
26.3	24.7	238.76	263
26.4	24.7	238.76	264
26.5	25.6	257.56	265
26.6	25.6	257.56	266
26.7	25.6	257.56	267
26.8	25.6	257.56	268
26.9	25.6	257.56	269
27.0	25.6	257.56	270
27.1	25.6	257.56	271
27.2	25.6	257.56	272
27.3	25.6	257.56	273
27.4	25.6	257.56	274
27.5	26.6	257.56	275
27.6	26.6	257.56	276
27.7	26.6	257.56	277
27.8	26.6	257.56	278
27.9	26.6	257.56	279
28.0	26.6	257.56	280
28.1	26.6	257.56	281
28.2	26.6	257.56	282
28.3	26.6	257.56	283
28.4	26.6	257.56	284
28.5	27.5	284.10	285
28.6	27.5	284.10	286
28.7	27.5	284.10	287
28.8	27.5	284.10	288
28.9	27.5	284.10	289
29.0	27.5	284.10	290
29.1	27.5	284.10	291
29.2	27.5	284.10	292
29.3	27.5	284.10	293
29.4	27.5	284.10	294
29.5	28.4	284.10	295
29.6	28.4	284.10	296
29.7	28.4	284.10	297
29.8	28.4	284.10	298
29.9	28.4	284.10	299
30.0	28.4	284.10	300

10 925 ...

DC _{m7} mm	OAL mm	£ W2	10 925 ...
30.1	28.4	284.10	301
30.2	28.4	284.10	302
30.3	28.4	284.10	303
30.4	28.4	284.10	304
30.5	29.3	310.13	305
30.6	29.3	310.13	306
30.7	29.3	310.13	307
30.8	29.3	310.13	308
30.9	29.3	310.13	309
31.0	29.3	310.13	310
31.1	29.3	310.13	311
31.2	29.3	310.13	312
31.3	29.3	310.13	313
31.4	29.3	310.13	314
31.5	30.3	310.13	315
31.6	30.3	310.13	316
31.7	30.3	310.13	317
31.8	30.3	310.13	318
31.9	30.3	310.13	319
32.0	30.3	310.13	320

P	•
M	
K	•
N	
S	
H	
O	

→ v_c Page 156

→ Application recommendation on page 162



When changing the head, please observe the specified tightening torque.

WTX – Holder for Exchangeable drills

Scope of supply:

Holder incl. blade holder and interchangeable blade

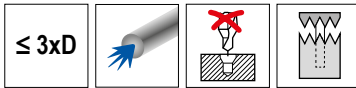

Change Feed

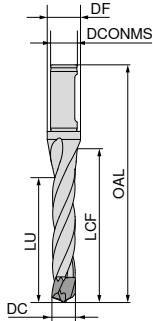

10 914 ...

DC mm	DCONMS _{h6} mm	OAL mm	LCF mm	LU mm	DF mm	torque moment Nm	£ W1	
14,00 - 14,49	16	120	72	48	20	0,7	338.88	140
14,50 - 14,99	16	122	74	49	20	0,7	338.88	145
15,00 - 15,49	16	124	76	51	25	0,7	338.88	150
15,50 - 16,49	20	131	81	54	25	0,7	350.15	155
16,50 - 17,49	20	135	85	58	25	0,7	350.15	165
17,50 - 18,49	20	140	90	61	25	1,3	350.15	175
18,50 - 19,49	25	150	94	64	31	1,3	412.47	185
19,50 - 20,49	25	155	99	68	31	2,0	416.20	195
20,50 - 21,49	25	159	103	71	31	2,0	455.72	205
21,50 - 22,49	25	164	108	74	31	2,0	455.72	215
22,50 - 23,49	25	168	112	78	31	2,0	499.40	225
23,50 - 24,49	25	173	117	81	31	2,0	499.40	235
24,50 - 25,49	32	182	122	84	38	3,1	562.01	245
25,50 - 26,49	32	186	126	87	38	3,1	562.01	255
26,50 - 27,49	32	191	131	91	38	3,1	562.01	265
27,50 - 28,49	32	195	135	94	38	3,1	562.01	275
28,50 - 29,49	32	200	140	97	38	5,6	647.69	285
29,50 - 30,49	32	204	144	101	38	5,6	647.69	295
30,50 - 31,49	32	209	149	104	38	5,6	708.52	305
31,50 - 32,49	32	213	153	107	38	5,6	708.52	315

WTX – Holder for Exchangeable drills

Scope of supply:

Holder incl. blade holder and interchangeable blade

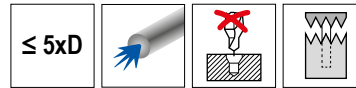

Change Feed

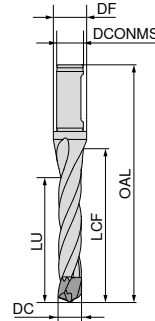

10 916 ...

DC mm	DCONMS _{h6} mm	OAL mm	LCF mm	LU mm	DF mm	torque moment Nm	£ W1	
14,00 - 14,49	16	149	101	77	20	0,7	374.31	140
14,50 - 14,99	16	152	104	79	20	0,7	374.31	145
15,00 - 15,49	16	155	107	82	25	0,7	374.31	150
15,50 - 16,49	20	164	114	87	25	0,7	405.34	155
16,50 - 17,49	20	170	120	93	25	0,7	405.34	165
17,50 - 18,49	20	177	127	98	25	1,3	405.34	175
18,50 - 19,49	25	189	133	103	31	1,3	463.70	185
19,50 - 20,49	25	196	140	109	31	2,0	467.28	195
20,50 - 21,49	25	202	146	114	31	2,0	509.96	205
21,50 - 22,49	25	209	153	119	31	2,0	509.96	215
22,50 - 23,49	25	215	159	124	31	2,0	549.25	225
23,50 - 24,49	25	222	166	130	31	2,0	549.25	235
24,50 - 25,49	32	233	173	135	38	3,1	610.61	245
25,50 - 26,49	32	239	179	140	38	3,1	610.61	255
26,50 - 27,49	32	246	186	146	38	3,1	610.61	265
27,50 - 28,49	32	252	192	151	38	3,1	610.61	275
28,50 - 29,49	32	259	199	156	38	5,6	694.78	285
29,50 - 30,49	32	265	205	162	38	5,6	694.78	295
30,50 - 31,49	32	272	212	167	38	5,6	754.52	305
31,50 - 32,49	32	278	218	172	38	5,6	754.52	315

Spare parts

DC	80 022 ...		80 020 ...		80 023 ...		10 950 ...	
	£ W1		£ Y7		£ W1		£ W2	
14,00 - 14,49	26.02	007	42.57	025	434.54	012	8.52	064
14,50 - 14,99	26.02	007	42.57	025	434.54	012	8.52	064
15,00 - 15,49	26.02	007	42.57	025	434.54	012	8.52	064
15,50 - 16,49	26.02	007	42.57	025	434.54	012	8.52	064
16,50 - 17,49	26.02	007	42.57	025	434.54	012	8.52	064
17,50 - 18,49	26.02	008	42.57	025	465.10	060	8.52	065
18,50 - 19,49	26.02	008	42.57	025	465.10	060	8.52	065
19,50 - 20,49	30.27	010	42.57	025	465.10	060	8.52	066
20,50 - 21,49	30.27	010	42.57	025	465.10	060	8.52	066
21,50 - 22,49	30.27	010	42.57	025	465.10	060	8.52	066
22,50 - 23,49	30.27	010	42.57	025	465.10	060	8.52	066
23,50 - 24,49	30.27	010	42.57	025	465.10	060	8.52	066
24,50 - 25,49	48.90	015	42.57	025	465.10	060	8.52	067
25,50 - 26,49	48.90	015	42.57	025	465.10	060	8.52	067
26,50 - 27,49	48.90	015	42.57	025	465.10	060	8.52	067
27,50 - 28,49	48.90	015	42.57	025	465.10	060	8.52	067
28,50 - 29,49	48.90	015	42.57	025	465.10	060	8.52	068
29,50 - 30,49	48.90	015	42.57	025	465.10	060	8.52	068
30,50 - 31,49	48.90	015	42.57	025	465.10	060	8.52	068
31,50 - 32,49	48.90	015	42.57	025	465.10	060	8.52	068

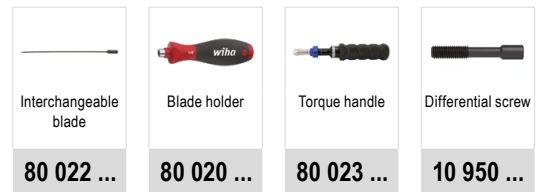

WTX – Holder for Exchangeable drills

Scope of supply:

Holder incl. blade holder and interchangeable blade

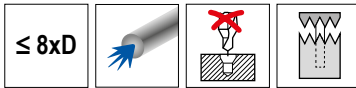

Change Feed

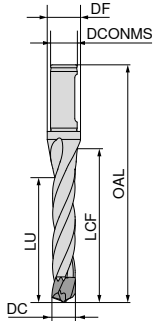

10 917 ...

DC mm	DCONMS _{h6} mm	OAL mm	LCF mm	LU mm	DF mm	torque moment Nm	£ W1	
14,00 - 14,49	16	192	144	120	20	0,7	489.80	14000
14,50 - 14,99	16	197	149	124	20	0,7	489.80	14500
15,00 - 15,49	16	202	154	129	25	0,7	489.80	15000
15,50 - 16,49	20	213	163	137	25	0,7	526.17	15500
16,50 - 17,49	20	223	173	145	25	0,7	526.17	16500
17,50 - 18,49	20	232	182	153	25	1,3	526.17	17500
18,50 - 19,49	25	248	192	162	31	1,3	592.43	18500
19,50 - 20,49	25	257	201	170	31	2,0	600.56	19500
20,50 - 21,49	25	267	211	178	31	2,0	640.96	20500
21,50 - 22,49	25	276	220	187	31	2,0	640.96	21500
22,50 - 23,49	25	286	230	195	31	2,0	710.93	22500
23,50 - 24,49	25	295	239	203	31	2,0	710.93	23500
24,50 - 25,49	32	309	249	212	38	3,1	767.32	24500
25,50 - 26,49	32	319	259	220	38	3,1	767.32	25500
26,50 - 27,49	32	328	268	228	38	3,1	767.32	26500
27,50 - 28,49	32	338	278	236	38	3,1	767.32	27500
28,50 - 29,49	32	342	282	245	38	5,6	880.65	28500
29,50 - 30,49	32	352	292	253	38	5,6	880.65	29500
30,50 - 31,49	32	361	301	261	38	5,6	971.29	30500
31,50 - 32,49	32	371	311	270	38	5,6	971.29	31500

Spare parts
DC

	80 022 ...		80 020 ...		80 023 ...		10 950 ...	
	£ W1		£ Y7		£ W1		£ W2	
14,00 - 14,49	26.02	007	42.57	025	434.54	012	8.52	064
14,50 - 14,99	26.02	007	42.57	025	434.54	012	8.52	064
15,00 - 15,49	26.02	007	42.57	025	434.54	012	8.52	064
15,50 - 16,49	26.02	007	42.57	025	434.54	012	8.52	064
16,50 - 17,49	26.02	007	42.57	025	434.54	012	8.52	064
17,50 - 18,49	26.02	008	42.57	025	465.10	060	8.52	065
18,50 - 19,49	26.02	008	42.57	025	465.10	060	8.52	065
19,50 - 20,49	30.27	010	42.57	025	465.10	060	8.52	066
20,50 - 21,49	30.27	010	42.57	025	465.10	060	8.52	066
21,50 - 22,49	30.27	010	42.57	025	465.10	060	8.52	066
22,50 - 23,49	30.27	010	42.57	025	465.10	060	8.52	066
23,50 - 24,49	30.27	010	42.57	025	465.10	060	8.52	066
24,50 - 25,49	48.90	015	42.57	025	465.10	060	8.52	067
25,50 - 26,49	48.90	015	42.57	025	465.10	060	8.52	067
26,50 - 27,49	48.90	015	42.57	025	465.10	060	8.52	067
27,50 - 28,49	48.90	015	42.57	025	465.10	060	8.52	067
28,50 - 29,49	48.90	015	42.57	025	465.10	060	8.52	068
29,50 - 30,49	48.90	015	42.57	025	465.10	060	8.52	068
30,50 - 31,49	48.90	015	42.57	025	465.10	060	8.52	068
31,50 - 32,49	48.90	015	42.57	025	465.10	060	8.52	068

Interchangeable blade	Blade holder	Torque handle	Differential screw
80 022 ...	80 020 ...	80 023 ...	10 950 ...
£ W1	£ Y7	£ W1	£ W2

WTX – Drilling Head for Exchangeable drills

▲ extra long head type

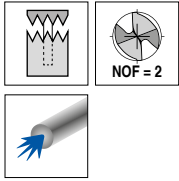

Change UNI	Change P	Change VA	Change GG	Change AL
DPX74S	Ti750	Ti700	TiSi	TiB

DRAGONSKIN

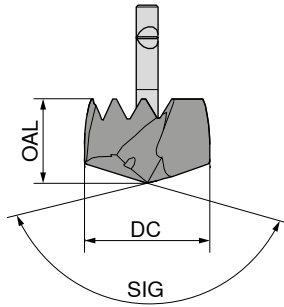

DC _{h7/m7} mm	OAL mm	10 919 ... Solid carbide		10 923 ... Solid carbide		10 921 ... Solid carbide		10 924 ... Solid carbide		10 922 ... Solid carbide	
		£	W2	£	W2	£	W2	£	W2	£	W2
12.0	10.7	153.11	12000	153.11	120	153.11	120	153.11	120	153.11	120
12.1	10.7	153.11	12100	153.11	121	153.11	121	153.11	121	153.11	121
12.2	10.7	153.11	12200	153.11	122	153.11	122	153.11	122	153.11	122
12.3	10.7	153.11	12300	153.11	123	153.11	123	153.11	123	153.11	123
12.4	10.7	153.11	12400	153.11	124	153.11	124	153.11	124	153.11	124
12.5	10.7	153.11	12500	153.11	125	153.11	125	153.11	125	153.11	125
12.6	10.7	153.11	12600	153.11	126	153.11	126	153.11	126	153.11	126
12.7	10.7	153.11	12700	153.11	127	153.11	127	153.11	127	153.11	127
12.8	10.7	153.11	12800	153.11	128	153.11	128	153.11	128	153.11	128
12.9	10.7	153.11	12900	153.11	129	153.11	129	153.11	129	153.11	129
13.0	10.7	153.11	13000	153.11	130	153.11	130	153.11	130	153.11	130
13.1	10.7	153.11	13100	153.11	131	153.11	131	153.11	131	153.11	131
13.2	10.7	153.11	13200	153.11	132	153.11	132	153.11	132	153.11	132
13.3	10.7	153.11	13300	153.11	133	153.11	133	153.11	133	153.11	133
13.4	10.7	153.11	13400	153.11	134	153.11	134	153.11	134	153.11	134
13.5	11.3	153.11	13500	153.11	135	153.11	135	153.11	135	153.11	135
13.6	11.3	153.11	13600	153.11	136	153.11	136	153.11	136	153.11	136
13.7	11.3	153.11	13700	153.11	137	153.11	137	153.11	137	153.11	137
13.8	11.3	153.11	13800	153.11	138	153.11	138	153.11	138	153.11	138
13.9	11.3	153.11	13900	153.11	139	153.11	139	153.11	139	153.11	139
14.0	11.3	153.11	14000	153.11	140	153.11	140	153.11	140	153.11	140
14.1	11.3	153.11	14100	153.11	141	153.11	141	153.11	141	153.11	141
14.2	11.3	153.11	14200	153.11	142	153.11	142	153.11	142	153.11	142
14.3	11.3	153.11	14300	153.11	143	153.11	143	153.11	143	153.11	143
14.4	11.3	153.11	14400	153.11	144	153.11	144	153.11	144	153.11	144
14.5	11.3	153.11	14500	153.11	145	153.11	145	153.11	145	153.11	145
14.6	11.3	153.11	14600	153.11	146	153.11	146	153.11	146	153.11	146
14.7	11.3	153.11	14700	153.11	147	153.11	147	153.11	147	153.11	147
14.8	11.3	153.11	14800	153.11	148	153.11	148	153.11	148	153.11	148
14.9	11.3	153.11	14900	153.11	149	153.11	149	153.11	149	153.11	149
15.0	11.3	153.11	15000	153.11	150	153.11	150	153.11	150	153.11	150
15.1	11.3	153.11	15100	153.11	151	153.11	151	153.11	151	153.11	151
15.2	11.3	153.11	15200	153.11	152	153.11	152	153.11	152	153.11	152
15.3	11.3	153.11	15300	153.11	153	153.11	153	153.11	153	153.11	153
15.4	11.3	153.11	15400	153.11	154	153.11	154	153.11	154	153.11	154
15.5	11.9	153.11	15500	153.11	155	153.11	155	153.11	155	153.11	155
15.6	11.9	153.11	15600	153.11	156	153.11	156	153.11	156	153.11	156
15.7	11.9	153.11	15700	153.11	157	153.11	157	153.11	157	153.11	157

P	●	●	○
M			●
K	●	●	●
N			●
S			●
H			
O			

→ v_c Page 152–155

→ Application recommendation on page 162

Ø DC_{m7} for Type UNI, P, GG und AL / Ø DC_{h7} for Type VA

WTX – Drilling Head for Exchangeable drills

▲ extra long head type

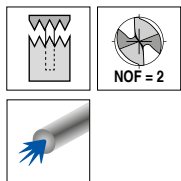

Change UNI	Change P	Change VA	Change GG	Change AL
DPX74S	Ti750	Ti700	TiSi	TiB

DRAGONSKIN

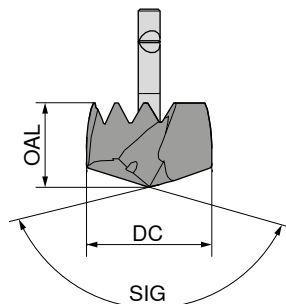

DC _{h7/m7} mm	OAL mm	10 919 ...		10 923 ...		10 921 ...		10 924 ...		10 922 ...	
		£	W2	£	W2	£	W2	£	W2	£	W2
15.8	11.9	153.11	15800	153.11	158	153.11	158	153.11	158	153.11	158
15.9	11.9	153.11	15900	153.11	159	153.11	159	153.11	159	153.11	159
16.0	11.9	153.11	16000	153.11	160	153.11	160	153.11	160	153.11	160
16.1	11.9	153.11	16100	153.11	161	153.11	161	153.11	161	153.11	161
16.2	11.9	153.11	16200	153.11	162	153.11	162	153.11	162	153.11	162
16.3	11.9	153.11	16300	153.11	163	153.11	163	153.11	163	153.11	163
16.4	11.9	153.11	16400	153.11	164	153.11	164	153.11	164	153.11	164
16.5	13.4	153.11	16500	153.11	165	153.11	165	153.11	165	153.11	165
16.6	13.4	153.11	16600	153.11	166	153.11	166	153.11	166	153.11	166
16.7	13.4	153.11	16700	153.11	167	153.11	167	153.11	167	153.11	167
16.8	13.4	153.11	16800	153.11	168	153.11	168	153.11	168	153.11	168
16.9	13.4	153.11	16900	153.11	169	153.11	169	153.11	169	153.11	169
17.0	13.4	153.11	17000	153.11	170	153.11	170	153.11	170	153.11	170
17.1	13.4	153.11	17100	153.11	171	153.11	171	153.11	171	153.11	171
17.2	13.4	153.11	17200	153.11	172	153.11	172	153.11	172	153.11	172
17.3	13.4	153.11	17300	153.11	173	153.11	173	153.11	173	153.11	173
17.4	13.4	153.11	17400	153.11	174	153.11	174	153.11	174	153.11	174
17.5	13.4	153.11	17500	153.11	175	153.11	175	153.11	175	153.11	175
17.6	13.4	153.11	17600	153.11	176	153.11	176	153.11	176	153.11	176
17.7	13.4	153.11	17700	153.11	177	153.11	177	153.11	177	153.11	177
17.8	13.4	153.11	17800	153.11	178	153.11	178	153.11	178	153.11	178
17.9	13.4	153.11	17900	153.11	179	153.11	179	153.11	179	153.11	179
18.0	13.4	153.11	18000	153.11	180	153.11	180	153.11	180	153.11	180
18.1	13.4	166.60	18100	166.60	181	166.60	181	166.60	181	166.60	181
18.2	13.4	166.60	18200	166.60	182	166.60	182	166.60	182	166.60	182
18.3	13.4	166.60	18300	166.60	183	166.60	183	166.60	183	166.60	183
18.4	13.4	166.60	18400	166.60	184	166.60	184	166.60	184	166.60	184
18.5	13.4	166.60	18500	166.60	185	166.60	185	166.60	185	166.60	185
18.6	13.4	166.60	18600	166.60	186	166.60	186	166.60	186	166.60	186
18.7	13.4	166.60	18700	166.60	187	166.60	187	166.60	187	166.60	187
18.8	13.4	166.60	18800	166.60	188	166.60	188	166.60	188	166.60	188
18.9	13.4	166.60	18900	166.60	189	166.60	189	166.60	189	166.60	189
19.0	13.4	166.60	19000	166.60	190	166.60	190	166.60	190	166.60	190
19.1	13.4	166.60	19100	166.60	191	166.60	191	166.60	191	166.60	191
19.2	13.4	166.60	19200	166.60	192	166.60	192	166.60	192	166.60	192
19.3	13.4	166.60	19300	166.60	193	166.60	193	166.60	193	166.60	193
19.4	13.4	166.60	19400	166.60	194	166.60	194	166.60	194	166.60	194
19.5	13.4	166.60	19500	166.60	195	166.60	195	166.60	195	166.60	195

P	●	●	○
M			●
K	●	●	●
N			●
S			●
H			
O			

→ v_c Page 152–155

→ Application recommendation on page 162

Ø DC_{m7} for Type UNI, P, GG und AL / Ø DC_{h7} for Type VA

WTX – Drilling Head for Exchangeable drills

▲ extra long head type

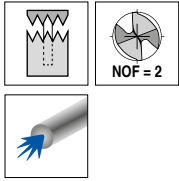

Change UNI	Change P	Change VA	Change GG	Change AL
DPX74S	Ti750	Ti700	TiSi	TiB

DRAGONSKIN

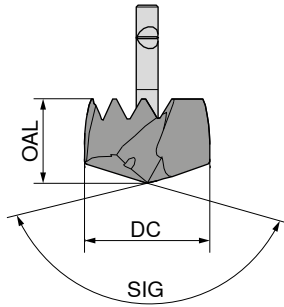

DC _{h7/m7} mm	OAL mm	SIG 140° Solid carbide		SIG 138° Solid carbide		SIG 138° Solid carbide		SIG 140° Solid carbide		SIG 140° Solid carbide	
		10 919 ...	10 923 ...	10 921 ...	10 924 ...	10 922 ...					
		£ W2	£ W2	£ W2	£ W2	£ W2	£ W2	£ W2	£ W2	£ W2	£ W2
19.6	13.4	166.60	19600	166.60	196	166.60	196	166.60	196	166.60	196
19.7	13.4	166.60	19700	166.60	197	166.60	197	166.60	197	166.60	197
19.8	13.4	166.60	19800	166.60	198	166.60	198	166.60	198	166.60	198
19.9	13.4	166.60	19900	166.60	199	166.60	199	166.60	199	166.60	199
20.0	13.4	166.60	20000	166.60	200	166.60	200	166.60	200	166.60	200
20.1	13.4	184.10	20100	184.10	201	184.10	201	184.10	201	138.82	201
20.2	13.4	184.10	20200	184.10	202	184.10	202	184.10	202	184.10	202
20.3	13.4	184.10	20300	184.10	203	184.10	203	184.10	203	184.10	203
20.4	13.4	184.10	20400	184.10	204	184.10	204	184.10	204	184.10	204
20.5	15.4	184.10	20500	184.10	205	184.10	205	184.10	205	184.10	205
20.6	15.4	184.10	20600	184.10	206	184.10	206	184.10	206	184.10	206
20.7	15.4	184.10	20700	184.10	207	184.10	207	184.10	207	184.10	207
20.8	15.4	184.10	20800	184.10	208	184.10	208	184.10	208	184.10	208
20.9	15.4	184.10	20900	184.10	209	184.10	209	184.10	209	184.10	209
21.0	15.4	184.10	21000	184.10	210	184.10	210	184.10	210	184.10	210
21.1	15.4	184.10	21100	184.10	211	184.10	211	184.10	211	184.10	211
21.2	15.4	184.10	21200	184.10	212	184.10	212	184.10	212	184.10	212
21.3	15.4	184.10	21300	184.10	213	184.10	213	184.10	213	184.10	213
21.4	15.4	184.10	21400	184.10	214	184.10	214	184.10	214	184.10	214
21.5	15.4	184.10	21500	184.10	215	184.10	215	184.10	215	184.10	215
21.6	15.4	184.10	21600	184.10	216	184.10	216	184.10	216	184.10	216
21.7	15.4	184.10	21700	184.10	217	184.10	217	184.10	217	184.10	217
21.8	15.4	184.10	21800	184.10	218	184.10	218	184.10	218	184.10	218
21.9	15.4	184.10	21900	184.10	219	184.10	219	184.10	219	184.10	219
22.0	15.4	184.10	22000	184.10	220	184.10	220	184.10	220	184.10	220
22.1	15.4	197.59	22100	197.59	221	197.59	221	197.59	221	197.59	221
22.2	15.4	197.59	22200	197.59	222	197.59	222	197.59	222	197.59	222
22.3	15.4	197.59	22300	197.59	223	197.59	223	197.59	223	197.59	223
22.4	15.4	197.59	22400	197.59	224	197.59	224	197.59	224	197.59	224
22.5	15.4	197.59	22500	197.59	225	197.59	225	197.59	225	197.59	225
22.6	15.4	197.59	22600	197.59	226	197.59	226	197.59	226	197.59	226
22.7	15.4	197.59	22700	197.59	227	197.59	227	197.59	227	197.59	227
22.8	15.4	197.59	22800	197.59	228	197.59	228	197.59	228	197.59	228
22.9	15.4	197.59	22900	197.59	229	197.59	229	197.59	229	197.59	229
23.0	15.4	197.59	23000	197.59	230	197.59	230	197.59	230	197.59	230
23.1	15.4	197.59	23100	197.59	231	197.59	231	197.59	231	197.59	231
23.2	15.4	197.59	23200	197.59	232	197.59	232	197.59	232	197.59	232
23.3	15.4	197.59	23300	197.59	233	197.59	233	197.59	233	197.59	233

P	•	•	○	
M			•	
K	•	•	•	•
N				•
S			•	
H				
O				

→ v_c Page 152–155

→ Application recommendation on page 162

Ø DC_{m7} for Type UNI, P, GG und AL / Ø DC_{h7} for Type VA

WTX – Drilling Head for Exchangeable drills

▲ extra long head type

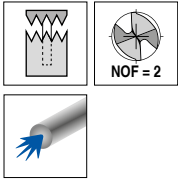

Change UNI	Change P	Change VA	Change GG	Change AL
DPX74S	Ti750	Ti700	TiSi	TiB

DRAGONSKIN

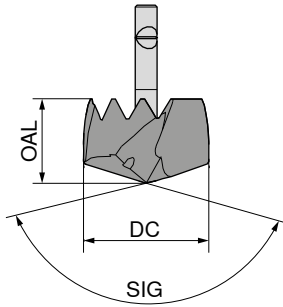

DC _{h7/m7} mm	OAL mm	10 919 ...		10 923 ...		10 921 ...		10 924 ...		10 922 ...	
		£	W2	£	W2	£	W2	£	W2	£	W2
23.4	15.4	197.59	23400	197.59	234	197.59	234	197.59	234	197.59	234
23.5	15.4	197.59	23500	197.59	235	197.59	235	197.59	235	197.59	235
23.6	15.4	197.59	23600	197.59	236	197.59	236	197.59	236	197.59	236
23.7	15.4	197.59	23700	197.59	237	197.59	237	197.59	237	197.59	237
23.8	15.4	197.59	23800	197.59	238	197.59	238	197.59	238	197.59	238
23.9	15.4	197.59	23900	197.59	239	197.59	239	197.59	239	197.59	239
24.0	15.4	197.59	24000	197.59	240	197.59	240	197.59	240	197.59	240
24.1	15.4	215.10	24100	206.98	241	228.56	241	206.98	241	228.56	241
24.2	15.4	215.10	24200	206.98	242	228.56	242	206.98	242	228.56	242
24.3	15.4	215.10	24300	206.98	243	228.56	243	206.98	243	228.56	243
24.4	15.4	215.10	24400	206.98	244	228.56	244	206.98	244	228.56	244
24.5	17.4	215.10	24500	215.10	245	228.56	245	215.10	245	228.56	245
24.6	17.4	215.10	24600	215.10	246	228.56	246	215.10	246	228.56	246
24.7	17.4	215.10	24700	215.10	247	228.56	247	215.10	247	228.56	247
24.8	17.4	215.10	24800	215.10	248	228.56	248	215.10	248	228.56	248
24.9	17.4	215.10	24900	215.10	249	228.56	249	215.10	249	228.56	249
25.0	17.4	215.10	25000	215.10	250	228.56	250	215.10	250	228.56	250
25.1	17.4	215.10	25100	215.10	251	228.56	251	215.10	251	228.56	251
25.2	17.4	215.10	25200	215.10	252	228.56	252	215.10	252	228.56	252
25.3	17.4	215.10	25300	215.10	253	228.56	253	215.10	253	228.56	253
25.4	17.4	215.10	25400	215.10	254	228.56	254	215.10	254	228.56	254
25.5	17.4	215.10	25500	215.10	255	228.56	255	215.10	255	228.56	255
25.6	17.4	228.56	25600	228.56	256	228.56	256	228.56	256	228.56	256
25.7	17.4	228.56	25700	228.56	257	228.56	257	228.56	257	228.56	257
25.8	17.4	228.56	25800	228.56	258	228.56	258	228.56	258	228.56	258
25.9	17.4	228.56	25900	228.56	259	228.56	259	228.56	259	228.56	259
26.0	17.4	228.56	26000	228.56	260	228.56	260	228.56	260	228.56	260
26.1	17.4	228.56	26100	228.56	261	228.56	261	228.56	261	228.56	261
26.2	17.4	228.56	26200	228.56	262	228.56	262	228.56	262	228.56	262
26.3	17.4	228.56	26300	228.56	263	228.56	263	228.56	263	228.56	263
26.4	17.4	228.56	26400	228.56	264	228.56	264	228.56	264	228.56	264
26.5	17.4	228.56	26500	228.56	265	228.56	265	228.56	265	228.56	265
26.6	17.4	228.56	26600	228.56	266	228.56	266	228.56	266	228.56	266
26.7	17.4	228.56	26700	228.56	267	228.56	267	228.56	267	228.56	267
26.8	17.4	228.56	26800	228.56	268	228.56	268	228.56	268	228.56	268
26.9	17.4	228.56	26900	228.56	269	228.56	269	228.56	269	228.56	269
27.0	17.4	228.56	27000	228.56	270	228.56	270	228.56	270	228.56	270
27.1	17.4	228.56	27100	228.56	271	228.56	271	228.56	271	228.56	271

P	●	●	○
M			●
K	●	●	●
N			●
S			●
H			
O			

→ v. Page 152–155

→ Application recommendation on page 162

Ø DC_{m7} for Type UNI, P, GG und AL / Ø DC_{h7} for Type VA

WTX – Drilling Head for Exchangeable drills

▲ extra long head type

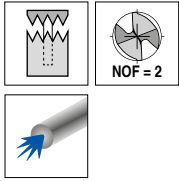

Change UNI	Change P	Change VA	Change GG	Change AL
DPX74S	Ti750	Ti700	TiSi	TiB

DRAGONSKIN

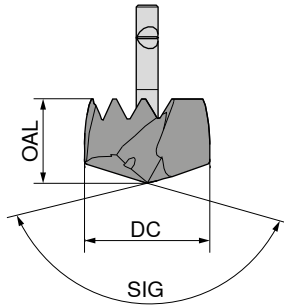

DC _{h7/m7} mm	OAL mm	10 919 ... Solid carbide		10 923 ... Solid carbide		10 921 ... Solid carbide		10 924 ... Solid carbide		10 922 ... Solid carbide	
		£ W2		£ W2		£ W2		£ W2		£ W2	
27.2	17.4	228.56	27200	228.56	272	228.56	272	228.56	272	228.56	272
27.3	17.4	228.56	27300	228.56	273	228.56	273	228.56	273	228.56	273
27.4	17.4	228.56	27400	228.56	274	228.56	274	228.56	274	228.56	274
27.5	17.4	228.56	27500	228.56	275	228.56	275	228.56	275	228.56	275
27.6	17.4	228.56	27600	228.56	276	228.56	276	228.56	276	228.56	276
27.7	17.4	228.56	27700	228.56	277	228.56	277	228.56	277	228.56	277
27.8	17.4	228.56	27800	228.56	278	228.56	278	228.56	278	228.56	278
27.9	17.4	228.56	27900	228.56	279	228.56	279	228.56	279	228.56	279
28.0	17.4	228.56	28000	228.56	280	228.56	280	228.56	280	228.56	280
28.1	17.4	249.96	28100	249.96	281	249.96	281	249.96	281	249.96	281
28.2	17.4	249.96	28200	249.96	282	249.96	282	249.96	282	249.96	282
28.3	17.4	249.96	28300	249.96	283	249.96	283	249.96	283	249.96	283
28.4	17.4	249.96	28400	249.96	284	249.96	284	249.96	284	249.96	284
28.5	18.4	249.96	28500	249.96	285	249.96	285	249.96	285	249.96	285
28.6	18.4	249.96	28600	249.96	286	249.96	286	249.96	286	249.96	286
28.7	18.4	249.96	28700	249.96	287	249.96	287	249.96	287	249.96	287
28.8	18.4	249.96	28800	249.96	288	249.96	288	249.96	288	249.96	288
28.9	18.4	249.96	28900	249.96	289	249.96	289	249.96	289	249.96	289
29.0	18.4	249.96	29000	249.96	290	249.96	290	249.96	290	249.96	290
29.1	18.4	249.96	29100	249.96	291	249.96	291	249.96	291	249.96	291
29.2	18.4	249.96	29200	249.96	292	249.96	292	249.96	292	249.96	292
29.3	18.4	249.96	29300	249.96	293	249.96	293	249.96	293	249.96	293
29.4	18.4	249.96	29400	249.96	294	249.96	294	249.96	294	249.96	294
29.5	18.4	249.96	29500	249.96	295	249.96	295	249.96	295	249.96	295
29.6	18.4	249.96	29600	249.96	296	249.96	296	249.96	296	249.96	296
29.7	18.4	249.96	29700	249.96	297	249.96	297	249.96	297	249.96	297
29.8	18.4	249.96	29800	249.96	298	249.96	298	249.96	298	249.96	298
29.9	18.4	249.96	29900	249.96	299	249.96	299	249.96	299	249.96	299
30.0	18.4	249.96	30000	249.96	300	249.96	300	249.96	300	249.96	300
30.1	18.4	278.92	30100	278.92	301	278.92	301	278.92	301	278.92	301
30.2	18.4	278.92	30200	278.92	302	278.92	302	278.92	302	278.92	302
30.3	18.4	278.92	30300	278.92	303	278.92	303	278.92	303	278.92	303
30.4	18.4	278.92	30400	278.92	304	278.92	304	278.92	304	278.92	304
30.5	18.4	278.92	30500	278.92	305	278.92	305	278.92	305	278.92	305
30.6	18.4	278.92	30600	278.92	306	278.92	306	278.92	306	278.92	306
30.7	18.4	278.92	30700	278.92	307	278.92	307	278.92	307	278.92	307
30.8	18.4	278.92	30800	278.92	308	278.92	308	278.92	308	278.92	308
30.9	18.4	278.92	30900	278.92	309	278.92	309	278.92	309	278.92	309

P	●	●	○	
M			●	
K	●	●	●	●
N				●
S			●	
H				
O				

→ v. Page 152-155

→ Application recommendation on page 162

Ø DC_{m7} for Type UNI, P, GG und AL / Ø DC_{h7} for Type VA

WTX – Drilling Head for Exchangeable drills

▲ extra long head type

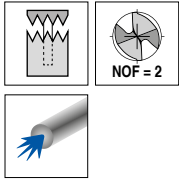

Change UNI	Change P	Change VA	Change GG	Change AL
DPX74S	Ti750	Ti700	TiSi	TiB

DRAGONSKIN

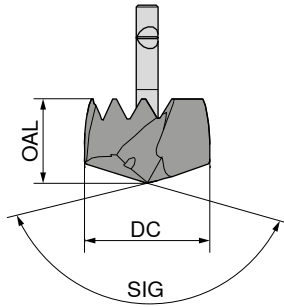

DC _{m7/m7} mm	OAL mm	SIG 140° Solid carbide		SIG 138° Solid carbide		SIG 138° Solid carbide		SIG 140° Solid carbide		SIG 140° Solid carbide	
		10 919 ...	10 923 ...	10 921 ...	10 924 ...	10 922 ...					
		£ W2	£ W2	£ W2	£ W2	£ W2	£ W2	£ W2	£ W2	£ W2	
31.0	18.4	278.92 31000	278.92 310	278.92 310	278.92 310	278.92 310	278.92 310	278.92 310	278.92 310	278.92 310	
31.1	18.4	278.92 31100	278.92 311	278.92 311	278.92 311	278.92 311	278.92 311	278.92 311	278.92 311	278.92 311	
31.2	18.4	278.92 31200	278.92 312	278.92 312	278.92 312	278.92 312	278.92 312	278.92 312	278.92 312	278.92 312	
31.3	18.4	278.92 31300	278.92 313	278.92 313	278.92 313	278.92 313	278.92 313	278.92 313	278.92 313	278.92 313	
31.4	18.4	278.92 31400	278.92 314	278.92 314	278.92 314	278.92 314	278.92 314	278.92 314	278.92 314	278.92 314	
31.5	18.4	278.92 31500	278.92 315	278.92 315	278.92 315	278.92 315	278.92 315	278.92 315	278.92 315	278.92 315	
31.6	18.4	278.92 31600	278.92 316	278.92 316	278.92 316	278.92 316	278.92 316	278.92 316	278.92 316	278.92 316	
31.7	18.4	278.92 31700	278.92 317	278.92 317	278.92 317	278.92 317	278.92 317	278.92 317	278.92 317	278.92 317	
31.8	18.4	278.92 31800	278.92 318	278.92 318	278.92 318	278.92 318	278.92 318	278.92 318	278.92 318	278.92 318	
31.9	18.4	278.92 31900	278.92 319	278.92 319	278.92 319	278.92 319	278.92 319	278.92 319	278.92 319	278.92 319	
32.0	18.4	278.92 32000	278.92 320	278.92 320	278.92 320	278.92 320	278.92 320	278.92 320	278.92 320	278.92 320	
32.5	24.3	298.56 32500	298.56 325								
33.0	24.3	298.56 33000	298.56 330								
33.5	24.3	298.56 33500	298.56 335								
34.0	24.3	298.56 34000	298.56 340								
34.5	24.3	298.56 34500	298.56 345								
35.0	24.3	298.56 35000	298.56 350								
35.5	26.3	341.48 35500	341.48 355								
36.0	26.3	341.48 36000	341.48 360								
36.5	26.3	341.48 36500	341.48 365								
37.0	26.3	341.48 37000	341.48 370								
37.5	26.3	341.48 37500	341.48 375								
38.0	26.3	341.48 38000	341.48 380								
38.5	26.3	371.17 38500	371.17 385								
39.0	26.3	371.17 39000	371.17 390								
39.5	26.3	371.17 39500	371.17 395								
40.0	26.3	371.17 40000	371.17 400								
40.5	26.3	371.17 40500	371.17 405								
41.0	26.3	371.17 41000	371.17 410								

P	●	●	○		
M			●		
K	●	●	●	●	
N					●
S			●		
H					
O					

→ v_c Page 152–155
→ Application recommendation on page 162

Ø DC_{m7} for Type UNI, P, GG und AL / Ø DC_{n7} for Type VA

When changing the head, please observe the specified tightening torque.

WTX – Holder for Exchangeable drills

▲ with radial teeth

Scope of supply:

Holder incl. screw driver

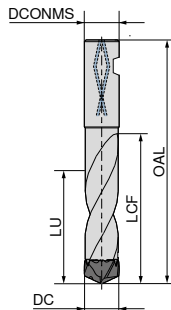
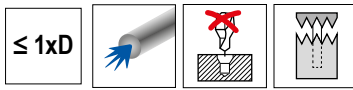

Change



10 911 ...

DC mm	DCONMS _{h6} mm	OAL mm	LCF mm	LU mm	torque moment Nm	£ W1	
12,00 - 12,49	14	81	29	12.5	1.0	298.56	120
12,50 - 12,99	14	81	29	13.0	1.0	298.56	125
13,00 - 13,49	14	81	31	13.5	1.0	298.56	130
13,50 - 13,99	16	86	32	14.0	1.3	298.56	135
14,00 - 14,49	16	86	33	14.5	1.3	298.56	140
14,50 - 14,99	16	91	34	15.0	1.3	298.56	145
15,00 - 15,49	16	91	36	15.5	1.3	298.56	150
15,50 - 16,49	20	97	38	16.5	1.3	308.47	161
15,50 - 16,49	18	92	38	16.5	1.3	308.47	160
16,50 - 17,49	20	99	40	17.5	3.5	308.47	166
16,50 - 17,49	18	94	40	17.5	3.5	308.47	165
17,50 - 18,49	20	104	43	18.5	3.5	308.47	176
17,50 - 18,49	18	99	43	18.5	3.5	308.47	175
18,50 - 19,49	20	99	45	19.5	3.5	364.56	185
19,50 - 20,49	20	104	47	20.5	3.5	364.56	195
20,50 - 21,49	25	111	49	21.5	3.5	404.14	205
21,50 - 22,49	25	116	52	22.5	3.5	404.14	215
22,50 - 23,49	25	116	54	23.5	3.5	442.11	225
23,50 - 24,49	25	121	56	24.5	4.0	442.11	235
24,50 - 25,49	25	123	59	25.5	4.0	480.02	245
25,50 - 26,49	25	123	61	26.5	4.0	480.02	255
26,50 - 27,49	25	128	63	27.5	4.0	480.02	265
27,50 - 28,49	25	128	66	28.5	4.0	480.02	275
28,50 - 29,49	32	134	68	29.5	4.0	557.55	285
29,50 - 30,49	32	139	70	30.5	4.0	557.55	295
30,50 - 31,49	32	139	75	31.5	4.0	615.29	305
31,50 - 32,49	32	139	75	32.5	4.0	615.29	315
32,50 - 33,49	32	150	78	33.5	6.0	663.13	325
33,50 - 34,49	32	150	79	34.5	6.0	663.13	335
34,50 - 35,49	32	150	82	35.5	6.0	663.13	345
35,50 - 37,49	32	152	86	37.5	6.0	763.75	355
37,50 - 39,49	32	157	91	39.5	6.0	791.81	375
39,50 - 41,00	32	167	95	41.5	6.0	811.60	395

WTX – Holder for Exchangeable drills

▲ with radial teeth

Scope of supply:

Holder incl. screw driver

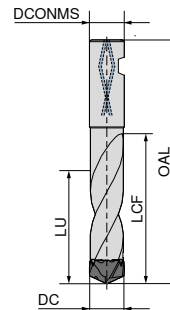
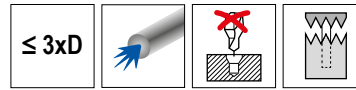

Change



10 913 ...

DC mm	DCONMS _{h6} mm	OAL mm	LCF mm	LU mm	torque moment Nm	£ W1	
12,00 - 12,49	14	100	53	38.0	1.0	337.58	120
12,50 - 12,99	14	105	55	39.0	1.0	337.58	125
13,00 - 13,49	14	105	57	40.0	1.0	337.58	130
13,50 - 13,99	16	110	59	42.0	1.3	337.58	135
14,00 - 14,49	16	115	61	43.0	1.3	337.58	140
14,50 - 14,99	16	115	63	45.0	1.3	337.58	145
15,00 - 15,49	16	115	65	46.0	1.3	337.58	150
15,50 - 16,49	18	120	70	50.0	1.3	329.29	160
15,50 - 16,49	20	125	70	50.0	1.3	329.29	161
16,50 - 17,49	18	125	74	53.0	3.5	329.29	165
16,50 - 17,49	20	130	74	50.0	3.5	329.29	166
17,50 - 18,49	18	130	78	55.0	3.5	329.29	175
17,50 - 18,49	20	135	78	50.0	3.5	329.29	176
18,50 - 19,49	20	135	82	58.0	3.5	389.42	185
19,50 - 20,49	20	140	87	62.0	3.5	389.42	195
20,50 - 21,49	25	150	91	65.0	3.5	430.01	205
21,50 - 22,49	25	155	95	67.0	3.5	430.01	215
22,50 - 23,49	25	160	99	70.0	3.5	470.77	225
23,50 - 24,49	25	165	103	73.0	3.5	470.77	235
24,50 - 25,49	25	165	108	77.0	4.0	511.32	245
25,50 - 26,49	25	175	112	80.0	4.0	511.32	255
26,50 - 27,49	25	175	116	82.0	4.0	511.32	265
27,50 - 28,49	25	180	120	85.0	4.0	511.32	275
28,50 - 29,49	32	190	124	88.0	4.0	592.70	285
29,50 - 30,49	32	195	129	92.0	4.0	592.70	295
30,50 - 31,49	32	195	133	94.0	4.0	654.68	305
31,50 - 32,49	32	200	137	97.0	4.0	654.68	315
32,50 - 33,49	32	210	144	100.5	6.0	772.00	325
33,50 - 34,49	32	215	148	103.5	6.0	772.00	335
34,50 - 35,49	32	220	153	106.5	6.0	772.00	345
35,50 - 37,49	32	227	161	112.5	6.0	887.47	355
37,50 - 39,49	32	237	170	118.5	6.0	920.48	375
39,50 - 41,00	32	247	178	124.5	6.0	943.57	395



Screw driver

80 950 ...

DC	SW	£ Y7	
12,00 - 12,49	SW 1,3	4.56	132
12,50 - 13,49	SW 1,3	4.56	132
13,50 - 14,49			
14,50 - 16,49			
16,50 - 20,49			
20,50 - 24,49			
24,50 - 28,49			
28,50 - 32,49			
32,50 - 35,49			
35,50 - 39,49			
39,50 - 41,00			



Screw driver

80 950 ...

SW	£ Y7	
SW 1,5	5.93	133
SW 1,5	5.93	133
SW 2	5.64	134
SW 2	5.64	134
SW 2,5	5.30	135
SW 2,5	5.30	135
SW 3	5.30	136
SW 3	5.30	136
SW 3	5.30	136



Grub screw

10 950 ...

Grub screw	£ W1	
M2,5 x 0,45 x 5	5.28	025
M2,5 x 0,45 x 6	5.28	026
M3 x 0,5 x 6	5.28	031
M3 x 0,5 x 7	5.45	030
M4 x 0,5 x 7,5	5.45	040
M4 x 0,5 x 10	5.45	041
M5 x 0,5 x 11	5.45	050
M5 x 0,5 x 14	5.45	051
M6 x 0,5 x 16	9.73	060
M6 x 0,5 x 18	9.73	061
M6 x 0,5 x 20	9.73	062

WTX – Holder for Exchangeable drills

▲ with radial teeth

Scope of supply:

Holder incl. screw driver

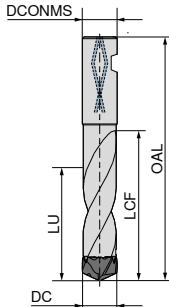
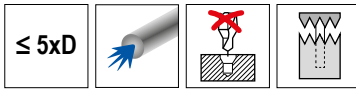

10 915 ...

DC mm	DCONMS _{h6} mm	OAL mm	LCF mm	LU mm	torque moment Nm	£ W1	
12,00 - 12,49	14	125	78	62.0	1,0	380.02	120
12,50 - 12,99	14	130	81	65.0	1,0	380.02	125
13,00 - 13,49	14	130	84	67.0	1,0	380.02	130
13,50 - 13,99	16	140	88	70.0	1,3	380.02	135
14,00 - 14,49	16	140	90	72.0	1,3	380.02	140
14,50 - 14,99	16	145	94	75.0	1,3	380.02	145
15,00 - 15,49	16	145	96	77.0	1,3	380.02	150
15,50 - 16,49	18	155	103	82.0	1,3	389.42	160
15,50 - 16,49	20	160	103	82.0	1,3	389.42	161
16,50 - 17,49	18	160	109	87.0	3,5	389.42	165
16,50 - 17,49	20	165	109	87.0	3,5	389.42	166
17,50 - 18,49	18	165	115	92.0	3,5	389.42	175
17,50 - 18,49	20	170	115	92.0	3,5	389.42	176
18,50 - 19,49	20	175	121	97.0	3,5	451.39	185
19,50 - 20,49	20	180	128	102.0	3,5	451.39	195
20,50 - 21,49	25	195	134	107.0	3,5	490.14	205
21,50 - 22,49	25	200	140	112.0	3,5	490.14	215
22,50 - 23,49	25	205	146	117.0	3,5	532.74	225
23,50 - 24,49	25	210	152	122.0	3,5	532.74	235
24,50 - 25,49	25	220	159	127.0	4,0	573.34	245
25,50 - 26,49	25	225	165	132.0	4,0	573.34	255
26,50 - 27,49	25	230	171	137.0	4,0	573.34	265
27,50 - 28,49	25	240	177	142.0	4,0	573.34	275
28,50 - 29,49	32	250	183	146.0	4,0	654.68	285
29,50 - 30,49	32	255	190	152.0	4,0	654.68	295
30,50 - 31,49	32	260	196	157.0	4,0	714.79	305
31,50 - 32,49	32	265	202	162.0	4,0	714.79	315
32,50 - 33,49	32	275	210	167.5	6,0	872.62	325
33,50 - 34,49	32	285	217	172.5	6,0	872.62	335
34,50 - 35,49	32	290	224	177.5	6,0	872.62	345
35,50 - 37,49	32	302	236	187.5	6,0	981.48	355
37,50 - 39,49	32	317	249	197.5	6,0	1,017.81	375
39,50 - 41,00	32	327	261	207.5	6,0	1,040.86	395

WTX – Holder for Exchangeable drills

▲ Pilot hole is recommended

▲ With radial teeth

Scope of supply:

Holder incl. screw driver

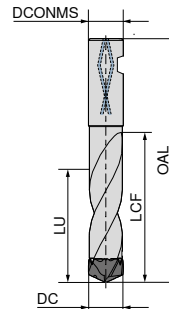
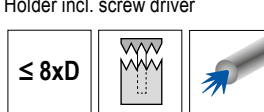

10 918 ...

DC mm	DCONMS _{h6} mm	OAL mm	LCF mm	LU mm	torque moment Nm	£ W1	
12,00 - 12,49	14	165	116	100	1,0	483.31	120
12,50 - 12,99	14	170	121	104	1,0	483.31	125
13,00 - 13,49	14	175	126	108	1,0	483.31	130
13,50 - 13,99	16	180	129	111	1,3	483.31	135
14,00 - 14,49	16	185	134	115	1,3	483.31	140
14,50 - 14,99	16	190	139	120	1,3	483.31	145
15,00 - 15,49	16	195	144	124	1,3	483.31	150
15,50 - 16,49	18	205	152	131	1,3	492.53	160
15,50 - 16,49	20	210	152	131	1,3	492.53	161
16,50 - 17,49	18	215	161	138	3,5	492.53	165
16,50 - 17,49	20	220	161	138	3,5	492.53	166
17,50 - 18,49	18	220	171	147	3,5	492.53	175
17,50 - 18,49	20	225	171	147	3,5	492.53	176
18,50 - 19,49	20	235	180	155	3,5	566.32	185
19,50 - 20,49	20	240	189	163	3,5	566.32	195
20,50 - 21,49	25	260	198	170	3,5	616.12	205
21,50 - 22,49	25	270	207	178	3,5	616.12	215
22,50 - 23,49	25	275	217	187	3,5	691.76	225
23,50 - 24,49	25	285	226	194	3,5	691.76	235
24,50 - 25,49	25	295	235	202	4,0	791.35	245
25,50 - 26,49	25	305	244	210	4,0	791.35	255
26,50 - 27,49	25	315	253	218	4,0	791.35	265
27,50 - 28,49	25	325	263	226	4,0	791.35	275
28,50 - 29,49	32	340	272	234	4,0	914.95	285
29,50 - 30,49	32	345	281	242	4,0	914.95	295
30,50 - 31,49	32	355	290	249	4,0	1,014.58	305
31,50 - 32,00	32	360	299	257	4,0	1,014.58	315



Screw driver

80 950 ...

Spare parts DC	£ Y7	
12,00 - 12,49	4.56	132
12,50 - 13,49	4.56	132
13,50 - 14,49		
14,50 - 16,49		
16,50 - 20,49		
20,50 - 24,49		
24,50 - 28,49		
28,50 - 32,49		
32,50 - 35,49		
35,50 - 39,49		
39,50 - 41,00		

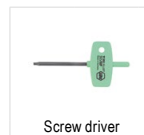

Screw driver

80 950 ...

£ Y7	
5.93	133
5.93	133
5.64	134
5.64	134
5.30	135
5.30	135
5.30	136
5.30	136
5.30	136

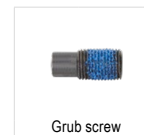

Grub screw

10 950 ...

£ W1	
5.28	025
5.28	026
5.28	031
5.45	030
5.45	040
5.45	041
5.45	050
5.45	051
9.73	060
9.73	061
9.73	062

WTX – Holder for Exchangeable drills

- ▲ Pilot hole is recommended
- ▲ With radial teeth

Scope of supply:

Holder incl. screw driver

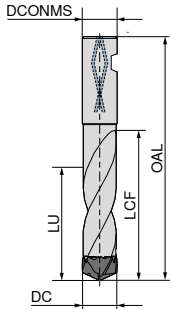
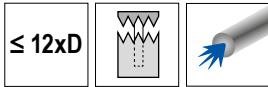

10 912 ...

DC mm	DCONMS _{h6} mm	OAL mm	LCF mm	LU mm	torque moment Nm	£ W1	
12,00 - 12,49	14	210	162	150	1,0	638.48	12000
12,50 - 12,99	14	216	168	156	1,0	638.48	12500
13,00 - 13,49	14	223	175	162	1,0	638.48	13000
13,50 - 13,99	16	235	182	168	1,3	638.48	13500
14,00 - 14,49	16	242	189	174	1,3	638.48	14000
14,50 - 14,99	16	248	195	180	1,3	638.48	14500
15,00 - 15,49	16	255	202	186	1,3	638.48	15000
15,50 - 16,49	18	262	209	198	1,3	695.53	15500
16,50 - 17,49	18	275	222	210	3,5	695.53	16500
17,50 - 18,49	18	289	236	222	3,5	695.53	17500
18,50 - 19,49	20	304	249	234	3,5	842.74	18500
19,50 - 20,49	20	318	263	246	3,5	842.74	19500
20,50 - 21,49	25	337	276	258	3,5	910.35	20500
21,50 - 22,49	25	351	290	270	3,5	910.35	21500
22,50 - 23,49	25	364	303	282	3,5	1,011.53	22500
23,50 - 24,49	25	378	317	294	3,5	1,011.53	23500
24,50 - 25,49	25	391	330	306	4,0	1,146.59	24500
25,50 - 26,49	25	405	344	318	4,0	1,146.59	25500
26,50 - 27,49	25	418	357	330	4,0	1,146.59	26500
27,50 - 28,49	25	432	371	342	4,0	1,146.59	27500
28,50 - 29,49	32	449	384	354	4,0	1,314.92	28500
29,50 - 30,49	32	463	398	366	4,0	1,314.92	29500
30,50 - 31,49	32	476	411	378	4,0	1,450.13	30500
31,50 - 32,00	32	490	425	390	4,0	1,450.13	31500

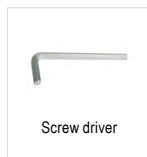

80 950 ...

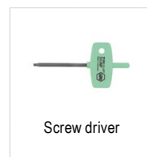

80 950 ...

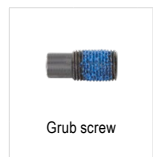

10 950 ...

Spare parts

DC		£ Y7		£ W1	
12,00 - 12,49	SW 1,3	4.56	132		M2,5 x 0,45 x 5 5.28 025
12,50 - 13,49	SW 1,3	4.56	132		M2,5 x 0,45 x 6 5.28 026
13,50 - 14,49				SW 1,5 5.93 133	M3 x 0,5 x 6 5.28 031
14,50 - 16,49				SW 1,5 5.93 133	M3 x 0,5 x 7 5.45 030
16,50 - 20,49				SW 2 5.64 134	M4 x 0,5 x 7,5 5.45 040
20,50 - 24,49				SW 2 5.64 134	M4 x 0,5 x 10 5.45 041
24,50 - 28,49				SW 2,5 5.30 135	M5 x 0,5 x 11 5.45 050
28,50 - 32,49				SW 2,5 5.30 135	M5 x 0,5 x 14 5.45 051
32,50 - 35,49				SW 3 5.30 136	M6 x 0,5 x 16 9.73 060
35,50 - 39,49				SW 3 5.30 136	M6 x 0,5 x 18 9.73 061
39,50 - 41,00				SW 3 5.30 136	M6 x 0,5 x 20 9.73 062

WPC – Indexable insert for indexable insert drill

Scope of supply:

Indexable insert (clamping screws can be ordered separately, if necessary)



NEW

Change UNI

TPX74S

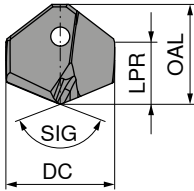

SIG 135°
HM

11 910 ...

DC _{m7} mm	OAL mm	LPR mm	S mm	£ TS
14.0	12.8	7.73	5.00	85.26 14000
14.1	12.8	7.73	5.00	85.26 14100
14.2	12.8	7.73	5.00	85.26 14200
14.3	12.8	7.73	5.00	85.26 14300
14.4	12.8	7.73	5.00	85.26 14400
14.5	13.1	7.84	5.00	85.26 14500
14.6	13.1	7.84	5.00	85.26 14600
14.7	13.1	7.84	5.00	85.26 14700
14.8	13.1	7.84	5.00	86.58 14800
14.9	13.1	7.84	5.00	86.58 14900
15.0	13.4	7.95	5.00	86.58 15000
15.1	13.4	7.95	5.00	86.58 15100
15.2	13.4	7.95	5.00	86.58 15200
15.3	13.4	7.95	5.00	86.58 15300
15.4	13.4	7.95	5.00	86.58 15400
15.5	13.7	8.05	5.00	86.58 15500
15.6	13.7	8.05	5.00	86.58 15600
15.7	13.7	8.05	5.00	86.58 15700
15.8	13.7	8.05	5.00	91.84 15800
15.9	13.7	8.05	5.00	91.84 15900
16.0	14.4	9.06	5.80	91.84 16000
16.1	14.4	9.06	5.80	91.84 16100
16.2	14.4	9.06	5.80	91.84 16200
16.3	14.4	9.06	5.80	91.84 16300
16.4	14.4	9.06	5.80	91.84 16400
16.5	14.7	9.17	5.80	91.84 16500
16.6	14.7	9.17	5.80	91.84 16600
16.7	14.7	9.17	5.80	91.84 16700
16.8	14.7	9.17	5.80	94.03 16800
16.9	14.7	9.17	5.80	94.03 16900
17.0	15.0	9.28	5.80	94.03 17000
17.1	15.0	9.28	5.80	94.03 17100
17.2	15.0	9.28	5.80	94.03 17200
17.3	15.0	9.28	5.80	94.03 17300
17.4	15.0	9.28	5.80	94.03 17400
17.5	15.3	9.39	5.80	94.03 17500
17.6	15.3	9.39	5.80	94.03 17600
17.7	15.3	9.39	5.80	94.03 17700
17.8	15.3	9.39	5.80	96.23 17800
17.9	15.3	9.39	5.80	96.23 17900
18.0	16.3	10.19	6.50	96.23 18000
18.1	16.3	10.19	6.50	96.23 18100
18.2	16.3	10.19	6.50	96.23 18200
18.3	16.3	10.19	6.50	96.23 18300
18.4	16.3	10.19	6.50	96.23 18400
18.5	16.6	10.30	6.50	96.23 18500
18.6	16.6	10.30	6.50	96.23 18600
18.7	16.6	10.30	6.50	96.23 18700
18.8	16.6	10.30	6.50	99.06 18800
18.9	16.6	10.30	6.50	99.06 18900
19.0	16.9	10.41	6.50	99.06 19000
19.1	16.9	10.41	6.50	99.06 19100
19.2	16.9	10.41	6.50	99.06 19200
19.3	16.9	10.41	6.50	99.06 19300
19.4	16.9	10.41	6.50	99.06 19400
19.5	17.2	10.52	6.50	99.06 19500
19.6	17.2	10.52	6.50	99.06 19600
19.7	17.2	10.52	6.50	99.06 19700
19.8	17.2	10.52	6.50	102.33 19800
19.9	17.2	10.52	6.50	102.33 19900

11 910 ...

DC _{m7} mm	OAL mm	LPR mm	S mm	£ TS
20.0	18.2	11.33	7.20	102.33 20000
20.1	18.2	11.33	7.20	102.33 20100
20.2	18.2	11.33	7.20	102.33 20200
20.3	18.2	11.33	7.20	102.33 20300
20.4	18.2	11.33	7.20	102.33 20400
20.5	18.5	11.43	7.20	102.33 20500
20.6	18.5	11.43	7.20	102.33 20600
20.7	18.5	11.43	7.20	102.33 20700
20.8	18.5	11.43	7.20	105.20 20800
20.9	18.5	11.43	7.20	105.20 20900
21.0	18.8	11.54	7.20	105.20 21000
21.1	18.8	11.54	7.20	105.20 21100
21.2	18.8	11.54	7.20	105.20 21200
21.3	18.8	11.54	7.20	105.20 21300
21.4	18.8	11.54	7.20	105.20 21400
21.5	19.1	11.65	7.20	105.20 21500
21.6	19.1	11.65	7.20	105.20 21600
21.7	19.1	11.65	7.20	105.20 21700
21.8	19.1	11.65	7.20	107.66 21800
21.9	19.1	11.65	7.20	107.66 21900
22.0	20.2	12.56	7.90	107.66 22000
22.1	20.2	12.56	7.90	107.66 22100
22.2	20.2	12.56	7.90	107.66 22200
22.3	20.2	12.56	7.90	107.66 22300
22.4	20.2	12.56	7.90	107.66 22400
22.5	20.5	12.67	7.90	107.66 22500
22.6	20.5	12.67	7.90	107.66 22600
22.7	20.5	12.67	7.90	107.66 22700
22.8	20.5	12.67	7.90	111.73 22800
22.9	20.5	12.67	7.90	111.73 22900
23.0	20.8	12.78	7.90	111.73 23000
23.1	20.8	12.78	7.90	111.73 23100
23.2	20.8	12.78	7.90	111.73 23200
23.3	20.8	12.78	7.90	111.73 23300
23.4	20.8	12.78	7.90	111.73 23400
23.5	21.1	12.88	7.90	111.73 23500
23.6	21.1	12.88	7.90	111.73 23600
23.7	21.1	12.88	7.90	111.73 23700
23.8	21.1	12.88	7.90	117.76 23800
23.9	21.1	12.88	7.90	117.76 23900
24.0	22.1	13.69	8.60	117.76 24000
24.1	22.1	13.69	8.60	117.76 24100
24.2	22.1	13.69	8.60	117.76 24200
24.3	22.1	13.69	8.60	117.76 24300
24.4	22.1	13.69	8.60	117.76 24400
24.5	22.4	13.80	8.60	117.76 24500
24.6	22.4	13.80	8.60	117.76 24600
24.7	22.4	13.80	8.60	117.76 24700
24.8	22.4	13.80	8.60	124.52 24800
24.9	22.4	13.80	8.60	124.52 24900
25.0	22.7	13.91	8.60	124.52 25000
25.1	22.7	13.91	8.60	124.52 25100
25.2	22.7	13.91	8.60	124.52 25200
25.3	22.7	13.91	8.60	124.52 25300
25.4	22.7	13.91	8.60	124.52 25400
25.5	23.0	14.02	8.60	124.52 25500
25.6	23.0	14.02	8.60	124.52 25600
25.7	23.0	14.02	8.60	124.52 25700
25.8	23.0	14.02	8.60	130.97 25800
25.9	23.0	14.02	8.60	130.97 25900
26.0	24.1	14.92	9.40	130.97 26000
26.5	24.4	15.03	9.40	130.97 26500
27.0	24.7	15.14	9.40	140.85 27000
27.5	25.0	15.25	9.40	140.85 27500
28.0	25.3	15.36	9.40	140.85 28000
28.5	25.6	15.47	9.40	146.87 28500
29.0	25.9	15.57	9.40	146.87 29000
29.5	26.2	15.68	9.40	152.35 29500
30.0	26.2	15.49	9.40	152.35 30000

P	●
M	
K	●
N	
S	
H	
O	

→ v. Page 157

→ Application recommendation on page 163



When changing inserts, please observe the specified tightening torque.

WPC – Holder for indexable insert drill

- ▲ Easy handling
- ▲ Insert can be changed in the machine
- ▲ Precise and stable insert seat, clamping via Torx Plus® screw

Scope of supply:

Holder incl. clamping screw

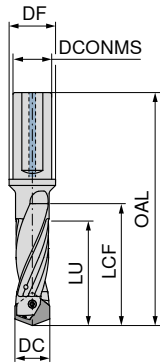
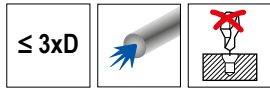

11 903 ...

DC mm	DCONMS mm	OAL mm	LCF mm	LU mm	DF mm	torque moment Nm	£ TT
14,00 - 14,49	16	108.9	50.8	43.5	20	0.9	251.18 14000
14,50 - 14,99	16	111.0	52.5	45.0	20	0.9	251.18 14500
15,00 - 15,49	20	115.1	54.3	46.5	25	0.9	251.18 15000
15,50 - 15,99	20	117.2	56.0	48.0	25	0.9	251.18 15500
16,00 - 16,49	20	119.3	57.8	49.5	25	1.2	275.60 16000
16,50 - 16,99	20	121.4	59.5	51.0	25	1.2	275.60 16500
17,00 - 17,49	20	123.5	61.3	52.5	25	1.2	275.60 17000
17,50 - 17,99	20	125.6	63.0	54.0	25	1.2	275.60 17500
18,00 - 18,49	20	127.7	64.8	55.5	25	2.2	293.82 18000
18,50 - 18,99	20	129.8	66.5	57.0	25	2.2	293.82 18500
19,00 - 19,49	25	137.9	68.3	58.5	30	2.2	293.82 19000
19,50 - 19,99	25	140.0	70.0	60.0	30	2.2	293.82 19500
20,00 - 20,49	25	142.1	71.8	61.5	30	2.2	312.04 20000
20,50 - 20,99	25	144.2	73.5	63.0	30	2.2	312.04 20500
21,00 - 21,49	25	146.3	75.3	64.5	30	2.2	339.38 21000
21,50 - 21,99	25	148.4	77.0	66.0	30	2.2	344.29 21500
22,00 - 22,49	25	150.5	78.8	67.5	30	3.2	349.09 22000
22,50 - 22,99	25	152.6	80.5	69.0	30	3.2	353.87 22500
23,00 - 23,49	25	154.7	82.3	70.5	30	3.2	358.89 23000
23,50 - 23,99	25	156.8	84.0	72.0	30	3.2	363.69 23500
24,00 - 24,49	32	162.9	85.8	73.5	39	5	368.48 24000
24,50 - 24,99	32	165.0	87.5	75.0	39	5	373.37 24500
25,00 - 25,49	32	167.1	89.3	76.5	39	5	378.16 25000
25,50 - 25,99	32	169.2	91.0	78.0	39	5	383.08 25500
26,00 - 26,49	32	171.3	92.8	79.5	39	6	387.87 26000
26,50 - 26,99	32	173.4	94.5	81.0	39	6	392.77 26500
27,00 - 27,49	32	175.5	96.3	82.5	39	6	397.56 27000
27,50 - 27,99	32	177.6	98.0	84.0	39	6	402.35 27500
28,00 - 28,49	32	179.7	99.8	85.5	39	6	407.37 28000
28,50 - 28,99	32	181.8	101.5	87.0	39	6	412.17 28500
29,00 - 29,49	32	183.9	103.3	88.5	39	6	416.95 29000
29,50 - 30,00	32	186.0	105.0	90.0	39	6	421.86 29500

WPC – Holder for indexable insert drill

- ▲ Easy handling
- ▲ Insert can be changed in the machine
- ▲ Precise and stable insert seat, clamping via Torx Plus® screw

Scope of supply:

Holder incl. clamping screw

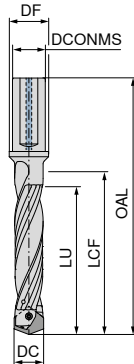
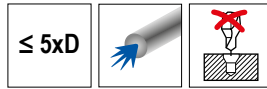

11 905 ...

DC mm	DCONMS mm	OAL mm	LCF mm	LU mm	DF mm	torque moment Nm	£ TT
14,00 - 14,49	16	137.9	79.8	72.5	20	0.9	272.21 14000
14,50 - 14,99	16	141.0	82.5	75.0	20	0.9	272.21 14500
15,00 - 15,49	20	146.1	85.3	77.5	25	0.9	272.21 15000
15,50 - 15,99	20	149.2	88.0	80.0	25	0.9	272.21 15500
16,00 - 16,49	20	152.3	90.8	82.5	25	1.2	296.38 16000
16,50 - 16,99	20	155.4	93.5	85.0	25	1.2	296.38 16500
17,00 - 17,49	20	158.5	96.3	87.5	25	1.2	296.38 17000
17,50 - 17,99	20	161.6	99.0	90.0	25	1.2	296.38 17500
18,00 - 18,49	20	164.7	101.8	92.5	25	2.2	315.32 18000
18,50 - 18,99	20	167.8	104.5	95.0	25	2.2	315.32 18500
19,00 - 19,49	25	176.9	107.3	97.5	30	2.2	315.32 19000
19,50 - 19,99	25	180.0	110.0	100.0	30	2.2	315.32 19500
20,00 - 20,49	25	183.1	112.8	102.5	30	2.2	333.07 20000
20,50 - 20,99	25	186.2	115.5	105.0	30	2.2	333.07 20500
21,00 - 21,49	25	189.3	118.3	107.5	30	2.2	361.46 21000
21,50 - 21,99	25	192.4	121.0	110.0	30	2.2	366.25 21500
22,00 - 22,49	25	195.5	123.8	112.5	30	3.2	371.04 22000
22,50 - 22,99	25	198.6	126.5	115.0	30	3.2	375.96 22500
23,00 - 23,49	25	201.7	129.3	117.5	30	3.2	380.85 23000
23,50 - 23,99	25	204.8	132.0	120.0	30	3.2	385.64 23500
24,00 - 24,49	32	211.9	134.8	122.5	39	5	390.56 24000
24,50 - 24,99	32	215.0	137.5	125.0	39	5	395.35 24500
25,00 - 25,49	32	218.1	140.3	127.5	39	5	400.24 25000
25,50 - 25,99	32	221.2	143.0	130.0	39	5	405.16 25500
26,00 - 26,49	32	224.3	145.8	132.5	39	6	409.95 26000
26,50 - 26,99	32	227.4	148.5	135.0	39	6	414.74 26500
27,00 - 27,49	32	230.5	151.3	137.5	39	6	419.64 27000
27,50 - 27,99	32	233.6	154.0	140.0	39	6	424.55 27500
28,00 - 28,49	32	236.7	156.8	142.5	39	6	429.34 28000
28,50 - 28,99	32	239.8	159.5	145.0	39	6	434.13 28500
29,00 - 29,49	32	242.9	162.3	147.5	39	6	439.05 29000
29,50 - 30,00	32	246.0	165.0	150.0	39	6	443.83 29500

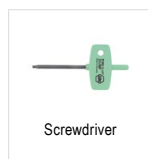

80 950 ...

Spare parts

DC		£ Y7	
14,00 - 15,99	T08 - IP	10.55	060
16,00 - 17,99	T08 - IP	10.55	060
18,00 - 21,99	T10 - IP	10.34	062
22,00 - 23,99	T10 - IP	10.34	062
24,00 - 25,99	T15 - IP	10.91	063
26,00 - 30,00	T20 - IP	12.14	064



80 950 ...

	£ Y7	
T08 - IP	8.49	043
T08 - IP	8.49	043
T10 - IP	8.49	053
T10 - IP	8.49	053
T15 - IP	8.49	054
T15 - IP	8.49	054
T20 - IP	8.49	055
T20 - IP	8.49	055

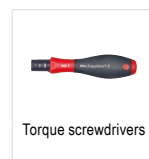

80 950 ...

	£ Y7	
0.5 - 2,0 Nm	207.73	191
0.5 - 2,0 Nm	207.73	191
2.0 - 7,0 Nm	232.67	193
2.0 - 7,0 Nm	232.67	193
2.0 - 7,0 Nm	232.67	193
2.0 - 7,0 Nm	232.67	193

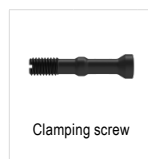

11 950 ...

	£ TT	
M2,2x13 - 08IP	11.00	00100
M2,5x15 - 08IP	11.00	00200
M3,0x17 - 10IP	11.76	00300
M3,5x21 - 10IP	11.76	00400
M4,0x23 - 15IP	11.76	00500
M4,5x25 - 20IP	13.86	00600

MultiChange – Programme Overview

The "MultiChange" interchangeable head system enables an extremely fast and problem free tool change. Provides quick changeover and concentricity with the highest stability at the same time. For a multitude of applications, the suitable interchangeable heads are available in the following chapters.

Exchangeable heads	
<p>→ Chapter 2, Solid carbide drilling</p> <p>Solid Carbide NC Spot Drills</p> <p>Ø 8, 10, 12, 16, 20 mm NOF 2</p> <p>SIG 90° SIG 120° SIG 142°</p>	<p>Page No. 2 107</p>
<p>→ Chapter 4, Reaming and countersinking</p> <p>Replaceable reaming heads</p> <p>Ø 8,00 – 30,20 mm</p> <p>Through hole</p> <p>Ø 12,20 – 30,20 mm</p> <p>Blind hole</p>	<p>Page No. 4 18 + 4 19</p>
<p>→ Chapter 14, Solid carbide milling cutters</p> <p>Solid carbide shoulder mills</p> <p>Ø 8, 10, 12, 16, 20 mm / ZEFP 3+4</p> <p>Type PCR-UNI Type PCR-ALU Type N</p> <p>Solid carbide torus bull nose milling cutters</p> <p>Ø 8, 10, 12, 16, 20 mm / ZEFP 3+4</p> <p>Type W Type N</p> <p>Solid carbide rough and finish milling cutters</p> <p>Ø 8, 10, 12, 16, 20 mm / ZEFP 4+6</p> <p>Type NF</p> <p>Solid carbide finish milling cutters</p> <p>Ø 8, 10, 12, 16, 20 mm / ZEFP 6</p> <p>Type N</p> <p>Solid carbide ball-nosed end mills</p> <p>Ø 10, 12, 16, 20 mm / ZEFP 4</p> <p>Type N</p> <p>Solid carbide high-feed cutters</p> <p>Ø 8, 10, 12, 16, 20 mm / ZEFP 6</p> <p>Type N</p> <p>Solid carbide quarter round cutter</p> <p>Ø 8, 10, 12, 16, 20 mm / ZEFP 6</p> <p>Type N</p> <p>Solid carbide deburring cutters</p> <p>Ø 10, 12, 16, 20 mm / ZEFP 4+6</p> <p>Type N Type N</p>	<p>Page No. 14 198 – 14 202</p>

NOF / ZEFP = Number of cutting edges

Tool holder
<p>→ Catalogue – Clamping technology, Chapter 16 Accessories</p> <p>Page No. 16 259 – 16 261</p> <p>extra short / OAL 60 – 90 mm</p> <p>Tapered 87° / Steel Cylindrical* / Steel</p> <p>short / OAL 85 – 120 mm</p> <p>Tapered 87° / Steel Cylindrical* / Steel</p> <p>Tapered 87° / Solid carbide Cylindrical* / Solid carbide</p> <p>medium / OAL 110 – 150 mm</p> <p>Tapered 87° / Solid carbide</p> <p>Cylindrical* / Solid carbide</p> <p>long / OAL 150 – 200 mm</p> <p>Tapered 87° / Solid carbide</p> <p>Cylindrical* / Steel</p> <p>Cylindrical* / Solid carbide</p> <p>extra long / OAL 200 – 250 mm</p> <p>Cylindrical* / Steel</p> <p>Cylindrical* / Solid carbide</p>

* only conditionally suitable for milling

MultiChange – NC Spot Drill

- ▲ SZID = Coupling Size
- ▲ NOF = No. of cutting edges

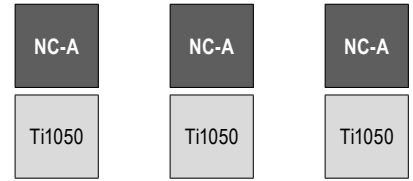
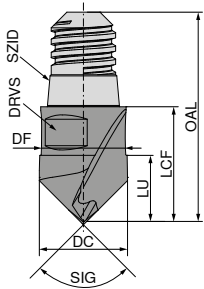

SIG 90° Solid carbide		SIG 120° Solid carbide		SIG 142° Solid carbide	
10 709 ...		10 712 ...		10 714 ...	
£	T7	£	T7	£	T7
41.03	080	41.03	080	41.03	080
45.46	100	45.46	100	45.46	100
58.33	120	58.33	120	58.33	120
82.50	160	82.50	160	82.50	160
120.01	200	120.01	200	120.01	200

DC mm	SZID	LU mm	DF mm	LCF mm	OAL mm	NOF	DRVS mm	torque moment Nm	a _{p max} mm
8	06	6.0	7.8	11	20.4	2	6	5	4
10	08	7.5	9.8	13	26.9	2	8	12,5	5
12	10	9.0	11.8	16	30.1	2	10	15	6
16	12	12.0	15.8	20	37.3	2	13	20	8
20	16	15.0	19.8	25	47.2	2	16	25	10

P	•	•	•
M	•	•	•
K	•	•	•
N	•	•	•
S			
H			
O			

→ v. Page 148

i Torque wrench should be used for coupling sizes 06 and 08
For unstable applications, the cutting data should be reduced.

Material examples for cutting data tables

	Material sub-group	Index	Composition / Structure / Heat treatment	Tensile strength N/mm ² / HB / HRC	Material number	Material designation	Material number	Material designation
P	Unalloyed steel	P.1.1	< 0,15 % C Annealed	420 N/mm ² / 125 HB	1.0401	C15	1.1141	Ck15
		P.1.2	< 0,45 % C Annealed	640 N/mm ² / 190 HB	1.1191	C45E	1.0718	9SMnPb28
		P.1.3	< 0,45 % C Tempered	840 N/mm ² / 250 HB	1.1191	C45E	1.0535	C55
		P.1.4	< 0,75 % C Annealed	910 N/mm ² / 270 HB	1.1223	C60R	1.0535	C55
		P.1.5	< 0,75 % C Tempered	1010 N/mm ² / 300 HB	1.1223	C60R	1.0727	45S20
	Low-alloy steel	P.2.1	Annealed	610 N/mm ² / 180 HB	1.7131	16MnCr5	1.6587	17CrNiMo6
		P.2.2	Tempered	930 N/mm ² / 275 HB	1.7131	16MnCr5	1.6587	17CrNiMo6
		P.2.3	Tempered	1010 N/mm ² / 300 HB	1.7225	42CrMo4	1.3505	100Cr6
		P.2.4	Tempered	1200 N/mm ² / 375 HB	1.7225	42CrMo4	1.3505	100Cr6
	High-alloy steel and high-alloy tool steel	P.3.1	Annealed	680 N/mm ² / 200 HB	1.4021	X20Cr13	1.4034	X46Cr13
		P.3.2	Hardened and tempered	1100 N/mm ² / 300 HB	1.2343	X38CrMoV5-1	1.4034	X46Cr13
		P.3.3	Hardened and tempered	1300 N/mm ² / 400 HB	1.2343	X38CrMoV5-1	1.4034	X46Cr13
	Stainless steel	P.4.1	Ferritic / martensitic Annealed	680 N/mm ² / 200 HB	1.4016	X6Cr17	1.2316	X36CrMo16
		P.4.2	Martensitic Tempered	1010 N/mm ² / 300 HB	1.4112	X90CrMoV18	1.2316	X36CrMo16
M	Stainless steel	M.1.1	Austenitic / austenitic-ferritic Quenched	610 N/mm ² / 180 HB	1.4301	X5CrNi18-10	1.4571	X6CrNiMoTi17-12-2
		M.2.1	Austenitic Tempered	300 HB	1.4841	X15CrNiSi25-21	1.4539	X1NiCrMoCu25-20-5
		M.3.1	Austenitic / ferritic (Duplex)	780 N/mm ² / 230 HB	1.4462	X2CrNiMoN22-5-3	1.4501	X2CrNiMoCuWN25-7-4
K	Grey cast iron	K.1.1	Pearlitic / ferritic	350 N/mm ² / 180 HB	0.6010	GG-10	0.6025	GG-25
		K.1.2	Pearlitic (martensitic)	500 N/mm ² / 260 HB	0.6030	GG-30	0.6045	GG-45
	Spherulitic graphite cast iron	K.2.1	Ferritic	540 N/mm ² / 160 HB	0.7040	GGG-40	0.7060	GGG-60
		K.2.2	Pearlitic	845 N/mm ² / 250 HB	0.7070	GGG-70	0.7080	GGG-80
	Malleable iron	K.3.1	Ferritic	440 N/mm ² / 130 HB	0.8035	GTW-35-04	0.8045	GTW-45
		K.3.2	Pearlitic	780 N/mm ² / 230 HB	0.8165	GTS-65-02	0.8170	GTS-70-02
N	Aluminium wrought alloy	N.1.1	Non-hardenable	60 HB	3.0255	Al99,5	3.3315	AlMg1
		N.1.2	Hardenable Age-hardened	340 N/mm ² / 100 HB	3.1355	AlCuMg2	3.2315	AlMgSi1
	Cast aluminium alloy	N.2.1	≤ 12 % Si, non-hardenable	250 N/mm ² / 75 HB	3.2581	G-AlSi12	3.2163	G-AlSi9Cu3
		N.2.2	≤ 12 % Si, hardenable Age-hardened	300 N/mm ² / 90 HB	3.2134	G-AlSi5Cu1Mg	3.2373	G-AlSi9Mg
		N.2.3	> 12 % Si, non-hardenable	440 N/mm ² / 130 HB		G-AlSi17Cu4Mg		G-AlSi18CuNiMg
	Copper and copper alloys (bronze/brass)	N.3.1	Free-machining alloys, PB > 1 %	375 N/mm ² / 110 HB	2.0380	CuZn39Pb2 (Ms58)	2.0410	CuZn44Pb2
		N.3.2	CuZn, CuSnZn	300 N/mm ² / 90 HB	2.0331	CuZn15	2.4070	CuZn28Sn1As
		N.3.3	CuSn, lead-free copper and electrolytic copper	340 N/mm ² / 100 HB	2.0060	E-Cu57	2.0590	CuZn40Fe
	Magnesium alloys	N.4.1	Magnesium and magnesium alloys	70 HB	3.5612	MgAl6Zn	3.5312	MgAl3Zn
	S	Heat-resistant alloys	S.1.1	Fe - basis Annealed	680 N/mm ² / 200 HB	1.4864	X12NiCrSi 36-16	1.4865
S.1.2			Fe - basis Age-hardened	950 N/mm ² / 280 HB	1.4980	X6NiCrTiMoVB25-15-2	1.4876	X10NiCrAlTi32-20
S.2.1			Ni or Co basis Annealed	840 N/mm ² / 250 HB	2.4631	NiCr20TiAl (Nimonic80A)	3.4856	NiCr22Mo9Nb
S.2.2			Ni or Co basis Age-hardened	1180 N/mm ² / 350 HB	2.4668	NiCr19Nb5Mo3 (Inconel 718)	2.4955	NiFe25Cr20NbTi
S.2.3			Ni or Co basis Cast	1080 N/mm ² / 320 HB	2.4765	CoCr20W15Ni	1.3401	G-X120Mn12
Titanium alloys		S.3.1	Pure titanium	400 N/mm ²	3.7025	Ti99,8	3.7034	Ti99,7
		S.3.2	Alpha + beta alloys Age-hardened	1050 N/mm ² / 320 HB	3.7165	TiAl6V4	Ti-6246	Ti-6Al-2Sn-4Zr-6Mo
		S.3.3	Beta alloys	1400 N/mm ² / 410 HB	Ti555.3	Ti-5Al-5V-5Mo-3Cr	R56410	Ti-10V-2Fe-3Al
H	Hardened steel	H.1.1	Hardened and tempered	46–55 HRC				
		H.1.2	Hardened and tempered	56–60 HRC				
		H.1.3	Hardened and tempered	61–65 HRC				
		H.1.4	Hardened and tempered	66–70 HRC				
	Chilled iron	H.2.1	Cast	400 HB				
Hardened cast iron	H.3.1	Hardened and tempered	55 HRC					
O	Non-metal materials	O.1.1	Plastics, duroplastic	≤ 150 N/mm ²				
		O.1.2	Plastics, thermoplastic	≤ 100 N/mm ²				
		O.2.1	Aramid fibre-reinforced	≤ 1000 N/mm ²				
		O.2.2	Glass/carbon-fibre reinforced	≤ 1000 N/mm ²				
		O.3.1	Graphite					

* Tensile strength

Cutting data standard values – WTX – Ti

Index	10 786 ..., 10 787 ...											
	3xD / 5xD											
	with through coolant v _c (m/min)	> Ø 2,5-3	> Ø 3-4	> Ø 4-5	> Ø 5-6	> Ø 6-8	> Ø 8-10	> Ø 10-12	> Ø 12-14	> Ø 14-16	> Ø 16-18	> Ø 18-20
	f (mm/rev)											
P.1.1												
P.1.2	130	0,08	0,10	0,13	0,15	0,18	0,20	0,23	0,26	0,30	0,34	0,38
P.1.3	130	0,08	0,10	0,13	0,15	0,18	0,20	0,23	0,26	0,30	0,34	0,38
P.1.4	115	0,08	0,10	0,13	0,15	0,18	0,20	0,23	0,26	0,30	0,34	0,38
P.1.5	115	0,08	0,10	0,13	0,15	0,18	0,20	0,23	0,26	0,30	0,34	0,38
P.2.1												
P.2.2												
P.2.3	115	0,08	0,10	0,13	0,15	0,18	0,20	0,23	0,26	0,30	0,34	0,38
P.2.4	90	0,08	0,10	0,13	0,15	0,18	0,20	0,23	0,26	0,30	0,34	0,38
P.3.1												
P.3.2												
P.3.3	55	0,08	0,10	0,13	0,15	0,18	0,20	0,23	0,26	0,30	0,34	0,38
P.4.1	75	0,05	0,06	0,08	0,10	0,12	0,14	0,15	0,18	0,20	0,23	0,25
P.4.2	65	0,05	0,06	0,08	0,10	0,12	0,14	0,15	0,18	0,20	0,23	0,25
M.1.1	70	0,05	0,06	0,08	0,10	0,12	0,14	0,15	0,18	0,20	0,23	0,25
M.2.1	70	0,05	0,06	0,08	0,10	0,12	0,14	0,15	0,18	0,20	0,23	0,25
M.3.1	70	0,05	0,06	0,08	0,10	0,12	0,14	0,15	0,18	0,20	0,23	0,25
K.1.1												
K.1.2												
K.2.1												
K.2.2												
K.3.1												
K.3.2												
N.1.1												
N.1.2												
N.2.1												
N.2.2												
N.2.3												
N.3.1												
N.3.2												
N.3.3												
N.4.1												
S.1.1	45	0,02	0,04	0,05	0,07	0,09	0,11	0,13	0,16	0,18	0,20	0,22
S.1.2	45	0,02	0,04	0,05	0,07	0,09	0,11	0,13	0,16	0,18	0,20	0,22
S.2.1	40	0,02	0,04	0,05	0,07	0,09	0,11	0,13	0,16	0,18	0,20	0,22
S.2.2	40	0,02	0,04	0,05	0,07	0,09	0,11	0,13	0,16	0,18	0,20	0,22
S.2.3	40	0,02	0,04	0,05	0,07	0,09	0,11	0,13	0,16	0,18	0,20	0,22
S.3.1	55	0,02	0,04	0,05	0,07	0,09	0,11	0,13	0,16	0,18	0,20	0,22
S.3.2	45	0,02	0,04	0,05	0,07	0,09	0,11	0,13	0,16	0,18	0,20	0,22
S.3.3												
H.1.1												
H.1.2												
H.1.3												
H.1.4												
H.2.1												
H.3.1												
O.1.1												
O.1.2												
O.2.1												
O.2.2												
O.3.1												



The cutting data depends extremely on the external conditions, the material and machine type.
The indicated values are possible values which have to be increased or reduced according to the application conditions.

Cutting data standard values – WTX – Speed UNI

Index	10 781 ...						10 771 ...					
	with through coolant v _c (m/min)	3xD					with through coolant v _c (m/min)	5xD				
		Ø 3–5	Ø 5–8	Ø 8–12	Ø 12–16	Ø 16–20		Ø 3–5	Ø 5–8	Ø 8–12	Ø 12–16	Ø 16–20
		f (mm/rev)						f (mm/rev)				
P.1.1	185	0,17	0,24	0,33	0,40	0,45	185	0,17	0,24	0,33	0,40	0,45
P.1.2	180	0,16	0,23	0,31	0,38	0,43	180	0,16	0,23	0,31	0,38	0,43
P.1.3	170	0,16	0,22	0,30	0,36	0,41	170	0,16	0,22	0,30	0,36	0,41
P.1.4	160	0,15	0,21	0,28	0,35	0,39	160	0,15	0,21	0,28	0,35	0,39
P.1.5	155	0,14	0,20	0,27	0,33	0,37	155	0,14	0,20	0,27	0,33	0,37
P.2.1	185	0,20	0,29	0,39	0,47	0,53	185	0,20	0,29	0,39	0,47	0,53
P.2.2	170	0,18	0,26	0,35	0,43	0,49	170	0,18	0,26	0,35	0,43	0,49
P.2.3	155	0,17	0,24	0,32	0,39	0,44	155	0,17	0,24	0,32	0,39	0,44
P.2.4	120	0,16	0,21	0,28	0,34	0,38	120	0,16	0,21	0,28	0,34	0,38
P.3.1	130	0,16	0,23	0,32	0,39	0,44	130	0,16	0,23	0,32	0,39	0,44
P.3.2	100	0,14	0,20	0,26	0,32	0,36	100	0,14	0,20	0,26	0,32	0,36
P.3.3	100	0,12	0,16	0,20	0,25	0,28	100	0,12	0,16	0,20	0,25	0,28
P.4.1	100	0,11	0,16	0,21	0,25	0,29	100	0,11	0,16	0,21	0,25	0,29
P.4.2	100	0,11	0,16	0,21	0,25	0,29	100	0,11	0,16	0,21	0,25	0,29
M.1.1	65	0,08	0,12	0,16	0,19	0,22	65	0,08	0,12	0,16	0,19	0,22
M.2.1	60	0,07	0,10	0,14	0,17	0,19	60	0,07	0,10	0,14	0,17	0,19
M.3.1	60	0,07	0,10	0,14	0,17	0,19	60	0,07	0,10	0,14	0,17	0,19
K.1.1	150	0,18	0,28	0,40	0,49	0,56	150	0,18	0,28	0,40	0,49	0,56
K.1.2	125	0,16	0,24	0,32	0,39	0,45	125	0,16	0,24	0,32	0,39	0,45
K.2.1	200	0,18	0,27	0,37	0,46	0,52	200	0,18	0,27	0,37	0,46	0,52
K.2.2	125	0,16	0,24	0,32	0,39	0,45	125	0,16	0,24	0,32	0,39	0,45
K.3.1	115	0,18	0,25	0,34	0,42	0,48	115	0,18	0,25	0,34	0,42	0,48
K.3.2	100	0,15	0,21	0,28	0,34	0,38	100	0,15	0,21	0,28	0,34	0,38
N.1.1												
N.1.2												
N.2.1												
N.2.2												
N.2.3												
N.3.1												
N.3.2												
N.3.3												
N.4.1												
S.1.1												
S.1.2												
S.2.1												
S.2.2												
S.2.3												
S.3.1												
S.3.2												
S.3.3												
H.1.1												
H.1.2												
H.1.3												
H.1.4												
H.2.1												
H.3.1												
O.1.1												
O.1.2												
O.2.1												
O.2.2												
O.3.1												



The cutting data depends extremely on the external conditions, the material and machine type.
The indicated values are possible values which have to be increased or reduced according to the application conditions.

Index	10 782 ...							
	with through coolant v_c (m/min)	8xD						
		Ø 3-5	Ø 5-8	Ø 8-12	Ø 12-16	Ø 16-20		
		f (mm/rev)						
P.1.1	185	0,17	0,24	0,33	0,40	0,45		
P.1.2	180	0,16	0,23	0,31	0,38	0,43		
P.1.3	170	0,16	0,22	0,30	0,36	0,41		
P.1.4	160	0,15	0,21	0,28	0,35	0,39		
P.1.5	155	0,14	0,20	0,27	0,33	0,37		
P.2.1	185	0,20	0,29	0,39	0,47	0,53		
P.2.2	170	0,18	0,26	0,35	0,43	0,49		
P.2.3	155	0,17	0,24	0,32	0,39	0,44		
P.2.4	120	0,16	0,21	0,28	0,34	0,38		
P.3.1	130	0,16	0,23	0,32	0,39	0,44		
P.3.2	100	0,14	0,20	0,26	0,32	0,36		
P.3.3	100	0,12	0,16	0,20	0,25	0,28		
P.4.1	100	0,11	0,16	0,21	0,25	0,29		
P.4.2	100	0,11	0,16	0,21	0,25	0,29		
M.1.1	65	0,08	0,12	0,16	0,19	0,22		
M.2.1	60	0,07	0,10	0,14	0,17	0,19		
M.3.1	60	0,07	0,10	0,14	0,17	0,19		
K.1.1	150	0,18	0,28	0,40	0,49	0,56		
K.1.2	125	0,16	0,24	0,32	0,39	0,45		
K.2.1	200	0,18	0,27	0,37	0,46	0,52		
K.2.2	125	0,16	0,24	0,32	0,39	0,45		
K.3.1	115	0,18	0,25	0,34	0,42	0,48		
K.3.2	100	0,15	0,21	0,28	0,34	0,38		
N.1.1								
N.1.2								
N.2.1								
N.2.2								
N.2.3								
N.3.1								
N.3.2								
N.3.3								
N.4.1								
S.1.1								
S.1.2								
S.2.1								
S.2.2								
S.2.3								
S.3.1								
S.3.2								
S.3.3								
H.1.1								
H.1.2								
H.1.3								
H.1.4								
H.2.1								
H.3.1								
O.1.1								
O.1.2								
O.2.1								
O.2.2								
O.3.1								

Cutting data standard values – WTX – Feed UNI

Index	10 789 ...								
	with through coolant v_c (m/min)	5xD							
		\varnothing 4–6	\varnothing 6–7	\varnothing 7–8	\varnothing 8–10	\varnothing 10–12	\varnothing 12–15	\varnothing 15–17	\varnothing 17–20
f (mm/rev)									
P.1.1	125	0,28	0,34	0,37	0,42	0,48	0,54	0,59	0,63
P.1.2	120	0,27	0,32	0,35	0,40	0,46	0,52	0,56	0,60
P.1.3	115	0,25	0,31	0,34	0,38	0,44	0,49	0,54	0,57
P.1.4	110	0,24	0,29	0,32	0,36	0,41	0,47	0,51	0,54
P.1.5	105	0,23	0,27	0,30	0,34	0,39	0,44	0,48	0,52
P.2.1	125	0,33	0,40	0,44	0,50	0,57	0,64	0,70	0,75
P.2.2	115	0,30	0,36	0,40	0,45	0,51	0,58	0,63	0,68
P.2.3	105	0,27	0,32	0,36	0,41	0,46	0,52	0,57	0,61
P.2.4	80	0,25	0,29	0,32	0,36	0,41	0,46	0,50	0,54
P.3.1	85	0,27	0,32	0,36	0,41	0,46	0,52	0,57	0,61
P.3.2	70	0,23	0,27	0,30	0,33	0,38	0,43	0,47	0,50
P.3.3	70	0,18	0,22	0,24	0,26	0,30	0,33	0,36	0,38
P.4.1	70	0,18	0,21	0,24	0,27	0,30	0,34	0,38	0,40
P.4.2	70	0,18	0,21	0,24	0,27	0,30	0,34	0,38	0,40
M.1.1	55	0,13	0,16	0,18	0,20	0,23	0,26	0,28	0,30
M.2.1	50	0,11	0,14	0,15	0,17	0,20	0,22	0,24	0,26
M.3.1	50	0,11	0,14	0,15	0,17	0,20	0,22	0,24	0,26
K.1.1	140	0,38	0,47	0,53	0,61	0,70	0,80	0,89	0,95
K.1.2	115	0,32	0,39	0,44	0,50	0,57	0,64	0,70	0,75
K.2.1	185	0,37	0,45	0,50	0,57	0,66	0,75	0,82	0,88
K.2.2	115	0,32	0,39	0,44	0,50	0,57	0,64	0,70	0,75
K.3.1	105	0,35	0,42	0,47	0,53	0,61	0,69	0,76	0,81
K.3.2	90	0,29	0,35	0,38	0,43	0,49	0,55	0,60	0,64
N.1.1	380	0,28	0,34	0,37	0,42	0,48	0,54	0,59	0,63
N.1.2	345	0,25	0,31	0,34	0,38	0,44	0,49	0,54	0,57
N.2.1	290	0,32	0,39	0,44	0,50	0,57	0,64	0,70	0,75
N.2.2	255	0,32	0,39	0,44	0,50	0,57	0,64	0,70	0,75
N.2.3	205	0,32	0,39	0,44	0,50	0,57	0,64	0,70	0,75
N.3.1	230	0,38	0,47	0,53	0,61	0,70	0,80	0,89	0,95
N.3.2	140	0,24	0,29	0,33	0,37	0,43	0,48	0,53	0,57
N.3.3									
N.4.1									
S.1.1									
S.1.2									
S.2.1									
S.2.2									
S.2.3									
S.3.1									
S.3.2									
S.3.3									
H.1.1									
H.1.2									
H.1.3									
H.1.4									
H.2.1									
H.3.1									
O.1.1									
O.1.2									
O.2.1									
O.2.2									
O.3.1									



The cutting data depends extremely on the external conditions, the material and machine type.
The indicated values are possible values which have to be increased or reduced according to the application conditions.

Index	10 794 ..., 10 796 ...									
	8xD / 12xD									
	with through coolant v _c (m/min)	Ø 4-6	Ø 6-7	Ø 7-8	Ø 8-10	Ø 10-12	Ø 12-15	Ø 15-17	Ø 17-20	
	f (mm/rev)									
P.1.1	125	0,28	0,34	0,37	0,42	0,48	0,54	0,59	0,63	
P.1.2	120	0,27	0,32	0,35	0,40	0,46	0,52	0,56	0,60	
P.1.3	115	0,25	0,31	0,34	0,38	0,44	0,49	0,54	0,57	
P.1.4	110	0,24	0,29	0,32	0,36	0,41	0,47	0,51	0,54	
P.1.5	105	0,23	0,27	0,30	0,34	0,39	0,44	0,48	0,52	
P.2.1	125	0,33	0,40	0,44	0,50	0,57	0,64	0,70	0,75	
P.2.2	115	0,30	0,36	0,40	0,45	0,51	0,58	0,63	0,68	
P.2.3	105	0,27	0,32	0,36	0,41	0,46	0,52	0,57	0,61	
P.2.4	80	0,25	0,29	0,32	0,36	0,41	0,46	0,50	0,54	
P.3.1	85	0,27	0,32	0,36	0,41	0,46	0,52	0,57	0,61	
P.3.2	70	0,23	0,27	0,30	0,33	0,38	0,43	0,47	0,50	
P.3.3	70	0,18	0,22	0,24	0,26	0,30	0,33	0,36	0,38	
P.4.1	70	0,18	0,21	0,24	0,27	0,30	0,34	0,38	0,40	
P.4.2	70	0,18	0,21	0,24	0,27	0,30	0,34	0,38	0,40	
M.1.1	55	0,13	0,16	0,18	0,20	0,23	0,26	0,28	0,30	
M.2.1	50	0,11	0,14	0,15	0,17	0,20	0,22	0,24	0,26	
M.3.1	50	0,11	0,14	0,15	0,17	0,20	0,22	0,24	0,26	
K.1.1	140	0,38	0,47	0,53	0,61	0,70	0,80	0,89	0,95	
K.1.2	115	0,32	0,39	0,44	0,50	0,57	0,64	0,70	0,75	
K.2.1	185	0,37	0,45	0,50	0,57	0,66	0,75	0,82	0,88	
K.2.2	115	0,32	0,39	0,44	0,50	0,57	0,64	0,70	0,75	
K.3.1	105	0,35	0,42	0,47	0,53	0,61	0,69	0,76	0,81	
K.3.2	90	0,29	0,35	0,38	0,43	0,49	0,55	0,60	0,64	
N.1.1	380	0,28	0,34	0,37	0,42	0,48	0,54	0,59	0,63	
N.1.2	345	0,25	0,31	0,34	0,38	0,44	0,49	0,54	0,57	
N.2.1	290	0,32	0,39	0,44	0,50	0,57	0,64	0,70	0,75	
N.2.2	255	0,32	0,39	0,44	0,50	0,57	0,64	0,70	0,75	
N.2.3	205	0,32	0,39	0,44	0,50	0,57	0,64	0,70	0,75	
N.3.1	230	0,38	0,47	0,53	0,61	0,70	0,80	0,89	0,95	
N.3.2	140	0,24	0,29	0,33	0,37	0,43	0,48	0,53	0,57	
N.3.3										
N.4.1										
S.1.1										
S.1.2										
S.2.1										
S.2.2										
S.2.3										
S.3.1										
S.3.2										
S.3.3										
H.1.1										
H.1.2										
H.1.3										
H.1.4										
H.2.1										
H.3.1										
O.1.1										
O.1.2										
O.2.1										
O.2.2										
O.3.1										

Cutting data standard values – WTX – UNI

Index	11 776 ..., 11 777 ..., 11 778 ..., 11 779 ..., 11 780 ..., 11 781 ...							
			3xD					
	without through coolant	with through coolant	Ø 3–5	Ø 5–8	Ø 8–12	Ø 12–16	Ø 16–20	Ø 20–25
	v _c (m/min)		f (mm/rev)					
P.1.1	110	120	0,13	0,18	0,25	0,30	0,34	0,37
P.1.2	105	115	0,12	0,18	0,24	0,29	0,33	0,36
P.1.3	100	110	0,12	0,17	0,23	0,28	0,31	0,34
P.1.4	95	105	0,11	0,16	0,21	0,26	0,30	0,32
P.1.5	90	100	0,11	0,15	0,20	0,25	0,28	0,30
P.2.1	105	120	0,15	0,22	0,29	0,36	0,41	0,44
P.2.2	95	110	0,14	0,20	0,27	0,33	0,37	0,40
P.2.3	85	100	0,13	0,18	0,24	0,29	0,33	0,36
P.2.4	65	75	0,12	0,16	0,21	0,26	0,29	0,32
P.3.1	70	85	0,12	0,18	0,24	0,29	0,33	0,36
P.3.2	60	65	0,11	0,15	0,20	0,24	0,27	0,29
P.3.3	50	65	0,09	0,12	0,15	0,19	0,21	0,23
P.4.1	50	65	0,08	0,12	0,16	0,19	0,22	0,24
P.4.2	50	65	0,08	0,12	0,16	0,19	0,22	0,24
M.1.1								
M.2.1								
M.3.1								
K.1.1	85	120	0,17	0,26	0,36	0,45	0,52	0,56
K.1.2	75	100	0,15	0,22	0,29	0,36	0,41	0,45
K.2.1	100	160	0,17	0,25	0,34	0,42	0,48	0,52
K.2.2	75	100	0,15	0,22	0,29	0,36	0,41	0,45
K.3.1	80	90	0,16	0,23	0,32	0,39	0,44	0,48
K.3.2	70	80	0,14	0,19	0,25	0,31	0,35	0,38
N.1.1								
N.1.2								
N.2.1								
N.2.2								
N.2.3								
N.3.1								
N.3.2								
N.3.3								
N.4.1								
S.1.1								
S.1.2								
S.2.1								
S.2.2								
S.2.3								
S.3.1								
S.3.2								
S.3.3								
H.1.1	25	25	0,06	0,08	0,11	0,14	0,15	0,17
H.1.2								
H.1.3								
H.1.4								
H.2.1	35	35	0,08	0,11	0,14	0,18	0,20	0,22
H.3.1								
O.1.1								
O.1.2								
O.2.1								
O.2.2								
O.3.1								



The cutting data depends extremely on the external conditions, the material and machine type.
The indicated values are possible values which have to be increased or reduced according to the application conditions.

Index	11 782 ..., 11 783 ..., 11 784 ..., 11 785 ..., 11 786 ..., 11 787 ...									11 788 ..., 11 789 ..., 11 790 ...						
			5xD									8xD				
	without coolant	with coolant	Ø 3-5	Ø 5-8	Ø 8-12	Ø 12-16	Ø 16-20	Ø 20-25	with coolant	Ø 3-5	Ø 5-8	Ø 8-12	Ø 12-16	Ø 16-20		
	v _c (m/min)		f (mm/rev)							v _c (m/min)		f (mm/rev)				
P.1.1	110	120	0,13	0,18	0,25	0,30	0,34	0,37	110	0,13	0,18	0,25	0,30	0,34		
P.1.2	105	115	0,12	0,18	0,24	0,29	0,33	0,36	105	0,12	0,18	0,24	0,29	0,33		
P.1.3	100	110	0,12	0,17	0,23	0,28	0,31	0,34	100	0,12	0,17	0,23	0,28	0,31		
P.1.4	95	105	0,11	0,16	0,21	0,26	0,30	0,32	95	0,11	0,16	0,21	0,26	0,30		
P.1.5	90	100	0,11	0,15	0,20	0,25	0,28	0,30	90	0,11	0,15	0,20	0,25	0,28		
P.2.1	105	120	0,15	0,22	0,29	0,36	0,41	0,44	105	0,15	0,22	0,29	0,36	0,41		
P.2.2	95	110	0,14	0,20	0,27	0,33	0,37	0,40	95	0,14	0,20	0,27	0,33	0,37		
P.2.3	85	100	0,13	0,18	0,24	0,29	0,33	0,36	85	0,13	0,18	0,24	0,29	0,33		
P.2.4	65	75	0,12	0,16	0,21	0,26	0,29	0,32	65	0,12	0,16	0,21	0,26	0,29		
P.3.1	70	85	0,12	0,18	0,24	0,29	0,33	0,36	70	0,12	0,18	0,24	0,29	0,33		
P.3.2	60	65	0,11	0,15	0,20	0,24	0,27	0,29	60	0,11	0,15	0,20	0,24	0,27		
P.3.3	50	65	0,09	0,12	0,15	0,19	0,21	0,23	50	0,09	0,12	0,15	0,19	0,21		
P.4.1	50	65	0,08	0,12	0,16	0,19	0,22	0,24	50	0,08	0,12	0,16	0,19	0,22		
P.4.2	50	65	0,08	0,12	0,16	0,19	0,22	0,24	50	0,08	0,12	0,16	0,19	0,22		
M.1.1																
M.2.1																
M.3.1																
K.1.1	85	120	0,17	0,26	0,36	0,45	0,52	0,56	85	0,17	0,26	0,36	0,45	0,52		
K.1.2	75	100	0,15	0,22	0,29	0,36	0,41	0,45	75	0,15	0,22	0,29	0,36	0,41		
K.2.1	100	160	0,17	0,25	0,34	0,42	0,48	0,52	100	0,17	0,25	0,34	0,42	0,48		
K.2.2	75	100	0,15	0,22	0,29	0,36	0,41	0,45	75	0,15	0,22	0,29	0,36	0,41		
K.3.1	80	90	0,16	0,23	0,32	0,39	0,44	0,48	80	0,16	0,23	0,32	0,39	0,44		
K.3.2	70	80	0,14	0,19	0,25	0,31	0,35	0,38	70	0,14	0,19	0,25	0,31	0,35		
N.1.1																
N.1.2																
N.2.1																
N.2.2																
N.2.3																
N.3.1																
N.3.2																
N.3.3																
N.4.1																
S.1.1																
S.1.2																
S.2.1																
S.2.2																
S.2.3																
S.3.1																
S.3.2																
S.3.3																
H.1.1	25	25	0,06	0,08	0,11	0,14	0,15	0,17	25	0,06	0,08	0,11	0,14	0,15		
H.1.2																
H.1.3																
H.1.4																
H.2.1	35	35	0,08	0,11	0,14	0,18	0,20	0,22	35	0,08	0,11	0,14	0,18	0,20		
H.3.1																
O.1.1																
O.1.2																
O.2.1																
O.2.2																
O.3.1																

Cutting data standard values – WTX – VA

Index	10 731 ..., 10 732 ..., 10 733 ..., 10 734 ...							10 740 ..., 10 741 ..., 10 745 ..., 10 746 ...						
			3xD							5xD				
	without through coolant	with through coolant	Ø 2-5	Ø 5-8	Ø 8-12	Ø 12-16	Ø 16-20	without through coolant	with through coolant	Ø 2-5	Ø 5-8	Ø 8-12	Ø 12-16	Ø 16-20
	v _c (m/min)		f (mm/rev)					v _c (m/min)		f (mm/rev)				
P.1.1	100	110	0,09	0,13	0,18	0,22	0,25	100	110	0,09	0,13	0,18	0,22	0,25
P.1.2	95	105	0,09	0,13	0,17	0,21	0,24	95	105	0,09	0,13	0,17	0,21	0,24
P.1.3	90	100	0,09	0,12	0,16	0,20	0,23	90	100	0,09	0,12	0,16	0,20	0,23
P.1.4	85	95	0,08	0,12	0,16	0,19	0,22	85	95	0,08	0,12	0,16	0,19	0,22
P.1.5	80	90	0,08	0,11	0,15	0,18	0,20	80	90	0,08	0,11	0,15	0,18	0,20
P.2.1	95	110	0,11	0,16	0,21	0,26	0,29	95	110	0,11	0,16	0,21	0,26	0,29
P.2.2	85	100	0,10	0,14	0,19	0,24	0,27	85	100	0,10	0,14	0,19	0,24	0,27
P.2.3	75	90	0,09	0,13	0,17	0,21	0,24	75	90	0,09	0,13	0,17	0,21	0,24
P.2.4	60	70	0,09	0,12	0,16	0,19	0,21	60	70	0,09	0,12	0,16	0,19	0,21
P.3.1	65	75	0,09	0,13	0,17	0,21	0,24	65	75	0,09	0,13	0,17	0,21	0,24
P.3.2	55	60	0,08	0,11	0,14	0,17	0,20	55	60	0,08	0,11	0,14	0,17	0,20
P.3.3	45	60	0,06	0,09	0,11	0,14	0,15	45	60	0,06	0,09	0,11	0,14	0,15
P.4.1	45	60	0,06	0,09	0,11	0,14	0,16	45	60	0,06	0,09	0,11	0,14	0,16
P.4.2	45	60	0,06	0,09	0,11	0,14	0,16	45	60	0,06	0,09	0,11	0,14	0,16
M.1.1	35	55	0,08	0,11	0,14	0,18	0,20	35	55	0,08	0,11	0,14	0,18	0,20
M.2.1	30	50	0,06	0,09	0,12	0,15	0,17	30	50	0,06	0,09	0,12	0,15	0,17
M.3.1	30	50	0,06	0,09	0,12	0,15	0,17	30	50	0,06	0,09	0,12	0,15	0,17
K.1.1	85	120	0,15	0,24	0,33	0,41	0,47	85	120	0,15	0,24	0,33	0,41	0,47
K.1.2	75	100	0,14	0,20	0,27	0,33	0,37	75	100	0,14	0,20	0,27	0,33	0,37
K.2.1	100	160	0,15	0,22	0,31	0,38	0,43	100	160	0,15	0,22	0,31	0,38	0,43
K.2.2	75	100	0,14	0,20	0,27	0,33	0,37	75	100	0,14	0,20	0,27	0,33	0,37
K.3.1	80	90	0,15	0,21	0,29	0,35	0,40	80	90	0,15	0,21	0,29	0,35	0,40
K.3.2	70	80	0,12	0,17	0,23	0,28	0,32	70	80	0,12	0,17	0,23	0,28	0,32
N.1.1	220	330	0,10	0,16	0,22	0,30	0,33	220	330	0,10	0,16	0,22	0,30	0,33
N.1.2	200	300	0,09	0,12	0,20	0,25	0,30	200	300	0,09	0,12	0,20	0,25	0,30
N.2.1	180	250	0,11	0,15	0,26	0,33	0,39	180	250	0,11	0,15	0,26	0,33	0,39
N.2.2	150	220	0,11	0,15	0,26	0,33	0,39	150	220	0,11	0,15	0,26	0,33	0,39
N.2.3	120	180	0,11	0,15	0,26	0,33	0,39	120	180	0,11	0,15	0,26	0,33	0,39
N.3.1	160	200	0,15	0,24	0,33	0,41	0,47	160	200	0,15	0,24	0,33	0,41	0,47
N.3.2	90	120	0,14	0,20	0,27	0,33	0,37	90	120	0,14	0,20	0,27	0,33	0,37
N.3.3	100	140	0,12	0,15	0,21	0,25	0,28	100	140	0,12	0,15	0,21	0,25	0,28
N.4.1														
S.1.1	20	30	0,06	0,09	0,11	0,14	0,16	20	30	0,06	0,09	0,11	0,14	0,16
S.1.2	15	20	0,04	0,06	0,08	0,10	0,11	15	20	0,04	0,06	0,08	0,10	0,11
S.2.1	15	20	0,04	0,06	0,08	0,10	0,11	15	20	0,04	0,06	0,08	0,10	0,11
S.2.2	10	15	0,05	0,08	0,10	0,13	0,14	10	15	0,05	0,08	0,10	0,13	0,14
S.2.3	10	15	0,04	0,06	0,08	0,10	0,11	10	15	0,04	0,06	0,08	0,10	0,11
S.3.1														
S.3.2	20	30	0,06	0,09	0,12	0,15	0,17	20	30	0,06	0,09	0,12	0,15	0,17
S.3.3	15	25	0,05	0,08	0,10	0,13	0,14	15	25	0,05	0,08	0,10	0,13	0,14
H.1.1														
H.1.2														
H.1.3														
H.1.4														
H.2.1														
H.3.1														
O.1.1														
O.1.2														
O.2.1														
O.2.2														
O.3.1														

 The cutting data depends extremely on the external conditions, the material and machine type.
The indicated values are possible values which have to be increased or reduced according to the application conditions.

Index	10 770 ...					
	with through coolant v _c (m/min)	8xD				
		Ø 3–5	Ø 5–8	Ø 8–12	Ø 12–16	Ø 16–20
		f (mm/rev)				
P.1.1	110	0,09	0,13	0,18	0,22	0,25
P.1.2	105	0,09	0,13	0,17	0,21	0,24
P.1.3	100	0,09	0,12	0,16	0,20	0,23
P.1.4	95	0,08	0,12	0,16	0,19	0,22
P.1.5	90	0,08	0,11	0,15	0,18	0,20
P.2.1	110	0,11	0,16	0,21	0,26	0,29
P.2.2	100	0,10	0,14	0,19	0,24	0,27
P.2.3	90	0,09	0,13	0,17	0,21	0,24
P.2.4	70	0,09	0,12	0,16	0,19	0,21
P.3.1	75	0,09	0,13	0,17	0,21	0,24
P.3.2	60	0,08	0,11	0,14	0,17	0,20
P.3.3	60	0,06	0,09	0,11	0,14	0,15
P.4.1	60	0,06	0,09	0,11	0,14	0,16
P.4.2	60	0,06	0,09	0,11	0,14	0,16
M.1.1	55	0,08	0,11	0,14	0,18	0,20
M.2.1	50	0,06	0,09	0,12	0,15	0,17
M.3.1	50	0,06	0,09	0,12	0,15	0,17
K.1.1	120	0,15	0,24	0,33	0,41	0,47
K.1.2	100	0,14	0,20	0,27	0,33	0,37
K.2.1	160	0,15	0,22	0,31	0,38	0,43
K.2.2	100	0,14	0,20	0,27	0,33	0,37
K.3.1	90	0,15	0,21	0,29	0,35	0,40
K.3.2	80	0,12	0,17	0,23	0,28	0,32
N.1.1	330	0,10	0,16	0,22	0,30	0,33
N.1.2	300	0,09	0,12	0,20	0,25	0,30
N.2.1	250	0,11	0,15	0,26	0,33	0,39
N.2.2	220	0,11	0,15	0,26	0,33	0,39
N.2.3	180	0,11	0,15	0,26	0,33	0,39
N.3.1	200	0,15	0,24	0,33	0,41	0,47
N.3.2	120	0,14	0,20	0,27	0,33	0,37
N.3.3	140	0,12	0,15	0,21	0,25	0,28
N.4.1						
S.1.1	30	0,06	0,09	0,11	0,14	0,16
S.1.2	20	0,04	0,06	0,08	0,10	0,11
S.2.1	20	0,04	0,06	0,08	0,10	0,11
S.2.2	15	0,05	0,08	0,10	0,13	0,14
S.2.3	15	0,04	0,06	0,08	0,10	0,11
S.3.1						
S.3.2	30	0,06	0,09	0,12	0,15	0,17
S.3.3	25	0,05	0,08	0,10	0,13	0,14
H.1.1						
H.1.2						
H.1.3						
H.1.4						
H.2.1						
H.3.1						
O.1.1						
O.1.2						
O.2.1						
O.2.2						
O.3.1						

Cutting data standard values – WTX – Speed VA

Index	10 773 ...						10 774 ...					
	with through coolant v_c (m/min)	5xD					with through coolant v_c (m/min)	12xD				
		Ø 3–5	Ø 5–8	Ø 8–12	Ø 12–16	Ø 16–20		Ø 3–5	Ø 5–8	Ø 8–12	Ø 12–16	Ø 16–20
		f (mm/rev)						f (mm/rev)				
P.1.1	165	0,12	0,17	0,23	0,28	0,31	110	0,09	0,13	0,18	0,22	0,25
P.1.2	160	0,11	0,16	0,22	0,26	0,30	105	0,09	0,13	0,17	0,21	0,24
P.1.3	150	0,11	0,15	0,20	0,25	0,28	100	0,09	0,12	0,16	0,20	0,23
P.1.4	145	0,10	0,15	0,19	0,24	0,27	95	0,08	0,12	0,16	0,19	0,22
P.1.5	135	0,10	0,14	0,18	0,23	0,26	90	0,08	0,11	0,15	0,18	0,20
P.2.1	165	0,14	0,20	0,27	0,33	0,37	110	0,11	0,16	0,21	0,26	0,29
P.2.2	150	0,13	0,18	0,24	0,30	0,34	100	0,10	0,14	0,19	0,24	0,27
P.2.3	135	0,11	0,16	0,22	0,27	0,30	90	0,09	0,13	0,17	0,21	0,24
P.2.4	105	0,11	0,15	0,19	0,24	0,27	70	0,09	0,12	0,16	0,19	0,21
P.3.1	115	0,11	0,16	0,22	0,27	0,30	75	0,09	0,13	0,17	0,21	0,24
P.3.2	90	0,10	0,13	0,18	0,22	0,25	60	0,08	0,11	0,14	0,17	0,20
P.3.3	90	0,08	0,11	0,14	0,17	0,19	60	0,06	0,09	0,11	0,14	0,15
P.4.1	70	0,08	0,11	0,14	0,18	0,20	60	0,06	0,09	0,11	0,14	0,16
P.4.2	70	0,08	0,11	0,14	0,18	0,20	60	0,06	0,09	0,11	0,14	0,16
M.1.1	80	0,09	0,13	0,18	0,22	0,25	55	0,08	0,11	0,14	0,18	0,20
M.2.1	75	0,08	0,11	0,15	0,19	0,21	50	0,06	0,09	0,12	0,15	0,17
M.3.1	75	0,08	0,11	0,15	0,19	0,21	50	0,06	0,09	0,12	0,15	0,17
K.1.1	150	0,15	0,24	0,33	0,41	0,47	120	0,15	0,24	0,33	0,41	0,47
K.1.2	125	0,14	0,20	0,27	0,33	0,37	100	0,14	0,20	0,27	0,33	0,37
K.2.1	200	0,15	0,22	0,31	0,38	0,43	160	0,15	0,22	0,31	0,38	0,43
K.2.2	125	0,14	0,20	0,27	0,33	0,37	100	0,14	0,20	0,27	0,33	0,37
K.3.1	115	0,15	0,21	0,29	0,35	0,40	90	0,15	0,21	0,29	0,35	0,40
K.3.2	100	0,12	0,17	0,23	0,28	0,32	80	0,12	0,17	0,23	0,28	0,32
N.1.1												
N.1.2												
N.2.1												
N.2.2												
N.2.3												
N.3.1							200	0,15	0,24	0,33	0,41	0,47
N.3.2	145	0,14	0,20	0,27	0,33	0,37	120	0,14	0,20	0,27	0,33	0,37
N.3.3												
N.4.1												
S.1.1	35	0,07	0,10	0,14	0,17	0,19	30	0,06	0,09	0,11	0,14	0,16
S.1.2	25	0,05	0,07	0,10	0,12	0,14	20	0,04	0,06	0,08	0,10	0,11
S.2.1	25	0,05	0,07	0,10	0,12	0,14	20	0,04	0,06	0,08	0,10	0,11
S.2.2	20	0,06	0,09	0,12	0,15	0,17	15	0,05	0,08	0,10	0,13	0,14
S.2.3	20	0,05	0,07	0,10	0,12	0,14	15	0,04	0,06	0,08	0,10	0,11
S.3.1												
S.3.2	35	0,08	0,11	0,15	0,18	0,20	30	0,06	0,09	0,12	0,15	0,17
S.3.3	30	0,06	0,09	0,12	0,15	0,17	25	0,05	0,08	0,10	0,13	0,14
H.1.1												
H.1.2												
H.1.3												
H.1.4												
H.2.1												
H.3.1												
O.1.1												
O.1.2												
O.2.1												
O.2.2												
O.3.1												



The cutting data depends extremely on the external conditions, the material and machine type.
The indicated values are possible values which have to be increased or reduced according to the application conditions.

Cutting data standard values – WTX – H

Index	10 777 ...								
	without through coolant v_c (m/min)	3xD							
		\varnothing 2-3	\varnothing 3-4	\varnothing 4-5	\varnothing 5-6	\varnothing 6-8	\varnothing 8-10	\varnothing 10-12	\varnothing 12-14
		f (mm/rev)							
P.1.1	80	0,05	0,07	0,08	0,10	0,14	0,18	0,21	0,24
P.1.2	70	0,04	0,05	0,07	0,08	0,12	0,15	0,18	0,21
P.1.3	70	0,04	0,05	0,07	0,08	0,12	0,15	0,18	0,21
P.1.4	70	0,04	0,05	0,07	0,08	0,12	0,15	0,18	0,21
P.1.5	80	0,05	0,07	0,08	0,10	0,14	0,18	0,21	0,24
P.2.1	75	0,05	0,07	0,08	0,10	0,14	0,18	0,21	0,24
P.2.2	70	0,05	0,06	0,08	0,09	0,13	0,16	0,19	0,22
P.2.3	70	0,04	0,05	0,07	0,08	0,12	0,15	0,18	0,21
P.2.4	70	0,04	0,05	0,07	0,08	0,12	0,15	0,18	0,21
P.3.1									
P.3.2									
P.3.3									
P.4.1									
P.4.2									
M.1.1									
M.2.1									
M.3.1									
K.1.1	85	0,08	0,10	0,13	0,15	0,19	0,23	0,27	0,34
K.1.2	80	0,08	0,10	0,13	0,15	0,19	0,23	0,27	0,34
K.2.1	85	0,06	0,08	0,10	0,13	0,16	0,18	0,22	0,25
K.2.2	80	0,06	0,08	0,10	0,13	0,16	0,18	0,22	0,25
K.3.1	85	0,06	0,08	0,10	0,13	0,16	0,18	0,22	0,25
K.3.2	80	0,06	0,08	0,10	0,13	0,16	0,18	0,22	0,25
N.1.1									
N.1.2									
N.2.1									
N.2.2									
N.2.3									
N.3.1									
N.3.2									
N.3.3									
N.4.1									
S.1.1									
S.1.2									
S.2.1									
S.2.2									
S.2.3									
S.3.1									
S.3.2									
S.3.3									
H.1.1	30	0,04	0,05	0,05	0,06	0,07	0,08	0,09	0,10
H.1.2	15	0,04	0,05	0,05	0,06	0,07	0,08	0,09	0,10
H.1.3	10	0,03	0,04	0,04	0,05	0,06	0,06	0,07	0,07
H.1.4	10	0,03	0,04	0,04	0,05	0,06	0,06	0,07	0,07
H.2.1									
H.3.1									
O.1.1									
O.1.2									
O.2.1									
O.2.2									
O.3.1									



The cutting data depends extremely on the external conditions, the material and machine type.
The indicated values are possible values which have to be increased or reduced according to the application conditions.

Cutting data standard values – WTX – Quattro 4F

Index	10 735 ...						10 736 ...					
	with through coolant v_c (m/min)	5xD					with through coolant v_c (m/min)	8xD				
		Ø 3–5	Ø 5–8	Ø 8–12	Ø 12–16	Ø 16–20		Ø 3–5	Ø 5–8	Ø 8–12	Ø 12–16	Ø 16–20
		f (mm/rev)						f (mm/rev)				
P.1.1	110	0,12	0,17	0,23	0,28	0,31	110	0,12	0,17	0,23	0,28	0,31
P.1.2	105	0,11	0,16	0,22	0,26	0,30	105	0,11	0,16	0,22	0,26	0,30
P.1.3	100	0,11	0,15	0,20	0,25	0,28	100	0,11	0,15	0,20	0,25	0,28
P.1.4	95	0,10	0,15	0,19	0,24	0,27	95	0,10	0,15	0,19	0,24	0,27
P.1.5	90	0,10	0,14	0,18	0,23	0,26	90	0,10	0,14	0,18	0,23	0,26
P.2.1	110	0,14	0,20	0,27	0,33	0,37	110	0,14	0,20	0,27	0,33	0,37
P.2.2	100	0,13	0,18	0,24	0,30	0,34	100	0,13	0,18	0,24	0,30	0,34
P.2.3	90	0,11	0,16	0,22	0,27	0,30	90	0,11	0,16	0,22	0,27	0,30
P.2.4	70	0,11	0,15	0,19	0,24	0,27	70	0,11	0,15	0,19	0,24	0,27
P.3.1	75	0,11	0,16	0,22	0,27	0,30	75	0,11	0,16	0,22	0,27	0,30
P.3.2	60	0,10	0,13	0,18	0,22	0,25	60	0,10	0,13	0,18	0,22	0,25
P.3.3	60	0,08	0,11	0,14	0,17	0,19	60	0,08	0,11	0,14	0,17	0,19
P.4.1	60	0,08	0,11	0,14	0,18	0,20	60	0,08	0,11	0,14	0,18	0,20
P.4.2	60	0,08	0,11	0,14	0,18	0,20	60	0,08	0,11	0,14	0,18	0,20
M.1.1												
M.2.1												
M.3.1												
K.1.1	120	0,15	0,24	0,33	0,41	0,47	120	0,15	0,24	0,33	0,41	0,47
K.1.2	100	0,14	0,20	0,27	0,33	0,37	100	0,14	0,20	0,27	0,33	0,37
K.2.1	160	0,15	0,22	0,31	0,38	0,43	160	0,15	0,22	0,31	0,38	0,43
K.2.2	100	0,14	0,20	0,27	0,33	0,37	100	0,14	0,20	0,27	0,33	0,37
K.3.1	90	0,15	0,21	0,29	0,35	0,40	90	0,15	0,21	0,29	0,35	0,40
K.3.2	80	0,12	0,17	0,23	0,28	0,32	80	0,12	0,17	0,23	0,28	0,32
N.1.1												
N.1.2												
N.2.1												
N.2.2												
N.2.3												
N.3.1												
N.3.2												
N.3.3												
N.4.1												
S.1.1												
S.1.2												
S.2.1												
S.2.2												
S.2.3												
S.3.1												
S.3.2												
S.3.3												
H.1.1	25	0,05	0,07	0,09	0,12	0,13	25	0,05	0,07	0,09	0,12	0,13
H.1.2												
H.1.3												
H.1.4												
H.2.1	30	0,06	0,09	0,12	0,15	0,17	30	0,06	0,09	0,12	0,15	0,17
H.3.1												
O.1.1												
O.1.2												
O.2.1												
O.2.2												
O.3.1												



The cutting data depends extremely on the external conditions, the material and machine type.
The indicated values are possible values which have to be increased or reduced according to the application conditions.

Index	10 737 ...						
	with through coolant v _c (m/min)	12xD					Ø 16-20
		Ø 3-5	Ø 5-8	Ø 8-12	Ø 12-16	f (mm/rev)	
P.1.1	110	0,12	0,17	0,23	0,28	0,31	
P.1.2	105	0,11	0,16	0,22	0,26	0,30	
P.1.3	100	0,11	0,15	0,20	0,25	0,28	
P.1.4	95	0,10	0,15	0,19	0,24	0,27	
P.1.5	90	0,10	0,14	0,18	0,23	0,26	
P.2.1	110	0,14	0,20	0,27	0,33	0,37	
P.2.2	100	0,13	0,18	0,24	0,30	0,34	
P.2.3	90	0,11	0,16	0,22	0,27	0,30	
P.2.4	70	0,11	0,15	0,19	0,24	0,27	
P.3.1	75	0,11	0,16	0,22	0,27	0,30	
P.3.2	60	0,10	0,13	0,18	0,22	0,25	
P.3.3	60	0,08	0,11	0,14	0,17	0,19	
P.4.1	60	0,08	0,11	0,14	0,18	0,20	
P.4.2	60	0,08	0,11	0,14	0,18	0,20	
M.1.1							
M.2.1							
M.3.1							
K.1.1	120	0,15	0,24	0,33	0,41	0,47	
K.1.2	100	0,14	0,20	0,27	0,33	0,37	
K.2.1	160	0,15	0,22	0,31	0,38	0,43	
K.2.2	100	0,14	0,20	0,27	0,33	0,37	
K.3.1	90	0,15	0,21	0,29	0,35	0,40	
K.3.2	80	0,12	0,17	0,23	0,28	0,32	
N.1.1							
N.1.2							
N.2.1							
N.2.2							
N.2.3							
N.3.1							
N.3.2							
N.3.3							
N.4.1							
S.1.1							
S.1.2							
S.2.1							
S.2.2							
S.2.3							
S.3.1							
S.3.2							
S.3.3							
H.1.1	25	0,05	0,07	0,09	0,12	0,13	
H.1.2							
H.1.3							
H.1.4							
H.2.1	30	0,06	0,09	0,12	0,15	0,17	
H.3.1							
O.1.1							
O.1.2							
O.2.1							
O.2.2							
O.3.1							

Cutting data standard values – WTX – AL

Index	10 791 ...											
	with through coolant v _c (m/min)	5xD										
		Ø 2-3	Ø 3-4	Ø 4-5	Ø 5-6	Ø 6-8	Ø 8-10	Ø 10-12	Ø 12-14	Ø 14-16	Ø 16-18	Ø 18-20
f (mm/rev)												
P.1.1												
P.1.2												
P.1.3												
P.1.4												
P.1.5												
P.2.1												
P.2.2												
P.2.3												
P.2.4												
P.3.1												
P.3.2												
P.3.3												
P.4.1												
P.4.2												
M.1.1												
M.2.1												
M.3.1												
K.1.1												
K.1.2												
K.2.1												
K.2.2												
K.3.1												
K.3.2												
N.1.1	360	0,15	0,20	0,23	0,25	0,29	0,32	0,35	0,40	0,45	0,50	0,55
N.1.2	400	0,15	0,20	0,23	0,25	0,29	0,32	0,35	0,40	0,45	0,50	0,55
N.2.1	360	0,20	0,23	0,25	0,28	0,32	0,35	0,38	0,45	0,50	0,55	0,60
N.2.2	400	0,20	0,23	0,25	0,28	0,32	0,35	0,38	0,45	0,50	0,55	0,60
N.2.3	350	0,15	0,20	0,23	0,25	0,29	0,32	0,35	0,40	0,45	0,50	0,55
N.3.1	200	0,08	0,11	0,13	0,15	0,19	0,23	0,26	0,30	0,34	0,38	0,42
N.3.2	200	0,08	0,11	0,13	0,15	0,19	0,23	0,26	0,30	0,34	0,38	0,42
N.3.3	160	0,08	0,11	0,13	0,15	0,19	0,23	0,26	0,30	0,34	0,38	0,42
N.4.1												
S.1.1												
S.1.2												
S.2.1												
S.2.2												
S.2.3												
S.3.1												
S.3.2												
S.3.3												
H.1.1												
H.1.2												
H.1.3												
H.1.4												
H.2.1												
H.3.1												
O.1.1												
O.1.2												
O.2.1												
O.2.2												
O.3.1												

 The cutting data depends extremely on the external conditions, the material and machine type.
The indicated values are possible values which have to be increased or reduced according to the application conditions.

Index	10 792 ...											
	with through coolant v _c (m/min)	8xD										
		Ø 3-4	Ø 4-5	Ø 5-6	Ø 6-8	Ø 8-10	Ø 10-12	Ø 12-14	Ø 14-16	Ø 16-18	Ø 18-20	
		f (mm/rev)										
P.1.1												
P.1.2												
P.1.3												
P.1.4												
P.1.5												
P.2.1												
P.2.2												
P.2.3												
P.2.4												
P.3.1												
P.3.2												
P.3.3												
P.4.1												
P.4.2												
M.1.1												
M.2.1												
M.3.1												
K.1.1												
K.1.2												
K.2.1												
K.2.2												
K.3.1												
K.3.2												
N.1.1	320	0,20	0,23	0,25	0,29	0,32	0,35	0,40	0,45	0,50	0,55	0,55
N.1.2	360	0,20	0,23	0,25	0,29	0,32	0,35	0,40	0,45	0,50	0,55	0,55
N.2.1	320	0,23	0,25	0,28	0,32	0,35	0,38	0,45	0,50	0,55	0,60	0,60
N.2.2	360	0,23	0,25	0,28	0,32	0,35	0,38	0,45	0,50	0,55	0,60	0,60
N.2.3	310	0,20	0,23	0,25	0,29	0,32	0,35	0,40	0,45	0,50	0,55	0,55
N.3.1	160	0,11	0,13	0,15	0,19	0,23	0,26	0,30	0,34	0,38	0,42	0,42
N.3.2	160	0,11	0,13	0,15	0,19	0,23	0,26	0,30	0,34	0,38	0,42	0,42
N.3.3	140	0,11	0,13	0,15	0,19	0,23	0,26	0,30	0,34	0,38	0,42	0,42
N.4.1												
S.1.1												
S.1.2												
S.2.1												
S.2.2												
S.2.3												
S.3.1												
S.3.2												
S.3.3												
H.1.1												
H.1.2												
H.1.3												
H.1.4												
H.2.1												
H.3.1												
O.1.1												
O.1.2												
O.2.1												
O.2.2												
O.3.1												

Cutting data standard values – WTX – AL

Index	10 793 ...										
	with through coolant v_c (m/min)	12xD									
		\varnothing 3–4	\varnothing 4–5	\varnothing 5–6	\varnothing 6–8	\varnothing 8–10	\varnothing 10–12	\varnothing 12–14	\varnothing 14–16	\varnothing 16–18	\varnothing 18–20
f (mm/rev)											
P.1.1											
P.1.2											
P.1.3											
P.1.4											
P.1.5											
P.2.1											
P.2.2											
P.2.3											
P.2.4											
P.3.1											
P.3.2											
P.3.3											
P.4.1											
P.4.2											
M.1.1											
M.2.1											
M.3.1											
K.1.1											
K.1.2											
K.2.1											
K.2.2											
K.3.1											
K.3.2											
N.1.1	250	0,20	0,23	0,25	0,29	0,32	0,35	0,40	0,45	0,50	0,55
N.1.2	280	0,20	0,23	0,25	0,29	0,32	0,35	0,40	0,45	0,50	0,55
N.2.1	250	0,23	0,25	0,28	0,32	0,35	0,38	0,45	0,50	0,55	0,60
N.2.2	280	0,23	0,25	0,28	0,32	0,35	0,38	0,45	0,50	0,55	0,60
N.2.3	245	0,20	0,23	0,25	0,29	0,32	0,35	0,40	0,45	0,50	0,55
N.3.1	150	0,11	0,13	0,15	0,19	0,23	0,26	0,30	0,34	0,38	0,42
N.3.2	150	0,11	0,13	0,15	0,19	0,23	0,26	0,30	0,34	0,38	0,42
N.3.3	120	0,11	0,13	0,15	0,19	0,23	0,26	0,30	0,34	0,38	0,42
N.4.1											
S.1.1											
S.1.2											
S.2.1											
S.2.2											
S.2.3											
S.3.1											
S.3.2											
S.3.3											
H.1.1											
H.1.2											
H.1.3											
H.1.4											
H.2.1											
H.3.1											
O.1.1											
O.1.2											
O.2.1											
O.2.2											
O.3.1											

 The cutting data depends extremely on the external conditions, the material and machine type.
The indicated values are possible values which have to be increased or reduced according to the application conditions.

Cutting data standard values – WTX – HFDS – high-feed drill

Index	10 797 ...						10 798 ...					
	with through coolant v _c (m/min)	3xD					with through coolant v _c (m/min)	5xD				
		Ø 6–8	Ø 8–10	Ø 10–12	Ø 12–14	Ø 14–16		Ø 6–8	Ø 8–10	Ø 10–12	Ø 12–14	Ø 14–16
		f (mm/rev)						f (mm/rev)				
P.1.1	100	0,3–0,4	0,5–0,6	0,7–0,8	0,8–0,9	0,8–0,9	100	0,3–0,4	0,5–0,6	0,7–0,8	0,8–0,9	0,8–0,9
P.1.2	100	0,3–0,4	0,5–0,6	0,7–0,8	0,8–0,9	0,8–0,9	100	0,3–0,4	0,5–0,6	0,7–0,8	0,8–0,9	0,8–0,9
P.1.3	100	0,3–0,4	0,5–0,6	0,7–0,8	0,8–0,9	0,8–0,9	100	0,3–0,4	0,5–0,6	0,7–0,8	0,8–0,9	0,8–0,9
P.1.4	100	0,3–0,4	0,5–0,6	0,7–0,8	0,8–0,9	0,8–0,9	100	0,3–0,4	0,5–0,6	0,7–0,8	0,8–0,9	0,8–0,9
P.1.5	100	0,3–0,4	0,5–0,6	0,7–0,8	0,8–0,9	0,8–0,9	100	0,3–0,4	0,5–0,6	0,7–0,8	0,8–0,9	0,8–0,9
P.2.1	100	0,3–0,4	0,5–0,6	0,7–0,8	0,8–0,9	0,8–0,9	100	0,3–0,4	0,5–0,6	0,7–0,8	0,8–0,9	0,8–0,9
P.2.2	100	0,3–0,4	0,5–0,6	0,7–0,8	0,8–0,9	0,8–0,9	100	0,3–0,4	0,5–0,6	0,7–0,8	0,8–0,9	0,8–0,9
P.2.3	90	0,3–0,4	0,5–0,6	0,7–0,8	0,8–0,9	0,8–0,9	90	0,3–0,4	0,5–0,6	0,7–0,8	0,8–0,9	0,8–0,9
P.2.4	90	0,3–0,4	0,5–0,6	0,7–0,8	0,8–0,9	0,8–0,9	90	0,3–0,4	0,5–0,6	0,7–0,8	0,8–0,9	0,8–0,9
P.3.1	85	0,2–0,3	0,3–0,4	0,5–0,6	0,6–0,7	0,6–0,7	85	0,2–0,3	0,3–0,4	0,5–0,6	0,6–0,7	0,6–0,7
P.3.2	70	0,2–0,3	0,3–0,4	0,5–0,6	0,6–0,7	0,6–0,7	70	0,2–0,3	0,3–0,4	0,5–0,6	0,6–0,7	0,6–0,7
P.3.3	70	0,2–0,3	0,3–0,4	0,5–0,6	0,6–0,7	0,6–0,7	70	0,2–0,3	0,3–0,4	0,5–0,6	0,6–0,7	0,6–0,7
P.4.1	65	0,2–0,3	0,3–0,4	0,5–0,6	0,6–0,7	0,6–0,7	65	0,2–0,3	0,3–0,4	0,5–0,6	0,6–0,7	0,6–0,7
P.4.2	65	0,2–0,3	0,3–0,4	0,5–0,6	0,6–0,7	0,6–0,7	65	0,2–0,3	0,3–0,4	0,5–0,6	0,6–0,7	0,6–0,7
M.1.1	65	0,2–0,25	0,3–0,4	0,5–0,6	0,6–0,6	0,6–0,6	65	0,2–0,25	0,3–0,4	0,5–0,6	0,6–0,6	0,6–0,6
M.2.1	65	0,2–0,25	0,3–0,4	0,5–0,6	0,6–0,6	0,6–0,6	65	0,2–0,25	0,3–0,4	0,5–0,6	0,6–0,6	0,6–0,6
M.3.1	55	0,2–0,25	0,3–0,4	0,5–0,6	0,6–0,6	0,6–0,6	55	0,2–0,25	0,3–0,4	0,5–0,6	0,6–0,6	0,6–0,6
K.1.1	130	0,4–0,6	0,5–0,7	0,6–0,8	0,7–0,9	0,7–0,9	130	0,4–0,6	0,5–0,7	0,6–0,8	0,7–0,9	0,7–0,9
K.1.2	130	0,4–0,6	0,5–0,7	0,6–0,8	0,7–0,9	0,7–0,9	130	0,4–0,6	0,5–0,7	0,6–0,8	0,7–0,9	0,7–0,9
K.2.1	130	0,4–0,6	0,5–0,7	0,6–0,8	0,7–0,9	0,7–0,9	130	0,4–0,6	0,5–0,7	0,6–0,8	0,7–0,9	0,7–0,9
K.2.2	130	0,4–0,6	0,5–0,7	0,6–0,8	0,7–0,9	0,7–0,9	130	0,4–0,6	0,5–0,7	0,6–0,8	0,7–0,9	0,7–0,9
K.3.1	130	0,4–0,6	0,5–0,7	0,6–0,8	0,7–0,9	0,7–0,9	130	0,4–0,6	0,5–0,7	0,6–0,8	0,7–0,9	0,7–0,9
K.3.2	130	0,4–0,6	0,5–0,7	0,6–0,8	0,7–0,9	0,7–0,9	130	0,4–0,6	0,5–0,7	0,6–0,8	0,7–0,9	0,7–0,9
N.1.1												
N.1.2												
N.2.1												
N.2.2												
N.2.3												
N.3.1	130	0,4–0,6	0,5–0,7	0,6–0,8	0,7–0,9	0,7–0,9	130	0,4–0,6	0,5–0,7	0,6–0,8	0,7–0,9	0,7–0,9
N.3.2	130	0,4–0,6	0,5–0,7	0,6–0,8	0,7–0,9	0,7–0,9	130	0,4–0,6	0,5–0,7	0,6–0,8	0,7–0,9	0,7–0,9
N.3.3	130	0,4–0,6	0,5–0,7	0,6–0,8	0,7–0,9	0,7–0,9	130	0,4–0,6	0,5–0,7	0,6–0,8	0,7–0,9	0,7–0,9
N.4.1	130	0,4–0,6	0,5–0,7	0,6–0,8	0,7–0,9	0,7–0,9	130	0,4–0,6	0,5–0,7	0,6–0,8	0,7–0,9	0,7–0,9
S.1.1												
S.1.2												
S.2.1												
S.2.2												
S.2.3												
S.3.1												
S.3.2												
S.3.3												
H.1.1												
H.1.2												
H.1.3												
H.1.4												
H.2.1												
H.3.1												
O.1.1												
O.1.2												
O.2.1												
O.2.2												
O.3.1	110	0,6	0,6	0,8	0,9	1,0	110	0,6	0,6	0,8	0,9	1,0

 The cutting data depends extremely on the external conditions, the material and machine type.
The indicated values are possible values which have to be increased or reduced according to the application conditions.

Cutting data standard values – WTX – 180

Index	10 720 ...					
	3xD					
	with through coolant	Ø 3–5	Ø 5–8	Ø 8–12	Ø 12–16	Ø 16–20
	v_c (m/min)	f (mm/rev)				
P.1.1	90	0,09	0,13	0,18	0,22	0,25
P.1.2	85	0,09	0,13	0,17	0,21	0,24
P.1.3	80	0,09	0,12	0,16	0,20	0,23
P.1.4	75	0,08	0,12	0,16	0,19	0,22
P.1.5	70	0,08	0,11	0,15	0,18	0,20
P.2.1	90	0,11	0,16	0,21	0,26	0,29
P.2.2	80	0,10	0,14	0,19	0,24	0,27
P.2.3	70	0,09	0,13	0,17	0,21	0,24
P.2.4	55	0,09	0,12	0,16	0,19	0,21
P.3.1	60	0,09	0,13	0,17	0,21	0,24
P.3.2	50	0,08	0,11	0,14	0,17	0,20
P.3.3	50	0,06	0,09	0,11	0,14	0,15
P.4.1	50	0,06	0,09	0,11	0,14	0,16
P.4.2	50	0,06	0,09	0,11	0,14	0,16
M.1.1	45	0,06	0,09	0,11	0,14	0,16
M.2.1	40	0,05	0,07	0,10	0,12	0,14
M.3.1	40	0,05	0,07	0,10	0,12	0,14
K.1.1	95	0,12	0,19	0,26	0,33	0,38
K.1.2	80	0,11	0,16	0,21	0,26	0,30
K.2.1	130	0,12	0,18	0,25	0,30	0,35
K.2.2	80	0,11	0,16	0,21	0,26	0,30
K.3.1	70	0,12	0,17	0,23	0,28	0,32
K.3.2	65	0,10	0,14	0,18	0,22	0,25
N.1.1						
N.1.2						
N.2.1						
N.2.2						
N.2.3						
N.3.1						
N.3.2						
N.3.3						
N.4.1						
S.1.1						
S.1.2						
S.2.1						
S.2.2						
S.2.3						
S.3.1						
S.3.2						
S.3.3						
H.1.1						
H.1.2						
H.1.3						
H.1.4						
H.2.1						
H.3.1						
O.1.1						
O.1.2						
O.2.1						
O.2.2						
O.3.1						

Index	10 721 ...					
	with through coolant v _c (m/min)	5xD				
		Ø 3-5	Ø 5-8	Ø 8-12	Ø 12-16	Ø 16-20
f (mm/rev)						
P.1.1	90	0,09	0,13	0,18	0,22	0,25
P.1.2	85	0,09	0,13	0,17	0,21	0,24
P.1.3	80	0,09	0,12	0,16	0,20	0,23
P.1.4	75	0,08	0,12	0,16	0,19	0,22
P.1.5	70	0,08	0,11	0,15	0,18	0,20
P.2.1	90	0,11	0,16	0,21	0,26	0,29
P.2.2	80	0,10	0,14	0,19	0,24	0,27
P.2.3	70	0,09	0,13	0,17	0,21	0,24
P.2.4	55	0,09	0,12	0,16	0,19	0,21
P.3.1	60	0,09	0,13	0,17	0,21	0,24
P.3.2	50	0,08	0,11	0,14	0,17	0,20
P.3.3	50	0,06	0,09	0,11	0,14	0,15
P.4.1	50	0,06	0,09	0,11	0,14	0,16
P.4.2	50	0,06	0,09	0,11	0,14	0,16
M.1.1	45	0,06	0,09	0,11	0,14	0,16
M.2.1	40	0,05	0,07	0,10	0,12	0,14
M.3.1	40	0,05	0,07	0,10	0,12	0,14
K.1.1	95	0,12	0,19	0,26	0,33	0,38
K.1.2	80	0,11	0,16	0,21	0,26	0,30
K.2.1	130	0,12	0,18	0,25	0,30	0,35
K.2.2	80	0,11	0,16	0,21	0,26	0,30
K.3.1	70	0,12	0,17	0,23	0,28	0,32
K.3.2	65	0,10	0,14	0,18	0,22	0,25
N.1.1						
N.1.2						
N.2.1						
N.2.2						
N.2.3						
N.3.1						
N.3.2						
N.3.3						
N.4.1						
S.1.1						
S.1.2						
S.2.1						
S.2.2						
S.2.3						
S.3.1						
S.3.2						
S.3.3						
H.1.1						
H.1.2						
H.1.3						
H.1.4						
H.2.1						
H.3.1						
O.1.1						
O.1.2						
O.2.1						
O.2.2						
O.3.1						



Application Note:

Spot drilling with reduced feedrate

1. Feedrate f [mm/U] should be multiplied by correction factor A_k
2. Drill with reduced feed rate until tool is fully engaged in workpiece by approximately 0.25 x D
3. Retract from the hole at double the feed rate f in mm/U – only with inclined surfaces

This operation is necessary in order to achieve maximum performance of the drill!
4. Drill the hole with feed rate f [mm/U] without pecking for chip evacuation

Correction factor A _k for f [mm/U] when spot drilling		
Inclination workpiece surface	A _k to 3xD (10 720 ...)	A _k to 5xD (10 721 ...)
15°	0,5	0,25
30°	0,4	not recommended
45°	0,25	not recommended



For drilling on flat surfaces (inclination 0 °) with the WTX – 180 5xD, we recommend the use of a pilot drill (WTX – UNI 3xD).

Cutting data standard values – type UNI

Index	11 706 ..., 11 707 ..., 11 709 ..., 11 710 ...																
	without through coolant v_c (m/min)	3xD / 5xD															
		$\leq \emptyset 1$	$\emptyset 1-1,25$	$\emptyset 1,25-1,5$	$\emptyset 1,5-2$	$\emptyset 2-2,5$	$\emptyset 2,5-3$	$\emptyset 3-4$	$\emptyset 4-5$	$\emptyset 5-6$	$\emptyset 6-8$	$\emptyset 8-10$	$\emptyset 10-12$	$\emptyset 12-14$	$\emptyset 14-16$	$\emptyset 16-18$	$\emptyset 18-20$
		f (mm/rev)															
P.1.1	90	0,03	0,04	0,05	0,06	0,08	0,09	0,13	0,16	0,19	0,22	0,25	0,28	0,31	0,34	0,36	0,38
P.1.2	75	0,03	0,03	0,04	0,05	0,07	0,08	0,12	0,15	0,18	0,21	0,24	0,27	0,30	0,32	0,35	0,37
P.1.3	75	0,03	0,03	0,04	0,05	0,07	0,08	0,12	0,15	0,18	0,21	0,24	0,27	0,30	0,32	0,35	0,37
P.1.4	70	0,02	0,02	0,03	0,03	0,04	0,05	0,06	0,08	0,10	0,12	0,14	0,15	0,18	0,20	0,23	0,25
P.1.5	70	0,02	0,02	0,03	0,03	0,04	0,05	0,06	0,08	0,10	0,12	0,14	0,15	0,18	0,20	0,23	0,25
P.2.1	80	0,03	0,04	0,05	0,06	0,08	0,09	0,13	0,16	0,19	0,22	0,25	0,28	0,31	0,34	0,36	0,38
P.2.2	70	0,03	0,03	0,04	0,05	0,07	0,08	0,12	0,15	0,18	0,21	0,24	0,27	0,30	0,32	0,35	0,37
P.2.3	70	0,02	0,02	0,03	0,03	0,04	0,05	0,06	0,08	0,10	0,12	0,14	0,15	0,18	0,20	0,23	0,25
P.2.4	55	0,02	0,02	0,03	0,03	0,04	0,05	0,06	0,08	0,10	0,12	0,14	0,15	0,18	0,20	0,23	0,25
P.3.1	70	0,02	0,02	0,03	0,03	0,04	0,05	0,06	0,08	0,10	0,12	0,14	0,15	0,18	0,20	0,23	0,25
P.3.2	55	0,02	0,02	0,03	0,03	0,04	0,05	0,06	0,08	0,10	0,12	0,14	0,15	0,18	0,20	0,23	0,25
P.3.3																	
P.4.1																	
P.4.2																	
M.1.1																	
M.2.1																	
M.3.1																	
K.1.1	90	0,04	0,05	0,06	0,08	0,10	0,13	0,16	0,18	0,22	0,25	0,29	0,33	0,37	0,40	0,43	0,46
K.1.2	75	0,04	0,05	0,06	0,08	0,10	0,13	0,16	0,18	0,22	0,25	0,29	0,33	0,37	0,40	0,43	0,46
K.2.1	75	0,03	0,03	0,04	0,05	0,06	0,08	0,10	0,13	0,15	0,18	0,20	0,23	0,26	0,30	0,34	0,38
K.2.2	70	0,03	0,03	0,04	0,05	0,06	0,08	0,10	0,13	0,15	0,18	0,20	0,23	0,26	0,30	0,34	0,38
K.3.1	75	0,03	0,03	0,04	0,05	0,06	0,08	0,10	0,13	0,15	0,18	0,20	0,23	0,26	0,30	0,34	0,38
K.3.2	70	0,03	0,03	0,04	0,05	0,06	0,08	0,10	0,13	0,15	0,18	0,20	0,23	0,26	0,30	0,34	0,38
N.1.1																	
N.1.2																	
N.2.1																	
N.2.2																	
N.2.3																	
N.3.1																	
N.3.2																	
N.3.3																	
N.4.1																	
S.1.1																	
S.1.2																	
S.2.1																	
S.2.2																	
S.2.3																	
S.3.1																	
S.3.2																	
S.3.3																	
H.1.1																	
H.1.2																	
H.1.3																	
H.1.4																	
H.2.1																	
H.3.1																	
O.1.1																	
O.1.2																	
O.2.1																	
O.2.2																	
O.3.1																	

 The cutting data is strongly influenced by external conditions, such as the stability of the tool and workpiece clamping, material and type of machine. The specified values represent guideline cutting data that must be corrected according to the usage conditions.

Index	11 700 ..., 11 701 ..., 11 702 ..., 11 703 ...																	
	with through coolant v _c (m/min)	3xD / 5xD																
		≤ Ø 1	Ø 1-1,25	Ø 1,25-1,5	Ø 1,5-2	Ø 2-2,5	Ø 2,5-3	Ø 3-4	Ø 4-5	Ø 5-6	Ø 6-8	Ø 8-10	Ø 10-12	Ø 12-14	Ø 14-16	Ø 16-18	Ø 18-20	
		f (mm/rev)																
P.1.1	115	0,03	0,04	0,05	0,06	0,08	0,09	0,13	0,16	0,19	0,22	0,25	0,28	0,31	0,34	0,36	0,38	
P.1.2	95	0,03	0,03	0,04	0,05	0,07	0,08	0,12	0,15	0,18	0,21	0,24	0,27	0,30	0,32	0,35	0,37	
P.1.3	95	0,03	0,03	0,04	0,05	0,07	0,08	0,12	0,15	0,18	0,21	0,24	0,27	0,30	0,32	0,35	0,37	
P.1.4	85	0,02	0,02	0,03	0,03	0,04	0,05	0,06	0,08	0,10	0,12	0,14	0,15	0,18	0,20	0,23	0,25	
P.1.5	85	0,02	0,02	0,03	0,03	0,04	0,05	0,06	0,08	0,10	0,12	0,14	0,15	0,18	0,20	0,23	0,25	
P.2.1	95	0,03	0,04	0,05	0,06	0,08	0,09	0,13	0,16	0,19	0,22	0,25	0,28	0,31	0,34	0,36	0,38	
P.2.2	85	0,03	0,03	0,04	0,05	0,07	0,08	0,12	0,15	0,18	0,21	0,24	0,27	0,30	0,32	0,35	0,37	
P.2.3	85	0,02	0,02	0,03	0,03	0,04	0,05	0,06	0,08	0,10	0,12	0,14	0,15	0,18	0,20	0,23	0,25	
P.2.4	70	0,02	0,02	0,03	0,03	0,04	0,05	0,06	0,08	0,10	0,12	0,14	0,15	0,18	0,20	0,23	0,25	
P.3.1	85	0,02	0,02	0,03	0,03	0,04	0,05	0,06	0,08	0,10	0,12	0,14	0,15	0,18	0,20	0,23	0,25	
P.3.2	70	0,02	0,02	0,03	0,03	0,04	0,05	0,06	0,08	0,10	0,12	0,14	0,15	0,18	0,20	0,23	0,25	
P.3.3	40	0,02	0,02	0,03	0,03	0,04	0,05	0,06	0,08	0,10	0,12	0,14	0,15	0,18	0,20	0,23	0,25	
P.4.1	50	0,02	0,02	0,03	0,03	0,04	0,05	0,06	0,08	0,10	0,12	0,14	0,15	0,18	0,20	0,23	0,25	
P.4.2	30	0,02	0,02	0,03	0,03	0,04	0,05	0,06	0,08	0,10	0,12	0,14	0,15	0,18	0,20	0,23	0,25	
M.1.1	35	0,02	0,02	0,03	0,03	0,04	0,05	0,06	0,08	0,10	0,12	0,14	0,15	0,18	0,20	0,23	0,25	
M.2.1	35	0,02	0,02	0,03	0,03	0,04	0,05	0,06	0,08	0,10	0,12	0,14	0,15	0,18	0,20	0,23	0,25	
M.3.1	35	0,02	0,02	0,03	0,03	0,04	0,05	0,06	0,08	0,10	0,12	0,14	0,15	0,18	0,20	0,23	0,25	
K.1.1	115	0,04	0,05	0,06	0,08	0,10	0,13	0,16	0,18	0,22	0,25	0,29	0,33	0,37	0,40	0,43	0,46	
K.1.2	95	0,04	0,05	0,06	0,08	0,10	0,13	0,16	0,18	0,22	0,25	0,29	0,33	0,37	0,40	0,43	0,46	
K.2.1	95	0,03	0,03	0,04	0,05	0,06	0,08	0,10	0,13	0,15	0,18	0,20	0,23	0,26	0,30	0,34	0,38	
K.2.2	90	0,03	0,03	0,04	0,05	0,06	0,08	0,10	0,13	0,15	0,18	0,20	0,23	0,26	0,30	0,34	0,38	
K.3.1	95	0,03	0,03	0,04	0,05	0,06	0,08	0,10	0,13	0,15	0,18	0,20	0,23	0,26	0,30	0,34	0,38	
K.3.2	90	0,03	0,03	0,04	0,05	0,06	0,08	0,10	0,13	0,15	0,18	0,20	0,23	0,26	0,30	0,34	0,38	
N.1.1	200	0,03	0,03	0,04	0,05	0,07	0,08	0,12	0,15	0,18	0,21	0,24	0,27	0,30	0,32	0,35	0,37	
N.1.2	200	0,03	0,03	0,04	0,05	0,07	0,08	0,12	0,15	0,18	0,21	0,24	0,27	0,30	0,32	0,35	0,37	
N.2.1	160	0,03	0,03	0,04	0,05	0,06	0,08	0,10	0,11	0,13	0,15	0,18	0,20	0,23	0,26	0,29	0,33	
N.2.2	160	0,03	0,03	0,04	0,05	0,06	0,08	0,10	0,11	0,13	0,15	0,18	0,20	0,23	0,26	0,29	0,33	
N.2.3	140	0,02	0,02	0,03	0,03	0,04	0,05	0,06	0,08	0,10	0,12	0,14	0,15	0,18	0,20	0,23	0,25	
N.3.1	120	0,02	0,02	0,03	0,03	0,04	0,05	0,07	0,08	0,10	0,11	0,12	0,13	0,14	0,15	0,16	0,18	
N.3.2	120	0,02	0,02	0,03	0,03	0,04	0,05	0,07	0,08	0,10	0,11	0,12	0,13	0,14	0,15	0,16	0,18	
N.3.3	100	0,02	0,02	0,03	0,03	0,04	0,05	0,07	0,08	0,10	0,11	0,12	0,13	0,14	0,15	0,16	0,18	
N.4.1																		
S.1.1																		
S.1.2																		
S.2.1																		
S.2.2																		
S.2.3																		
S.3.1																		
S.3.2																		
S.3.3																		
H.1.1																		
H.1.2																		
H.1.3																		
H.1.4																		
H.2.1																		
H.3.1																		
O.1.1																		
O.1.2																		
O.2.1																		
O.2.2																		
O.3.1																		

Cutting data standard values – type UNI

Index	11 704 ...										
	with through coolant v_c (m/min)	8xD									
		\varnothing 3–4	\varnothing 4–5	\varnothing 5–6	\varnothing 6–8	\varnothing 8–10	\varnothing 10–12	\varnothing 12–14	\varnothing 14–16	\varnothing 16–18	\varnothing 18–20
		f (mm/rev)									
P.1.1	100	0,13	0,16	0,19	0,22	0,25	0,28	0,31	0,34	0,36	0,38
P.1.2	80	0,12	0,15	0,18	0,21	0,24	0,27	0,30	0,32	0,35	0,37
P.1.3	80	0,12	0,15	0,18	0,21	0,24	0,27	0,30	0,32	0,35	0,37
P.1.4	75	0,06	0,08	0,10	0,12	0,14	0,15	0,18	0,20	0,23	0,25
P.1.5	75	0,06	0,08	0,10	0,12	0,14	0,15	0,18	0,20	0,23	0,25
P.2.1	80	0,13	0,16	0,19	0,22	0,25	0,28	0,31	0,34	0,36	0,38
P.2.2	75	0,12	0,15	0,18	0,21	0,24	0,27	0,30	0,32	0,35	0,37
P.2.3	75	0,06	0,08	0,10	0,12	0,14	0,15	0,18	0,20	0,23	0,25
P.2.4	60	0,06	0,08	0,10	0,12	0,14	0,15	0,18	0,20	0,23	0,25
P.3.1	75	0,06	0,08	0,10	0,12	0,14	0,15	0,18	0,20	0,23	0,25
P.3.2	60	0,06	0,08	0,10	0,12	0,14	0,15	0,18	0,20	0,23	0,25
P.3.3	35	0,06	0,08	0,10	0,12	0,14	0,15	0,18	0,20	0,23	0,25
P.4.1	40	0,06	0,08	0,10	0,12	0,14	0,15	0,18	0,20	0,23	0,25
P.4.2	25	0,06	0,08	0,10	0,12	0,14	0,15	0,18	0,20	0,23	0,25
M.1.1	30	0,06	0,08	0,10	0,12	0,14	0,15	0,18	0,20	0,23	0,25
M.2.1	30	0,06	0,08	0,10	0,12	0,14	0,15	0,18	0,20	0,23	0,25
M.3.1	30	0,06	0,08	0,10	0,12	0,14	0,15	0,18	0,20	0,23	0,25
K.1.1	100	0,16	0,18	0,22	0,25	0,29	0,33	0,37	0,40	0,43	0,46
K.1.2	80	0,16	0,18	0,22	0,25	0,29	0,33	0,37	0,40	0,43	0,46
K.2.1	80	0,10	0,13	0,15	0,18	0,20	0,23	0,26	0,30	0,34	0,38
K.2.2	75	0,10	0,13	0,15	0,18	0,20	0,23	0,26	0,30	0,34	0,38
K.3.1	80	0,10	0,13	0,15	0,18	0,20	0,23	0,26	0,30	0,34	0,38
K.3.2	75	0,10	0,13	0,15	0,18	0,20	0,23	0,26	0,30	0,34	0,38
N.1.1											
N.1.2											
N.2.1											
N.2.2											
N.2.3											
N.3.1											
N.3.2											
N.3.3											
N.4.1											
S.1.1											
S.1.2											
S.2.1											
S.2.2											
S.2.3											
S.3.1											
S.3.2											
S.3.3											
H.1.1											
H.1.2											
H.1.3											
H.1.4											
H.2.1											
H.3.1											
O.1.1											
O.1.2											
O.2.1											
O.2.2											
O.3.1											



The cutting data is highly dependent on external conditions, such as stability of the tool and workpiece clamping, material and machine type!
The values indicated represent possible cutting data which may need to be corrected depending on operating conditions !

Index	11 705 ...											
	with through coolant v _c (m/min)	12xD										
		Ø 3-4	Ø 4-5	Ø 5-6	Ø 6-8	Ø 8-10	Ø 10-12	Ø 12-14	Ø 14-16	Ø 16-18	Ø 18-20	
		f (mm/rev)										
P.1.1	90	0,13	0,16	0,19	0,22	0,25	0,28	0,31	0,34	0,36	0,38	
P.1.2	75	0,12	0,15	0,18	0,21	0,24	0,27	0,30	0,32	0,35	0,37	
P.1.3	75	0,12	0,15	0,18	0,21	0,24	0,27	0,30	0,32	0,35	0,37	
P.1.4	70	0,06	0,08	0,10	0,12	0,14	0,15	0,18	0,20	0,23	0,25	
P.1.5	70	0,06	0,08	0,10	0,12	0,14	0,15	0,18	0,20	0,23	0,25	
P.2.1	80	0,13	0,16	0,19	0,22	0,25	0,28	0,31	0,34	0,36	0,38	
P.2.2	70	0,12	0,15	0,18	0,21	0,24	0,27	0,30	0,32	0,35	0,37	
P.2.3	70	0,06	0,08	0,10	0,12	0,14	0,15	0,18	0,20	0,23	0,25	
P.2.4	55	0,06	0,08	0,10	0,12	0,14	0,15	0,18	0,20	0,23	0,25	
P.3.1	70	0,06	0,08	0,10	0,12	0,14	0,15	0,18	0,20	0,23	0,25	
P.3.2	55	0,06	0,08	0,10	0,12	0,14	0,15	0,18	0,20	0,23	0,25	
P.3.3	35	0,06	0,08	0,10	0,12	0,14	0,15	0,18	0,20	0,23	0,25	
P.4.1	40	0,06	0,08	0,10	0,12	0,14	0,15	0,18	0,20	0,23	0,25	
P.4.2	25	0,06	0,08	0,10	0,12	0,14	0,15	0,18	0,20	0,23	0,25	
M.1.1	30	0,06	0,08	0,10	0,12	0,14	0,15	0,18	0,20	0,23	0,25	
M.2.1	30	0,06	0,08	0,10	0,12	0,14	0,15	0,18	0,20	0,23	0,25	
M.3.1	30	0,06	0,08	0,10	0,12	0,14	0,15	0,18	0,20	0,23	0,25	
K.1.1	90	0,16	0,18	0,22	0,25	0,29	0,33	0,37	0,40	0,43	0,46	
K.1.2	75	0,16	0,18	0,22	0,25	0,29	0,33	0,37	0,40	0,43	0,46	
K.2.1	75	0,10	0,13	0,15	0,18	0,20	0,23	0,26	0,30	0,34	0,38	
K.2.2	70	0,10	0,13	0,15	0,18	0,20	0,23	0,26	0,30	0,34	0,38	
K.3.1	75	0,10	0,13	0,15	0,18	0,20	0,23	0,26	0,30	0,34	0,38	
K.3.2	70	0,10	0,13	0,15	0,18	0,20	0,23	0,26	0,30	0,34	0,38	
N.1.1												
N.1.2												
N.2.1												
N.2.2												
N.2.3												
N.3.1												
N.3.2												
N.3.3												
N.4.1												
S.1.1												
S.1.2												
S.2.1												
S.2.2												
S.2.3												
S.3.1												
S.3.2												
S.3.3												
H.1.1												
H.1.2												
H.1.3												
H.1.4												
H.2.1												
H.3.1												
O.1.1												
O.1.2												
O.2.1												
O.2.2												
O.3.1												

Cutting data standard values – type VA

Index	11 711 ..., 11 712 ...																
	without through coolant v _c (m/min)	3xD															
		≤ Ø 1	Ø 1–1,25	Ø 1,25–1,5	Ø 1,5–2	Ø 2–2,5	Ø 2,5–3	Ø 3–4	Ø 4–5	Ø 5–6	Ø 6–8	Ø 8–10	Ø 10–12	Ø 12–14	Ø 14–16	Ø 16–18	Ø 18–20
		f (mm/rev)															
P.1.1	75	0,03	0,03	0,04	0,05	0,07	0,08	0,10	0,11	0,12	0,15	0,18	0,20	0,23	0,24	0,26	0,27
P.1.2																	
P.1.3																	
P.1.4																	
P.1.5																	
P.2.1	65	0,03	0,03	0,04	0,05	0,07	0,08	0,10	0,11	0,12	0,15	0,18	0,20	0,23	0,24	0,26	0,27
P.2.2	60	0,03	0,03	0,04	0,05	0,07	0,08	0,10	0,11	0,12	0,15	0,18	0,20	0,23	0,24	0,26	0,27
P.2.3																	
P.2.4																	
P.3.1																	
P.3.2																	
P.3.3																	
P.4.1	45	0,03	0,03	0,04	0,05	0,07	0,08	0,10	0,11	0,12	0,15	0,18	0,20	0,23	0,24	0,26	0,27
P.4.2	30	0,01	0,02	0,02	0,03	0,04	0,05	0,06	0,08	0,09	0,11	0,13	0,15	0,17	0,19	0,20	0,21
M.1.1	35	0,01	0,02	0,02	0,03	0,04	0,05	0,06	0,08	0,09	0,11	0,13	0,15	0,17	0,19	0,20	0,21
M.2.1	35	0,01	0,02	0,02	0,03	0,04	0,05	0,06	0,08	0,09	0,11	0,13	0,15	0,17	0,19	0,20	0,21
M.3.1	35	0,01	0,02	0,02	0,03	0,04	0,05	0,06	0,08	0,09	0,11	0,13	0,15	0,17	0,19	0,20	0,21
K.1.1																	
K.1.2																	
K.2.1																	
K.2.2																	
K.3.1																	
K.3.2																	
N.1.1	160	0,04	0,05	0,06	0,08	0,09	0,11	0,13	0,15	0,16	0,20	0,24	0,27	0,31	0,32	0,34	0,36
N.1.2	160	0,04	0,05	0,06	0,08	0,09	0,11	0,13	0,15	0,16	0,20	0,24	0,27	0,31	0,32	0,34	0,36
N.2.1	130	0,04	0,05	0,06	0,08	0,09	0,11	0,13	0,15	0,16	0,20	0,24	0,27	0,31	0,32	0,34	0,36
N.2.2	130	0,04	0,05	0,06	0,08	0,09	0,11	0,13	0,15	0,16	0,20	0,24	0,27	0,31	0,32	0,34	0,36
N.2.3	110	0,03	0,04	0,04	0,05	0,07	0,08	0,10	0,11	0,12	0,15	0,18	0,20	0,23	0,24	0,26	0,27
N.3.1	160	0,04	0,05	0,06	0,08	0,09	0,11	0,13	0,15	0,16	0,20	0,24	0,27	0,31	0,32	0,34	0,36
N.3.2	160	0,04	0,05	0,06	0,08	0,09	0,11	0,13	0,15	0,16	0,20	0,24	0,27	0,31	0,32	0,34	0,36
N.3.3	225	0,03	0,04	0,04	0,05	0,07	0,08	0,10	0,11	0,12	0,15	0,18	0,20	0,23	0,24	0,26	0,27
N.4.1																	
S.1.1																	
S.1.2																	
S.2.1																	
S.2.2																	
S.2.3																	
S.3.1	30	0,002	0,004	0,01	0,01	0,01	0,02	0,03	0,03	0,04	0,06	0,07	0,09	0,10	0,11	0,12	0,12
S.3.2	20	0,002	0,004	0,01	0,01	0,01	0,02	0,03	0,03	0,04	0,06	0,07	0,09	0,10	0,11	0,12	0,12
S.3.3																	
H.1.1																	
H.1.2																	
H.1.3																	
H.1.4																	
H.2.1																	
H.3.1																	
O.1.1	100	0,01	0,02	0,02	0,03	0,04	0,05	0,06	0,08	0,09	0,11	0,13	0,15	0,17	0,19	0,2	0,21
O.1.2	80	0,002	0,004	0,01	0,01	0,02	0,02	0,03	0,04	0,05	0,07	0,09	0,11	0,13	0,13	0,14	0,15
O.2.1																	
O.2.2																	
O.3.1																	



The cutting data is strongly influenced by external conditions, such as the stability of the tool and workpiece clamping, material and type of machine. The specified values represent guideline cutting data that must be corrected according to the usage conditions.

Index	11 713 ..., 11 714 ..., 11 715 ..., 11 716 ...																
	with through coolant v _c (m/min)	3xD / 5xD															
		≤ Ø 1	Ø 1-1,25	Ø 1,25-1,5	Ø 1,5-2	Ø 2-2,5	Ø 2,5-3	Ø 3-4	Ø 4-5	Ø 5-6	Ø 6-8	Ø 8-10	Ø 10-12	Ø 12-14	Ø 14-16	Ø 16-18	Ø 18-20
		f (mm/rev)															
P.1.1	85	0,03	0,03	0,04	0,05	0,07	0,08	0,10	0,11	0,12	0,15	0,18	0,20	0,23	0,24	0,26	0,27
P.1.2																	
P.1.3																	
P.1.4																	
P.1.5																	
P.2.1	75	0,03	0,03	0,04	0,05	0,07	0,08	0,10	0,11	0,12	0,15	0,18	0,20	0,23	0,24	0,26	0,27
P.2.2	65	0,03	0,03	0,04	0,05	0,07	0,08	0,10	0,11	0,12	0,15	0,18	0,20	0,23	0,24	0,26	0,27
P.2.3																	
P.2.4																	
P.3.1																	
P.3.2																	
P.3.3																	
P.4.1	55	0,03	0,03	0,04	0,05	0,07	0,08	0,10	0,11	0,12	0,15	0,18	0,20	0,23	0,24	0,26	0,27
P.4.2	40	0,01	0,02	0,02	0,03	0,04	0,05	0,06	0,08	0,09	0,11	0,13	0,15	0,17	0,19	0,20	0,21
M.1.1	45	0,01	0,02	0,02	0,03	0,04	0,05	0,06	0,08	0,09	0,11	0,13	0,15	0,17	0,19	0,20	0,21
M.2.1	45	0,01	0,02	0,02	0,03	0,04	0,05	0,06	0,08	0,09	0,11	0,13	0,15	0,17	0,19	0,20	0,21
M.3.1	45	0,01	0,02	0,02	0,03	0,04	0,05	0,06	0,08	0,09	0,11	0,13	0,15	0,17	0,19	0,20	0,21
K.1.1																	
K.1.2																	
K.2.1																	
K.2.2																	
K.3.1																	
K.3.2																	
N.1.1	200	0,04	0,05	0,06	0,08	0,09	0,11	0,13	0,15	0,16	0,20	0,24	0,27	0,31	0,32	0,34	0,36
N.1.2	200	0,04	0,05	0,06	0,08	0,09	0,11	0,13	0,15	0,16	0,20	0,24	0,27	0,31	0,32	0,34	0,36
N.2.1	160	0,04	0,05	0,06	0,08	0,09	0,11	0,13	0,15	0,16	0,20	0,24	0,27	0,31	0,32	0,34	0,36
N.2.2	160	0,04	0,05	0,06	0,08	0,09	0,11	0,13	0,15	0,16	0,20	0,24	0,27	0,31	0,32	0,34	0,36
N.2.3	140	0,03	0,03	0,04	0,05	0,07	0,08	0,10	0,11	0,12	0,15	0,18	0,2	0,23	0,24	0,26	0,27
N.3.1	200	0,04	0,05	0,06	0,08	0,09	0,11	0,13	0,15	0,16	0,20	0,24	0,27	0,31	0,32	0,34	0,36
N.3.2	200	0,04	0,05	0,06	0,08	0,09	0,11	0,13	0,15	0,16	0,20	0,24	0,27	0,31	0,32	0,34	0,36
N.3.3	280	0,03	0,03	0,04	0,05	0,07	0,08	0,10	0,11	0,12	0,15	0,18	0,20	0,23	0,24	0,26	0,27
N.4.1																	
S.1.1																	
S.1.2																	
S.2.1	15	0,002	0,004	0,01	0,01	0,01	0,02	0,03	0,03	0,04	0,06	0,07	0,09	0,10	0,11	0,12	0,12
S.2.2	15	0,002	0,004	0,01	0,01	0,01	0,02	0,03	0,03	0,04	0,06	0,07	0,09	0,10	0,11	0,12	0,12
S.2.3	15	0,002	0,004	0,01	0,01	0,01	0,02	0,03	0,03	0,04	0,06	0,07	0,09	0,10	0,11	0,12	0,12
S.3.1	35	0,002	0,004	0,01	0,01	0,01	0,02	0,03	0,03	0,04	0,06	0,07	0,09	0,10	0,11	0,12	0,12
S.3.2	25	0,002	0,004	0,01	0,01	0,01	0,02	0,03	0,03	0,04	0,06	0,07	0,09	0,10	0,11	0,12	0,12
S.3.3																	
H.1.1																	
H.1.2																	
H.1.3																	
H.1.4																	
H.2.1																	
H.3.1																	
O.1.1	120	0,01	0,02	0,02	0,03	0,04	0,05	0,06	0,08	0,09	0,11	0,13	0,15	0,17	0,19	0,20	0,21
O.1.2	100	0,002	0,004	0,01	0,01	0,02	0,02	0,03	0,04	0,05	0,07	0,09	0,11	0,13	0,13	0,14	0,15
O.2.1																	
O.2.2																	
O.3.1																	

Cutting data standard values – Type N – Twist drills

Index	10 700 ..., 10 710 ...														
	without through coolant v _c (m/min)	3xD / 5xD													
		≤ Ø 1	Ø 1–1,5	Ø 1,5–2	Ø 2–3	Ø 3–4	Ø 4–5	Ø 5–6	Ø 6–8	Ø 8–10	Ø 10–12	Ø 12–14	Ø 14–16	Ø 16–18	Ø 18–20
f (mm/rev)															
P.1.1	75	0,03	0,05	0,07	0,10	0,12	0,14	0,16	0,2	0,24	0,28	0,31	0,35	0,40	0,45
P.1.2	65	0,03	0,05	0,07	0,10	0,12	0,14	0,16	0,2	0,24	0,28	0,31	0,35	0,40	0,45
P.1.3	65	0,03	0,05	0,07	0,10	0,12	0,14	0,16	0,2	0,24	0,28	0,31	0,35	0,40	0,45
P.1.4	65	0,03	0,04	0,05	0,08	0,10	0,11	0,13	0,15	0,18	0,20	0,23	0,26	0,29	0,33
P.1.5	65	0,03	0,04	0,05	0,08	0,10	0,11	0,13	0,15	0,18	0,20	0,23	0,26	0,29	0,33
P.2.1	70	0,03	0,05	0,07	0,10	0,12	0,14	0,16	0,20	0,24	0,28	0,31	0,35	0,40	0,45
P.2.2	65	0,03	0,04	0,05	0,08	0,10	0,11	0,13	0,15	0,18	0,20	0,23	0,26	0,29	0,33
P.2.3	65	0,03	0,04	0,05	0,08	0,10	0,11	0,13	0,15	0,18	0,20	0,23	0,26	0,29	0,33
P.2.4	50	0,03	0,04	0,05	0,08	0,10	0,11	0,13	0,15	0,18	0,20	0,23	0,26	0,29	0,33
P.3.1	65	0,03	0,04	0,05	0,08	0,10	0,11	0,13	0,15	0,18	0,20	0,23	0,26	0,29	0,33
P.3.2	50	0,03	0,04	0,05	0,08	0,10	0,11	0,13	0,15	0,18	0,20	0,23	0,26	0,29	0,33
P.3.3															
P.4.1															
P.4.2															
M.1.1															
M.2.1															
M.3.1															
K.1.1	70	0,03	0,04	0,05	0,08	0,10	0,11	0,13	0,15	0,18	0,20	0,23	0,26	0,29	0,33
K.1.2	70	0,03	0,04	0,05	0,08	0,10	0,11	0,13	0,15	0,18	0,20	0,23	0,26	0,29	0,33
K.2.1	70	0,03	0,04	0,05	0,08	0,10	0,11	0,13	0,15	0,18	0,20	0,23	0,26	0,29	0,33
K.2.2	70	0,03	0,04	0,05	0,08	0,10	0,11	0,13	0,15	0,18	0,20	0,23	0,26	0,29	0,33
K.3.1	70	0,03	0,04	0,05	0,08	0,10	0,11	0,13	0,15	0,18	0,20	0,23	0,26	0,29	0,33
K.3.2	70	0,03	0,04	0,05	0,08	0,10	0,11	0,13	0,15	0,18	0,20	0,23	0,26	0,29	0,33
N.1.1	200	0,01	0,01	0,01	0,02	0,03	0,04	0,05	0,07	0,09	0,11	0,13	0,15	0,18	0,20
N.1.2	200	0,01	0,01	0,01	0,02	0,03	0,04	0,05	0,07	0,09	0,11	0,13	0,15	0,18	0,20
N.2.1	160	0,01	0,01	0,01	0,02	0,03	0,04	0,05	0,07	0,09	0,11	0,13	0,15	0,18	0,20
N.2.2	160	0,01	0,01	0,01	0,02	0,03	0,04	0,05	0,07	0,09	0,11	0,13	0,15	0,18	0,20
N.2.3	130	0,01	0,01	0,01	0,02	0,03	0,04	0,05	0,07	0,09	0,11	0,13	0,15	0,18	0,20
N.3.1	160	0,003	0,01	0,01	0,01	0,02	0,03	0,04	0,06	0,09	0,11	0,14	0,16	0,18	0,20
N.3.2	160	0,003	0,01	0,01	0,01	0,02	0,03	0,04	0,06	0,09	0,11	0,14	0,16	0,18	0,20
N.3.3	100	0,003	0,01	0,01	0,01	0,02	0,03	0,04	0,06	0,09	0,11	0,14	0,16	0,18	0,20
N.4.1	200	0,01	0,01	0,01	0,02	0,03	0,04	0,05	0,07	0,09	0,11	0,13	0,15	0,18	0,20
S.1.1															
S.1.2															
S.2.1															
S.2.2															
S.2.3															
S.3.1	30	0,002	0,003	0,003	0,01	0,01	0,02	0,03	0,04	0,05	0,06	0,07	0,08	0,09	0,10
S.3.2	20	0,002	0,003	0,003	0,01	0,01	0,02	0,03	0,04	0,05	0,06	0,07	0,08	0,09	0,10
S.3.3															
H.1.1															
H.1.2															
H.1.3															
H.1.4															
H.2.1															
H.3.1															
O.1.1															
O.1.2															
O.2.1															
O.2.2															
O.3.1															



The cutting data is highly dependent on external conditions, such as stability of the tool and workpiece clamping, material and machine type!
The values indicated represent possible cutting data which may need to be corrected depending on operating conditions !

Cutting data standard values – WTX – SB

Index	10 767 ..., 10 772 ..., 10 783 ..., 10 788 ...					
			3xD			
	without through coolant	with through coolant	Ø 2-5	Ø 5-8	Ø 8-12	Ø 12-16
	v _c (m/min)		f (mm/rev)			
P.1.1	110	120	0,13	0,18	0,25	0,30
P.1.2	105	115	0,12	0,18	0,24	0,29
P.1.3	100	110	0,12	0,17	0,23	0,28
P.1.4	95	105	0,11	0,16	0,21	0,26
P.1.5	90	100	0,11	0,15	0,20	0,25
P.2.1	105	120	0,15	0,22	0,29	0,36
P.2.2	95	110	0,14	0,20	0,27	0,33
P.2.3	85	100	0,13	0,18	0,24	0,29
P.2.4	65	75	0,12	0,16	0,21	0,26
P.3.1	70	85	0,12	0,18	0,24	0,29
P.3.2	60	65	0,11	0,15	0,20	0,24
P.3.3	50	65	0,09	0,12	0,15	0,19
P.4.1	50	65	0,08	0,12	0,16	0,19
P.4.2	50	65	0,08	0,12	0,16	0,19
M.1.1						
M.2.1						
M.3.1						
K.1.1	85	120	0,17	0,26	0,36	0,45
K.1.2	75	100	0,15	0,22	0,29	0,36
K.2.1	100	160	0,17	0,25	0,34	0,42
K.2.2	75	100	0,15	0,22	0,29	0,36
K.3.1	80	90	0,16	0,23	0,32	0,39
K.3.2	70	80	0,14	0,19	0,25	0,31
N.1.1						
N.1.2						
N.2.1						
N.2.2						
N.2.3						
N.3.1						
N.3.2						
N.3.3						
N.4.1						
S.1.1						
S.1.2						
S.2.1						
S.2.2						
S.2.3						
S.3.1						
S.3.2						
S.3.3						
H.1.1	25	25	0,06	0,08	0,11	0,14
H.1.2						
H.1.3						
H.1.4						
H.2.1	35	35	0,08	0,11	0,14	0,18
H.3.1						
O.1.1						
O.1.2						
O.2.1						
O.2.2						
O.3.1						



The cutting data depends extremely on the external conditions, the material and machine type.
The indicated values are possible values which have to be increased or reduced according to the application conditions.

Cutting data standard values – WTX – Mini

Index	11 770 ...				
	without through coolant v_c (m/min)	5xD			
		$\leq \varnothing 1,0$	$> \varnothing 1,0-1,5$	$> \varnothing 1,5-2,0$	$> \varnothing 2,0-2,9$
		f (mm/rev)			
P.1.1	75	0,01	0,01	0,013	0,015
P.1.2	65	0,02	0,02	0,025	0,03
P.1.3	65	0,01	0,01	0,013	0,015
P.1.4	65	0,01	0,01	0,013	0,015
P.1.5	70	0,01	0,01	0,013	0,015
P.2.1	70	0,01	0,01	0,013	0,015
P.2.2	65	0,01	0,01	0,013	0,015
P.2.3	65	0,02	0,02	0,025	0,03
P.2.4	65	0,01	0,01	0,013	0,015
P.3.1					
P.3.2					
P.3.3					
P.4.1					
P.4.2					
M.1.1					
M.2.1					
M.3.1					
K.1.1	70	0,01	0,01	0,013	0,015
K.1.2	70	0,01	0,01	0,013	0,015
K.2.1	70	0,01	0,01	0,013	0,015
K.2.2	70	0,01	0,01	0,013	0,015
K.3.1	70	0,01	0,01	0,013	0,015
K.3.2	70	0,01	0,01	0,013	0,015
N.1.1	200	0,01	0,01	0,013	0,015
N.1.2	200	0,01	0,01	0,013	0,015
N.2.1	160	0,01	0,01	0,013	0,015
N.2.2	180	0,01	0,01	0,013	0,015
N.2.3	130	0,01	0,01	0,013	0,015
N.3.1	160	0,01	0,01	0,013	0,015
N.3.2	160	0,01	0,01	0,013	0,015
N.3.3	100	0,01	0,01	0,013	0,015
N.4.1	200	0,01	0,01	0,013	0,015
S.1.1					
S.1.2					
S.2.1					
S.2.2					
S.2.3					
S.3.1	30	0,01	0,01	0,013	0,015
S.3.2	20	0,01	0,01	0,013	0,015
S.3.3					
H.1.1					
H.1.2					
H.1.3					
H.1.4					
H.2.1					
H.3.1					
O.1.1					
O.1.2					
O.2.1					
O.2.2					
O.3.1					



The cutting data depends extremely on the external conditions, the material and machine type.
The indicated values are possible values which have to be increased or reduced according to the application conditions.

Cutting data standard values – WTX – Micro

2

Index	10 693 ...							
	with through coolant v _c (m/min)	MMS	5xD					
			≤ Ø 1,0	> Ø 1,0–1,25	> Ø 1,25–1,5	> Ø 1,5–2,0	> Ø 2,0–2,5	> Ø 2,5–3,0
			f (mm/rev)					
P.1.1	70	51	0,028	0,034	0,045	0,070	0,095	0,115
P.1.2	60	43	0,028	0,034	0,045	0,070	0,095	0,115
P.1.3	60	43	0,028	0,034	0,045	0,070	0,095	0,115
P.1.4	60	43	0,028	0,034	0,045	0,070	0,095	0,115
P.1.5	60	43	0,028	0,034	0,045	0,070	0,095	0,115
P.2.1	70	51	0,028	0,034	0,045	0,070	0,095	0,115
P.2.2	60	43	0,028	0,034	0,045	0,070	0,095	0,115
P.2.3	60	43	0,028	0,034	0,045	0,070	0,095	0,115
P.2.4								
P.3.1	60	43	0,028	0,034	0,045	0,070	0,095	0,115
P.3.2	50	34	0,028	0,034	0,045	0,070	0,095	0,115
P.3.3								
P.4.1	50		0,015	0,018	0,024	0,040	0,060	0,080
P.4.2	35		0,015	0,018	0,024	0,040	0,060	0,080
M.1.1	40		0,015	0,018	0,024	0,040	0,060	0,080
M.2.1	40		0,015	0,018	0,024	0,040	0,060	0,080
M.3.1	40		0,015	0,018	0,024	0,040	0,060	0,080
K.1.1	70	51	0,028	0,034	0,045	0,070	0,095	0,115
K.1.2	70	51	0,028	0,034	0,045	0,070	0,095	0,115
K.2.1	70	51	0,028	0,034	0,045	0,070	0,095	0,115
K.2.2	70	51	0,028	0,034	0,045	0,070	0,095	0,115
K.3.1	70	51	0,028	0,034	0,045	0,070	0,095	0,115
K.3.2	70	51	0,028	0,034	0,045	0,070	0,095	0,115
N.1.1								
N.1.2								
N.2.1								
N.2.2								
N.2.3								
N.3.1								
N.3.2								
N.3.3								
N.4.1								
S.1.1	15		0,015	0,018	0,024	0,040	0,060	0,080
S.1.2	15		0,015	0,018	0,024	0,040	0,060	0,080
S.2.1	10		0,015	0,018	0,024	0,040	0,060	0,080
S.2.2	10		0,015	0,018	0,024	0,040	0,060	0,080
S.2.3								
S.3.1	30		0,015	0,018	0,024	0,040	0,060	0,080
S.3.2	20		0,015	0,018	0,024	0,040	0,060	0,080
S.3.3								
H.1.1								
H.1.2								
H.1.3								
H.1.4								
H.2.1								
H.3.1								
O.1.1								
O.1.2								
O.2.1								
O.2.2								
O.3.1								

Cutting data standard values – WTX – Micro

Index	10 694 ..., 10 695 ...							
	8xD / 12xD							
	with through coolant	MMS	≤ Ø 1,0	> Ø 1,0–1,25	> Ø 1,25–1,5	> Ø 1,5–2,0	> Ø 2,0–2,5	> Ø 2,5–3,0
	v_c (m/min)		f (mm/rev)					
P.1.1	70	51	0,028	0,034	0,045	0,070	0,095	0,115
P.1.2	60	43	0,028	0,034	0,045	0,070	0,095	0,115
P.1.3	60	43	0,028	0,034	0,045	0,070	0,095	0,115
P.1.4	60	43	0,028	0,034	0,045	0,070	0,095	0,115
P.1.5	60	43	0,028	0,034	0,045	0,070	0,095	0,115
P.2.1	70	51	0,028	0,034	0,045	0,070	0,095	0,115
P.2.2	60	43	0,028	0,034	0,045	0,070	0,095	0,115
P.2.3	60	43	0,028	0,034	0,045	0,070	0,095	0,115
P.2.4								
P.3.1	60	43	0,028	0,034	0,045	0,070	0,095	0,115
P.3.2	50	34	0,028	0,034	0,045	0,070	0,095	0,115
P.3.3								
P.4.1	50		0,015	0,018	0,024	0,040	0,060	0,080
P.4.2	35		0,015	0,018	0,024	0,040	0,060	0,080
M.1.1	40		0,015	0,018	0,024	0,040	0,060	0,080
M.2.1	40		0,015	0,018	0,024	0,040	0,060	0,080
M.3.1	40		0,015	0,018	0,024	0,040	0,060	0,080
K.1.1	70	51	0,028	0,034	0,045	0,070	0,095	0,115
K.1.2	70	51	0,028	0,034	0,045	0,070	0,095	0,115
K.2.1	70	51	0,028	0,034	0,045	0,070	0,095	0,115
K.2.2	70	51	0,028	0,034	0,045	0,070	0,095	0,115
K.3.1	70	51	0,028	0,034	0,045	0,070	0,095	0,115
K.3.2	70	51	0,028	0,034	0,045	0,070	0,095	0,115
N.1.1								
N.1.2								
N.2.1								
N.2.2								
N.2.3								
N.3.1								
N.3.2								
N.3.3								
N.4.1								
S.1.1	15		0,015	0,018	0,024	0,040	0,060	0,080
S.1.2	15		0,015	0,018	0,024	0,040	0,060	0,080
S.2.1	10		0,015	0,018	0,024	0,040	0,060	0,080
S.2.2	10		0,015	0,018	0,024	0,040	0,060	0,080
S.2.3								
S.3.1	30		0,015	0,018	0,024	0,040	0,060	0,080
S.3.2	20		0,015	0,018	0,024	0,040	0,060	0,080
S.3.3								
H.1.1								
H.1.2								
H.1.3								
H.1.4								
H.2.1								
H.3.1								
O.1.1								
O.1.2								
O.2.1								
O.2.2								
O.3.1								



The cutting data depends extremely on the external conditions, the material and machine type.
The indicated values are possible values which have to be increased or reduced according to the application conditions.

Index	10 696 ..., 10 697 ..., 10 698 ..., 10 699 ...							
	16xD / 20xD / 25xD / 30xD							
	with through coolant v _c (m/min)	≤ Ø 1,0	> Ø 1,0–1,25	> Ø 1,25–1,5	> Ø 1,5–2,0	> Ø 2,0–2,5	> Ø 2,5–3,0	
	f (mm/rev)							
P.1.1	58	0,028	0,034	0,045	0,070	0,095	0,115	
P.1.2	50	0,028	0,034	0,045	0,070	0,095	0,115	
P.1.3	50	0,028	0,034	0,045	0,070	0,095	0,115	
P.1.4	50	0,028	0,034	0,045	0,070	0,095	0,115	
P.1.5	50	0,028	0,034	0,045	0,070	0,095	0,115	
P.2.1	58	0,028	0,034	0,045	0,070	0,095	0,115	
P.2.2	50	0,028	0,034	0,045	0,070	0,095	0,115	
P.2.3	50	0,028	0,034	0,045	0,070	0,095	0,115	
P.2.4								
P.3.1	50	0,028	0,034	0,045	0,070	0,095	0,115	
P.3.2	42	0,028	0,034	0,045	0,070	0,095	0,115	
P.3.3								
P.4.1	42	0,015	0,018	0,024	0,040	0,060	0,080	
P.4.2	30	0,015	0,018	0,024	0,040	0,060	0,080	
M.1.1	34	0,015	0,018	0,024	0,040	0,060	0,080	
M.2.1	34	0,015	0,018	0,024	0,040	0,060	0,080	
M.3.1	34	0,015	0,018	0,024	0,040	0,060	0,080	
K.1.1	58	0,028	0,034	0,045	0,070	0,095	0,115	
K.1.2	58	0,028	0,034	0,045	0,070	0,095	0,115	
K.2.1	58	0,028	0,034	0,045	0,070	0,095	0,115	
K.2.2	58	0,028	0,034	0,045	0,070	0,095	0,115	
K.3.1	58	0,028	0,034	0,045	0,070	0,095	0,115	
K.3.2	58	0,028	0,034	0,045	0,070	0,095	0,115	
N.1.1								
N.1.2								
N.2.1								
N.2.2								
N.2.3								
N.3.1								
N.3.2								
N.3.3								
N.4.1								
S.1.1								
S.1.2								
S.2.1								
S.2.2								
S.2.3								
S.3.1								
S.3.2								
S.3.3								
H.1.1								
H.1.2								
H.1.3								
H.1.4								
H.2.1								
H.3.1								
O.1.1								
O.1.2								
O.2.1								
O.2.2								
O.3.1								



Pilot hole required for WTX – Micro deep hole twist drill – see recommended application for WTX – Micro on → page 161

Cutting data standard values – WTX – Feed BR

Index	10 707 ..., 10 711 ...										
	with through coolant	With external coolant v _c (m/min)	MMS	3xD							
				Ø 4	Ø 5	Ø 6	Ø 8	Ø 10	Ø 12	Ø 14	Ø 16
				f (mm/rev)							
P.1.1	75	70	70	0,19	0,22	0,25	0,31	0,36	0,40	0,44	0,47
P.1.2	75	65	65	0,18	0,21	0,24	0,30	0,34	0,39	0,42	0,45
P.1.3	70	65	65	0,17	0,20	0,23	0,28	0,33	0,37	0,40	0,43
P.1.4	65	60	60	0,16	0,19	0,22	0,27	0,31	0,35	0,38	0,41
P.1.5	65	55	55	0,16	0,18	0,21	0,25	0,29	0,33	0,36	0,39
P.2.1	75	65	65	0,22	0,26	0,30	0,37	0,43	0,48	0,52	0,56
P.2.2	70	60	60	0,20	0,24	0,27	0,33	0,39	0,43	0,47	0,51
P.2.3	65	55	55	0,18	0,22	0,25	0,30	0,35	0,39	0,43	0,46
P.2.4	50	40	40	0,17	0,20	0,22	0,27	0,31	0,35	0,38	0,40
P.3.1	55	45	45	0,18	0,21	0,24	0,30	0,35	0,39	0,43	0,46
P.3.2	40	40	40	0,15	0,18	0,20	0,25	0,29	0,32	0,35	0,37
P.3.3	40	30	35	0,13	0,15	0,16	0,20	0,23	0,25	0,27	0,29
P.4.1	40	30	35	0,12	0,14	0,16	0,20	0,23	0,26	0,28	0,30
P.4.2	40	30	35	0,12	0,14	0,16	0,20	0,23	0,26	0,28	0,30
M.1.1	40	25	25	0,09	0,11	0,12	0,15	0,17	0,19	0,21	0,23
M.2.1	35	20	20	0,08	0,09	0,10	0,13	0,15	0,17	0,18	0,19
M.3.1	35	20	20	0,08	0,09	0,10	0,13	0,15	0,17	0,18	0,19
K.1.1	100	70	70	0,25	0,30	0,35	0,45	0,53	0,60	0,66	0,71
K.1.2	85	65	65	0,22	0,26	0,30	0,37	0,43	0,48	0,53	0,56
K.2.1	135	85	100	0,24	0,29	0,34	0,42	0,49	0,56	0,61	0,66
K.2.2	85	65	65	0,22	0,26	0,30	0,37	0,43	0,48	0,53	0,56
K.3.1	75	70	70	0,23	0,28	0,32	0,39	0,46	0,52	0,57	0,61
K.3.2	70	60	60	0,20	0,23	0,26	0,32	0,37	0,41	0,45	0,48
N.1.1											
N.1.2											
N.2.1											
N.2.2											
N.2.3											
N.3.1											
N.3.2											
N.3.3											
N.4.1											
S.1.1											
S.1.2											
S.2.1											
S.2.2											
S.2.3											
S.3.1											
S.3.2											
S.3.3											
H.1.1											
H.1.2											
H.1.3											
H.1.4											
H.2.1											
H.3.1											
O.1.1											
O.1.2											
O.2.1											
O.2.2											
O.3.1											

 The cutting data is highly dependent on external conditions, such as stability of the tool and workpiece clamping, material and machine type!
The values indicated represent possible cutting data which may need to be corrected depending on operating conditions !

Index	10 713 ..., 10 719 ...													
	5xD													
	with through coolant	With external coolant v _c (m/min)	MMS	Ø 4	Ø 5	Ø 6	Ø 8	Ø 10	Ø 12	Ø 14	Ø 16	Ø 18	Ø 20	
	f (mm/rev)													
P.1.1	75	70	70	0,19	0,22	0,25	0,31	0,36	0,40	0,44	0,47	0,50	0,52	
P.1.2	75	65	65	0,18	0,21	0,24	0,30	0,34	0,39	0,42	0,45	0,48	0,50	
P.1.3	70	65	65	0,17	0,20	0,23	0,28	0,33	0,37	0,40	0,43	0,45	0,47	
P.1.4	65	60	60	0,16	0,19	0,22	0,27	0,31	0,35	0,38	0,41	0,43	0,45	
P.1.5	65	55	55	0,16	0,18	0,21	0,25	0,29	0,33	0,36	0,39	0,41	0,43	
P.2.1	75	65	65	0,22	0,26	0,30	0,37	0,43	0,48	0,52	0,56	0,59	0,62	
P.2.2	70	60	60	0,20	0,24	0,27	0,33	0,39	0,43	0,47	0,51	0,54	0,56	
P.2.3	65	55	55	0,18	0,22	0,25	0,30	0,35	0,39	0,43	0,46	0,48	0,50	
P.2.4	50	40	40	0,17	0,20	0,22	0,27	0,31	0,35	0,38	0,40	0,42	0,44	
P.3.1	55	45	45	0,18	0,21	0,24	0,30	0,35	0,39	0,43	0,46	0,48	0,50	
P.3.2	40	40	40	0,15	0,18	0,20	0,25	0,29	0,32	0,35	0,37	0,39	0,41	
P.3.3	40	30	35	0,13	0,15	0,16	0,20	0,23	0,25	0,27	0,29	0,30	0,32	
P.4.1	40	30	35	0,12	0,14	0,16	0,20	0,23	0,26	0,28	0,30	0,32	0,33	
P.4.2	40	30	35	0,12	0,14	0,16	0,20	0,23	0,26	0,28	0,30	0,32	0,33	
M.1.1	40	25	25	0,09	0,11	0,12	0,15	0,17	0,19	0,21	0,23	0,24	0,25	
M.2.1	35	20	20	0,08	0,09	0,10	0,13	0,15	0,17	0,18	0,19	0,20	0,21	
M.3.1	35	20	20	0,08	0,09	0,10	0,13	0,15	0,17	0,18	0,19	0,20	0,21	
K.1.1	100	70	70	0,25	0,30	0,35	0,45	0,53	0,60	0,66	0,71	0,75	0,79	
K.1.2	85	65	65	0,22	0,26	0,30	0,37	0,43	0,48	0,53	0,56	0,60	0,62	
K.2.1	135	85	100	0,24	0,29	0,34	0,42	0,49	0,56	0,61	0,66	0,69	0,72	
K.2.2	85	65	65	0,22	0,26	0,30	0,37	0,43	0,48	0,53	0,56	0,60	0,62	
K.3.1	75	70	70	0,23	0,28	0,32	0,39	0,46	0,52	0,57	0,61	0,64	0,67	
K.3.2	70	60	60	0,20	0,23	0,26	0,32	0,37	0,41	0,45	0,48	0,51	0,53	
N.1.1														
N.1.2														
N.2.1														
N.2.2														
N.2.3														
N.3.1														
N.3.2														
N.3.3														
N.4.1														
S.1.1														
S.1.2														
S.2.1														
S.2.2														
S.2.3														
S.3.1														
S.3.2														
S.3.3														
H.1.1														
H.1.2														
H.1.3														
H.1.4														
H.2.1														
H.3.1														
O.1.1														
O.1.2														
O.2.1														
O.2.2														
O.3.1														

Cutting data standard values – WTX – Co-pilot deep hole twist drills

Index	11 018 ...					
	20xD					
	with through coolant	Ø 3-4	Ø > 4-5	Ø > 5-6	Ø > 6-8	Ø > 8-10
	v _c (m/min)	f (mm/rev)				
P.1.1	100	0,07	0,08	0,10	0,12	0,14
P.1.2	90	0,07	0,08	0,10	0,12	0,14
P.1.3	90	0,05	0,06	0,08	0,10	0,11
P.1.4	90	0,05	0,06	0,08	0,10	0,11
P.1.5	95	0,05	0,06	0,08	0,10	0,11
P.2.1	95	0,07	0,08	0,10	0,12	0,14
P.2.2	90	0,05	0,06	0,08	0,10	0,11
P.2.3	90	0,07	0,08	0,10	0,12	0,14
P.2.4	90	0,05	0,06	0,08	0,10	0,11
P.3.1	45	0,03	0,04	0,05	0,06	0,08
P.3.2	70	0,05	0,06	0,08	0,10	0,11
P.3.3	70	0,05	0,06	0,08	0,10	0,11
P.4.1	70	0,03	0,04	0,05	0,06	0,08
P.4.2	45	0,03	0,04	0,05	0,06	0,08
M.1.1	50	0,03	0,04	0,05	0,06	0,08
M.2.1	50	0,03	0,04	0,05	0,06	0,08
M.3.1	50	0,03	0,04	0,05	0,06	0,08
K.1.1	100	0,10	0,13	0,15	0,19	0,23
K.1.2	95	0,10	0,13	0,15	0,19	0,23
K.2.1	100	0,08	0,10	0,13	0,16	0,18
K.2.2	95	0,08	0,10	0,13	0,16	0,18
K.3.1	100	0,08	0,10	0,13	0,16	0,18
K.3.2	95	0,08	0,10	0,13	0,16	0,18
N.1.1						
N.1.2						
N.2.1						
N.2.2						
N.2.3						
N.3.1						
N.3.2						
N.3.3						
N.4.1						
S.1.1						
S.1.2						
S.2.1						
S.2.2						
S.2.3	70	0,05	0,06	0,08	0,10	0,11
S.3.1	30	0,01	0,02	0,02	0,03	0,04
S.3.2	20	0,01	0,02	0,02	0,03	0,04
S.3.3						
H.1.1						
H.1.2						
H.1.3						
H.1.4						
H.2.1						
H.3.1						
O.1.1						
O.1.2						
O.2.1						
O.2.2						
O.3.1						



The cutting data depends extremely on the external conditions, the material and machine type.
The indicated values are possible values which have to be increased or reduced according to the application conditions.

Cutting data standard values – WTX – TB UNI

Index	11 016 ...									11 020 ...								
	with through coolant v _c (m/min)	16xD								with through coolant v _c (m/min)	20xD							
		∅ 2-3	∅ > 3-4	∅ > 4-5	∅ > 5-6	∅ > 6-8	∅ > 8-10	∅ > 10-12	∅ 2-3		∅ > 3-4	∅ > 4-5	∅ > 5-6	∅ > 6-8	∅ > 8-10	∅ > 10-12		
f (mm/rev)																		
P.1.1	105	0,05	0,07	0,08	0,10	0,12	0,14	0,16	100	0,05	0,07	0,08	0,10	0,12	0,14	0,16		
P.1.2	95	0,05	0,07	0,08	0,10	0,12	0,14	0,16	90	0,05	0,07	0,08	0,10	0,12	0,14	0,16		
P.1.3	95	0,04	0,05	0,06	0,08	0,10	0,11	0,13	90	0,04	0,05	0,06	0,08	0,10	0,11	0,13		
P.1.4	95	0,04	0,05	0,06	0,08	0,10	0,11	0,13	90	0,04	0,05	0,06	0,08	0,10	0,11	0,13		
P.1.5	100	0,04	0,05	0,06	0,01	0,10	0,11	0,13	95	0,04	0,05	0,06	0,08	0,10	0,11	0,13		
P.2.1	100	0,05	0,07	0,08	0,10	0,12	0,14	0,16	95	0,05	0,07	0,08	0,10	0,12	0,14	0,16		
P.2.2	95	0,04	0,05	0,06	0,10	0,10	0,11	0,13	90	0,04	0,05	0,06	0,08	0,10	0,11	0,13		
P.2.3	95	0,05	0,07	0,08	0,10	0,12	0,14	0,16	90	0,05	0,07	0,08	0,10	0,12	0,14	0,16		
P.2.4	95	0,04	0,05	0,06	0,10	0,10	0,11	0,13	90	0,04	0,05	0,06	0,08	0,10	0,11	0,13		
P.3.1	50	0,03	0,03	0,04	0,05	0,06	0,08	0,10	45	0,03	0,03	0,04	0,05	0,06	0,08	0,10		
P.3.2	75	0,04	0,05	0,06	0,10	0,10	0,11	0,13	70	0,04	0,05	0,06	0,08	0,10	0,11	0,13		
P.3.3	75	0,04	0,05	0,06	0,10	0,10	0,11	0,13	70	0,04	0,05	0,06	0,08	0,10	0,11	0,13		
P.4.1	75	0,03	0,03	0,04	0,05	0,06	0,08	0,10	70	0,03	0,03	0,04	0,05	0,06	0,08	0,10		
P.4.2	50	0,03	0,03	0,04	0,05	0,06	0,08	0,10	45	0,03	0,03	0,04	0,05	0,06	0,08	0,10		
M.1.1	55	0,03	0,03	0,04	0,05	0,06	0,08	0,10	50	0,03	0,03	0,04	0,05	0,06	0,08	0,10		
M.2.1	55	0,03	0,03	0,04	0,05	0,06	0,08	0,10	50	0,03	0,03	0,04	0,05	0,06	0,08	0,10		
M.3.1	55	0,03	0,03	0,04	0,05	0,06	0,08	0,10	50	0,03	0,03	0,04	0,05	0,06	0,08	0,10		
K.1.1	105	0,08	0,10	0,13	0,15	0,19	0,23	0,27	100	0,08	0,10	0,13	0,15	0,19	0,23	0,27		
K.1.2	100	0,08	0,10	0,13	0,15	0,19	0,23	0,27	95	0,08	0,10	0,13	0,15	0,19	0,23	0,27		
K.2.1	105	0,06	0,08	0,10	0,13	0,16	0,18	0,22	100	0,06	0,08	0,10	0,13	0,16	0,18	0,22		
K.2.2	100	0,06	0,08	0,10	0,13	0,16	0,18	0,22	95	0,06	0,08	0,10	0,13	0,16	0,18	0,22		
K.3.1	105	0,06	0,08	0,10	0,13	0,16	0,18	0,22	100	0,06	0,08	0,10	0,13	0,16	0,18	0,22		
K.3.2	100	0,06	0,08	0,10	0,13	0,16	0,18	0,22	95	0,06	0,08	0,10	0,13	0,16	0,18	0,22		
N.1.1																		
N.1.2																		
N.2.1																		
N.2.2																		
N.2.3																		
N.3.1																		
N.3.2																		
N.3.3																		
N.4.1																		
S.1.1																		
S.1.2																		
S.2.1																		
S.2.2																		
S.2.3	75	0,04	0,05	0,06	0,08	0,10	0,11	0,13	70	0,04	0,05	0,06	0,08	0,10	0,11	0,13		
S.3.1	35	0,01	0,01	0,02	0,02	0,03	0,04	0,05	30	0,01	0,01	0,02	0,02	0,03	0,04	0,05		
S.3.2	25	0,01	0,01	0,02	0,02	0,03	0,04	0,05	20	0,01	0,01	0,02	0,02	0,03	0,04	0,05		
S.3.3																		
H.1.1																		
H.1.2																		
H.1.3																		
H.1.4																		
H.2.1																		
H.3.1																		
O.1.1																		
O.1.2																		
O.2.1																		
O.2.2																		
O.3.1																		



All solid carbide WTX deep hole drills must be used with a pilot bore. The tool must never be run at high speed while not engaged in a material. Please refer to the strategy for the production of deep holes on → Page 160.

Cutting data standard values – WTX – TB UNI

Index	11 025 ...								11 030 ...							
	with through coolant v _c (m/min)	25xD							with through coolant v _c (m/min)	30xD						
		∅ 2-3	∅ >3-4	∅ >4-5	∅ >5-6	∅ >6-8	∅ >8-10	∅ >10-12		∅ 2-3	∅ >3-4	∅ >4-5	∅ >5-6	∅ >6-8	∅ >8-10	∅ >10-12
f (mm/rev)																
P.1.1	90	0,05	0,07	0,09	0,10	0,12	0,14	0,16	85	0,05	0,07	0,09	0,10	0,12	0,14	0,16
P.1.2	80	0,05	0,07	0,09	0,10	0,12	0,14	0,16	75	0,05	0,07	0,09	0,10	0,12	0,14	0,16
P.1.3	80	0,04	0,05	0,06	0,08	0,10	0,11	0,13	75	0,04	0,05	0,06	0,08	0,10	0,11	0,13
P.1.4	80	0,04	0,05	0,06	0,08	0,10	0,11	0,13	75	0,04	0,05	0,06	0,08	0,10	0,11	0,13
P.1.5	85	0,04	0,05	0,06	0,08	0,10	0,11	0,13	80	0,04	0,05	0,06	0,08	0,10	0,11	0,13
P.2.1	85	0,05	0,07	0,09	0,10	0,12	0,14	0,16	80	0,05	0,07	0,09	0,10	0,12	0,14	0,16
P.2.2	80	0,04	0,05	0,06	0,08	0,10	0,11	0,13	75	0,04	0,05	0,06	0,08	0,10	0,11	0,13
P.2.3	80	0,05	0,07	0,09	0,10	0,12	0,14	0,16	75	0,05	0,07	0,09	0,10	0,12	0,14	0,16
P.2.4	80	0,04	0,05	0,06	0,08	0,10	0,11	0,13	75	0,04	0,05	0,06	0,08	0,10	0,11	0,13
P.3.1	45	0,03	0,03	0,04	0,05	0,06	0,08	0,10	40	0,03	0,03	0,04	0,05	0,06	0,08	0,10
P.3.2	65	0,04	0,05	0,06	0,08	0,10	0,11	0,13	60	0,04	0,05	0,06	0,08	0,10	0,11	0,13
P.3.3	65	0,04	0,05	0,06	0,08	0,10	0,11	0,13	60	0,04	0,05	0,06	0,08	0,10	0,11	0,13
P.4.1	65	0,03	0,03	0,04	0,05	0,06	0,08	0,10	60	0,03	0,03	0,04	0,05	0,06	0,08	0,10
P.4.2	45	0,03	0,03	0,04	0,05	0,06	0,08	0,10	40	0,03	0,03	0,04	0,05	0,06	0,08	0,10
M.1.1	50	0,03	0,03	0,04	0,05	0,06	0,08	0,10	45	0,03	0,03	0,04	0,05	0,06	0,08	0,10
M.2.1	50	0,03	0,03	0,04	0,05	0,06	0,08	0,10	45	0,03	0,03	0,04	0,05	0,06	0,08	0,10
M.3.1	50	0,03	0,03	0,04	0,05	0,06	0,08	0,10	45	0,03	0,03	0,04	0,05	0,06	0,08	0,10
K.1.1	90	0,08	0,10	0,13	0,15	0,19	0,23	0,27	85	0,08	0,10	0,13	0,15	0,19	0,23	0,27
K.1.2	85	0,08	0,10	0,13	0,15	0,19	0,23	0,27	80	0,08	0,10	0,13	0,15	0,19	0,23	0,27
K.2.1	90	0,06	0,08	0,10	0,13	0,16	0,18	0,22	85	0,06	0,08	0,10	0,13	0,16	0,18	0,22
K.2.2	85	0,06	0,08	0,10	0,13	0,16	0,18	0,22	80	0,06	0,08	0,10	0,13	0,16	0,18	0,22
K.3.1	90	0,06	0,08	0,10	0,13	0,16	0,18	0,22	85	0,06	0,08	0,10	0,13	0,16	0,18	0,22
K.3.2	85	0,06	0,08	0,10	0,13	0,16	0,18	0,22	80	0,06	0,08	0,10	0,13	0,16	0,18	0,22
N.1.1																
N.1.2																
N.2.1																
N.2.2																
N.2.3																
N.3.1																
N.3.2																
N.3.3																
N.4.1																
S.1.1																
S.1.2																
S.2.1																
S.2.2																
S.2.3	65	0,04	0,05	0,06	0,08	0,10	0,11	0,13	60	0,04	0,05	0,06	0,08	0,10	0,11	0,13
S.3.1																
S.3.2																
S.3.3																
H.1.1																
H.1.2																
H.1.3																
H.1.4																
H.2.1																
H.3.1																
O.1.1																
O.1.2																
O.2.1																
O.2.2																
O.3.1																



The cutting data depends extremely on the external conditions, the material and machine type.
The indicated values are possible values which have to be increased or reduced according to the application conditions.

Index	11 040 ...							11 050 ...				
	with through coolant v _c (m/min)	40xD					with through coolant v _c (m/min)	50xD				
		Ø 3-4	Ø > 4-5	Ø > 5-6	Ø > 6-8	Ø > 8-10		Ø 3-4	Ø > 4-5	Ø > 5-6	Ø > 6-8	
		f (mm/rev)						f (mm/rev)				
P.1.1	70	0,05	0,06	0,08	0,10	0,11	70	0,05	0,06	0,08	0,10	
P.1.2	60	0,05	0,06	0,08	0,10	0,11	60	0,05	0,06	0,08	0,10	
P.1.3	60	0,03	0,04	0,05	0,06	0,08	60	0,03	0,04	0,05	0,06	
P.1.4	60	0,03	0,04	0,05	0,06	0,08	60	0,03	0,04	0,05	0,06	
P.1.5	65	0,03	0,04	0,05	0,06	0,08	65	0,03	0,04	0,05	0,06	
P.2.1	65	0,05	0,06	0,08	0,10	0,11	65	0,05	0,06	0,08	0,10	
P.2.2	60	0,03	0,04	0,05	0,06	0,08	60	0,03	0,04	0,05	0,06	
P.2.3	60	0,05	0,06	0,08	0,10	0,11	60	0,05	0,06	0,08	0,10	
P.2.4	60	0,03	0,04	0,05	0,06	0,08	60	0,03	0,04	0,05	0,06	
P.3.1	35	0,03	0,03	0,04	0,05	0,06	35	0,03	0,03	0,04	0,05	
P.3.2	50	0,03	0,04	0,05	0,06	0,08	50	0,03	0,04	0,05	0,06	
P.3.3	50	0,03	0,04	0,05	0,06	0,08	50	0,03	0,04	0,05	0,06	
P.4.1	50	0,03	0,03	0,04	0,05	0,06	50	0,03	0,03	0,04	0,05	
P.4.2	35	0,03	0,03	0,04	0,05	0,06	35	0,03	0,03	0,04	0,05	
M.1.1	40	0,03	0,03	0,04	0,05	0,06	40	0,03	0,03	0,04	0,05	
M.2.1	40	0,03	0,03	0,04	0,05	0,06	40	0,03	0,03	0,04	0,05	
M.3.1	40	0,03	0,03	0,04	0,05	0,06	40	0,03	0,03	0,04	0,05	
K.1.1	70	0,08	0,10	0,13	0,16	0,18	70	0,08	0,10	0,13	0,16	
K.1.2	65	0,08	0,10	0,13	0,16	0,18	65	0,08	0,10	0,13	0,16	
K.2.1	70	0,07	0,09	0,10	0,12	0,14	70	0,07	0,09	0,10	0,12	
K.2.2	65	0,07	0,09	0,10	0,12	0,14	65	0,07	0,09	0,10	0,12	
K.3.1	70	0,07	0,09	0,10	0,12	0,14	70	0,07	0,09	0,10	0,12	
K.3.2	65	0,07	0,09	0,10	0,12	0,14	65	0,07	0,09	0,10	0,12	
N.1.1												
N.1.2												
N.2.1												
N.2.2												
N.2.3												
N.3.1												
N.3.2												
N.3.3												
N.4.1												
S.1.1												
S.1.2												
S.2.1												
S.2.2												
S.2.3	50	0,03	0,04	0,05	0,06	0,08	50	0,03	0,04	0,05	0,06	
S.3.1												
S.3.2												
S.3.3												
H.1.1												
H.1.2												
H.1.3												
H.1.4												
H.2.1												
H.3.1												
O.1.1												
O.1.2												
O.2.1												
O.2.2												
O.3.1												



All solid carbide WTX deep hole drills must be used with a pilot bore. The tool must never be run at high speed while not engaged in a material. Please refer to the strategy for the production of deep holes on → Page 160.

Cutting data standard values – WTX – TB ALU

Index	11 017 ...								11 021 ...							
	with through coolant v_c (m/min)	16xD							with through coolant v_c (m/min)	20xD						
		\emptyset 2-3	\emptyset > 3-4	\emptyset > 4-5	\emptyset > 5-6	\emptyset > 6-8	\emptyset > 8-10	\emptyset > 10-12		\emptyset 2-3	\emptyset > 3-4	\emptyset > 4-5	\emptyset > 5-6	\emptyset > 6-8	\emptyset > 8-10	\emptyset > 10-12
f (mm/rev)								f (mm/rev)								
P.1.1																
P.1.2																
P.1.3																
P.1.4																
P.1.5																
P.2.1																
P.2.2																
P.2.3																
P.2.4																
P.3.1																
P.3.2																
P.3.3																
P.4.1																
P.4.2																
M.1.1																
M.2.1																
M.3.1																
K.1.1																
K.1.2																
K.2.1																
K.2.2																
K.3.1																
K.3.2																
N.1.1	160	0,06	0,08	0,10	0,13	0,16	0,18	0,22	150	0,06	0,08	0,10	0,13	0,16	0,18	0,22
N.1.2	180	0,06	0,08	0,10	0,13	0,16	0,18	0,22	170	0,06	0,08	0,10	0,13	0,16	0,18	0,22
N.2.1	160	0,08	0,11	0,13	0,15	0,19	0,23	0,26	150	0,08	0,11	0,13	0,15	0,19	0,23	0,26
N.2.2	190	0,08	0,11	0,13	0,15	0,19	0,23	0,26	180	0,08	0,11	0,13	0,15	0,19	0,23	0,26
N.2.3	140	0,06	0,08	0,10	0,13	0,16	0,18	0,22	130	0,06	0,08	0,10	0,13	0,16	0,18	0,22
N.3.1	115	0,06	0,08	0,10	0,13	0,16	0,18	0,22	100	0,06	0,08	0,10	0,13	0,16	0,18	0,22
N.3.2	115	0,06	0,08	0,10	0,13	0,16	0,18	0,22	100	0,06	0,08	0,10	0,13	0,16	0,18	0,22
N.3.3	90	0,06	0,08	0,10	0,13	0,16	0,18	0,22	80	0,06	0,08	0,10	0,13	0,16	0,18	0,22
N.4.1																
S.1.1																
S.1.2																
S.2.1																
S.2.2																
S.2.3																
S.3.1																
S.3.2																
S.3.3																
H.1.1																
H.1.2																
H.1.3																
H.1.4																
H.2.1																
H.3.1																
O.1.1																
O.1.2																
O.2.1																
O.2.2																
O.3.1																



The cutting data depends extremely on the external conditions, the material and machine type.
The indicated values are possible values which have to be increased or reduced according to the application conditions.

Index	11 026 ...									11 031 ...							
	with through coolant v _c (m/min)	25xD							with through coolant v _c (m/min)	30xD							
		∅ 2-3	∅ >3-4	∅ >4-5	∅ >5-6	∅ >6-8	∅ >8-10	∅ >10-12		∅ 2-3	∅ >3-4	∅ >4-5	∅ >5-6	∅ >6-8	∅ >8-10	∅ >10-12	
f (mm/rev)									f (mm/rev)								
P.1.1																	
P.1.2																	
P.1.3																	
P.1.4																	
P.1.5																	
P.2.1																	
P.2.2																	
P.2.3																	
P.2.4																	
P.3.1																	
P.3.2																	
P.3.3																	
P.4.1																	
P.4.2																	
M.1.1																	
M.2.1																	
M.3.1																	
K.1.1																	
K.1.2																	
K.2.1																	
K.2.2																	
K.3.1																	
K.3.2																	
N.1.1	130	0,06	0,08	0,10	0,13	0,16	0,18	0,22	120	0,04	0,05	0,07	0,08	0,12	0,15	0,18	
N.1.2	150	0,06	0,08	0,10	0,13	0,16	0,18	0,22	140	0,04	0,05	0,07	0,08	0,12	0,15	0,18	
N.2.1	130	0,08	0,11	0,13	0,15	0,19	0,23	0,26	120	0,08	0,11	0,13	0,15	0,19	0,23	0,26	
N.2.2	160	0,08	0,11	0,13	0,15	0,19	0,23	0,26	150	0,08	0,11	0,13	0,15	0,19	0,23	0,26	
N.2.3	120	0,06	0,08	0,10	0,13	0,16	0,18	0,22	110	0,04	0,05	0,07	0,08	0,12	0,15	0,18	
N.3.1	90	0,06	0,08	0,10	0,13	0,16	0,18	0,22	80	0,04	0,05	0,07	0,08	0,12	0,15	0,18	
N.3.2	90	0,06	0,08	0,10	0,13	0,16	0,18	0,22	80	0,04	0,05	0,07	0,08	0,12	0,15	0,18	
N.3.3	75	0,06	0,08	0,10	0,13	0,16	0,18	0,22	70	0,01	0,01	0,02	0,02	0,03	0,04	0,05	
N.4.1																	
S.1.1																	
S.1.2																	
S.2.1																	
S.2.2																	
S.2.3																	
S.3.1																	
S.3.2																	
S.3.3																	
H.1.1																	
H.1.2																	
H.1.3																	
H.1.4																	
H.2.1																	
H.3.1																	
O.1.1																	
O.1.2																	
O.2.1																	
O.2.2																	
O.3.1																	



All solid carbide WTX deep hole drills must be used with a pilot bore. The tool must never be run at high speed while not engaged in a material. Please refer to the strategy for the production of deep holes on → Page 160.

		10 702 ..., 10 703 ..., 10 704 ...											
Index	without through coolant v _c (m/min)	NC-A											
		Ø 2-3	Ø 3-4	Ø 4-5	Ø 5-6	Ø 6-8	Ø 8-10	Ø 10-12	Ø 12-14	Ø 14-16	Ø 16-18	Ø 18-20	
		f (mm/rev)											
P.1.1	75	0,05	0,07	0,08	0,10	0,12	0,14	0,16	0,20	0,24	0,28	0,31	
P.1.2	65	0,05	0,07	0,08	0,10	0,12	0,14	0,16	0,20	0,24	0,28	0,31	
P.1.3	65	0,04	0,05	0,06	0,08	0,10	0,11	0,13	0,15	0,18	0,20	0,23	
P.1.4	65	0,04	0,05	0,06	0,08	0,10	0,11	0,13	0,15	0,18	0,20	0,23	
P.1.5	70	0,04	0,05	0,06	0,08	0,10	0,11	0,13	0,15	0,18	0,20	0,23	
P.2.1	70	0,05	0,07	0,08	0,10	0,12	0,14	0,16	0,20	0,24	0,28	0,31	
P.2.2	65	0,04	0,05	0,06	0,08	0,10	0,11	0,13	0,15	0,18	0,20	0,23	
P.2.3	65	0,05	0,07	0,08	0,10	0,12	0,14	0,16	0,20	0,24	0,28	0,31	
P.2.4	65	0,04	0,05	0,06	0,08	0,10	0,11	0,13	0,15	0,18	0,20	0,23	
P.3.1													
P.3.2													
P.3.3													
P.4.1													
P.4.2													
M.1.1													
M.2.1													
M.3.1													
K.1.1	70	0,04	0,05	0,06	0,08	0,10	0,13	0,15	0,18	0,20	0,23	0,27	
K.1.2	70	0,04	0,05	0,06	0,08	0,10	0,11	0,13	0,15	0,18	0,20	0,23	
K.2.1	70	0,04	0,05	0,06	0,08	0,10	0,11	0,13	0,15	0,18	0,20	0,23	
K.2.2	70	0,04	0,05	0,06	0,08	0,10	0,11	0,13	0,15	0,18	0,20	0,23	
K.3.1	70	0,04	0,05	0,06	0,08	0,10	0,11	0,13	0,15	0,18	0,20	0,23	
K.3.2	70	0,04	0,05	0,06	0,08	0,10	0,11	0,13	0,15	0,18	0,20	0,23	
N.1.1	200	0,01	0,01	0,02	0,02	0,03	0,04	0,05	0,07	0,09	0,11	0,13	
N.1.2	200	0,01	0,01	0,02	0,02	0,03	0,04	0,05	0,07	0,09	0,11	0,13	
N.2.1	160	0,01	0,01	0,02	0,02	0,03	0,04	0,05	0,07	0,09	0,11	0,13	
N.2.2	180	0,01	0,01	0,02	0,02	0,03	0,04	0,05	0,07	0,09	0,11	0,13	
N.2.3	130	0,01	0,01	0,02	0,02	0,03	0,04	0,05	0,07	0,09	0,11	0,13	
N.3.1	160	0,01	0,01	0,01	0,01	0,02	0,03	0,04	0,06	0,09	0,11	0,14	
N.3.2	160	0,01	0,01	0,01	0,01	0,02	0,03	0,04	0,06	0,09	0,11	0,14	
N.3.3	100	0,01	0,01	0,01	0,01	0,02	0,03	0,04	0,06	0,09	0,11	0,14	
N.4.1													
S.1.1													
S.1.2													
S.2.1													
S.2.2													
S.2.3													
S.3.1													
S.3.2													
S.3.3													
H.1.1													
H.1.2													
H.1.3													
H.1.4													
H.2.1													
H.3.1													
O.1.1													
O.1.2													
O.2.1													
O.2.2													
O.3.1													

Cutting data standard values – Solid Carbide NC-A TiAlN

Index	10 716 ..., 10 717 ..., 10 718 ...											
	NC-A TiAlN											
	without through coolant v _c (m/min)	Ø 2-3	Ø 3-4	Ø 4-5	Ø 5-6	Ø 6-8	Ø 8-10	Ø 10-12	Ø 12-14	Ø 14-16	Ø 16-18	Ø 18-20
	f (mm/rev)											
P.1.1	75	0,05	0,07	0,08	0,10	0,12	0,14	0,16	0,20	0,24	0,28	0,31
P.1.2	65	0,05	0,07	0,08	0,10	0,12	0,14	0,16	0,20	0,24	0,28	0,31
P.1.3	65	0,04	0,05	0,06	0,08	0,10	0,11	0,13	0,15	0,18	0,20	0,23
P.1.4	65	0,04	0,05	0,06	0,08	0,10	0,11	0,13	0,15	0,18	0,20	0,23
P.1.5	70	0,04	0,05	0,06	0,08	0,10	0,11	0,13	0,15	0,18	0,20	0,23
P.2.1	70	0,05	0,07	0,08	0,10	0,12	0,14	0,16	0,20	0,24	0,28	0,31
P.2.2	65	0,04	0,05	0,06	0,08	0,10	0,11	0,13	0,15	0,18	0,20	0,23
P.2.3	65	0,05	0,07	0,08	0,10	0,12	0,14	0,16	0,20	0,24	0,28	0,31
P.2.4	65	0,04	0,05	0,06	0,08	0,10	0,11	0,13	0,15	0,18	0,20	0,23
P.3.1												
P.3.2												
P.3.3												
P.4.1												
P.4.2												
M.1.1												
M.2.1												
M.3.1												
K.1.1	70	0,04	0,05	0,06	0,08	0,10	0,13	0,15	0,18	0,20	0,23	0,26
K.1.2	70	0,04	0,05	0,06	0,08	0,10	0,11	0,13	0,15	0,18	0,20	0,23
K.2.1	70	0,04	0,05	0,06	0,08	0,10	0,11	0,13	0,15	0,18	0,20	0,23
K.2.2	70	0,04	0,05	0,06	0,08	0,10	0,11	0,13	0,15	0,18	0,20	0,23
K.3.1	70	0,04	0,05	0,06	0,08	0,10	0,11	0,13	0,15	0,18	0,20	0,23
K.3.2	70	0,04	0,05	0,06	0,08	0,10	0,11	0,13	0,15	0,18	0,20	0,23
N.1.1	200	0,01	0,01	0,02	0,02	0,03	0,04	0,05	0,07	0,09	0,11	0,13
N.1.2	200	0,01	0,01	0,02	0,02	0,03	0,04	0,05	0,07	0,09	0,11	0,13
N.2.1	160	0,01	0,01	0,02	0,02	0,03	0,04	0,05	0,07	0,09	0,11	0,13
N.2.2	180	0,01	0,01	0,02	0,02	0,03	0,04	0,05	0,07	0,09	0,11	0,13
N.2.3	130	0,01	0,01	0,02	0,02	0,03	0,04	0,05	0,07	0,09	0,11	0,13
N.3.1	160	0,01	0,01	0,01	0,01	0,02	0,03	0,04	0,06	0,09	0,11	0,14
N.3.2	160	0,01	0,01	0,01	0,01	0,02	0,03	0,04	0,06	0,09	0,11	0,14
N.3.3	100	0,01	0,01	0,01	0,01	0,02	0,03	0,04	0,06	0,09	0,11	0,14
N.4.1												
S.1.1												
S.1.2												
S.2.1												
S.2.2												
S.2.3												
S.3.1												
S.3.2												
S.3.3												
H.1.1	28	0,02	0,03	0,04	0,04	0,05	0,06	0,06	0,07	0,07	0,08	0,08
H.1.2	16	0,02	0,03	0,04	0,04	0,05	0,06	0,06	0,07	0,07	0,08	0,08
H.1.3												
H.1.4												
H.2.1												
H.3.1												
O.1.1												
O.1.2												
O.2.1												
O.2.2												
O.3.1												



The cutting data is highly dependent on external conditions, such as stability of the tool and workpiece clamping, material and machine type!
The values indicated represent possible cutting data which may need to be corrected depending on operating conditions !

Index	10 724 ..., 10 726 ..., 10 727 ...									
	NC-A TiAlN									
	without through coolant v _c (m/min)	Ø 3-4	Ø 4-5	Ø 5-6	Ø 6-8	Ø 8-10	Ø 10-12	Ø 12-14	Ø 14-16	
	f (mm/rev)									
P.1.1	75	0,07	0,08	0,10	0,12	0,14	0,16	0,20	0,24	
P.1.2	65	0,07	0,08	0,10	0,12	0,14	0,16	0,20	0,24	
P.1.3	65	0,05	0,06	0,08	0,10	0,11	0,13	0,15	0,18	
P.1.4	65	0,05	0,06	0,08	0,10	0,11	0,13	0,15	0,18	
P.1.5	70	0,05	0,06	0,08	0,10	0,11	0,13	0,15	0,18	
P.2.1	70	0,07	0,08	0,10	0,12	0,14	0,16	0,20	0,24	
P.2.2	65	0,05	0,06	0,08	0,10	0,11	0,13	0,15	0,18	
P.2.3	65	0,07	0,08	0,10	0,12	0,14	0,16	0,20	0,24	
P.2.4	65	0,05	0,06	0,08	0,10	0,11	0,13	0,15	0,18	
P.3.1										
P.3.2										
P.3.3										
P.4.1										
P.4.2										
M.1.1										
M.2.1										
M.3.1										
K.1.1	70	0,05	0,06	0,08	0,10	0,13	0,15	0,18	0,20	
K.1.2	70	0,05	0,06	0,08	0,10	0,11	0,13	0,15	0,18	
K.2.1	70	0,05	0,06	0,08	0,10	0,11	0,13	0,15	0,18	
K.2.2	70	0,05	0,06	0,08	0,10	0,11	0,13	0,15	0,18	
K.3.1	70	0,05	0,06	0,08	0,10	0,11	0,13	0,15	0,18	
K.3.2	70	0,05	0,06	0,08	0,10	0,11	0,13	0,15	0,18	
N.1.1	200	0,01	0,02	0,02	0,03	0,04	0,05	0,07	0,09	
N.1.2	200	0,01	0,02	0,02	0,03	0,04	0,05	0,07	0,09	
N.2.1	160	0,01	0,02	0,02	0,03	0,04	0,05	0,07	0,09	
N.2.2	180	0,01	0,02	0,02	0,03	0,04	0,05	0,07	0,09	
N.2.3	130	0,01	0,02	0,02	0,03	0,04	0,05	0,07	0,09	
N.3.1	160	0,01	0,01	0,01	0,02	0,03	0,04	0,06	0,09	
N.3.2	160	0,01	0,01	0,01	0,02	0,03	0,04	0,06	0,09	
N.3.3	100	0,01	0,01	0,01	0,02	0,03	0,04	0,06	0,09	
N.4.1										
S.1.1										
S.1.2										
S.2.1										
S.2.2										
S.2.3										
S.3.1										
S.3.2										
S.3.3										
H.1.1	30	0,03	0,04	0,04	0,05	0,06	0,06	0,07	0,07	
H.1.2	15	0,03	0,04	0,04	0,05	0,06	0,06	0,07	0,07	
H.1.3										
H.1.4										
H.2.1										
H.3.1										
O.1.1										
O.1.2										
O.2.1										
O.2.2										
O.3.1										

Cutting data standard values – WTX – Change

Index	10 919 ...					
	v _c (m/min)	UNI				
		≥ Ø 12–15,7	> Ø 15,7–20	> Ø 20–25	> Ø 25–32	> Ø 32–41
		f (mm/rev)				
P.1.1	120	0,27	0,31	0,34	0,36	0,36
P.1.2	115	0,26	0,30	0,32	0,34	0,35
P.1.3	110	0,25	0,28	0,31	0,32	0,33
P.1.4	105	0,24	0,27	0,29	0,31	0,31
P.1.5	100	0,22	0,25	0,28	0,29	0,30
P.2.1	120	0,32	0,37	0,40	0,42	0,43
P.2.2	110	0,29	0,33	0,36	0,38	0,39
P.2.3	100	0,26	0,30	0,33	0,35	0,35
P.2.4	75	0,23	0,26	0,29	0,30	0,31
P.3.1	85	0,26	0,30	0,33	0,35	0,35
P.3.2	65	0,22	0,25	0,27	0,28	0,29
P.3.3	65	0,17	0,19	0,21	0,22	0,22
P.4.1	65	0,17	0,20	0,22	0,23	0,23
P.4.2	65	0,17	0,20	0,22	0,23	0,23
M.1.1						
M.2.1						
M.3.1						
K.1.1	110	0,37	0,42	0,46	0,49	0,50
K.1.2	90	0,29	0,33	0,36	0,38	0,39
K.2.1	145	0,34	0,39	0,42	0,45	0,46
K.2.2	90	0,29	0,33	0,36	0,38	0,39
K.3.1	80	0,35	0,40	0,44	0,46	0,47
K.3.2	70	0,28	0,32	0,34	0,36	0,37
N.1.1						
N.1.2						
N.2.1						
N.2.2						
N.2.3						
N.3.1						
N.3.2						
N.3.3						
N.4.1						
S.1.1						
S.1.2						
S.2.1						
S.2.2						
S.2.3						
S.3.1						
S.3.2						
S.3.3						
H.1.1						
H.1.2						
H.1.3						
H.1.4						
H.2.1						
H.3.1						
O.1.1						
O.1.2						
O.2.1						
O.2.2						
O.3.1						



The cutting data is highly dependent on external conditions, such as stability of the tool and workpiece clamping, material and machine type!
The values indicated represent possible cutting data which may need to be corrected depending on operating conditions !

		10 923 ...				
Index	v _c (m/min)	P				
		≥ Ø 12–15,7	> Ø 15,7–20	> Ø 20–25	> Ø 25–32	> Ø 32–41
		f (mm/rev)				
P.1.1	120	0,32	0,36	0,39	0,41	0,42
P.1.2	115	0,30	0,34	0,37	0,39	0,40
P.1.3	110	0,29	0,32	0,35	0,37	0,38
P.1.4	105	0,27	0,31	0,34	0,35	0,36
P.1.5	100	0,26	0,29	0,32	0,34	0,34
P.2.1	120	0,37	0,42	0,46	0,49	0,49
P.2.2	110	0,34	0,38	0,42	0,44	0,45
P.2.3	100	0,30	0,35	0,38	0,40	0,40
P.2.4	75	0,27	0,30	0,33	0,35	0,35
P.3.1	85	0,30	0,35	0,38	0,40	0,40
P.3.2	65	0,25	0,28	0,31	0,32	0,33
P.3.3	65	0,19	0,22	0,24	0,25	0,25
P.4.1	65	0,20	0,23	0,25	0,26	0,27
P.4.2	65	0,20	0,23	0,25	0,26	0,27
M.1.1						
M.2.1						
M.3.1						
K.1.1	110	0,41	0,47	0,51	0,54	0,55
K.1.2	90	0,33	0,37	0,41	0,43	0,43
K.2.1	145	0,38	0,43	0,47	0,50	0,51
K.2.2	90	0,33	0,37	0,41	0,43	0,43
K.3.1	80	0,35	0,40	0,44	0,46	0,47
K.3.2	70	0,28	0,32	0,34	0,36	0,37
N.1.1						
N.1.2						
N.2.1						
N.2.2						
N.2.3						
N.3.1						
N.3.2						
N.3.3						
N.4.1						
S.1.1						
S.1.2						
S.2.1						
S.2.2						
S.2.3						
S.3.1						
S.3.2						
S.3.3						
H.1.1						
H.1.2						
H.1.3						
H.1.4						
H.2.1						
H.3.1						
O.1.1						
O.1.2						
O.2.1						
O.2.2						
O.3.1						



For through holes, the feed must be reduced by approx. 30% when exiting the hole. For more accurate positioning, precentre with a 142° NC spot drill. With Type VA 5xD and 8xD, enter the hole with reduced feed of 0.05 – 0.06 mm/revolution.

Cutting data standard values – WTX – Change

Index	10 921 ...					10 924 ...				
	VA					GG				
	v _c (m/min)	≥ Ø 12–15,7	> Ø 15,7–20	> Ø 20–25	> Ø 25–32	v _c (m/min)	≥ Ø 12–15,7	> Ø 15,7–20	> Ø 20–25	> Ø 25–32
		f (mm/rev)					f (mm/rev)			
P.1.1	110	0,25	0,28	0,30	0,32					
P.1.2	105	0,24	0,27	0,29	0,31					
P.1.3	100	0,22	0,25	0,28	0,29					
P.1.4	95	0,21	0,24	0,26	0,28					
P.1.5	90	0,20	0,23	0,25	0,26					
P.2.1	110	0,29	0,33	0,36	0,38					
P.2.2	100	0,26	0,30	0,33	0,35					
P.2.3	90	0,24	0,27	0,29	0,31					
P.2.4	70	0,21	0,24	0,26	0,27					
P.3.1	75	0,24	0,27	0,30	0,31					
P.3.2	60	0,19	0,22	0,24	0,25					
P.3.3	60	0,15	0,17	0,18	0,19					
P.4.1	60	0,16	0,18	0,19	0,20					
P.4.2	60	0,16	0,18	0,19	0,20					
M.1.1	55	0,20	0,23	0,25	0,26					
M.2.1	50	0,17	0,19	0,21	0,22					
M.3.1	50	0,17	0,19	0,21	0,22					
K.1.1	95	0,37	0,42	0,46	0,49	120	0,49	0,56	0,62	0,65
K.1.2	80	0,29	0,33	0,36	0,38	100	0,39	0,45	0,49	0,51
K.2.1	130	0,34	0,39	0,42	0,45	160	0,45	0,52	0,57	0,60
K.2.2	80	0,29	0,33	0,36	0,38	100	0,39	0,45	0,49	0,51
K.3.1	70	0,32	0,36	0,39	0,41	90	0,42	0,48	0,52	0,55
K.3.2	65	0,25	0,28	0,31	0,33	80	0,34	0,38	0,41	0,44
N.1.1										
N.1.2										
N.2.1										
N.2.2										
N.2.3										
N.3.1										
N.3.2										
N.3.3										
N.4.1										
S.1.1	30	0,14	0,16	0,17	0,18					
S.1.2	20	0,10	0,11	0,12	0,13					
S.2.1	20	0,10	0,11	0,12	0,13					
S.2.2	15	0,12	0,14	0,15	0,16					
S.2.3	15	0,10	0,11	0,12	0,13					
S.3.1	40	0,17	0,20	0,22	0,23					
S.3.2	30	0,15	0,17	0,18	0,19					
S.3.3	25	0,12	0,14	0,15	0,16					
H.1.1										
H.1.2										
H.1.3										
H.1.4										
H.2.1										
H.3.1										
O.1.1										
O.1.2										
O.2.1										
O.2.2										
O.3.1										



The cutting data is highly dependent on external conditions, such as stability of the tool and workpiece clamping, material and machine type!
The values indicated represent possible cutting data which may need to be corrected depending on operating conditions !

Index	10 922 ...				
	AL				
	v _c (m/min)	≥ Ø 12–15,7	> Ø 15,7–20	> Ø 20–25	> Ø 25–32
f (mm/rev)					
P.1.1					
P.1.2					
P.1.3					
P.1.4					
P.1.5					
P.2.1					
P.2.2					
P.2.3					
P.2.4					
P.3.1					
P.3.2					
P.3.3					
P.4.1					
P.4.2					
M.1.1					
M.2.1					
M.3.1					
K.1.1					
K.1.2					
K.2.1					
K.2.2					
K.3.1					
K.3.2					
N.1.1	330	0,27	0,31	0,34	0,36
N.1.2	300	0,25	0,28	0,31	0,32
N.2.1	250	0,33	0,37	0,41	0,43
N.2.2	220	0,33	0,37	0,41	0,43
N.2.3	180	0,33	0,37	0,41	0,43
N.3.1	200	0,41	0,47	0,51	0,54
N.3.2	120	0,33	0,37	0,41	0,43
N.3.3	140	0,25	0,28	0,31	0,32
N.4.1					
S.1.1					
S.1.2					
S.2.1					
S.2.2					
S.2.3					
S.3.1					
S.3.2					
S.3.3					
H.1.1					
H.1.2					
H.1.3					
H.1.4					
H.2.1					
H.3.1					
O.1.1					
O.1.2					
O.2.1					
O.2.2					
O.3.1					



With through-holes the feedrate should be reduced at the break out by approx. 30 %. Use 142° NC Spot Drill to ensure positional accuracy. Use reduced feedrate of 0.05 – 0.06 mm/U when using type VA 5xD and 8xD drill.

Cutting data standard values – WTX – Change Feed

Index	10 925 ...							
	UNI							
	with through coolant	With external coolant v_c (m/min)	MMS	$\geq \varnothing 14,0$	$> \varnothing 17,5$	$> \varnothing 21,5$	$> \varnothing 26,0$	$\varnothing 32,0$
	f (mm/rev)							
P.1.1	100	90	90	0,45	0,51	0,55	0,58	0,60
P.1.2	95	85	85	0,43	0,48	0,53	0,55	0,57
P.1.3	90	80	80	0,41	0,46	0,50	0,53	0,54
P.1.4	85	75	75	0,39	0,44	0,48	0,50	0,51
P.1.5	80	75	75	0,37	0,42	0,45	0,47	0,49
P.2.1	100	85	85	0,54	0,60	0,65	0,69	0,71
P.2.2	90	75	75	0,49	0,55	0,59	0,62	0,64
P.2.3	80	70	70	0,44	0,49	0,53	0,56	0,58
P.2.4	65	55	55	0,39	0,43	0,47	0,49	0,51
P.3.1	70	60	60	0,44	0,49	0,53	0,56	0,58
P.3.2	55	50	50	0,36	0,40	0,43	0,46	0,47
P.3.3	55	40	45	0,28	0,31	0,33	0,35	0,36
P.4.1	55	40	45	0,29	0,32	0,35	0,37	0,38
P.4.2	55	40	45	0,29	0,32	0,35	0,37	0,38
M.1.1								
M.2.1								
M.3.1								
K.1.1	110	75	75	0,68	0,77	0,83	0,88	0,90
K.1.2	90	70	70	0,54	0,61	0,66	0,69	0,71
K.2.1	145	90	110	0,63	0,71	0,77	0,81	0,83
K.2.2	90	70	70	0,54	0,61	0,66	0,69	0,71
K.3.1	80	70	70	0,58	0,65	0,71	0,75	0,77
K.3.2	70	65	65	0,46	0,52	0,56	0,59	0,61
N.1.1								
N.1.2								
N.2.1								
N.2.2								
N.2.3								
N.3.1								
N.3.2								
N.3.3								
N.4.1								
S.1.1								
S.1.2								
S.2.1								
S.2.2								
S.2.3								
S.3.1								
S.3.2								
S.3.3								
H.1.1								
H.1.2								
H.1.3								
H.1.4								
H.2.1								
H.3.1								
O.1.1								
O.1.2								
O.2.1								
O.2.2								
O.3.1								



The cutting data is highly dependent on external conditions, such as stability of the tool and workpiece clamping, material and machine type!
The values indicated represent possible cutting data which may need to be corrected depending on operating conditions !

Cutting data standard values – WPC – Change

Index	11 910 ...				
	UNI				
	v _c (m/min)	Ø 14–16	> Ø 16–20	> Ø 20–25	> Ø 25–30
		f (mm/rev)			
P.1.1	100	0,22	0,25	0,28	0,32
P.1.2	100	0,27	0,31	0,35	0,39
P.1.3	100	0,27	0,31	0,35	0,39
P.1.4	90	0,25	0,28	0,32	0,35
P.1.5	90	0,25	0,28	0,32	0,35
P.2.1	100	0,25	0,28	0,32	0,35
P.2.2	100	0,25	0,28	0,32	0,35
P.2.3	100	0,25	0,28	0,32	0,35
P.2.4	80	0,21	0,24	0,27	0,30
P.3.1	70	0,20	0,22	0,25	0,28
P.3.2	70	0,18	0,21	0,24	0,26
P.3.3	60	0,17	0,19	0,22	0,24
P.4.1	55	0,17	0,19	0,22	0,24
P.4.2	55	0,17	0,19	0,22	0,24
M.1.1					
M.2.1					
M.3.1					
K.1.1	110	0,37	0,42	0,47	0,53
K.1.2	100	0,31	0,35	0,39	0,44
K.2.1	100	0,37	0,42	0,47	0,53
K.2.2	90	0,31	0,35	0,39	0,44
K.3.1	100	0,37	0,42	0,47	0,53
K.3.2	90	0,31	0,35	0,39	0,44
N.1.1					
N.1.2					
N.2.1					
N.2.2					
N.2.3					
N.3.1					
N.3.2					
N.3.3					
N.4.1					
S.1.1					
S.1.2					
S.2.1					
S.2.2					
S.2.3					
S.3.1					
S.3.2					
S.3.3					
H.1.1					
H.1.2					
H.1.3					
H.1.4					
H.2.1					
H.3.1					
O.1.1					
O.1.2					
O.2.1					
O.2.2					
O.3.1					





























The cutting data is highly dependent on external conditions, such as stability of the tool and workpiece clamping, material and machine type!
The values indicated represent possible cutting data which may need to be corrected depending on operating conditions !

Type overview – WTX High performance drilling tools

- ▲ good self-centring
- ▲ optimum swarf control
- ▲ precise radial run-out
- ▲ excellent alignment precision
- ▲ high-quality surface finish
- ▲ close drilling tolerances
- ▲ limited hardening of peripheral zones of the material
- ▲ good chip evacuation even with large drilling depths

 For all products that are marked with the video icon, a relevant product video can be viewed at cuttingtools.uk/type-overview-wtx/



UNI		<ul style="list-style-type: none"> ▲ high-performance solid carbide drill for universal application, for all materials up to 1200 N/mm² 	DRAGONSKIN	
Feed UNI		<ul style="list-style-type: none"> ▲ solid carbide high feed drills with 3 cutting edges ▲ very good positional accuracy 	DRAGONSKIN	
Speed UNI		<ul style="list-style-type: none"> ▲ for double the cutting speed ▲ asymmetric point geometry permits performance improvement when drilling steel and cast iron by up to 60 % 	DRAGONSKIN	
Quattro 4F		<ul style="list-style-type: none"> ▲ with additional guide land for best alignment accuracy, concentricity and positional accuracy 	DRAGONSKIN	
180		<ul style="list-style-type: none"> ▲ for inclined surfaces up to 45° and flat bottom holes 		
TB		<ul style="list-style-type: none"> ▲ solid carbide deep hole drill, up to 50xD without peck drilling ▲ 4 or 6 facet head geometry for excellent alignment accuracy 		
CP		<ul style="list-style-type: none"> ▲ Ensures an even safer deep hole drilling process ▲ For optimal guidance of the deep hole twist drill for hole depths > 30xD 		
VA		<ul style="list-style-type: none"> ▲ first choice for corrosion and acid resistant steels ▲ for volume production 		
AL		<ul style="list-style-type: none"> ▲ solid carbide high performance drill specially for the machining of aluminium, copper and brass ▲ 6 facet geometry for excellent hole quality 	DRAGONSKIN	
Ti		<ul style="list-style-type: none"> ▲ Specialist for the cost-effective machining of titanium, titanium alloys and heat-resistant alloys ▲ Also suitable for machining corrosion-resistant and acid-resistant steels 	DRAGONSKIN	
H		<ul style="list-style-type: none"> ▲ high-performance drill for hardened steels from 45 to 70 HRC 	DRAGONSKIN	
HFDS		<ul style="list-style-type: none"> ▲ Four fluted high-feed drill ▲ Specially designed for steel processing ▲ Innovative cutting edge geometry guarantees high positioning accuracy 	DRAGONSKIN	
MINI		<ul style="list-style-type: none"> ▲ solid carbide micro drill for the precise manufacture of very small holes from Ø 0.1 to 2.9 mm 		
MICRO		<ul style="list-style-type: none"> ▲ Universal high-performance micro drill ▲ Specialised geometry and coating ▲ Pilot drill for WTX Micro deep hole twist drill 	DRAGONSKIN	
Change		<ul style="list-style-type: none"> ▲ replaceable head drills with the performance level of a solid carbide drill, from Ø 12.0 mm to 41.0 mm 		
Change Feed		<ul style="list-style-type: none"> ▲ exchangeable head drill with three cutting edges for even greater performance, from Ø 14.0 mm to 32.0 mm 		
Feed BR		<ul style="list-style-type: none"> ▲ Solid carbide high-performance drill reamer ▲ Drilling and reaming in one operation ▲ Three drilling edges and six reaming edges 	DRAGONSKIN	
SB		<ul style="list-style-type: none"> ▲ Solid carbide short step drill for steels and cast iron materials ▲ For core hole plus countersink for thread cutting and forming 	DRAGONSKIN	

Important application criteria for WTX drills

Offset

The axial run-out of the axis between a rotating work piece and a stationary tool must not exceed 0.04 mm. A larger run-out reduces tool life and drilling quality and can lead to tool breakage.

Run-out

The concentricity error when the tool is rotating should not exceed 0.015 mm.

Cooling lubricant

With internally cooled tools the coolant pressure should be min. 20 bar.

High-quality semi-synthetic or emulsion coolants with min. 10 % oil content and EP additives are recommended. This allows better life, and achieves higher tolerance accuracy and better surface quality. A fine filter system is recommended to prevent possible clogging of the coolant channels.

Drilling into full material

Due to the geometric design of the solid carbide drills, they are suitable for drilling into solid material.

With solid carbide drills $\leq 12xD$ drilling can be carried out in solid material without the need for centering and spot drilling operations.

Flute run-out

When using WTX drills a safety margin of at least 1 to 1.5 x D must be maintained between the work piece and the flute outlet groove of the drill to ensure optimum chip evacuation and prevent chip clogging and tool fracture.

Peck drilling

Pecking should be avoided as there is a very high risk of fracture caused by chips left behind or flushed into the hole.

Secondary tools

If a smaller diameter WTX drill is used as a following tool in the same hole, it should have a smaller drill point angle to ensure that it centres properly.

Interrupted cut

Reduce the feedrate on entry to and from cross holes

Drill exit

To avoid severe burr formation, reduce v_c and f .

Workpiece clamping

To avoid tool breakages, care must be taken to ensure a proper workpiece clamping without vibration or workpiece deflection.

Tool Clamping

With optimum clamping high alignment accuracy and tolerances (IT7-8) are possible.

Due to the high surface quality reaming operations can often be dispensed with.

Machine Requirements

Please note the performance diagram

Cutting data table

To control the chip length (comma chip) the feed rates should be no lower than the lower limits quoted in the cutting data table.

Feed rate f in mm/rev.

Drilling capacity relative to the diameter: $v_c = 80$ m/min.

Tensile strength of the material = 600 N/mm²

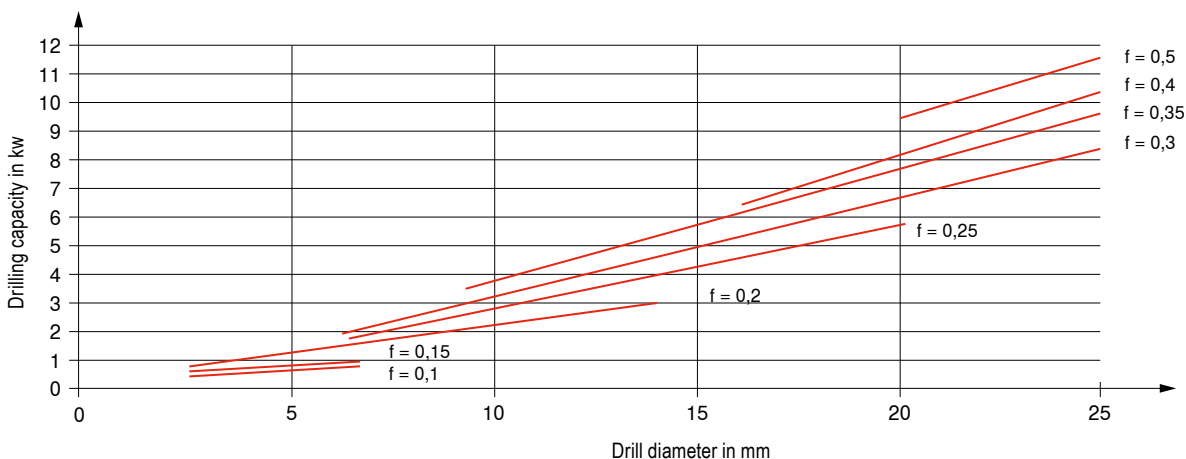

Strategy for the production of deep holes with the WTX solid carbide deep hole drill

1 Producing the pilot hole

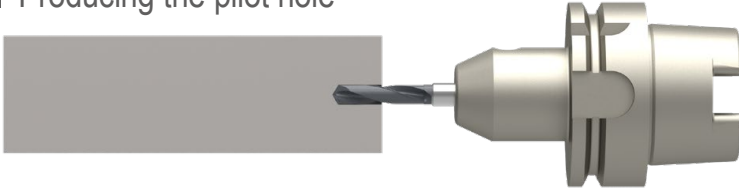

- ▲ For the pilot hole, we recommend a WTX drill 3xD/ 5xD with the same nominal diameter
- ▲ The pilot hole should be 0.01–0.03 mm larger in diameter and at least 3xD deep.
- ▲ It is essential to ensure that the point angle of the pilot drill is bigger than the point angle of the deep hole drill.
- ▲ From a hole depth of 40xD, we recommend a pilot hole with our Co-Pilot deep hole twist drill CP 20 UNI.

2 Movement of the deep hole drill into the pilot hole

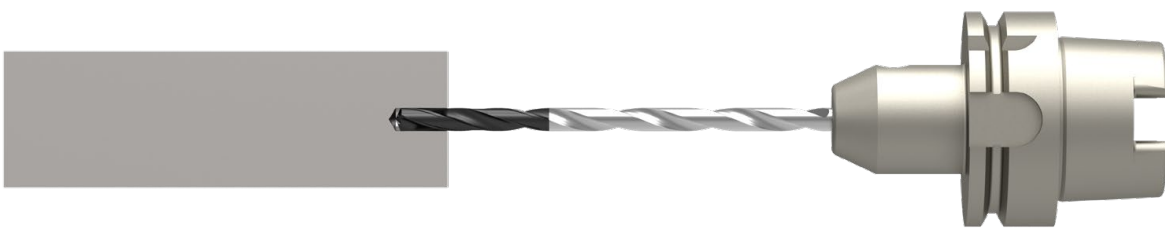

- ▲ Move the WTX deep hole drill without coolant pressure and with reduced speed ($n = 200\text{--}300$ 1/min) into the pilot hole at a feed of $v_f = 1.000$ mm/min
- ▲ Approx. 2 mm before reaching the bottom of the hole (end of the pilot hole), stop the feed, switch on the coolant and wait for a short time until the recommended pressure is reached. Then increase the spindle speed to the recommended speed as smoothly as possible.

3 Drilling to required depth without pecking

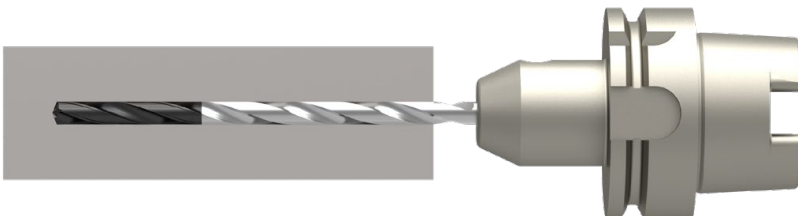

- ▲ Reduce feed rate for cross holes and at drill exit by 50%

4 Retracting the drill

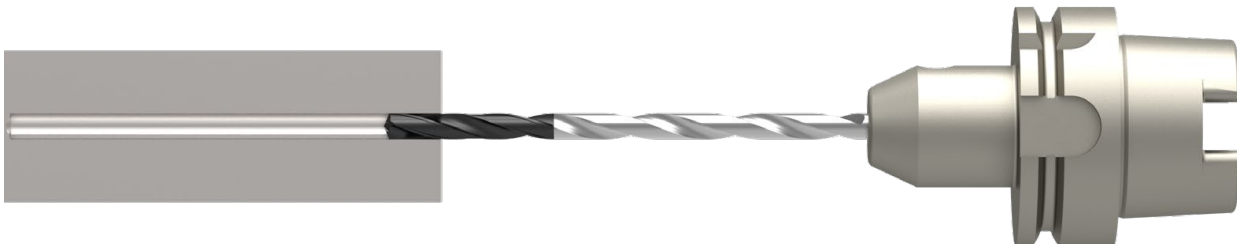

- ▲ Retract the drill to approximately the depth of the pilot hole.
- ▲ Reduce the rpm to a low speed ($n = 200\text{--}300$ 1/min).
- ▲ Use normal rapid feed ($V_f = 3.000$ mm/min) when exiting the hole.



For horizontal deep drilling operations from 40xD, move the deep hole drill into the hole counter-clockwise at 200 1/min. This prevents sagging of the deep hole drill.



It is essential to ensure that deep hole drills never run unsupported at full speed in the machine !

WTX – Micro – recommended application

General references

- ▲ During vertical machining, a pilot hole is not required for regular and straight surfaces from Ø 1.0 mm up to a length of 12xD due to the excellent self-centring. During horizontal drilling, a pilot drill must be used for irregular and angled surfaces.
The WTX Micro 5xD is recommended as a pilot drill.
- ▲ To guarantee problem-free insertion of the deep hole twist drill in the pilot hole, during horizontal machining 90° countersinking with suitable NC countersink is recommended.
- ▲ During vertical machining, drills from Ø 1.0 mm up to a length of 12xD can also be operated outside the pilot hole without a reduction in speed.
- ▲ For through holes, the feed per revolution must be reduced by 50% before exiting the hole.
- ▲ For long-chipping materials, pecking may be required every 3xD from a hole depth of 10xD. Peck drilling (retraction) should occur at the pilot hole depth.
- ▲ Due to the small thro' coolant Ø during micro drilling, effective filtration of the cooling medium is of the utmost importance.
Drill < Ø 2.0 mm Filter ≤ 0.010 mm
Drill < Ø 3.0 mm Filter ≤ 0.020 mm
- ▲ The longer the coolant is in the machine, suspended particles and particulate matter in the cooling medium prevent effective coolant flow. Regular replacement of the coolant is therefore recommended.
- ▲ A suitable clamping device with maximum radial run-out accuracy and balance quality is required for process-secure production.
Radial run-out accuracy ≤ 0.003 mm
Suitable for high-speed areas
- ▲ To guarantee a process-secure drilling process, a minimum pressure of 30 bar must be present.

1 Producing the pilot hole



- ▲ Pilot hole depth: min. 3xD
- ▲ It must be ensured that the prepared pilot hole is free from chips to avoid blocking of the micro deep hole twist drill cutting edges

2 Entering the pilot hole with a deep hole twist drill



- ▲ Speed 300 1/min (reverse rotation sometimes possible)
- ▲ Entry speed approx. 1.000 mm/min
- ▲ Switch on cooling
- ▲ Increase parameters 0.5–1.0 mm before reaching the bottom of the pilot hole

3 Deep hole drilling



- ▲ At hole depth without pecking

4 Retracting the drill



- ▲ Retract drill approx. 1xD
- ▲ Reduce speed to 300 1/min
- ▲ Exit speed approx. 1.000 mm/min
- ▲ Switch off emulsion before exiting the hole

Tolerances and angles

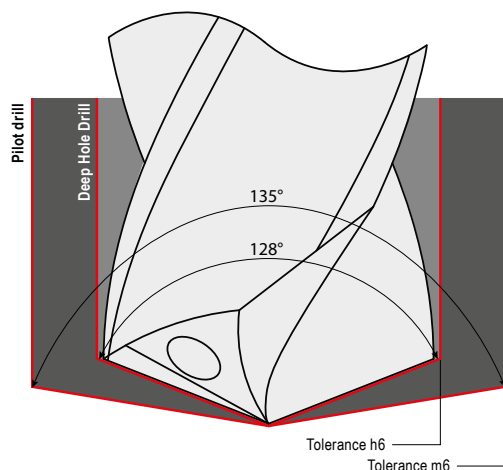

The following must apply to use the pilot and deep hole twist drill consecutively and without collisions:
 $\Delta D = \text{ØD (pilot hole)} - \text{ØD (deep hole)} > 0$

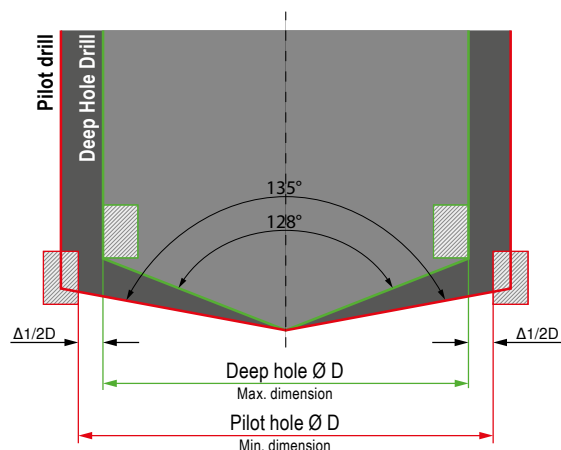

Application notes for WTX – Change Feed and WTX – Change exchangeable head drills

Coolant conditions

Coolant pressure dependent on drilling depth:

with thro' coolant	with external cooling	without coolant supply
1xD: 8 bar ✓	1xD: 8 bar ✓	max. bore depth: 3xD
3xD: 8 bar ✓	3xD: 8 bar ✓	
5xD: 12 bar ✓	5xD: 12 bar ✗	
8xD: 25 bar ✓	8xD: 25 bar ✗	
12xD: 25 bar ✓	12xD: 25 bar ✗	

Runout accuracy

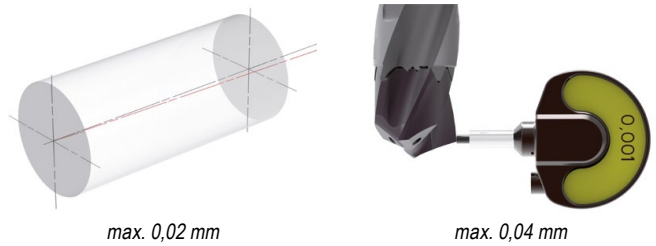

Max. entry and exit angle for the WTX – Change Feed

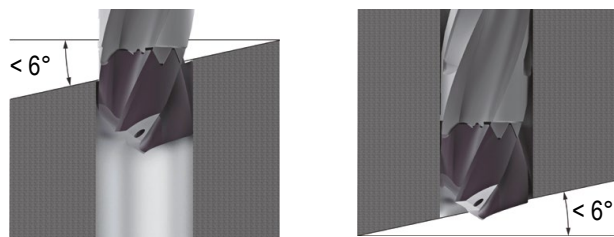

When entering and exiting angled surfaces, reduce v_f by 50 %.

Max. entry and exit angle for the WTX – Change

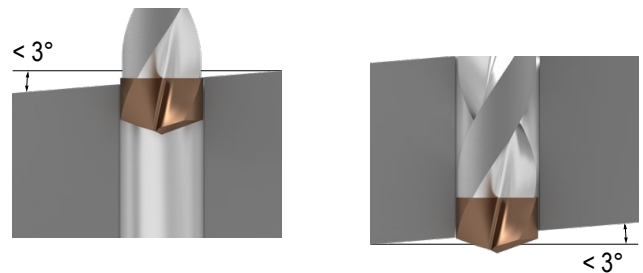

When entering and exiting angled surfaces, reduce v_f by 50 %.

Exiting a through hole

▲ WTX – Change Feed and WTX – Change

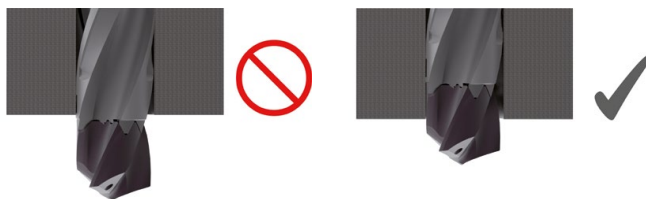

For through holes, it must be ensured that the exchangeable head does not fully protrude from the hole.

Do not retract at rapid feedrate

For withdrawal, a rate of 5 times the value of the feed rate is recommended.

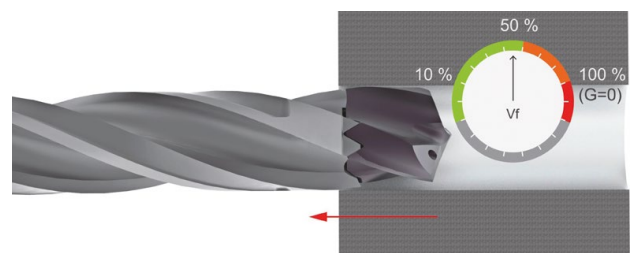

Machining situations

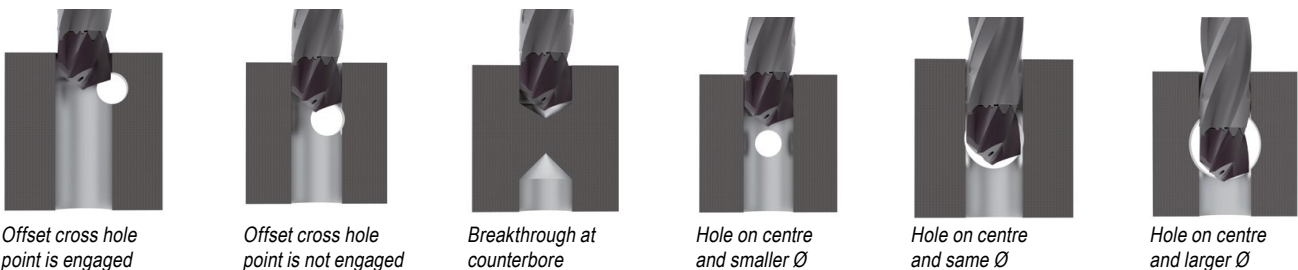

WTX – Change Feed ✓	WTX – Change Feed ✗	WTX – Change Feed ✓	WTX – Change Feed ✓	WTX – Change Feed ✗	WTX – Change Feed ✗
WTX – Change ✓	WTX – Change ✗	WTX – Change ✗	WTX – Change ✓	WTX – Change ✗	WTX – Change ✗

Application notes for WPC – Change indexable insert drill

Assembly of the indexable insert

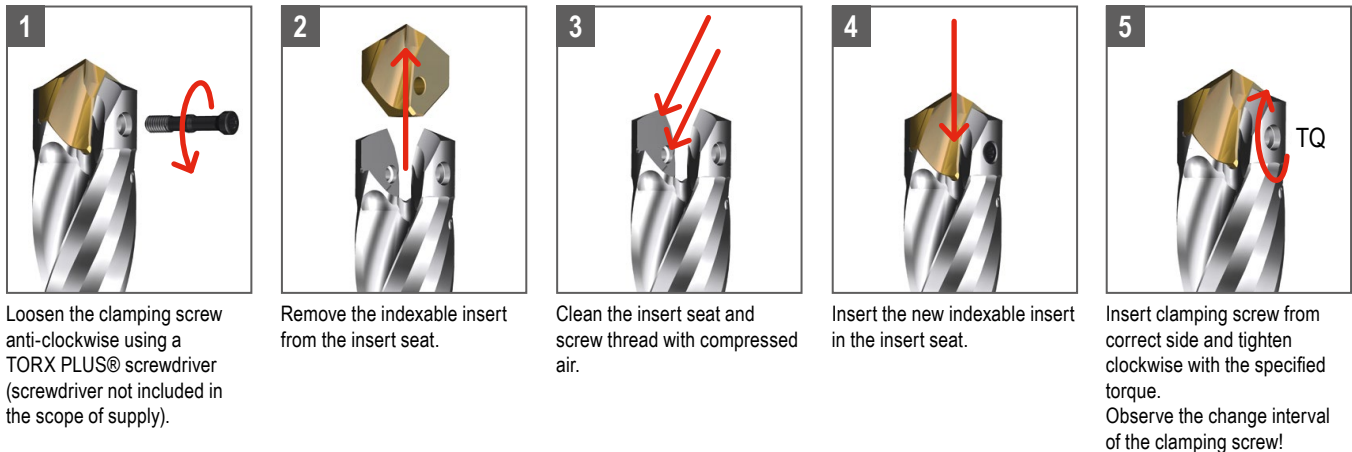

Notes

- ▲ Only insert indexable inserts in the diameter range designated for the respective holder.
- ▲ The clamping screw must also be replaced upon every fifth replacement of the indexable insert.
- ▲ The tightening torque and item number of the clamping screw are labelled on the holder.
- ▲ Use only original spare parts.

Clamping screws and tightening torques

Diameter range	Article no. Clamping screw	Drive	Torque moment TQ
14,00–15,99 mm	11 950 00100	08IP	0,9 Nm
16,00–17,99 mm	11 950 00200	08IP	1,2 Nm
18,00–21,99 mm	11 950 00300	10IP	2,2 Nm
22,00–23,99 mm	11 950 00400	10IP	3,2 Nm
24,00–25,99 mm	11 950 00500	15IP	5,0 Nm
26,00–30,00 mm	11 950 00600	20IP	6,0 Nm

Notes on drilling technology



Solid drilling



Stack plate drilling: stable clamping of closely spaced stack plates required.



When drilling into angled surfaces $< 3^\circ$, reduce the feed by approx. 50%.
For an angled drill entrance $> 3^\circ$, prior spot facing is required.



When exiting at an angle $< 3^\circ$, reduce the feed by approx. 50%.
Machining angled drill exits $> 3^\circ$ is not recommended.

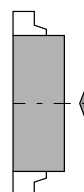

When machining with a stationary tool (turning machines), a precise centre position of the tool in relation to the rotational axis of the workpiece must be ensured. Maximum permissible offset ± 0.02 mm.



To achieve the optimal results, it is recommended to use the tool with thro' coolant only.
The recommended minimum coolant pressure should be 12 bar.

Recommendations for solid carbide drilling operations

Reasons for ...

Solutions ...

... Built-up edge

v_c too low
Too much material taken off at main cutting edge
Uncoated cutting edge



Increase v_c
Reduce cut
Coating

... Corners broken off

Unstable conditions
Run out too high
Interrupted cut



Change clamping
Optimise runout
Reduce feed

... Heavy flank wear

v_c too low
Feed rate too low
Clearance angle too small



Reduce v_c
Increase feed rate
Increase clearance angle

... Scoring on the tool flanks

Unstable conditions
Run out too high
Interrupted cut
Abrasive materials



Change clamping
Correct runout
Reduce feed
Thicker emulsion or oil

... Round chamfer wear

Unstable conditions
Run out too high
Back taper too small
Wrong emulsion or too thin emulsion



More stable clamping
Check radial run-out
Increase back taper
Thicker emulsion or oil

... Material broken off at main cutting edge

Unstable conditions
Interrupted cut
Wrong type of tool
Max. tool life has been exceeded



More stable clamping
Reduce feed
Optimise tool
Change tool earlier

... Heavy wear at chisel edge

v_c too low
Feed rate too high
Too much material taken off at main cutting edge



Increase v_c
Reduce feed
Optimise cutting edge

... Material broken off at intersections, drill point and main cutting edge

Clearance angle too small
Too much material taken off at main cutting edge
Wrong tool



Increase clearance angle
Optimize cutting edge
Other tool

... Plastic deformation of cutting corner

v_c too high
Insufficient emulsion
Wrong or no corner chamfer



Reduce v_c
Increase amount of coolant
Correct corner chamfer

... Poor surface quality

Excessive runout error
Cooling too low
Unstable conditions



Check radial run-out
More emulsion
Change toolholding

... Heavy burring on hole exit

Feed too high
Excessive honing of main cutting edge



Reduce feed
Minimise cutting edge

Further information

cutting.tools/en/en/tips-solid-carbide-drilling



Coatings

Ti800

- ▲ AlTiN nanolayer coating
- ▲ Maximum application temperature: 1100 °C

Ti700

- ▲ TiAlN multilayer coating
- ▲ Maximum application temperature: 1100 °C

TiAlN

- ▲ TiAlN multilayer coating
- ▲ Maximum application temperature: 900 °C

TiB

- ▲ TiB monolayer coating
- ▲ Specially for aluminium machining
- ▲ Maximum application temperature: 900 °C

TiSi

- ▲ TiSi multilayer coating
- ▲ Maximum application temperature: 800 °C

Ti1050

- ▲ Ti multilayer coating
- ▲ $HV_{0.005} = 3300$
- ▲ Coefficient of friction (against steel) = 0.3 – 0.5
- ▲ Maximum application temperature: 900 °C

Ti750

- ▲ TiAlN nanolayer coating
- ▲ Maximum application temperature: 1000 °C

TPX74S

- ▲ TiAlN-based PVD multilayer coating
- ▲ Universally applicable grade with high wear-resistance
- ▲ Maximum application temperature: 900 °C

DPX74S

- ▲ Special TiAlN nanolayer coating
- ▲ Maximum application temperature: 1000 °C

DRAGONSKIN

DPA54

- ▲ Special multilayer coating
- ▲ High hardness and heat resistance
- ▲ Maximum application temperature: 800 °C

DRAGONSKIN

DLC

- ▲ Diamond-like carbon coating
- ▲ Specially for machining non-ferrous metals
- ▲ Maximum application temperature: 400 °C

DRAGONSKIN

DPX14S

- ▲ TiAlN nanolayer coating
- ▲ Coefficient of friction (dry, against steel) = 0.35
- ▲ Maximum application temperature: 1000 °C

DRAGONSKIN

DPX64U

- ▲ Special TiAlN monolayer coating
- ▲ Perfected for hardened materials
- ▲ Optimised coating and surface structure
- ▲ Maximum application temperature: 800 °C

DRAGONSKIN

DPX74M

- ▲ Universal AlCrN-based monolayer coating developed for micro tools
- ▲ High oxidation, heat and wear resistance
- ▲ Maximum application temperature 1100 °C

DRAGONSKIN