



 ZSG 1

 CERATIZIT GROUP MNG mini

 ZSG mini

Novi izdelki za vpenjalno tehniko

NEW Mehanski vpenjalni sistem z ničelno točko – MNG mini



149-151

**MNG
mini**

Nosilci, piramide in vpenjalni stolpi z optimizirano težo z integriranim vpenjalnim sistemom z ničelno točko za majhne vpenjalne naprave.

NEW CentriClamp – ZSG mini



92-100

**ZSG
mini**

Centrični primež ZSG mini je prava izbira za vpenjanje manjših obdelovancev!

NEW PolyClamp – Verso



111-124

Verso

Nov, fleksibilen večkratni primež s sistemom za hitro menjavo čeljusti, primeren za številne manjše in večje obdelovance!

1 Svedri HSS

2 Svedri VHM

3 Svedri z obračalnimi ploščicami

4 Povrtala in grezila

5 Izstruževalna orodja

6 Navojni svedri in oblikovalci navojev

7 Kolutni in navojni rezkarji

8 Struženje navojev

9 Stružna orodja

10 Večnamenska orodja EcoCut in FreeTurn

11 Zarezovalna orodja

12 Miniaturna orodja za struženje

13 Rezkarji HSS

14 Rezkarji VHM

15 Rezkalne glave z obračalnimi ploščicami

16 Vpenjala za orodja in pribor

17 Vpenjanje obdelovancev

18 Primeri materialov in seznam št. artiklov

Obdelava izvirin

Obdelava navojev

Obdelava s struženjem

Obdelava z rezkanjem

Vpenjalne tehnike

Kazalo

PolyClamp – Verso	4
Pregled vpenjalnih sistemov	5
Toolfinder – Za vpenjalne sisteme	6–9
Program izdelkov	10–183
Pregled splošnih čeljustnih nastavkov	164–173
Pregled podlog za obdelovance	174–177
Pregled splošnega pribora	178+179
Pregled vpenjalnih ročic	180+181
Pregled vijakov	182+183

WNT \ Performance

Orodja premium kakovosti za največjo zmogljivost.

Orodja premium kakovosti iz linije izdelkov **WNT Performance** so bila zasnovana za posebna področja uporabe in jih odlikuje izjemna zmogljivost. Če imate pri proizvodnji visoke zahteve glede zmogljivosti in želite doseči kar najboljše rezultate, vam priporočamo premium izdelke iz te linije.

PolyClamp – Verso

Nastavljiva čeljust

- ▲ Samo ena velikost vijakov v celotnem sistemu
- ▲ Hitra in preprosta uporaba s pomočjo nameščanja čeljusti od zgoraj

Ozobljenje kaljeno in brušeno

- ▲ Visoka natančnost in trdnost strukture
- ▲ Zaščita pred poškodbami in obrabo

Vpenjalne čeljusti

- ▲ Hitra menjava s privijanjem in odvijanjem
- ▲ Čeljust z vlekom navzdol 40 mm
- ▲ Vzporedne vpenjalne čeljusti 40 / 65 / 90 mm
- ▲ Nihajoča prijemalna čeljust 90 mm

Nepomična čeljust

- ▲ Obrnljivo za 180°
- ▲ Prijemalna stopnica na obeh straneh
- ▲ Preprosto premikanje z indeksirnim ozobljenjem

Vpenjanje

- ▲ Prehodne izvrtine za rastrsko ploščo
- ▲ Komplet za izravnavo v T-utorih
- ▲ Vpenjalne izvrtine za vpenjalne čepe MNG

Lasersko gravirano merilo

- ▲ Za hitro namestitev vpenjalnih čeljusti

Izjemno toga vpenjalna tirnica

- ▲ Širina 90 mm
- ▲ Dolžine od 260 mm do 650 mm

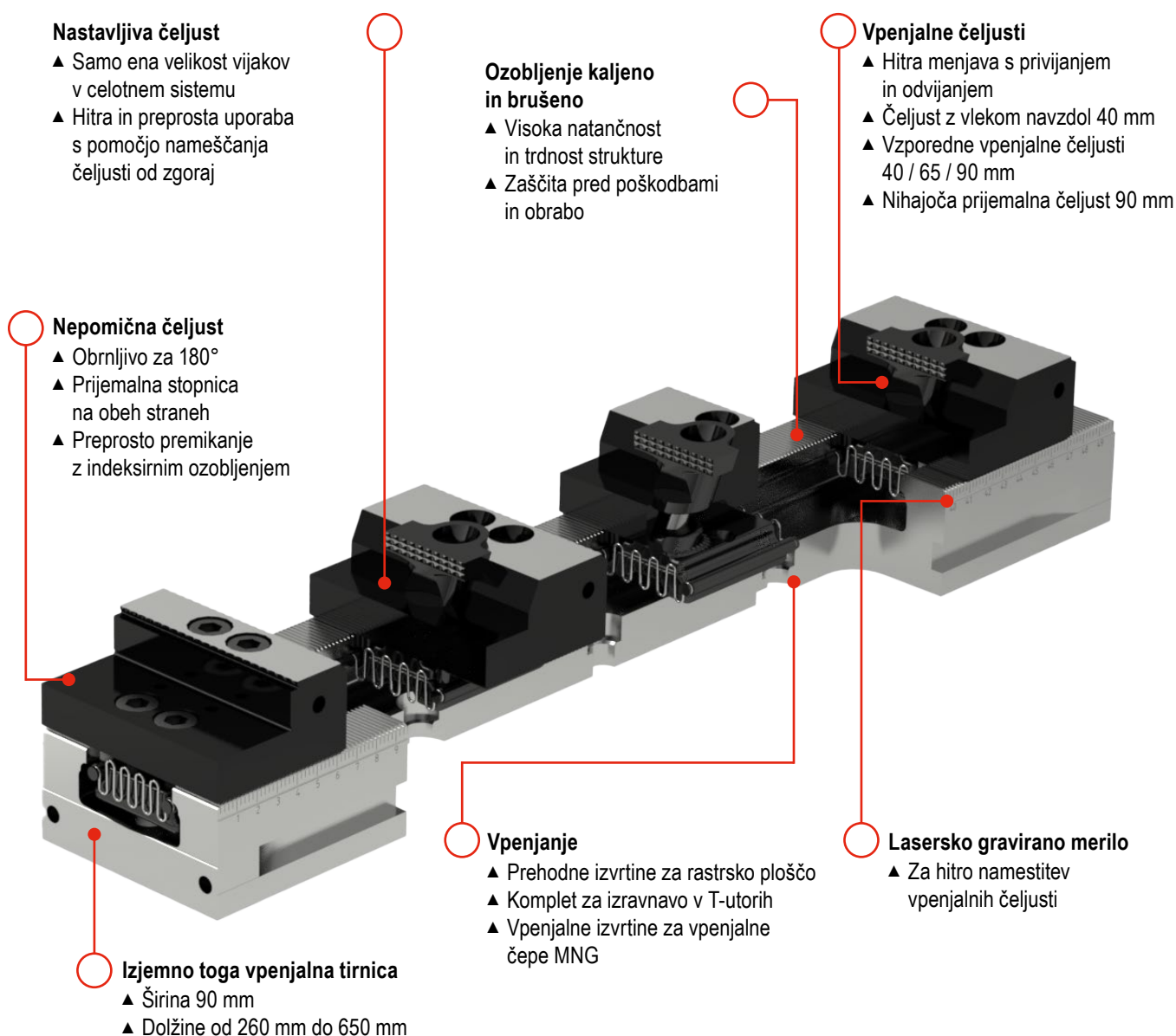

Pregled vpenjalnih sistemov

SoloClamp – Enojni vpenjalni primeži

- ▲ Podprto z ojačevalnikom sile v NCG, HDG 2 in H5G
- ▲ Nepomična čeljust je kot referenca
- ▲ Visoka natančnost ponovitve
- ▲ Zelo natančna kotnost



» Visoka preciznost in ojačevanje sile

CentriClamp – Centrični primeži

- ▲ Simetrično vpenjanje
- ▲ Zelo dobra dostopnost za obdelavo s petih strani
- ▲ Ničelna točka sestavnega dela je vedno na sredini (centrirana)
- ▲ Visoka natančnost ponovitve



» Visoka zaščita pri postopku z oklopljenim sistemom

PolyClamp – Večkratni primeži

- ▲ Krajši čas za pripravo
- ▲ Večnamenska uporaba
- ▲ Optimalna izraba strojne mize
- ▲ Visoka natančnost ponovitve



» Daljša življenjska doba stroja

Stacionarna tričeljustna vpenjalna glava – SBF 3

- ▲ primerno za 3/5-osno obdelavo okroglih komponent
- ▲ združljivo z vpenjalnimi sistemi z ničelno točko PNG in MNG
- ▲ Pogon s klinasto letvijo
- ▲ kaljeno in togo osnovno telo
- ▲ optimiziran sistem mazanja



Ø 200 mm

Ø 315 mm

» Popoln način vpenjanja okroglih komponent

Različice vpenjal

- ▲ Vpenjalni sistemi z ničelno točko
- ▲ Rastrske plošče za vpenjalni sistem z ničelno točko
- ▲ MNG – mehanski vpenjalni sistem z ničelno točko
- ▲ PNG – pnevmatski vpenjalni sistem z ničelno točko



» Krajši čas za pripravo

Vpenjalni stolpi

- ▲ Vpenjalni stolp z dvema stranema
- ▲ Trikotni vpenjalni stolp
- ▲ Križni vpenjalni stolp
- ▲ Kockasti vpenjalni stolp



» Enostavna avtomatizacija



Različne vpenjalne stolpe najdete v naši spletni trgovini na naslovu cuttingtools.ceratzit.com







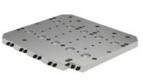

Toolfinder za vpenjalne sisteme

Tip	Opis	3-osna različica	4-osna različica	5-osna različica	
SoloClamp – Enojni vpenjalni primeži	NCG 	<ul style="list-style-type: none"> ▲ 160-stopinjsko hitro vpenjanje ▲ Hitrejša namestitvev in odstranjevanje sestavnih delov vretena ▲ Vpenjanje na vlek 	✓	✓	
	NCG 5A 	<ul style="list-style-type: none"> ▲ 160-stopinjsko hitro vpenjanje ▲ Za 5-osno obdelavo ▲ Vpenjanje na vlek 	✓		✓
	H5G 	<ul style="list-style-type: none"> ▲ Hitro vpenjanje z ročico ▲ 5-osni kompaktni primež ▲ 100 odstotno oklopljen 	✓		✓
	H5G -Z 	<ul style="list-style-type: none"> ▲ Hitro vpenjanje z ročico ▲ 5-osni kompaktni primež ▲ 100 odstotno oklopljen ▲ z mobilno nepomično čeljustjo 	✓		✓
	X5G -Z 	<ul style="list-style-type: none"> ▲ 100 odstotno oklopljen ▲ Najboljša dostopnost ▲ Možni sta 5- in 6-stranska obdelava ▲ Hitra menjava čeljusti brez orodja 	✓		✓
	ESG 4 	<ul style="list-style-type: none"> ▲ 100 odstotno oklopljen ▲ Natančno osnovno telo ▲ Visoka vpenjalna sila ▲ Veliko območje vpenjanja 	✓	✓	✓
	ESG 5 	<ul style="list-style-type: none"> ▲ Nova izvedba oklopljenega centričnega primeža ZSG 4 kot enojnega primeža ▲ Enake mere in delovanje kot pri ZSG 4 	✓	✓	✓
	HDG 2 	<ul style="list-style-type: none"> ▲ Mehanski prenos moči ▲ Vpenjalna sila s samo enim vrtljajem pogonske ročice ▲ Brezstopenjska nastavitve vpenjalne sile 	✓		
CentriClamp – Centrični primeži	ZSG 4 	<ul style="list-style-type: none"> ▲ S krogličnimi ležaji, vreteno brez zračnosti ▲ Visoka preciznost, vpenjalna sila in zaščita pri postopku ▲ Natančnost ponovitve $\pm 0,01$ mm 	✓	✓	✓
	ZSG mini 	<ul style="list-style-type: none"> ▲ Hitra menjava čeljusti brez orodja ▲ Kompaktnost in preciznost ▲ Najboljša dostopnost z vseh strani ▲ Nerjavno in kaljeno osnovno telo 	✓	✓	✓

	Širina čeljusti v mm	Dolžina osnovnega telesa v mm	Najv. območje vpenjanja v mm	Kubični obdelovanci	Obdelovanci brez določene oblike	Okrogli obdelovanci	Najv. vpenjalna sila v kN	Stran
	100 125 160	305 390 530	245 343 506	✓	✓	✓	30 40 40	10-21
	100 125	305 390	199 269	✓		✓	18 24	13-21
	125	300	249	✓	✓	✓	40	22-36
	125	330 430 500 630	396 466 578	✓	✓	✓	40	26-36
	125	330 430 500 630 800	80-210 80-310 80-380 80-510 80-688	✓	✓	✓	40	37
	80 125 160	214 362 480	192 308 434	✓	✓	✓	25 40 50	49-58
	80 125 160	130+190 160+235+300 280+480	63-171 84-281 125-448	✓	✓	✓	35 35 50	59-66
	100 125 160	342 400 544	278 338 470	✓		✓	30 40 60	68-71
	80 125 160	130+190 160+235+300 280+480	121-185 163-303 134-462	✓	✓	✓	25 40 50	72-90
	45 70	80 100	7-77	✓	✓	✓	16	92-100



Toolfinder za vpenjalne sisteme

Tip	Opis	3-osna različica	4-osna različica	5-osna različica
PolyClamp – Večkratni primeži	DSG 4  <ul style="list-style-type: none"> ▲ Hitra namestitvev in odstranitvev ▲ prilagodljiv vpenjalni sistem ▲ Možna pretvorba v enojni primež 	✓	✓	✓
	Verso  <ul style="list-style-type: none"> ▲ variabilen vpenjalni sistem ▲ možnost vpenjanja več manjših in večjih komponent ▲ inovativni sistem večkratnega vpenjanja 	✓	✓	✓
Stacionarna tričeljustna vpenjalna glava	SBF 3  <ul style="list-style-type: none"> ▲ primerno za 3/5-osno obdelavo okroglih komponent ▲ združljivo z vpenjalnimi sistemi z ničelno točko PNG in MNG 	✓		✓
	 <ul style="list-style-type: none"> ▲ primerno za 3/5-osno obdelavo okroglih komponent ▲ združljivo z vpenjalnimi sistemi z ničelno točko PNG in MNG 	✓		✓

Tip	Opis
Vpenjalni sistemi z ničelno točko Mehansko Pnevmatsko	MNG    <ul style="list-style-type: none"> ▲ Večnamenska plošča za vsako strojno mizo
	MNG mini    <ul style="list-style-type: none"> ▲ Za vpetje obdelovancev majhnih dimenzij
	PNG   <ul style="list-style-type: none"> ▲ Zaščita pri postopku zaradi samozapornosti
Vpenjalni stolpi	 <ul style="list-style-type: none"> ▲ Daljša življenjska doba stroja

Ročni primeži za vrtalne stroje

Primež za vrtalne stroje	HSG  <ul style="list-style-type: none"> ▲ Hitra nastavitvev čeljusti, kompaktno in precizno
--------------------------	---

Širina čeljusti v mm	Dolžina osnovnega telesa v mm	Najv. območje vpenjanja v mm	Kubični obdelovanci	Obdelovanci brez določene oblike	Okrogli obdelovanci	Najv. vpenjalna sila v kN	Stran
80	300	102		✓	✓	25	101-110
125	320+390+460 530+600+670+740	114+149+184 219+254+289+324		✓	✓	40	
40 65 90	260 -650	524	✓	✓	✓	30	111-124
	Ø 200	Čeljusti SB-H 6-180			✓	100	125-130
	Ø 315	Čeljusti SB-H 12-420			✓	180	
	Mehansko	Pnevmatsko			Pripomba		Stran
	✓						134-148
	✓						149-151
		✓					152-163
	✓				Te artikle najdete v naši spletni trgovini na naslovu cuttingtools.ceratizit.com	 	
	✓						131-133

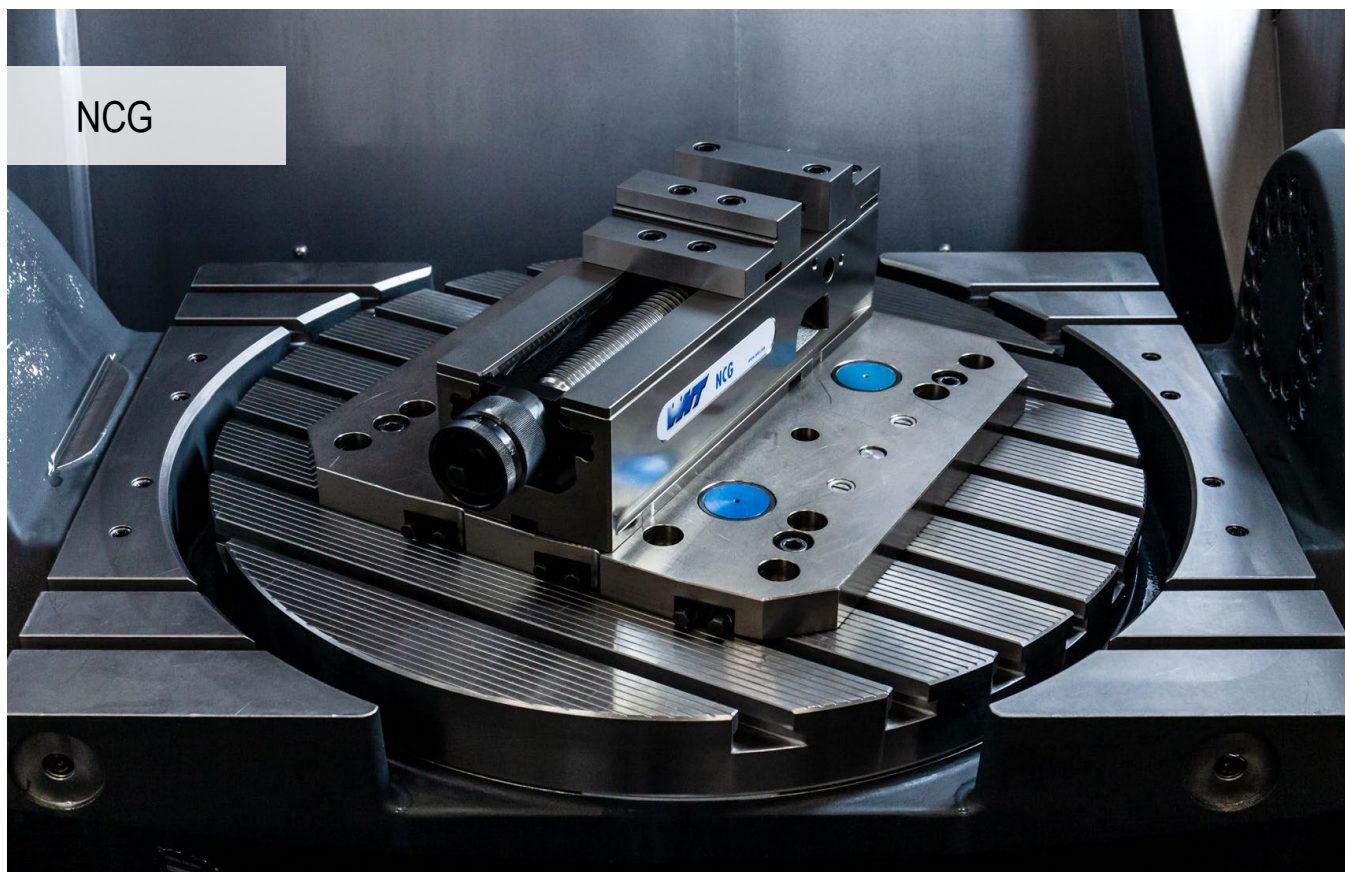

NCG

vpenjanje s sistemom

Strojni primež z modularno zgradbo kot sistem z vpenjanjem na vlek.
Edinstveno, patentirano hitro vpenjanje z ročico z mehanskim ojačanjem sile in zelo hitro namestitvijo.

Prednosti za vas:

- ▲ Hitra nastavitve s pomočjo pogonske ročice
- ▲ Hitro pozicioniranje z MNG na strojni mizi brez vmesne palete
- ▲ Brezstopenjsko nastavljiva vpenjalna sila od 4 do 40 kN
- ▲ 160-stopinjsko hitro vpenjanje
- ▲ Preprosta in hitra menjava čeljusti s 4 vijaki
- ▲ Preprosto čiščenje zaradi hitre odstranitve celotne vretenske enote
- ▲ Obsežen program modularnih čeljusti



Vpenjanje/usmerjanje:



Vpenjanje z dvema vijakoma za namestitev v velikosti
 $\varnothing 12_{17}$ / M12 (NCG 100) **Kataloška št. 80 890 313**
ali $\varnothing 16_{95}$ / M16 (NCG 125 / 160)
Kataloška št. 80 890 314



Usmerjanje z natančnimi utornimi maticami 20^{H7}
v osnovnem telesu in vpenjanje z vpenjalnimi
sponami



Usmerjanje in vpenjanje z vpenjalnim sistemom
z ničelno točko MNG (2-3 vpenjalni čepi)

SoloClamp – NCG

- ▲ Hitro vpenjalni primež NC s kombinirano obrnljivo čeljustjo Plus
- ▲ Zaradi dodatnega navoja je mogoče uporabiti čeljustne nastavke višine 18 mm in 40 mm

Obseg dobave:

Hitri primež NC, vključno s 4 vpenjalnimi sponami, 2 kombinirani obrnljivi čeljusti Plus, vpenjalna ročica

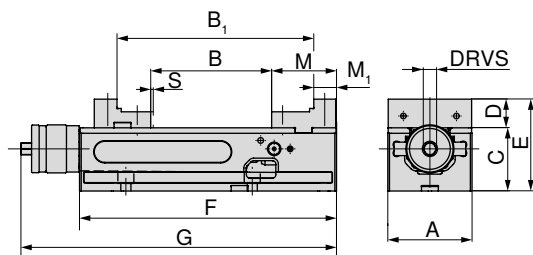
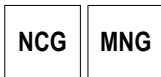

A	B	B ₁	C _{-0.02}	D	E	F	G	M	M ₁	S	DRVS	MXC	WT
mm	mm	mm	mm	mm	mm	mm	mm	mm	mm	mm	mm	kN	kg
125	0 - 212	96 - 307	100	39	139	390	457	89	39	3	14	4 - 40	34

80 890 ...

EUR
Y4

3.110,00 12500

SoloClamp – NCG

- ▲ Hitro vpenjalni primež NC z 2 kombiniranimi obrnljivima čeljustma
- ▲ Hitro 160-stopinjno vpenjanje z ročico
- ▲ Hitrejša namestitvev in odstranjevanje sestavnih delov vretena
- ▲ S = vpenjalni hod

Obseg dobave:

Hitri primež NC, vključno s 4 vpenjalnimi sponami, 2 kombinirani obrnljivi čeljusti (ena stran stopenjska, ena stran gladka), vpenjalna ročica

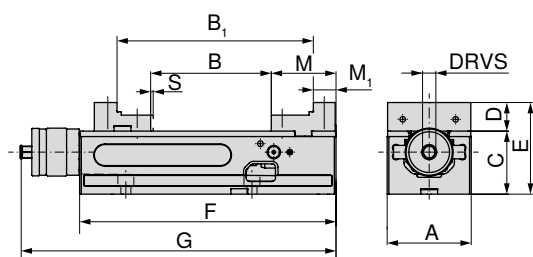
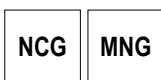

A	B	B ₁	C _{-0.02}	D	E	F	G	M	M ₁	S	DRVS	MXC	WT
mm	mm	mm	mm	mm	mm	mm	mm	mm	mm	mm	mm	kN	kg
100	0 - 155	91 - 245	75	34	109	305	374	77	27	2,5	14	4 - 30	19
125	0 - 212	96 - 307	100	39	139	390	457	89	39	3	14	4 - 40	34
160	0 - 314	113 - 426	115	49	164	530	600	108	52	3	14	4 - 40	68

80 890 ...

EUR
Y4

2.660,00 602

3.080,00 627

4.040,00 662

Vodnik po primežih

Mere spodnje strani	14	Pribor za sisteme	16-21
Vpenjalni sistem z ničelno točko MNG/PNG	134-163	Splošni pribor	164-183

SoloClamp – NCG

- ▲ Hitri vpenjalni primež NC z obrnljivo čeljustjo v standardni izvedbi
- ▲ Hitro 160-stopinjsko vpenjanje z ročico
- ▲ Hitrejša namestitvev in odstranjevanje sestavnih delov vretena
- ▲ S = vpenjalni hod

Obseg dobave:

Hitri primež NC, vklj. s 4 vpenjalnimi sponami, 2 obrnljivi čeljusti v standardni izvedbi (ena stran gladka, ena stran rebrasta), vpenjalna ročica

NCG

MNG

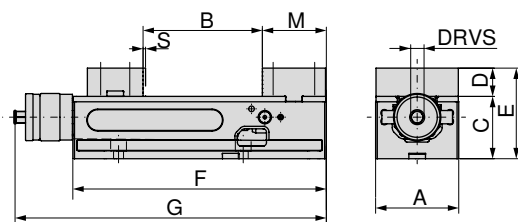

A	B	C _{-0.02}	D	E	F	G	M	S	DRVS	MXC	WT
mm	mm	mm	mm	mm	mm	mm	mm	mm	mm	kN	kg
100	0 - 155	75	34	109	305	374	77	2,5	14	4 - 30	19,5
125	0 - 212	100	39	139	390	457	89	3	14	4 - 40	35,0
160	0 - 314	115	49	164	530	600	108	3	14	4 - 40	70,0

80 890 ...

EUR

Y4

2.580,00 600

3.010,00 625

3.960,00 660

SoloClamp – NCG

- ▲ Hitri vpenjalni primež NC z adaptersko in nihajočo čeljustjo
- ▲ Hitro 160-stopinjsko vpenjanje z ročico
- ▲ Hitrejša namestitvev in odstranjevanje sestavnih delov vretena
- ▲ S = vpenjalni hod
- ▲ Preprosto vpenjanje surovca
- ▲ Prosto nameščanje 6-kratne obrnljive čeljusti iz pribora

Obseg dobave:

Hitri primež NC (osnovno telo tipa NCG) z 1 fiksno adaptersko čeljustjo in 1 nihajočo čeljustjo, vpenjalna ročica, 4 vpenjalne spono, brez 6-kratnih obrnljivih čeljustnih nastavkov

NCG

MNG

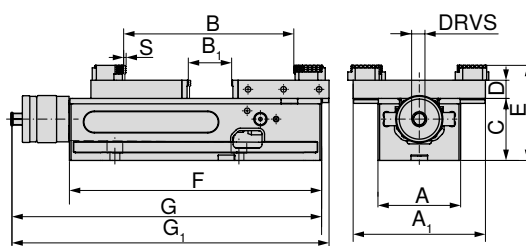

A	A ₁	B	B ₁	C _{-0.02}	D	E	F	G	G ₁	S	DRVS	MXC	WT
mm	mm	mm	mm	mm	mm	mm	mm	mm	mm	mm	mm	kN	kg
100	160	10 - 230	0 - 77	75	22	115	305	374	383	2,5	14	4 - 30	19
125	192	16 - 343	0 - 152	100	22	140	390	457	478	3	14	4 - 40	34
160	256	15 - 506	0 - 237	115	22	155	530	600	631	3	14	4 - 40	68

80 890 ...

EUR

Y4

2.770,00 636

3.220,00 637

4.250,00 638

Vodnik po primežih

Mere spodnje strani

14

Pribor za sisteme

16-21

Vpenjalni sistem z ničelno točko MNG/PNG

134-163

Splošni pribor

164-183

SoloClamp – NCG 5A

- ▲ Hitri vpenjalni primež NC 5A z visoko nosilno čeljustjo
- ▲ Hitro 160-stopinjno vpenjanje z ročico
- ▲ Hitrejša namestitvev in odstranjevanje sestavnih delov vretena
- ▲ S = vpenjalni hod
- ▲ Zaradi optimalnega dostopa idealno za obdelavo s petih strani
- ▲ Čeljusti se lahko obračajo za povečanje območja vpenjanja
- ▲ Osnovno telo 100 mm ima 2 utora za namestitvev nepomične čeljusti
- ▲ Osnovno telo 125 mm ima 3 utore za namestitvev nepomične čeljusti

Obseg dobave:

Hitri primež NC, vklj. z 2 visokima nosilnima čeljustma, 2 prijemalnima stopničastima čeljustma 5 mm, 1 vpenjalno ročico, 4 vpenjalnimi sponami

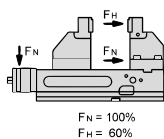
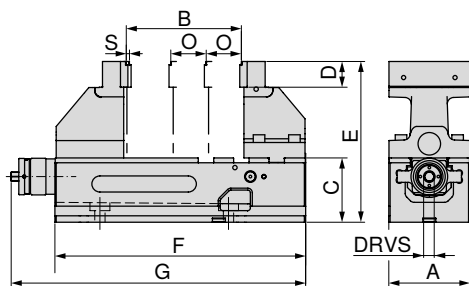
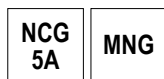

A	B	C	D	E	F	G	O	S	DRVS	MXC	WT
mm	mm	mm	mm	mm	mm	mm	mm	mm	mm	kN	kg
100	6 - 127	75	35	200	305	374	50	2,5	14	4 - 18 (30)	21,5
125	6 - 179	100	40	250	390	457	55	3	14	4 - 24 (40)	42,0

80 890 ...

EUR
Y43.210,00 605
3.710,00 635

Vodnik po primežih

Mere spodnje strani	14	Preglednice z merami za različne čeljusti	15
Pribor za sisteme	16–21	Vpenjalni sistem z ničelno točko MNG/PNG	134–163
Splošni pribor	164–183		

Mere spodnje strani NCG

Širina osnovnega telesa 100 mm

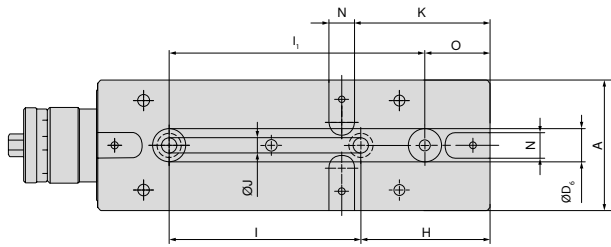

A	H	I _{±0,015}	J _{F7}	K	N _{H7}	O	I _{1±0,015}	D _{6 H7}
mm	mm	mm	mm	mm	mm	mm	mm	mm
100	100	150	12	105	20	50	200	25

Širina osnovnega telesa 125 mm

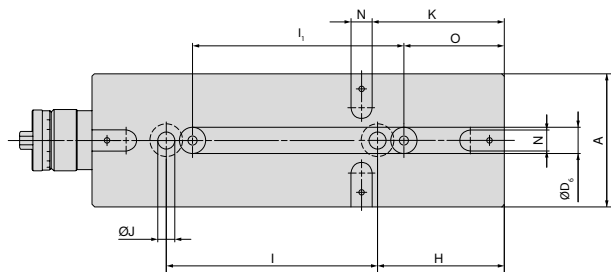

A	H	I _{±0,015}	J _{F7}	K	N _{H7}	O	I _{1±0,015}	D _{6 H7}
mm	mm	mm	mm	mm	mm	mm	mm	mm
125	120	200	16	125	20	95	200	25

Širina osnovnega telesa 160 mm

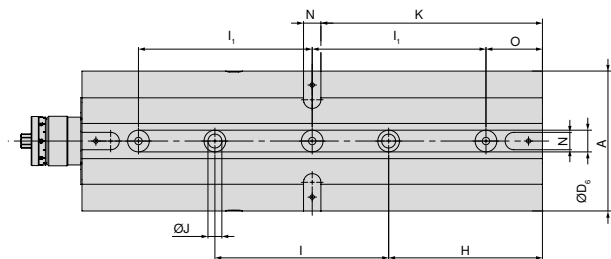

A	H	I _{±0,015}	J _{F7}	K	N _{H7}	O	I _{1±0,015}	D _{6 H7}
mm	mm	mm	mm	mm	mm	mm	mm	mm
160	177	200	16	255	20	65	200	25

Preglednica z merami NCG 5A za različne položaje čeljusti

NCG 5A 100 mm

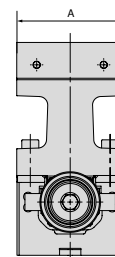
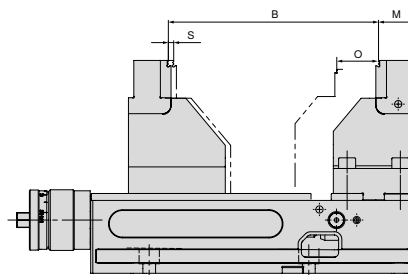
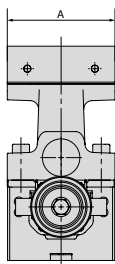
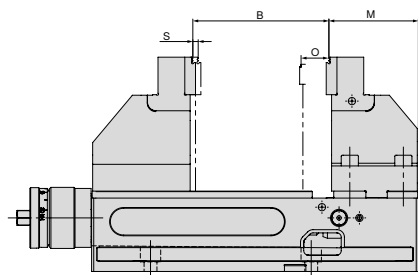

A mm	B mm	M mm	O mm	S mm
100	6 - 127	84,5	50	2,5

A mm	B mm	M mm	O mm	S mm
100	97 - 199	34,5	50	2,5

NCG 5A 125 mm

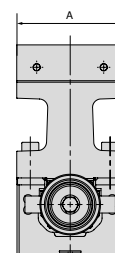
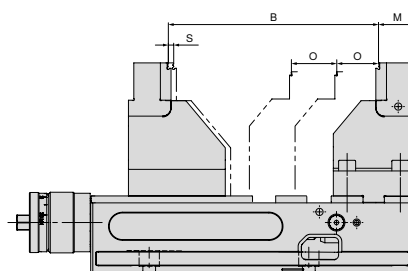
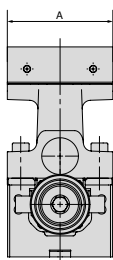
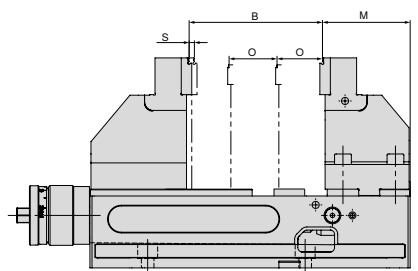

A mm	B mm	M mm	O mm	S mm
125	6 - 182	91	55	3

A mm	B mm	M mm	O mm	S mm
125	117 - 269	36	55	3

Pregled sistemov čeljusti

Kombinirana obrnljiva čeljust Plus, fiksna

- ▲ Za povečanje območja vpenjanja
- ▲ Čeljusti, kaljene
- ▲ Vklj. s pritrdilnimi vijaki
- ▲ Cena za kos

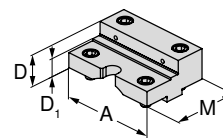

Za širino primeža	A	A ₁	D	D ₁	D ₂	E	M	M ₁	M ₂
125	125		39,8	22			88		

EUR

Y4

377,00

80 890 35100

NCG	H5G / -S / -Z	X5G-Z / -S	ESG 4	ESG 5	HDG 2	ZSG 4	ZSG mini	DSG 4	Verso	HSG
•										

Kombinirana obrnljiva čeljust Plus, pomična

- ▲ Za povečanje območja vpenjanja
- ▲ Čeljusti, kaljene
- ▲ Vklj. s pritrdilnimi vijaki
- ▲ Cena za kos

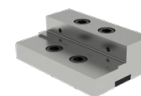
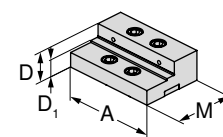

Za širino primeža	A	A ₁	D	D ₁	D ₂	E	M	M ₁	M ₂
125	125		39,8	22			82		

EUR

Y4

377,00

80 890 35200

NCG	H5G / -S / -Z	X5G-Z / -S	ESG 4	ESG 5	HDG 2	ZSG 4	ZSG mini	DSG 4	Verso	HSG
•										

Obrnljiva čeljust v standardni izvedbi, fiksna

- ▲ 1 stran gladka, 1 stran rebrasta
- ▲ Vklj. s pritrdilnimi vijaki
- ▲ Cena za kos

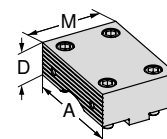

Za širino primeža	A	A ₁	D	D ₁	D ₂	E	M	M ₁	M ₂
100	100		34				76		
125	125		39				88		
160	160		49				108		

EUR

Y4

247,00

80 890 323

323,00

80 890 324

407,00

80 890 325

NCG	H5G / -S / -Z	X5G-Z / -S	ESG 4	ESG 5	HDG 2	ZSG 4	ZSG mini	DSG 4	Verso	HSG
•										
•										
•										

Obrnljiva čeljust v standardni izvedbi, pomična

- ▲ 1 stran gladka, 1 stran rebrasta
- ▲ Vklj. s pritrdilnimi vijaki
- ▲ Cena za kos

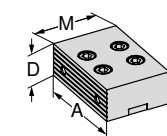

Za širino primeža	A	A ₁	D	D ₁	D ₂	E	M	M ₁	M ₂
100	100		34				67		
125	125		39				82		
160	160		49				108		

EUR

Y4

247,00

80 890 327

323,00

80 890 328

407,00

80 890 329

NCG	H5G / -S / -Z	X5G-Z / -S	ESG 4	ESG 5	HDG 2	ZSG 4	ZSG mini	DSG 4	Verso	HSG
•										
•										
•										

Pregled sistemov čeljusti

Kombinirana obrnljiva čeljust, fiksna

- ▲ Za povečanje območja vpenjanja
- ▲ Čeljusti, kaljene
- ▲ Vklj. s pritrdilnimi vijaki
- ▲ Cena za kos

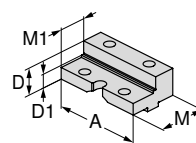

Za širino primeža	A	A ₁	D	D ₁	D ₂	E	M	M ₁	M ₂	EUR	Y4	NCG	H5G / -S / -Z	X5G-Z / -S	ESG 4	ESG 5	HDC 2	ZSG 4	ZSG mini	DSG 4	Verso	HSG		
100	100		34	23			76	50		285,00	80 890 343	●												
125	125		39	25			88	50		363,00	80 890 344	●												
160	160		49	28			108	56		446,00	80 890 342	●												

Kombinirana obrnljiva čeljust, pomična

- ▲ Za povečanje območja vpenjanja
- ▲ Čeljusti, kaljene
- ▲ Vklj. s pritrdilnimi vijaki
- ▲ Cena za kos

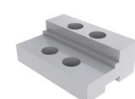
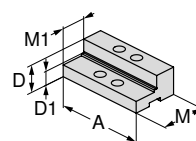

Za širino primeža	A	A ₁	D	D ₁	D ₂	E	M	M ₁	M ₂	EUR	Y4	NCG	H5G / -S / -Z	X5G-Z / -S	ESG 4	ESG 5	HDC 2	ZSG 4	ZSG mini	DSG 4	Verso	HSG			
100	100		34	23			67	40		285,00	80 890 347	●													
125	125		39	25			82	45		363,00	80 890 348	●													
160	160		49	28			108	56		446,00	80 890 346	●													

Mehka čeljust, jeklo, fiksna

- ▲ Material: 16MnCr5
- ▲ Za izdelavo oblikovnih čeljusti (toplotno obdelane)
- ▲ brez pritrdilnih vijakov
- ▲ Cena za kos

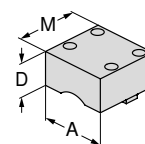

Za širino primeža	A	A ₁	D	D ₁	D ₂	E	M	M ₁	M ₂	EUR	Y4	NCG	H5G / -S / -Z	X5G-Z / -S	ESG 4	ESG 5	HDC 2	ZSG 4	ZSG mini	DSG 4	Verso	HSG			
100	100		50				95			143,40	80 890 763	●													
125	125		50				110			149,70	80 890 764	●													

Čeljust v mehki izvedbi, jeklo, pomična

- ▲ Material: 16MnCr5
- ▲ Za izdelavo oblikovnih čeljusti (toplotno obdelane)
- ▲ brez pritrdilnih vijakov
- ▲ Cena za kos

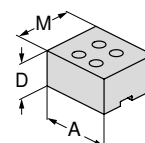

Za širino primeža	A	A ₁	D	D ₁	D ₂	E	M	M ₁	M ₂	EUR	Y4	NCG	H5G / -S / -Z	X5G-Z / -S	ESG 4	ESG 5	HDC 2	ZSG 4	ZSG mini	DSG 4	Verso	HSG			
100	100		50				85			143,90	80 890 767	●													
125	125		50				100			151,10	80 890 768	●													

Pregled sistemov čeljusti

5-osna nosilna čeljust, fiksna

- ▲ Cena za kos
- ▲ S stopničasto čeljustjo, prijemalna, 5 mm

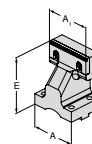

Za širino primeža	A	A ₁	D	D ₁	D ₂	E	M	M ₁	M ₂	EUR	Y4	NCG	H5G / -S / -Z	X5G-Z / -S	ESG 4	ESG 5	HDG 2	HDG 4	ZSG 4	ZSG mini	DSG 4	Verso	HSG	
100	100	100				125				554,00	80 890 364	●												
125	125	125				150				666,00	80 890 366	●												

5-osna nosilna čeljust, pomična

- ▲ Cena za kos
- ▲ S stopničasto čeljustjo, prijemalna, 5 mm

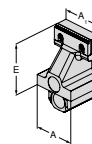

Za širino primeža	A	A ₁	D	D ₁	D ₂	E	M	M ₁	M ₂	EUR	Y4	NCG	H5G / -S / -Z	X5G-Z / -S	ESG 4	ESG 5	HDG 2	HDG 4	ZSG 4	ZSG mini	DSG 4	Verso	HSG	
100	100	100				125				589,00	80 890 365	●												
125	125	125				150				730,00	80 890 367	●												

Adapterska čeljust, nepomična

- ▲ Za vpenjanje 6-delnih obrnljivih čeljustnih nastavkov
- ▲ Cena za kos
- ▲ Vklj. s 6 pokrivnimi vijaki

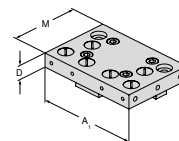

Za širino primeža	A	A ₁	D	D ₁	D ₂	E	M	M ₁	M ₂	EUR	Y4	NCG	H5G / -S / -Z	X5G-Z / -S	ESG 4	ESG 5	HDG 2	HDG 4	ZSG 4	ZSG mini	DSG 4	Verso	HSG	
100	100	160	22				110			278,00	80 890 321	●												
125	125	192	22				130			397,00	80 890 337	●												
160	160	256	22				170			521,00	80 890 339	●												

Vrtljiva čeljust, pomična

- ▲ Za vpenjanje 6-delnih obrnljivih čeljustnih nastavkov
- ▲ Cena za kos
- ▲ Vklj. s 6 pokrivnimi vijaki (pri A = 100 mm, 4 kosi)

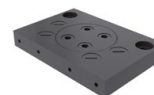
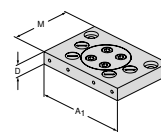

Za širino primeža	A	A ₁	D	D ₁	D ₂	E	M	M ₁	M ₂	EUR	Y4	NCG	H5G / -S / -Z	X5G-Z / -S	ESG 4	ESG 5	HDG 2	HDG 4	ZSG 4	ZSG mini	DSG 4	Verso	HSG	
100	100	160	22				110			401,00	80 890 322	●												
125	125	192	22				130			472,00	80 890 338	●												
160	160	256	22				170			582,00	80 890 340	●												

Pregled sistemov čeljusti

6-delni čeljustni nastavek

- ▲ 1 = Gladka, prevlečena z volframovim karbidom
- ▲ 2 = Prijemalo s stopnico 3 mm
- ▲ 3 = Prijemalo s stopnico 8 mm
- ▲ 4 = Prijemalo s stopnico 18 mm
- ▲ 5 = Prijemalo, okroglo, s stopnico 8 mm
- ▲ 6 = Prijemalo, okroglo
- ▲ $M_{najv.} = 60 \text{ Nm}$
- ▲ Vklj. s pritrdilnimi vijaki

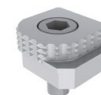
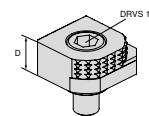

Za širino primeža	A	A ₁	D	D ₁	D ₂	E	M	M ₁	M ₂	EUR	Y4	NCG	H5G /-S /-Z	X5G-Z /-S	ESG 4	ESG 5	HGG 2	ZSG 4	ZSG mini	DSG 4	Verso	HSG	
			18							80,60	80 892 246	●	●	●	●				●		●	●	

6-delni čeljustni nastavek, s prijemalom iz karbidne trdine

- ▲ 1 = gladka
- ▲ 2 = karbidno prijemalo
- ▲ 3 = karbidno prijemalo s stopnico 3 mm
- ▲ 4 = karbidno prijemalo s stopnico 8 mm
- ▲ 5 = karbidno prijemalo, okroglo, s stopnico 8 mm
- ▲ 6 = karbidno prijemalo, okroglo
- ▲ vklj. s pritrdilnimi vijaki

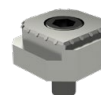
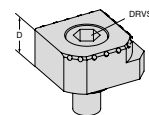

Za širino primeža	A	A ₁	D	D ₁	D ₂	E	M	M ₁	M ₂	EUR	Y4	NCG	H5G /-S /-Z	X5G-Z /-S	ESG 4	ESG 5	HGG 2	ZSG 4	ZSG mini	DSG 4	Verso	HSG	
			18							117,00	80 890 35300	●	●	●	●				●		●	●	

Pregled pribora za sisteme

Matica za vreteno

▲ Za predelavo tipa NCG 5AC v tip NCG

NCG NCG 5A



Za širino mm	80 890 ...
	EUR Y4
100	186,00 385
125	197,00 387
160	224,00 389

Ročaj za prenašanje

▲ Za preprost in varen transport

Obseg dobave:

1 kos ročaj, vklj. s pritrdilnimi vijaki

NCG NCG 5AC



Za širino mm	80 890 ...
	EUR Y4
100/125	18,20 685

Podaljšek potezne palice

▲ za povezavo 2 primežev NCG

NCG NCG 5A



Za širino mm	B mm	80 890 ...
		EUR Y4
100	305 - 460	318,00 460
125	390 - 602	349,00 470

Zaščitna plošča

▲ Za premično standardno čeljust, obrnljivo kombinirano čeljust in obrnljivo kombinirano čeljust plus

NCG

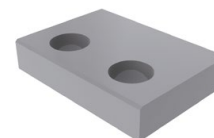
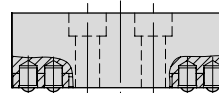

Za širino mm	80 890 ...
	EUR Y4
100	4,60 010
125	3,50 012
160	35,00 013

Komplet pokrovov

NCG NCG 5AC

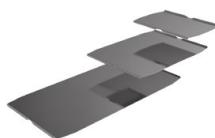

Za širino mm	80 890 ...
	EUR Y4
100	27,10 442
125	31,00 443
160	32,40 444

Vzmetni pritisni nastavek za zaščitno ploščo

NCG



Za širino mm	80 890 ...
	EUR Y4
100/125	2,30 008
160	2,30 014

Pregled pribora za sisteme

Vpenjalna ročica

▲ Vključno s priborom za upravljanje

NCG	NCG 5A
H5G	



Za širino mm	DRVS mm	80 890 ...
100/125/160	14	EUR Y4 128,00 501

Hitro vpenjanje

▲ Za hitrejše nastavljanje širine
vpenjanja s snemljivo ročico

NCG	NCG 5AC
-----	------------



Za širino mm	80 890 ...
100	EUR Y4 63,20 550
125/160	75,10 551

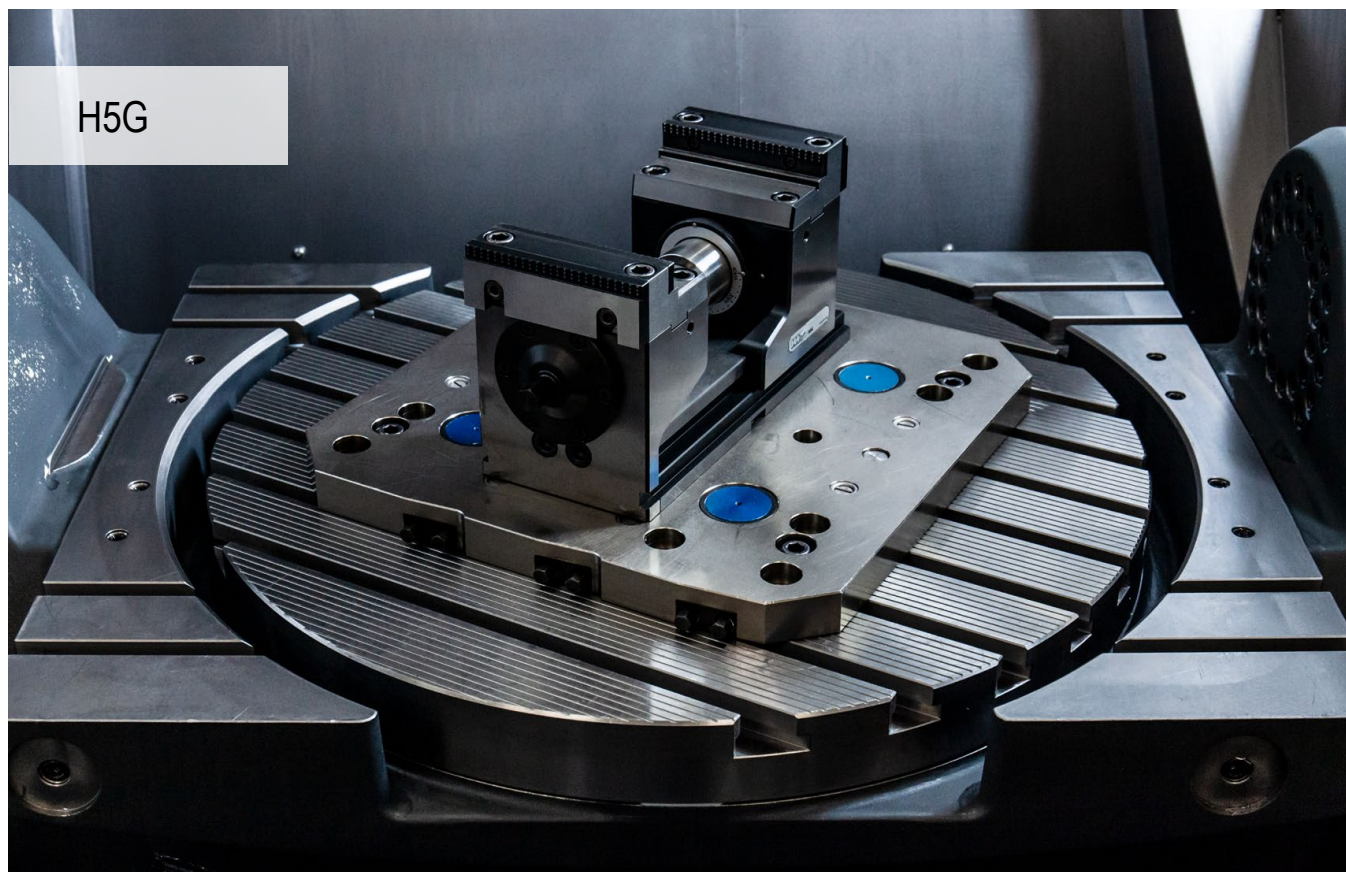

Vpenjalni sistem, optimiziran za 5-osno obdelavo

Vpenjalni sistem z ojačitvijo sile za »pravo«, kompletno in simultano, 5-osno obdelavo. 1- in 2-stranska obdelava z vpenjanjem na vlek in vpenjalno silo 40 kN neposredno na obdelovancu.

Prednosti za vas:

- ▲ Hitra preureditev – nastavitve v nekaj sekundah čez celotno območje vpenjanja
- ▲ Hitro pozicioniranje z MNG na strojni mizi brez vmesne plošče
- ▲ Brezstopensko nastavljiva vpenjalna sila od 4 do 40 kN
- ▲ 160-stopinjsko hitro vpenjanje
- ▲ Obračanje čeljusti – preprosta in hitra menjava čeljusti s 4 vijaki
- ▲ Preprosto čiščenje, v celoti zaščiteno vreteno
- ▲ Obsežen program modularnih čeljusti



Vpenjanje/usmerjanje:

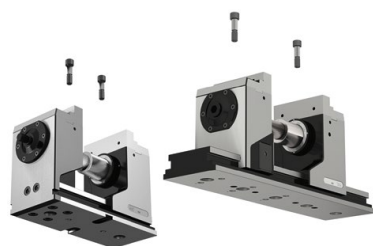

Vpenjanje z dvema vijakoma za namestitev
Ø 12,7 / M12 Kataloška št. 80 895 019



Usmerjanje s preciznimi utornimi maticami
20^{H7} v osnovnem telesu (H5G) in kompleti za
usmerjanje 14/16/18 v T-utoru strojne mize.
Vpetje z vpenjalnimi sponami.



Usmerjanje in vpenjanje z vpenjalnim sistemom
z ničelno točko MNG (2-3 vpenjalni čepi).
Po izbiri: Izvrtine za pozicioniranje in pritrtilne
izvrtine po želji stranke.

Usmeritev podaljška osnovnega telesa:



- ▲ Prosta namestitev podaljška osnovnega telesa
- ▲ Razdalja do primarnega osnovnega telesa 0,2–10 mm
- ▲ Potisnite pomično nosilno čeljust čez obe osnovni telesi
- ▲ Usmerite podaljšek osnovnega telesa vzporedno s primarnim osnovnim telesom
- ▲ Pritrdite podaljšek osnovnega telesa

Namestitev podaljška vlečnega droga:

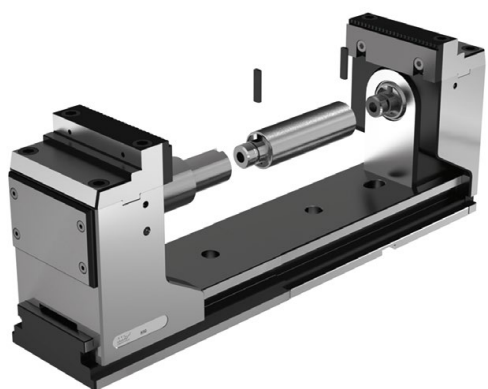

- ▲ Namestite podaljšek osnovnega telesa (za usmeritev glejte zgoraj)
- ▲ Privijte podaljšek vlečnega droga na vreteno
- ▲ Vstavite prvo varovanje pred zasukom
- ▲ Potisnite pomično nosilno čeljust na podaljšek osnovnega telesa
- ▲ Povežite podaljšan vlečni drog s fiksno nosilno čeljustjo
- ▲ Vstavite drugo varovanje pred zasukom

Način delovanja mobilne fiksne čeljusti:

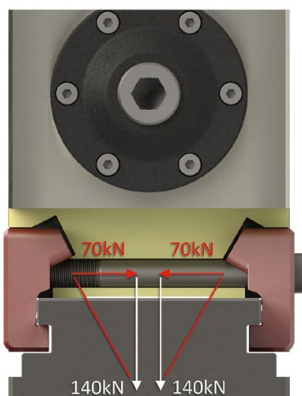

Dvojno delujoč vijak = dvojna sila
Poševne površine = dvojna sila

Pri H5G-Z in H5G-Z-S lahko obe osnovni čeljusti poljubno prestavljate. Mobilno fiksno čeljust lahko z 1 ali 2 vijakoma (1 = H5G-Z/2 = H5G-Z-S) vnete na poljubnem mestu na osnovnem telesu (vijak zategnite z 90 Nm). Držalna sila fiksne čeljusti je skoraj enaka kot pri H5G, kjer je pritrjena s štirimi vijaki.

SoloClamp – H5G

- ▲ 5-osni primež s hitro nastavitvijo, višina izvedbe 174 mm
- ▲ Hitro vpetje s pogonsko ročico
- ▲ Vpenjanje z zgornjim vretenom za nastavljanje na vlek
- ▲ 100 % oklopljen
- ▲ Primež z vzdolžnimi in prečnimi utori 20 H7 in izvrtinami Ø 12 F7

Obseg dobave:

Primež, vklj. s 4 vpenjalnimi sponami, pogonsko ročico in vpenjalnim ključem

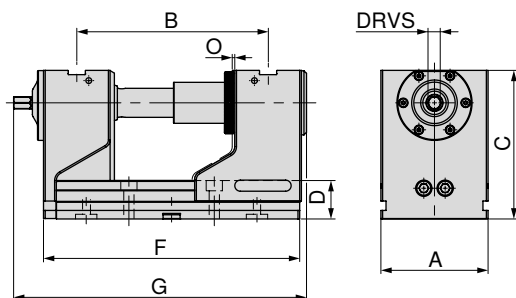
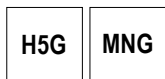

A	B	C	D	F	G	O	DRVS	MXC	WT
mm	mm	mm	mm	mm	mm	mm	mm	kN	kg
125	97 - 223	174	45	300	336,5	1	14	40	30,2

80 898 ...

EUR
Y4

3.180,00 125

SoloClamp – H5G

- ▲ 5-osni kompaktni primež, dolga izvedba, višina izvedbe 174 mm

H5G

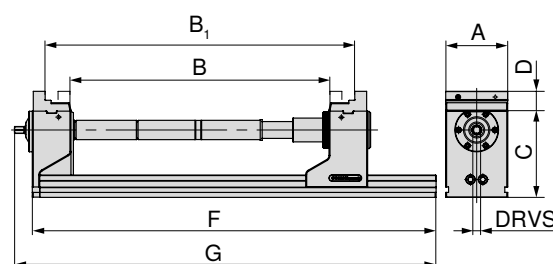
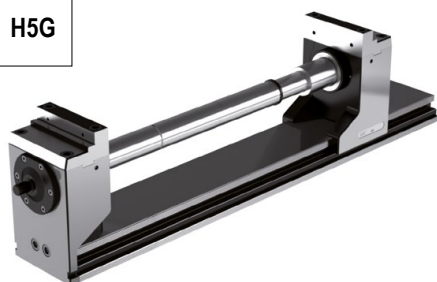

A	C	D	F	G	DRVS	Vpenjalna sila
mm	mm	mm	mm	mm	mm	kN
125	174	40	815	851	14	40

B	B ₁	Katalogška št.
0 – 126	123 – 251	80 898 125
125 – 252	248 – 374	80 898 125 + 80 898 826 + 80 898 725
250 – 376	372 – 499	80 898 125 + 80 898 827 + 80 898 725
375 – 501	498 – 624	80 898 125 + 80 898 826 + 80 898 827 + 80 898 725
500 – 626	622 – 749	80 898 125 + 2 x 80 898 827 + 80 898 725



H5G 125 mm lahko podaljšamo za največ 2 podaljška vlečnega droga po 250 mm. Pri vsakem podaljšku je prisotna pribl. 10-odstotna izguba vpenjalne sile. Osnovna plošča v dolgi izvedbi z želenimi izvrtinami je dobavljiva **samo po naročilu**.

Vodnik po primežih

Mere spodnje strani	27	Preglednice z merami za različne čeljusti	28–32
Pribor za sisteme	33–36	Vpenjalni sistem z ničelno točko MNG/PNG	134–163
Splošni pribor	164–183		

SoloClamp – H5G-S

- ▲ 5-osni primež s hitro nastavitvijo, višina izvedbe 125 mm
- ▲ Hitro vpetje s pogonsko ročico
- ▲ Vpenjanje z zgornjim vretenom za nastavljanje na vlek
- ▲ 100 % oklopljen
- ▲ Dolžina F = 300 mm s centriranjem \varnothing 25 H7
- ▲ Dolžina F = 265 mm s centriranjem \varnothing 32 H6
- ▲ Primež z vzdolžnimi in prečnimi utori 20 H7 in izvrtinami \varnothing 12 F7

Obseg dobave:

Primež, vklj. s 4 vpenjalnimi sponami, pogonsko ročico in vpenjalnim ključem

H5G-S

MNG

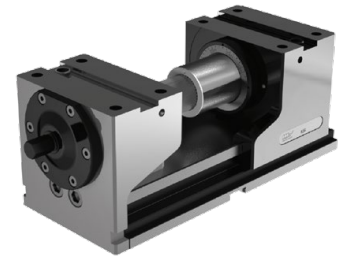
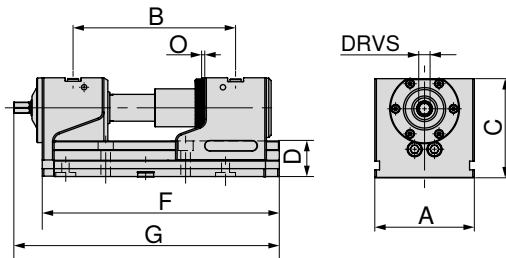

A	B	C	D	F	G	O	DRVS	MXC	WT
mm	mm	mm	mm	mm	mm	mm	mm	kN	kg
125	97 - 186	125	45	265	301,5	1	14	40	21,0
125	97 - 223	125	45	300	336,5	1	14	40	22,6

80 898 ...

EUR

Y4

2.910,00 123 ¹⁾

2.980,00 124

1) Ni primeren za MNG

SoloClamp – H5G-S

- ▲ 5-osni kompaktni primež, dolga izvedba, višina izvedbe 125 mm

H5G-S

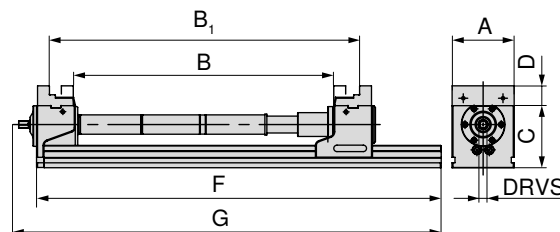
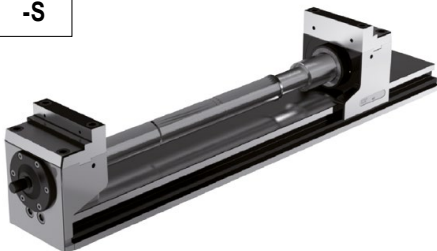

A	C	D	F	G	DRVS	Vpenjalna sila
mm	mm	mm	mm	mm	mm	kN
125	125	40	815	851	14	40

B	B ₁	Kataloška št.
0 – 126	123 – 250	80 898 124
125 – 251	248 – 374	80 898 124 + 80 898 826 + 80 898 725
250 – 376	372 – 499	80 898 124 + 80 898 827 + 80 898 725
375 – 501	498 – 624	80 898 124 + 80 898 826 + 80 898 827 + 80 898 725
500 – 626	622 – 749	80 898 124 + 2 x 80 898 827 + 80 898 725



H5G-S 125 mm lahko podaljšamo za največ 2 podaljška vlečnega droga po 250 mm. Pri vsakem podaljšku je prisotna pribl. 10-odstotna izguba vpenjalne sile. Osnovna plošča v dolgi izvedbi z zelenimi izvrtinami je dobavljiva **samo po naročilu**.

Vodnik po primežih

Mere spodnje strani	27	Preglednice z merami za različne čeljusti	28–32
Pribor za sisteme	33–36	Vpenjalni sistem z ničelno točko MNG/PNG	134–163
Splošni pribor	164–183		

SoloClamp – H5G-Z

- ▲ 5-osni primež z mobilno trdno čeljustjo, višina izvedbe 174 mm
- ▲ Hitro vpetje s pogonsko ročico
- ▲ Vpenjanje z zgornjim vretenom za nastavljanje na vlek
- ▲ 100 % oklopljen
- ▲ Vpenjanje na mizo stroja je možno z MNG/PNG ali neposredno skozi osnovno telo

Obseg dobave:

Vklj. z vpenjalnim ključem s šesterorobim nastavkom

H5G
-Z

MNG

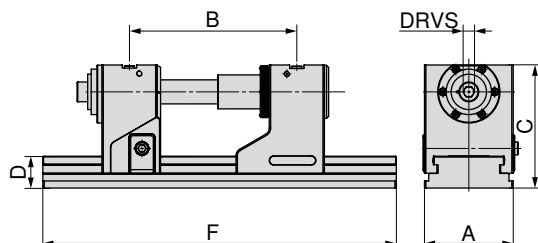

A	B $\pm 0,015$	C	D	F	DRVS	MXC	WT
mm	mm	mm	mm	mm	mm	kN	kg
125	131 - 246	174	45	330	14	40	32,5
125	131 - 352	174	45	430	14	40	36,0
125	131 - 422	174	45	500	14	40	38,5
125	131 - 552	174	45	630	14	40	43,0

80 907 ...

EUR
Y4

3.590,00 12800

3.650,00 125

3.810,00 126

4.130,00 127



→ Stran 36

Tukaj boste našli dodatne podaljške potezne palice, ki jih je treba uporabiti za doseganje največjih razponov vpenjanja.

SoloClamp – H5G-Z-S

- ▲ 5-osni primež z mobilno trdno čeljustjo, višina izvedbe 125 mm
- ▲ Hitro vpetje s pogonsko ročico
- ▲ Vpenjanje z zgornjim vretenom za nastavljanje na vlek
- ▲ 100 % oklopljen
- ▲ Vpenjanje na mizo stroja je možno z MNG/PNG ali neposredno skozi osnovno telo

Obseg dobave:

Vklj. z vpenjalnim ključem s šesterorobim nastavkom

H5G
-Z-S

MNG

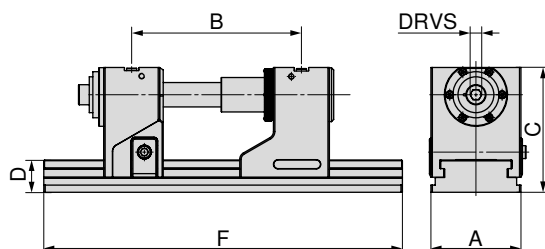

A	B $\pm 0,015$	C	D	F	DRVS	MXC	WT
mm	mm	mm	mm	mm	mm	kN	kg
125	131 - 246	125	45	330	14	40	24,5
125	131 - 352	125	45	430	14	40	28,5
125	131 - 422	125	45	500	14	40	30,5
125	131 - 552	125	45	630	14	40	35,5

80 907 ...

EUR
Y4

3.380,00 22500

3.430,00 22600

3.610,00 22700

3.930,00 22800

Mere spodnje strani za H5G/H5G-Z

Širina osnovnega telesa 125 mm
in dolžina 265 mm

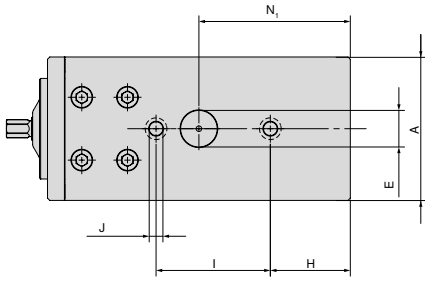

A	E _{H6}	H	I _{±0,015}	J _{F7}	N ₁
mm	mm	mm	mm	mm	mm
125	32	70	100	12	132,5

Širina osnovnega telesa 125 mm
in dolžina 430 mm

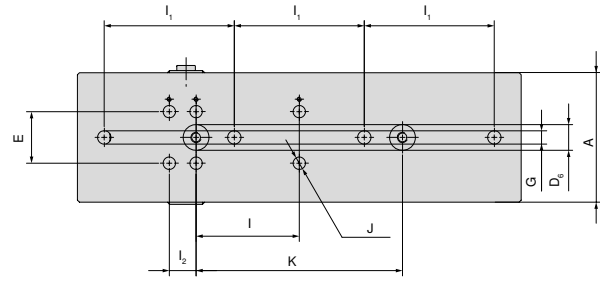

A	E _{±0,01}	I _{1 ±0,3}	I ₂	I _{±0,015}	K _{±0,015}	J _{H7}	G	D _{6 H6}
mm	mm	mm	mm	mm	mm	mm	mm	mm
125	50	126	26	100	200	12	13	25



H5G z dolžino 265 mm ni MNG kompatibilna.

Širina osnovnega telesa 125 mm
in dolžina 300 mm

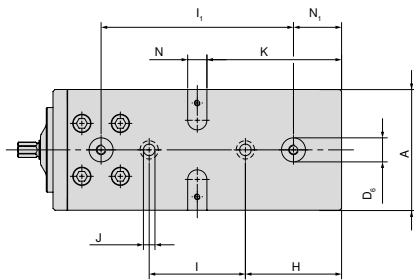

A	D _{6 H7}	H	I _{±0,015}	J _{F7}	K	N _{H7}	I _{1 ±0,015}	N ₁
mm	mm	mm	mm	mm	mm	mm	mm	mm
125	25	100	100	12	140	20	200	50

Širina osnovnega telesa 125 mm
in dolžina 500 mm

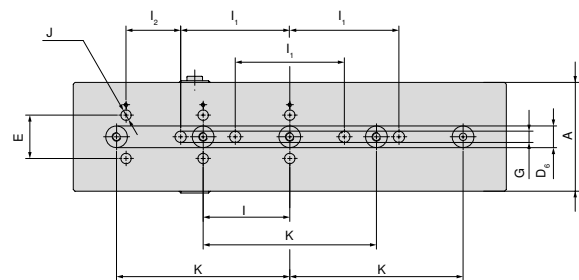

A	E _{±0,01}	I _{1 ±0,3}	I _{±0,015}	K _{±0,015}	I ₂	G	D _{6 H6}	J _{H7}
mm	mm	mm	mm	mm	mm	mm	mm	mm
125	50	126	100	200	63	13	25	12

Širina osnovnega telesa 125 mm
in dolžina 330 mm

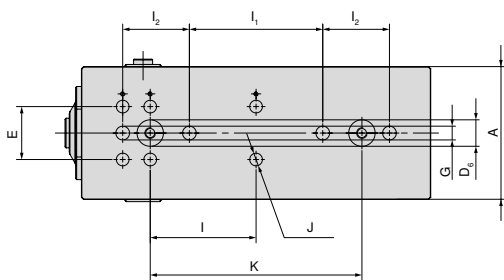

A	E _{±0,01}	I _{±0,015}	I ₂	I _{1 ±0,3}	D _{6 H6}	J _{H7}	K _{±0,015}	G
mm	mm	mm	mm	mm	mm	mm	mm	mm
125	50	100	26	126	25	12	200	13

Širina osnovnega telesa 125 mm
in dolžina 630 mm

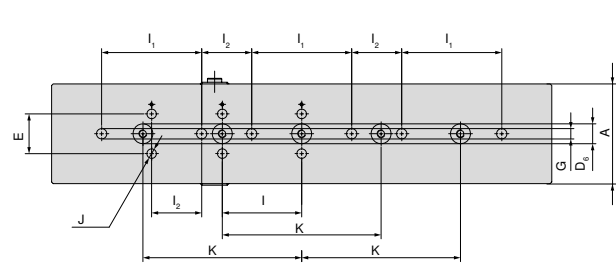

A	E _{±0,01}	I _{1 ±0,3}	I ₂	I _{±0,015}	K _{±0,015}	G	D _{6 H6}	J _{H7}
mm	mm	mm	mm	mm	mm	mm	mm	mm
125	50	126	63	100	200	13	25	12

Preglednica z merami H5G/H5G-S za različne čeljusti

S kombiniranimi čeljustmi

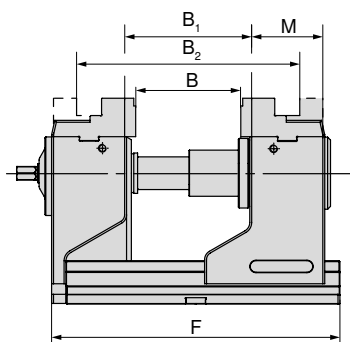

F	B	B ₁	B ₂	M	Kataloška št.
mm	mm	mm	mm	mm	Sistemske čeljusti
265	0 - 89	22 - 112	123 - 212	76	80 898 225
300	0 - 126	22 - 149	123 - 249	76	80 898 225

H5G

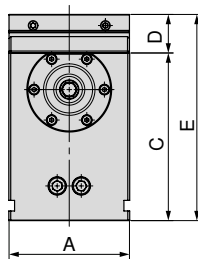

A	C	D	E
mm	mm	mm	mm
-	-	-	-
125	174	40	214

H5G-S

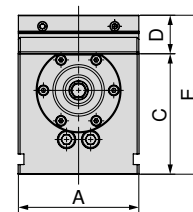

A	C	D	E
mm	mm	mm	mm
125	125	40	165
125	125	40	165

S čeljustnimi nastavki 5A, širina čeljusti 65 mm

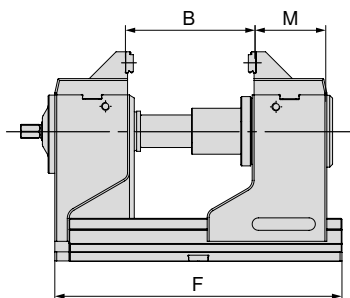

F	B	M	Kataloška št.
mm	mm	mm	Sistemske čeljusti
265	16 - 105	79,5	80 898 325
300	16 - 142	79,5	80 898 325

H5G

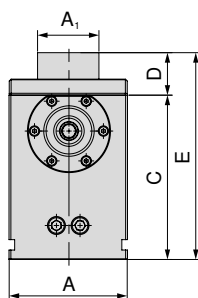

A	A ₁	C	D	E
mm	mm	mm	mm	mm
-	-	-	-	-
125	65	174	45	219

H5G-S

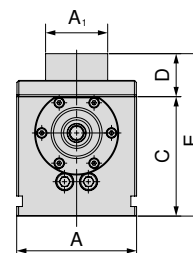

A	A ₁	C	D	E
mm	mm	mm	mm	mm
125	65	125	45	170
125	65	125	45	170

S čeljustnimi nastavki 5A, širina čeljusti 125 mm

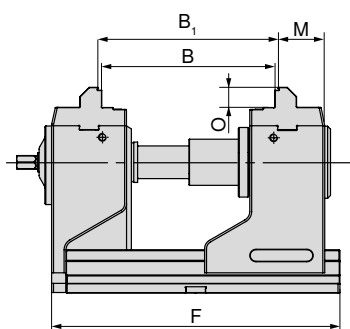

F	B	B ₁	O	M	Kataloška št.
mm	mm	mm	mm	mm	Sistemske čeljusti
265	74 - 162	80 - 168	21	49	80 907 300
300	74 - 199	80 - 205	21	49	80 907 300

H5G

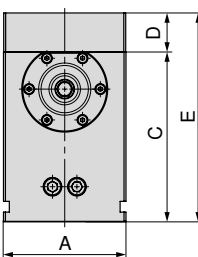

A	C	D	E
mm	mm	mm	mm
-	-	-	-
125	174	40	214

H5G-S

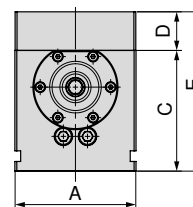

A	C	D	E
mm	mm	mm	mm
125	125	40	165
125	125	40	165

Preglednica z merami H5G/H5G-S za različne čeljusti

S čeljustmi v mehki izvedbi

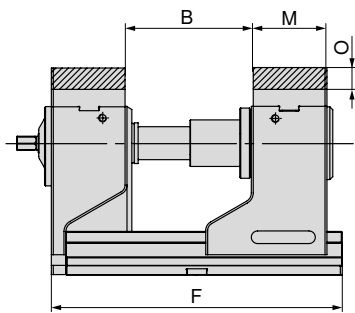

F	B	O	M	Kataloška št.
mm	mm	mm	mm	Sistemske čeljusti
265	23 - 112	22	76	80 898 625
300	23 - 149	22	76	80 898 625

H5G

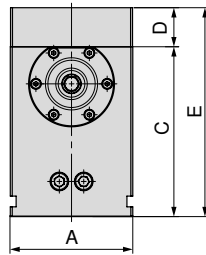

A	C	D	E
mm	mm	mm	mm
-	-	-	-
125	174	40	214

H5G-S

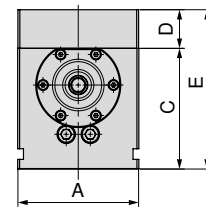

A	C	D	E
mm	mm	mm	mm
125	125	40	165
125	125	40	165

Z obrnljivimi čeljustmi, stopnja 3 mm

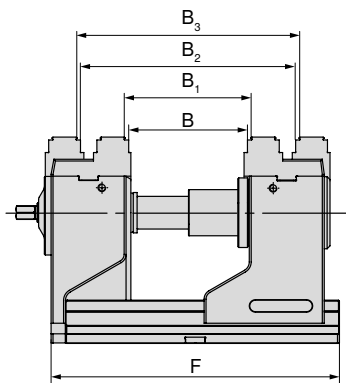

F	B	B ₁	B ₂	B ₃	Kataloška št.
mm	mm	mm	mm	mm	Sistemske čeljusti
265	17 - 106	23 - 112	117 - 206	123 - 212	80 898 35000
300	17 - 140	23 - 146	117 - 240	123 - 246	80 898 35000

H5G

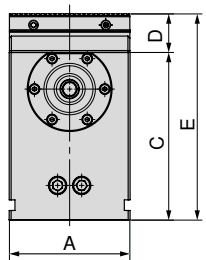

A	C	D	E
mm	mm	mm	mm
-	-	-	-
125	174	40	214

H5G-S

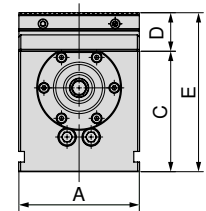

A	C	D	E
mm	mm	mm	mm
125	125	40	165
125	125	40	165

Z vrtljivo in adaptersko ploščo

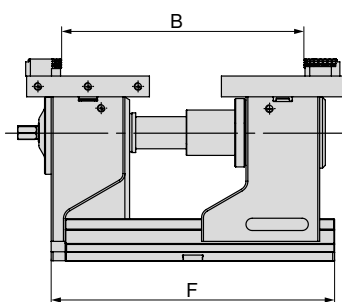

F	B	Kataloška št.
mm	mm	Sistemske čeljusti
265	17 - 236	80 898 525 + 80 898 425
300	17 - 274	80 898 525 + 80 898 425

H5G

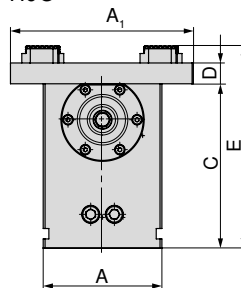

A	A ₁	C	D	E
mm	mm	mm	mm	mm
-	-	-	-	-
125	192	174	22	214

H5G-S

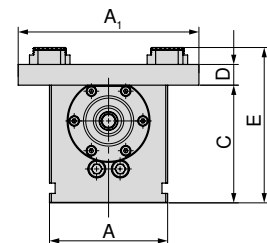

A	A ₁	C	D	E
mm	mm	mm	mm	mm
125	192	125	22	165
125	192	125	22	165

Preglednica z merami H5G/H5G-S za različne čeljusti

S 6-stopenjskim sistemom čeljusti

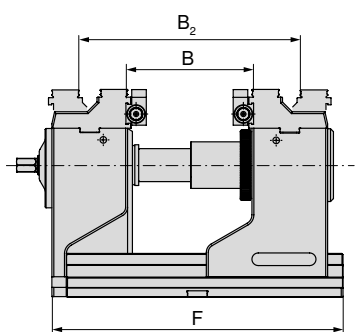

F	B	B ₂	O	M	Kataloška št. Sistemske čeljusti
265	39-115	119-191	22	76	80 898 230
300	39-152	119-228	22	76	80 898 230

H5G

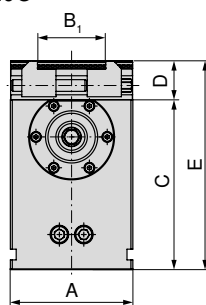

A	B ₁	C	D	E
-	-	-	-	-
125	37-101	174	40	214

H5G-S

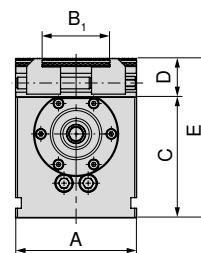

A	B ₁	C	D	E
125	37-101	125	40	165
125	37-101	125	40	165

Preglednica z merami H5G-Z/-S za različne čeljusti

S kombiniranimi čeljustmi

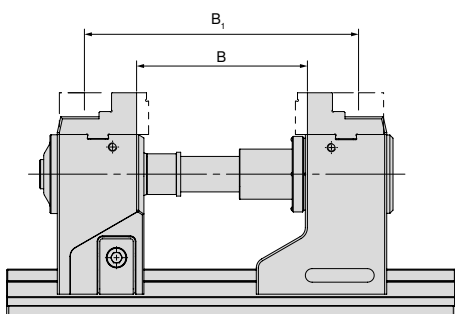

Različica	B	B ₁	Kataloška št. Sistemske čeljusti
H5G-Z	57-182	157-282	80 898 225
H5G-Z-S	47-172	147-272	80 898 225

H5G-Z

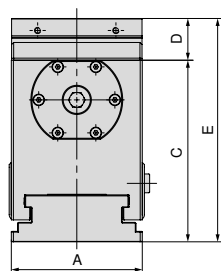

A	C	D	E
125	174	40	214
-	-	-	-

H5G-Z-S

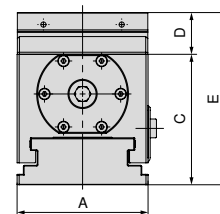

A	C	D	E
-	-	-	-
125	125	40	165

Z nastavkom 5A za stopničaste čeljusti

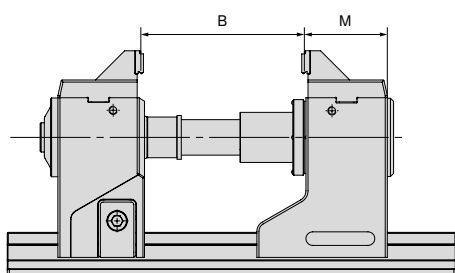

Različica	B	M	Kataloška št. Sistemske čeljusti
H5G-Z	50-175	74	80 898 325
H5G-Z-S	40-165	74	80 898 325

H5G-Z

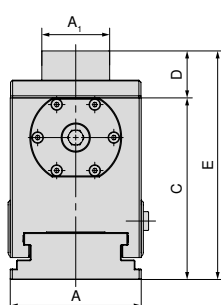

A	A ₁	C	D	E
125	65	174	45	214
-	-	-	-	-

H5G-Z-S

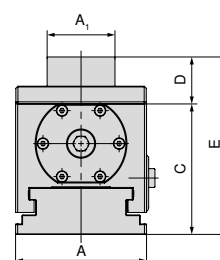

A	A ₁	C	D	E
-	-	-	-	-
125	65	125	45	165

Preglednica z merami H5G-Z/-S za različne čeljusti

Z obrnljivo čeljustjo, prijemalo 3 mm in stopnica 16 mm, gladka

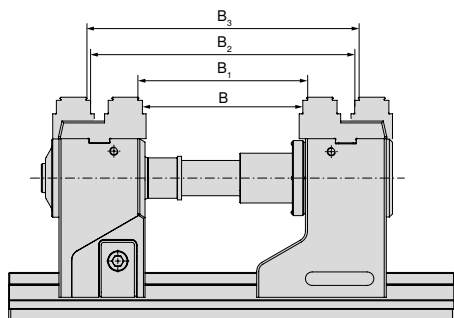

Različica	B mm	B ₁ mm	B ₂ mm	B ₃ mm	Katalogška št. Sistemske čeljusti
H5G-Z	48-173	54-179	148-273	154-279	2 x 80 898 35000
H5G-Z-S	38-173	44-169	138-263	144-269	2 x 80 898 35000

H5G-Z

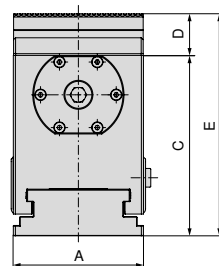

A mm	C mm	D mm	E mm
125	174	40	214
-	-	-	-

H5G-Z-S

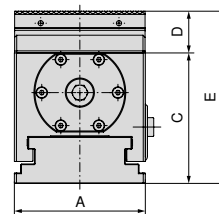

A mm	C mm	D mm	E mm
-	-	-	-
125	125	40	165

S čeljustnim nastavkom 5A, širina čeljusti 125 mm

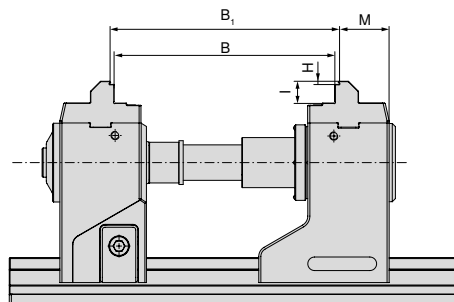

Različica	B mm	B ₁ mm	H mm	I mm	M mm	Katalogška št. Sistemske čeljusti
H5G-Z	105-230	111-236	3	21	48,7	2 x 80 907 300
H5G-Z-S	95-220	101-226	3	21	48,7	2 x 80 907 300

H5G-Z

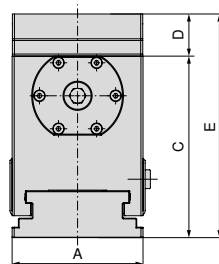

A mm	C mm	D mm	E mm
125	174	40	214
-	-	-	-

H5G-Z-S

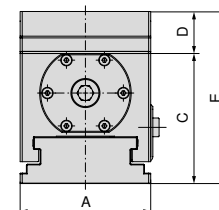

A mm	C mm	D mm	E mm
-	-	-	-
125	125	40	165

S čeljustmi v mehki izvedbi

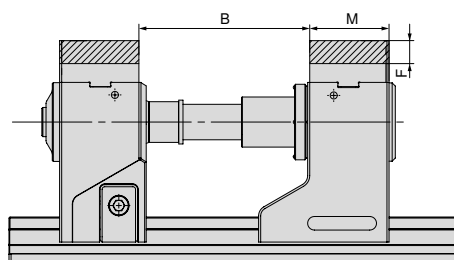

Različica	B mm	F mm	M mm	Katalogška št. Sistemske čeljusti
H5G-Z	57-182	22	76	80 898 625
H5G-Z-S	47-172	22	76	80 898 625

H5G-Z

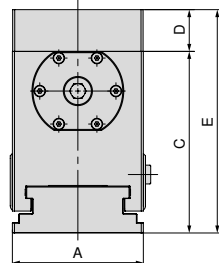

A mm	C mm	D mm	E mm
125	174	40	214
-	-	-	-

H5G-Z-S

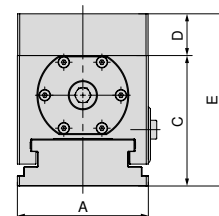

A mm	C mm	D mm	E mm
-	-	-	-
125	125	40	165

Preglednica z merami H5G-Z/-S za različne čeljusti

Z vrtljivo in adaptersko ploščo

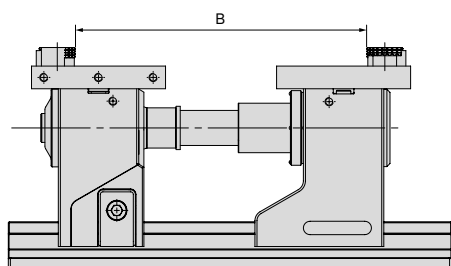

Različica	B mm	Kataloška št. Sistemske čeljusti
H5G-Z	11 - 300	80 898 525 + 80 898 425
H5G-Z-S	11 - 290	80 898 525 + 80 898 425

H5G-Z

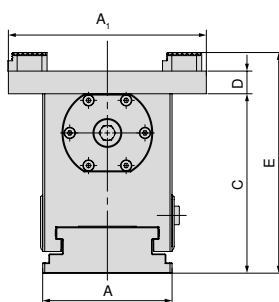

A mm	A ₁ mm	C mm	D mm	E mm
125	192	174	40	214
-	-	-	-	-

H5G-Z-S

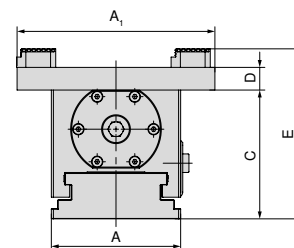

A mm	A ₁ mm	C mm	D mm	E mm
-	-	-	-	-
125	192	125	40	165

S 6-stopenjskim sistemom čeljusti

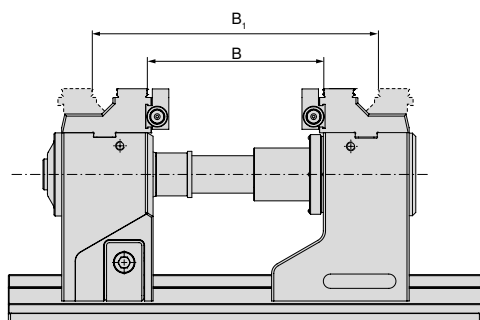

Različica	B mm	B ₂ mm	Kataloška št. Sistemske čeljusti
H5G-Z	52 - 177	152 - 277	80 898 230
H5G-Z-S	42 - 167	142 - 267	80 898 230

H5G-Z

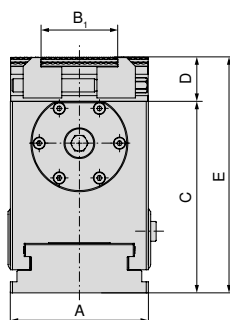

A mm	B ₁ mm	C mm	D mm	E mm
125	37 - 101	174	40	214
-	-	-	-	-

H5G-Z-S

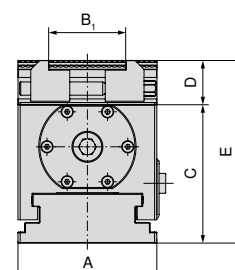

A mm	B ₁ mm	C mm	D mm	E mm
-	-	-	-	-
125	37 - 101	125	40	165



Območja vpenjanja veljajo tudi za osnovna telesa širine 500 mm in 630 mm. Območja vpenjanja je mogoče povečati s podaljšanjem potezne palice. Navedena območja vpenjanja je delno mogoče izvesti samo s čeljustnimi nastavki.

Pregled sistemov čeljusti

5-osna zgornja stopničasta čeljust

- ▲ Vklj. z nastavkom 125/65 mm in 3 mm prijemalom stopničaste čeljusti
- ▲ Cena za kos

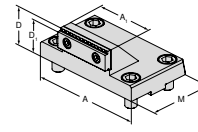

Za širino primeža	A	A ₁	D	D ₁	D ₂	E	M	M ₁	M ₂
125	125	65	45	42			76		

EUR

Y4

377,00

80 898 325

NCG	H5G / -S / -Z	X5G-Z / -S	ESG 4	ESG 5	HDG 2	ZSG 4	ZSG mini	DSG 4	Verso	HSG
	●									

5-osna zgornja čeljust

- ▲ Izboljšan dostop s posneto hrbtno stranjo
- ▲ Cena za kos

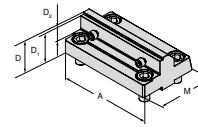

Za širino primeža	A	A ₁	D	D ₁	D ₂	E	M	M ₁	M ₂
125	125		40	37	18		78		

EUR

Y4

354,00

80 907 300

NCG	H5G / -S / -Z	X5G-Z / -S	ESG 4	ESG 5	HDG 2	ZSG 4	ZSG mini	DSG 4	Verso	HSG
	●									

Kombinirana obrnljiva čeljust

- ▲ Za povečanje območja vpenjanja
- ▲ Cena za kos

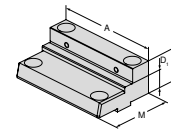

Za širino primeža	A	A ₁	D	D ₁	D ₂	E	M	M ₁	M ₂
125	125		40	22			76		

EUR

Y4

377,00

80 898 225

NCG	H5G / -S / -Z	X5G-Z / -S	ESG 4	ESG 5	HDG 2	ZSG 4	ZSG mini	DSG 4	Verso	HSG
	●									

Aluminijasta čeljust, mehka

- ▲ Za izdelavo oblikovnih čeljusti
- ▲ Cena za kos

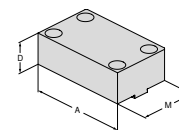

Za širino primeža	A	A ₁	D	D ₁	D ₂	E	M	M ₁	M ₂
125	125		40				76		

EUR

Y4

111,00

80 898 625

NCG	H5G / -S / -Z	X5G-Z / -S	ESG 4	ESG 5	HDG 2	ZSG 4	ZSG mini	DSG 4	Verso	HSG
	●									

Pregled sistemov čeljusti

Obrnljiva čeljust, prijemalo 3 mm, stopnica, gladka 16 mm, obojestranska

▲ Cena za kos

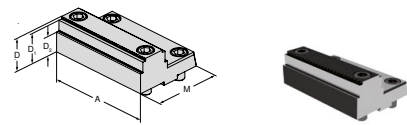

Za širino primeža	A	A ₁	D	D ₁	D ₂	E	M	M ₁	M ₂
125	125		40	37	24		82,5		

EUR

Y4

399,00

80 898 35000

NCG	H5G / -S / -Z	X5G-Z / -S	ESG 4	ESG 5	HDG 2	ZSG 4	ZSG mini	DSG 4	Verso	HSG
	●									

Vrtljiva čeljust, pomična

▲ Za vpenjanje 6-delnih obrnljivih čeljusti

▲ Cena za kos

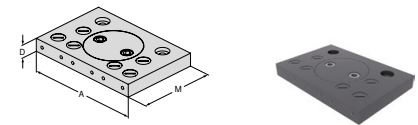

Za širino primeža	A	A ₁	D	D ₁	D ₂	E	M	M ₁	M ₂
125	192		22				130		

EUR

Y4

491,00

80 898 525

NCG	H5G / -S / -Z	X5G-Z / -S	ESG 4	ESG 5	HDG 2	ZSG 4	ZSG mini	DSG 4	Verso	HSG
	●									

Adapterska plošča, nepomična

▲ Za vpenjanje 6-delnih obrnljivih čeljusti

▲ Cena za kos

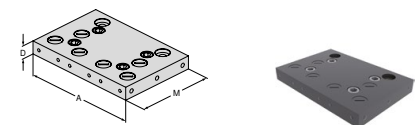

Za širino primeža	A	A ₁	D	D ₁	D ₂	E	M	M ₁	M ₂
125	192		22				130		

EUR

Y4

414,00

80 898 425

NCG	H5G / -S / -Z	X5G-Z / -S	ESG 4	ESG 5	HDG 2	ZSG 4	ZSG mini	DSG 4	Verso	HSG
	●									

6-delni čeljustni nastavek

▲ 1 = Gladka, prevlečena z volframovim karbidom

▲ 2 = Prijemalo s stopnico 3 mm

▲ 3 = Prijemalo s stopnico 8 mm

▲ 4 = Prijemalo s stopnico 18 mm

▲ 5 = Prijemalo, okroglo, s stopnico 8 mm

▲ 6 = Prijemalo, okroglo

▲ M_{najv.} = 60 Nm

▲ Vklj. s pritrdilnimi vijaki

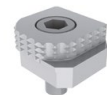
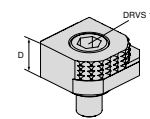

Za širino primeža	A	A ₁	D	D ₁	D ₂	E	M	M ₁	M ₂
			18						

EUR

Y4

80,60

80 892 246

NCG	H5G / -S / -Z	X5G-Z / -S	ESG 4	ESG 5	HDG 2	ZSG 4	ZSG mini	DSG 4	Verso	HSG
●	●	●	●			●		●	●	

Pregled sistemov čeljusti

6-delni čeljustni nastavek, s prijemalom iz karbidne trdine

- ▲ 1 = gladka
- ▲ 2 = karbidno prijemalo
- ▲ 3 = karbidno prijemalo s stopnico 3 mm
- ▲ 4 = karbidno prijemalo s stopnico 8 mm
- ▲ 5 = karbidno prijemalo, okroglo, s stopnico 8 mm
- ▲ 6 = karbidno prijemalo, okroglo
- ▲ vklj. s pritrdilnimi vijaki

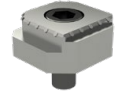
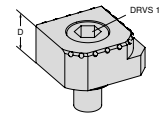

Za širino primeža	A	A ₁	D	D ₁	D ₂	E	M	M ₁	M ₂	EUR	Y4	NCG	H5G / -S / -Z	X5G-Z / -S	ESG 4	ESG 5	HDG 2	ZSG 4	ZSG mini	DSG 4	Verso	HSG	
			18							117,00	80 890 35300	●	●	●	●			●		●	●	●	

6-kratni sistem čeljusti za širino čeljusti 125 mm

Obseg dobave:

2 sistema čeljusti z 2 paroma prečnih čeljusti v izvedbi s T-utori, vklj. s pritrdilnimi vijaki

H5G
-S

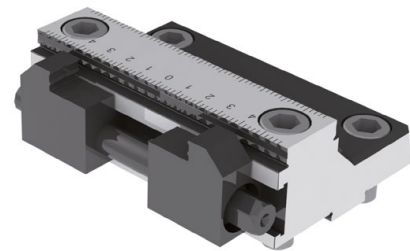
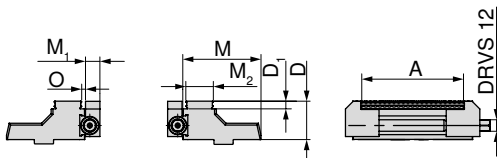



Za širino mm	A mm	D mm	D ₁ mm	M mm	M ₁ mm	M ₂ mm	O mm	WT kg	80 898 ...	EUR	Y4
125	37 - 101	40	8	81,5	15	28,7	3,2	4,5		1.760,00	230

Pregled pribora za sisteme

Podaljšek potezne palice

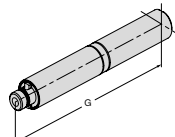
▲ Vklj. z varovalom pred zasukom

H5G	H5G-S		
H5G-Z			

G	80 898 ...
mm	EUR Y4
125	360,00 826
250	408,00 827



Mašilni čep

▲ Cena za kos

H5G-Z	

D ₁	80 907 ...
mm	EUR Y4
19	1,20 501

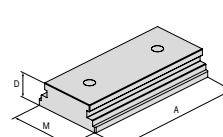
Osnovna plošča za podaljšanje

H5G		

A	D	M	80 898 ...
mm	mm	mm	EUR Y4
250	45	125,5	644,00 725



Vpenjalna ročica

▲ Vključno s priborom za upravljanje

NCG	NCG 5A	
H5G		

DRVS	80 890 ...
mm	EUR Y4
14	128,00 501

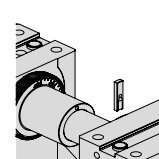
Varovalo pred zasukom

H5G	H5G-S		
H5G-Z	H5G-Z-S		

	80 898 ...
	EUR Y4
	12,40 024

Vpenjalna ročica z zglobom

▲ brez natičnega nastavka

H5G-Z	H5G-Z-S	
ESG 4	ESG mini	
ZSG 4		

Štirirobi	80 891 ...
1/2"	EUR Y4
	76,10 600

Pogonska ročica

▲ Za hitro nastavitvev

	H5G-Z	H5G-S	H5G
	X5G-Z	H5G-Z-S	

DRVS	80 907 ...	80 898 ...	80 898 ...
mm	EUR Y4	EUR Y4	EUR Y4
14	81,00 500	81,00 026	81,00 025

Natični nastavek

▲ Primerno za 1/2- ali 3/8-palčni štiriobnik

H5G-Z	ESG mini	
MSG 2	Verso	
MNG		

Štirirobi	DRVS	80 877 ...
1/2"	mm	EUR Y4
		18,20 214

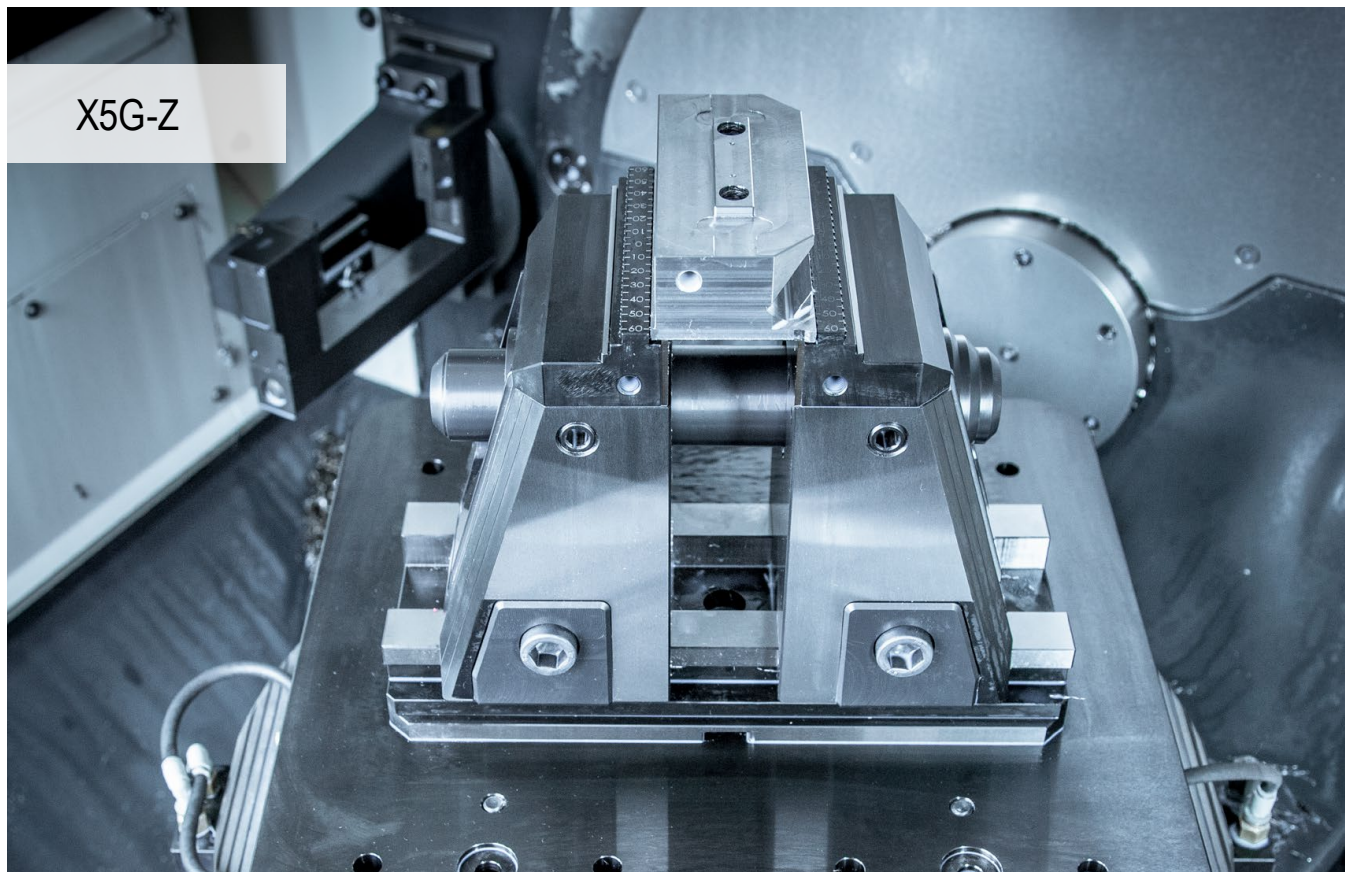

X5G-Z

Dovršena 5-osna obdelava

Preprosto rokovanje in integriran vlek navzdol za 6-stransko obdelavo. X5G-Z je novi 5-osni primež znamke CERATIZIT. Vse prednosti za optimalno ter preprosto 5- in 6-stransko obdelavo, združene v enem vpenjalnem sredstvu.

Prednosti za vas:

- ▲ Možnost 5- in 6-stranske obdelave z vpenjanjem ene od obeh nosilnih čeljusti
- ▲ Hitra menjava čeljusti brez orodja
- ▲ Najboljša dostopnost z vseh strani in velik osnovni vpenjalni hod 130 mm
- ▲ V celoti oklopljeno, mehansko vreteno
- ▲ Integrirano, notranje blaženje z elastomeri za čim večje zmanjšanje vibracij
- ▲ Obsežen program modularnih čeljusti



Vpenjanje/usmerjanje:



Vpenjanje z dvema vijakoma za namestitev
Ø 12_{H7} / M12 in vpenjalnimi vijaki
Kataloška št. 80 895 019



Usmerjanje s preciznimi utornimi maticami 20^{H7}
v osnovnem telesu v T-utoru strojne mize.
Vpetje z vpenjalnimi sponami.



Usmerjanje in vpenjanje z vpenjalnim sistemom
z ničelno točko MNG (2-3 vpenjalni čepi).
Po izbiri: Izvrtine za pozicioniranje in pritrdilne
izvrtine po želji stranke.

Vpenjalna sila:

Velikost		najv. zatezni vrtilni moment v Nm	Najv. vpenjalna sila v kN
X5G-Z	Vpenjanje surovcev	100	50
X5G-Z	Precizno vpenjanje	120	40
X5G-Z-S	Vpenjanje surovcev	100	50
X5G-Z-S	Precizno vpenjanje	120	34

Zatezni vrtilni moment/vpenjalna sila X5G-Z

Vpenjanje surovcev

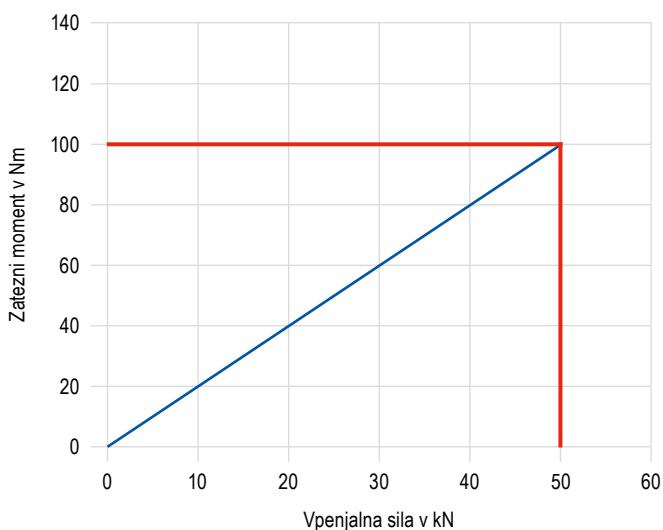

Precizno vpenjanje

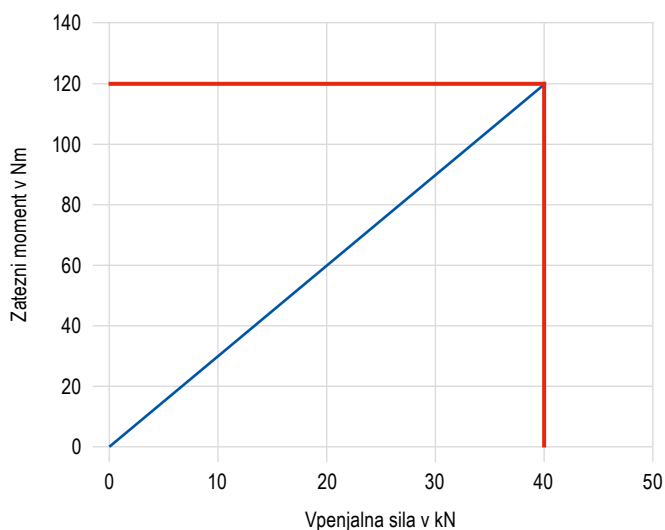

Zatezni vrtilni moment/vpenjalna sila X5G-Z-S

Vpenjanje surovcev

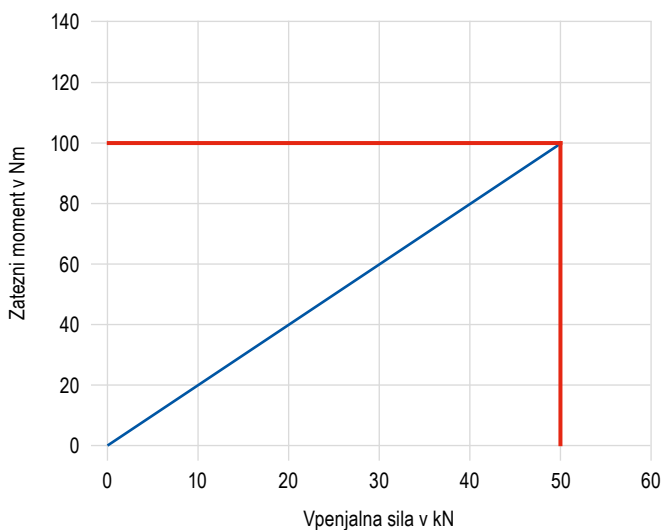

Precizno vpenjanje

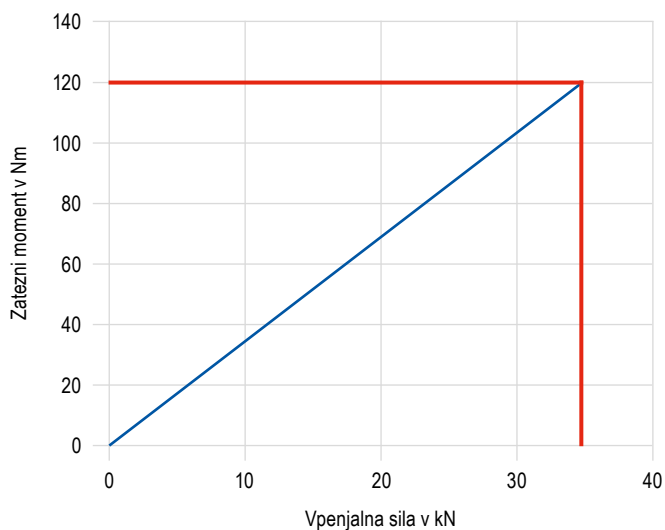

SoloClamp – X5G-Z

- ▲ mehanski 5-osni primež z mobilno trdno čeljustjo, višina 181 mm
- ▲ brez sistemskih čeljusti
- ▲ najboljša dostopnost
- ▲ mogoči sta 5- in 6-stranska obdelava
- ▲ Hitrovpenjalni sistem za čeljusti
- ▲ vpetje na strojno mizo mogoče z MNG/PNG ali neposredno z osnovnim telesom

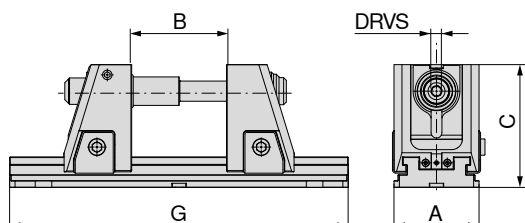
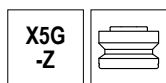

A	B	C	G	DRVS	MXC	WT	80 908 ...	
mm	mm	mm	mm	mm	kN	kg	EUR	
125	4 - 134	181	330	14	40	33,2	3.170,00	52500
125	4 - 234	181	430	14	40	36,1	3.400,00	52600
125	4 - 304	181	500	14	40	38,1	3.540,00	52700
125	4 - 434	181	630	14	40	41,8	3.800,00	52800
125	4 - 604	181	800	14	40	46,6	4.140,00	52900

Osnovni vpenjalni hod 130 mm

→ **Stran 48**
Tukaj boste našli dodatne podaljške potezne palice, ki jih je treba uporabiti za doseganje največjih razponov vpenjanja.

→ **Stran 42-44**
Tukaj boste našli tabele strukturnih mer za različne čeljusti.

Vodnik po primežih

Mere spodnje strani	41	Pribor za sisteme	45
Vpenjalni sistem z ničelno točko MNG/PNG	134-163	Splošni pribor	164-183

SoloClamp – X5G-Z-S

- ▲ mehanski 5-osni primež z mobilno trdno čeljustjo, višina 142 mm
- ▲ brez sistemskih čeljusti
- ▲ najboljša dostopnost
- ▲ mogoči sta 5- in 6-stranska obdelava
- ▲ Hitrovpenjalni sistem za čeljusti
- ▲ vpetje na strojno mizo mogoče z MNG/PNG ali neposredno z osnovnim telesom

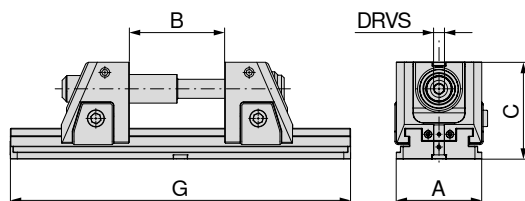
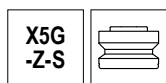

A	B	C	G	DRVS	MXC	WT	80 908 ...	
mm	mm	mm	mm	mm	kN	kg	EUR	
125	4 - 134	142	330	14	40	27,3	2.880,00	42500
125	4 - 234	142	430	14	40	30,2	3.110,00	42600
125	4 - 304	142	500	14	40	32,2	3.250,00	42700
125	4 - 434	142	630	14	40	35,9	3.510,00	42800
125	4 - 604	142	800	14	40	40,7	3.860,00	42900

Osnovni vpenjalni hod 130 mm

→ **Stran 48**
Tukaj boste našli dodatne podaljške potezne palice, ki jih je treba uporabiti za doseganje največjih razponov vpenjanja.

→ **Stran 42-44**
Tukaj boste našli tabele strukturnih mer za različne čeljusti.

Vodnik po primežih

Mere spodnje strani	41	Pribor za sisteme	45
Vpenjalni sistem z ničelno točko MNG/PNG	134-163	Splošni pribor	164-183

Mere spodnje strani za X5G-Z/-S

Širina osnovnega telesa 125 mm
in dolžina 330 mm

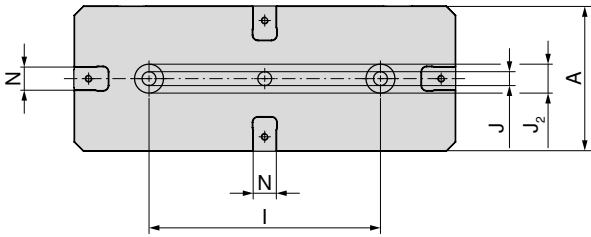

A	I _{±0,02}	J _{H7}	J _{2 H6}	N _{H7}
mm	mm	mm	mm	mm
125	200	12	25	20

Širina osnovnega telesa 125 mm
in dolžina 630 mm

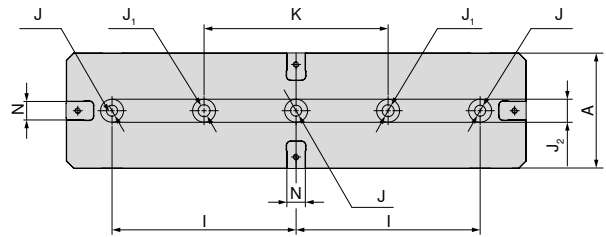

A	I _{±0,02}	J _{H7}	J ₁	J _{2 H6}	K _{±0,02}	N _{H7}
mm	mm	mm	mm	mm	mm	mm
125	200	12	13	25	200	20

Širina osnovnega telesa 125 mm
in dolžina 430 mm

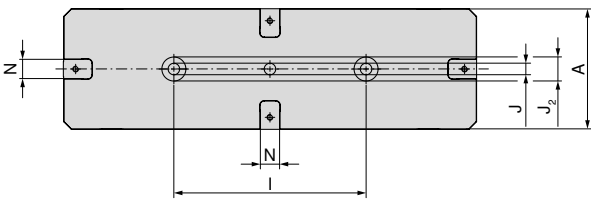

A	I _{±0,02}	J _{H7}	J _{2 H6}	N _{H7}
mm	mm	mm	mm	mm
125	200	12	25	20

Širina osnovnega telesa 125 mm
in dolžina 800 mm

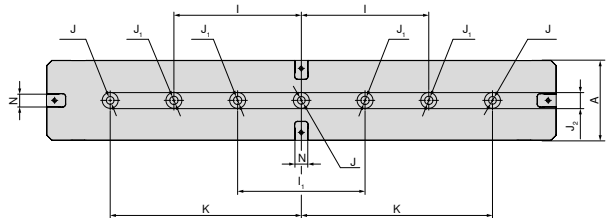

A	I _{±0,02}	I _{1 ±0,02}	J _{H7}	J ₁	J _{2 H6}	K _{±0,02}	N _{H7}
mm	mm	mm	mm	mm	mm	mm	mm
125	200	200	12	13	25	300	20

Širina osnovnega telesa 125 mm
in dolžina 500 mm

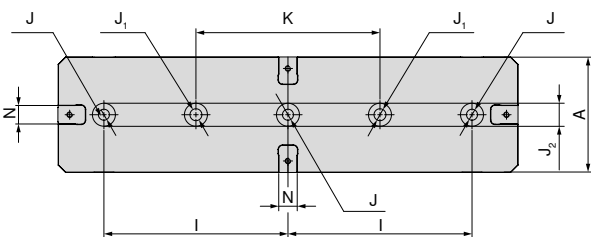

A	I _{±0,02}	J _{H7}	J ₁	J _{2 H6}
mm	mm	mm	mm	mm
125	200	12	13	25

Preglednica z merami X5G-Z/-S za različne čeljusti

Z obrnljivimi čeljustmi, stopnja 3 mm

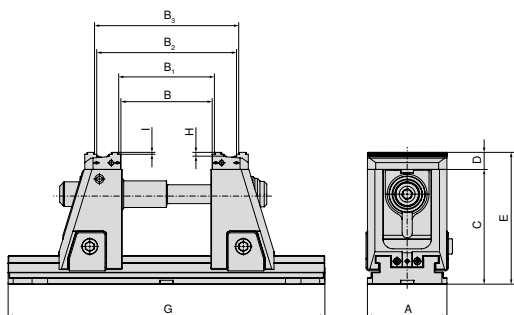

Tip	Podajšek potezne palice 430 mm 80 908 80000	Podajšek potezne palice 500 mm 80 908 80100	Podajšek potezne palice 630 mm 80 908 80200	Podajšek potezne palice 800 mm 80 908 80300	A	B	B ₁	B ₂	B ₃	C	D	E	G	H	I
80 908 52500					125	5-134	12-141	80-210	88-217	181	27	208	330	6	3
80 908 42500					125	5-134	12-141	80-210	88-217	142	27	169	330	6	3
80 908 52600	1 x				125	5-234	12-241	80-310	88-317	181	27	208	430	6	3
80 908 42600	1 x				125	5-234	12-241	80-310	88-317	142	27	169	430	6	3
80 908 52700	1 x	1 x			125	5-304	12-311	80-380	88-387	181	27	208	500	6	3
80 908 42700	1 x	1 x			125	5-304	12-311	80-380	88-387	142	27	169	500	6	3
80 908 52800	1 x	1 x	1 x		125	5-434	12-441	80-510	88-517	181	27	208	630	6	3
80 908 42800	1 x	1 x	1 x		125	5-434	12-441	80-510	88-517	142	27	169	630	6	3
80 908 52900	1 x	1 x	1 x	1 x	125	5-604	12-611	80-680	88-687	181	27	208	800	6	3
80 908 42900	1 x	1 x	1 x	1 x	125	5-604	12-611	80-680	88-687	142	27	169	800	6	3

Z obrnljivimi čeljustmi, stopnja 5 mm

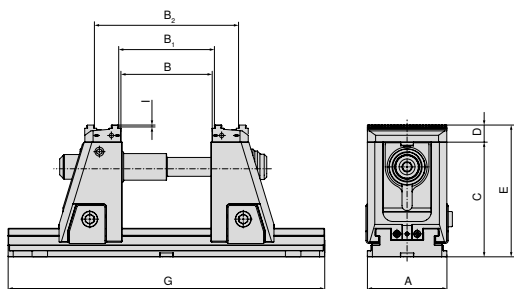

Tip	Podajšek potezne palice 430 mm 80 908 80000	Podajšek potezne palice 500 mm 80 908 80100	Podajšek potezne palice 630 mm 80 908 80200	Podajšek potezne palice 800 mm 80 908 80300	A	B	B ₁	B ₂	C	D	E	G	I
80 908 52500					125	5-134	12-141	88-217	181	27	208	330	5
80 908 42500					125	5-134	12-141	88-217	142	27	169	330	5
80 908 52600	1 x				125	5-234	12-241	88-317	181	27	208	430	5
80 908 42600	1 x				125	5-234	12-241	88-317	142	27	169	430	5
80 908 52700	1 x	1 x			125	5-304	12-311	88-387	181	27	208	500	5
80 908 42700	1 x	1 x			125	5-304	12-311	88-387	142	27	169	500	5
80 908 52800	1 x	1 x	1 x		125	5-434	12-441	88-517	181	27	208	630	5
80 908 42800	1 x	1 x	1 x		125	5-434	12-441	88-517	142	27	169	630	5
80 908 52900	1 x	1 x	1 x	1 x	125	5-604	12-611	88-687	181	27	208	800	5
80 908 42900	1 x	1 x	1 x	1 x	125	5-604	12-611	88-687	142	27	169	800	5



→ Stran 48

Tukaj boste našli ustrezne podajške potezne palice.

Preglednica z merami X5G-Z/-S za različne čeljusti

S stopničastimi čeljustmi, 5mm, oprijem z HM zobmi

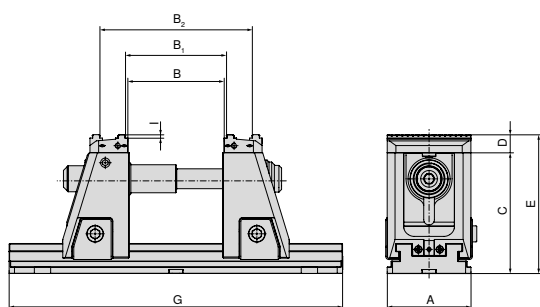

Tip	Podaljšek potezne palice 430 mm 80 908 80000	Podaljšek potezne palice 500 mm 80 908 80100	Podaljšek potezne palice 630 mm 80 908 80200	Podaljšek potezne palice 800 mm 80 908 80300	A	B	B ₁	B ₂	C	D	E	G	I
80 908 52500					125	5-134	12-141	88-217	181	27	208	330	5
80 908 42500					125	5-134	12-141	88-217	142	27	169	330	5
80 908 52600	1 x				125	5-234	12-241	88-317	181	27	208	430	5
80 908 42600	1 x				125	5-234	12-241	88-317	142	27	169	430	5
80 908 52700	1 x	1 x			125	5-304	12-311	88-387	181	27	208	500	5
80 908 42700	1 x	1 x			125	5-304	12-311	88-387	142	27	169	500	5
80 908 52800	1 x	1 x	1 x		125	5-434	12-441	88-517	181	27	208	630	5
80 908 42800	1 x	1 x	1 x		125	5-434	12-441	88-517	142	27	169	630	5
80 908 52900	1 x	1 x	1 x	1 x	125	5-604	12-611	88-687	181	27	208	800	5
80 908 42900	1 x	1 x	1 x	1 x	125	5-604	12-611	88-687	142	27	169	800	5

Z mehкими čeljustmi, jeklo

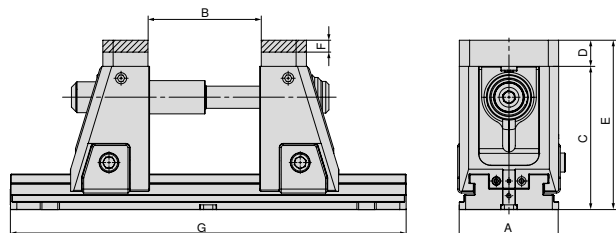
Katalogska št.
Sistemske čeljusti

2 x 80 909 31200

Tip	Podaljšek potezne palice 430 mm 80 908 80000	Podaljšek potezne palice 500 mm 80 908 80100	Podaljšek potezne palice 630 mm 80 908 80200	Podaljšek potezne palice 800 mm 80 908 80300	A	B	C	D	E	F	G
80 908 52500					125	4-134	181	33	214	15	330
80 908 42500					125	4-134	142	33	175	15	330
80 908 52600	1 x				125	4-234	181	33	214	15	430
80 908 42600	1 x				125	4-234	142	33	175	15	430
80 908 52700	1 x	1 x			125	4-304	181	33	214	15	500
80 908 42700	1 x	1 x			125	4-304	142	33	175	15	500
80 908 52800	1 x	1 x	1 x		125	4-434	181	33	214	15	630
80 908 42800	1 x	1 x	1 x		125	4-434	142	33	175	15	630
80 908 52900	1 x	1 x	1 x	1 x	125	4-604	181	33	214	15	800
80 908 42900	1 x	1 x	1 x	1 x	125	4-604	142	33	175	15	800



→ Stran 48

Tukaj boste našli ustrezne podaljške potezne palice.

Preglednica z merami X5G-Z/-S za različne čeljusti

Zamenljive z reliefnim profilom

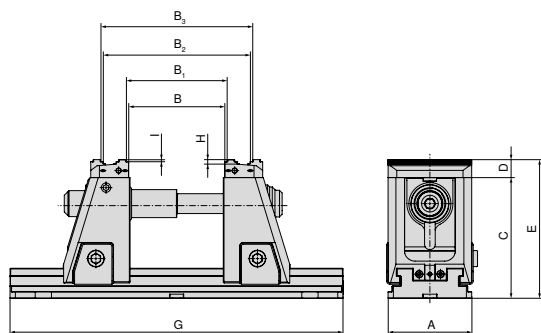
Kataloška št.
Sistemske čeljusti

2 x 80 908 31200

Tip	Podaljšek potezne palice 430 mm 80 908 80000	Podaljšek potezne palice 500 mm 80 908 80100	Podaljšek potezne palice 630 mm 80 908 80200	Podaljšek potezne palice 800 mm 80 908 80300	A	B	B ₁	B ₂	B ₃	C	D	E	G	H	I
80 908 52500					125	5-134	12-141	82-210	89-217	181	27	208	330	6	3
80 908 42500					125	5-134	12-141	82-210	89-217	142	27	169	330	6	3
80 908 52600	1 x				125	5-234	12-241	82-310	89-317	181	27	208	430	6	3
80 908 42600	1 x				125	5-234	12-241	82-310	89-317	142	27	169	430	6	3
80 908 52700	1 x	1 x			125	5-304	12-311	82-380	89-387	181	27	208	500	6	3
80 908 42700	1 x	1 x			125	5-304	12-311	82-380	89-387	142	27	169	500	6	3
80 908 52800	1 x	1 x	1 x		125	5-434	12-441	82-510	89-517	181	27	208	630	6	3
80 908 42800	1 x	1 x	1 x		125	5-434	12-441	82-510	89-517	142	27	169	630	6	3
80 908 52900	1 x	1 x	1 x	1 x	125	5-604	12-611	82-680	89-687	181	27	208	800	6	3
80 908 42900	1 x	1 x	1 x	1 x	125	5-604	12-611	82-680	89-687	142	27	169	800	6	3

Z vrtljivo in adaptersko ploščo

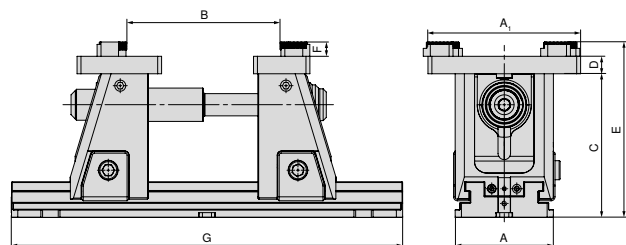
Kataloška št.
Sistemske čeljusti

80 909 31500 + 80 909 31300

Tip	Podaljšek potezne palice 430 mm 80 908 80000	Podaljšek potezne palice 500 mm 80 908 80100	Podaljšek potezne palice 630 mm 80 908 80200	Podaljšek potezne palice 800 mm 80 908 80300	A	B	C	D	E	F	G
80 908 52500					125	42-210	181	22	221	18	330
80 908 42500					125	42-210	142	22	182	18	330
80 908 52600	1 x				125	42-310	181	22	221	18	430
80 908 42600	1 x				125	42-310	142	22	182	18	430
80 908 52700	1 x	1 x			125	42-380	181	22	221	18	500
80 908 42700	1 x	1 x			125	42-380	142	22	182	18	500
80 908 52800	1 x	1 x	1 x		125	42-510	181	22	221	18	630
80 908 42800	1 x	1 x	1 x		125	42-510	142	22	182	18	630
80 908 52900	1 x	1 x	1 x	1 x	125	42-680	181	22	221	18	800
80 908 42900	1 x	1 x	1 x	1 x	125	42-680	142	22	182	18	800



→ Stran 48

Tukaj boste našli ustrezne podaljške potezne palice.

Pregled sistemov čeljusti

Obrnljiva čeljust, prijemalna, 3 mm

▲ Cena za kos

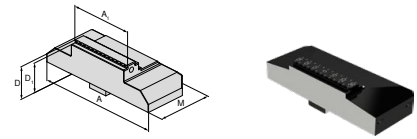

Za širino primeža	A	A ₁	D	D ₁	D ₂	E	M	M ₁	M ₂	EUR	Y4	NCG	H5G / -S / -Z	X5G-Z / -S	ESG 4	ESG 5	HDG 2	ZSG 4	ZSG mini	DSG 4	Veriso	HSG		
125	125	40	27	24			57			302,00	80 908 30300			●										
125	125	65	27	24			57			314,00	80 908 30200			●										
125	125	80	27	24			57			314,00	80 908 30100			●										
125	125	125	27	24			57			324,00	80 908 30000			●										

Obrnljiva čeljust, prijemalna, 5 mm

▲ Cena za kos

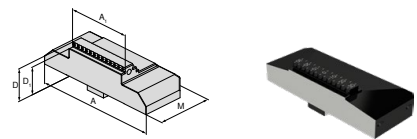

Za širino primeža	A	A ₁	D	D ₁	D ₂	E	M	M ₁	M ₂	EUR	Y4	NCG	H5G / -S / -Z	X5G-Z / -S	ESG 4	ESG 5	HDG 2	ZSG 4	ZSG mini	DSG 4	Veriso	HSG		
125	125	40	27	22			57			302,00	80 908 30700			●										
125	125	65	27	22			57			314,00	80 908 30600			●										
125	125	80	27	22			57			314,00	80 908 30500			●										
125	125	125	27	22			57			324,00	80 908 30400			●										

Obrnljiva čeljust, gladka

▲ Cena za kos

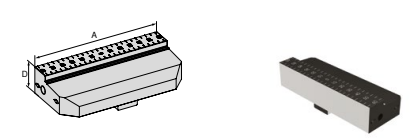

Za širino primeža	A	A ₁	D	D ₁	D ₂	E	M	M ₁	M ₂	EUR	Y4	NCG	H5G / -S / -Z	X5G-Z / -S	ESG 4	ESG 5	HDG 2	ZSG 4	ZSG mini	DSG 4	Veriso	HSG		
125	125		27							324,00	80 908 31400			●										

Stopničasta čeljust, prijemalo s karbidno trdino 5 mm

▲ Cena za kos

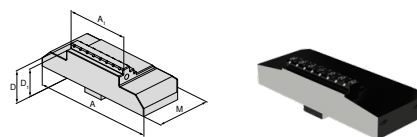

Za širino primeža	A	A ₁	D	D ₁	D ₂	E	M	M ₁	M ₂	EUR	Y4	NCG	H5G / -S / -Z	X5G-Z / -S	ESG 4	ESG 5	HDG 2	ZSG 4	ZSG mini	DSG 4	Veriso	HSG		
125	125	40	27	22			57			358,00	80 908 31100			●										
125	125	65	27	22			57			370,00	80 908 31000			●										
125	125	80	27	22			57			380,00	80 908 30900			●										
125	125	125	27	22			57			392,00	80 908 30800			●										

Pregled sistemov čeljusti

Čeljusti v mehki izvedbi, jeklo

- ▲ Material: 16MnCr5
- ▲ Cena za kos

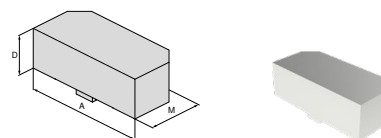

Za širino primeža	A	A ₁	D	D ₁	D ₂	E	M	M ₁	M ₂
125	125		33				57		

EUR

Y4

140,00

80 909 31200

NCG	H5G / -S / -Z	X5G-Z / -S	ESG 4	ESG 5	HDG 2	ZSG 4	ZSG mini	DSG 4	Verso	HSG
		●								

Reliefni profil obrnljive čeljusti

- ▲ Cena za kos
- ▲ Primerna za LANG-ov predodtisnjeni reliefni profil

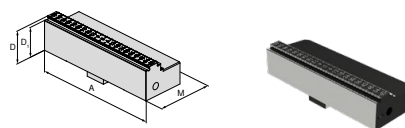

Za širino primeža	A	A ₁	D	D ₁	D ₂	E	M	M ₁	M ₂
125	125		27	24			57		

EUR

Y4

324,00

80 908 31200

NCG	H5G / -S / -Z	X5G-Z / -S	ESG 4	ESG 5	HDG 2	ZSG 4	ZSG mini	DSG 4	Verso	HSG
		●								

Adapterska plošča

- ▲ za vpenjanje 6-delnih obrnljivih čeljusti
- ▲ Cena za kos
- ▲ vklj. s pokravnimi vijaki

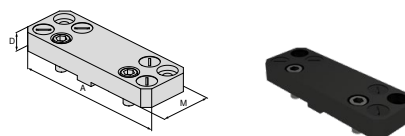

Za širino primeža	A	A ₁	D	D ₁	D ₂	E	M	M ₁	M ₂
125	180		22				104		

EUR

Y4

414,00

80 909 31500

NCG	H5G / -S / -Z	X5G-Z / -S	ESG 4	ESG 5	HDG 2	ZSG 4	ZSG mini	DSG 4	Verso	HSG
		●								

Vrtljiva čeljust

- ▲ za vpenjanje 6-delnih obrnljivih čeljusti
- ▲ Cena za kos
- ▲ vklj. s pokravnimi vijaki

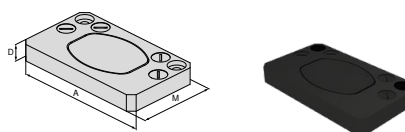

Za širino primeža	A	A ₁	D	D ₁	D ₂	E	M	M ₁	M ₂
125	180		22				62		

EUR

Y4

553,00

80 909 31300

NCG	H5G / -S / -Z	X5G-Z / -S	ESG 4	ESG 5	HDG 2	ZSG 4	ZSG mini	DSG 4	Verso	HSG
		●								

Pregled sistemov čeljusti

6-delni čeljustni nastavek, s prijemalom iz karbidne trdine

- ▲ 1 = gladka
- ▲ 2 = karbidno prijemalo
- ▲ 3 = karbidno prijemalo s stopnico 3 mm
- ▲ 4 = karbidno prijemalo s stopnico 8 mm
- ▲ 5 = karbidno prijemalo, okroglo, s stopnico 8 mm
- ▲ 6 = karbidno prijemalo, okroglo
- ▲ vklj. s pritrdilnimi vijaki

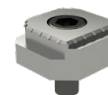
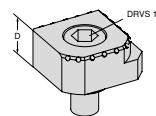

Za širino primeža	A	A ₁	D	D ₁	D ₂	E	M	M ₁	M ₂	EUR	Y4	NCG	H5G / -S / -Z	X5G-Z / -S	ESG 4	ESG 5	HDG 2	ZSG 4	ZSG mini	DSG 4	Verso	HSG	
			18							117,00	80 890 35300	●	●	●	●				●	●	●	●	

Precizna čeljust

- ▲ Cena za komplet

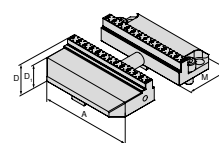

Za širino primeža	A	A ₁	D	D ₁	D ₂	E	M	M ₁	M ₂	EUR	Y4	NCG	H5G / -S / -Z	X5G-Z / -S	ESG 4	ESG 5	HDG 2	ZSG 4	ZSG mini	DSG 4	Verso	HSG	
125	125		27	24			57			490,00	80 908 31300			●									

Postopek za komplet kaljenih preciznih čeljusti

X5G-Z navdušuje s svojo izjemno natančnostjo. Vse komponente so brušene ali rezkane v kaljeno, do visoke natančnosti. Kljub temu še vedno obstajajo aplikacije, pri katerih zahteve po natančnosti ni mogoče v celoti izpolniti zaradi tolerančnih ujemov čeljusti z gibljivim oprijemom. Za te situacije nudimo natančni kaljeni komplet čeljusti (št. artikla **80 908 31300**), ki ga lahko stranka rezka v kaljeno, na vpenjalni plošči (obe strani).

Rezkanje v kaljeno se izvaja v natančnem primežu (oba vijaka na podpornih čeljustih zategnjena na 140 Nm). Natančne čeljusti morajo biti rezkane v skladu z prikazani pogledi (1+2). Priložena referenčna kladica se uporablja za vpenjanje v standardnem položaju (1). Za vpenjanje v položaju VS (2) lahko uporabite merilno kladico.

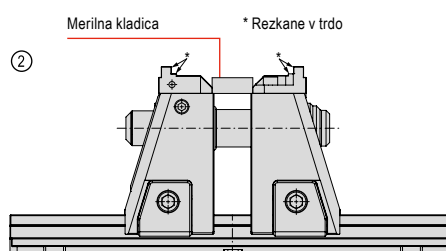
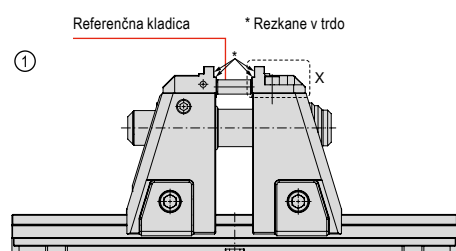

Pregled pribora za sisteme

Vreteno za 5-osni primež X5G-Z

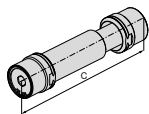

C mm	WT kg
227,5	2,5

80 908 ...

EUR
Y4
392,00 50100

Pogonska ročica

- ▲ Šesteroroba izvedba
- ▲ za hitro nastavitev

H5G-Z
X5G-Z**80 907 ...**

EUR
Y4
81,00 500

Podaljšek potezne palice

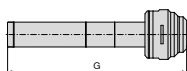

Za širino mm	DRVS mm
125	14

80 908 ...

EUR
Y4
164,00 80000
177,00 80100
205,00 80200
235,00 80300

Za širino mm	G mm
125	430
125	500
125	630
125	800

Natični nastavek

**80 877 ...**

EUR
Y4
18,20 214

Štirirobi	DRVS mm
1/2"	14

Momentni ključ

- ▲ brez natičnega nastavka

**80 884 ...**

EUR
Y4
280,00 502

Štirirobi	TQX Nm
1/2"	10 - 100

ESG 4

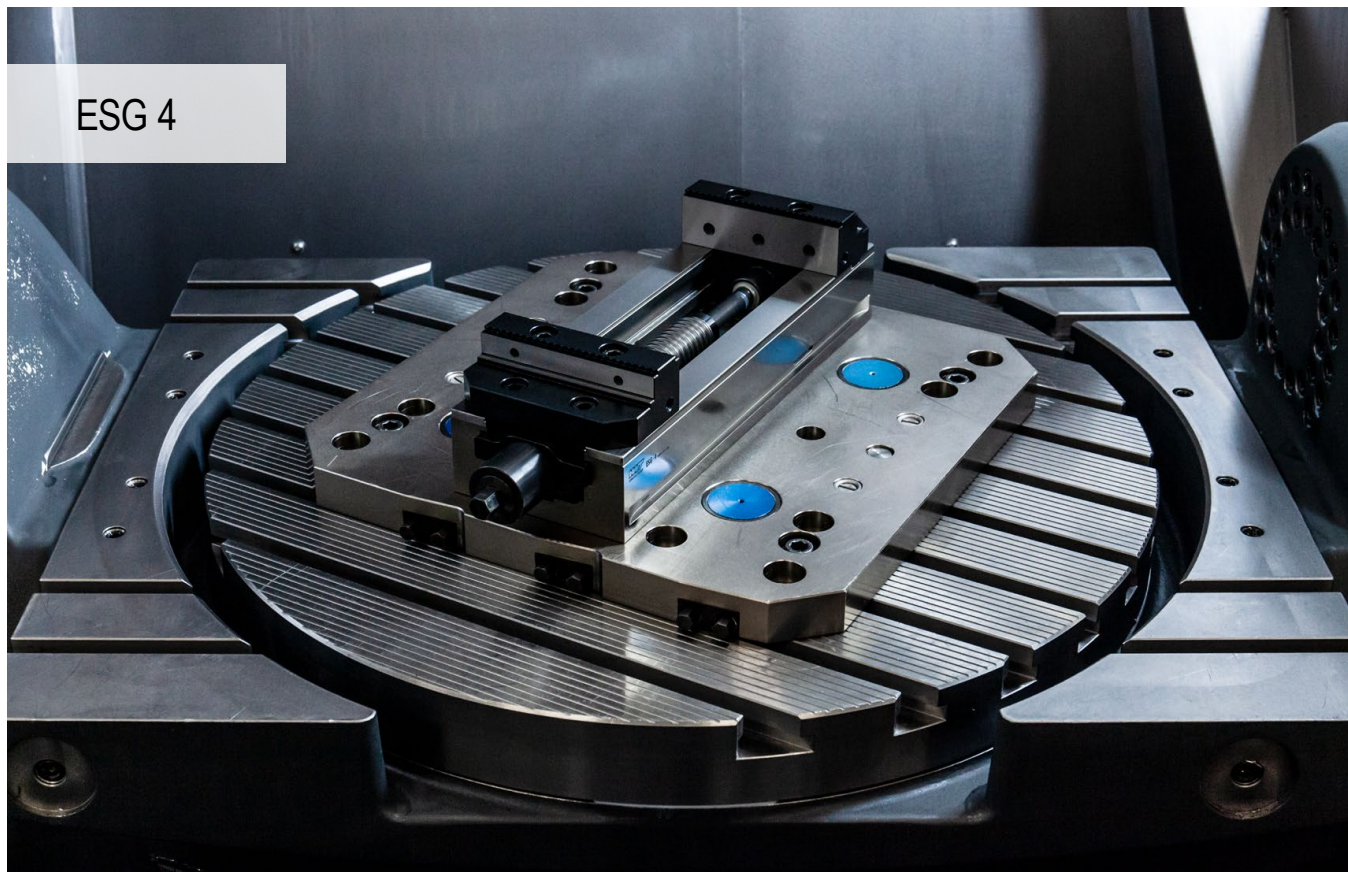

Visoko učinkovit univerzalni primež za obdelavo surovcev in polizdelkov

Enojni primež ESG 4 prepričuje s hitrim vpenjanjem, hitro nastavitvijo območja vpenjanja, nizko konstrukcijo in majhno težo.

Prednosti za vas:

- ▲ Več odtokov za hladilno mazalno sredstvo za nemoteno delo in nadzorovano odvajanje
- ▲ Preprosto in hitro pozicioniranje na vpenjalnem sistemu z ničelno točko MNG
- ▲ Velike vpenjalne sile od 5 do 50 kN z nizkim zateznim momentom
- ▲ Preprosta in hitra menjava čeljusti z 4 vijaki
- ▲ Preprosta in hitra odstranitev celotne vretenske enote
- ▲ Obsežen program modularnih čeljusti

Vpenjanje/usmerjanje:



ESG 4 – 80 mm = pritrditve z vijaki M8 skozi osnovno telo
ESG 4 – 125 mm/160 mm = pritrditve z vijaki M12 in vijaki za namestitve skozi osnovno telo



Pritrditev s 4 vpenjalnimi sponami
Kataloška št. 80 890 315



Pritrditev z vpenjalnim sistemom z ničelno točko
ESG 4 – 80 mm = 1 vpenjalni čep in varovanje pred zasukom
ESG 4 – 125/160 mm = 2 vpenjalna čepa, medosna mera 200 mm

Vpenjalna sila:

Zatezni moment / vpenjalna sila ESG 4 – 80 mm

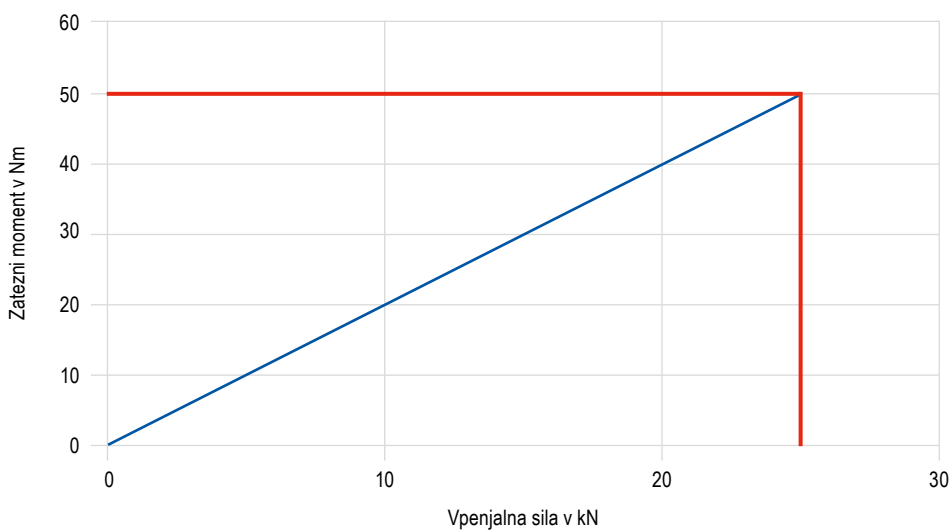

Zatezni moment / vpenjalna sila ESG 4 – 125 mm

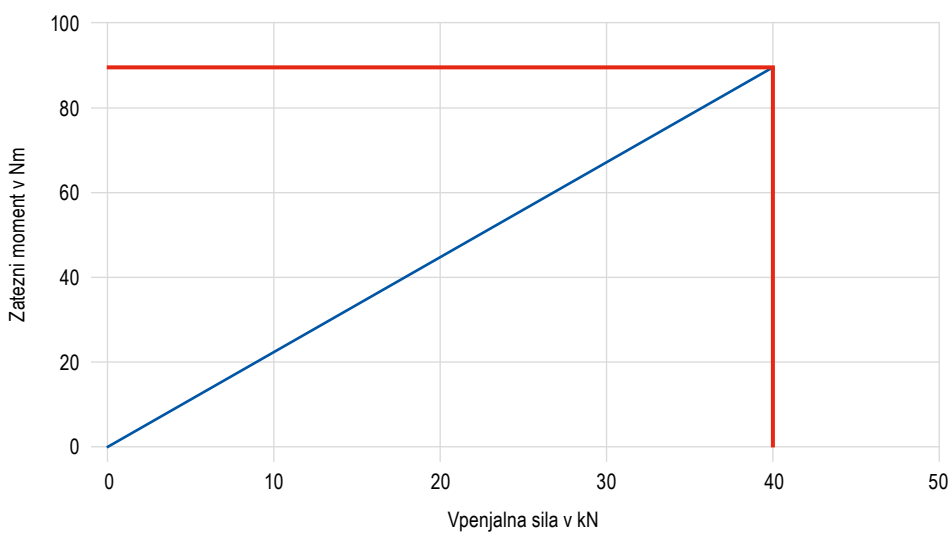

Zatezni moment / vpenjalna sila ESG 4 – 160 mm

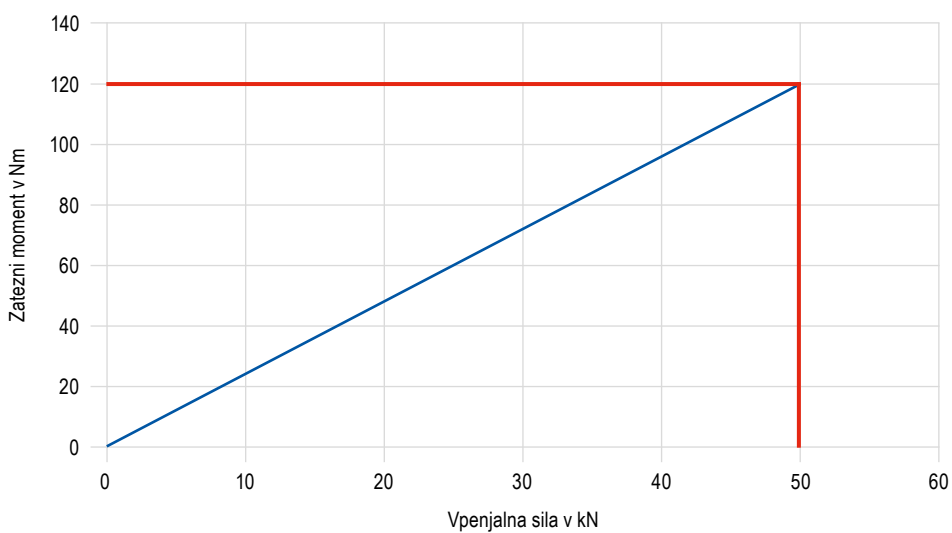

SoloClamp – ESG 4

- ▲ Preprosti primež brez sistemskih čeljusti
- ▲ Hitro 160-stopinjsko vpenjanje z moment ključem
- ▲ Hitrejša namestitvev in odstranitev vretenske enote
- ▲ $\pm 0,01$ mm natančnost ponovitve, ($\pm 0,015$ mm pri širini čeljusti A = 160 mm)

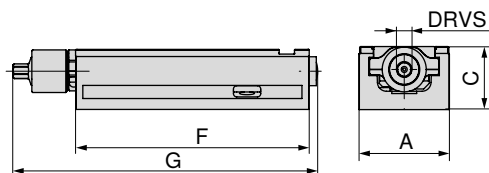
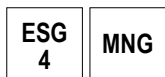

A	C ^{-0.02}	F	G	DRVS	MXC	WT	Območje vpenjanja	80 901 ...
mm	mm	mm	mm	mm	kN	kg	mm	EUR
80	55	214	284	12	25	5,0	0-192	Y4 1.230,00
125	60	362	433	14	40	15,0	0-308	080 1.520,00
160	70	480	559	14	50	28,5	0-434	125 2.220,00
								160

Vodnik po primežih

Mere spodnje strani	52	Preglednice z merami za različne čeljusti	53+54
Pribor za sisteme	55–58	Vpenjalni sistem z ničelno točko MNG/PNG	134–163
Splošni pribor	164–183		

Mere spodnje strani MSG 4

Širina osnovnega telesa 80 mm
in dolžina 214 mm

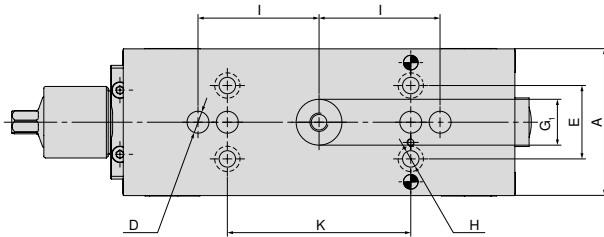

A	D	E	G ₁	H	I	K
mm	mm	mm	mm	mm	mm	mm
80	12	40	25	9	66	100

Širina osnovnega telesa 125 mm
in dolžina 362 mm

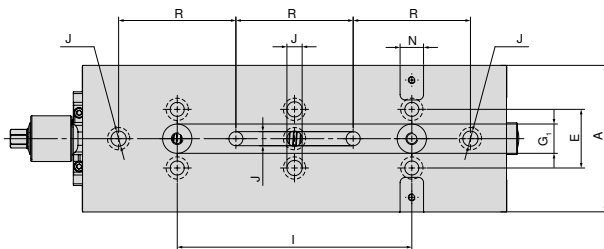

A	E	G ₁	I	J	N _{H7}	R
mm	mm	mm	mm	mm	mm	mm
125	50	25	200	13	20	100

Širina osnovnega telesa 160 mm
in dolžina 480 mm

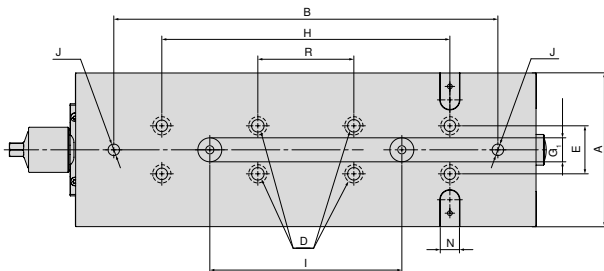

A	B	D	E	G ₁	H	I	J	N _{H7}	R
mm	mm	mm	mm	mm	mm	mm	mm	mm	mm
160	400	13	50	25	300	200	12	20	100

Preglednica z merami ESG 4 za različne čeljusti

Z blok čeljustmi

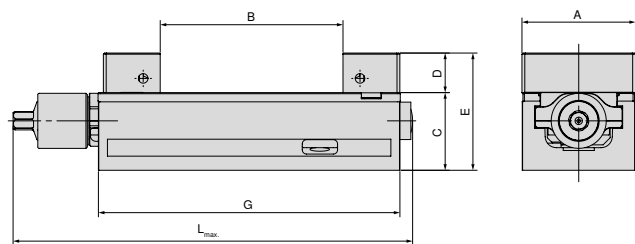

A mm	B mm	C mm	D mm	E mm	G mm	L _{max.} mm	Kataloška št. Sistemske čeljusti		
80	0 - 130	55	28	83	214	308	80 901 31200	+	80 901 31300
125	0 - 231	60	40	100	362	432	80 901 31400	+	80 901 31500
160	0 - 312	70	50	120	480	559	80 901 31600	+	80 901 31700

Z aluminijastimi čeljustmi v mehki izvedbi

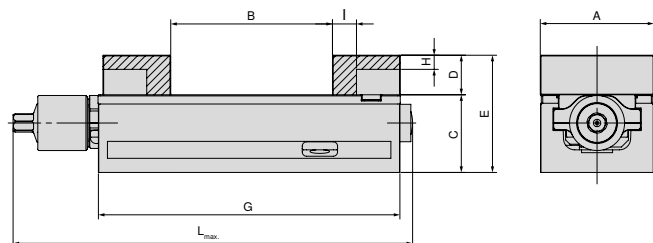

A mm	B mm	C mm	D mm	E mm	G mm	H mm	I mm	L _{max.} mm	Kataloška št. Sistemske čeljusti	
80	0 - 115	55	28	83	214	10	17	284	80 901 307	+ 80 878 850
125	0 - 219	60	40	100	362	23	27	432	80 901 304	+ 80 878 550
160	0 - 309	70	50	120	480	23	30	559	80 901 301	+ 80 878 305

Z vrtljivo in adaptersko ploščo

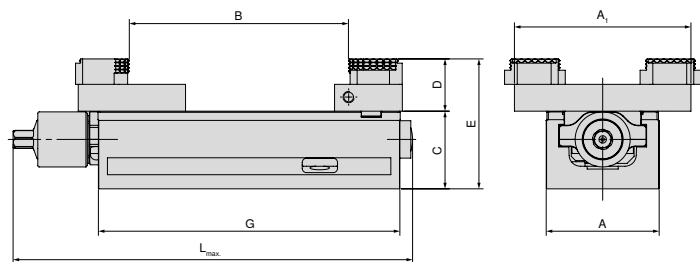

A mm	A ₁ mm	B mm	C mm	D mm	E mm	G mm	L _{max.} mm	Kataloška št. Sistemske čeljusti		
80	125	5 - 155	55	19	92	214	284	80 878 870	+	80 901 501
125	180	4 - 306	60	22	100	362	432	80 878 570	+	80 901 502
160	256	11 - 463	70	22	110	480	559	80 878 670	+	80 901 503

Preglednica z merami ESG 4 za različne čeljusti

Z obrnljivimi čeljustmi, stopnja 3 mm

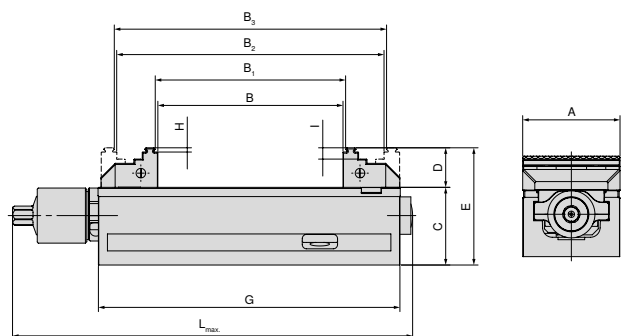

A mm	B mm	B ₁ mm	B ₂ mm	B ₃ mm	C mm	D mm	E mm	G mm	H mm	I mm	L _{max} mm	Kataloška št. Sistemske čeljusti		
80	0 - 130	4 - 134	59 - 188	63 - 192	55	28	83	214	3	8	284	80 901 306	+	80 878 810
125	0 - 231	8 - 238	71 - 301	78 - 308	60	40	100	362	3	18	433	80 901 302	+	80 901 303
160	0 - 310	8 - 317	117 - 427	125 - 434	70	50	120	480	3	10	559	80 901 300	+	80 878 610

Z obrnljivimi prijemalnimi čeljustmi, 3 mm, širina 40 mm

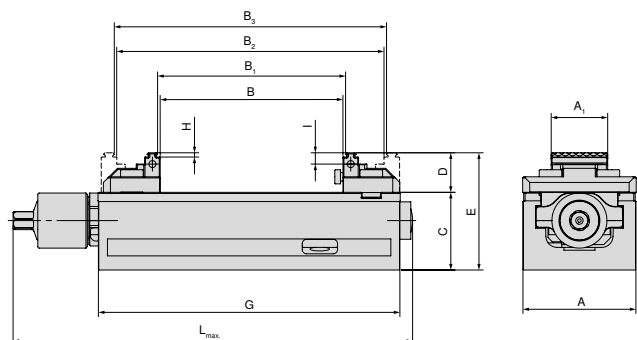

A mm	A ₁ mm	B mm	B ₁ mm	B ₂ mm	B ₃ mm	C mm	D mm	E mm	G mm	H mm	I mm	L _{max} mm	Kataloška št. Sistemske čeljusti		
80	40	0 - 130	4 - 134	59 - 188	63 - 192	55	28	83	214	3	8	284	80 901 308	+	80 878 81900

Z obrnljivimi prijemalnimi čeljustmi, stopnja 3 mm, širina 65 mm

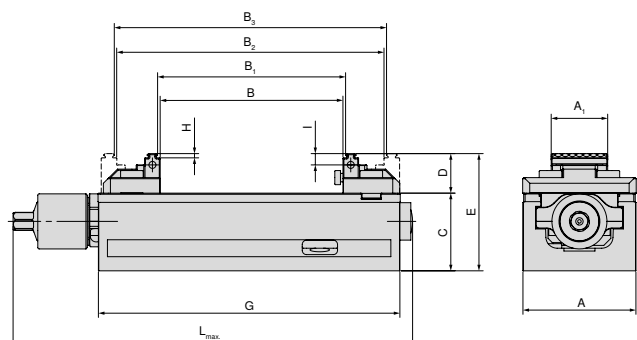

A mm	A ₁ mm	B mm	B ₁ mm	B ₂ mm	B ₃ mm	C mm	D mm	E mm	G mm	H mm	I mm	L _{max} mm	Kataloška št. Sistemske čeljusti		
125	65	0 - 240	8 - 247	77 - 317	84 - 324	60	33	93	362	3	9	432	80 901 305	+	80 878 51900

Pregled sistemov čeljusti

Obrnljiva čeljust, prijemalna, stopnja 3 mm, fiksna

▲ Cena za kos

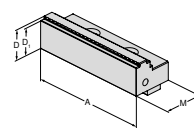

Za širino primeža	A	A ₁	D	D ₁	D ₂	E	M	M ₁	M ₂	EUR	Y4	NCG	H5G / -S / -Z	X5G-Z / -S	ESG 4	ESG 5	HDG 2	ZSG 4	ZSG mini	DSG 4	Verso	HSG	
80	80		28	25			40			163,00	80 901 306				●	●							
125	125		40	37			66			224,00	80 901 302				●	●					●		
160	160		50	47			81			404,00	80 901 300				●	●							

Obrnljiva čeljust, prijemalna, stopnja 3 mm, pomična

▲ Cena za kos

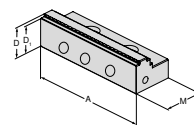

Za širino primeža	A	A ₁	D	D ₁	D ₂	E	M	M ₁	M ₂	EUR	Y4	NCG	H5G / -S / -Z	X5G-Z / -S	ESG 4	ESG 5	HDG 2	ZSG 4	ZSG mini	DSG 4	Verso	HSG	
80	80		28	25			40			135,00	80 878 810				●	●			●		●		
125	125		40	37			66			224,00	80 901 303				●	●				●		●	
160	160		50	47			81			404,00	80 878 610				●	●			●		●		

Bločna čeljust, fiksna

▲ Cena za kos

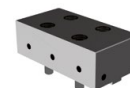
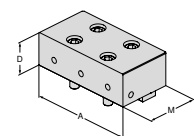

Za širino primeža	A	A ₁	D	D ₁	D ₂	E	M	M ₁	M ₂	EUR	Y4	NCG	H5G / -S / -Z	X5G-Z / -S	ESG 4	ESG 5	HDG 2	ZSG 4	ZSG mini	DSG 4	Verso	HSG	
80	80		28				40			251,00	80 901 31200				●	●							
125	125		40				66			349,00	80 901 31400				●	●							
160	160		50				81			441,00	80 901 31600				●	●							

Bločna čeljust, pomična

▲ Cena za kos

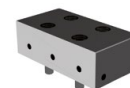
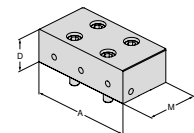

Za širino primeža	A	A ₁	D	D ₁	D ₂	E	M	M ₁	M ₂	EUR	Y4	NCG	H5G / -S / -Z	X5G-Z / -S	ESG 4	ESG 5	HDG 2	ZSG 4	ZSG mini	DSG 4	Verso	HSG	
80	80		28				40			244,00	80 901 31300				●	●			●		●		
125	125		40				66			342,00	80 901 31500				●	●				●		●	
160	160		50				81			430,00	80 901 31700				●	●			●		●		

Pregled sistemov čeljusti

Aluminijasta čeljust, fiksna

- ▲ Za proizvodnjo oblikovnih čeljusti
- ▲ Cena za kos

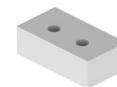
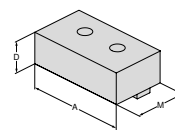

Za širino primeža	A	A ₁	D	D ₁	D ₂	E	M	M ₁	M ₂	EUR	Y4	NCG	H5G / -S / -Z	X5G-Z / -S	ESG 4	ESG 5	HDC 2	ZSG 4	ZSG mini	DSG 4	Verso	HSG		
80	80		28				48			101,00	80 901 307				●	●								
125	125		40				68			110,00	80 901 304				●	●								
160	160		50				85			124,00	80 901 301				●	●								

Aluminijasta čeljust, pomična

- ▲ Za proizvodnjo oblikovnih čeljusti
- ▲ Cena za kos

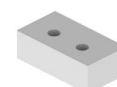
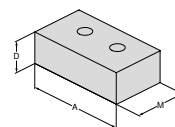

Za širino primeža	A	A ₁	D	D ₁	D ₂	E	M	M ₁	M ₂	EUR	Y4	NCG	H5G / -S / -Z	X5G-Z / -S	ESG 4	ESG 5	HDC 2	ZSG 4	ZSG mini	DSG 4	Verso	HSG		
80	80		28				48			86,40	80 878 850				●	●		●						
125	125		40				68			98,30	80 878 550				●	●				●				
160	160		50				85			124,00	80 878 305				●	●		●						

Mehka čeljust, jeklo, fiksna

- ▲ Material: 16MnCr5
- ▲ Za proizvodnjo oblikovnih čeljusti
- ▲ Cena za kos

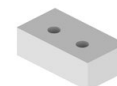
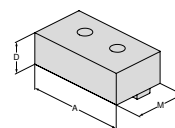

Za širino primeža	A	A ₁	D	D ₁	D ₂	E	M	M ₁	M ₂	EUR	Y4	NCG	H5G / -S / -Z	X5G-Z / -S	ESG 4	ESG 5	HDC 2	ZSG 4	ZSG mini	DSG 4	Verso	HSG		
80	80		28				48			104,00	80 901 31800				●	●								
125	125		40				68			125,00	80 901 31900				●	●								

Čeljust v mehki izvedbi, jeklo, pomična

- ▲ Material: 16MnCr5
- ▲ Za proizvodnjo oblikovnih čeljusti
- ▲ Cena za kos

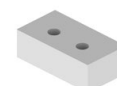
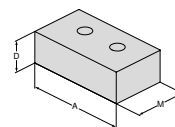

Za širino primeža	A	A ₁	D	D ₁	D ₂	E	M	M ₁	M ₂	EUR	Y4	NCG	H5G / -S / -Z	X5G-Z / -S	ESG 4	ESG 5	HDC 2	ZSG 4	ZSG mini	DSG 4	Verso	HSG		
80	80		28				48			89,10	80 878 32000				●	●		●						
125	125		40				68			112,00	80 878 32100				●	●		●						

Pregled sistemov čeljusti

Obrnljiva čeljust, prijemalna, širina 40 mm, fiksna

- ▲ Cena za kos
- ▲ Obojstranska prijemalna stopnica

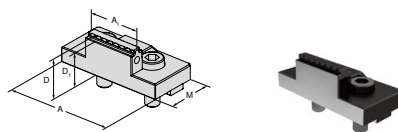

Za širino primeža	A	A ₁	D	D ₁	D ₂	E	M	M ₁	M ₂	EUR	Y4	NCG	H5G / -S / -Z	X5G-Z / -S	ESG 4	ESG 5	HDG 2	ZSG 4	ZSG mini	DSG 4	Verso	HSG	
80	80	40	28	25			40			196,00	80 901 308				●								

Obrnljiva čeljust, prijemalna, stopnja 3 mm, širina 40 mm, pomična

- ▲ Cena za kos

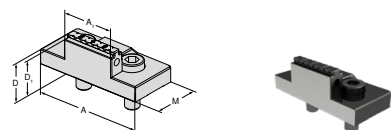

Za širino primeža	A	A ₁	D	D ₁	D ₂	E	M	M ₁	M ₂	EUR	Y4	NCG	H5G / -S / -Z	X5G-Z / -S	ESG 4	ESG 5	HDG 2	ZSG 4	ZSG mini	DSG 4	Verso	HSG	
80	80	40	28	25			40			180,00	80 878 81900				●			●					

5-osna obrnljiva čeljust, prijemalna, stopnja 3 mm, širina 65 mm, nepomična

- ▲ Cena za kos
- ▲ Obojstranska prijemalna stopnica

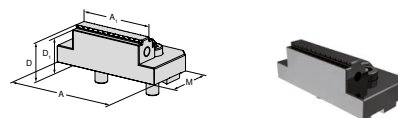

Za širino primeža	A	A ₁	D	D ₁	D ₂	E	M	M ₁	M ₂	EUR	Y4	NCG	H5G / -S / -Z	X5G-Z / -S	ESG 4	ESG 5	HDG 2	ZSG 4	ZSG mini	DSG 4	Verso	HSG	
125	95	65	33	30			57			214,00	80 901 305				●								

5-osna obrnljiva čeljust, prijemalna, stopnja 3 mm, širina 65 mm, pomična

- ▲ Obojstranska prijemalna stopnica
- ▲ Cena za kos

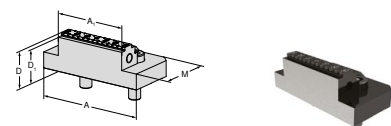

Za širino primeža	A	A ₁	D	D ₁	D ₂	E	M	M ₁	M ₂	EUR	Y4	NCG	H5G / -S / -Z	X5G-Z / -S	ESG 4	ESG 5	HDG 2	ZSG 4	ZSG mini	DSG 4	Verso	HSG	
125	95	65	33	30			57			196,00	80 878 51900							●					

Pregled sistemov čeljusti

Vrtljiva čeljust, pomična

- ▲ Za vpenjanje 6-delnih obrnljivih čeljusti
- ▲ Cena za kos

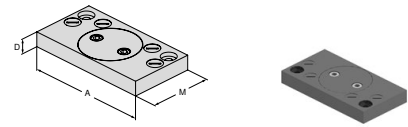

Za širino primeža	A	A ₁	D	D ₁	D ₂	E	M	M ₁	M ₂	EUR	Y4	NCG	H5G / -S / -Z	X5G-Z / -S	ESG 4	ESG 5	HDG 2	ZSG 4	ZSG mini	DSG 4	Verso	HSG	
80	125		19				76			409,00	80 878 870				●				●		●		
125	180		22				95			426,00	80 878 570				●				●		●		
160	256		22				170			726,00	80 878 670				●				●		●		

Adapterska čeljust

- ▲ Za vpenjanje 6-delnih obrnljivih čeljusti
- ▲ Cena za kos

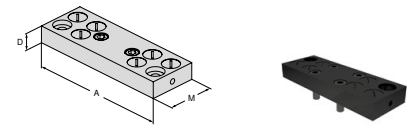

Za širino primeža	A	A ₁	D	D ₁	D ₂	E	M	M ₁	M ₂	EUR	Y4	NCG	H5G / -S / -Z	X5G-Z / -S	ESG 4	ESG 5	HDG 2	ZSG 4	ZSG mini	DSG 4	Verso	HSG	
80	125		19				48			291,00	80 901 501				●								
125	180		22				62			346,00	80 901 502				●								
160	256		22				125			484,00	80 901 503				●								

6-delni čeljustni nastavek

- ▲ 1 = Gladka, prevlečena z volframovim karbidom
- ▲ 2 = Prijemalo s stopnico 3 mm
- ▲ 3 = Prijemalo s stopnico 8 mm
- ▲ 4 = Prijemalo s stopnico 18 mm
- ▲ 5 = Prijemalo, okroglo, s stopnico 8 mm
- ▲ 6 = Prijemalo, okroglo
- ▲ M_{najv.} = 60 Nm
- ▲ Vklj. s pritrdilnimi vijaki

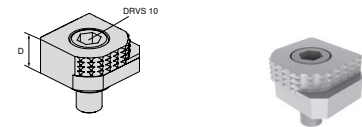

Za širino primeža	A	A ₁	D	D ₁	D ₂	E	M	M ₁	M ₂	EUR	Y4	NCG	H5G / -S / -Z	X5G-Z / -S	ESG 4	ESG 5	HDG 2	ZSG 4	ZSG mini	DSG 4	Verso	HSG	
			18							80,60	80 892 246	●	●	●	●				●		●	●	

6-delni čeljustni nastavek, s prijemalom iz karbidne trdine

- ▲ 1 = gladka
- ▲ 2 = karbidno prijemalo
- ▲ 3 = karbidno prijemalo s stopnico 3 mm
- ▲ 4 = karbidno prijemalo s stopnico 8 mm
- ▲ 5 = karbidno prijemalo, okroglo, s stopnico 8 mm
- ▲ 6 = karbidno prijemalo, okroglo
- ▲ vklj. s pritrdilnimi vijaki

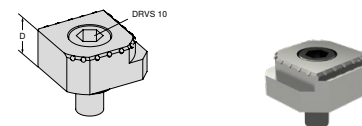

Za širino primeža	A	A ₁	D	D ₁	D ₂	E	M	M ₁	M ₂	EUR	Y4	NCG	H5G / -S / -Z	X5G-Z / -S	ESG 4	ESG 5	HDG 2	ZSG 4	ZSG mini	DSG 4	Verso	HSG	
			18							117,00	80 890 35300	●	●	●	●				●		●	●	

ESG 5

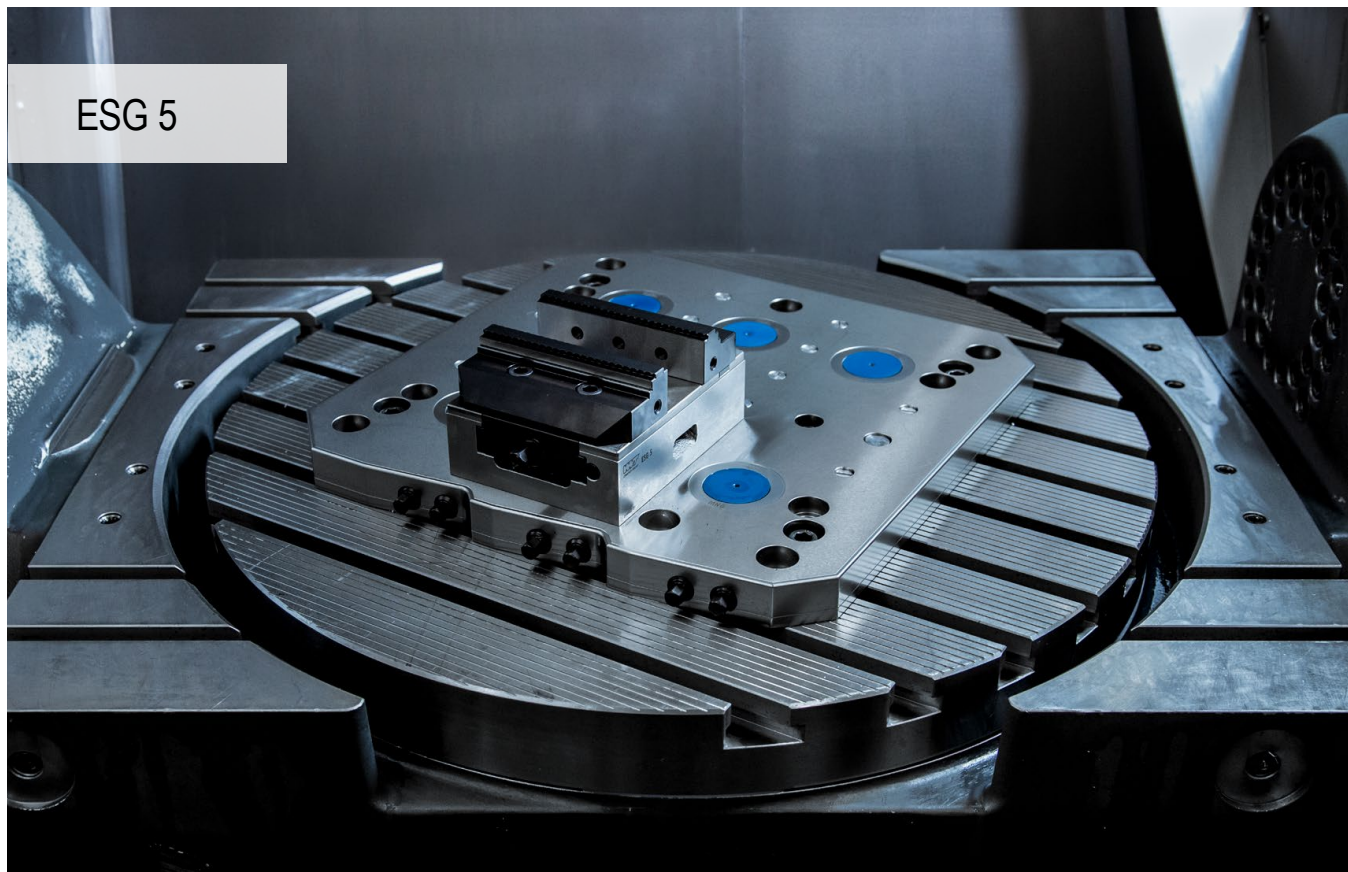

Optimiziran primež ESG 5 – največja natančnost in procesna varnost

Nov centrični primež ESG 5 je podedoval vse priljubljene lastnosti svojega predhodnika ter dvignil standard glede prijaznosti do uporabnika in vzdržljivosti. Pri posodobitvi primeža preproste izvedbe sta bila na prvem mestu optimizirana uporaba in dolga življenjska doba.

Prednosti za vas:

- ▲ Posebej zasnovan za obdelavo z druge strani z visoko kotno natančnostjo
- ▲ Kompaktna oblika z idealno dostopnostjo
- ▲ Menjava čeljusti je hitra in enostavna z samo dvema vijakoma
- ▲ Enaka vpenjalna območja, znatno izboljšana interferenčna kontura, obsežen modularni obseg čeljusti
- ▲ Trajnostni model z ponikljanim osnovnim ohišjem zagotavlja dolgo življenjsko dobo

Vpenjanje/usmerjanje:



Pritrditev z vpenjalnim sistemom z ničelno točko
ESG 5 – 80 mm L-130 mm + L-190 mm
ESG 5 – 125 mm L-160 mm + L-235 mm

1 vpenjalni čep + indeksirni čep MNG



Pritrditev z vpenjalnim sistemom z ničelno točko
ESG 5 – 125 mm + L-300 mm
ESG 5 – 160 mm + L-280 mm + L-480 mm

2 vpenjalna čepa



Vse različice so opremljene s preciznimi izvrtinami $\text{Ø } 12^{+0,05}$, ki omogočajo natančno pozicioniranje ESG 5. Vse različice je mogoče pritrditi od zgoraj z vijaki skozi osnovno telo.

Vpenjanje/usmerjanje:



ESG 5 – 125 mm L-235 mm + L-300 mm
ESG 5 – 160 mm L-280 mm + L-480 mm

Te 4 različice je mogoče alternativno vpeti tudi z vpenjalnimi sponami.

Vpenjalna sila:

Zatezni moment / vpenjalna sila ESG 5 – 80 mm

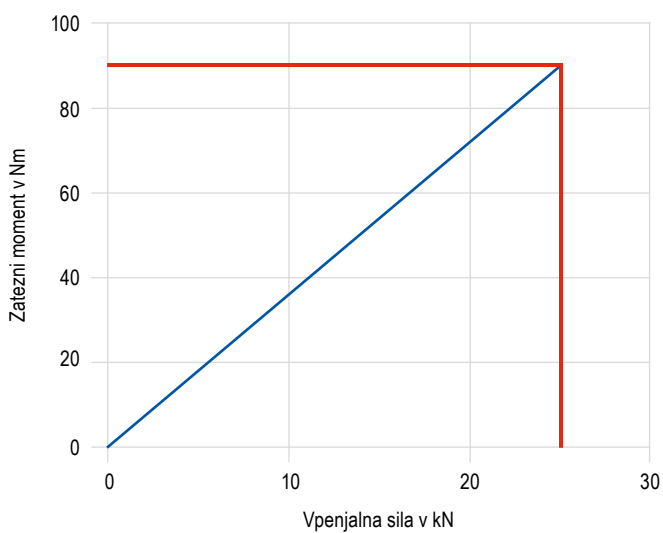

Zatezni moment / vpenjalna sila ESG 5 – 125 mm

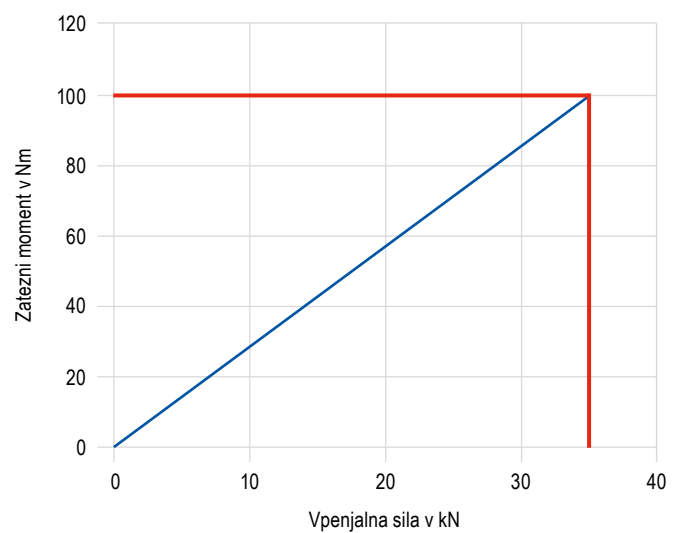

Zatezni moment / vpenjalna sila ESG 5 – 160 mm

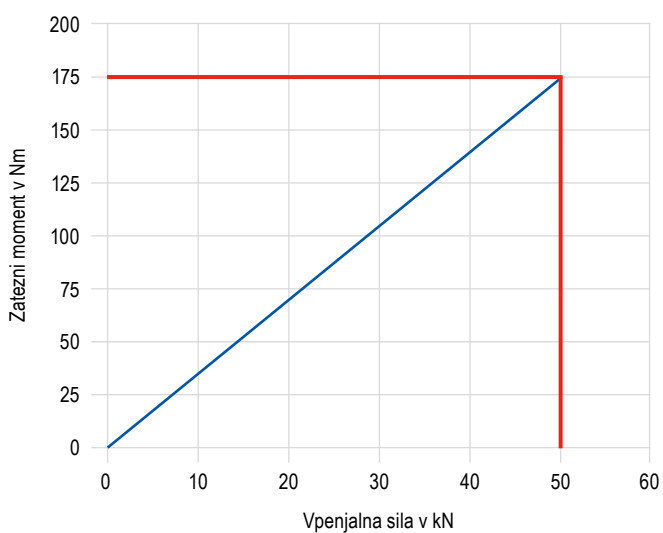

SoloClamp – ESG 5

- ▲ Preprosti primež brez sistemskih čeljusti
- ▲ Posebej zasnovan za obdelavo z druge strani z visoko kotno natančnostjo
- ▲ natančnost ponovitve med postopki vpenjanja $\pm 0,01$ mm
- ▲ primerno za PNG in MNG

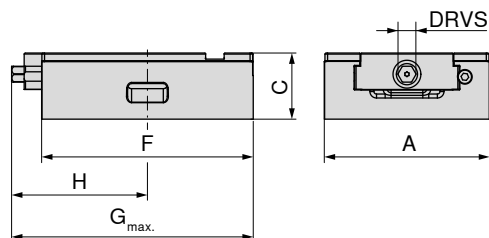
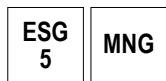

A	C _{±0.01}	F	G _{max.}	H	DRVS	MXC	WT	80 857 ...	
mm	mm	mm	mm	mm	mm	kN	kg	EUR	Y4
80	50	130	155,0	82	12	25	2,9	553,00	08500
80	50	190	203,0	102	12	25	4,4	665,00	08600
125	50	160	169,0	103	12	35	6,0	726,00	15000
125	50	235	235,0	132	12	35	8,4	927,00	15100
125	50	300	300,0	170	12	35	10,5	1.230,00	15200
160	70	280	309,0	169	14	50	25,0	1.710,00	26100
160	70	480	512,5	267	14	50	30,0	2.040,00	26200

Primerno za vpenjalni sistem z ničelno točko				MNG	MNG mini	PNG	LANG Quick Point	LANG Quick Point
Kataloška št.	Tip	Širina v mm	Višina v mm				96 x 96	52 x 52
80 857 08500	ESG 5	80	130	✓	✓	✗	✗	✓
80 857 08600		80	190	✓	✗	✓	✗	✓
80 857 15000		125	160	✓	✗	✓	✓	✓
80 857 15100		125	235	✓	✗	✓	✓	✗
80 857 15200		125	300	✓	✗	✓	✓	✗
80 857 26100		160	280	✓	✗	✓	✓	✗
80 857 26200		160	480	✓	✗	✓	✗	✗

Vodnik po primežih

Mere spodnje strani	63+64	Preglednice z merami za različne čeljusti	65
Pribor za sisteme	66	Vpenjalni sistem z ničelno točko MNG/PNG	134–163
Splošni pribor	164–183		

SoloClamp – ESG 5

- ▲ oklopljen preprosti primež za Erowa ITS 148
- ▲ brez sistemskih čeljusti
- ▲ Posebej zasnovan za obdelavo z druge strani z visoko kotno natančnostjo
- ▲ natančnost ponovitve med postopki vpenjanja $\pm 0,01$ mm

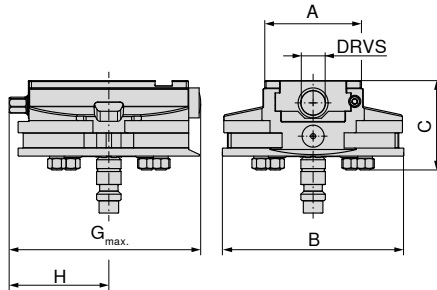
ESG
5

80 857 ...

EUR
Y4

1.370,00 08900

A	B	C	G _{max.}	H	DRVS	MXC	WT
mm	mm	mm	mm	mm	mm	kN	kg
80	148	73	157	81	12	25	5,6

Vodnik po primežih

Mere spodnje strani	63+64	Preglednice z merami za različne čeljusti	65
Pribor za sisteme	66	Vpenjalni sistem z ničelno točko MNG/PNG	134-163
Splošni pribor	164-183		

Mere spodnje strani ESG 5

Širina osnovnega telesa 80 mm
in dolžina 130 mm

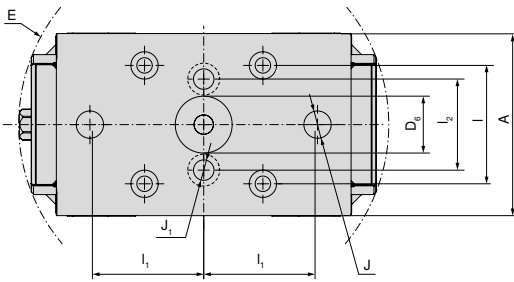

A	D ₆ H ₆	E	I ₁ ±0,015	I ₁ ±0,015	I ₂	J H ₇	J ₁
mm	mm	mm	mm	mm	mm	mm	mm
80	25	163	52	50	40	12	9

Širina osnovnega telesa 80 mm
in dolžina 190 mm

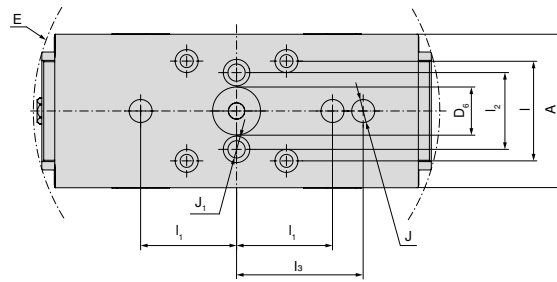

A	D ₆ H ₆	E	I ₁ ±0,015	I ₁ ±0,015	I ₂	I ₃ ±0,015	J H ₇	J ₁
mm	mm	mm	mm	mm	mm	mm	mm	mm
80	25	213	52	50	40	66	12	9

Širina osnovnega telesa 125 mm
in dolžina 160 mm

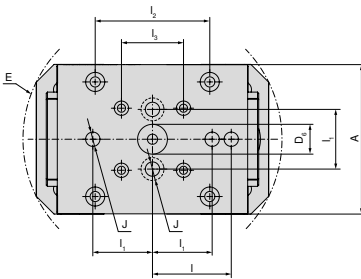

A	D ₆ H ₆	E	I ₁ ±0,015	I ₁ ±0,015	I ₂	I ₃ ±0,015	J H ₇
mm	mm	mm	mm	mm	mm	mm	mm
125	25	218	66	50	96	52	12

Širina osnovnega telesa 125 mm
in dolžina 235 mm

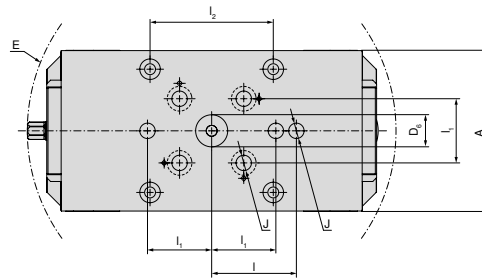

A	D ₆ H ₆	E	I ₁ ±0,015	I ₁ ±0,015	I ₂	J H ₇
mm	mm	mm	mm	mm	mm	mm
125	25	288	66	50	96	12

Širina osnovnega telesa 125 mm
in dolžina 300 mm

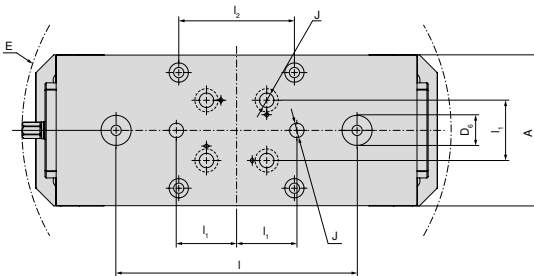

A	D ₆ H ₆	E	I ₁ ±0,015	I ₁ ±0,015	I ₂	J H ₇
mm	mm	mm	mm	mm	mm	mm
125	25	357	200	50	96	12

Mere spodnje strani ESG 5

Širina osnovnega telesa 160 mm
in dolžina 280 mm

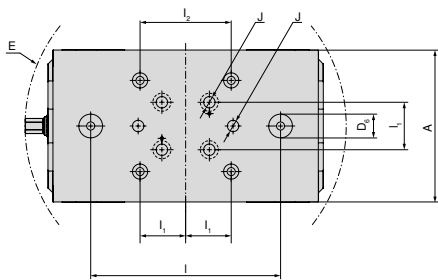

A	D _{6 H6}	E	I _{±0,015}	I _{1 ±0,015}	I ₂	J _{H7}
mm	mm	mm	mm	mm	mm	mm
160	25	339	200	50	96	12

Širina osnovnega telesa 160 mm
in dolžina 480 mm

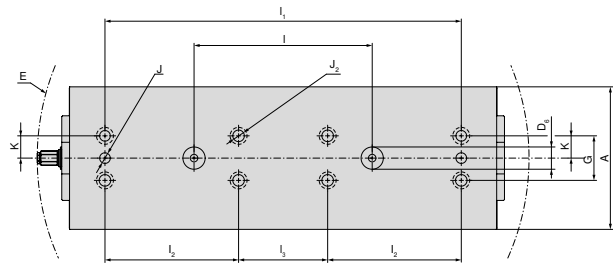

A	D _{6 H6}	E	I _{±0,015}	I _{1 ±0,015}	I ₂	I _{3 ±0,015}	J _{H7}	J _{2 F7}	K _{±0,02}	G
mm	mm	mm	mm	mm	mm	mm	mm	mm	mm	mm
160	25	553	200	400	150	100	12	12	25	50

Preglednica z merami ESG 5 za različne čeljusti

Z obrnljivo čeljustjo, prijemalno, stopnja 3 mm, fiksno in pomično

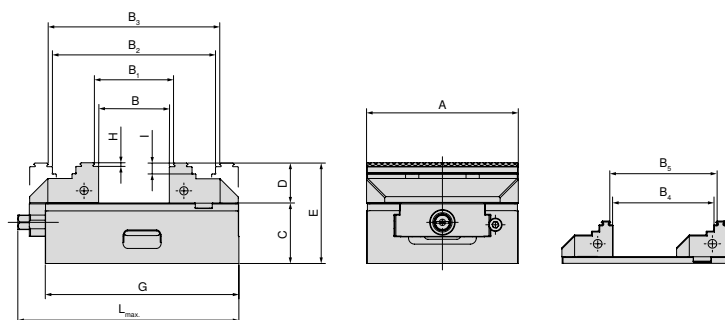

A mm	B mm	B ₁ mm	B ₂ mm	B ₃ mm	B ₄ mm	B ₅ mm	C mm	D mm	E mm	G mm	H mm	I mm	L _{max.} mm	Kataloška št. Sistemske čeljusti
80	0-49	4-53	59-107	63-111	30-78	34-82	50	28	78	130	3	8	155	80 901 306 + 80 878 810
80	0-109	4-113	59-167	63-171	29-134	35-136	50	28	78	190	3	8	206	80 901 306 + 80 878 810
125	0-57	8-64	77-134	84-141	40-95	47-102	50	33	83	160	3	9	183	80 857 30000 + 80 878 510
125	0-127	8-134	77-204	84-211	40-165	47-172	50	33	83	235	3	9	250	80 857 30000 + 80 878 510
125	0-197	8-204	77-274	84-281	40-235	47-242	50	33	83	300	3	9	320	80 857 30000 + 80 878 510
160	0-121	8-128	118-238	125-245	-	-	70	50	120	280	3	10	328	80 901 300 + 80 878 610
160	0-324	8-331	118-441	125-448	-	-	70	50	120	480	3	10	506	80 901 300 + 80 878 610

S 5-osnimi čeljustmi

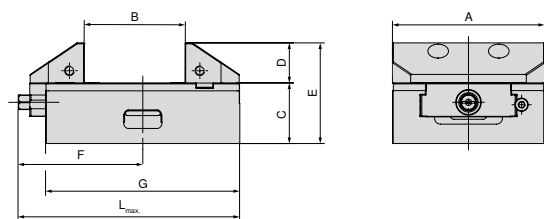

A mm	B mm	C mm	D mm	E mm	F mm	G mm	L _{max.} mm	Kataloška št. Sistemske čeljusti
125	25-82	50	33	83	103	160	183	80 857 30200 + 80 857 30100
125	25-152	50	33	83	132	235	250	80 857 30200 + 80 857 30100
125	25-222	50	33	83	170	300	320	80 857 30200 + 80 857 30100

Pregled sistemov čeljusti

Obrnljiva čeljust, gladka, nepomična

▲ Cena za kos

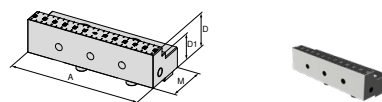

Za širino primeža	A	A ₁	D	D ₁	D ₂	E	M	M ₁	M ₂	EUR	Y4	NCG	H5G / -S / -Z	X5G-Z / -S	ESG 4	ESG 5	HDG 2	ZSG 4	ZSG mini	DSG 4	Verso	HSG	
80	80		28	20			40			195,00						●							
125	125		33	25			57			378,00						●							

Obrnljiva čeljust, gladka, premična

▲ Cena za kos

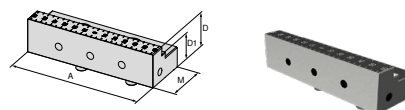

Za širino primeža	A	A ₁	D	D ₁	D ₂	E	M	M ₁	M ₂	EUR	Y4	NCG	H5G / -S / -Z	X5G-Z / -S	ESG 4	ESG 5	HDG 2	ZSG 4	ZSG mini	DSG 4	Verso	HSG	
80	80		28	20			40			195,00						●							
125	125		33	25			57			378,00						●		●					

Obrnljiva čeljust, prijemalna, stopnja 3 mm, fiksna

▲ Cena za kos

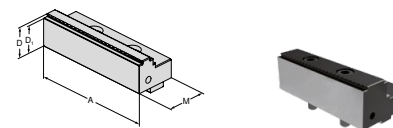

Za širino primeža	A	A ₁	D	D ₁	D ₂	E	M	M ₁	M ₂	EUR	Y4	NCG	H5G / -S / -Z	X5G-Z / -S	ESG 4	ESG 5	HDG 2	ZSG 4	ZSG mini	DSG 4	Verso	HSG	
80	80		28	25			40			163,00					●	●							
125	125		33	30			57			222,00					●	●							
160	160		50	47			81			404,00					●	●							

Obrnljiva čeljust, prijemalna, stopnja 3 mm, pomična

▲ Cena za kos

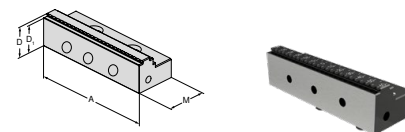

Za širino primeža	A	A ₁	D	D ₁	D ₂	E	M	M ₁	M ₂	EUR	Y4	NCG	H5G / -S / -Z	X5G-Z / -S	ESG 4	ESG 5	HDG 2	ZSG 4	ZSG mini	DSG 4	Verso	HSG	
80	80		28	25			40			135,00					●	●							
125	125		33	30			57			151,00					●	●							
160	160		50	47			81			404,00					●	●							

Pregled sistemov čeljusti

5-osna obrnljiva čeljust, nepomična

▲ Cena za kos

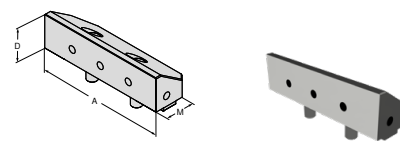

Za širino primeža	A	A ₁	D	D ₁	D ₂	E	M	M ₁	M ₂	EUR	Y4	NCG	H5G / -S / -Z	X5G-Z / -S	ESG 4	ESG 5	HDG 2	ZSG 4	ZSG mini	DSG 4	Verro	HSG		
125	125		33				44,5			224,00						●								
											80 857 30100													

5-osna obrnljiva čeljust, prijemalna, pomična

▲ Cena za kos

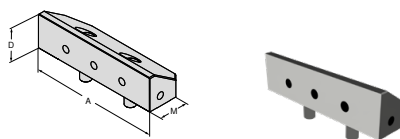

Za širino primeža	A	A ₁	D	D ₁	D ₂	E	M	M ₁	M ₂	EUR	Y4	NCG	H5G / -S / -Z	X5G-Z / -S	ESG 4	ESG 5	HDG 2	ZSG 4	ZSG mini	DSG 4	Verro	HSG		
125	125		33				44,5			224,00						●								
											80 857 30200													

Mehka čeljust, jeklo, fiksna

▲ Material: 16MnCr5

▲ Za proizvodnjo oblikovnih čeljusti

▲ Cena za kos

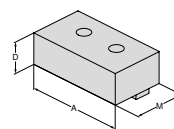

Za širino primeža	A	A ₁	D	D ₁	D ₂	E	M	M ₁	M ₂	EUR	Y4	NCG	H5G / -S / -Z	X5G-Z / -S	ESG 4	ESG 5	HDG 2	ZSG 4	ZSG mini	DSG 4	Verro	HSG		
80	80		28				48			104,00					●	●								
125	125		40				68			125,00					●	●								
											80 901 31800													
											80 901 31900													

Čeljust v mehki izvedbi, jeklo, pomična

▲ Material: 16MnCr5

▲ Za proizvodnjo oblikovnih čeljusti

▲ Cena za kos

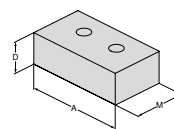

Za širino primeža	A	A ₁	D	D ₁	D ₂	E	M	M ₁	M ₂	EUR	Y4	NCG	H5G / -S / -Z	X5G-Z / -S	ESG 4	ESG 5	HDG 2	ZSG 4	ZSG mini	DSG 4	Verro	HSG	
80	80		28				48			89,10					●	●		●					
125	125		40				68			112,00					●	●		●					
											80 878 32000												
											80 878 32100												

HDG 2

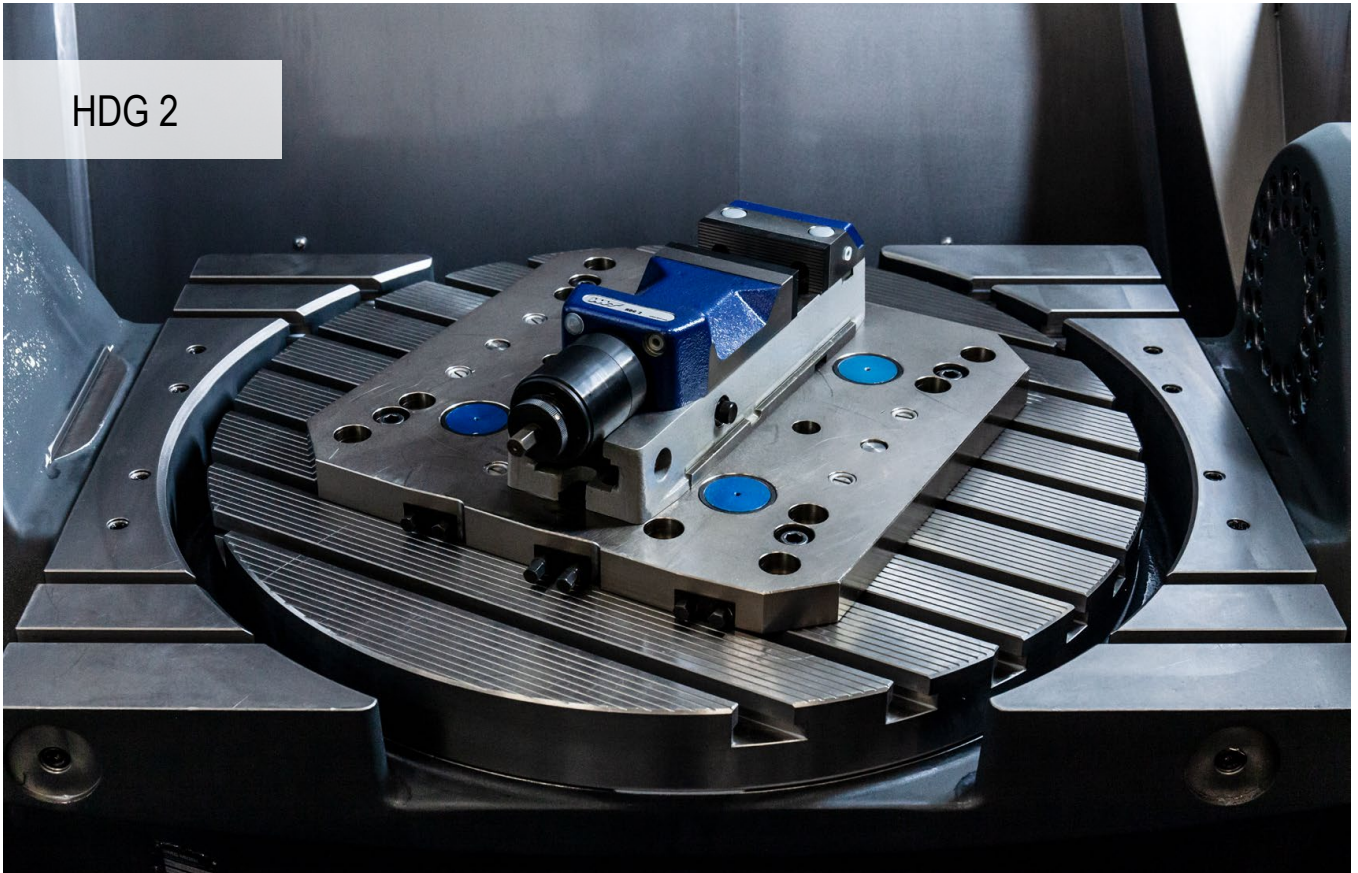

Preverjen visokotlačni vpenjalni sistem

Mehanski strojni primež z brezstopenjsko nastavitvijo vpenjalne sile od 10 do 100 % z samo enim zasukom ročice in vedno enakim končnim položajem ročice. Hitra nastavitvev območja vpenjanja z vtičnimi čepi.

Prednosti za vas:

- ▲ Prihranite čas in moč – samo 1 zasuk ročice
- ▲ Čas vpenjanja < 1 sekundo
- ▲ Preprosta uporaba
- ▲ Brezstopenjska nastavitvev brez uporabe orodja
- ▲ Visoka natančnost obdelave

Vpenjanje/usmerjanje:



Usmerjanje s preciznimi utornimi maticami na utorni mizi z vzdolžnim oziroma prečnim utorom 20^{H7} v osnovnem telesu



Vpenjanje z vijaki skozi osnovno telo ali bočno z vpenjalnimi sponami

SoloClamp – HDG 2

- ▲ Visokotlačni primež
- ▲ Brezstopenjska nastavitev sile
- ▲ Mehanski prenos moči
- ▲ Vpenjalna sila samo z enim obratom ročice
- ▲ Pomične čeljusti, predhodno obdelane za vpetje čeljusti za povečanje območja vpenjanja

Obseg dobave:

Visokotlačni primež, vklj. s 4 vpenjalnimi sponami, pogonsko ročico, 2 profiliranima in kaljenima predložnima čeljustma

**HDG
2**

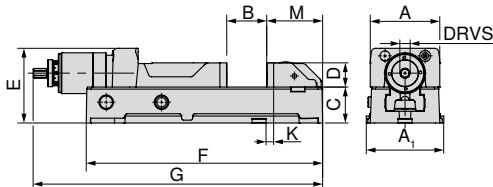

A	A ₁	B	C ^{+0/-0.02}	D	E	F	G _{max.}	K ^{±0.015}	M	DRVS	MXC	WT	80 892 ...
mm	mm	mm	mm	mm	mm	mm	mm	mm	mm	mm	kN	kg	EUR Y4
100	112	0 - 159	52	35	108	342	521	11	81	12	4 - 30	20	2.050,00 100
125	140	0 - 201	62	40	118	400	584	28	85	12	4 - 40	27	2.340,00 125
160	176	0 - 300	78	50	149	544	784	40	112	12	5 - 60	55	3.470,00 160

Vodnik po primežih

Mere spodnje strani	71	Pribor za sisteme	69-71
Splošni pribor	164-183		

Pregled sistemov čeljusti

Čeljusti za povečanje območja vpenjanja

▲ Cena za komplet (1 pomična in 1 nepomična čeljust)

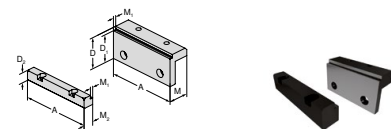

Za širino primeža	A	A ₁	D	D ₁	D ₂	E	M	M ₁	M ₂	EUR	Y4	NCG	H5G / +S / -Z	X5G-Z / -S	ESG 4	ESG 5	HDG 2	ZSG 4	ZSG mini	DSG 4	Verso	HSG	
100			56	50	22		37	5	19	366,00	80 892 225							●					
125			56	50	22		37	5	19	494,00	80 892 226							●					
160			71	65	23		47	5	23,5	537,00	80 892 227							●					

Prikaz s povečanim območjem vpenjanja

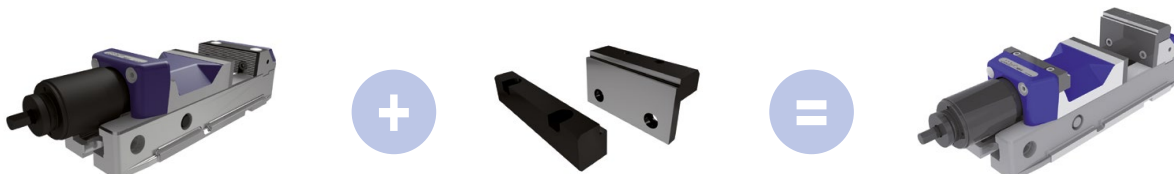

A	B	D	Katalogska št. – primež	Katalogska št. – čeljusti
100	118 - 278	56	80 892 100	80 892 225
125	137 - 338	56	80 892 125	80 892 226
160	169 - 470	71	80 892 160	80 892 227

SoloClamp – HDG 2

▲ Podaljšek osnovnega telesa

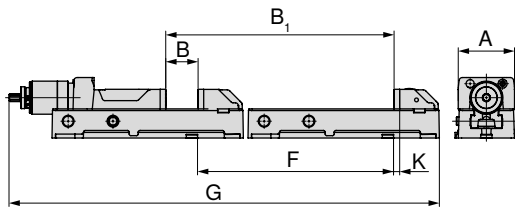
HDG
2

A	B	B ₁	F	G	K
mm	mm	mm	mm	mm	mm
100	0-159	350-509	450	871,3	11
125	0-201	410-611	410	994,1	28
160	0-300	550-850	550	1334,15	40

80 892 ...

EUR
Y4

1.160,00 51000

1.280,00 51100

1.740,00 51200

Prikaz s podaljškom osnovnega telesa

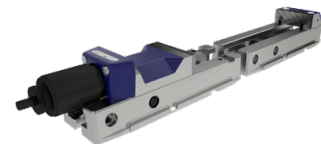

A	B	D	Katalogška št. – primež	Katalogška št. – podaljšek
100	350 - 509	35	80 892 100	80 892 51000
125	410 - 611	40	80 892 125	80 892 51100
160	550 - 850	50	80 892 160	80 892 51200

Mere spodnje strani za HDG 2

Širina osnovnega telesa

100 mm, 125 mm, 160 mm

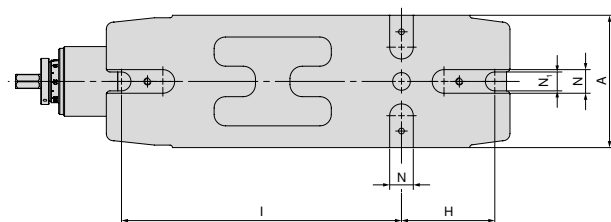

A mm	H mm	I mm	N _{H7} mm	N ₁ mm
100	80	240	20	15
125	100	280	20	18
160	130	380	20	22

Pregled pribora za sisteme

Kotni pogon

HDG
2

80 892 ...

Za širino
mmEUR
Y4

100/125

460,00

314

160

499,00

315

Pogonska ročica

▲ Za hitro nastavitvev

HDG
2

80 892 ...

Za širino
mmEUR
Y4

100/125

76,60

124

160

95,00

164

ZSG 4



Optimiziran centrični primež ZSG 4 – največja natančnost in procesna varnost

Nov centrični primež ZSG 4 je podedoval vse priljubljene lastnosti svojega predhodnika ter dvignil standard glede prijaznosti do uporabnika in vzdržljivosti. Pri posodobitvi priljubljenega centričnega primeža sta bila na prvem mestu optimizirano rokovanje in dolga življenjska doba.

Prednosti za vas:

- ▲ Posebej zasnovan za obdelavo z druge strani z visoko kotno natančnostjo
- ▲ Kompaktna oblika z idealno dostopnostjo
- ▲ Menjava čeljusti je hitra in enostavna z samo dvema vijakoma
- ▲ Enaka vpenjalna območja, znatno izboljšana interferenčna kontura, obsežen modularni obseg čeljusti
- ▲ Trajnostni model z ponikljanim osnovnim ohišjem zagotavlja dolgo življenjsko dobo



Vpenjanje/usmerjanje:



Pritrditev z vpenjalnim sistemom z ničelno točko
ZSG 4 – 80 mm L-130 mm + L-190 mm
ZSG 4 – 125 mm L-160 mm + L-235 mm

1 vpenjalni čep + indeksirni čep MNG



Pritrditev z vpenjalnim sistemom z ničelno točko
ZSG 4 – 125 mm + L-300 mm
ZSG 4 – 160 mm + L-280 mm + L-480 mm

2 vpenjalna čepa



Vse različice so opremljene s preciznimi izvrtinami $\text{Ø}12^{\text{H}8}$, ki omogočajo natančno pozicioniranje ZSG 4. Vse različice je mogoče pritrditi od zgoraj z vijaki skozi osnovno telo.

Vpenjanje/usmerjanje:



ZSG 4 – 125 mm L-235 mm + L-300 mm
ZSG 4 – 160 mm L-280 mm + L-480 mm

Te 4 različice je mogoče alternativno vpeti tudi z vpenjalnimi sponami.



ZSG 4 – 80 mm L-130 mm + L-190 mm
ZSG 4 – 125 mm L-160 mm + L-235 mm + L-300 mm
ZSG 4 – 160 mm L-280 mm

Vseh 5 različic je na voljo tudi z vpenjalno izvrtino za vpenjalni sistem z ničelno točko LANG.

Vpenjalna sila:

Zatezni moment / vpenjalna sila ZSG 4 – 80 mm

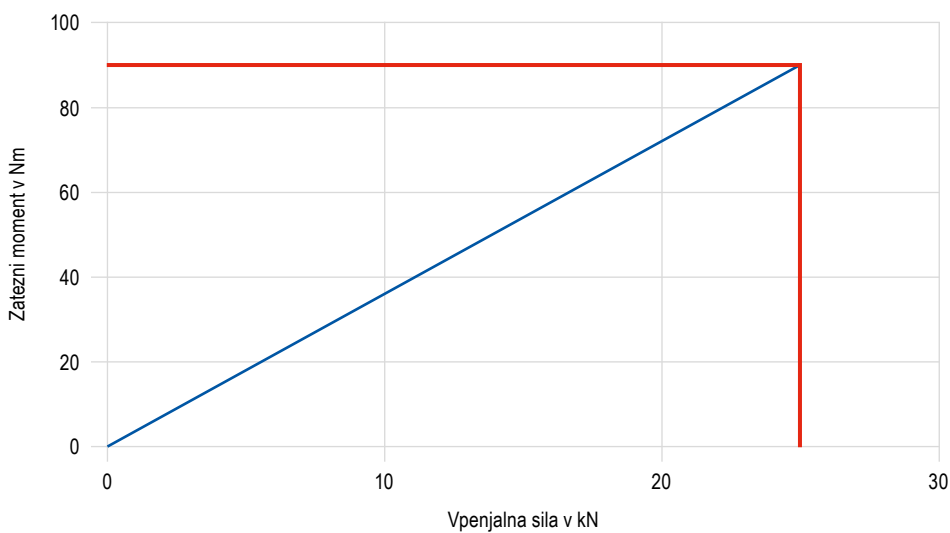

Vpenjalna sila:

Zatezni moment / vpenjalna sila ZSG 4 – 125 mm

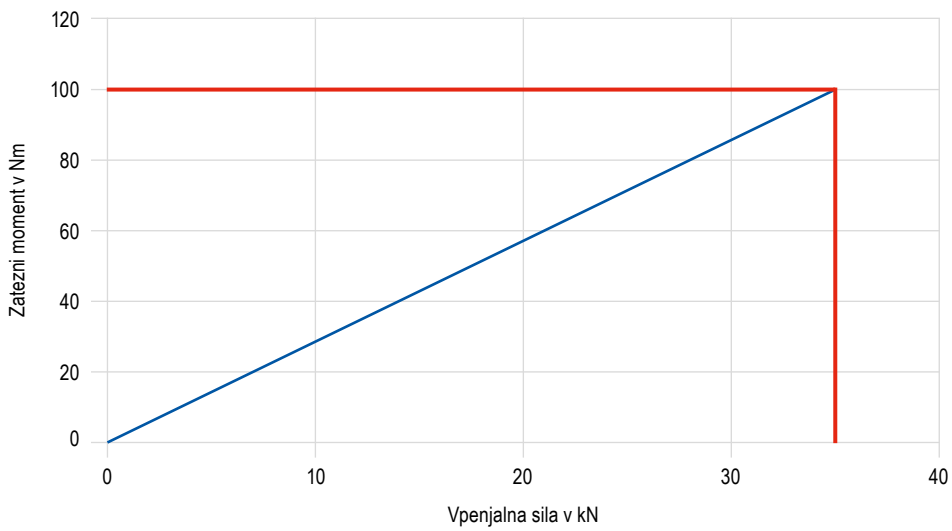

Zatezni moment / vpenjalna sila ZSG 4 – 160 mm

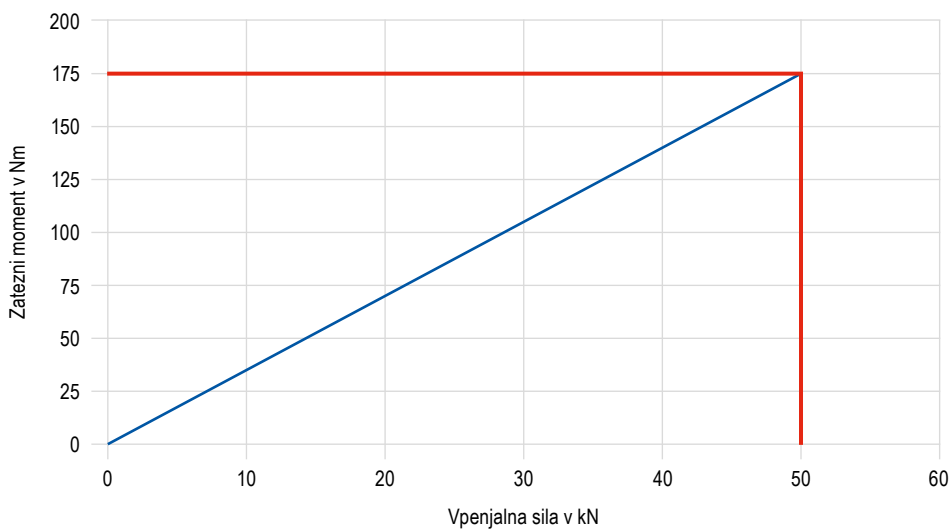

CentriClamp – ZSG 4

- ▲ oklopljen centrični primež
- ▲ brez sistemskih čeljusti
- ▲ vreteno s krogličnimi ležaji
- ▲ natančnost ponovitve med postopki vpenjanja $\pm 0,01$ mm
- ▲ primerno za PNG in MNG

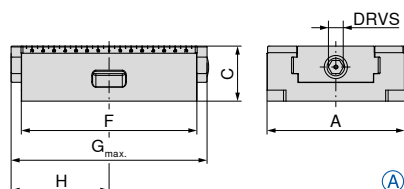
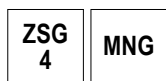

Notranje aktivacijsko vreteno

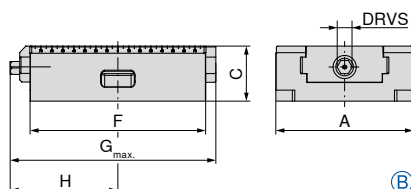

Zunanje aktivacijsko vreteno



A mm	C _{±0,01} mm	F mm	G _{max.} mm	H mm	DRVS mm	MXC kN	WT kg	Oznaka	80 878 ...	
									EUR	Y4
80	50	130	157	81	12	25	3,1	A	553,00	08500
80	50	190	206	104	12	25	4,5	B	665,00	08600
125	50	160	200	111,5	12	35	6,3	A	726,00	15000
125	50	235	272	143,5	12	35	9,5	B	927,00	15100
125	50	300	340	181	12	35	12,5	B	1.130,00	15200
160	70	280	315	172	14	50	25,0	A	1.710,00	26100
160	70	480	524	276	14	50	35,0	B	3.230,00	26200

Primerno za vpenjalni sistem z ničelno točko				MNG	MNG mini	PNG	LANG Quick Point	
Kataloška št.	Tip	Širina v mm	Dolžina v mm				96 x 96	52 x 52
80 878 08500	ZSG 4	80	130	✓	✓	✗	✗	✓
80 878 08600		80	190	✓	✗	✓	✗	✓
80 878 15000		125	160	✓	✗	✓	✓	✓
80 878 15100		125	235	✓	✗	✓	✓	✗
80 878 15200		125	300	✓	✗	✓	✓	✗
80 878 26100		160	280	✓	✗	✓	✓	✗
80 878 26200		160	480	✓	✗	✓	✗	✗

Vodnik po primežih

Mere spodnje strani	78+79	Preglednice z merami za različne čeljusti	80-83
Pribor za sisteme	85-90	Vpenjalni sistem z ničelno točko MNG/PNG	134-163
Splošni pribor	164-183		

CentriClamp – ZSG 4

- ▲ oklopljen centrični primež
- ▲ s prijemalnimi vpenjalnimi čeljustmi, 3 mm
- ▲ vreteno s krogličnimi ležaji
- ▲ natančnost ponovitve med postopki vpenjanja $\pm 0,01$ mm
- ▲ primerno za PNG in MNG

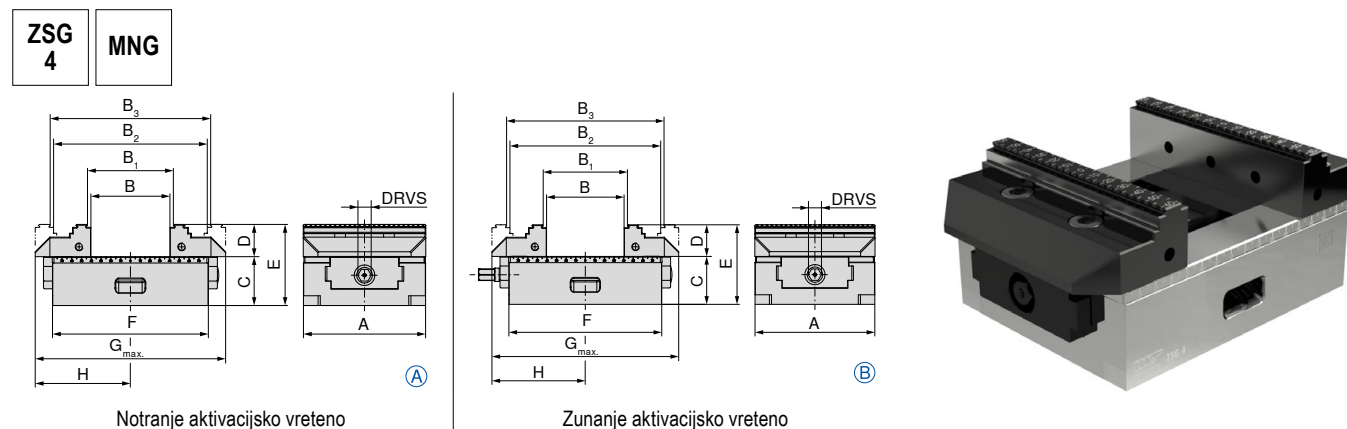

Notranje aktivacijsko vreteno

Zunanje aktivacijsko vreteno

A	B	B ₁	B ₂	B ₃	C _{±0,01}	D	E	F	G _{max}	H	DRVS	MXC	WT	Oznaka	80 878 ...
mm	mm	mm	mm	mm	mm	mm	mm	mm	mm	mm	mm	kN	kg		EUR
80	0 - 59	4 - 63	59 - 117	63 - 121	50	28	78	130	157	81	12	25	3,9	A	Y4 777,00 08700
80	0 - 123	4 - 127	59 - 181	63 - 185	50	28	78	190	206	104	12	25	5,5	B	889,00 08800
125	0 - 80	8 - 87	77 - 156	84 - 163	50	33	83	160	208	111,5	12	35	8,7	A	980,00 15300
125	0 - 155	8 - 162	77 - 218	84 - 225	50	33	83	235	272	143,5	12	35	12,0	B	1.180,00 15400
125	0 - 220	8 - 227	77 - 296	84 - 303	50	33	83	300	348	181	12	35	14,0	B	1.390,00 15500

1 Tu ne ustrezajo obrnljive čeljusti v višini 40 mm; če jih potrebujete, uporabite obrnljive čeljusti D = 40 mm (80 878 520).

Primerno za vpenjalni sistem z ničelno točko							LANG Quick Point		LANG Quick Point	
Kataloška št.	Tip	Širina v mm	Dolžina v mm	MNG	MNG mini	PNG	96 x 96	52 x 52		
80 878 08700	ZSG 4	80	130	✓	✓	✗	✗	✓		
80 878 08800		80	190	✓	✗	✓	✗	✓		
80 878 15300		125	160	✓	✗	✓	✓	✓		
80 878 15400		125	235	✓	✗	✓	✓	✗		
80 878 15500		125	300	✓	✗	✓	✓	✗		

Vodnik po primežih

Mere spodnje strani	78-79	Preglednice z merami za različne čeljusti	80-83
Pribor za sisteme	85-90	Vpenjalni sistem z ničelno točko MNG/PNG	134-163
Splošni pribor	164-183		

CentriClamp – ZSG 4

- ▲ oklopljen centrični primež za Erowa ITS 148
- ▲ brez sistemskih čeljusti
- ▲ vreteno s krogličnimi ležaji
- ▲ natančnost ponovitve med postopki vpenjanja $\pm 0,01$ mm

ZSG 4	MNG
----------	-----

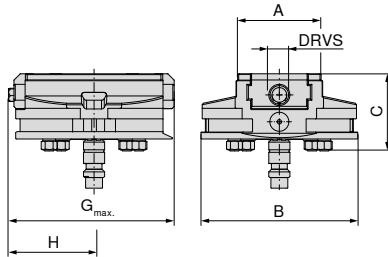

A	B	C	G _{max.}	H	DRVS	MXC	WT
mm	mm	mm	mm	mm	mm	kN	kg
80	148	73	157	81	12	25	5,6

80 878 ...

EUR
Y4

1.370,00 08900

Vodnik po primežih

Mere spodnje strani	78+79	Preglednice z merami za različne čeljusti	80-83
Pribor za sisteme	85-90	Vpenjalni sistem z ničelno točko MNG/PNG	134-163
Splošni pribor	164-183		

Mere spodnje strani ZSG 4

Širina osnovnega telesa 80 mm
in dolžina 130 mm

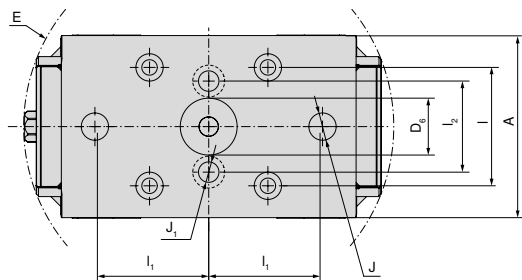

A	D ₆ H6	E	I ±0,015	I ₁ ±0,015	I ₂	J H7	J ₁
mm	mm	mm	mm	mm	mm	mm	mm
80	25	163	52	50	40	12	9

Širina osnovnega telesa 80 mm
in dolžina 190 mm

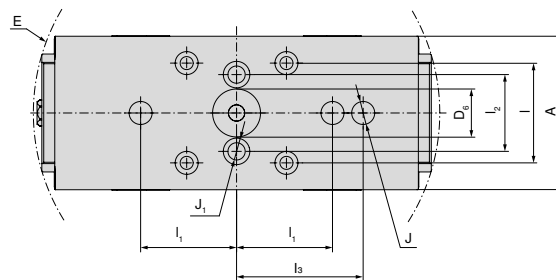

A	D ₆ H6	E	I ±0,015	I ₁ ±0,015	I ₂	I ₃ ±0,015	J H7	J ₁
mm	mm	mm	mm	mm	mm	mm	mm	mm
80	25	213	52	50	40	66	12	9

Širina osnovnega telesa 125 mm
in dolžina 160 mm

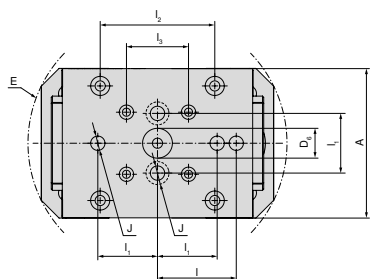

A	D ₆ H6	E	I ±0,015	I ₁ ±0,015	I ₂	I ₃ ±0,015	J H7
mm	mm	mm	mm	mm	mm	mm	mm
125	25	218	66	50	96	52	12

Širina osnovnega telesa 125 mm
in dolžina 235 mm

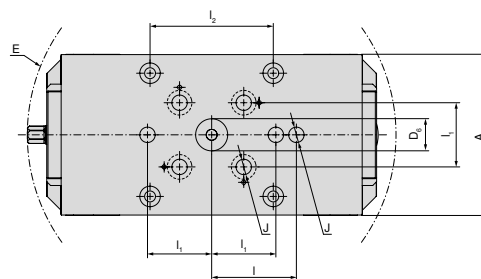

A	D ₆ H6	E	I ±0,015	I ₁ ±0,015	I ₂	J H7
mm	mm	mm	mm	mm	mm	mm
125	25	288	66	50	96	12

Širina osnovnega telesa 125 mm
in dolžina 300 mm

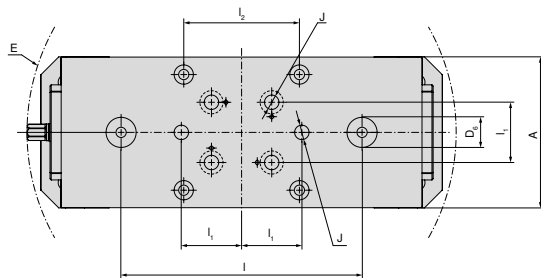

A	D ₆ H6	E	I ±0,015	I ₁ ±0,015	I ₂	J H7
mm	mm	mm	mm	mm	mm	mm
125	25	357	200	50	96	12

Mere spodnje strani ZSG 4

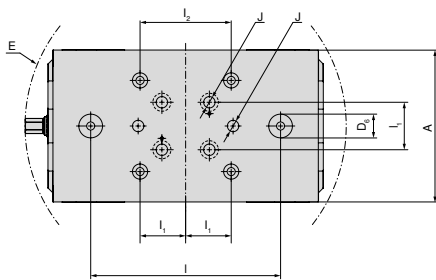
Širina osnovnega telesa 160 mm
in dolžina 280 mm

A	D ₆ H6	E	I _{±0,015}	I _{1 ±0,015}	I ₂	J H7
mm	mm	mm	mm	mm	mm	mm
160	25	339	200	50	96	12

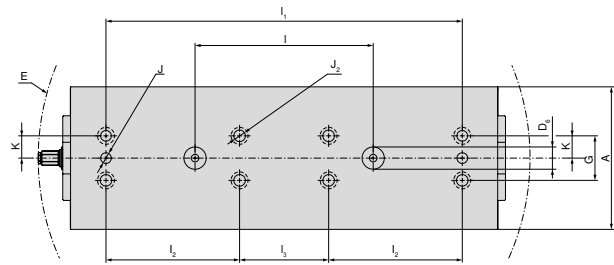
Širina osnovnega telesa 160 mm
in dolžina 480 mm

A	D ₆ H6	E	I _{±0,015}	I _{1 ±0,015}	I ₂	I _{3 ±0,015}	J H7	J ₂ F7	K _{±0,02}	G
mm	mm	mm	mm	mm	mm	mm	mm	mm	mm	mm
160	25	553	200	400	150	100	12	12	25	50

Preglednica z merami ZSG 4 za različne čeljusti

S kombiniranimi čeljustmi

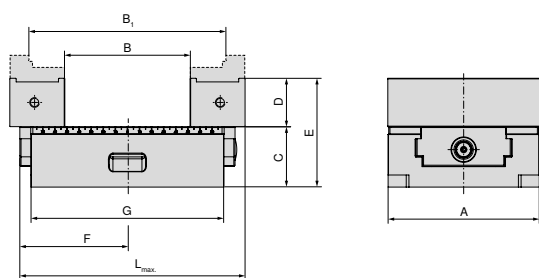

A mm	B mm	B ₁ mm	C mm	D mm	E mm	F mm	G mm	L _{max} mm	Kataloška št. Sistemske čeljusti
125	23 - 103	82 - 161	50	40	90	111,5	160	208	2 x 80 878 530
125	23 - 165	82 - 223	50	40	90	143,5	235	272	2 x 80 878 530
125	23 - 241	82 - 300	50	40	90	181	300	348	2 x 80 878 530

Z vrtljivo in adaptersko ploščo

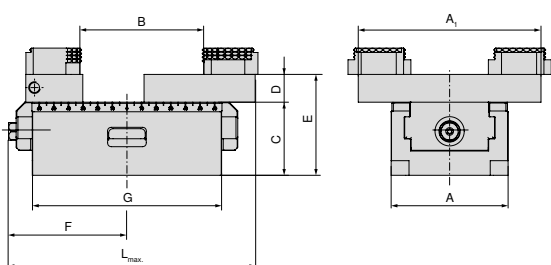

A mm	A ₁ mm	B mm	C mm	D mm	E mm	F mm	G mm	L _{max} mm	Kataloška št. Sistemske čeljusti
80	125	3 - 84	50	28	78	81	130	157	80 878 890 + 80 878 870
80	125	3 - 145	50	28	78	104	190	206	80 878 890 + 80 878 870
125	180	7 - 126	50	22	90	111,5	160	212	80 878 590 + 80 878 570
125	180	7 - 207	50	22	90	143,5	235	272	80 878 590 + 80 878 570
125	180	7 - 250	50	22	90	181	300	352	80 878 590 + 80 878 570
160	256	16 - 292	70	22	110	170	280	315	80 878 690 + 80 878 670
160	256	16 - 406	70	22	110	276	480	524	80 878 690 + 80 878 670

Z aluminijastimi čeljustmi

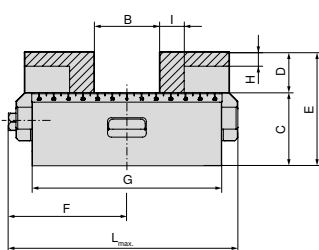

A mm	B mm	C mm	D mm	E mm	F mm	G mm	H mm	I mm	L _{max} mm	Kataloška št. Sistemske čeljusti
80	0 - 44	50	28	78	81	130	10	17	157	2 x 80 878 850
80	0 - 108	50	28	78	104	190	10	17	206	2 x 80 878 850
125	0 - 58	50	40	90	111,5	160	17	27	208	2 x 80 878 550
125	0 - 133	50	40	90	143,5	235	17	27	272	2 x 80 878 550
125	0 - 198	50	40	90	181	300	17	27	348	2 x 80 878 550
160	0 - 123	70	50	120	170	280	26	25	315	2 x 80 878 305
160	10 - 336	70	50	120	276	480	26	25	524	2 x 80 878 305

Preglednica z merami ZSG 4 za različne čeljusti

S 5-osnimi čeljustmi

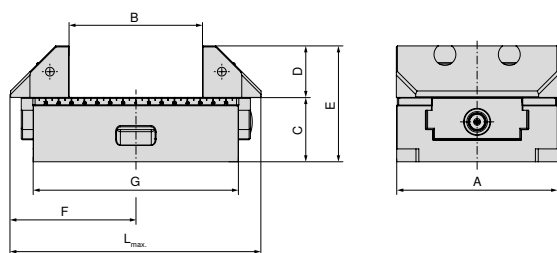

A mm	B mm	C mm	D mm	E mm	F mm	G mm	L _{max.} mm	Kataloška št. Sistemske čeljusti
125	22 - 102	50	40	90	115,5	160	208	2 x 80 878 625
125	22 - 165	50	40	90	143,5	235	272	2 x 80 878 625
125	22 - 242	50	40	90	181	300	348	2 x 80 878 625
160	15 - 140	70	50	120	170	280	315	2 x 80 878 660
160	28 - 354	70	50	120	276	480	524	2 x 80 878 660

S 5-osnimi prijemalnimi čeljustmi, stopnja 3 mm, širina 65 mm

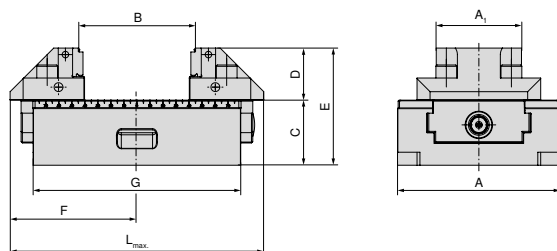

A mm	A ₁ mm	B mm	C mm	D mm	E mm	F mm	G mm	L _{max.} mm	Kataloška št. Sistemske čeljusti
125	65	8 - 87	50	40	90	115,5	160	208	2 x 80 878 665
125	65	8 - 162	50	40	90	143,5	235	272	2 x 80 878 665
125	65	8 - 227	50	40	90	181	300	348	2 x 80 878 665

Z obrnljivimi prijemalnimi čeljustmi, stopnja 3 mm, širina 65 mm

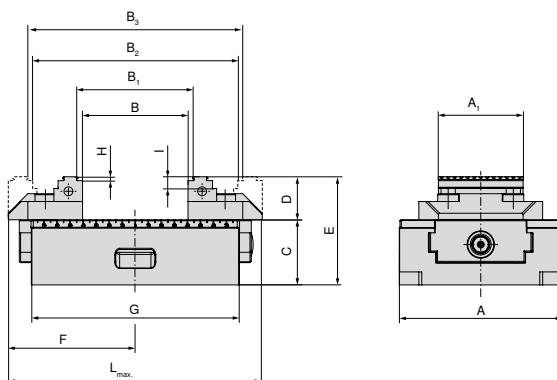

A mm	A ₁ mm	B mm	B ₁ mm	B ₂ mm	B ₃ mm	C mm	D mm	E mm	F mm	G mm	H mm	I mm	L _{max.} mm	Kataloška št. Sistemske čeljusti
125	65	0 - 80	8 - 87	77 - 156	84 - 163	50	33	83	111,5	160	3	9	208	2 x 80 878 51900
125	65	0 - 142	8 - 149	77 - 218	84 - 225	50	33	83	143,5	235	3	9	272	2 x 80 878 51900
125	65	0 - 220	8 - 227	77 - 296	84 - 303	50	33	83	181	300	3	9	348	2 x 80 878 51900

Preglednica z merami ZSG 4 za različne čeljusti

Z obrnljivimi čeljustmi, stopnja 3 mm

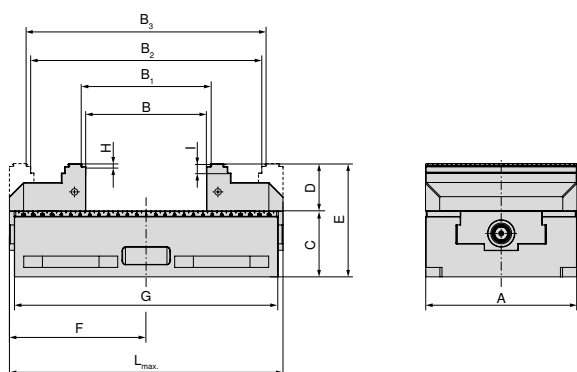

A mm	B mm	B ₁ mm	B ₂ mm	B ₃ mm	C mm	D mm	E mm	F mm	G mm	H mm	I mm	L _{max} mm	Katalogška št. Sistemske čeljusti
160	0 - 127	8 - 134	118 - 244	125 - 251	70	50	120	170	280	3	10	315	2 x 80 878 610
160	15 - 341	22 - 348	132 - 458	139 - 465	70	50	120	276	480	3	10	524	2 x 80 878 610

Z obrnljivimi prijemalnimi čeljustmi, stopnja 3 mm, višina 40 mm

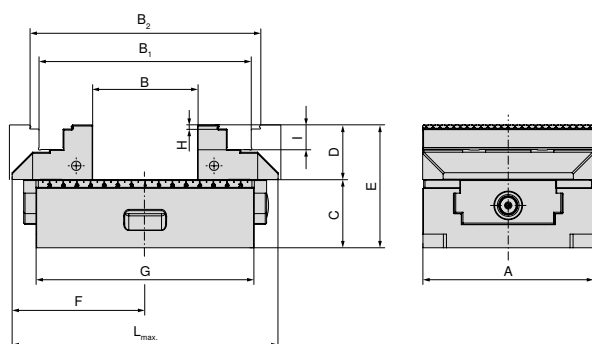

A mm	B mm	B ₁ mm	B ₂ mm	C mm	D mm	E mm	F mm	G mm	H mm	I mm	L _{max} mm	Katalogška št. Sistemske čeljusti
125	0 - 75	75 - 154	88 - 166	50	40	90	111,5	160	3	9	208	2 x 80 878 520
125	0 - 138	75 - 217	88 - 229	50	40	90	143,5	235	3	9	272	2 x 80 878 520
125	0 - 215	75 - 294	88 - 306	50	40	90	181	300	3	9	348	2 x 80 878 520

S 6-kratnim sistemom čeljusti za širino čeljusti 125 mm

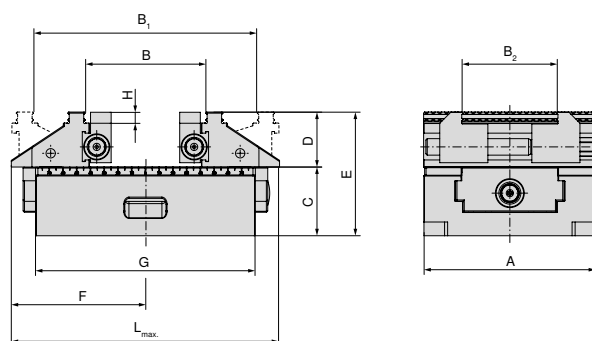

A mm	B mm	B ₁ mm	B ₂ mm	C mm	D mm	E mm	F mm	G mm	H mm	L _{max} mm	Katalogška št. Sistemske čeljusti
125	39 - 86	83 - 161	37 - 101	50	40	90	111,5	160	8	209	80 878 525
125	39 - 149	83 - 224	37 - 101	50	40	90	143,5	235	8	272	80 878 525
125	39 - 226	83 - 301	37 - 101	50	40	90	181	300	8	349	80 878 525

Preglednica z merami ZSG 4 za različne čeljusti

S srednjo čeljustjo, stopnja 3 mm (višina 28 mm / 33 mm) za širino čeljusti 125 mm

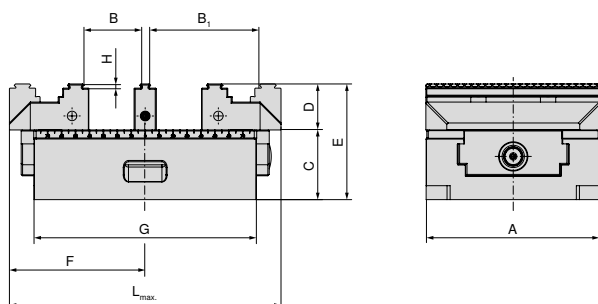

A mm	B mm	B ₁ mm	C mm	D mm	E mm	F mm	G mm	H mm	L _{max.} mm	Kataloška št. Sistemske čeljusti
80	8 - 28	37 - 57	50	28	78	81	130	3	157	2 x 80 878 810 + 80 878 31200
80	14 - 22	31 - 51	50	28	78	81	130	3	157	2 x 80 878 810 + 80 878 33400
80	8 - 58	37 - 87	50	28	78	104	190	3	206	2 x 80 878 810 + 80 878 31200
80	14 - 52	31 - 81	50	28	78	104	190	3	206	2 x 80 878 810 + 80 878 33400
125	9 - 40	47 - 78	50	33	83	111,5	160	3	208	2 x 80 878 510 + 80 878 31300
125	15 - 34	41 - 72	50	33	83	111,5	160	3	208	2 x 80 878 510 + 80 878 33500
125	9 - 72	47 - 110	50	33	83	143,5	235	3	272	2 x 80 878 510 + 80 878 31300
125	15 - 66	41 - 104	50	33	83	143,5	235	3	272	2 x 80 878 510 + 80 878 33500
125	9 - 110	47 - 148	50	33	83	181	300	3	348	2 x 80 878 510 + 80 878 31300
125	15 - 104	41 - 142	50	33	83	181	300	3	348	2 x 80 878 510 + 80 878 33500

S čeljustjo s prizmo, pomična – vodoravno in navpično prizma

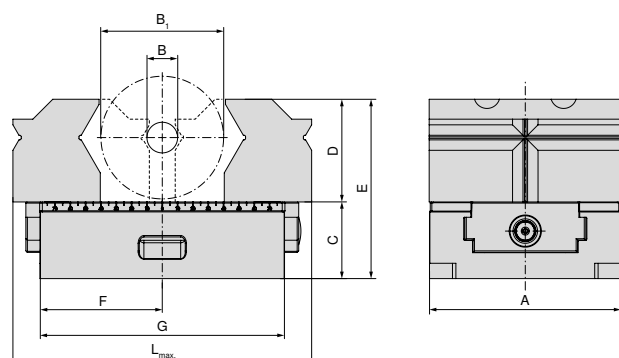

A mm	B mm	B ₁ mm	C mm	D mm	E mm	F mm	G mm	L _{max.} mm	Kataloška št. Sistemske čeljusti
80	10 - 28	20 - 60	50	52	102	81	130	157	2 x 80 878 31800
80	10 - 28	20 - 60	50	52	102	104	190	206	2 x 80 878 31800
125	10 - 28	26 - 80	50	67	117	111,5	160	200	2 x 80 878 31900
125	10 - 28	26 - 80	50	67	117	143,5	235	272	2 x 80 878 31900
125	10 - 28	26 - 80	50	67	117	181	300	348	2 x 80 878 31900

Preglednica z merami ZSG 4 za različne čeljusti

S čeljustjo s prizmo, pomična – vodoravna prizma

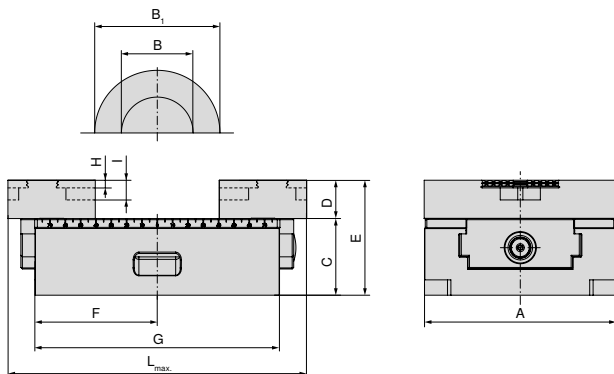

A mm	B mm	B ₁ mm	C mm	D mm	E mm	F mm	G mm	H mm	I mm	L _{max} mm	Kataloška št. Sistemske čeljusti
80	8 - 55	15 - 76	50	25	75	81	130	5	13	157	2 x 80 878 34000
80	8 - 55	15 - 76	50	25	75	104	190	5	13	206	2 x 80 878 34000
125	14 - 102	25 - 112	50	25	75	111,5	160	5	13	200	2 x 80 878 34100
125	14 - 124	25 - 165	50	25	75	143,5	235	5	13	272	2 x 80 878 34100
125	14 - 124	25 - 165	50	25	75	181	300	5	13	348	2 x 80 878 34100
160	22 - 158	32 - 170	70	30	100	145	280	5	13	290	2 x 80 878 34200
160	22 - 158	32 - 170	70	30	100	273	480	5	13	521	2 x 80 878 34200

Pregled sistemov čeljusti

5-osna čeljust, pomična

▲ Cena za kos

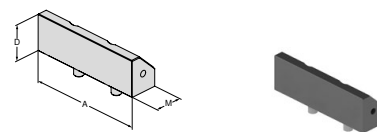

Za širino primeža	A	A ₁	D	D ₁	D ₂	E	M	M ₁	M ₂	EUR	Y4	NCG	H5G / -S / -Z	X5G-Z / -S	ESG 4	ESG 5	HDG 2	ZSG 4	ZSG mini	DSG 4	Verso	HSG	
125	125		40				45,5			225,00									●				
160	160		50				73			277,00									●				

5-osna čeljust, prijemalna, stopnja 3 mm, širina 65 mm, pomična

▲ Cena za kos

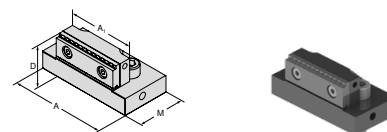

Za širino primeža	A	A ₁	D	D ₁	D ₂	E	M	M ₁	M ₂	EUR	Y4	NCG	H5G / -S / -Z	X5G-Z / -S	ESG 4	ESG 5	HDG 2	ZSG 4	ZSG mini	DSG 4	Verso	HSG	
125	95	65,5	40				57			260,00									●				

5-osna obrnljiva čeljust, prijemalna, stopnja 3 mm, širina 65 mm, pomična

▲ Obojstranska prijemalna stopnica

▲ Cena za kos

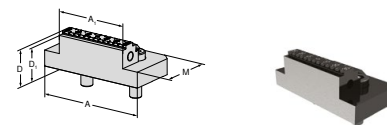

Za širino primeža	A	A ₁	D	D ₁	D ₂	E	M	M ₁	M ₂	EUR	Y4	NCG	H5G / -S / -Z	X5G-Z / -S	ESG 4	ESG 5	HDG 2	ZSG 4	ZSG mini	DSG 4	Verso	HSG	
125	95	65	33	30			57			196,00									●				

Obrnljiva čeljust, prijemalna, stopnja 3 mm, širina 40 mm, pomična

▲ Cena za kos

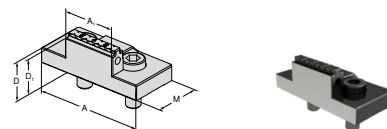

Za širino primeža	A	A ₁	D	D ₁	D ₂	E	M	M ₁	M ₂	EUR	Y4	NCG	H5G / -S / -Z	X5G-Z / -S	ESG 4	ESG 5	HDG 2	ZSG 4	ZSG mini	DSG 4	Verso	HSG	
80	80	40	28	25			40			180,00					●				●				

Obrnljiva čeljust, prijemalna, stopnja 3 mm, višina 40 mm, pomična

▲ Cena za kos

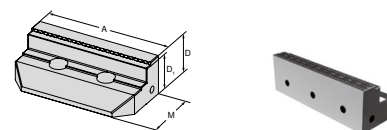

Za širino primeža	A	A ₁	D	D ₁	D ₂	E	M	M ₁	M ₂	EUR	Y4	NCG	H5G / -S / -Z	X5G-Z / -S	ESG 4	ESG 5	HDG 2	ZSG 4	ZSG mini	DSG 4	Verso	HSG	
125	125		40	37			59			282,00									●				

Pregled sistemov čeljusti

Obrnljiva čeljust, prijemalna, stopnja 3 mm, pomična

▲ Cena za kos

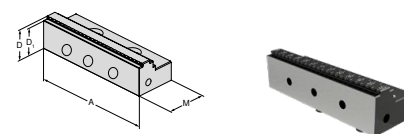

Za širino primeža	A	A ₁	D	D ₁	D ₂	E	M	M ₁	M ₂	EUR	Y4	NCG	H5G / -S / -Z	X5G-Z / -S	ESG 4	ESG 5	HDC 2	ZSG 4	ZSG mini	DSG 4	Verso	HSG	
80	80		28	25			40			135,00	80 878 810				●	●		●		●			
125	125		33	30			57			151,00	80 878 510				●	●		●					
160	160		50	47			81			404,00	80 878 610				●	●		●					

Obrnljiva čeljust, prijemalna, stopnja 5 mm, pomična

▲ Cena za kos

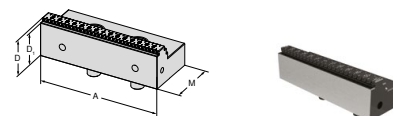

Za širino primeža	A	A ₁	D	D ₁	D ₂	E	M	M ₁	M ₂	EUR	Y4	NCG	H5G / -S / -Z	X5G-Z / -S	ESG 4	ESG 5	HDC 2	ZSG 4	ZSG mini	DSG 4	Verso	HSG	
80	80		28	23			41			160,00	80 878 81400				●			●		●			
125	125		33	28			57			177,00	80 878 51400				●			●					
160	160		50	45			81			404,00	80 878 34300				●			●					

Obrnljiva čeljust, prijemalna, za aluminij in umetno maso

▲ Cena za kos

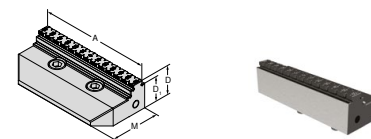

Za širino primeža	A	A ₁	D	D ₁	D ₂	E	M	M ₁	M ₂	EUR	Y4	NCG	H5G / -S / -Z	X5G-Z / -S	ESG 4	ESG 5	HDC 2	ZSG 4	ZSG mini	DSG 4	Verso	HSG	
80	80		28	23			40			191,00	80 878 81500							●					
125	125		33	28			57			210,00	80 878 51500							●					

Reliefni profil obrnljive čeljusti, pomična

▲ Cena za kos

▲ Primerna za LANG-ov predodtisnjeni reliefni profil

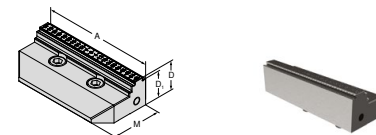

Za širino primeža	A	A ₁	D	D ₁	D ₂	E	M	M ₁	M ₂	EUR	Y4	NCG	H5G / -S / -Z	X5G-Z / -S	ESG 4	ESG 5	HDC 2	ZSG 4	ZSG mini	DSG 4	Verso	HSG	
80	80		28	25			40			170,00	80 878 81800							●					
125	125		33	30			57			233,00	80 878 51800							●					

Pregled sistemov čeljusti

Obrnljiva čeljust, prijemalo s karbidno t., stopnja 3 mm, premična

▲ Cena za kos

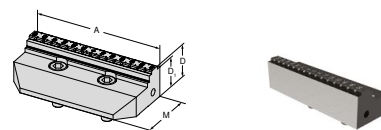

Za širino primeža	A	A ₁	D	D ₁	D ₂	E	M	M ₁	M ₂	EUR	Y4	NCG	H5G / -S / -Z	X5G-Z / -S	ESG 4	ESG 5	HDG 2	ZSG 4	ZSG mini	DSG 4	Verso	HSG	
80	80		28	25			40			242,00	80 878 81600								●				
125	125		33	30			57			342,00	80 878 51600								●				
160	160		50	47			81			537,00	80 878 31700								●				

Obrnljiva čeljust, prijemalo s karbidno t., stopnja 5 mm, premična

▲ Cena za kos

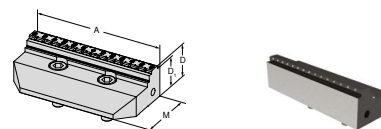

Za širino primeža	A	A ₁	D	D ₁	D ₂	E	M	M ₁	M ₂	EUR	Y4	NCG	H5G / -S / -Z	X5G-Z / -S	ESG 4	ESG 5	HDG 2	ZSG 4	ZSG mini	DSG 4	Verso	HSG	
80	80		28	23			40			242,00	80 878 81700								●				
125	125		33	28			57			342,00	80 878 51700								●				

Obrnljiva čeljust, prijemalo s karbidno t., stopnja 3 mm, širina 40 mm, pomična

▲ Cena za kos

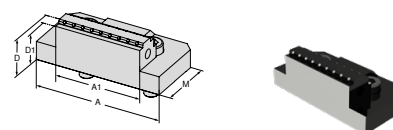

Za širino primeža	A	A ₁	D	D ₁	D ₂	E	M	M ₁	M ₂	EUR	Y4	NCG	H5G / -S / -Z	X5G-Z / -S	ESG 4	ESG 5	HDG 2	ZSG 4	ZSG mini	DSG 4	Verso	HSG	
80	80	40	28	25			40			234,00	80 878 33200								●				

Obrnljiva čeljust, prijemalo s karbidno t., stopnja 3 mm, širina 65 mm, pomična

▲ Cena za kos

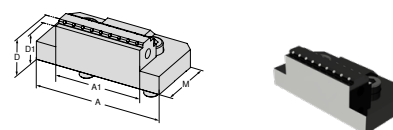

Za širino primeža	A	A ₁	D	D ₁	D ₂	E	M	M ₁	M ₂	EUR	Y4	NCG	H5G / -S / -Z	X5G-Z / -S	ESG 4	ESG 5	HDG 2	ZSG 4	ZSG mini	DSG 4	Verso	HSG	
125	125	65	33	30			57			324,00	80 878 33300								●				

Obrnljiva čeljust, gladka, premična

▲ Cena za kos

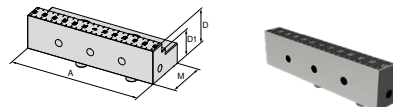

Za širino primeža	A	A ₁	D	D ₁	D ₂	E	M	M ₁	M ₂	EUR	Y4	NCG	H5G / -S / -Z	X5G-Z / -S	ESG 4	ESG 5	HDG 2	ZSG 4	ZSG mini	DSG 4	Verso	HSG	
80	80		28	20			40			195,00	80 878 34700					●			●				
125	125		33	25			57			378,00	80 878 34600					●			●				

Pregled sistemov čeljusti

Stopničasta čeljust, gladka, pomična

▲ Cena za kos

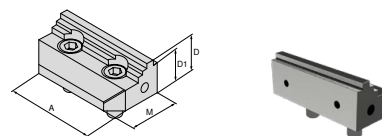

Za širino primeža	A	A ₁	D	D ₁	D ₂	E	M	M ₁	M ₂	EUR	Y4	NCG	H5G / -S / -Z	X5G-Z / -S	ESG 4	ESG 5	HDG 2	ZSG 4	ZSG mini	DSG 4	Verso	HSG	
80	80		28	24			40			247,00	80 878 34400								●				
125	125		33	27			57			347,00	80 878 34500								●				

Sredinska čeljust, prijemalna, stopnja 3 mm, ozka

▲ Cena za kos

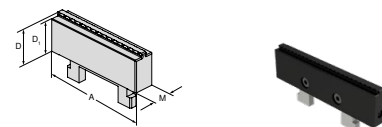

Za širino primeža	A	A ₁	D	D ₁	D ₂	E	M	M ₁	M ₂	EUR	Y4	NCG	H5G / -S / -Z	X5G-Z / -S	ESG 4	ESG 5	HDG 2	ZSG 4	ZSG mini	DSG 4	Verso	HSG	
80	80		28	25			16			110,00	80 878 31200								●				
125	125		33	30			16			155,00	80 878 31300								●				

Sredinska čeljust, prijemalna, stopnja 3 mm, široka

▲ Cena za kos

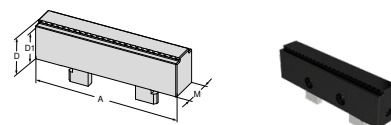

Za širino primeža	A	A ₁	D	D ₁	D ₂	E	M	M ₁	M ₂	EUR	Y4	NCG	H5G / -S / -Z	X5G-Z / -S	ESG 4	ESG 5	HDG 2	ZSG 4	ZSG mini	DSG 4	Verso	HSG	
80	80		28	25			24			110,00	80 878 33400								●				
125	125		33	30			26			155,00	80 878 33500								●				

Čeljust s prizmo, pomična

▲ z vodoravno in navpično prizmo

▲ Cena za kos

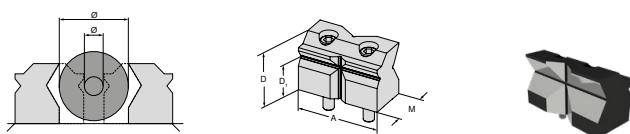

Ø Za vpenjalni premer	A	A ₁	D	D ₁	D ₂	E	M	M ₁	M ₂	EUR	Y4	NCG	H5G / -S / -Z	X5G-Z / -S	ESG 4	ESG 5	HDG 2	ZSG 4	ZSG mini	DSG 4	Verso	HSG	
10 - 60	80		52	32			38,5			319,00	80 878 31800								●				
10 - 80	125		67	42			57			486,00	80 878 31900								●				

Pregled sistemov čeljusti

Čeljust s prizmo, pomična

- ▲ z vodoravno prizmo
- ▲ Cena za kos

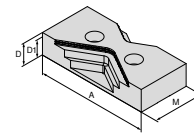
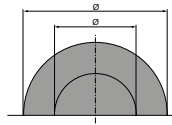

Ø Za vpenjalni premer	A	A ₁	D	D ₁	D ₂	E	M	M ₁	M ₂	EUR	Y4	NCG	H5G / -S / -Z	X5G-Z / -S	ESG 4	ESG 5	HDG 2	ZSG 4	ZSG mini	DSG 4	Verso	HSG	
15 - 75	80		25	20			40			171,00													
25 - 110	125		25	20			57			220,00									●				
30 - 170	160		30	25			81			285,00									●				

Kombinirana čeljust, pomična

- ▲ Cena za kos

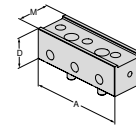

Za širino primeža	A	A ₁	D	D ₁	D ₂	E	M	M ₁	M ₂	EUR	Y4	NCG	H5G / -S / -Z	X5G-Z / -S	ESG 4	ESG 5	HDG 2	ZSG 4	ZSG mini	DSG 4	Verso	HSG	
125	125		40				45,5			173,00									●				

Čeljust, prijemalna, VS

- ▲ Cena za kos
- ▲ VS = povečano območje vpenjanja

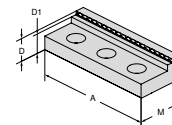

Za širino primeža	A	A ₁	D	D ₁	D ₂	E	M	M ₁	M ₂	EUR	Y4	NCG	H5G / -S / -Z	X5G-Z / -S	ESG 4	ESG 5	HDG 2	ZSG 4	ZSG mini	DSG 4	Verso	HSG	
125	125		22	17			45			99,30									●				

Čeljust, gladka, VS, prevlečena z WC (volframovim karbidom)

- ▲ Povečano območje vpenjanja za končno obdelavo in 2. stran
- ▲ Cena za kos

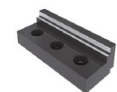
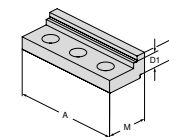

Za širino primeža	A	A ₁	D	D ₁	D ₂	E	M	M ₁	M ₂	EUR	Y4	NCG	H5G / -S / -Z	X5G-Z / -S	ESG 4	ESG 5	HDG 2	ZSG 4	ZSG mini	DSG 4	Verso	HSG	
125	125		19	14			45			239,00									●				

Aluminijasta čeljust, pomična

- ▲ Za proizvodnjo oblikovnih čeljusti
- ▲ Cena za kos

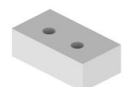
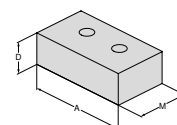

Za širino primeža	A	A ₁	D	D ₁	D ₂	E	M	M ₁	M ₂	EUR	Y4	NCG	H5G / -S / -Z	X5G-Z / -S	ESG 4	ESG 5	HDG 2	ZSG 4	ZSG mini	DSG 4	Verso	HSG	
80	80		28				48			86,40					●	●			●				
125	125		40				68			98,30					●	●			●				
160	160		50				85			124,00					●	●			●				

Pregled sistemov čeljusti

Čeljust v mehki izvedbi, jeklo, pomična

- ▲ Material: 16MnCr5
- ▲ Za proizvodnjo oblikovnih čeljusti
- ▲ Cena za kos

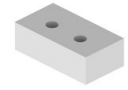
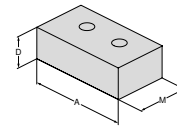

Za širino primeža	A	A ₁	D	D ₁	D ₂	E	M	M ₁	M ₂	EUR	Y4	NCG	H5G / -S / -Z	X5G-Z / -S	ESG 4	ESG 5	HDG 2	ZSG 4	ZSG mini	DSG 4	Verso	HSG	
80	80		28				48			89,10	80 878 32000				●	●		●					
125	125		40				68			112,00	80 878 32100				●	●		●					

Vrtljiva čeljust, pomična

- ▲ Za vpenjanje 6-delnih obrnljivih čeljusti
- ▲ Cena za kos

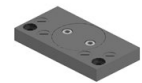
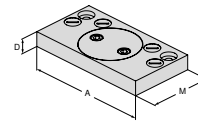

Za širino primeža	A	A ₁	D	D ₁	D ₂	E	M	M ₁	M ₂	EUR	Y4	NCG	H5G / -S / -Z	X5G-Z / -S	ESG 4	ESG 5	HDG 2	ZSG 4	ZSG mini	DSG 4	Verso	HSG	
80	125		19				76			409,00	80 878 870				●			●					
125	180		22				95			426,00	80 878 570				●			●					
160	256		22				170			726,00	80 878 670				●			●					

Adapterska čeljust

- ▲ Za vpenjanje 6-delnih obrnljivih čeljusti
- ▲ Cena za kos

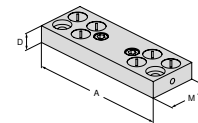

Za širino primeža	A	A ₁	D	D ₁	D ₂	E	M	M ₁	M ₂	EUR	Y4	NCG	H5G / -S / -Z	X5G-Z / -S	ESG 4	ESG 5	HDG 2	ZSG 4	ZSG mini	DSG 4	Verso	HSG	
80	125		19				39			290,00	80 878 890							●					
125	180		22				62			346,00	80 878 590							●					
160	256		22				125			484,00	80 878 690							●					

6-delni čeljustni nastavek

- ▲ 1 = Gladka, prevlečena z volframovim karbidom
- ▲ 2 = Prijemalo s stopnico 3 mm
- ▲ 3 = Prijemalo s stopnico 8 mm
- ▲ 4 = Prijemalo s stopnico 18 mm
- ▲ 5 = Prijemalo, okroglo, s stopnico 8 mm
- ▲ 6 = Prijemalo, okroglo
- ▲ M_{najv.} = 60 Nm
- ▲ Vklj. s pritrdilnimi vijaki

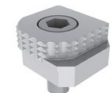
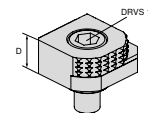

Za širino primeža	A	A ₁	D	D ₁	D ₂	E	M	M ₁	M ₂	EUR	Y4	NCG	H5G / -S / -Z	X5G-Z / -S	ESG 4	ESG 5	HDG 2	ZSG 4	ZSG mini	DSG 4	Verso	HSG	
			18							80,60	80 892 246	●	●	●	●	●	●	●	●	●	●	●	●

Pregled sistemov čeljusti

6-delni čeljustni nastavek, s prijemalom iz karbidne trdine

- ▲ 1 = gladka
- ▲ 2 = karbidno prijemalo
- ▲ 3 = karbidno prijemalo s stopnico 3 mm
- ▲ 4 = karbidno prijemalo s stopnico 8 mm
- ▲ 5 = karbidno prijemalo, okroglo, s stopnico 8 mm
- ▲ 6 = karbidno prijemalo, okroglo
- ▲ vklj. s pritrdilnimi vijaki

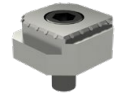
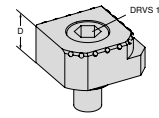

Za širino primeža	A	A ₁	D	D ₁	D ₂	E	M	M ₁	M ₂	EUR	Y4	NOG	H5G / -S / -Z	X5G-Z / -S	ESG 4	ESG 5	H5G 2	ZSG 4	ZSG mini	DSG 4	Verso	H5G	
			18							117,00	80 890 35300	●	●	●	●	●	●	●	●	●	●	●	●

6-kratni sistem čeljusti za širino čeljusti 125 mm

Obseg dobave:

2 sistema čeljusti z 2 paroma prečnih čeljusti v izvedbi s T-utori, vklj. s pritrdilnimi vijaki

ZSG
4

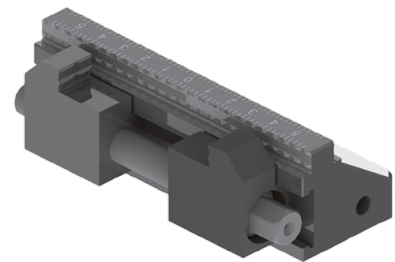
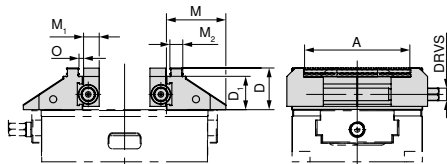

Za širino mm	A mm	D mm	D ₁ mm	M mm	M ₁ mm	M ₂ mm	O mm	DRVS mm	WT kg	80 878 ...
125	37 - 101	40	32	57	15	12,4	3,3	12	3,8	EUR Y4 1.720,00 525

ZSG mini



Centrični primež za manjše dele

ZSG mini v mehanski izvedbi z visoko vpenjalno silo in hitro menjavo čeljusti
Idealno za obdelavo surovcev in gotovih delov, večkratno vpenjanje in avtomatizacijo.

Prednosti za vas:

- ▲ Hitra menjava čeljusti brez orodja
- ▲ Kompaktnost in preciznost
- ▲ Najboljša dostopnost z vseh strani
- ▲ Širina čeljusti z možnostjo menjave (45 mm in 70 mm)
- ▲ Visoka vpenjalna sila in široko območje vpenjanja
- ▲ Vpenjalni sistem za avtomatizacijo
- ▲ Nerjavno in kaljeno osnovno telo



Vpenjanje/usmerjanje:



Vpenjanje z dvema vijakoma M6 od zgoraj skozi osnovno telo.



Vpenjanje z dvema vijakoma M6 od zgoraj skozi osnovno telo. Izravnavo se lahko izvede prek preciznih izvrtin s premerom 12^{H7}.



Obe izvedbi sta pripravljene za vpenjalni sistem z ničelno točko LANG Quick Point 52 × 52.

Vpenjalna sila:

Zatezni vrtilni moment/vpenjalna sila ZSG mini

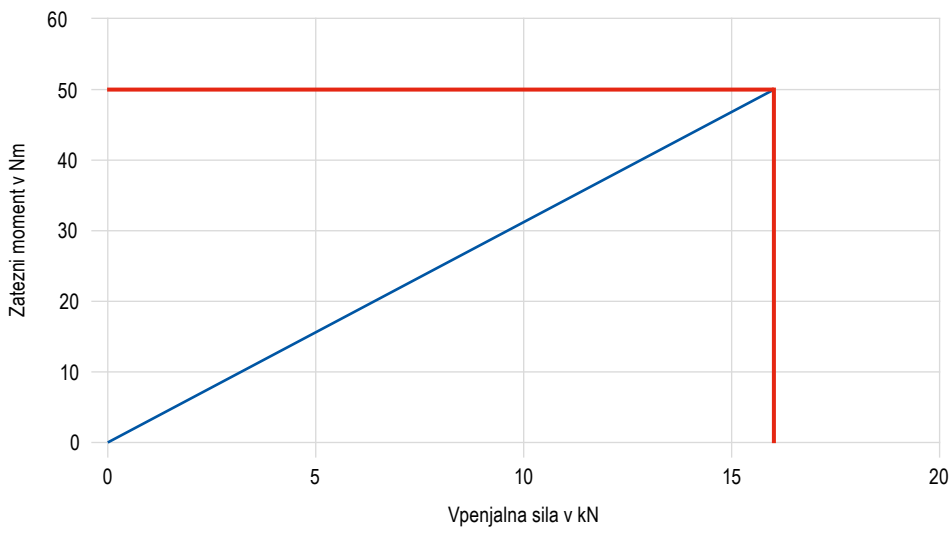

CentriClamp – ZSG mini

- ▲ Centrični primež za manjše dele
- ▲ brez sistemskih čeljusti
- ▲ hitra menjava čeljusti brez orodja
- ▲ kompaktnost in preciznost
- ▲ najboljša dostopnost z vseh strani
- ▲ širina čeljusti z možnostjo menjave (45 mm in 70 mm)
- ▲ nerjavno in kaljeno osnovno telo

Obseg dobave:

Osnovno telo ZSG mini z vretenom

ZSG
mini

MNG
mini

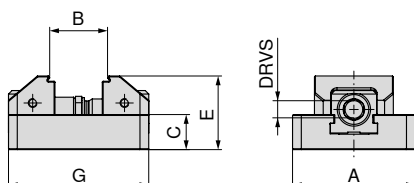

NEW

80 912 ...

EUR

Y4

420,00 07000

476,00 07100

A	B	C	E	G	MXC	DRVS	WT
mm	mm	mm	mm	mm	kN	mm	kg
70	7 - 57	20	42	80	16	11	0,9
70	7 - 77	20	42	100	16	11	1,1

Vodnik po primežih

Mere spodnje strani	94	Preglednice z merami za različne čeljusti	95-97
Pribor za sisteme	98-100	Vpenjalni sistem z ničelno točko MNG/PNG	134-163
Splošni pribor	164-183		

Mere spodnje strani za ZSG mini

Širina osnovnega telesa 70 mm

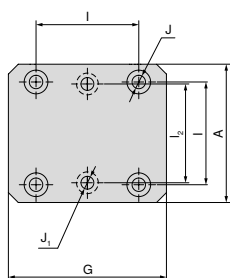

A	J ₁	J _{H7}	l _{2 ±0.01}	l _{±0.01}	G
mm	mm	mm	mm	mm	mm
70	6,5	12	50	52	80
70	6,5	12	50	52	100

ZSG mini – preglednica z merami za različne čeljusti

S hitrovpenjalnimi čeljustmi, prijemalne, 3 mm

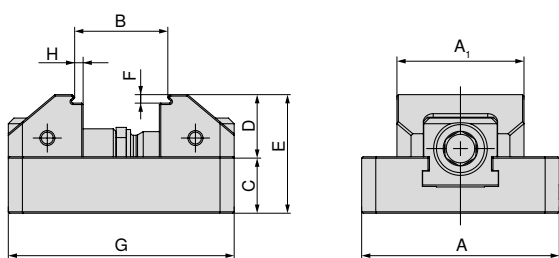

A mm	A ₁ mm	B mm	C mm	D mm	E mm	F mm	G mm	H mm	Katalogška št. Sistemske čeljusti
70	45	7 - 33	20	22	42	3	80	3	2 x 80 912 30100
70	70	7 - 33	20	22	42	3	80	3	2 x 80 912 30200
70	45	7 - 53	20	22	42	3	100	3	2 x 80 912 30100
70	70	7 - 53	20	22	42	3	100	3	2 x 80 912 30200

S hitrovpenjalno čeljustjo, gladka površina 5 mm

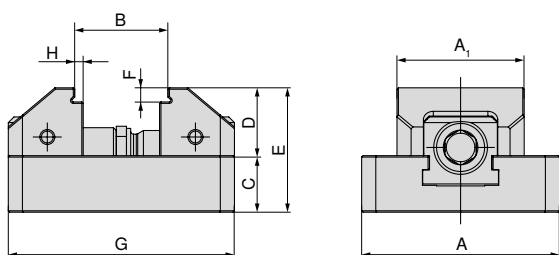

A mm	A ₁ mm	B mm	C mm	D mm	E mm	F mm	G mm	H mm	Katalogška št. Sistemske čeljusti
70	45	7 - 33	20	24	44	5	80	3	2 x 80 912 30300
70	70	7 - 33	20	24	44	5	80	3	2 x 80 912 30400
70	45	7 - 53	20	24	44	5	100	3	2 x 80 912 30300
70	70	7 - 53	20	24	44	5	100	3	2 x 80 912 30400

S hitrovpenjalno čeljustjo, mehka izvedba, jeklo

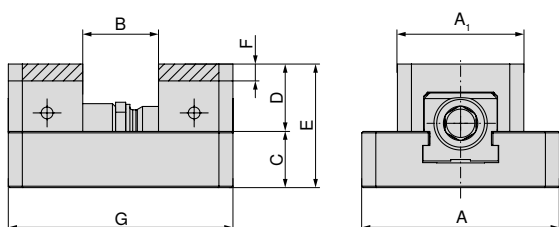

A mm	A ₁ mm	B mm	C mm	D mm	E mm	F mm	G mm	Katalogška št. Sistemske čeljusti
70	45	0 - 26	20	24	44	6	80	2 x 80 912 31000
70	70	0 - 26	20	24	44	6	80	2 x 80 912 31100
70	45	0 - 46	20	24	44	6	80	2 x 80 912 31000
70	70	0 - 46	20	24	44	6	80	2 x 80 912 31100

ZSG mini – preglednica z merami za različne čeljusti

Z reliefnim profilom hitrovpenjalne čeljusti

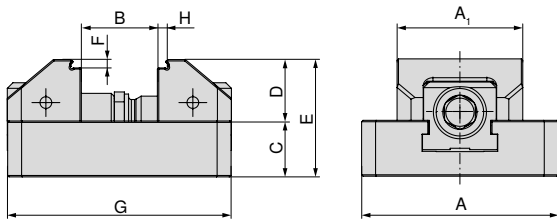

A mm	A ₁ mm	B mm	C mm	D mm	E mm	F mm	G mm	H mm	Katalogška št. Sistemske čeljusti
70	45	7 - 32	20	22	44	3	80	3	2 x 80 912 31200
70	70	7 - 32	20	22	44	3	80	3	2 x 80 912 31300
70	45	7 - 52	20	22	44	3	100	3	2 x 80 912 31200
70	70	7 - 52	20	22	44	3	100	3	2 x 80 912 31300

Z reliefnim profilom hitrovpenjalne čeljusti, povečano območje vpenjanja (VS)

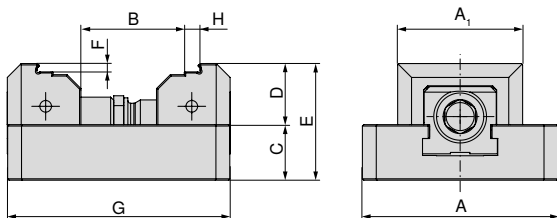

A mm	A ₁ mm	B mm	C mm	D mm	E mm	F mm	G mm	H mm	Katalogška št. Sistemske čeljusti
70	45	31 - 56	20	22	44	3	80	5	2 x 80 912 31400
70	70	31 - 56	20	22	44	3	80	5	2 x 80 912 31500
70	45	31 - 76	20	22	44	3	100	5	2 x 80 912 31400
70	70	31 - 76	20	22	44	3	100	5	2 x 80 912 31500

ZSG mini – preglednica z merami za različne čeljusti

S hitrovpenjalnimi čeljustmi, VS, prijemalne, 3 mm

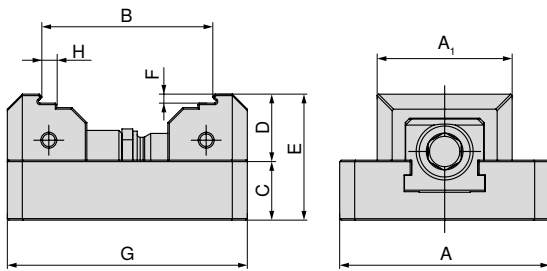

A mm	A ₁ mm	B mm	C mm	D mm	E mm	F mm	G mm	H mm	Kataloška št. Sistemske čeljusti
70	45	31 - 57	20	22	42	3	80	5	2 x 80 912 30500
70	70	31 - 57	20	22	42	3	80	5	2 x 80 912 30600
70	45	31 - 77	20	22	42	3	100	5	2 x 80 912 30500
70	70	31 - 77	20	22	42	3	100	5	2 x 80 912 30600

S hitrovpenjalno čeljustjo, povečano območje vpenjanja (VS), gladka, 5 mm

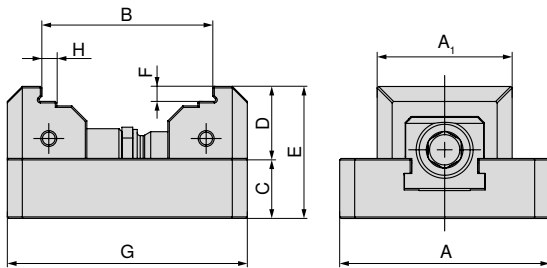

A mm	A ₁ mm	B mm	C mm	D mm	E mm	F mm	G mm	H mm	Kataloška št. Sistemske čeljusti
70	45	31 - 56	20	24	44	5	80	5	2 x 80 912 30700
70	70	31 - 56	20	24	44	5	80	5	2 x 80 912 30800
70	45	31 - 76	20	24	44	5	100	5	2 x 80 912 30700
70	70	31 - 76	20	24	44	5	100	5	2 x 80 912 30800

Pregled sistemov čeljusti

Hitrovpenjalne čeljusti, prijemalne, 3 mm

▲ Cena za kos

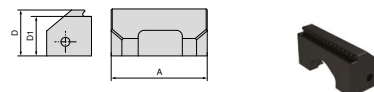

Za širino primeža	A	A ₁	D	D ₁	D ₂	E	M	M ₁	M ₂	EUR	Y4	NCG	H5G / -S / -Z	X5G-Z / -S	ESG 4	ESG 5	HDG 2	ZSG 4	ZSG mini	DSG 4	Verso	HSG	
70	45		22	19						50,80	80 912 30100												
70	70		22	19						66,90	80 912 30200									●			

Hitrovpenjalne čeljusti, gladke, 5 mm

▲ Cena za kos

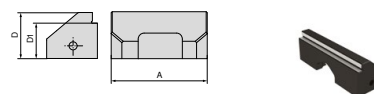

Za širino primeža	A	A ₁	D	D ₁	D ₂	E	M	M ₁	M ₂	EUR	Y4	NCG	H5G / -S / -Z	X5G-Z / -S	ESG 4	ESG 5	HDG 2	ZSG 4	ZSG mini	DSG 4	Verso	HSG	
70	45		24	19						61,50	80 912 30300												
70	70		24	19						77,80	80 912 30400									●			

Hitrovpenjalne čeljusti, VS, prijemalne, 3 mm

▲ Cena za kos

▲ VS = povečano območje vpenjanja

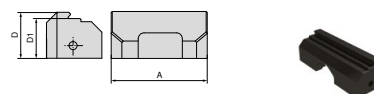

Za širino primeža	A	A ₁	D	D ₁	D ₂	E	M	M ₁	M ₂	EUR	Y4	NCG	H5G / -S / -Z	X5G-Z / -S	ESG 4	ESG 5	HDG 2	ZSG 4	ZSG mini	DSG 4	Verso	HSG	
70	45		22	19						50,80	80 912 30500												
70	70		22	19						66,90	80 912 30600									●			

Hitrovpenjalne čeljusti, VS, gladke, 5 mm

▲ Cena za kos

▲ VS = povečano območje vpenjanja

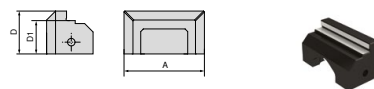

Za širino primeža	A	A ₁	D	D ₁	D ₂	E	M	M ₁	M ₂	EUR	Y4	NCG	H5G / -S / -Z	X5G-Z / -S	ESG 4	ESG 5	HDG 2	ZSG 4	ZSG mini	DSG 4	Verso	HSG	
70	45		24	19						61,50	80 912 30700												
70	70		24	19						77,80	80 912 30800									●			

Pregled sistemov čeljusti

Hitrovpenjalna čeljust, mehka izvedba, jeklo

- ▲ Material: 15NiCr13
- ▲ Cena za kos

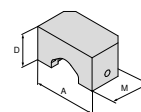

Za širino primeža	A	A ₁	D	D ₁	D ₂	E	M	M ₁	M ₂	EUR	Y4	NCG	H5G / -S / -Z	X5G-Z / -S	ESG 4	ESG 5	HDG 2	ZSG 4	ZSG mini	DSG 4	Verso	HSG	
70	45		24				26,5			41,00										●			
70	70		24				26,5			41,00										●			

Reliefni profil hitrovpenjalne čeljusti

- ▲ Cena za kos
- ▲ Primerna za LANG-ov predodtisnjeni reliefni profil

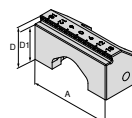

Za širino primeža	A	A ₁	D	D ₁	D ₂	E	M	M ₁	M ₂	EUR	Y4	NCG	H5G / -S / -Z	X5G-Z / -S	ESG 4	ESG 5	HDG 2	ZSG 4	ZSG mini	DSG 4	Verso	HSG	
70	45		22	19						77,80										●			
70	70		22	19						77,80										●			

Reliefni profil hitrovpenjalne čeljusti, VS

- ▲ Cena za kos
- ▲ primerna za LANG reliefni profil
- ▲ VS = povečano območje vpenjanja

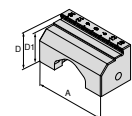

Za širino primeža	A	A ₁	D	D ₁	D ₂	E	M	M ₁	M ₂	EUR	Y4	NCG	H5G / -S / -Z	X5G-Z / -S	ESG 4	ESG 5	HDG 2	ZSG 4	ZSG mini	DSG 4	Verso	HSG	
70	45		22	19						95,00										●			
70	70		22	19						95,00										●			

Pregled pribora za sisteme

Natični nastavek

▲ Primerno za štirikotnik 3/8"

ESG 4	ZSG 4
ZSG mini	DSG 4
MSG 2	



Štirirobi	DRVS	80 875 ...
3/8"	mm	EUR
	11	Y4
		18,20 11100



→ Stran 176+180

Tukaj boste našli ustrezen „magnetni prislon obdelovanca“ in „momentni ključ“ (št. artikla 80 892 23800 in 80 884 402).

Imbus vijak

▲ Cena za kos

ZSG mini



G	80 912 ...
M6x25	EUR
	Y4
	1,20 50100

Cilindrični zatič

▲ Cena za kos

ZSG mini



D ₁ m6	M	80 912 ...
mm	mm	EUR
12	18	Y4
		2,30 50200

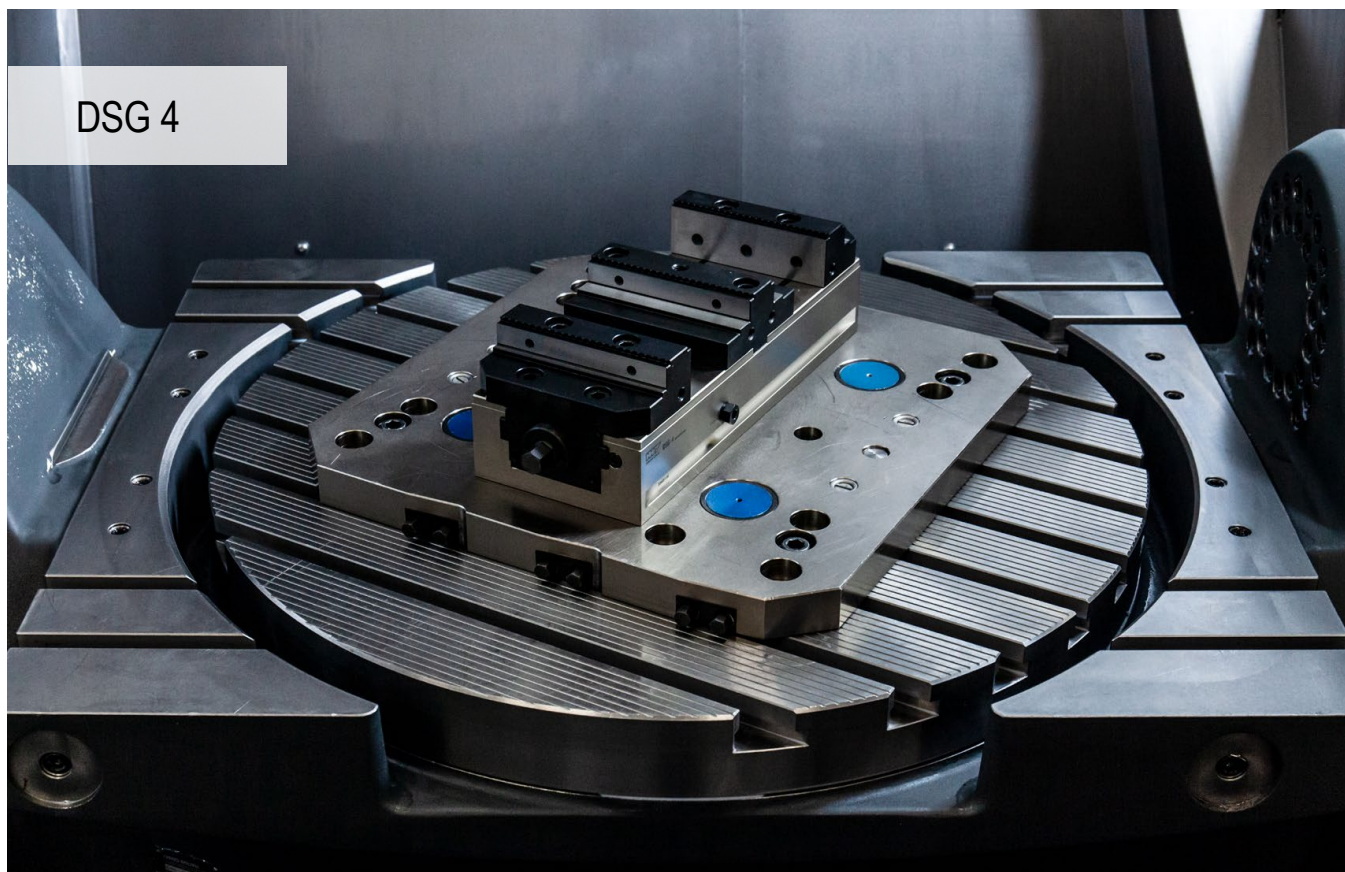

Visoka natančnost in visoka učinkovitost

Uporabniku prijazen vpenjalni sistem DSG 4 zagotavlja trajno visoko natančnost in širok spekter uporabe.

Prednosti za vas:

- ▲ Preprosta in stabilna funkcija tretje roke
- ▲ Preprosto in hitro pozicioniranje na vpenjalnem sistemu z ničelno točko MNG
- ▲ Velika vpenjalna sila od 5 do 40 kN z nizkim zateznim momentom
- ▲ Preprosta in hitra menjava čeljusti z 2 vijakoma
- ▲ Obsežen program modularnih čeljusti

Vpenjanje/usmerjanje:

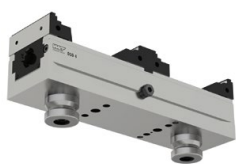

Pritrditev z vpenjalnim sistemom z ničelno točko MNG (2-3 vpenjalni čepi)



Pritrditev skozi osnovno telo s štirimi vijaki M8

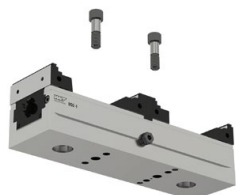

Pritrditev skozi osnovno telo z dvema vijakoma za namestitvev **Kataloška št. 80 895 019**



Pritrditev s 4-6 vpenjalnimi sponami **Kataloška št. 80 890 315**

Vpenjalna sila:

Zatezni moment / vpenjalna sila DSG 4 – 80 mm

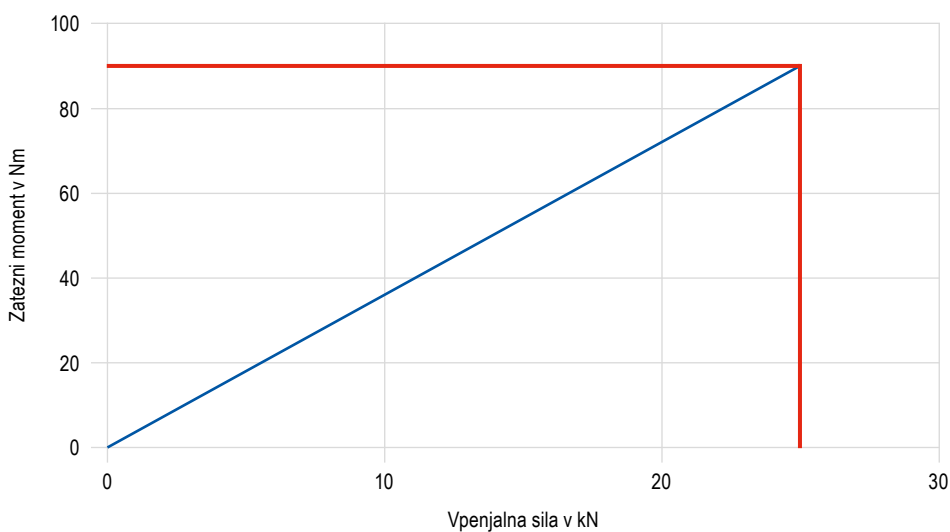

Zatezni moment / vpenjalna sila DSG 4 – 125 mm

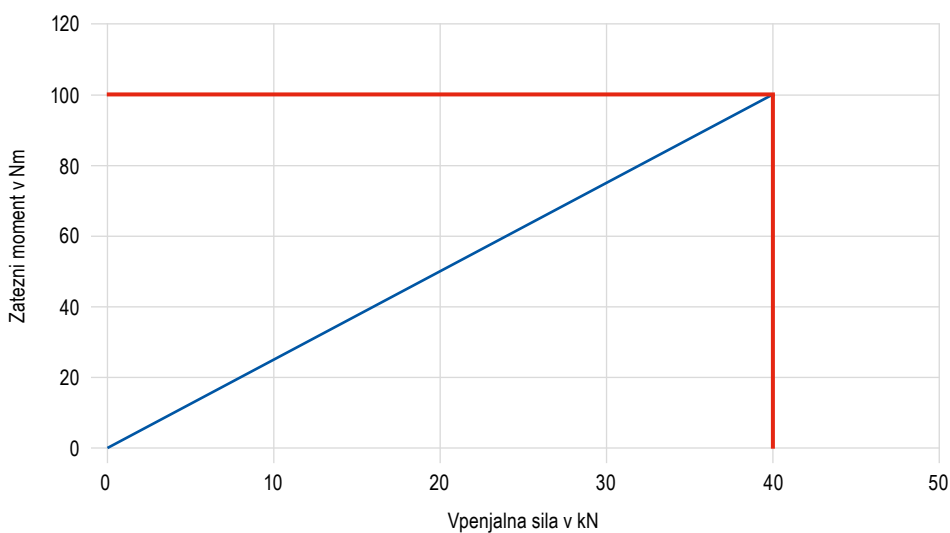

Upravljanje tretje roke

Funkcija upravljanja tretje roke za DSG 4 je zagotovljena s premikom zadnjega drsnika s pomočjo tlačnih vzmeti.



Stranski vpenjalni vijak A ni zategnjen, ampak sproščen za pribl. 1/2 obrata. Pri popolnoma odprtemu primeži morate pomične vpenjalne čeljusti B in C glede na velikost obdelovanca namestiti in jih pritrditi na ustrezne utore na drsnikih D in E. Prav tako je mogoče vpeti 2 različno velika obdelovanca.

Predelava na enojni primež



Z navojnim zatičem z notranjim šesterorobom je mogoče blokirati zadnji drsnik in se lahko DSG 4 uporablja tudi kot enojni primež. **Pomembna opomba:** Ni primeren za uporabo več enojnih primežev eden poleg drugega. Pri tem priporočamo modifikacijo z dodatnim prečnim utorom v osnovnem telesu in za to primerno fiksno čeljustjo.

PolyClamp – DSG 4

- ▲ Dvojni primež brez čeljusti
- ▲ 100-% oklopljen
- ▲ Hitra odstranitev in namestitvev
- ▲ Prilagodljiv vpenjalni sistem

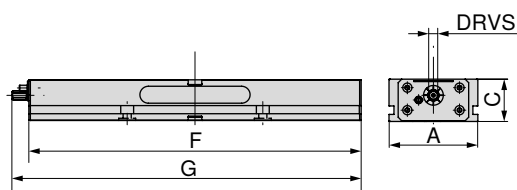
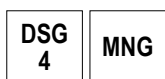

								80 906 ...	
								EUR	
								Y4	
A	C	F	G	TQX	DRVS	MXC	WT		
mm	mm	mm	mm	Nm	mm	kN	kg		
80	55	300	308	90	12	0 - 25	8	1.560,00	080
125	60	320	347	100	14	0 - 40	14	1.850,00	125
125	60	390	417	100	14	0 - 40	17	2.040,00	12700
125	60	460	487	100	14	0 - 40	20	2.300,00	12800
125	60	530	557	100	14	0 - 40	24	2.510,00	12900
125	60	600	627	100	14	0 - 40	27	2.720,00	13000
125	60	670	697	100	14	0 - 40	30	2.840,00	13100
125	60	740	767	100	14	0 - 40	34	2.950,00	126

Vodnik po primežih

Preglednice z merami za različne čeljusti	105-107	Pribor za sisteme	108+110
Upravljanje tretje roke	102	Predelava na enojni primež	103
Vpenjalni sistem z ničelno točko MNG/PNG	134-163	Splošni pribor	164-183

Mere spodnje strani za DSG 4

Širina osnovnega telesa 80 mm
in dolžina 300 mm

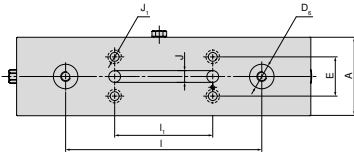

A	D ₆ H6	E ±0.015	I ±0.01	I ₁ ±0.01	J H7	J ₁
mm	mm	mm	mm	mm	mm	mm
80	25	40	200	100	12	9

Širina osnovnega telesa 125 mm
in dolžina 460 mm, 530 mm

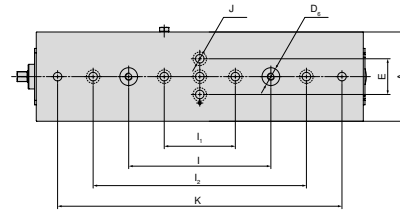

A	D ₆ H6	E ±0.015	I ±0.01	I ₁ ±0.01	I ₂ ±0.002	J H7	K ±0.002
mm	mm	mm	mm	mm	mm	mm	mm
125	25	50	200	100	300	12	400
125	25	50	200	100	300	12	500

Širina osnovnega telesa 125 mm
in dolžina 320 mm

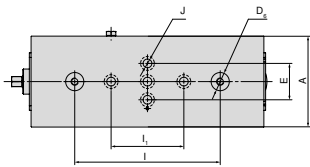

A	D ₆ H6	E ±0.015	I ±0.01	I ₁ ±0.01	J H7
mm	mm	mm	mm	mm	mm
125	25	50	200	100	12

Širina osnovnega telesa 125 mm
in dolžina 600 mm

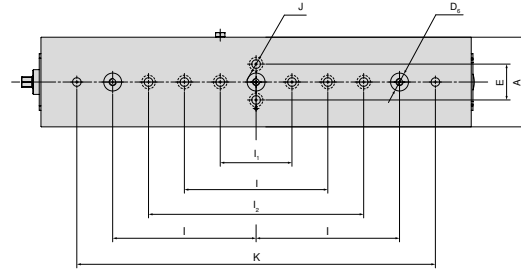

A	D ₆ H6	E ±0.015	I ±0.01	I ₁ ±0.01	I ₂ ±0.002	J H7	K ±0.002
mm	mm	mm	mm	mm	mm	mm	mm
125	25	50	200	100	300	12	500

Širina osnovnega telesa 125 mm
in dolžina 390 mm

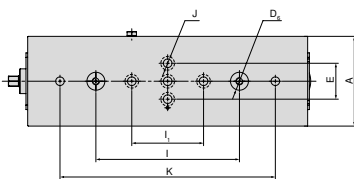

A	D ₆ H6	E ±0.015	I ±0.01	I ₁ ±0.01	J H7	K ±0.002
mm	mm	mm	mm	mm	mm	mm
125	25	50	200	100	12	300

Širina osnovnega telesa 125 mm
in dolžina 670 mm, 740 mm

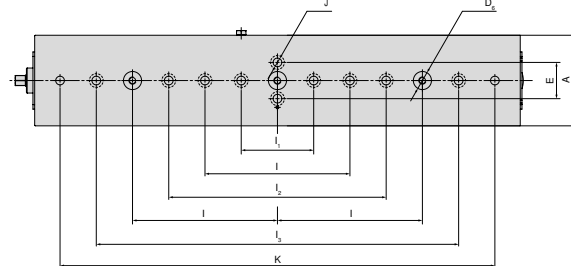

A	D ₆ H6	E ±0.015	I ±0.01	I ₁ ±0.01	I ₂ ±0.002	I ₃ ±0.025	J H7	K ±0.002
mm	mm	mm	mm	mm	mm	mm	mm	mm
125	25	50	200	100	300	500	12	600
125	25	50	200	100	300	500	12	700

Preglednica z merami DSG 4 za različne čeljusti

S prijemalnimi obrnljivimi čeljustmi in sredinsko prijemalno čeljustjo

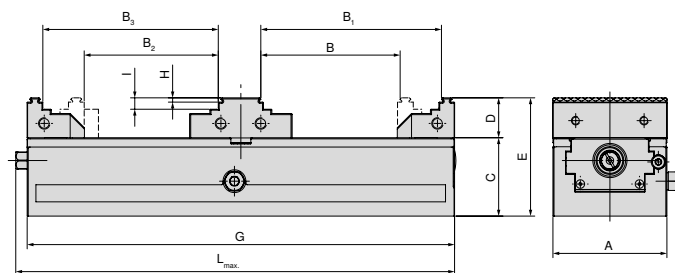

A mm	B mm	B ₁ mm	B ₂ mm	B ₃ mm	C mm	D mm	E mm	G mm	H mm	I mm	L _{max} mm	Kataloška št. Sistemske čeljusti
80	25 - 97	54 - 126	31 - 93	51 - 122	55	28	83	300	3	8	308	2 x 80 878 810 + 80 906 300
125	40 - 86	75 - 121	42 - 79	68 - 114	60	40	100	320	3	18	347	2 x 80 901 303 + 80 906 304
125	40 - 121	75 - 156	42 - 114	68 - 149	60	40	100	390	3	18	417	2 x 80 901 303 + 80 906 304
125	40 - 156	75 - 191	42 - 149	68 - 184	60	40	100	460	3	18	487	2 x 80 901 303 + 80 906 304
125	40 - 191	75 - 226	42 - 184	68 - 219	60	40	100	530	3	18	557	2 x 80 901 303 + 80 906 304
125	40 - 226	75 - 261	42 - 219	68 - 254	60	40	100	600	3	18	627	2 x 80 901 303 + 80 906 304
125	40 - 261	75 - 296	42 - 254	68 - 289	60	40	100	670	3	18	697	2 x 80 901 303 + 80 906 304
125	40 - 296	75 - 331	42 - 289	68 - 324	60	40	100	740	3	18	767	2 x 80 901 303 + 80 906 304

S prijemalnimi obrnljivimi čeljustmi in gladko sredinsko čeljustjo

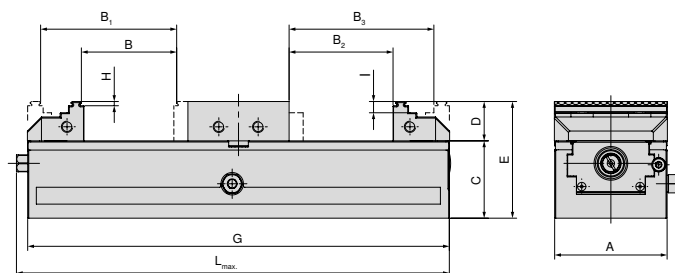

A mm	B mm	B ₁ mm	B ₂ mm	B ₃ mm	C mm	D mm	E mm	G mm	H mm	I mm	L _{max} mm	Kataloška št. Sistemske čeljusti
80	5 - 67	34 - 96	0 - 73	40 - 102	55	28	83	300	3	8	308	2 x 80 878 810 + 80 906 301
125	7 - 44	42 - 77	0 - 47	46 - 82	60	40	100	320	3	18	347	2 x 80 901 303 + 80 906 305
125	7 - 79	42 - 112	0 - 82	46 - 117	60	40	100	390	3	18	417	2 x 80 901 303 + 80 906 305
125	7 - 114	42 - 149	0 - 117	46 - 152	60	40	100	460	3	18	487	2 x 80 901 303 + 80 906 305
125	7 - 147	42 - 182	0 - 152	46 - 187	60	40	100	530	3	18	557	2 x 80 901 303 + 80 906 305
125	7 - 184	42 - 217	0 - 187	46 - 222	60	40	100	600	3	18	627	2 x 80 901 303 + 80 906 305
125	7 - 219	42 - 252	0 - 222	46 - 257	60	40	100	670	3	18	697	2 x 80 901 303 + 80 906 305
125	7 - 254	42 - 287	0 - 257	46 - 292	60	40	100	740	3	18	767	2 x 80 901 303 + 80 906 305

Preglednica z merami DSG 4 za različne čeljusti

Z blok čeljustmi in gladko sredinsko čeljustjo

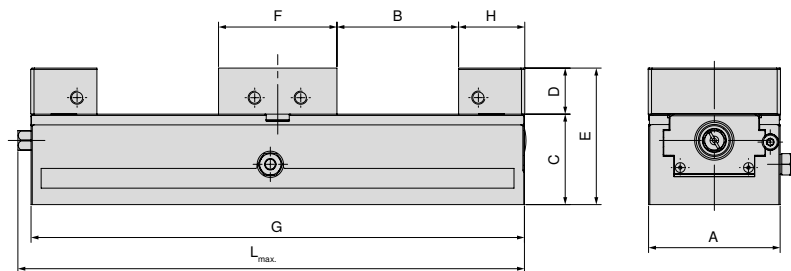

A mm	B mm	C mm	D mm	E mm	F mm	G mm	H mm	L _{max} mm	Kataloška št. Sistemske čeljusti
80	0 - 73	55	28	83	72	300	40	308	2 x 80 901 31300 + 80 906 301
125	0 - 46	60	40	100	98	320	66	347	2 x 80 901 31500 + 80 906 305
125	0 - 81	60	40	100	98	390	66	417	2 x 80 901 31500 + 80 906 305
125	0 - 116	60	40	100	98	460	66	487	2 x 80 901 31500 + 80 906 305
125	0 - 151	60	40	100	98	530	66	557	2 x 80 901 31500 + 80 906 305
125	0 - 186	60	40	100	98	600	66	627	2 x 80 901 31500 + 80 906 305
125	0 - 221	60	40	100	98	670	66	697	2 x 80 901 31500 + 80 906 305
125	0 - 256	60	40	100	98	740	66	767	2 x 80 901 31500 + 80 906 305

Z vrtljivo in adaptersko ploščo

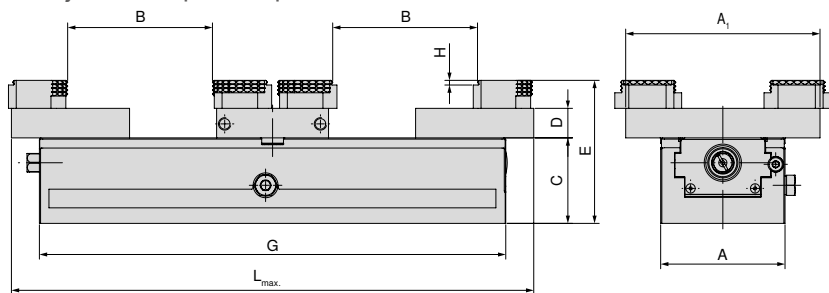

A mm	A ₁ mm	B mm	C mm	D mm	E mm	G mm	H mm	L _{max} mm	Kataloška št. Sistemske čeljusti
80	125	0 - 92	55	19	92	300	3	308	2 x 80 878 870 + 80 906 303
125	180	7 - 92	60	22	100	320	3	365	2 x 80 878 570 + 80 906 307
125	180	7 - 133	60	22	100	390	3	435	2 x 80 878 570 + 80 906 307
125	180	7 - 168	60	22	100	460	3	505	2 x 80 878 570 + 80 906 307
125	180	7 - 203	60	22	100	530	3	575	2 x 80 878 570 + 80 906 307
125	180	7 - 238	60	22	100	600	3	645	2 x 80 878 570 + 80 906 307
125	180	7 - 273	60	22	100	670	3	715	2 x 80 878 570 + 80 906 307
125	180	7 - 308	60	22	100	740	3	785	2 x 80 878 570 + 80 906 307

Preglednica z merami DSG 4 za različne čeljusti

Z aluminijastimi čeljustmi in aluminijasto sredinsko čeljustjo

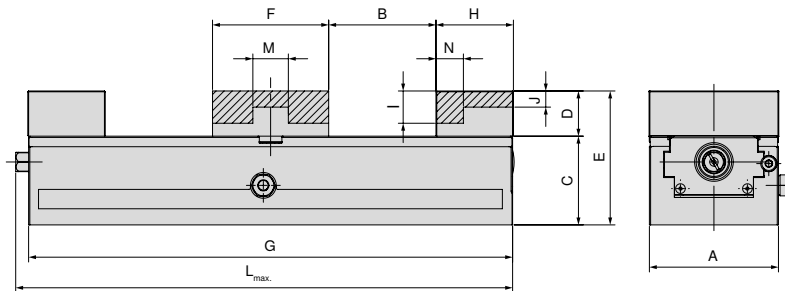

A mm	B mm	C mm	D mm	E mm	F mm	G mm	H mm	I mm	J mm	L _{max} mm	M mm	N mm	Katalogška št. Sistemske čeljusti
80	0 - 66	55	28	83	72	300	40	20	10	308	22	17	2 x 80 878 850 + 80 906 302
125	0 - 42	60	40	100	98	320	68		17	347	38	28	2 x 80 878 550 + 80 906 306
125	0 - 77	60	40	100	98	390	68		17	417	38	28	2 x 80 878 550 + 80 906 306
125	0 - 112	60	40	100	98	460	68		17	487	38	28	2 x 80 878 550 + 80 906 306
125	0 - 147	60	40	100	98	530	68		17	557	38	28	2 x 80 878 550 + 80 906 306
125	0 - 182	60	40	100	98	600	68		17	627	38	28	2 x 80 878 550 + 80 906 306
125	0 - 217	60	40	100	98	670	68		17	697	38	28	2 x 80 878 550 + 80 906 306
125	0 - 252	60	40	100	98	740	68		17	767	38	28	2 x 80 878 550 + 80 906 306

Pregled sistemov čeljusti

Obrnljiva čeljust, prijemalna, stopnja 3 mm, pomična

▲ Cena za kos

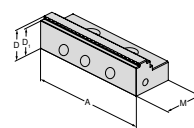

Za širino primeža	A	A ₁	D	D ₁	D ₂	E	M	M ₁	M ₂	EUR	Y4	NCG	H5G / -S / -Z	X5G-Z / -S	ESG 4	ESG 5	HDG 2	ZSG 4	ZSG mini	DSG 4	Verso	HSG		
125	125		40	37			66			224,00					●	●				●				
											80 901 303													

Obrnljiva čeljust, prijemalna, stopnja 3 mm, pomična

▲ Cena za kos

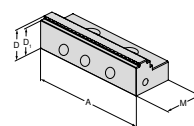

Za širino primeža	A	A ₁	D	D ₁	D ₂	E	M	M ₁	M ₂	EUR	Y4	NCG	H5G / -S / -Z	X5G-Z / -S	ESG 4	ESG 5	HDG 2	ZSG 4	ZSG mini	DSG 4	Verso	HSG		
80	80		28	25			40			135,00					●	●		●		●				
											80 878 810													

Sredinska čeljust, prijemalna, stopnja 3 mm

▲ Cena za kos

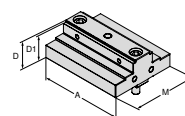

Za širino primeža	A	A ₁	D	D ₁	D ₂	E	M	M ₁	M ₂	EUR	Y4	NCG	H5G / -S / -Z	X5G-Z / -S	ESG 4	ESG 5	HDG 2	ZSG 4	ZSG mini	DSG 4	Verso	HSG	
80	80		28	25			72			278,00											●		
125	125		40	37			98			370,00											●		
											80 906 300												
											80 906 304												

Sredinska čeljust, gladka

▲ Cena za kos

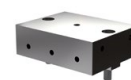
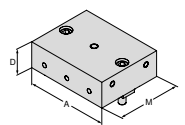

Za širino primeža	A	A ₁	D	D ₁	D ₂	E	M	M ₁	M ₂	EUR	Y4	NCG	H5G / -S / -Z	X5G-Z / -S	ESG 4	ESG 5	HDG 2	ZSG 4	ZSG mini	DSG 4	Verso	HSG
80	80		28				72			214,00											●	
125	125		40				98			317,00											●	
											80 906 301											
											80 906 305											

Pregled sistemov čeljusti

Aluminijasta čeljust, pomična

- ▲ Za proizvodnjo oblikovnih čeljusti
- ▲ Cena za kos

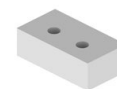
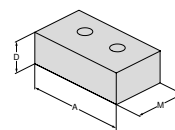

Za širino primeža	A	A ₁	D	D ₁	D ₂	E	M	M ₁	M ₂	EUR	Y4	NCG	H5G / -S / -Z	X5G-Z / -S	ESG 4	ESG 5	HDG 2	ZSG 4	ZSG mini	DSG 4	Verso	HSG	
80	80		28				48			86,40	80 878 850				●	●		●		●			
125	125		40				68			98,30	80 878 550				●						●		

Sredinska čeljust, aluminijasta

- ▲ Za proizvodnjo oblikovnih čeljusti
- ▲ Cena za kos

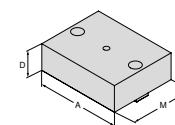

Za širino primeža	A	A ₁	D	D ₁	D ₂	E	M	M ₁	M ₂	EUR	Y4	NCG	H5G / -S / -Z	X5G-Z / -S	ESG 4	ESG 5	HDG 2	ZSG 4	ZSG mini	DSG 4	Verso	HSG	
80	80		28				72			77,80	80 906 302										●		
125	125		40				98			105,00	80 906 306										●		

Bločna čeljust, pomična

- ▲ Cena za kos

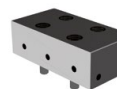
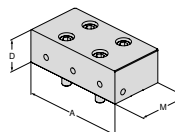

Za širino primeža	A	A ₁	D	D ₁	D ₂	E	M	M ₁	M ₂	EUR	Y4	NCG	H5G / -S / -Z	X5G-Z / -S	ESG 4	ESG 5	HDG 2	ZSG 4	ZSG mini	DSG 4	Verso	HSG	
80	80		28				40			244,00	80 901 31300				●	●		●		●			
125	125		40				66			342,00	80 901 31500				●						●		

Vrtljiva čeljust, pomična

- ▲ Za vpenjanje 6-delnih obrnljivih čeljusti
- ▲ Cena za kos

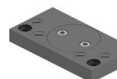
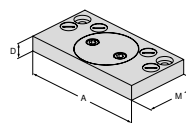

Za širino primeža	A	A ₁	D	D ₁	D ₂	E	M	M ₁	M ₂	EUR	Y4	NCG	H5G / -S / -Z	X5G-Z / -S	ESG 4	ESG 5	HDG 2	ZSG 4	ZSG mini	DSG 4	Verso	HSG	
80	125		19				76			409,00	80 878 870				●						●		
125	180		22				95			426,00	80 878 570				●			●		●			

Pregled sistemov čeljusti

Sredinska čeljust adapterske plošče, nepomična

- ▲ Za vpenjanje 6-delnih obrnljivih čeljusti
- ▲ Cena za kos

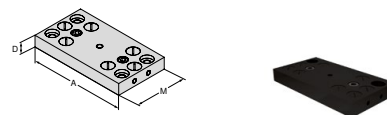

Za širino primeža	A	A ₁	D	D ₁	D ₂	E	M	M ₁	M ₂	EUR	Y4	NCG	H5G / -S / -Z	X5G-Z / -S	ESG 4	ESG 5	HGG 2	ZSG 4	ZSG mini	DSG 4	Verso	HSG	
80	125		19				72			291,00													
125	180		22				98			346,00													

6-delni čeljustni nastavek

- ▲ 1 = Gladka, prevlečena z volframovim karbidom
- ▲ 2 = Prijemalo s stopnico 3 mm
- ▲ 3 = Prijemalo s stopnico 8 mm
- ▲ 4 = Prijemalo s stopnico 18 mm
- ▲ 5 = Prijemalo, okroglo, s stopnico 8 mm
- ▲ 6 = Prijemalo, okroglo
- ▲ M_{najv.} = 60 Nm
- ▲ Vklj. s pritrdilnimi vijaki

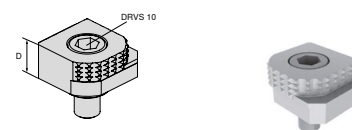

Za širino primeža	A	A ₁	D	D ₁	D ₂	E	M	M ₁	M ₂	EUR	Y4	NCG	H5G / -S / -Z	X5G-Z / -S	ESG 4	ESG 5	HGG 2	ZSG 4	ZSG mini	DSG 4	Verso	HSG	
			18							80,60													

6-delni čeljustni nastavek, s prijemalom iz karbidne trdine

- ▲ 1 = gladka
- ▲ 2 = karbidno prijemalo
- ▲ 3 = karbidno prijemalo s stopnico 3 mm
- ▲ 4 = karbidno prijemalo s stopnico 8 mm
- ▲ 5 = karbidno prijemalo, okroglo, s stopnico 8 mm
- ▲ 6 = karbidno prijemalo, okroglo
- ▲ vklj. s pritrdilnimi vijaki

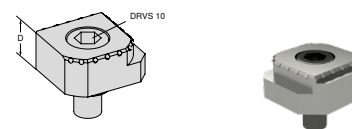

Za širino primeža	A	A ₁	D	D ₁	D ₂	E	M	M ₁	M ₂	EUR	Y4	NCG	H5G / -S / -Z	X5G-Z / -S	ESG 4	ESG 5	HGG 2	ZSG 4	ZSG mini	DSG 4	Verso	HSG	
			18							117,00													

Pregled pribora za sisteme

Plastični mašilni čep

DSG
4



G	80 906 ...
M10x12	EUR Y4 1,20 500

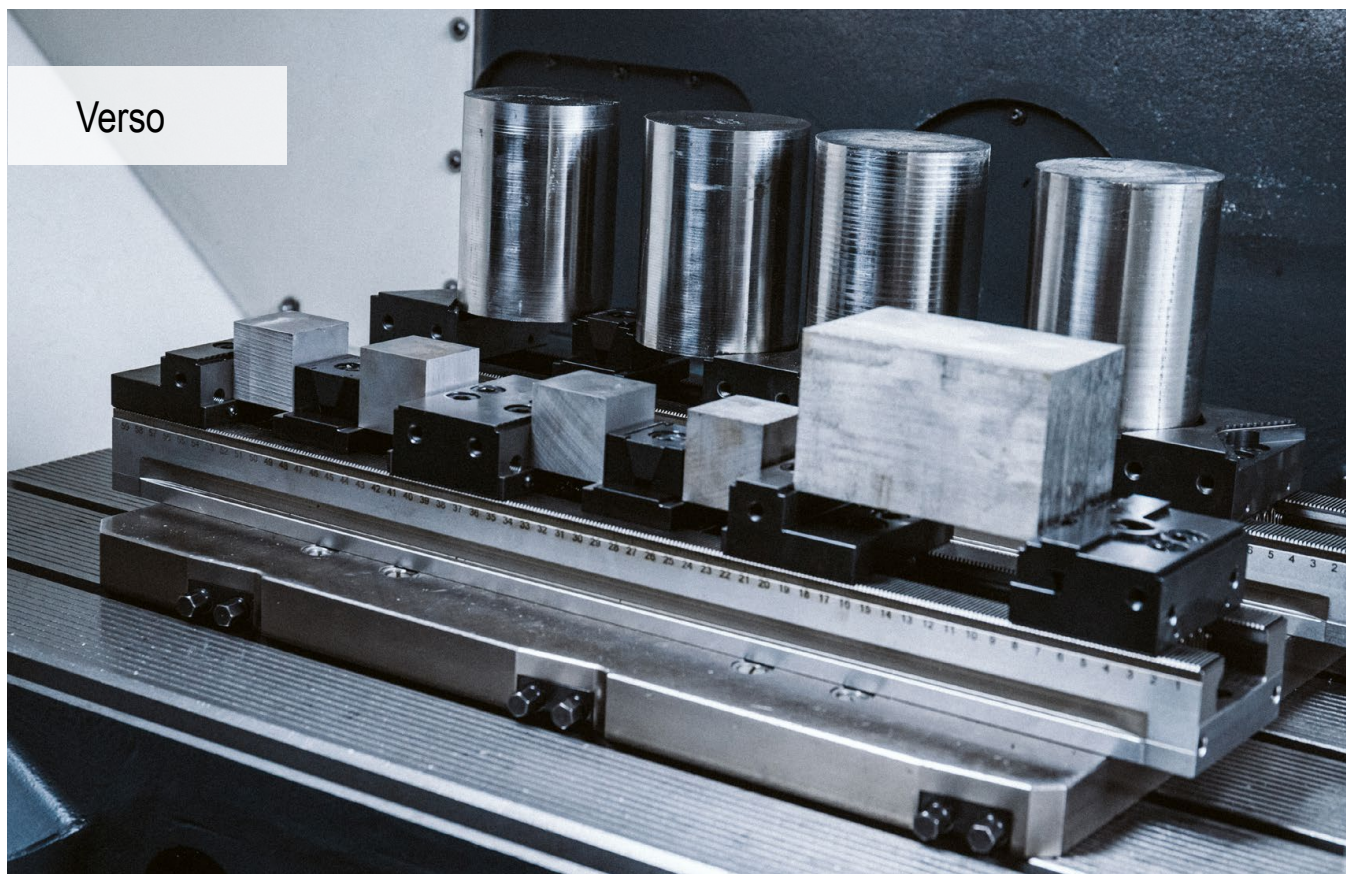

Verso

Večnamensko orodje za vpetje obdelovancev

Z novim večkratnim primežem je mogoče številne manjše in večje obdelovance brez težav vpeti na 3-, 4- ali 5-osni stroj. Zaradi še vitkejših čeljusti je debelina obdelovancev še večja.

Prednosti za vas:

- ▲ kaljeno in brušeno ozobljenje zagotavlja najvišjo natančnost in dimenzijsko stabilnost
- ▲ sistem hitre menjave čeljusti za nepomične in nastavljive čeljusti
- ▲ celovit modularni program za vse vrste obdelovalnih centrov
- ▲ Večkratno vpenjanje s klinastimi vpenjalnimi elementi
- ▲ obsežen program modularnih čeljusti
- ▲ preprost podaljšek vpenjalne tirnice s priključnim elementom



Vpenjanje/usmerjanje:

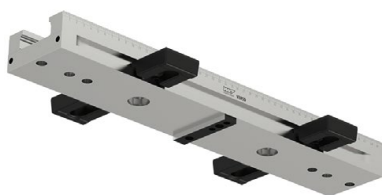

Prek T-utorov ali vijakov
Izravnava v T-utoru (14, 16, 18 mm) z ustreznim kompletom za izravnavo v T-utorih. Za T-utor 12 mm: Uporabite dva valjasta zatiča premera 12 mm.



Z vpenjalno spono
Izravnava in vpenjanje z bočno nameščenimi vpenjalnimi sponami.



Prek rastrskih izvrtin
Določanje položaja in pritrditev z dvema velikostnima vložkoma s premerom 12f7/M12 v prvo in zadnjo izvrtino vpenjalne tirnice. Dodatno privitje s cilindričnimi vijaki M12 skozi preostale izvrtine.

Vpenjanje/usmerjanje:



Z vpenjalnim sistemom z ničelno točko
Vpenjalna tirnica je opremljena z vpenjalnimi mesti MNG,
ki omogočajo pritrditve vpenjalnih čepov MNG
(do dolžine osnovnega telesa 500 mm = 2 oz. od 600 mm = 3 vpenjalni čepi).

Vpenjalna sila:

Zatezni vrtilni moment/vpenjalna sila večkratnega primeža Verso

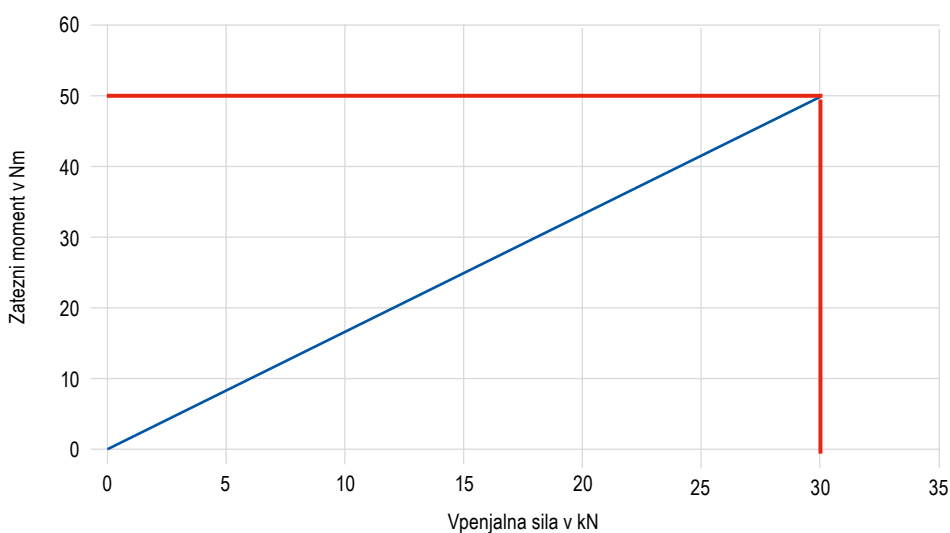

Sistem za hitro menjavo čeljusti za nepomične in nastavljive čeljusti

Večkratni primež Verso je standardno opremljen s sistemom za hitro menjavo čeljusti. Nepomične in nastavljive čeljusti lahko razrahljate, odstranite ali premikate z uporabo dveh vijakov. Čeljust lahko odstranite v smeri navzgor. Tako je mogoče vsako čeljust odstraniti posebej, ne da bi bilo treba demontirati tudi drugo. Čas opremljanja se tako močno skrajša.



Odvijte vijakov



snemite in uporabite



Zategnitev vijakov

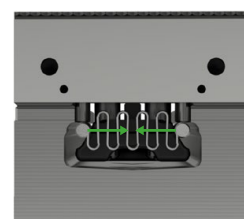

Položaj za odpenjanje

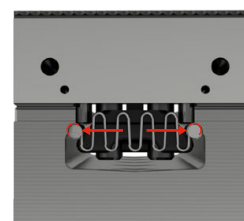

Položaj za vpenjanje

Sistem za hitro menjavo vpenjalnih čeljusti

Nepomične in nastavljive čeljusti sistema večkratnega primeža Verso so standardno opremljene s sistemom za hitro menjavo čeljusti. Vpenjalno čeljust je mogoče razrahljati in zamenjati z uporabo dveh vijakov. Tako je mogoča hitra menjava čeljusti.



Priključitev vpenjalnih tirnic

S priključnim elementom je mogoče med seboj povezati oziroma podaljšati dve ali več vpenjalnih tirnic večkratnega primeža Verso.

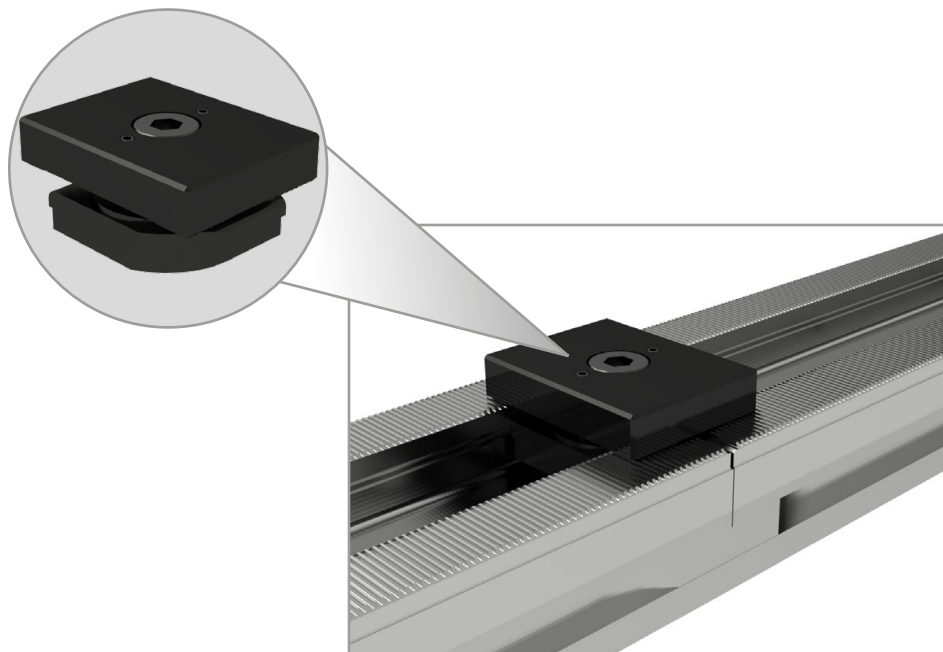

PolyClamp – Verso

- ▲ Uporaba pri preprostem in večkratnem vpenjanju
- ▲ Večkratno vpenjanje s klinastimi vpenjalnimi elementi
- ▲ Obdelovance je mogoče vpeti na 3-, 4- ali 5-osne stroje
- ▲ Primerno tudi za vpenjanje na MNG z adapterskimi ploščami

Obseg dobave:

Osnovno telo brez čeljusti

Verso

MMG

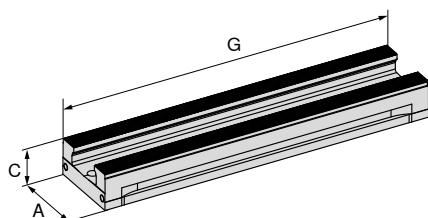

NEW

80 914 ...

EUR
Y4

A mm	C mm	G mm	MXC kN	WT kg	
90	45	260	0 - 50	5,0	804,00 09000
90	45	400	0 - 50	7,7	1.060,00 09100
90	45	500	0 - 50	9,6	1.280,00 09200
90	45	600	0 - 50	11,5	1.540,00 09300
90	45	650	0 - 50	12,5	1.640,00 09400

Verso – preglednica z merami

Vpenjalna tirnica

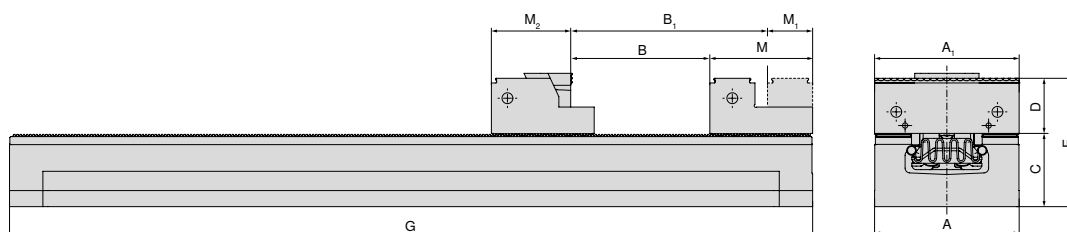

A mm	A ₁ mm	B mm	B ₁ mm	C mm	D mm	E mm	G mm	M mm	M ₁ mm	M ₂ mm
90	40 / 65 / 90	145	181	45	35	80	260	64	28	53,5
90	40 / 65 / 90	285	321	45	35	80	400	64	28	53,5
90	40 / 65 / 90	385	421	45	35	80	500	64	28	53,5
90	40 / 65 / 90	485	521	45	35	80	600	64	28	53,5
90	40 / 65 / 90	535	571	45	35	80	650	64	28	53,5



Pri uporabi nihajoče prijemalne čeljusti 90 mm in vzporednih prijemalnih čeljusti dimenzije B, B₁ in M₂ odstopajo.

Vodnik po primežih

Mere spodnje strani

115

Pregled območij vpenjanja

116

Pribor za sisteme

117–124

Splošni pribor

164–183

Mere spodnje strani večkratnega primeža Verso

Širina osnovnega telesa 90 mm
in dolžina 260 mm

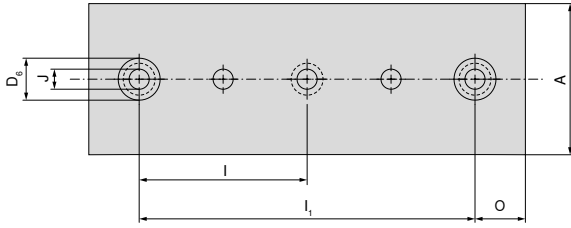

A	D ₆ H7	I _{±0,015}	I _{1±0,015}	J _{F7}	O _{±0,015}
mm	mm	mm	mm	mm	mm
90	25	100	200	12	30

Širina osnovnega telesa 90 mm
in dolžina 600 mm

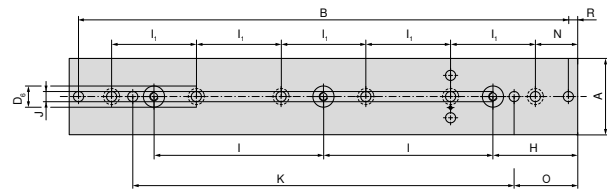

A	B	D ₆ H7	H _{±0,015}	I _{±0,015}	I _{1±0,015}	J _{F7}	K _{±0,015}	N	O _{±0,015}	R
mm	mm	mm	mm	mm	mm	mm	mm	mm	mm	mm
90	578	25	100	200	100	12	450	50	75	11

Širina osnovnega telesa 90 mm
in dolžina 400 mm

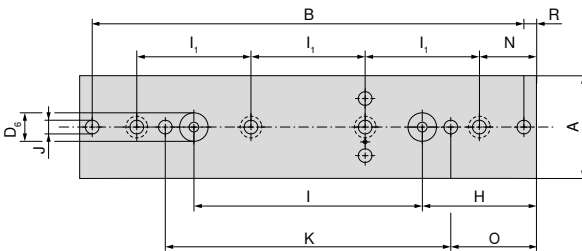

A	B	D ₆ H7	H _{±0,015}	I _{±0,015}	I _{1±0,015}	J _{F7}	K _{±0,015}	N	O _{±0,015}	R
mm	mm	mm	mm	mm	mm	mm	mm	mm	mm	mm
90	378	25	100	200	100	12	250	50	75	11

Širina osnovnega telesa 90 mm
in dolžina 650 mm

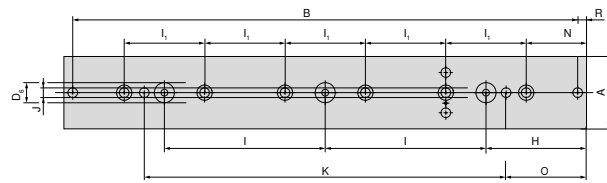

A	B	D ₆ H7	H _{±0,015}	I _{±0,015}	I _{1±0,015}	J _{F7}	K _{±0,015}	N	O _{±0,015}	R
mm	mm	mm	mm	mm	mm	mm	mm	mm	mm	mm
90	628	25	125	200	100	12	450	75	100	11

Širina osnovnega telesa 90 mm
in dolžina 500 mm

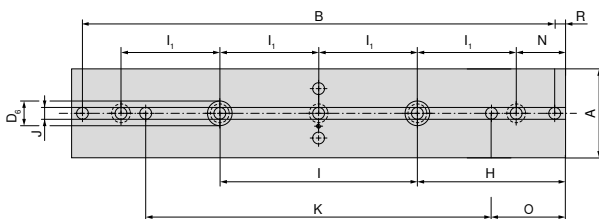

A	B	D ₆ H7	H _{±0,015}	I _{±0,015}	I _{1±0,015}	J _{F7}	K _{±0,015}	N	O _{±0,015}	R
mm	mm	mm	mm	mm	mm	mm	mm	mm	mm	mm
90	478	25	150	200	100	12	350	50	75	11

Pregled območja vpenjanja večkratnega primeža Verso

Širina vpenjanja prikazuje največjo velikost obdelovanca glede na število vpenjalnih mest za posamezne dolžine vpenjalnih tirnic.

Nastavljive čeljusti s čeljustjo z vlekem navzdol, prijemalne, 40 mm

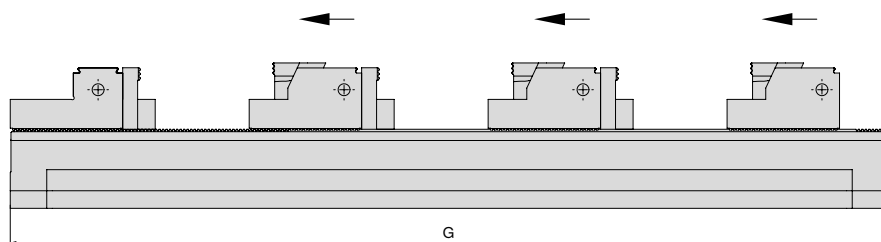

G mm	Število obdelovancev							Kataloška št. Primež
	1	2	3	4	5	6	7	
260	134	36	–	–	–	–	–	80 914 09000
400	274	106	50	22	–	–	–	80 914 09100
500	374	156	82	45	24	–	–	80 914 09200
600	474	206	116	72	44	26	–	80 914 09300
650	524	230	135	84	54	34	20	80 914 09400

Nastavljive čeljusti z vzporednimi vpenjalnimi čeljustmi

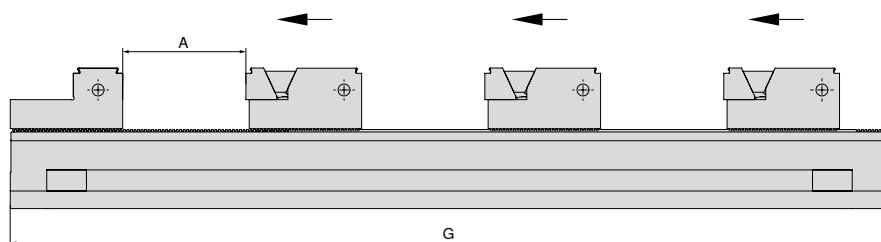

G mm	Število obdelovancev									Kataloška št. Primež
	1 A	2 A	3 A	4 A	5 A	6 A	7 A	8 A	9 A	
260	175	59	–	–	–	–	–	–	–	80 914 09000
400	315	129	67	27	10	–	–	–	–	80 914 09100
500	415	179	100	61	30	15	–	–	–	80 914 09200
600	515	229	133	86	57	32	19	10	–	80 914 09300
650	565	254	150	98	67	46	26	16	8	80 914 09400

S klinastimi vpenjalnimi elementi

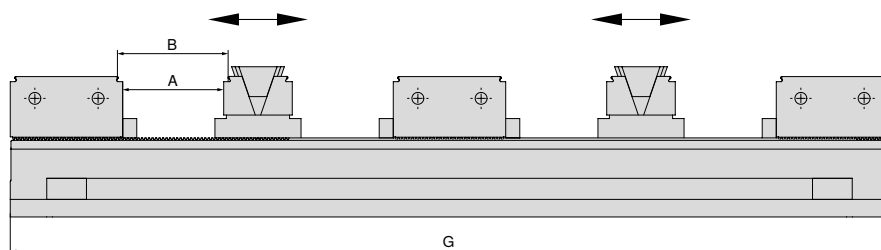

G mm	Število obdelovancev								Kataloška št. Primež
	2		4		6		8		
	A	B	A	B	A	B	A	B	
260	45	50	–	–	–	–	–	–	80 914 09000
400	115	120	31	36	–	–	–	–	80 914 09100
500	165	170	56	61	19	24	–	–	80 914 09200
600	215	220	81	86	36	41	14	19	80 914 09300
650	240	245	93	98	44	49	20	25	80 914 09400

Pregled sistemov čeljusti

Čeljust na prislonu, nepomična, stopnja 2,9 mm

▲ Cena za kos

Za širino primeža	A	A ₁	D	D ₁	D ₂	E	M	M ₁	M ₂
90	90		32	34,9			64		

EUR 342,00

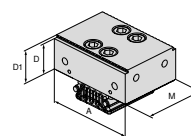

NEW

Y4	NCG	H5G / -S / -Z	X5G-Z / -S	ESG 4	ESG 5	HDG 2	ZSG 4	ZSG mini	DSG 4	Versto	HSG
80 914 31800										●	

Obrnljiva čeljust, nepomična, gladka

▲ Cena za kos

Za širino primeža	A	A ₁	D	D ₁	D ₂	E	M	M ₁	M ₂
90	90		34,9	17			64	35,9	28,1

EUR 364,00

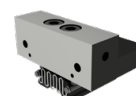
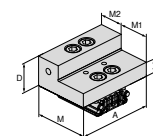

NEW

Y4	NCG	H5G / -S / -Z	X5G-Z / -S	ESG 4	ESG 5	HDG 2	ZSG 4	ZSG mini	DSG 4	Versto	HSG
80 914 32000										●	

Čeljust na prislonu, nepomična, stopnja 2,9 mm

▲ Cena za kos

Za širino primeža	A	A ₁	D	D ₁	D ₂	E	M	M ₁	M ₂
90	65		34,9	32	17		64	28,1	35,9
90	65	40	34,9	32	17		64	28,1	35,9
90	90		34,9	32	17		64	28,1	35,9

EUR 352,00
340,00
364,00

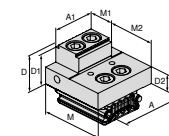

NEW

Y4	NCG	H5G / -S / -Z	X5G-Z / -S	ESG 4	ESG 5	HDG 2	ZSG 4	ZSG mini	DSG 4	Versto	HSG
80 914 31100										●	
80 914 31000										●	
80 914 31200										●	

Obrnljiva nastavljiva čeljust, profilirana, stopnja 2,9 mm

▲ Cena za kos

Za širino primeža	A	A ₁	D	D ₁	D ₂	E	M	M ₁	M ₂
90	65		34,9	32	17		64	42	22
90	65	40	34,9	32	17		64	42	22
90	90		34,9	32	17		64	42	22

EUR 352,00
340,00
364,00

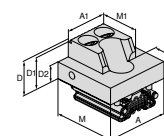

NEW

Y4	NCG	H5G / -S / -Z	X5G-Z / -S	ESG 4	ESG 5	HDG 2	ZSG 4	ZSG mini	DSG 4	Versto	HSG
80 914 31400										●	
80 914 31300										●	
80 914 31500										●	

Obrnljiva nastavljiva čeljust, gladka

▲ Cena za kos

Za širino primeža	A	A ₁	D	D ₁	D ₂	E	M	M ₁	M ₂
90	90		34,9	17			64	42	22

EUR 364,00

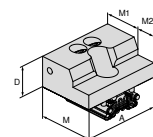

NEW

Y4	NCG	H5G / -S / -Z	X5G-Z / -S	ESG 4	ESG 5	HDG 2	ZSG 4	ZSG mini	DSG 4	Versto	HSG
80 914 31600										●	

Pregled sistemov čeljusti

Obrnljiva nastavljiva čeljust, visoka

▲ Cena za kos

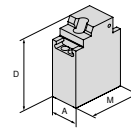

Za širino primeža	A	A ₁	D	D ₁	D ₂	E	M	M ₁	M ₂
90	65		165				124		

EUR 1.220,00

NEW

Y4

NCG	H5G / -S / -Z	X5G-Z / -S	ESG 4	ESG 5	HDG 2	ZSG 4	ZSG mini	DSG 4	Verzo	HSG
									●	

80 914 31700

Čeljust s prizmo, gladka, stopnja 2,9 mm

▲ Cena za kos

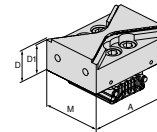

Za širino primeža	A	A ₁	D	D ₁	D ₂	E	M	M ₁	M ₂
90	90		34,9	32			64		

EUR 364,00

NEW

Y4

NCG	H5G / -S / -Z	X5G-Z / -S	ESG 4	ESG 5	HDG 2	ZSG 4	ZSG mini	DSG 4	Verzo	HSG
									●	

80 914 31900

Klinasta vpenjalna čeljust

▲ Cena za kos

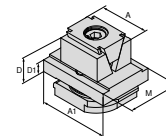

Za širino primeža	A	A ₁	D	D ₁	D ₂	E	M	M ₁	M ₂
90	40	65	35	11			49		
90	40	65	39	11			49		

EUR 347,00
236,00

NEW

Y4

NCG	H5G / -S / -Z	X5G-Z / -S	ESG 4	ESG 5	HDG 2	ZSG 4	ZSG mini	DSG 4	Verzo	HSG
									●	
									●	

80 914 32100
80 914 32400

Klinasta vpenjalna čeljust, prijemalna, stopnja

▲ Cena za kos

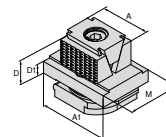

Za širino primeža	A	A ₁	D	D ₁	D ₂	E	M	M ₁	M ₂
90	40	65	35	11			49		
90	40	65	39	11			49		

EUR 371,00
236,00

NEW

Y4

NCG	H5G / -S / -Z	X5G-Z / -S	ESG 4	ESG 5	HDG 2	ZSG 4	ZSG mini	DSG 4	Verzo	HSG
									●	
									●	

80 914 32200
80 914 32500

Klinasta vpenjalna čeljust, prijemalna, stopnja 3 mm

▲ Cena za kos

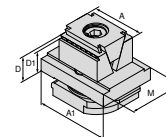

Za širino primeža	A	A ₁	D	D ₁	D ₂	E	M	M ₁	M ₂
90	40	65	35	32			49		

EUR 371,00

NEW

Y4

NCG	H5G / -S / -Z	X5G-Z / -S	ESG 4	ESG 5	HDG 2	ZSG 4	ZSG mini	DSG 4	Verzo	HSG
									●	

80 914 32300

Pregled sistemov čeljusti

Čeljust, prijemalna

▲ Cena za kos

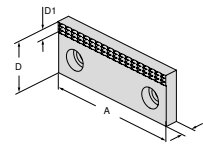

Za širino primeža	A	A ₁	D	D ₁	D ₂	E	M	M ₁	M ₂	EUR	NEW	Y4	NCG	H5G / -S / -Z	X5G-Z / -S	ESG 4	ESG 5	HDG 2	ZSG 4	ZSG mini	DSG 4	Verso	HSG	
65	65		35	7			10			41,00		80 889 656												
65	40		35	7			10			36,80		80 889 406												
90	90		35	7			10			46,50		80 889 906												

Mehka čeljust

▲ Material: 16MnCr5

▲ Cena za kos

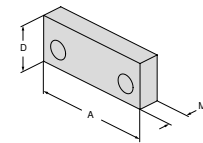

Za širino primeža	A	A ₁	D	D ₁	D ₂	E	M	M ₁	M ₂	EUR	NEW	Y4	NCG	H5G / -S / -Z	X5G-Z / -S	ESG 4	ESG 5	HDG 2	ZSG 4	ZSG mini	DSG 4	Verso	HSG	
65	65		35				16			41,00		80 889 657												
65	40		35				16			37,80		80 889 407												
90	90		35				16			49,70		80 889 907												

Osnovna čeljust

▲ Cena za kos

▲ Za alu čeljust št. 80 914 34200

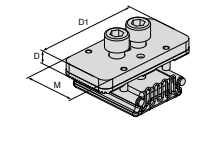

Za širino primeža	A	A ₁	D	D ₁	D ₂	E	M	M ₁	M ₂	EUR	NEW	Y4	NCG	H5G / -S / -Z	X5G-Z / -S	ESG 4	ESG 5	HDG 2	ZSG 4	ZSG mini	DSG 4	Verso	HSG	
90			9,1	80			40			212,00		80 914 34100												

Aluminijasta čeljust, mehka

▲ Cena za kos

▲ Za osnovno čeljust št. 80 914 34100

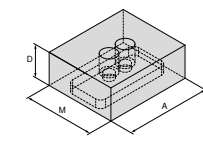

Za širino primeža	A	A ₁	D	D ₁	D ₂	E	M	M ₁	M ₂	EUR	NEW	Y4	NCG	H5G / -S / -Z	X5G-Z / -S	ESG 4	ESG 5	HDG 2	ZSG 4	ZSG mini	DSG 4	Verso	HSG	
90	90		34,9				75			81,00		80 914 34200												

Čeljust z vlekem navzdol, prijemalna

▲ Cena za kos

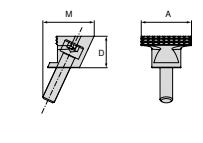

Za širino primeža	A	A ₁	D	D ₁	D ₂	E	M	M ₁	M ₂	EUR	NEW	Y4	NCG	H5G / -S / -Z	X5G-Z / -S	ESG 4	ESG 5	HDG 2	ZSG 4	ZSG mini	DSG 4	Verso	HSG	
90	40		25				41			105,00		80 914 32600												

Pregled sistemov čeljusti

Čeljust z vlekem navzdol, prijemalna, okrogla

▲ Cena za kos

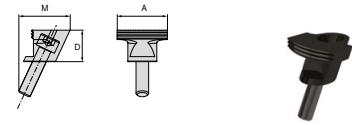

Za širino primeža	A	A ₁	D	D ₁	D ₂	E	M	M ₁	M ₂
90	40		25				41		

EUR

NEW

Y4

118,00

80 914 32700

NCG	H5G / -S / -Z	X5G-Z / -S	ESG 4	ESG 5	HDG 2	ZSG 4	ZSG mini	DSG 4	Verso	HSG
									●	

Vzporedna vpenjalna čeljust, prijemalna, okrogla

▲ Cena za kos

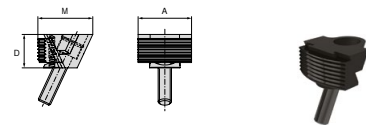

Za širino primeža	A	A ₁	D	D ₁	D ₂	E	M	M ₁	M ₂
90	40		25				41		

EUR

NEW

Y4

219,00

80 914 32800

NCG	H5G / -S / -Z	X5G-Z / -S	ESG 4	ESG 5	HDG 2	ZSG 4	ZSG mini	DSG 4	Verso	HSG
									●	

Vzporedna vpenjalna čeljust

▲ Cena za kos

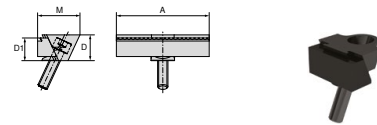

Za širino primeža	A	A ₁	D	D ₁	D ₂	E	M	M ₁	M ₂
90	40		25	22			41		
90	65		25	22			41		
90	90		25	22			41		

EUR

NEW

Y4

175,00

80 914 32900

216,00

80 914 33000

259,00

80 914 33100

NCG	H5G / -S / -Z	X5G-Z / -S	ESG 4	ESG 5	HDG 2	ZSG 4	ZSG mini	DSG 4	Verso	HSG
									●	
									●	
									●	

Nihajoča čeljust, prijemalna

▲ Cena za kos

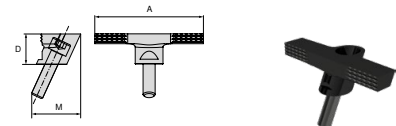

Za širino primeža	A	A ₁	D	D ₁	D ₂	E	M	M ₁	M ₂
90	90		25				41		

EUR

NEW

Y4

182,00

80 914 33200

NCG	H5G / -S / -Z	X5G-Z / -S	ESG 4	ESG 5	HDG 2	ZSG 4	ZSG mini	DSG 4	Verso	HSG
									●	

Vpenjalni klin

▲ Cena za kos

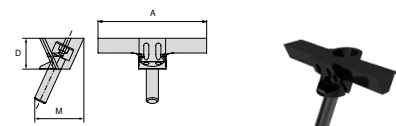

Za širino primeža	A	A ₁	D	D ₁	D ₂	E	M	M ₁	M ₂
90	90		25				41		

EUR

NEW

Y4

200,00

80 914 33300

NCG	H5G / -S / -Z	X5G-Z / -S	ESG 4	ESG 5	HDG 2	ZSG 4	ZSG mini	DSG 4	Verso	HSG
									●	

Pregled sistemov čeljusti

Vzporedna vpenjalna čeljust, gladka

▲ Cena za kos

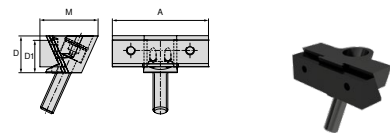

Za širino primeža	A	A ₁	D	D ₁	D ₂	E	M	M ₁	M ₂	EUR	NEW	Y4	NCG	H5G / -S / -Z	X5G-Z / -S	ESG 4	ESG 5	HDG 2	ZSG 4	ZSG mini	DSG 4	Verso	HSG	
90	40		25	22			41			167,00		80 914 33400												
90	65		25	22			41			271,00		80 914 33500												
90	90		25	22			41			286,00		80 914 33600												

Vzporedna vpenjalna čeljust, prijemalna

▲ Cena za kos

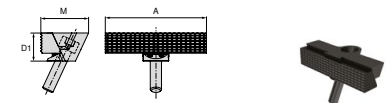

Za širino primeža	A	A ₁	D	D ₁	D ₂	E	M	M ₁	M ₂	EUR	NEW	Y4	NCG	H5G / -S / -Z	X5G-Z / -S	ESG 4	ESG 5	HDG 2	ZSG 4	ZSG mini	DSG 4	Verso	HSG	
90	90				25		42,5			259,00		80 914 33700												

Vpenjalna čeljust, jeklena

▲ Material: 16MnCr5

▲ Cena za kos

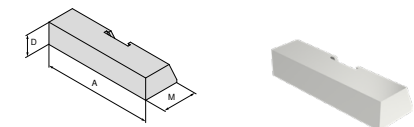

Za širino primeža	A	A ₁	D	D ₁	D ₂	E	M	M ₁	M ₂	EUR	NEW	Y4	NCG	H5G / -S / -Z	X5G-Z / -S	ESG 4	ESG 5	HDG 2	ZSG 4	ZSG mini	DSG 4	Verso	HSG	
90	90		18				30			83,20		80 914 33800												

Vpenjalna čeljust, aluminijasta

▲ Cena za kos

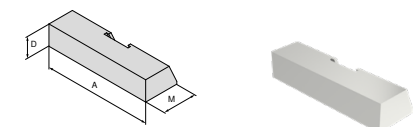

Za širino primeža	A	A ₁	D	D ₁	D ₂	E	M	M ₁	M ₂	EUR	NEW	Y4	NCG	H5G / -S / -Z	X5G-Z / -S	ESG 4	ESG 5	HDG 2	ZSG 4	ZSG mini	DSG 4	Verso	HSG	
90	90		18				30			83,20		80 914 33900												

Adapterska čeljust, nepomična

▲ Za vpenjanje 6-delnih obrnljivih čeljusti

▲ Cena za kos

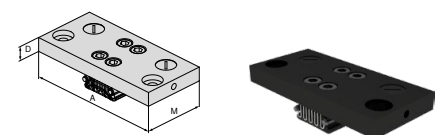

Za širino primeža	A	A ₁	D	D ₁	D ₂	E	M	M ₁	M ₂	EUR	NEW	Y4	NCG	H5G / -S / -Z	X5G-Z / -S	ESG 4	ESG 5	HDG 2	ZSG 4	ZSG mini	DSG 4	Verso	HSG	
90	160		17				74			453,00		80 914 34000												

Pregled sistemov čeljusti

6-delni čeljustni nastavek

- ▲ 1 = Gladka, prevlečena z volframovim karbidom
- ▲ 2 = Prijemalo s stopnico 3 mm
- ▲ 3 = Prijemalo s stopnico 8 mm
- ▲ 4 = Prijemalo s stopnico 18 mm
- ▲ 5 = Prijemalo, okroglo, s stopnico 8 mm
- ▲ 6 = Prijemalo, okroglo
- ▲ $M_{najv.} = 60 \text{ Nm}$
- ▲ Vklj. s pritrdilnimi vijaki

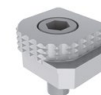
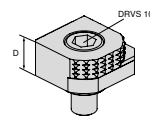

Za širino primeža	A	A ₁	D	D ₁	D ₂	E	M	M ₁	M ₂	EUR	Y4	NCG	H5G / -S / -Z	X5G-Z / -S	ESG 4	ESG 5	HDG 2	ZSG 4	ZSG mini	DSG 4	Verso	HSG	
			18							80,60	80 892 246	●	●	●	●				●		●	●	

6-delni čeljustni nastavek, s prijemalom iz karbidne trdine

- ▲ 1 = gladka
- ▲ 2 = karbidno prijemalo
- ▲ 3 = karbidno prijemalo s stopnico 3 mm
- ▲ 4 = karbidno prijemalo s stopnico 8 mm
- ▲ 5 = karbidno prijemalo, okroglo, s stopnico 8 mm
- ▲ 6 = karbidno prijemalo, okroglo
- ▲ vklj. s pritrdilnimi vijaki

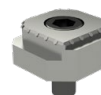
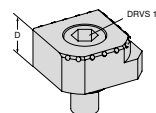

Za širino primeža	A	A ₁	D	D ₁	D ₂	E	M	M ₁	M ₂	EUR	Y4	NCG	H5G / -S / -Z	X5G-Z / -S	ESG 4	ESG 5	HDG 2	ZSG 4	ZSG mini	DSG 4	Verso	HSG	
			18							117,00	80 890 35300	●	●	●	●				●		●	●	

Pregled podlog za obdelovance

Podloga za obdelovance

▲ Cena za 2 kosa

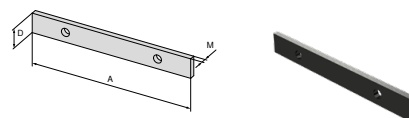

Za širino primeža	A	A ₁	D	D ₁	D ₂	E	M	M ₁	M ₂
90	90		11				3		

EUR

NEW

Y4

52,90

80 914 73100

NEW	Y4	NCG	H5G / -S / -Z	X5G-Z / -S	ESG 4	ESG 5	HDG 2	ZSG 4	ZSG mini	DSG 4	Verso	HSG
											●	

Podloga za obdelovaneč, z odmikom

▲ Cena za 2 kosa

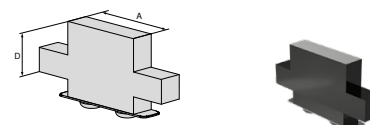

Za širino primeža	A	A ₁	D	D ₁	D ₂	E	M	M ₁	M ₂
90	40		30						
90	40		25						

EUR

NEW

Y4

87,40

80 914 70200

87,40

80 914 70100

NEW	Y4	NCG	H5G / -S / -Z	X5G-Z / -S	ESG 4	ESG 5	HDG 2	ZSG 4	ZSG mini	DSG 4	Verso	HSG
											●	
											●	

Podloga za obdelovaneč, z odmikom

▲ Cena za 2 kosa

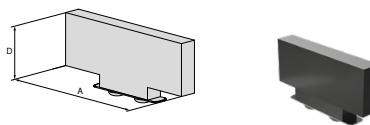

Za širino primeža	A	A ₁	D	D ₁	D ₂	E	M	M ₁	M ₂
90	65		11						
90	65		17						
90	65		25						
90	65		30						

EUR

NEW

Y4

87,40

80 914 71100

87,40

80 914 71200

87,40

80 914 71300

87,40

80 914 71400

NEW	Y4	NCG	H5G / -S / -Z	X5G-Z / -S	ESG 4	ESG 5	HDG 2	ZSG 4	ZSG mini	DSG 4	Verso	HSG
											●	
											●	
											●	
											●	

Podloga za obdelovaneč, z odmikom

▲ Cena za 2 kosa

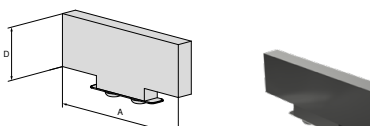

Za širino primeža	A	A ₁	D	D ₁	D ₂	E	M	M ₁	M ₂
90	90		11						
90	90		17						
90	90		25						
90	90		30						

EUR

NEW

Y4

87,40

80 914 72100

87,40

80 914 72200

87,40

80 914 72300

87,40

80 914 72400

NEW	Y4	NCG	H5G / -S / -Z	X5G-Z / -S	ESG 4	ESG 5	HDG 2	ZSG 4	ZSG mini	DSG 4	Verso	HSG
											●	
											●	
											●	
											●	

Pregled pribora za sisteme

Nastavljivi nosilec z osnovnim telesom

- ▲ Za dušenje vibracij
- ▲ Nastavljivo po višini 16 – 17 mm

Verso

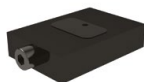
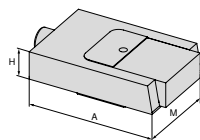

NEW

80 914 ...

EUR
Y4
243,00 50100

H mm	A mm	M mm
16	72	50

Komplet T-utornih vpenjalnih vijakov za MNG

- Obseg dobave:
Vpenjalni vijak s T-utorno matico

Verso



NEW

80 914 ...

EUR
Y4
42,20 50500
49,70 50600
60,50 50700

Za širino utorov mm	G
20	M12
22	M12
24	M12

Nosilec

- ▲ Za dušenje vibracij: Kataloška št. 80 914 50100

Verso

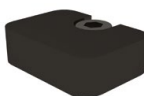
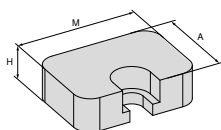

NEW

80 914 ...

EUR
Y4
62,70 50200
62,70 50300

H mm	A mm	M mm
8	20	28
13	20	28

Izravnalni čep

Verso



NEW

80 914 ...

EUR
Y4
107,00 81400
107,00 81600
107,00 81800

D ₁ mm	D ₂ mm
12	14
12	16
12	18

Spojno držalo

- ▲ Za povezavo 2 osnovnih teles

Verso

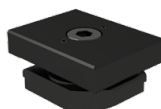
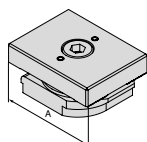

NEW

80 914 ...

EUR
Y4
183,00 50400

A mm
90

Pokrov

Verso

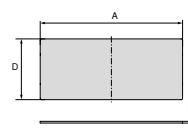

NEW

80 914 ...

EUR
Y4
15,80 51000
6,80 50800
10,10 50900

A mm	D mm	M mm
50	84	0,5
50	86	0,5
200	86	0,5

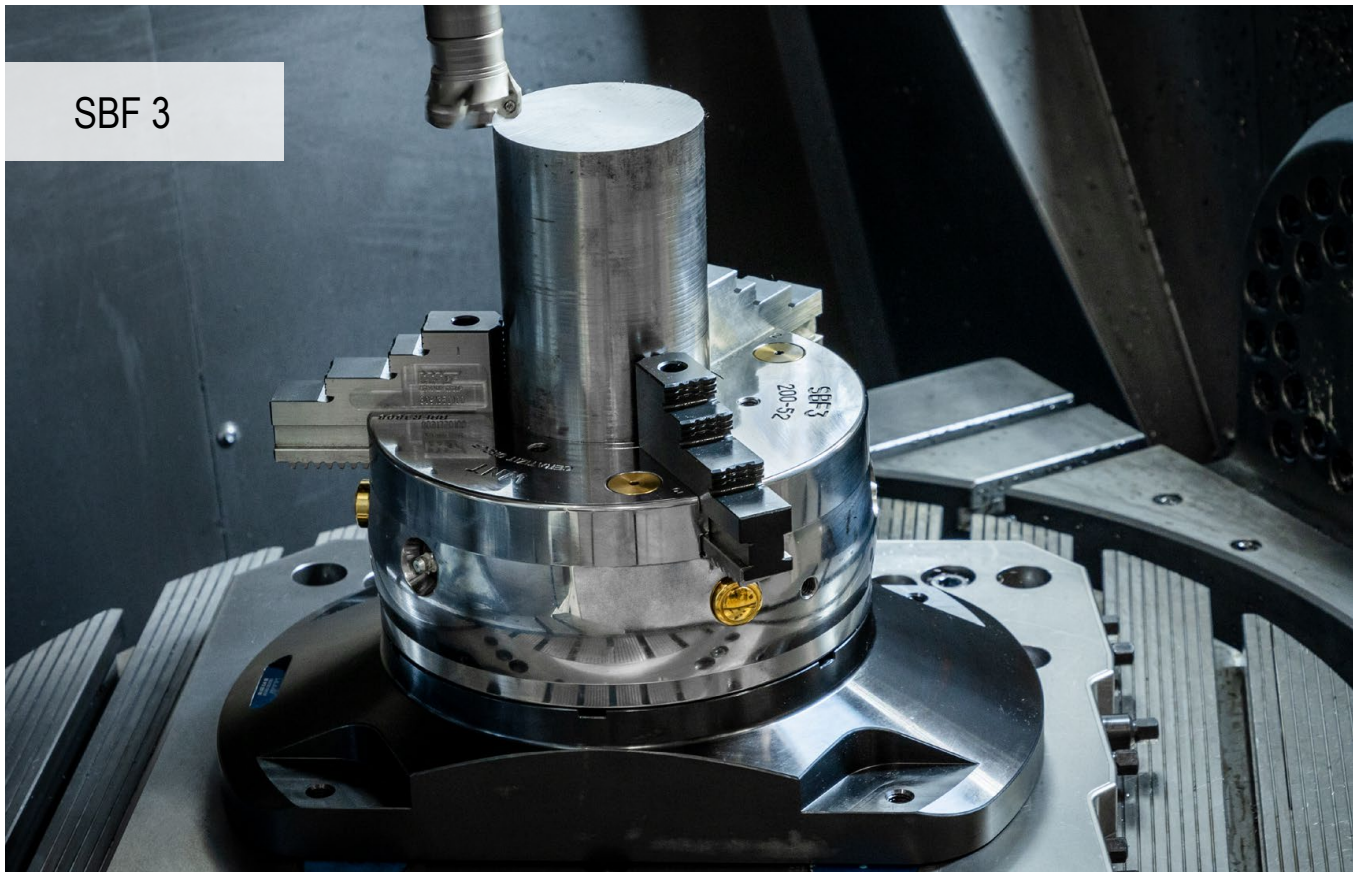

Nestrpno smo jo pričakovali – in zdaj je končno na voljo

Obdelava okroglih komponent je zdaj postala del vsakodnevnih opravil. S stacionarno tričeljustno vpenjalno glavo SBF 3 imamo zdaj v svoji ponudbi rešitev, ki je popolnoma združljiva z našimi vpenjalnimi sistemi MNG in PNG z ničelno točko za hitro in preprosto uporabo.

Prednosti za vas:

- ▲ primerno za 3/5-osno obdelavo okroglih komponent
- ▲ združljivo z vpenjalnimi sistemi z ničelno točko PNG in MNG
- ▲ Sistem za hitro menjavo čeljusti s sprostitvijo posamezne čeljusti
- ▲ Vreteno s šesterorobim priključkom



SBF 3 Ø 200 mm



SBF 3 Ø 315 mm

Tehnične informacije – slika reza

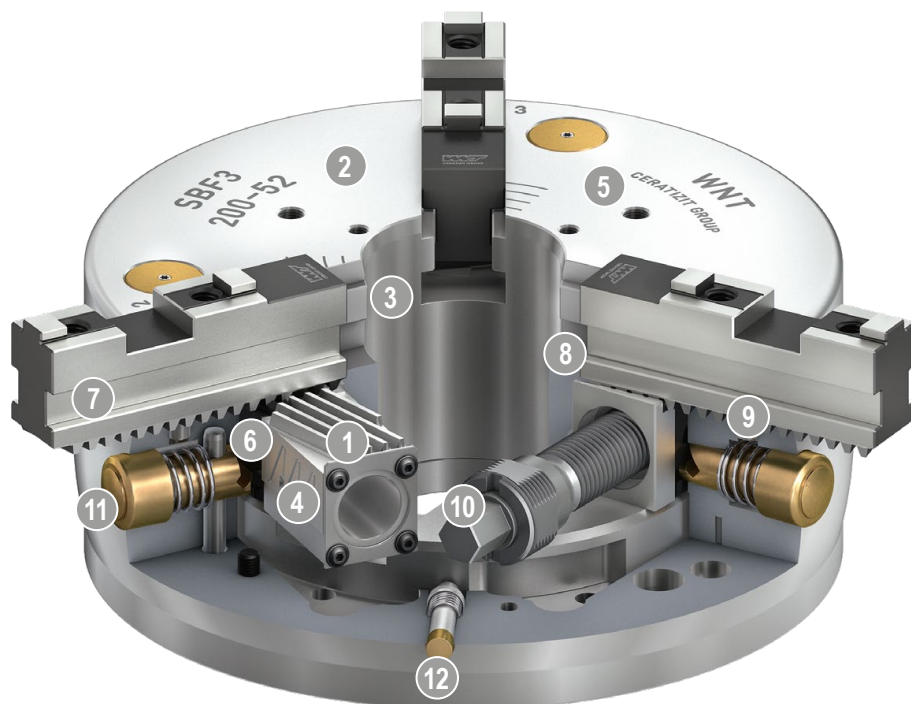

- | | |
|--|--|
| <p>1 Pogon letve s klinom
omogoča odlične rezultate obdelave</p> | <p>7 Osnovne čeljusti s kotnim ozobljenjem (SFG)</p> |
| <p>2 Kaljeno in izjemno togo osnovno telo,
kar omogoča daljšo življenjsko dobo z najvišjo preciznostjo – tudi pri največji vpenjalni sili</p> | <p>8 Mehanizem za zaklepanje
zagotavlja varen vbod ozobljenja osnovne čeljusti z ozobljenjem letve s klinom</p> |
| <p>3 Velika skožnja izvrtina
za obdelavo vseh običajnih premerov materiala drogov (opcijsko: povečanje skožnje izvrtine)</p> | <p>9 Zaskočni zatič
za predhodno pozicioniranje osnovnih čeljusti</p> |
| <p>4 Optimiziran sistem mazanja
za visoko učinkovitost</p> | <p>10 Aktiviranje s šestorobim priključkom,
kar omogoča enostavnejše upravljanje</p> |
| <p>5 Pritrdilni navoj
za prisilone za obdelovance ali zvezdaste naslone</p> | <p>11 Gumb za menjavo čeljusti
za najkrajše čase menjave</p> |
| <p>6 Sistem za hitro menjavo čeljusti
s sprostivjo posamezne čeljusti, kar omogoča najkrajše čase menjave</p> | <p>12 Indikatorski zatič
za vizualno spremljanje hoda ročne vpenjalne glave</p> |

Tričeljustna vpenjalna glava SBF 3 (premer 200 mm) s konzolo

- ▲ primerno za 3/5-osno obdelavo okroglih komponent
- ▲ združljivo z vpenjalnimi sistemi z ničelno točko PNG in MNG (vpenjalne spono z ničelno točko morate naročiti posebej)
- ▲ Sistem za hitro menjavo čeljusti s sprostivjo posamezne čeljusti
- ▲ Vreteno s šestrorobnim priključkom

Obseg dobave:

Tričeljustna vpenjalna glava SBF 3 (premer 200 mm) s konzolo (združljiva s PNG in MNG)

- 1 komplet osnovnih čeljusti GBA
- 1 komplet stopničastih čeljusti SB-H
- 6 pritrdilnih vijakov in vpenjalni ključ

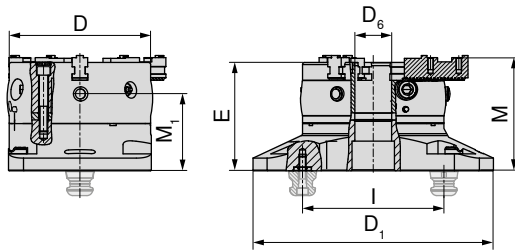

D	D ₁	D ₆	E	I	M	M ₁	MXC	TQX	DRVS	Hod/čeljust	Delitev zob	WT
mm	mm	mm	mm	mm	mm	mm	kN	Nm	mm	mm	mm	kg
200	340	52	153,3	200	160,1	108,8	100	120	12	7	4,8	49,5

80 913 ...

EUR
Y4

3.964,00 20000

Tričeljustna vpenjalna glava SBF 3 (premer 315 mm) s konzolo

- ▲ primerno za 3/5-osno obdelavo okroglih komponent
- ▲ združljivo z vpenjalnimi sistemi z ničelno točko PNG in MNG (vpenjalne spono z ničelno točko morate naročiti posebej)
- ▲ Sistem za hitro menjavo čeljusti s sprostivjo posamezne čeljusti
- ▲ Vreteno s šestrorobnim priključkom

Obseg dobave:

Tričeljustna vpenjalna glava SBF 3 (premer 315 mm) s konzolo (združljiva s PNG in MNG)

- 1 komplet osnovnih čeljusti GBA
- 1 komplet stopničastih čeljusti SB-H
- 6 pritrdilnih vijakov in vpenjalni ključ

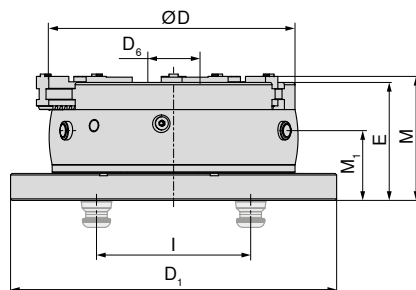

D	D ₁	D ₆	E	I	M	M ₁	MXC	TQX	DRVS	Hod/čeljust	Delitev zob	WT
mm	mm	mm	mm	mm	mm	mm	kN	Nm	mm	mm	mm	kg
315	423	92	153	200	160,86	90,5	180	220	16	9,9	7	95

80 913 ...

EUR
Y4

6.537,00 31500



Glava je zasnovana izključno za stacionarno uporabo – uporaba pri vrtenju ni dovoljena!

Pregled sistemov čeljusti

Osnovne čeljusti (GBA) – komplet

▲ Osnovne čeljusti s poševnim ozobljenjem

▲ Cena za komplet s 3 kosi

Obseg dobave:

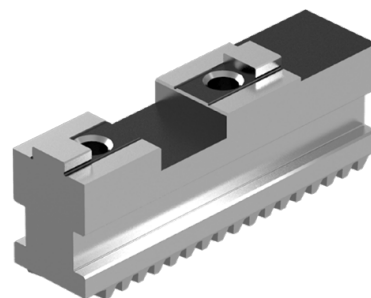
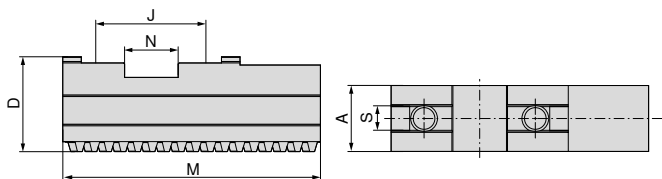
3 osnovne čeljusti s poševnim ozobljenjem
vključno s cilindričnimi vijakiSBF
3

za	A	D	J	M	N	S	G	WT
	mm	mm	mm	mm	mm	mm		kg
SBF-3.200	22	32	40	90	20	10	M8x1	1,2
SBF-3.315	32	43	54	125	26	12	M12x1,5	3,1

80 913 ...

EUR
Y4242,00 50300
400,00 60300

Čeljustni nastavki v mehki izvedbi (AB-W) – komplet

▲ Cena za komplet s 3 kosi

▲ Material: 16MnCr5

Obseg dobave:

3 čeljustni nastavki v mehki izvedbi

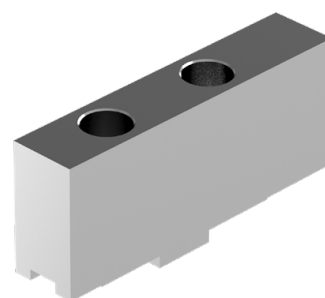
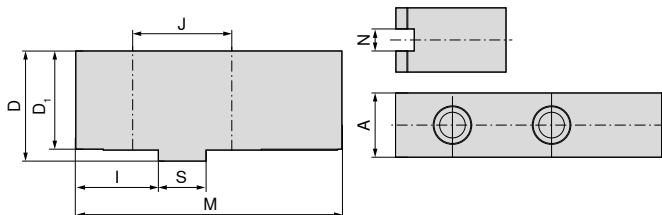
SBF
3

za	A	D	D ₁	I	J	M	N	S	Izvrtina za	WT
	mm	mm	mm	mm	mm	mm	mm	mm		kg
SBF-3.200	22	47	43	35	40	105	10	20	M8	2,0
SBF-3.315	35	60	54	45	54	145	12	26	M12	5,6

80 913 ...

EUR
Y447,30 50400
98,20 60400

Pregled sistemov čeljusti

Stopničasti čeljustni nastavki v trdi izvedbi (AB-H) – komplet

▲ Cena za komplet s 3 kosi

Obseg dobave:

3 stopničasti čeljustni nastavki v trdi izvedbi

**SBF
3**

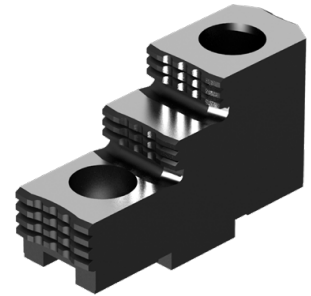
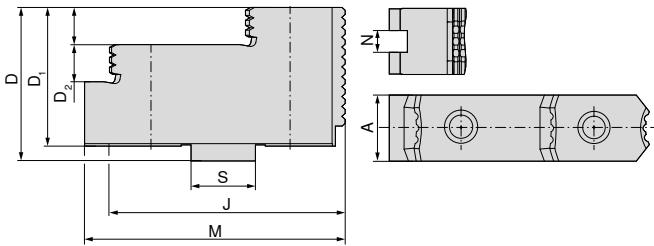

80 913 ...

za	A mm	D mm	D ₁ mm	D ₂ mm	J mm	M mm	N mm	S mm	Izvrtna za	WT kg	EUR Y4
SBF-3.200	22	42	38	10	40	71,7	10	20	M8	2,4	207,00 50200
SBF-3.315	36	62	56	15	54	105	12	26	M12	3,3	303,00 60200

Preglednica z merami – trd stopničasti čeljustni nastavek (AB-H)

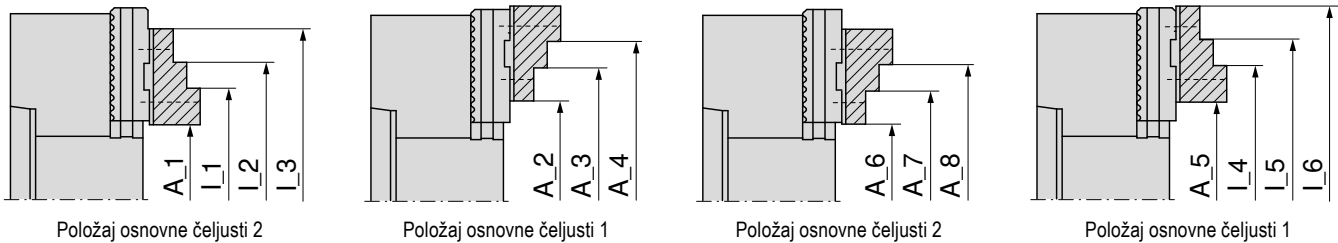

Tričeljustna vpenjalna glava	Sistemske čeljusti	Zunanje vpetje							
		A_1	A_2	A_3	A_4	A_5	A_6	A_7	A_8
SBF-3.200	80 913 50200 SBF-3.AB-H.200.71.7.22.10	7-76	57-125	108-177	135-204	55-125	14-77	66-129	93-156
SBF-3.315	80 913 60200 SBF-3.AB-H.315.105.36.15	14-125	93-224	202-333	-	87-219	44-130	153-239	-

Tričeljustna vpenjalna glava	Sistemske čeljusti	Notranje vpetje					
		L_1	L_2	L_3	L_4	L_5	L_6
SBF-3.200	80 913 50200 SBF-3.AB-H.200.71.7.22.10	72-141	99-168	151-220	120-189	147-216	199-268
SBF-3.315	80 913 60200 SBF-3.AB-H.315.105.36.15	93-204	202-313	-	167-298	276-407	-

Pregled sistemov čeljusti

Stopničaste blok čeljusti v trdi izvedbi (SB-H) – komplet

▲ Stopničaste blok čeljusti s poševnim ozobljenjem

▲ Cena za komplet s 3 kosi

Obseg dobave:

3 stopničaste blok čeljusti v trdi izvedbi

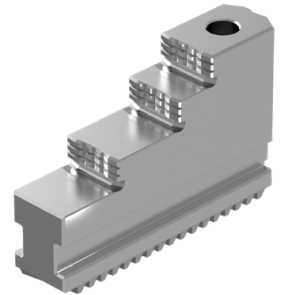
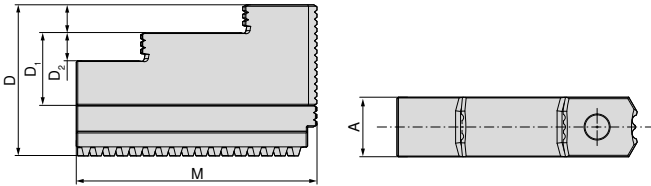
SBF
3

za	A	D	D ₁	D ₂	M	WT
	mm	mm	mm	mm	mm	kg
SBF-3.200	22	60	35	10	94	1,9
SBF-3.315	32	81	46	15	129	5,5

80 913 ...

EUR
Y4

420,00 50100

661,00 60100

Preglednica z merami – trde stopničaste blokirne čeljusti (SB-H)

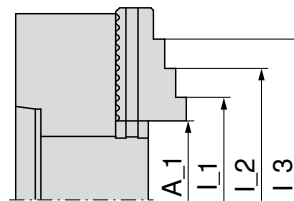
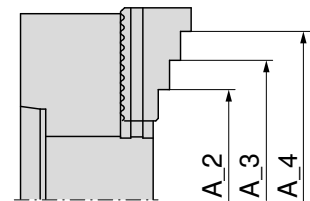
Trde stopničaste blokirne čeljusti
jeklo 16MnCr5, kaljeneTrde stopničaste blokirne čeljusti
jeklo 16MnCr5, kaljene

Tričeljustna vpenjalna glava	Sistemske čeljusti		Zunanje vpetje				Notranje vpetje		
			A_1	A_2	A_3	A_4	I_1	I_2	I_3
SBF-3.200	80 913 50100	SBF-3.SB-H.200.94.22.10	6–74	59–128	111–180	138–207	70–138	97–165	149–217
SBF-3.315	80 913 60100	SBF-3.SB-H.315.129.32.15	12–124	89–210	189–420	–	91–203	199–311	–

Ročni primež za vrtalne stroje

- ▲ Priročen, univerzalen primež z velikim območjem vpenjanja
- ▲ Čeljusti s stopnico ter vodoravno in navpično prizmo 120°
- ▲ Kot dodatna oprema je na voljo omejevalnik materiala na obeh straneh

HSG

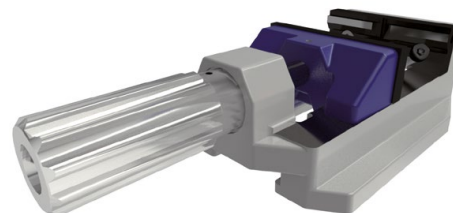
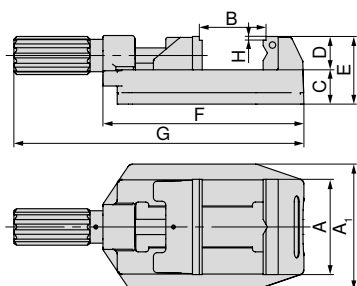

A	A ₁	B	C	D	E	F	G	H	WT
mm	mm	mm	mm	mm	mm	mm	mm	mm	kg
80	112	0 - 81	36	35	71	194	286,5	4	4,5
100	132	0 - 100	36	35	71	211	304,5	4	5,6
125	156	0 - 131	40	40	84	274	386	4	11,2

80 893 ...

EUR
Y4

286,00 080

303,00 100

506,00 125

Ročni primež za vrtalne stroje s pripomočkom za vpenjanje

- ▲ Varno in hitro vpenjanje obdelovancev s pripomočkom za vpenjanje
- ▲ Priročen, univerzalen primež z velikim območjem vpenjanja
- ▲ Čeljusti s stopnico ter vodoravno in navpično prizmo 120°
- ▲ Kot dodatna oprema je na voljo omejevalnik materiala na obeh straneh
- ▲ N = območje hoda pri vpenjanju ročice

HSG

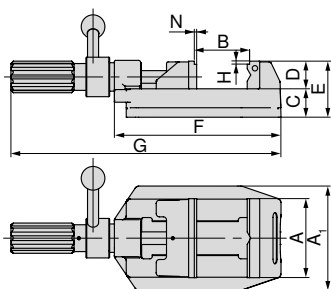

A	A ₁	B	C	D	E	F	G	H	N	WT
mm	mm	mm	mm	mm	mm	mm	mm	mm	mm	kg
100	132	0 - 100	36	35	71	211	342	4	1,5	6,1
125	156	0 - 133	44	40	84	274	405	4	1,5	11,7

80 893 ...

EUR
Y4

491,00 101

702,00 126

Vodnik po primežih

Pribor za sisteme

132+133 Splošni pribor

164-183

Pregled čeljustnih nastavkov

Stopničasta čeljust, gladka

▲ Cena za kos

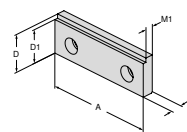

Za širino primeža	A	A ₁	D	D ₁	D ₂	E	M	M ₁	M ₂	EUR	Y4	NCG	H5G / -S / -Z	X5G-Z / -S	ESG 4	ESG 5	HDG 2	ZSG 4	ZSG mini	DSG 4	Verso	HSG		
80			35	31			10,2	7,2		49,00	80 893 082												●	
100			35	31			10,2	7,2		45,00	80 893 102													●
125			40	36			11,8	8,8		58,00	80 893 127													●

Stopničasta čeljust, 17 mm

▲ Cena za kos

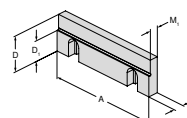

Za širino primeža	A	A ₁	D	D ₁	D ₂	E	M	M ₁	M ₂	EUR	Y4	NCG	H5G / -S / -Z	X5G-Z / -S	ESG 4	ESG 5	HDG 2	ZSG 4	ZSG mini	DSG 4	Verso	HSG		
125			40	23			11,5	9,5		123,00	80 892 244													●

Čeljust s prizmo

▲ Čeljust z vodoravno in navpično prizmo

▲ Cena za kos

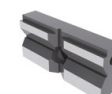
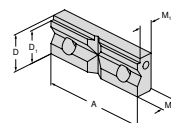

Za vpenjalni premer	A	A ₁	D	D ₁	D ₂	E	M	M ₁	M ₂	EUR	Y4	NCG	H5G / -S / -Z	X5G-Z / -S	ESG 4	ESG 5	HDG 2	ZSG 4	ZSG mini	DSG 4	Verso	HSG			
9 - 31	80		35	31			15,8	12,8		58,00	80 893 083													●	
9 - 31	100		35	31			15,8	12,8		74,00	80 893 103														●
11 - 41	125		40	36			17,8	14,8		129,00	80 893 128														●



→ Stran 164–173

Tukaj boste našli druge ustrezne zgornje čeljusti.

Pregled pribora za sisteme

Prislon za obdelovanec

- ▲ Se pritrdi na vpenjalo, po izbiri levo, desno ali na obeh straneh.
- Aksialno spreminjanje dolžine je prek vpenjalnega vijaka hitro in varno.

HSG



Za širino
mm
80/100/125

80 893 ...

EUR
Y4
46,00 265

Vodilo

- ▲ Preprečuje nesreče
- ▲ Preprečuje pobiranje, sunkovito obračanje in dvigovanje

HSG

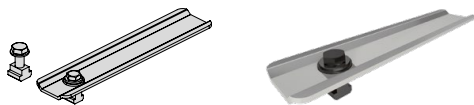

Za širino
mm
80/100/125

80 893 ...

EUR
Y4
50,00 260

Vpenjalni komplet

- ▲ S premično oporo z ekscentričnim vrtljivim uležajenjem je mogoče nastaviti želene položaje vpenjanja na strojnih mizah z različnimi razporeditvami T-utorov. Kot pri vodilih 80 893 260 obstaja dodatna možnost pritrdjevanja prek notranjega utora telesa primeža.
- ▲ Cena za komplet

Obseg dobave:

2 vpenjalni sponi za določanje položaja, vklj. z dodatno opremo za vpenjanje

HSG



Za širino
mm
80/100/125

Za širino utorov
mm
12/14

80 893 ...

EUR
Y4
132,00 250

Pregled vpenjalnih sistemov z ničelno točko MNG in PNG

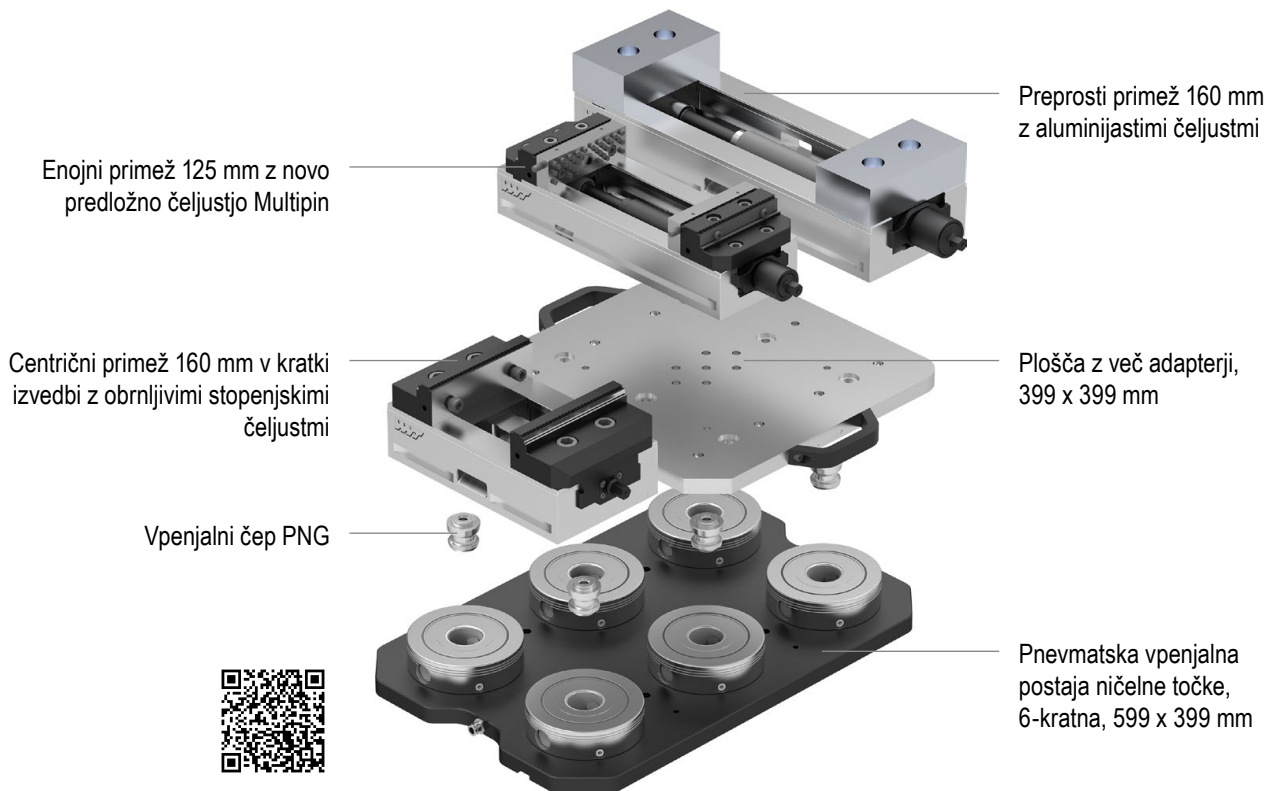

MNG – Osnovna plošča, okrogla

- ▲ MNG – mehanski vpenjalni sistem z ničelno točko
- ▲ Kaljeno in brušeno
- ▲ Natančnost ponovitve $\leq 0,01$ mm
- ▲ Vlečna sila 20 kN
- ▲ Pritezni moment 30 Nm

MNG

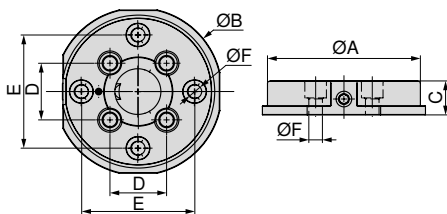

A	B	C _{+0,005}	D	E	F _{H7}	WT
mm	mm	mm	mm	mm	mm	kg
135	148	30	50	100	12	3,5

80 899 ...

EUR
Y4
571,00 125

Vodnik po primežih

Pripor za sisteme

144+145 Splošni pribor

164–183

MNG – Osnovna plošča, oglata

- ▲ MNG – mehanski vpenjalni sistem z ničelno točko
- ▲ Vlečna sila 20 kN na vpenjalnem čepu
- ▲ Nerjavna in vakumsko kaljena
- ▲ Natančnost ponovitve $\leq 0,01$ mm
- ▲ Pritezni moment 30 Nm

MNG

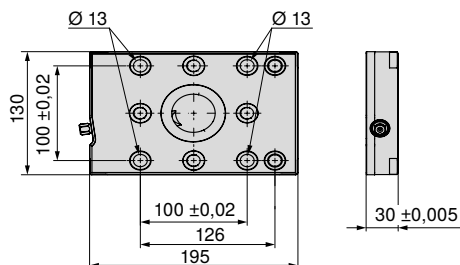

80 899 ...

EUR
Y4

702,00 65000

Velikost	WT
195x130 mm	5,2

MNG – Osnovna plošča, oglata, 2-kratno

- ▲ MNG – mehanski vpenjalni sistem z ničelno točko
- ▲ Vlečna sila 20 kN na vpenjalnem čepu
- ▲ Nerjavna in vakumsko kaljena
- ▲ Natančnost ponovitve $\leq 0,01$ mm
- ▲ Pritezni moment 30 Nm

MNG

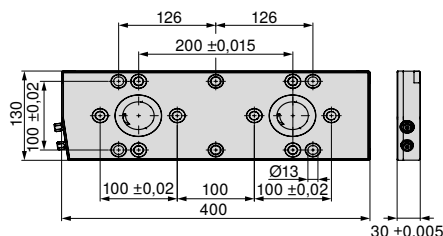

80 899 ...

EUR
Y4

1.650,00 65100

Velikost	WT
400x130 mm	11

Vodnik po primežih

Pribor za sisteme	144+145	Splošni pribor	164–183
Možnost vpenjanja MNG	146–148		

MNG – Osnovna plošča, oglata, 3-kratno

- ▲ MNG – mehanski vpenjalni sistem z ničelno točko
- ▲ Vlečna sila 20 kN na vpenjalnem čepu
- ▲ Nerjavna in vakumsko kaljena
- ▲ Natančnost ponovitve $\leq 0,01$ mm
- ▲ Pritezni moment 30 Nm

MNG

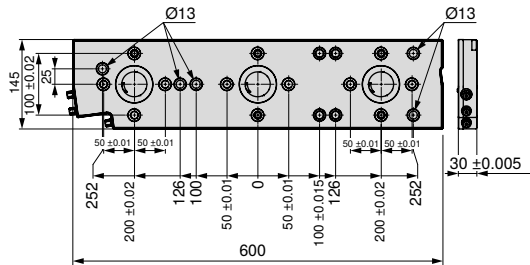

80 899 ...

EUR
Y4

2.340,00 65200

Velikost	WT
600x145 mm	18 kg

MNG – Osnovna plošča, 3-delna, 270 x 190 mm

- ▲ MNG – mehanski vpenjalni sistem z ničelno točko
- ▲ Vlečna sila 20 kN na vpenjalnem čepu
- ▲ 4x pritrdilne izvrtine za M12, za T-utor, razmik 50 mm
- ▲ 8x puša za rastrsko izvrtino Ø12 F7 / M12
- ▲ 4x izvrtina Ø18 H7 za določanje položaja

MNG

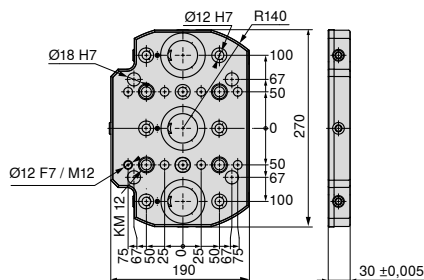

80 899 ...

EUR
Y4

2.110,00 230

Velikost	WT
270x190 mm	9 kg

Vodnik po primežih

Pribor za sisteme	144+145	Splošni pribor	164–183
Možnost vpenjanja MNG	146–148		

MNG – Osnovna plošča, 4-delna, 330 x 400 mm

- ▲ MNG – mehanski vpenjalni sistem z ničelno točko
- ▲ Nerjavna in vakumsko kaljena
- ▲ Vlečna sila 20 kN na vpenjalnem čepu
- ▲ 15 x pritrdilne izvrtine za M12, za T-utor, razmik 50, 63, 100, 125 mm
- ▲ 13 x prehodna izvrtina Ø12 F7/M12
- ▲ 2 x prehodna izvrtina Ø18 G7 za določanje položaja
- ▲ 1 x prehodna izvrtina Ø12 F7 za določanje položaja

MNG

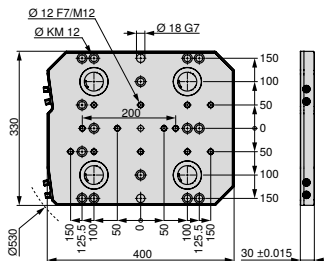

80 899 ...

EUR
Y43.290,00 63000¹⁾

Velikost	WT
330x400 mm	28

1) Ni na zalogi

MNG – Osnovna plošča, 6-delna, 400 x 400 mm

- ▲ MNG – mehanski vpenjalni sistem z ničelno točko
- ▲ Nerjavna in vakumsko kaljena
- ▲ Vlečna sila 20 kN na vpenjalnem čepu
- ▲ 14 x pritrdilne izvrtine za M16, za razdalje med T-utori 63, 80, 100, 125 mm
- ▲ 2 x pritrdilne izvrtine za M12
- ▲ 17 x prehodna izvrtina Ø12 F7/M12
- ▲ 2 x prehodna izvrtina Ø18 G7 za določanje položaja
- ▲ 1 x prehodna izvrtina Ø12 F7 za določanje položaja

MNG

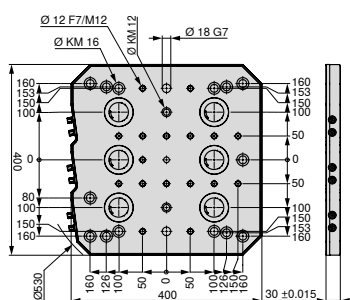

80 899 ...

EUR
Y44.510,00 63100¹⁾

Velikost	WT
400x400 mm	33

1) Ni na zalogi

Vodnik po primežih

Pribor za sisteme

144+145 Splošni pribor

164-183

MNG – Osnovna plošča, 6-delna, 400 x 530 mm

- ▲ MNG – mehanski vpenjalni sistem z ničelno točko
- ▲ Nerjavna in vakumsko kaljena
- ▲ Vlečna sila 20 kN na vpenjalnem čepu
- ▲ 24 x pritrdilne izvrtine za M12, za T-utor, razmik 63, 100, 125 mm
- ▲ 21 x prehodna izvrtina Ø12 F7/M12
- ▲ 2 x prehodna izvrtina Ø18 G7 za določanje položaja
- ▲ 1 x prehodna izvrtina Ø12 F7 za določanje položaja

MNG

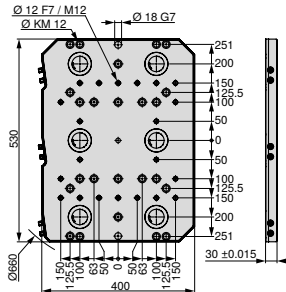

80 899 ...

EUR
Y44.880,00 63200¹⁾

Velikost	WT
400x530 mm	45

1) Ni na zalogi

MNG – Osnovna plošča, 10-delna, 496,5 x 532 mm

- ▲ MNG – mehanski vpenjalni sistem z ničelno točko
- ▲ Nerjavna in vakumsko kaljena
- ▲ Vlečna sila 20 kN na vpenjalnem čepu
- ▲ 27 x pritrdilne izvrtine za M12, za T-utor z razmikom 50, 63, 100, 125 mm in zvezdaste utore 45°
- ▲ 20 x prehodna izvrtina Ø12 F7/M12
- ▲ 2 x prehodna izvrtina Ø18 G7 za določanje položaja
- ▲ 1 x prehodna izvrtina Ø12 F7 za določanje položaja

MNG

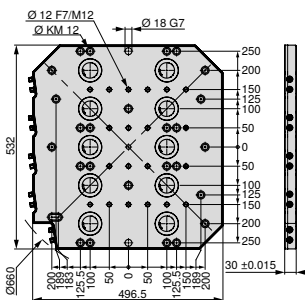

80 899 ...

EUR
Y46.930,00 63300¹⁾

Velikost	WT
497x532 mm	54

1) Ni na zalogi

Vodnik po primežih

Pribor za sisteme

144+145 Splošni pribor

164–183

MNG – Centrirni čep

▲ MNG – mehanski vpenjalni sistem z ničelno točko

MNG



80 899 ...

D ₁ h6 mm	D ₂ h6 mm	EUR Y4	
12	30	74,00	61700
12	32	73,50	61800
12	50	39,00	61900

MNG – Izravnalni čep

▲ MNG – mehanski vpenjalni sistem z ničelno točko

MNG



80 899 ...

D ₁ h6 mm	D ₂ h6 mm	EUR Y4	
18	14	46,50	607
18	18	46,50	608
18	20	61,50	609
18	22	61,50	610

MNG –
Komplet T-utornih vpenjalnih vijakov

▲ MNG – mehanski vpenjalni sistem z ničelno točko

Obseg dobave:

Vpenjalni vijak s T-utorno matico

MNG



80 899 ...

Za širino utorov mm	G	EUR Y4	
12	M8	31,10	63800
12	M10	11,50	63400
14	M8	31,10	63900
14	M12	13,80	63500 ¹⁾
16	M8	31,10	64000
16	M12	13,80	63600 ¹⁾
18	M8	31,10	64100
18	M12	13,80	63700 ¹⁾

1) Z vijaki z nizko glavo

MNG – Konzola z vpenjalnim modulom z ničelno točko

- ▲ MNG – mehanski vpenjalni sistem z ničelno točko
- ▲ Univerzalna uporaba na vseh strojnih mizah
- ▲ Vlečna sila 20 kN

Obseg dobave:

Konzola, vključno z okroglim vpenjalnim modulom MNG

MNG

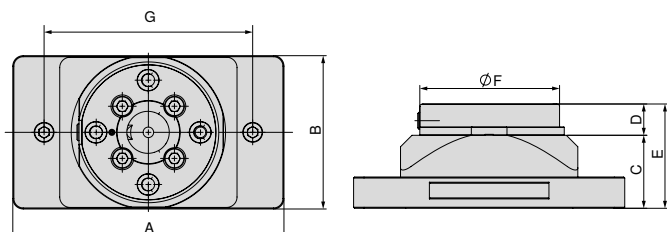

A	B	C	D	E	F	G	WT
mm	mm	mm	mm	mm	mm	mm	kg
260	147	70	30	100	135	200	8,9

80 899 ...

EUR
Y4

1.080,00 425

MNG – Konzola

- ▲ MNG – mehanski vpenjalni sistem z ničelno točko
- ▲ Univerzalna uporaba na vseh strojnih mizah
- ▲ Material: Aluminij, trdo anodiziran

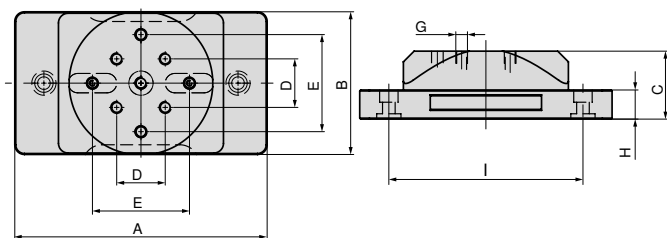

A	B	C	D	E _{±0,02}	G	H	I	WT
mm	mm	mm	mm	mm	M12	mm	mm	kg
260	147	70	50	100	M12	30	200	5,5

80 899 ...

EUR
Y4

519,00 420

Vodnik po primežih

Pribor za sisteme

144+145 Splošni pribor

164–183

MNG – Dvojna konzola z vpenjalnim modulom z ničelno točko

- ▲ MNG – mehanski vpenjalni sistem z ničelno točko
- ▲ Univerzalna uporaba na vseh strojnih mizah
- ▲ Material: Aluminij, trdo anodiziran

Obseg dobave:

Konzola, vključno z okroglim vpenjalnim modulom MNG

MNG

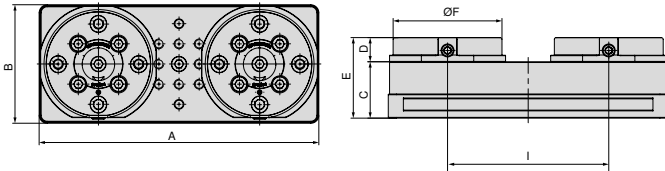

A	B	C	D	E	F	I	WT
mm	mm	mm	mm	mm	mm	mm	kg
347	147	70	30	100	135	200	16,5

80 899 ...

EUR
Y4

1.950,00 435

MNG – Dvojna konzola

- ▲ MNG – mehanski vpenjalni sistem z ničelno točko
- ▲ Univerzalna uporaba na vseh strojnih mizah
- ▲ Material: Aluminij, trdo anodiziran

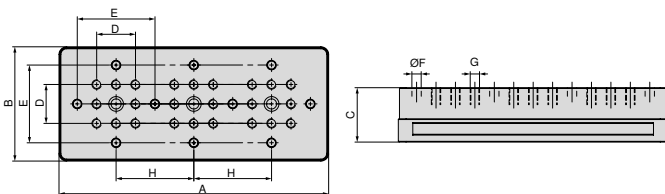

A	B	C	D	E _{±0,02}	F _{F7}	G	H	WT
mm	mm	mm	mm	mm	mm	M12	mm	kg
347	147	70	50	100	12	M12	100	9,3

80 899 ...

EUR
Y4

709,00 430

Vodnik po primežih

Pribor za sisteme

144+145 Splošni pribor

164–183

MNG – Konzola z vpenjalnim modulom z ničelno točko

▲ MNG – mehanski vpenjalni sistem z ničelno točko

MNG

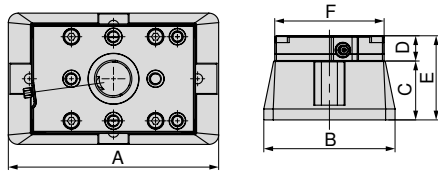

A	B	C	D	E	F
mm	mm	mm	mm	mm	mm
250	156	70	30	100	130

80 878 ...

EUR
Y4
1.300,00 54000

Konzola

▲ MNG – mehanski vpenjalni sistem z ničelno točko

ZSG
4

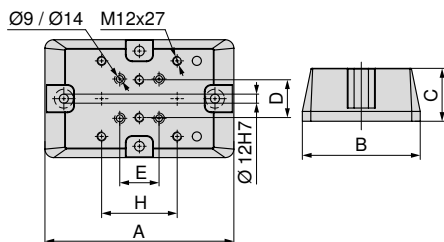

A	B	C	D	E	H	za
mm	mm	mm	mm	mm	mm	
250	156	70	50	52	100	ZSG 4 - 80 L = 130 mm + 190 mm / ZSG 4 - 125 L = 160 mm
320	197	100	50	50	100	ZSG 4 - 160 L = 280 mm
340	162	100	50	50	100	ZSG 4 - 125 L = 235 mm / 300 mm

80 878 ...

EUR
Y4
573,00 54100
903,00 54400
900,00 54300

MNG – Montažni komplet za konzolo

▲ MNG – mehanski vpenjalni sistem z ničelno točko



za
ZSG-4.125/160.L235-L280
ZSG-4.80.L130-L190

80 878 ...

EUR
Y4
11,30 54500
11,30 54200

Vodnik po primežih

Pribor za sisteme

144+145 Splošni pribor

164-183

MNG – Aluminijaste oblikovne vpenjalne stročnice

- ▲ MNG – mehanski vpenjalni sistem z ničelno točko
- ▲ za vgradnjo oblik za dvostransko obdelavo

Obseg dobave:

Vpenjalna stročnica z zatiči za pozicioniranje, brez priteznega čepa

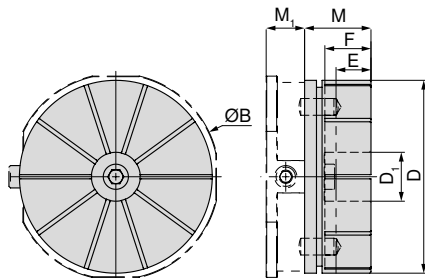

B	D	D ₁	E	F	M	M ₁
mm	mm	mm	mm	mm	mm	mm
148	138	35	22	33	47,5	27,5

80 899 ...

EUR
Y4

240,00 500

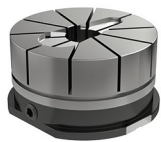

Aluminijasta vpenjalna
stročnica z obliko obdelovanca
na MNG, okrogla



Aluminijasta vpenjalna
stročnica z vpetim obdelovancem
na MNG, okrogla

Na voljo po naročilu



Paleta z luknjami



Paleta, neobdelana

 Največja globina rezkanja E znaša 22 mm

Nastavitveni prstan za MNG oblikovno vpenjalno stročnico

MNG



80 899 ...

EUR
Y4

58,30 510

Vodnik po primežih

Pribor za sisteme

144+145 Splošni pribor

164–183

MNG – Vpenjalni čep

▲ MNG – mehanski vpenjalni sistem z ničelno točko

Obseg dobave:

vkj. s pritrdilnimi vijaki

MNG

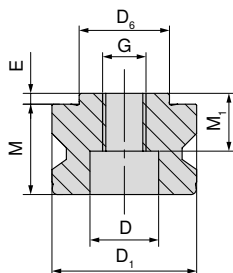

D ₆ h6	D ₁ h6	M	M ₁	E	D	G
mm	mm	mm	mm	mm	mm	
25	40	27	17	3	19	M12

80 899 ...

EUR
Y4

48,60 025

MNG – Zapiralni čep

▲ MNG – mehanski vpenjalni sistem z ničelno točko

MNG

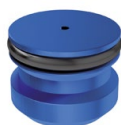

80 899 ...

EUR
Y4
14,30 040

D ₁
mm
40

MNG – Komplet cilindričnih zatičev

▲ MNG – mehanski vpenjalni sistem z ničelno točko

▲ za stolp ESG mini 4V in neposredno vpetje obdelovanca

▲ Cena za 2 kosa

MNG



80 899 ...

EUR
Y4

2,40 120

D ₁ m6	M
mm	mm
12	24

MNG – Mašilni čep s tesnilnim obročkom

▲ MNG – mehanski vpenjalni sistem z ničelno točko

MNG



80 899 ...

EUR
Y4
2,40 126

G
M12

MNG – Komplet zatičev za pozicioniranje

▲ MNG – mehanski vpenjalni sistem z ničelno točko

▲ za ESG mini in neposredno vpetje obdelovanca

▲ Cena za 2 kosa

MNG

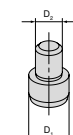

80 899 ...

EUR
Y4

34,70 128

Za širino	D ₁	D ₂
mm	mm	mm
65	12	8

MNG – Indeksirni zatič

▲ MNG – mehanski vpenjalni sistem z ničelno točko

MNG

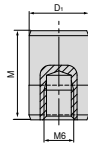

D ₁ mm	M mm
12	18

80 899 ...
EUR
Y4
17,30 51500

MNG – Komplet T-utornih vpenjalnih vijakov

▲ MNG – mehanski vpenjalni sistem z ničelno točko

Obseg dobave:

Vpenjalni vijak s T-utorno matico

MNG



Za širino utorov mm	G	EUR Y4	80 899 ...
12	M8	31,10	63800
12	M10	11,50	63400
14	M8	31,10	63900
14	M12	13,80	63500 ¹⁾
16	M8	31,10	64000
16	M12	13,80	63600 ¹⁾
18	M8	31,10	64100
18	M12	13,80	63700 ¹⁾

1) Z vijaki z nizko glavo

MNG – Vpenjalni komplet za T-utor 14 mm

▲ MNG – mehanski vpenjalni sistem z ničelno točko

▲ T-utorne matice so prilagojene za razdaljo med utori 63 mm

▲ Cena za 2 kosa

MNG



Za širino utorov mm	A mm
14	63

80 899 ...
EUR
Y4
96,10 614

MNG – Komplet za usmeritev in centriranje T-utorov

▲ MNG – mehanski vpenjalni sistem z ničelno točko

▲ A = razmak med utori

Obseg dobave:

1 vpenjalna letva, 2 utorni matice, 2 vijaka, 2 podložki za širino 12 mm, brez vpenjalne letve

MNG



A mm	Za širino utorov mm	EUR Y4	80 899 ...
50	12	71,30	012 ¹⁾
50	14	71,30	014
50	16	71,30	016
50	18	71,30	018
100	12	93,90	81200
100	14	93,90	81400
100	16	93,90	81600
100	18	93,90	81800

1) za širino 12 mm, brez vpenjalne letve

MNG – Okroglo vpenjalno orodje

▲ MNG – mehanski vpenjalni sistem z ničelno točko

▲ Komplet po 2 kosa

▲ Cena za 2 kosa

MNG



80 899 ...
EUR
Y4
81,00 300

MNG – Nadomestna vpenjalna enota

▲ MNG – mehanski vpenjalni sistem z ničelno točko

▲ 3-delni komplet

▲ Za okrogli MNG

MNG



80 899 ...
EUR
Y4
126,00 026

MNG

Možnost vpenjanja MNG

MNG – Osnovna plošča, pravokotna

Pritrditev:

- 2 x Vijaki z nizko glavo M12
- 1 x Komplet za usmeritev in centriranje

→ Stran 148
Tukaj boste našli ustrezne vijake.

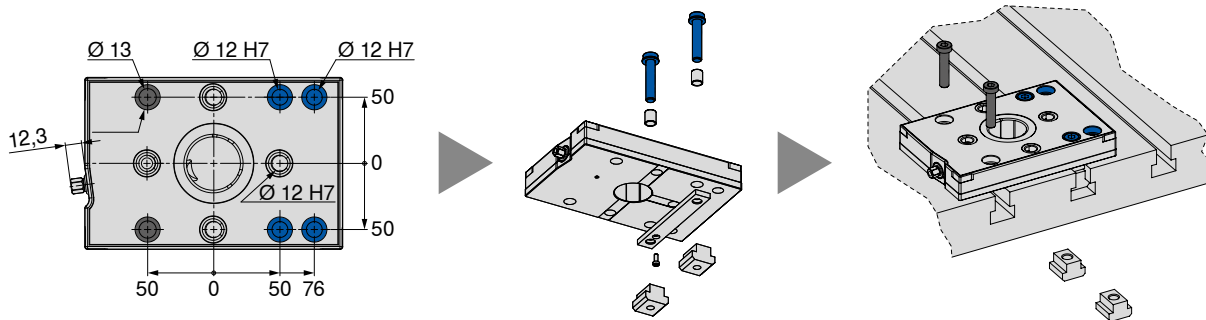

MNG – Osnovna plošča, pravokotna, 2-kratno

Pritrditev:

- 4 x Vijaki z nizko glavo M12
- 1 x Komplet za usmeritev in centriranje
- 4 x Posebni vijaki M8 MNG

→ Stran 148
Tukaj boste našli ustrezne vijake.

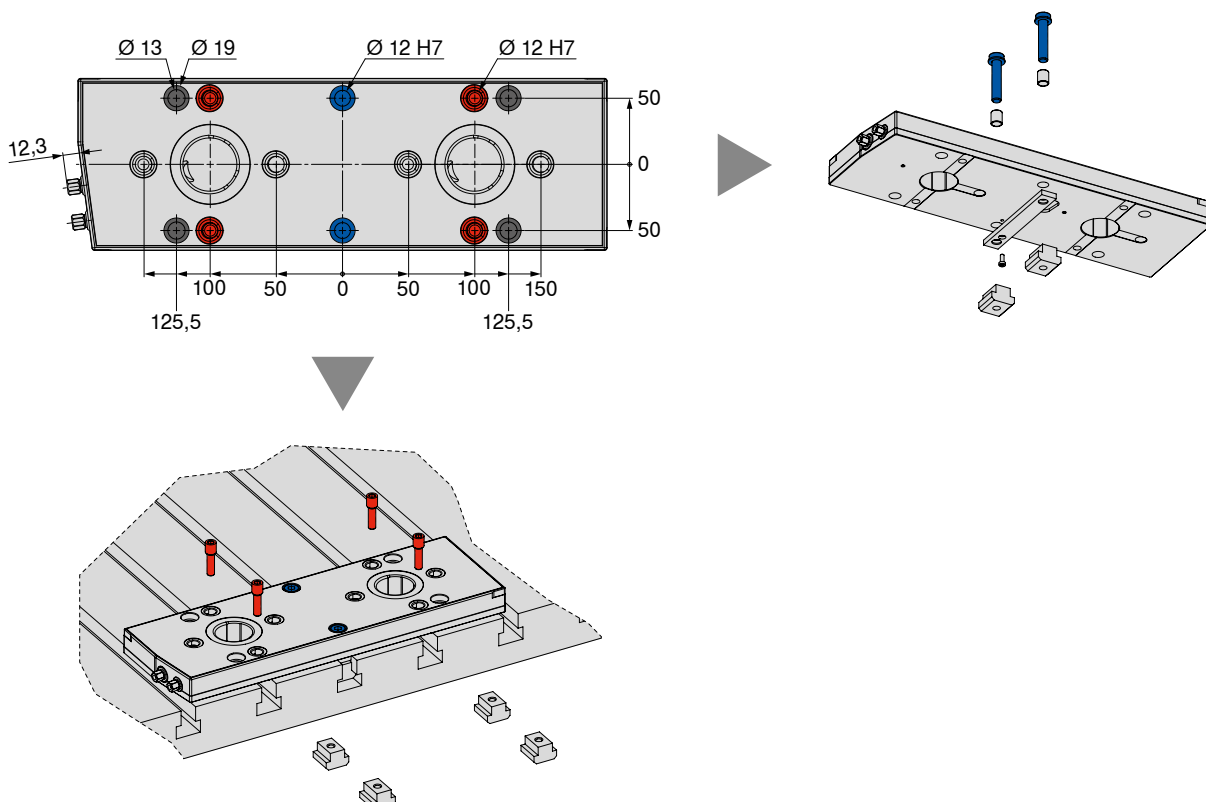

Možnost vpenjanja MNG

MNG – Osnovna plošča, pravokotna, 3-kratno

Pritrditev:

- 5 x Vijaki z nizko glavo M12
- 1 x Komplet za usmeritev in centriranje
- 5 x Posebni vijaki M8 MNG



→ Stran 148

Tukaj boste našli ustrezne vijake.

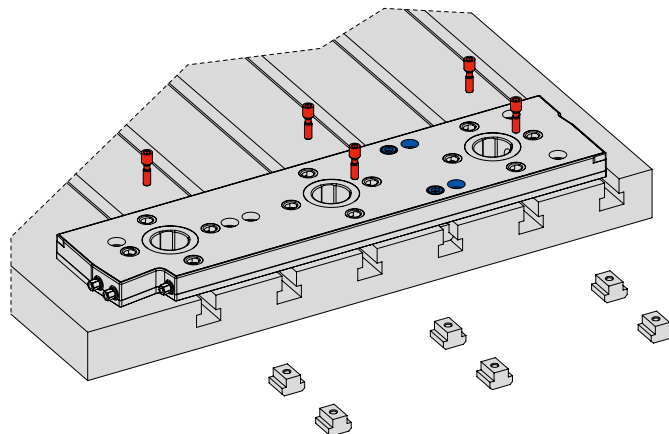
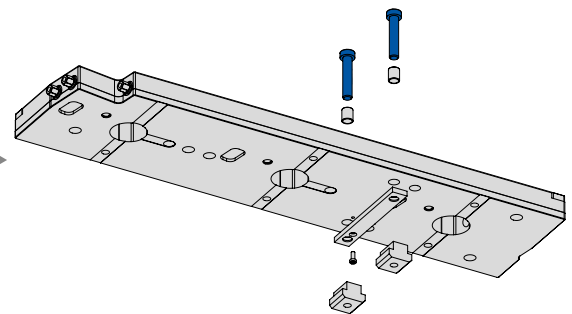
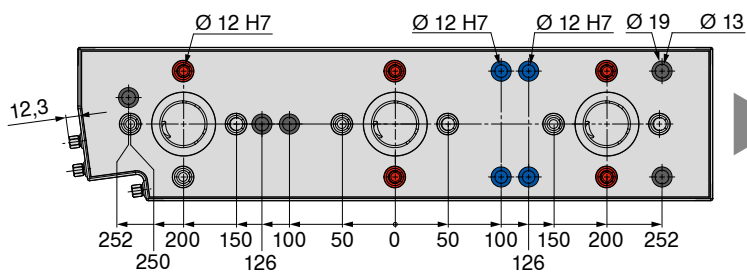

Možnost vpenjanja MNG

Miza s T-utorom – razdalja 126 mm/63 mm												
	12 mm			14 mm			16 mm			18 mm		
	●	●	●	●	●	●	●	●	●	●	●	●
	Komplet za usmeritev in centriranje, razdalja 100 mm 80 899 81200			Komplet za usmeritev in centriranje, razdalja 100 mm 80 899 81400			Komplet za usmeritev in centriranje, razdalja 100 mm 80 899 81600			Komplet za usmeritev in centriranje, razdalja 100 mm 80 899 81800		
	Vpenjalni komplet z vijaki z nizko glavo M10 80 899 63400			Vpenjalni komplet z vijaki z nizko glavo M12 80 899 63500			Vpenjalni komplet z vijaki z nizko glavo M12 80 899 63600			Vpenjalni komplet z vijaki z nizko glavo M12 80 899 63700		
	Vpenjalni komplet s posebnimi vijaki M8 MNG 80 899 63800			Vpenjalni komplet s posebnimi vijaki M8 MNG 80 899 63900			Vpenjalni komplet s posebnimi vijaki M8 MNG 80 899 64000			Vpenjalni komplet s posebnimi vijaki M8 MNG 80 899 64100		
MNG – Osnovna plošča, pravokotna	1 x	2 x	—	1 x	2 x	—	1 x	2 x	—	1 x	2 x	—
MNG – Osnovna plošča, pravokotna, 2-kratno	1 x	4 x	—	1 x	4 x	—	1 x	4 x	—	1 x	4 x	—
MNG – Osnovna plošča, pravokotna, 3-kratno	1 x	4 x	2 x	1 x	4 x	2 x	1 x	4 x	2 x	1 x	4 x	2 x

Miza s T-utorom – razdalja 100 mm/50 mm												
	12 mm			14 mm			16 mm			18 mm		
	●	●	●	●	●	●	●	●	●	●	●	●
	Komplet za usmeritev in centriranje, razdalja 100 mm 80 899 81200			Komplet za usmeritev in centriranje, razdalja 100 mm 80 899 81400			Komplet za usmeritev in centriranje, razdalja 100 mm 80 899 81600			Komplet za usmeritev in centriranje, razdalja 100 mm 80 899 81800		
	Vpenjalni komplet z vijaki z nizko glavo M10 80 899 63400			Vpenjalni komplet z vijaki z nizko glavo M12 80 899 63500			Vpenjalni komplet z vijaki z nizko glavo M12 80 899 63600			Vpenjalni komplet z vijaki z nizko glavo M12 80 899 63700		
	Vpenjalni komplet s posebnimi vijaki M8 MNG 80 899 63800			Vpenjalni komplet s posebnimi vijaki M8 MNG 80 899 63900			Vpenjalni komplet s posebnimi vijaki M8 MNG 80 899 64000			Vpenjalni komplet s posebnimi vijaki M8 MNG 80 899 64100		
MNG – Osnovna plošča, pravokotna	1 x	2 x	—	1 x	2 x	—	1 x	2 x	—	1 x	2 x	—
MNG – Osnovna plošča, pravokotna, 2-kratno	1 x	—	4 x	1 x	—	4 x	1 x	—	4 x	1 x	—	4 x
MNG – Osnovna plošča, pravokotna, 3-kratno	1 x	1 x	5 x	1 x	1 x	5 x	1 x	1 x	5 x	1 x	1 x	5 x

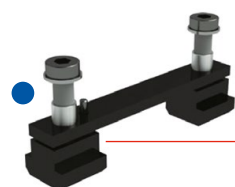

Komplet za usmeritev in centriranje, razdalja 100 mm

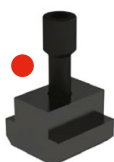

Vpenjalni komplet s posebnimi vijaki M8 MNG



Vpenjalni komplet z vijaki z nizko glavo M10 ali M12



Cilindrični vijak M16, samo osnovna plošča 6-krat, 400 x 400 mm



Cilindrični vijak za rastrske izvrtine M12



→ Stran 145

→ Stran 182+183

Tukaj boste našli zgoraj prikazane artikle.

MNG mini – Konzola

- ▲ z integriranim vpenjalnim sistemom z ničelno točko MNG mini
- ▲ Vpenjalne čepe naročite posebej
- ▲ Material: Aluminij, trdo anodiziran

**MNG
mini**

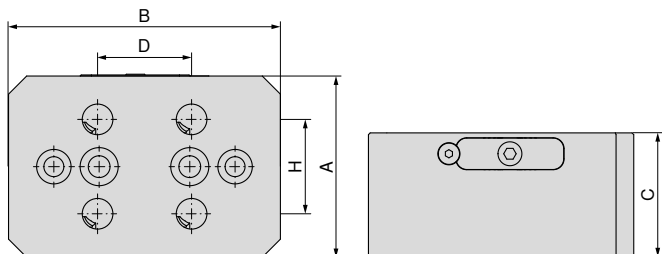

NEW

80 915 ...

EUR
Y4

770,00 57000

A	B	C	D	H
mm	mm	mm	mm	mm
100	150	70	52	52

MNG mini – 3-stranska piramida

- ▲ vključno z vpenjalnim sistemom z ničelno točko 3 x MNG mini
- ▲ Vpenjalne čepe naročite posebej
- ▲ Material: Aluminij, trdo anodiziran

**MNG
mini**

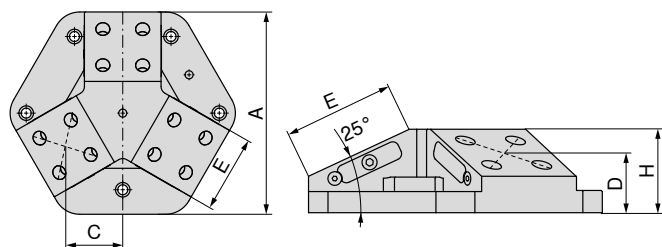

NEW

80 915 ...

EUR
Y4

1.980,00 58000

A	C	D	E	H
mm	mm	mm	mm	mm
264	86,68	53,87	100	75

 Primerno za: ESG 5 – 80 L-130 / ZSG 4 – 80 L-130 / ZSG mini – 70 L-80 / ZSG mini – 70 L-100

Mere spodnje strani za MNG mini

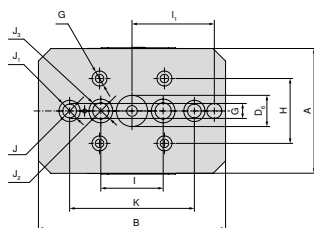

Konzola

A	B	D ₆ H7	G H7	H	I	I ₁ ±0,015	J	J ₁	J ₂	J ₃	K ±0,015
mm	mm	mm	mm	mm	mm	mm	mm	mm	mm	mm	mm
100	150	25	12	52	50	66	11	17	13	19	100

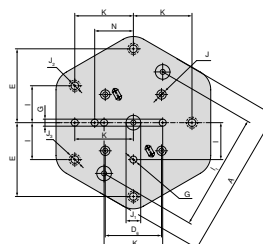

3-stranska piramida

A	D ₆ ±0,015	E	G H7	I	I ₁ ±0,015	J H7	J ₁ H7	J ₂	J ₃	K	N ±0,015
mm	mm	mm	mm	mm	mm	mm	mm	mm	mm	mm	mm
264	96	126	12	63	200	16	25	13	19	100	66

MNG mini – 4-stranska piramida

- ▲ vključno z vpenjalnim sistemom z ničelno točko 4 x MNG mini
- ▲ Vpenjalne čepe naročite posebej
- ▲ Material: Aluminij, trdo anodiziran

MNG mini

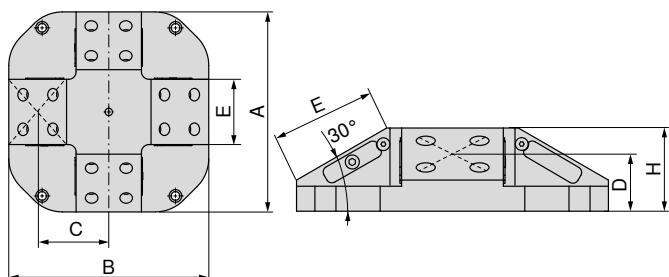

NEW

80 915 ...

EUR
Y4

2.390,00 57500

A	B	C	D	E	H
mm	mm	mm	mm	mm	mm
300	300	106,7	55	100	80

MNG mini – Trikotni vpenjalni stolp

- ▲ vključno z vpenjalnim sistemom z ničelno točko 3 x MNG mini
- ▲ Vpenjalne čepe naročite posebej
- ▲ Material: Aluminij, trdo anodiziran

MNG mini

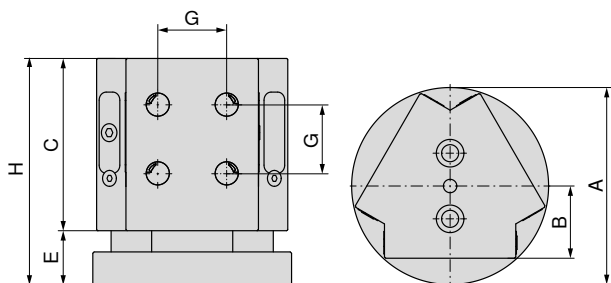

NEW

80 915 ...

EUR
Y4

1.490,00 51700

A	B	C	E	G	H
mm	mm	mm	mm	mm	mm
148	55	130	41	52	171

 Primerno za: ESG 5 – 80 L-130 / ZSG 4 – 80 L-130 / ZSG mini – 70 L-80 / ZSG mini – 70 L-100

Mere spodnje strani za MNG mini

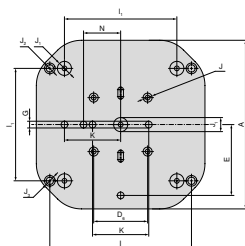

4-stranska piramida

A	D ₆ ±0.015	E	G _{H7}	I	I ₁ ±0.015	J _{H7}	J _{1H7}	J ₂	J ₃	K ±0.015	N ±0.015
mm	mm	mm	mm	mm	mm	mm	mm	mm	mm	mm	mm
300	96	126	12	252	200	16	25	13	19	100	66

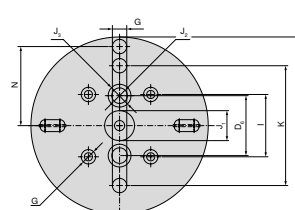

Trikotni vpenjalni stolp

A	D ₆	G _{H7}	I ±0.015	J _{1H7}	J ₂	J ₃	K ±0.015	N ±0.015
mm	mm	mm	mm	mm	mm	mm	mm	mm
148	50	12	52	25	13	19	100	66

Komplet vpenjalnih čepov MNG mini

Obseg dobave:

Komplet vsebuje štiri vpenjalne čepi

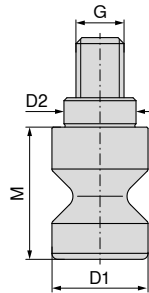
MNG
mini

NEW

80 915 ...

EUR
Y4

67,00 51600

D ₁ h6 mm	D ₂ h6 mm	M mm	G mm	TQX Nm	Držalna sila kN
16	12	22	M8	18	15

Komplet T-utornih vpenjalnih vijakov za MNG mini

Obseg dobave:

Vpenjalni vijak s T-utorno matico

MNG
mini

NEW

80 915 ...

EUR
Y416,70 61200
16,70 61400
17,90 61600
19,00 61800

Za širino utorov mm	G	EUR Y4	
12	M10	16,70	61200
14	M12	16,70	61400
16	M12	17,90	61600
18	M12	19,00	61800

Komplet za usmeritev in centriranje T-utorov

▲ MNG – mehanski vpenjalni sistem z ničelno točko

▲ A = razmak med utori

Obseg dobave:

1 vpenjalna letev, 2 utorni matici, 2 vijaka, 2 podložki za širino 12 mm, brez vpenjalne letve

MNG
mini

NEW

80 915 ...

EUR
Y490,70 81200
90,70 81400
90,70 81600
90,70 81800

A mm	Za širino utorov mm	EUR Y4	
100	12	90,70	81200
100	14	90,70	81400
100	16	90,70	81600
100	18	90,70	81800

PNG – Vpenjalna postaja, enkratna

- ▲ PNG – Pnevmatiski vpenjalni sistem z ničelno točko
- ▲ Vlečna sila 8 kN
- ▲ Vlečna sila s turbo 28 kN
- ▲ Sprostivni tlak 6 barov
- ▲ Priključek za zrak G 1/8

Obseg dobave:

Vpenjalna postaja, pritrdilne sponke, zapiralni nastavek, pnevmatski priključki, kapice za zaščito pred prahom, navodila za uporabo, brez vpenjalnega čepa, brez indeksirnega čepa

PNG

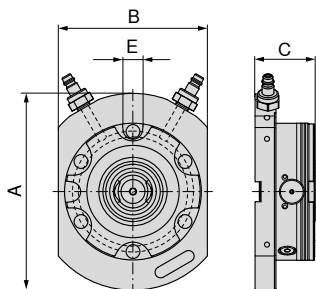

A	B	C	E _{H7}	WT
mm	mm	mm	mm	kg
198	150	60	20	7

80 809 ...

EUR
Y4

1.500,00 01100

PNG – Vpenjalna postaja, 2-kratna, 399 x 199 mm

- ▲ PNG – Pnevmatiski vpenjalni sistem z ničelno točko
- ▲ Vlečna sila 16 kN
- ▲ Sprostivni tlak 6 barov
- ▲ Priključek za zrak G 1/8

Obseg dobave:

Vpenjalna postaja, pritrdilne sponke, zapiralni nastavek, pnevmatski priključki, kapice za zaščito pred prahom, navodila za uporabo, brez vpenjalnega čepa, brez indeksirnega čepa

PNG

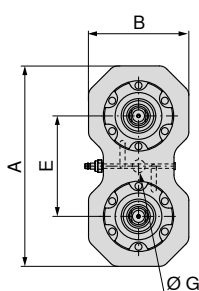

A	B	C	E	G _{H7}	WT
mm	mm	mm	mm	mm	kg
399	199	60	200	25	16,9

80 809 ...

EUR
Y4

2.400,00 02100

PNG – Vpenjalna postaja, 4-kratna, 399 x 399 mm

- ▲ PNG – Pnevmatiski vpenjalni sistem z ničelno točko
- ▲ Vlečna sila 32 kN
- ▲ Sprostivni tlak 6 barov
- ▲ Priključek za zrak G 1/8

Obseg dobave:

Vpenjalna postaja, pritrdilne sponke, zapiralni nastavek, pnevmatski priključki, kapice za zaščito pred prahom, navodila za uporabo, brez vpenjalnega čepa, brez indeksirnega čepa

PNG

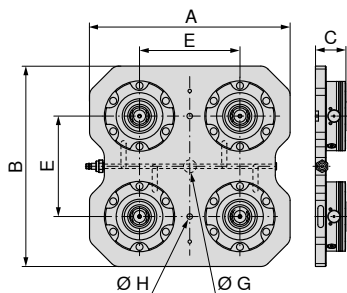

A	B	C	E	G _{H7}	H	WT
mm	mm	mm	mm	mm	mm	kg
399	399	60	200	25	11	35,7

80 809 ...

EUR
Y4

4.630,00 04100

PNG – Vpenjalna postaja, 6-kratna, 599 x 399 mm

- ▲ PNG – Pnevmatiski vpenjalni sistem z ničelno točko
- ▲ Vlečna sila 48 kN
- ▲ Sprostivni tlak 6 barov
- ▲ Priključek za zrak G 1/8

Obseg dobave:

Vpenjalna postaja, pritrdilne sponke, zapiralni nastavek, pnevmatski priključki, kapice za zaščito pred prahom, navodila za uporabo, brez vpenjalnega čepa, brez indeksirnega čepa

PNG

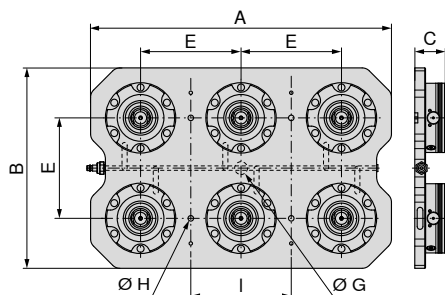

A	B	C	E	G _{H7}	H	I	WT
mm	mm	mm	mm	mm	mm	mm	kg
599	399	60	200	25	11	200	54,4

80 809 ...

EUR
Y4

6.240,00 06100

PNG – Vpenjalni modul z ničelno točko PNG.SM.138

- ▲ PNG – Pnevmski vpenjalni sistem z ničelno točko
- ▲ Vlečna sila 8 kN
- ▲ Vlečna sila s turbo 28 kN
- ▲ Sprostitveni tlak 6 barov
- ▲ Priključek za zrak G 1/8
- ▲ Natančnost ponovitve 0,005

Obseg dobave:

Vpenjalni modul, pritrilni vijaki, O-obroči, pokrivne kapice, navodila za uporabo, brez vpenjalnega čepa

PNG

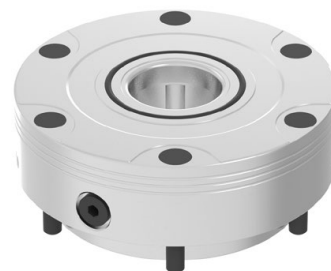
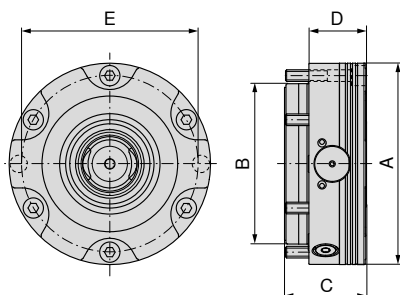

A	B	C	D	E	G	WT
mm	mm	mm	mm	mm		kg
138	110	55,7	39	121	G1/8"	4,4

80 809 ...

EUR

Y4

954,00 10100

PNG – Vpenjalni sistem z ničelno točko PNG.SM.T.138

- ▲ PNG – Pnevmski vpenjalni sistem z ničelno točko
- ▲ Vlečna sila 7 kN
- ▲ Vlečna sila s turbo 24 kN
- ▲ Sprostitveni tlak 6 barov
- ▲ Priključek za zrak G 1/8
- ▲ Natančnost ponovitve 0,005

Obseg dobave:

Vpenjalni modul, pritrilni vijaki, O-obroči, pokrivne kapice, navodila za uporabo, brez vpenjalnega čepa

PNG

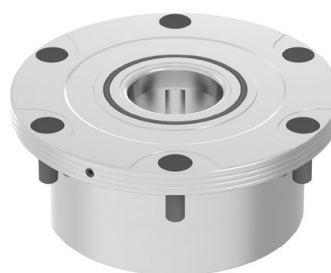
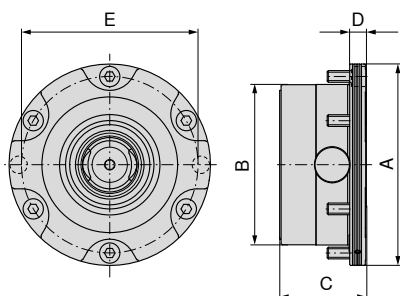

A	B	C	D	E	G	WT
mm	mm	mm	mm	mm		kg
138	110	59	11	121	G1/8"	3,5

80 809 ...

EUR

Y4

1.040,00 12100

PNG – Vpenjalni modul z ničelno točko PNG.SM.138

- ▲ PNG – Pnevmatiski vpenjalni sistem z ničelno točko
- ▲ Vlečna sila 8 kN
- ▲ Vlečna sila s turbo 28 kN
- ▲ Sprostitveni tlak 6 barov
- ▲ Priključek za zrak G 1/8
- ▲ Natančnost ponovitve 0,005

Obseg dobave:

Vpenjalni modul, pritrdilni vijaki, prilagodni vijak, O-obroči, pokrivne kapice, navodila za uporabo, brez vpenjalnega čepa, brez indeksirnega čepa

PNG

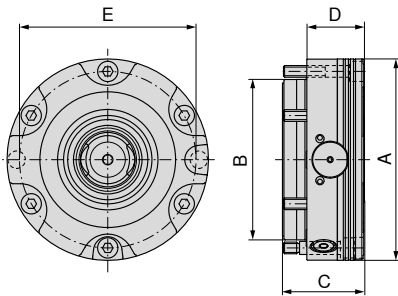

A	B	C	D	E	G	WT
mm	mm	mm	mm	mm		kg
138	110	55,7	39	121	G1/8"	4,4

80 809 ...

EUR
Y4

1.020,00 11100

PNG – Aluminijasta oblikovna vpenjalna stročnica

- ▲ PNG – Pnevmatiski vpenjalni sistem z ničelno točko
- ▲ Najv. vpenjalna sila 50 kN
- ▲ Natančnost ponovitve 0,005
- ▲ Vpenjalni hod 0,5 mm
- ▲ Material aluminij

Obseg dobave:

Aluminijasta oblikovna vpenjalna stročnica, nastavitveni prstan, vpenjalni čep, indeksirni čep, navodila za uporabo

PNG

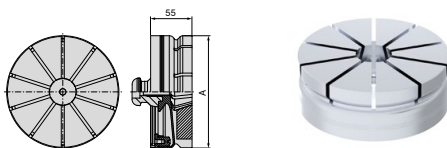

A	WT
mm	kg
149	1,5

80 809 ...

EUR
Y4

324,00 07600

PNG – Čep za indeksiranje

- ▲ PNG – Pnevmatiski vpenjalni sistem z ničelno točko

PNG

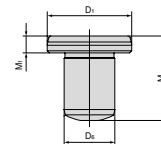

D ₁ h5	M	M ₁	D ₆ m6
mm	mm	mm	mm
20	20	4	12

80 809 ...

EUR
Y4

52,30 073

Montaža – vpenjalni čep

Obdelovanci ali naprave, ki jih je treba montirati, se namestijo in pritrdijo s tremi različnimi vpenjalnimi čepi:



Centrirni čep

Precizno brušeno, uporablja se za natančno določanje položaja vpenjalne naprave.



Čep za določanje položaja

Ta čep, imenovan tudi diamantni čep, se brusi samo v smeri osi za preprečitev preobremenitve sistema.



Vpenjalni čep

Zagotavlja, da palete plosko nalegajo na vpenjalni sistem; mogoče ga je močneje zbrusiti na kratkem konusu.

PNG – Vpenjalni čep

- ▲ PNG – Pnevmatični vpenjalni sistem z ničelno točko
- ▲ 3 vrste čepov – ZB (centrirni čep), PB (čep za določanje položaja), HB (nosilni čep)
- ▲ Izjemno natančna prilagoditev mer funkciji
- ▲ Držalna sila 50 kN

Obseg dobave:

vklij. s pritrdilnim vijakom M10

PNG

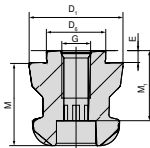

80 809 ...

Tip	D ₆ h6 mm	D ₁ h6 mm	M mm	M ₁ mm	E mm	G	EUR Y4	
ZB	25	40	35	27	5	M12	57,40	070
PB	25	40	35	27	5	M12	69,10	071
HB	25	40	35	27	5	M12	52,10	072

PNG – Konusno zapiralo

- ▲ PNG – Pnevmatični vpenjalni sistem z ničelno točko
- ▲ Zaščitni pokrov za zaščito vpenjalnega modula

PNG

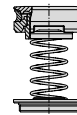

80 809 ...

WT
kg
0,11

EUR
Y4
121,00 07500

PNG – Zaščitni pokrov

- ▲ PNG – Pnevmatični vpenjalni sistem z ničelno točko
- ▲ Zaščitni pokrov za zaščito vpenjalnega modula

PNG

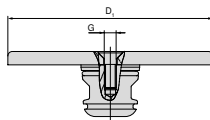

80 809 ...

D ₁ mm	G	EUR Y4	
138	M8	94,90	074

Pregled plošč z več adapterji



Paleta z več adapterji, 159 x 159 mm

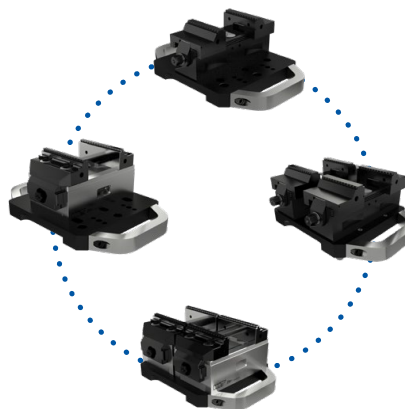

Primeri uporabe

Paleta z več adapterji, 159 x 159 mm

▲ Paleta z več adapterji za pritržitev na PNG in MNG

Obseg dobave:

Vklj. z vpenjalnim čepom in vpenjalnim vijakom

Brez prijemalnih nastavkov

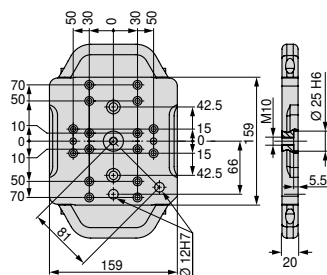

Velikost	WT
159x159 mm	4 kg

80 809 ...

EUR
Y4
502,00 500

Komplet za montažo – paleta z več adapterji 159 x 159 mm

▲ Cena za komplet



za
ZSG-4.80

80 878 ...

EUR
Y4
17,30 503

Pregled plošč z več adapterji



Paleta z več adapterji, 399 x 159 mm

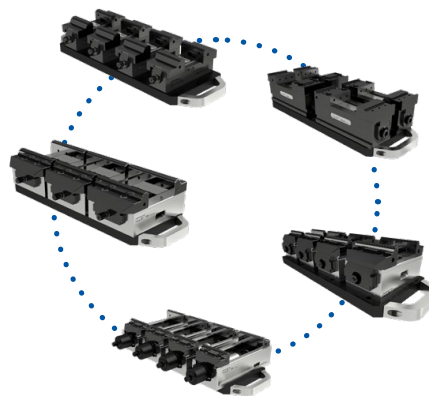

Primeri uporabe

Paleta z več adapterji, 399 x 159 mm

▲ Paleta z več adapterji za pritrnitev na PNG in MNG

Obseg dobave:

Vklj. z vpenjalnim čepom in vpenjalnim vijakom
Brez prijemalnih nastavkov

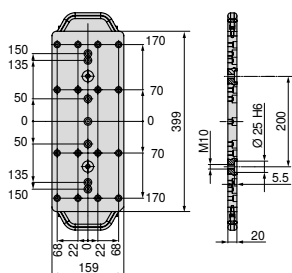

Velikost	WT
399x159 mm	10 kg

80 809 ...

EUR
Y4
737,00 501

Komplet za montažo – paleta z več adapterji 399 x 159 mm

▲ Cena za komplet



80 884 ...

EUR
Y4
39,00 503

za

ZSG-3.65/ZSG-4.80/125L160/ESG-4.80

Pregled plošč z več adapterji

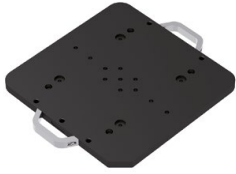

Paleta z več adapterji, 399 x 399 mm

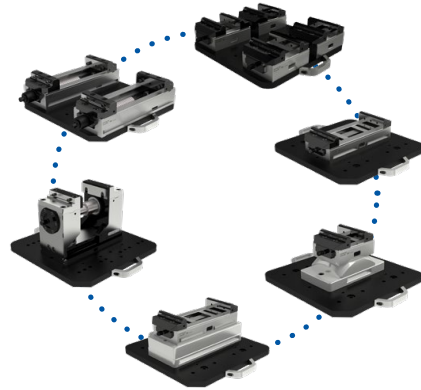

Primeri uporabe

Paleta z več adapterji, 399 x 399 mm

▲ Paleta z več adapterji za pritržitev na PNG in MNG

Obseg dobave:

Vklj. z vpenjalnim čepom in vpenjalnim vijakom
Brez prijemalnih nastavkov

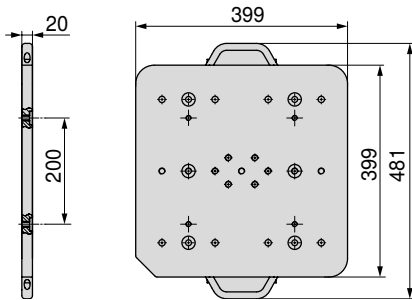

Velikost	WT
399x399 mm	25 kg

80 809 ...
EUR Y4
1.380,00 502

Kompet za montažo – paleta z več adapterji 399 x 399 mm

▲ Cena za komplet



za	80 901 ...	80 898 ...	80 878 ...
	EUR Y4	EUR Y4	EUR Y4
ESG4.125	55,10 500		
H5G.125		55,10 500	
ZSG-4.125.L160			17,30 500
ZSG-4.125.L160.K			55,10 502
ZSG-4.125.L300			55,10 501
ZSG-4.125.L300-DK			55,10 504

Vpenjalna paleta, jeklo, 159 x 159 mm

▲ Vpenjalna paleta za pritrditev na PNG

▲ brez slike izvrtine

Obseg dobave:

neobdelana vpenjalna paleta, vpenjalni čep PNG in zatič za pozicioniranje

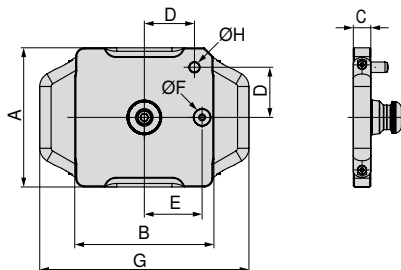

Velikost	A	B	C	D	E	F _{H5}	G	H _{m6}	WT
	mm	mm	mm	mm	mm	mm	mm	mm	kg
159x159 mm	159	159	20	58	66	20	239	12	4,2

80 809 ...

EUR
Y4

333,00 080

Vpenjalna paleta, aluminij, 159 x 159 mm

▲ Vpenjalna paleta za pritrditev na PNG

▲ Brez slike izvrtine

Obseg dobave:

neobdelana vpenjalna paleta, vpenjalni čep PNG in zatič za pozicioniranje

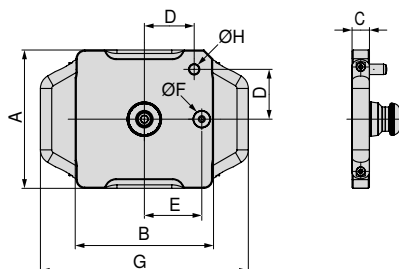

Velikost	A	B	C	D	E	F _{H5}	G	H _{m6}	WT
	mm	mm	mm	mm	mm	mm	mm	mm	kg
159x159 mm	159	159	25	58	66	20	239	12	2,2

80 809 ...

EUR
Y4

376,00 081

Vpenjalna paleta, jeklo, 399 x 159 mm

▲ Vpenjalna paleta za pritrditev na PNG in MNG

▲ Brez slike izvrtine

Obseg dobave:

neobdelana vpenjalna paleta, vpenjalni čep PNG in zatič za pozicioniranje

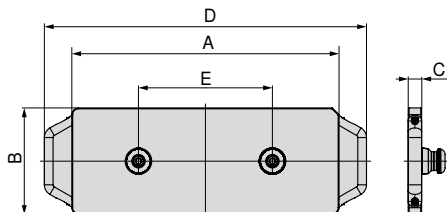

Velikost	A mm	B mm	C mm	D mm	E mm	WT kg
399x159 mm	399	159	20	481	200	10,6

80 809 ...

EUR
Y4

668,00 082

Vpenjalna paleta, aluminij, 399 x 159 mm

▲ Vpenjalna paleta za pritrditev na PNG in MNG

▲ Brez slike izvrtine

Obseg dobave:

neobdelana vpenjalna paleta, vpenjalni čep PNG in zatič za pozicioniranje

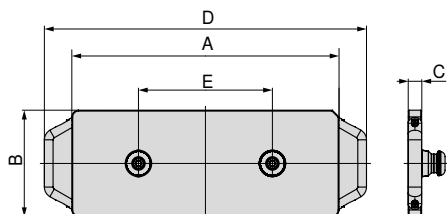

Velikost	A mm	B mm	C mm	D mm	E mm	WT kg
399x159 mm	399	159	25	481	200	5,1

80 809 ...

EUR
Y4

584,00 083

Vpenjalna paleta, jeklo, 399 x 399 mm

▲ Vpenjalna paleta za pritrditev na PNG in MNG

▲ Brez slike izvrtine

Obseg dobave:

neobdelana vpenjalna paleta, vpenjalni čep PNG in zatič za pozicioniranje

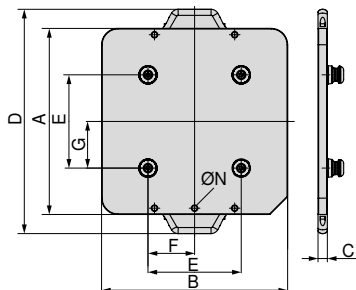

Velikost	A	B	C	D	E	F	G	N	WT
	mm	mm	mm	mm	mm	mm	mm	M10	kg
399x399 mm	399	399	20	481	200	100	100	M10	28

80 809 ...

EUR
Y4

1.460,00 084

Vpenjalna paleta, aluminij, 399 x 399 mm

▲ Vpenjalna paleta za pritrditev na PNG in MNG

▲ Brez slike izvrtine

Obseg dobave:

neobdelana vpenjalna paleta, vpenjalni čep PNG in zatič za pozicioniranje

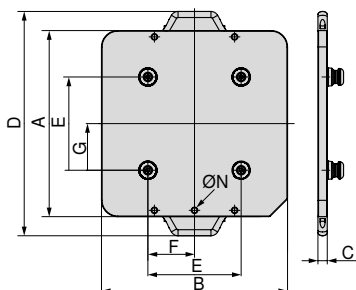

Velikost	A	B	C	D	E	F	G	N	WT
	mm	mm	mm	mm	mm	mm	mm	M10	kg
399x399 mm	399	399	25	481	200	100	100	M10	12

80 809 ...

EUR
Y4

1.070,00 085

Vpenjalna paleta, jeklo, 599 x 159 mm

- ▲ Vpenjalna paleta za pritrditev na PNG in MNG
- ▲ Brez slike izvrtine

Obseg dobave:

neobdelana vpenjalna paleta, vpenjalni čep PNG in zatič za pozicioniranje

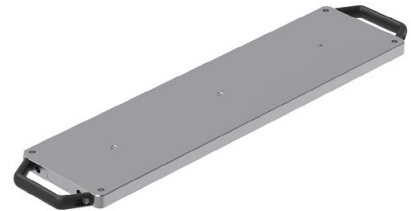
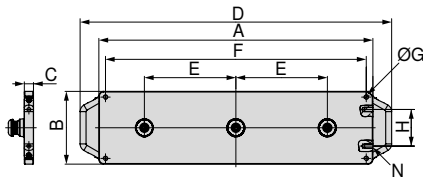

Velikost	A	B	C	D	E	F	G	H	N	WT
	mm	mm	mm	mm	mm	mm		mm		kg
599x159 mm	599	159	20	681	200	570	M10	80	M10	15,6

80 809 ...

EUR
Y4

936,00 086

Vpenjalna paleta, aluminij, 599 x 159 mm

- ▲ Vpenjalna paleta za pritrditev na PNG in MNG
- ▲ Brez slike izvrtine

Obseg dobave:

neobdelana vpenjalna paleta, vpenjalni čep PNG in zatič za pozicioniranje

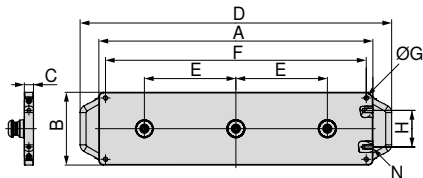

Velikost	A	B	C	D	E	F	G	H	N	WT
	mm	mm	mm	mm	mm	mm		mm		kg
599x159 mm	599	159	25	681	200	570	M10	80	M10	7,4

80 809 ...

EUR
Y4

1.020,00 087

Pregled splošnih čeljustnih nastavkov

6-delni čeljustni nastavek

- ▲ 1 = Gladka, prevlečena z volframovim karbidom
- ▲ 2 = Prijemalo s stopnico 3 mm
- ▲ 3 = Prijemalo s stopnico 8 mm
- ▲ 4 = Prijemalo s stopnico 18 mm
- ▲ 5 = Prijemalo, okroglo, s stopnico 8 mm
- ▲ 6 = Prijemalo, okroglo
- ▲ $M_{najv.} = 60 \text{ Nm}$
- ▲ Vklj. s pritrdilnimi vijaki

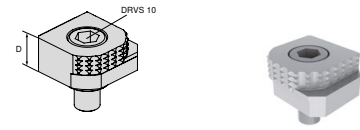

Za širino primeža	A	A ₁	D	D ₁	D ₂	E	M	M ₁	M ₂	EUR	Y4	NCG	H5G / -S / -Z	X5G-Z / -S	ESG 4	ESG 5	HDG 2	ZSG 4	ZSG mini	DSG 4	Verso	HSG	
			18							80,60	80 892 246	●	●	●	●				●	●	●	●	

6-delni čeljustni nastavek, s prijemalom iz karbidne trdine

- ▲ 1 = gladka
- ▲ 2 = karbidno prijemalo
- ▲ 3 = karbidno prijemalo s stopnico 3 mm
- ▲ 4 = karbidno prijemalo s stopnico 8 mm
- ▲ 5 = karbidno prijemalo, okroglo, s stopnico 8 mm
- ▲ 6 = karbidno prijemalo, okroglo
- ▲ vklj. s pritrdilnimi vijaki

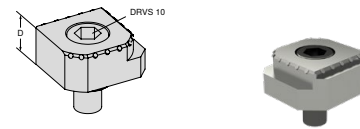

Za širino primeža	A	A ₁	D	D ₁	D ₂	E	M	M ₁	M ₂	EUR	Y4	NCG	H5G / -S / -Z	X5G-Z / -S	ESG 4	ESG 5	HDG 2	ZSG 4	ZSG mini	DSG 4	Verso	HSG	
			18							117,00	80 890 35300	●	●	●	●				●	●	●	●	

Letev za določanje položaja

- ▲ za stopničaste čeljusti s T-utorom
- ▲ Različne vpenjalne globine dosežemo z rezkanjem
- ▲ Uporaba z rezkanjem prečke kot omejevalne letve
- ▲ Po potrebi možnost naknadnega kaljenja za material 1.7131
- ▲ Cena za kos

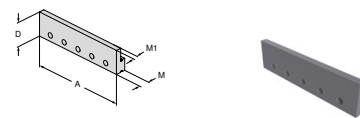

Za širino primeža	A	A ₁	D	D ₁	D ₂	E	M	M ₁	M ₂	EUR	Y4	NCG	H5G / -S / -Z	X5G-Z / -S	ESG 4	ESG 5	HDG 2	ZSG 4	ZSG mini	DSG 4	Verso	HSG	
	100		32				13,5	7		48,90	80 892 338	●						●					●
	125		32				13,5	7		51,30	80 892 339	●	●					●	●		●		●
	160		32				13,5	7		49,70	80 892 340	●						●					●

Pregled splošnih čeljustnih nastavkov

Stopničasta čeljust, prijemalo s T-utorom

- ▲ T-utor za vpenjanje letve za določanje položaja
- ▲ S 6,5 mm široko nosilno površino je dobro primeren za obdelovance z grobimi robovi
- ▲ Z laserjem označene razdelitve (2 mm) kot pomoč pri določanju položaja
- ▲ Cena za kos

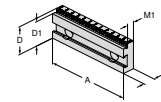

Za širino primeža	A	A ₁	D	D ₁	D ₂	E	M	M ₁	M ₂	EUR	Y4	NCG	H5G / -S / -Z	X5G-Z / -S	ESG 4	ESG 5	HDG 2	ZSG 4	ZSG mini	DSG 4	Verso	HSG	
100			35	32			17,5	11,5		131,00	80 892 341	●					●						●
100			35	30			17,5	11,5		131,00	80 892 342	●					●						●
100			35	27			17,5	11,5		131,00	80 892 343	●					●						●
125			40	37			17,5	11,5		142,00	80 892 344	●	●		●		●	●			●		●
125			40	35			17,5	11,5		141,00	80 892 345	●	●		●		●	●			●		●
125			40	32			17,5	11,5		141,00	80 892 346	●	●		●		●	●			●		●
160			50	45			20	13,5		158,00	80 892 348	●			●		●	●			●		●
160			50	42			20	13,5		158,00	80 892 349	●			●		●	●			●		●

Stopničasta čeljust, gladka

- ▲ Cena za kos

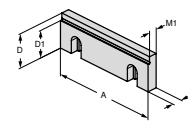

Za širino primeža	A	A ₁	D	D ₁	D ₂	E	M	M ₁	M ₂	EUR	Y4	NCG	H5G / -S / -Z	X5G-Z / -S	ESG 4	ESG 5	HDG 2	ZSG 4	ZSG mini	DSG 4	Verso	HSG	
100			35	30			10	7,5		86,40	80 892 21400	●					●						●
125			40	32			11,5	9,5		103,00	80 892 21500	●	●		●		●	●			●		●
160			50	42			13,5	10,5		186,00	80 892 21600	●			●		●	●			●		●

Stopničasta čeljust, gladka

- ▲ Možnost uporabe kot gladka čeljust ali stopničasta čeljust
- ▲ Čeljust je v celoti kaljena in brušena
- ▲ Cena za kos

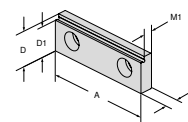

Za širino primeža	A	A ₁	D	D ₁	D ₂	E	M	M ₁	M ₂	EUR	Y4	NCG	H5G / -S / -Z	X5G-Z / -S	ESG 4	ESG 5	HDG 2	ZSG 4	ZSG mini	DSG 4	Verso	HSG	
65			22	19			8	5,5		72,40	80 895 332	●											

Stopničasta čeljust, prevlečena, 5 mm

- ▲ Cena za kos

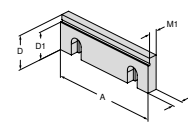

Za širino primeža	A	A ₁	D	D ₁	D ₂	E	M	M ₁	M ₂	EUR	Y4	NCG	H5G / -S / -Z	X5G-Z / -S	ESG 4	ESG 5	HDG 2	ZSG 4	ZSG mini	DSG 4	Verso	HSG	
80			28	23			10	7,5		156,00	80 878 31400				●			●		●			

Pregled splošnih čeljustnih nastavkov

Stopničasta čeljust, prevlečena, 5 mm

▲ Cena za kos

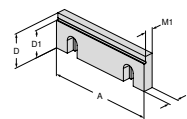

Za širino primeža	A	A ₁	D	D ₁	D ₂	E	M	M ₁	M ₂	EUR	Y4	NCG	H5G / -S / -Z	X5G-Z / -S	ESG 4	ESG 5	HDG 2	ZSG 4	ZSG mini	DSG 4	Verso	HSG	
100			35	30			10	7,5		171,00	80 892 36300	●					●						
125			40	35			11,5	9,5		151,00	80 892 250	●	●		●		●				●		●
160			50	45			13,5	10,5		213,00	80 892 36400	●			●		●						●

Stopničasta čeljust, 5 mm

▲ Cena za kos

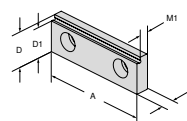

Za širino primeža	A	A ₁	D	D ₁	D ₂	E	M	M ₁	M ₂	EUR	Y4	NCG	H5G / -S / -Z	X5G-Z / -S	ESG 4	ESG 5	HDG 2	ZSG 4	ZSG mini	DSG 4	Verso	HSG	
80			28	23			10	7,5		128,00	80 878 830				●				●		●		

Stopničasta čeljust, prijemalna

▲ Cena za kos

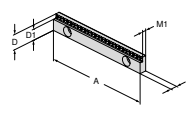

Za širino primeža	A	A ₁	D	D ₁	D ₂	E	M	M ₁	M ₂	EUR	Y4	NCG	H5G / -S / -Z	X5G-Z / -S	ESG 4	ESG 5	HDG 2	ZSG 4	ZSG mini	DSG 4	Verso	HSG	
125			18	13			8	5,5		135,00	80 898 252		●		●						●		
125			18	15			8	5,5		135,00	80 898 250		●		●						●		

Stopničasta čeljust, prijemalna, 3 mm

▲ Cena za kos

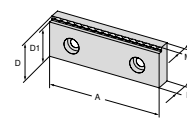

Za širino primeža	A	A ₁	D	D ₁	D ₂	E	M	M ₁	M ₂	EUR	Y4	NCG	H5G / -S / -Z	X5G-Z / -S	ESG 4	ESG 5	HDG 2	ZSG 4	ZSG mini	DSG 4	Verso	HSG	
80			28	25			10	7		91,70	80 906 30900				●				●		●		

Pregled splošnih čeljustnih nastavkov

Stopničasta čeljust, prijemalna, 3, 5 in 8 mm

▲ Cena za kos

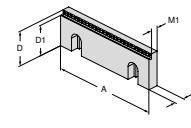

Za širino primeža	A	A ₁	D	D ₁	D ₂	E	M	M ₁	M ₂	EUR	Y4	NCG	H5G / -S / -Z	X5G-Z / -S	ESG 4	ESG 5	HDG 2	ZSG 4	ZSG mini	DSG 4	Verso	HSG
100			35	27			10	7,5		108,00	80 892 29200	●					●					●
100			35	30			10	7,5		108,00	80 892 29000	●					●					●
100			35	32			10	7,5		108,00	80 892 29400	●					●					●
125			40	32			11,5	9		124,00	80 892 29300	●	●		●		●	●		●		●
125			40	35			11,5	9		124,00	80 892 29100	●	●		●		●	●		●		●
125			40	37			11,5	9		124,00	80 892 29500	●	●		●		●	●		●		●
160			50	42			13,5	11		138,00	80 892 29900	●	●		●		●	●		●		●
160			50	45			13,5	11		138,00	80 892 29800	●	●		●		●	●		●		●
160			50	47			13,5	11		138,00	80 892 29700	●	●		●		●	●		●		●

Stopničasta čeljust, karbidno prijemalo 3 mm

▲ Cena za kos

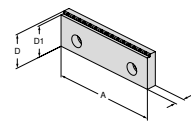

Za širino primeža	A	A ₁	D	D ₁	D ₂	E	M	M ₁	M ₂	EUR	Y4	NCG	H5G / -S / -Z	X5G-Z / -S	ESG 4	ESG 5	HDG 2	ZSG 4	ZSG mini	DSG 4	Verso	HSG
100			35	32			7,5			156,00	80 892 37600	●	●		●		●	●		●		●
125			40	37			11,5			171,00	80 892 36500	●	●		●		●	●		●		●
160			50	47			13,5			195,00	80 892 37400	●	●		●		●	●		●		●

Stopničasta čeljust, karbidno prijemalo 5 mm

▲ Cena za kos

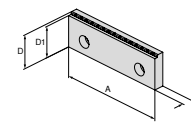

Za širino primeža	A	A ₁	D	D ₁	D ₂	E	M	M ₁	M ₂	EUR	Y4	NCG	H5G / -S / -Z	X5G-Z / -S	ESG 4	ESG 5	HDG 2	ZSG 4	ZSG mini	DSG 4	Verso	HSG
100			35	30			12			156,00	80 892 37700	●	●		●		●	●		●		●
125			40	35			13,5			171,00	80 892 37500	●	●		●		●	●		●		●
160			50	45			15,5			195,00	80 892 37300	●	●		●		●	●		●		●

Stopničasta čeljust, 18 mm s stopnjo 3 mm

▲ Cena za kos

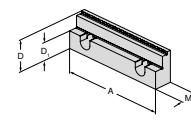

Za širino primeža	A	A ₁	D	D ₁	D ₂	E	M	M ₁	M ₂	EUR	Y4	NCG	H5G / -S / -Z	X5G-Z / -S	ESG 4	ESG 5	HDG 2	ZSG 4	ZSG mini	DSG 4	Verso	HSG
125			40	22			21,5			222,00	80 892 288	●	●		●		●	●		●		●

Pregled splošnih čeljustnih nastavkov

Stopničasta čeljust, 18 mm s stopnjo 3 mm

▲ Cena za kos

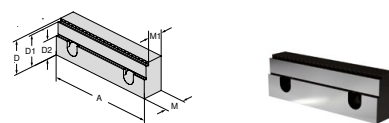

Za širino primeža	A	A ₁	D	D ₁	D ₂	E	M	M ₁	M ₂
	125		40	37	22		24	19	

EUR 235,00

Y4

80 907 302	•	•	•	•	•	•	•	•	•
------------	---	---	---	---	---	---	---	---	---

Stopničasta čeljust, prijemalo 5 mm za aluminij in umetno maso

▲ Cena za kos

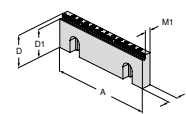

Za širino primeža	A	A ₁	D	D ₁	D ₂	E	M	M ₁	M ₂
	125		40	35			11,5	8	

EUR 143,00

Y4

80 892 36100	•	•	•	•	•	•	•	•	•
--------------	---	---	---	---	---	---	---	---	---

Reliefni profil stopničaste čeljusti

▲ Cena za kos

▲ Primerna za LANG-ov predodtisnjeni reliefni profil

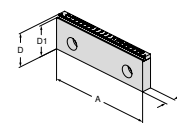

Za širino primeža	A	A ₁	D	D ₁	D ₂	E	M	M ₁	M ₂
	125		40	37			11,5		

EUR 138,00

Y4

80 892 36200	•	•	•	•	•	•	•	•	•
--------------	---	---	---	---	---	---	---	---	---

Čeljust, prijemalna

▲ Cena za kos

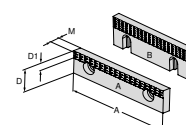

Slika	A	A ₁	D	D ₁	D ₂	E	M	M ₁	M ₂
A	40		22	7			7,8		
A	65		22	7			7,8		
A	90		22	7			7,8		
B	100		35	12			10		
B	125		40	14,5			11,5		
B	160		50	14,5			13,5		

EUR

Y4

80 892 279									
80 892 280									
80 892 284									
80 892 21700	•						•		•
80 892 21800	•						•		•
80 892 21900	•						•		•

Pregled splošnih čeljustnih nastavkov

Čeljustni nastavek, prijemalni

▲ Cena za kos

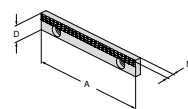

Za širino primeža	A	A ₁	D	D ₁	D ₂	E	M	M ₁	M ₂	EUR	Y4	NCG	H5G / -S / -Z	X5G-Z / -S	ESG 4	ESG 5	HDG 2	ZSG 4	ZSG mini	DSG 4	Verso	HSG	
	125		18				7,8			66,90	80 898 253	●	●	●						●			

Čeljustni nastavek, brušen

▲ Cena za kos

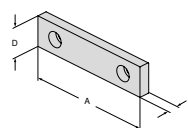

Za širino primeža	A	A ₁	D	D ₁	D ₂	E	M	M ₁	M ₂	EUR	Y4	NCG	H5G / -S / -Z	X5G-Z / -S	ESG 4	ESG 5	HDG 2	ZSG 4	ZSG mini	DSG 4	Verso	HSG		
	40		22				7,7			33,50	80 889 401											●		
	40		35				10			37,80	80 889 405												●	
	65		22				7,7			37,80	80 889 651												●	
	65		35				10			41,00	80 889 655												●	
	90		22				7,7			41,00	80 889 901												●	
	90		35				10			49,70	80 889 905												●	

Čeljustni nastavek, brušen

▲ Cena za kos

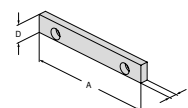

Za širino primeža	A	A ₁	D	D ₁	D ₂	E	M	M ₁	M ₂	EUR	Y4	NCG	H5G / -S / -Z	X5G-Z / -S	ESG 4	ESG 5	HDG 2	ZSG 4	ZSG mini	DSG 4	Verso	HSG	
	125		18				7,6			50,80	80 898 251	●	●	●							●		

Čeljustni nastavek, prevlečen z WC

▲ s prevleko iz volframovega karbida

▲ Cena za kos

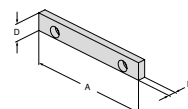

Za širino primeža	A	A ₁	D	D ₁	D ₂	E	M	M ₁	M ₂	EUR	Y4	NCG	H5G / -S / -Z	X5G-Z / -S	ESG 4	ESG 5	HDG 2	ZSG 4	ZSG mini	DSG 4	Verso	HSG	
	125		18				7,6			102,00	80 898 254	●	●	●							●		

Pregled splošnih čeljustnih nastavkov

Vpenjalna čeljust, gladka

▲ Cena za kos

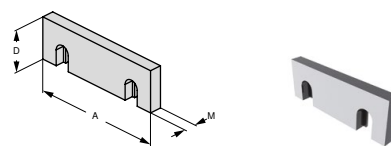

Za širino primeža	A	A ₁	D	D ₁	D ₂	E	M	M ₁	M ₂	EUR	Y4	NCG	H5G / -S / -Z	X5G-Z / -S	ESG 4	ESG 5	HDC 2	ZSG 4	ZSG mini	DSG 4	Verso	HSG	
100			35				10			40,00	80 892 20400	●					●					●	
125			40				11,5			48,60	80 892 20500	●			●		●				●		●
160			50				13,5			74,70	80 892 20600	●			●		●	●					●

Vpenjalna čeljust, profilirana

▲ Cena za kos

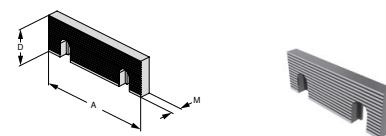

Za širino primeža	A	A ₁	D	D ₁	D ₂	E	M	M ₁	M ₂	EUR	Y4	NCG	H5G / -S / -Z	X5G-Z / -S	ESG 4	ESG 5	HDC 2	ZSG 4	ZSG mini	DSG 4	Verso	HSG	
100			35				10			45,40	80 892 20700	●					●					●	
125			40				11,5			55,10	80 892 20800	●			●		●	●			●		●
160			50				13,5			90,60	80 892 20900	●			●		●	●					●

Prijemalna čeljust, obrnljiva

▲ za vertikalno in horizontalno uporabo

▲ Cena za kos

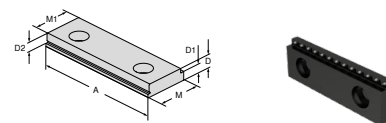

Za širino primeža	A	A ₁	D	D ₁	D ₂	E	M	M ₁	M ₂	EUR	Y4	NCG	H5G / -S / -Z	X5G-Z / -S	ESG 4	ESG 5	HDC 2	ZSG 4	ZSG mini	DSG 4	Verso	HSG	
65			8	5,5	5		22	19		36,80	80 895 340	●	●										
100			10,5	8	5		35	32		51,90	80 895 343	●	●				●						●

Prijemalna čeljust, obrnljiva

▲ za vertikalno in horizontalno uporabo

▲ 3-točkovno vpenjanje

▲ Cena za kos

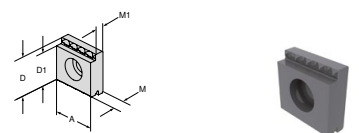

Za širino primeža	A	A ₁	D	D ₁	D ₂	E	M	M ₁	M ₂	EUR	Y4	NCG	H5G / -S / -Z	X5G-Z / -S	ESG 4	ESG 5	HDC 2	ZSG 4	ZSG mini	DSG 4	Verso	HSG	
65	22		22	19			8	5,5		19,50	80 895 335	●	●					●					
100	35		35	32			10,5	8		31,40	80 895 345	●	●				●						

Pregled splošnih čeljustnih nastavkov

Čeljust, z nasekom

▲ Cena za kos

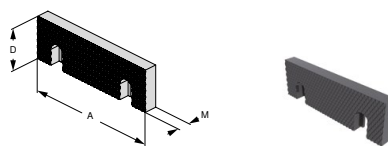

Za širino primeža	A	A ₁	D	D ₁	D ₂	E	M	M ₁	M ₂	EUR	Y4	NCG	H5G / -S / -Z	X5G-Z / -S	ESG 4	ESG 5	HDG 2	ZSG 4	ZSG mini	DSG 4	Verso	HSG	
100			35				11			54,00	80 892 20100	●					●						●
125			40				12,5			65,90	80 892 20200	●			●		●				●		●
160			50				14,5			76,60	80 892 20300	●			●		●	●					●

Čeljust, z nasekom

▲ Cena za kos

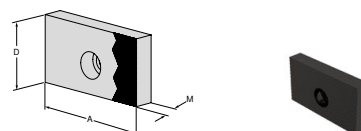

Za širino primeža	A	A ₁	D	D ₁	D ₂	E	M	M ₁	M ₂	EUR	Y4	NCG	H5G / -S / -Z	X5G-Z / -S	ESG 4	ESG 5	HDG 2	ZSG 4	ZSG mini	DSG 4	Verso	HSG		
40			35				11			37,80	80 889 408											●		
40			22				8			33,50	80 889 404												●	
65			35				11			41,00	80 889 658												●	
65			22				8			37,80	80 889 654												●	
90			35				11			49,70	80 889 908												●	
90			22				8			41,00	80 889 904												●	

Čeljusti v mehki izvedbi, jeklo

- ▲ Material: 16MnCr5
- ▲ Samo za vertikalno uporabo
- ▲ Cena za kos

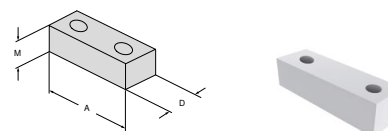

Za širino primeža	A	A ₁	D	D ₁	D ₂	E	M	M ₁	M ₂	EUR	Y4	NCG	H5G / -S / -Z	X5G-Z / -S	ESG 4	ESG 5	HDG 2	ZSG 4	ZSG mini	DSG 4	Verso	HSG		
40			22				20			33,50	80 895 244											●		
65			22				20			37,80	80 895 245		●		●				●				●	
90			22				20			41,00	80 895 246												●	

Čeljusti v mehki izvedbi, jeklo

- ▲ Material: 14NiCr14
- ▲ za izdelavo oblikovnih čeljusti
- ▲ Cena za kos

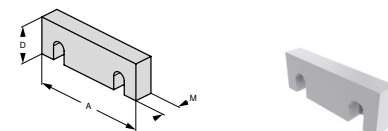

Za širino primeža	A	A ₁	D	D ₁	D ₂	E	M	M ₁	M ₂	EUR	Y4	NCG	H5G / -S / -Z	X5G-Z / -S	ESG 4	ESG 5	HDG 2	ZSG 4	ZSG mini	DSG 4	Verso	HSG	
100			35				16			43,20	80 892 24700	●						●					●
125			40				20			50,80	80 892 24800	●	●		●		●	●		●			●
160			50				20			83,40	80 892 24900	●			●		●	●					●

Pregled splošnih čeljustnih nastavkov

Čeljust s prizmo

- ▲ z vodoravno in navpično prizmo
- ▲ Prizme so vzporedne ter brušene horizontalno in vertikalno
- ▲ Cena za kos

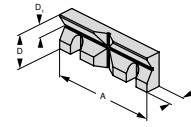

Za vpenjalni premer	A	A ₁	D	D ₁	D ₂	E	M	M ₁	M ₂	EUR	Y4	NCG	H5G / -S / -Z	X5G-Z / -S	ESG 4	ESG 5	HDG 2	ZSG 4	ZSG mini	DSG 4	Verso	HSG	
11 - 41	100		35	13			15,5			128,40	80 892 26100	●					●						●
14 - 48	125		40	16			17,5			142,90	80 892 26200	●	●		●		●				●		●
16 - 60	160		50	20			19,5			214,00	80 892 26300	●			●		●	●					●

Čeljust s prizmo

- ▲ z vodoravno in navpično prizmo
- ▲ Cena za kos

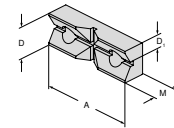

Za vpenjalni premer	A	A ₁	D	D ₁	D ₂	E	M	M ₁	M ₂	EUR	Y4	NCG	H5G / -S / -Z	X5G-Z / -S	ESG 4	ESG 5	HDG 2	ZSG 4	ZSG mini	DSG 4	Verso	HSG	
11 - 22	65		22	11			15			131,00	80 895 337	●						●					

Precizna čeljust z vlekem navzdol

- ▲ Čeljust z vlekem navzdol je zasnovana samo za uporabo na prečni čeljusti
- ▲ Cena za kos

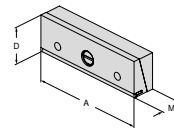

Za širino primeža	A	A ₁	D	D ₁	D ₂	E	M	M ₁	M ₂	EUR	Y4	NCG	H5G / -S / -Z	X5G-Z / -S	ESG 4	ESG 5	HDG 2	ZSG 4	ZSG mini	DSG 4	Verso	HSG	
100			35				25			259,00	80 892 370	●											●
125			40				25			268,00	80 892 371	●	●		●						●		●
160			50				27,5			409,00	80 892 372	●			●								●

Vmesna čeljust z vlekem navzdol

- ▲ za tipe NCG, NCG 2 in HDG 2
- ▲ z listnatimi vzmetmi za vlek navzdol na obeh straneh
- ▲ Cena za kos

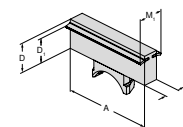

Za širino primeža	A	A ₁	D	D ₁	D ₂	E	M	M ₁	M ₂	EUR	Y4	NCG	H5G / -S / -Z	X5G-Z / -S	ESG 4	ESG 5	HDG 2	ZSG 4	ZSG mini	DSG 4	Verso	HSG	
100			35	28			28	45		289,00	80 892 258	●											
125			40	32,5			20	35		283,00	80 892 259	●					●						
160			50	42			20	35		337,00	80 892 260	●					●						

Pregled splošnih čeljustnih nastavkov

Predložna čeljust Multipin

▲ Cena za kos

NCG HDG
2



80 890 ...

EUR
Y4
315,00 30200

A mm	D mm
125	40

Čeljust z vlekem navzdol z vzmetno pločevino

▲ Za obdelavo končnih sestavnih delov
▲ Cena za kos

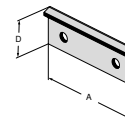

Za širino primeža	A	A ₁	D	D ₁	D ₂	E	M	M ₁	M ₂	EUR	Y4	NCG	H5G / -S / -Z	X5G-Z / -S	ESG 4	ESG 5	HDG 2	ZSG 4	ZSG mini	DSG 4	Verso	HSG	
80			24							66,90	80 901 309												
125			35							87,40	80 901 310				●				●		●		
160			45							99,30	80 901 311				●				●		●		

Čeljust z vlekem navzdol z vzmetno pločevino

▲ Za obdelavo končnih sestavnih delov
▲ Cena za kos

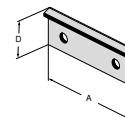

Za širino primeža	A	A ₁	D	D ₁	D ₂	E	M	M ₁	M ₂	EUR	Y4	NCG	H5G / -S / -Z	X5G-Z / -S	ESG 4	ESG 5	HDG 2	ZSG 4	ZSG mini	DSG 4	Verso	HSG	
65			23							57,30	80 898 923												
100			36							73,40	80 898 924	●											●
125			41							87,40	80 898 925	●											●
160			51							99,30	80 898 926	●											●

Čeljust z vlekem navzdol z listno vzmetjo

▲ Cena za kos

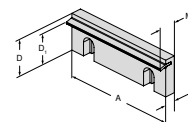

Za širino primeža	A	A ₁	D	D ₁	D ₂	E	M	M ₁	M ₂	EUR	Y4	NCG	H5G / -S / -Z	X5G-Z / -S	ESG 4	ESG 5	HDG 2	ZSG 4	ZSG mini	DSG 4	Verso	HSG	
100			35	28			10	18,5		59,50	80 892 22800	●											●
125			40	32,5			11,5	19		69,10	80 892 22900	●			●								●
160			50	42			13,5	21		89,60	80 892 23000	●			●								●

Pregled podlog za obdelovance

Podloga za obdelovane, z odmikom

- ▲ Kaljeno in brušeno
- ▲ Namestitev v osnovni plošči z vpenjalnimi vzmetmi
- ▲ Cena za 2 kosa

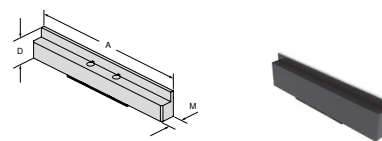

Za širino primeža	A	A ₁	D	D ₁	D ₂	E	M	M ₁	M ₂	EUR	Y4	NCG	H5G / -S / -Z	X5G-Z / -S	ESG 4	ESG 5	HDG 2	ZSG 4	ZSG mini	DSG 4	Verso	HSG		
100			16				10,5			135,00	80 890 401	●												
100			11				10,5			135,00	80 890 400	●												
100			23				10,5			135,00	80 890 409	●												
100			25,5				10,5			135,00	80 890 411	●												
100			29,5				10,5			135,00	80 890 421	●												
125			32,5				10,5			157,00	80 890 395	●												
125			11				10,5			157,00	80 890 390	●												
125			16				10,5			157,00	80 890 391	●												
125			21				10,5			157,00	80 890 392	●												
125			26				10,5			157,00	80 890 393	●												
125			29				10,5			157,00	80 890 394	●												
125			36				10,5			157,00	80 890 396	●												
125			25				10,5			157,00	80 890 422	●												
160			39				10,5			200,00	80 890 454	●												
160			26				10,5			190,00	80 890 452	●												
160			42,5				10,5			214,00	80 890 456	●												

Za širino primeža	A	A ₁	D	D ₁	D ₂	E	M	M ₁	M ₂	EUR	Y4	NCG	H5G / -S / -Z	X5G-Z / -S	ESG 4	ESG 5	HDG 2	ZSG 4	ZSG mini	DSG 4	Verso	HSG	
125							10,5			1.030,00	80 890 399	●											

 **80 890 399:** komplet s 7 podlogami za obdelovane, po 2 kosa v leseni škatli (samo **80 890 422**)

Podloga za obdelovane, z odmikom

- ▲ Kaljeno in brušeno
- ▲ Namestitev v osnovni plošči z vpenjalnimi vzmetmi
- ▲ Dostava v kompletu po 2 kosa
- ▲ Cena za komplet

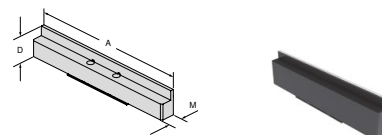

Za širino primeža	A	A ₁	D	D ₁	D ₂	E	M	M ₁	M ₂	EUR	Y4	NCG	H5G / -S / -Z	X5G-Z / -S	ESG 4	ESG 5	HDG 2	ZSG 4	ZSG mini	DSG 4	Verso	HSG			
125			11				10,5			153,00	80 901 703				●										
125			21				10,5			157,00	80 901 704				●										
125			25				10,5			153,00	80 901 705				●										
160			26				10,5			186,00	80 901 700				●										
125			32,5				10,5			153,00	80 901 706				●										
160			39				10,5			196,00	80 901 701				●										
160			42,5				10,5			210,00	80 901 702				●										

Podloga za obdelovane, z odmikom

- ▲ Kaljeno in brušeno
- ▲ Namestitev v osnovni plošči z vpenjalnimi vzmetmi
- ▲ Dostava v kompletu po 2 kosa
- ▲ Cena za komplet

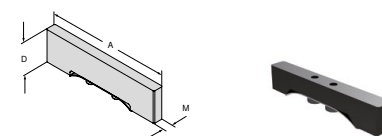

Za širino primeža	A	A ₁	D	D ₁	D ₂	E	M	M ₁	M ₂	EUR	Y4	NCG	H5G / -S / -Z	X5G-Z / -S	ESG 4	ESG 5	HDG 2	ZSG 4	ZSG mini	DSG 4	Verso	HSG				
80			15				10,5			127,00	80 901 707				●											
80			20				10,5			127,00	80 901 708				●											

Pregled podlog za obdelovance

Podloga za obdelovane, z odmikom

- ▲ Kaljeno in brušeno
- ▲ Namestitev v osnovni plošči z vpenjalnimi vzmetmi
- ▲ Dostava v kompletu po 2 kosa
- ▲ Cena za komplet

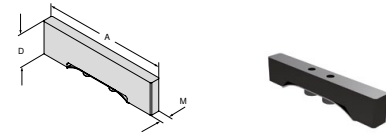

Za širino primeža	A	A ₁	D	D ₁	D ₂	E	M	M ₁	M ₂	EUR	Y4	NCG	H5G / -S / -Z	X5G-Z / -S	ESG 4	ESG 5	HDG 2	ZSG 4	ZSG mini	DSG 4	Verso	HSG		
125			15				10,5			157,00	80 906 715													
125			22				10,5			157,00	80 906 722													
125			25				10,5			157,00	80 906 725													
125			32,5				10,5			157,00	80 906 732													

Podloge za obdelovane, posneta

- ▲ Kaljeno in brušeno
- ▲ Namestitev v osnovni plošči z vpenjalnimi vzmetmi
- ▲ Cena za 2 kosa

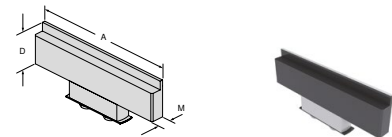

Za širino primeža	A	A ₁	D	D ₁	D ₂	E	M	M ₁	M ₂	EUR	Y4	NCG	H5G / -S / -Z	X5G-Z / -S	ESG 4	ESG 5	HDG 2	ZSG 4	ZSG mini	DSG 4	Verso	HSG			
100			16				10,5			131,00	80 892 401														
100			25,5				10,5			131,00	80 892 411														
100			29,5				10,5			131,00	80 892 421														
125			11				10,5			157,00	80 892 390														
125			16				10,5			157,00	80 892 391														
125			21				10,5			157,00	80 892 392														
125			26				10,5			157,00	80 892 393														
125			29				10,5			157,00	80 892 394														
125			32,5				10,5			157,00	80 892 395														
125			36				10,5			157,00	80 892 396														
160			26				10,5			190,00	80 892 403														
160			39				10,5			200,00	80 892 413														
160			42,5				10,5			214,00	80 892 423														

Za širino primeža	A	A ₁	D	D ₁	D ₂	E	M	M ₁	M ₂	EUR	Y4	NCG	H5G / -S / -Z	X5G-Z / -S	ESG 4	ESG 5	HDG 2	ZSG 4	ZSG mini	DSG 4	Verso	HSG		
125							10,5			1.030,00	80 892 399													

80 892 399: komplet s 7 podlogami za obdelovane, po 2 kosa v leseni škatli

Magnetne podloge za obdelovance, komplet



- ▲ S prosto nastavitvijo na spodnji strani
- ▲ Fleksibilno in racionalno vpenjanje
- ▲ Natančnost višine +/- 0,01 mm
- ▲ Z magnetnim oprijemom, preprosta in hitra montaža

Pregled podlog za obdelovance

Magnetne podloge za obdelovance, komplet

- ▲ Nerjavno vzmetno jeklo
- ▲ Stisnjeni magneti
- ▲ Dobava v kompletu: 5 parov po 2 kosa
- ▲ Cena za komplet



A	D	M	EUR	Y4	NCG	H5G /-S /-Z	X5G-Z /-S	ESG 4	ESG 5	HDG 2	ZSG 4	ZSG mini	DSG 4	Verso	HSG
80	5 / 10 / 15 / 20 / 22	2,5	297,00	80 878 79800	●		●	●			●		●		
125	8 / 12 / 15 / 20 / 22	2,5	334,00	80 878 79700	●		●	●			●		●		
125	8 / 12 / 20 / 25 / 27	2,5	334,00	80 878 79900	●		●	●			●		●		

Magnetne podloge za obdelovance, komplet

- ▲ Nerjavno vzmetno jeklo
- ▲ Stisnjeni magneti
- ▲ Dobava v kompletu: 5 parov po 2 kosa
- ▲ Cena za komplet



A	D	M	EUR	Y4	NCG	H5G /-S /-Z	X5G-Z /-S	ESG 4	ESG 5	HDG 2	ZSG 4	ZSG mini	DSG 4	Verso	HSG
100	12 / 20 / 25 / 30 / 32	2,5	325,00	80 892 79700	●		●				●	●			
125	12 / 25 / 30 / 35 / 37	2,5	342,00	80 892 79800	●		●				●	●	●		
160	15 / 30 / 40 / 45 / 47	2,5	360,00	80 892 79900	●		●	●			●	●			

Magnetne podloge za obdelovance, komplet

- ▲ nerjavno vzmetno jeklo
- ▲ stisnjeni magneti
- ▲ Dobava v kompletu: 5 parov po 2 kosa
- ▲ Cena za komplet



A	D	M	EUR	Y4	NCG	H5G /-S /-Z	X5G-Z /-S	ESG 4	ESG 5	HDG 2	ZSG 4	ZSG mini	DSG 4	Verso	HSG
125	9 / 22 / 27 / 32 / 34	2,5	334,00	80 901 79900	●		●				●		●		

Pregled podlog za obdelovance

Magnetne podloge za obdelovance

▲ Cena za par

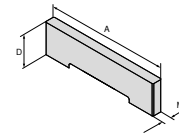

A	D	M	EUR	Y4	NCG	H6G / -S / -Z	X5G-Z / -S	ESG 4	ESG 5	HDG 2	ZSG 4	ZSG mini	DSG 4	Verfo	HSG
80	5	2,5	68,00	80 892 79600											
80	10	2,5	68,00	80 892 79500											
80	15	2,5	68,00	80 892 79400											
80	20	2,5	68,00	80 892 79300											
80	22	2,5	68,00	80 892 79200											
100	12	2,5	71,30	80 892 79100											
100	20	2,5	71,30	80 892 79000											
100	25	2,5	71,30	80 892 78900											
100	27	2,5	71,30	80 892 78800											
100	29	2,5	71,30	80 892 78700											
100	30	2,5	71,30	80 892 78600											
100	31	2,5	71,30	80 892 78500											
100	32	2,5	71,30	80 892 78400											
125	8	2,5	74,50	80 892 78300											
125	9	2,5	74,50	80 892 78200											
125	10	2,5	74,50	80 892 78100											
125	12	2,5	74,50	80 892 78000											
125	15	2,5	74,50	80 892 77900											
125	20	2,5	74,50	80 892 77800											
125	22	2,5	74,50	80 892 77700											
125	23	2,5	74,50	80 892 77600											
125	25	2,5	74,50	80 892 77500											
125	27	2,5	74,50	80 892 77400											
125	30	2,5	74,50	80 892 77300											
125	31	2,5	74,50	80 892 77200											
125	32	2,5	74,50	80 892 77100											
125	33	2,5	74,50	80 892 77000											
125	34	2,5	74,50	80 892 76900											
125	35	2,5	74,50	80 892 76800											
125	36	2,5	74,50	80 892 76700											
125	37	2,5	74,50	80 892 76600											
160	15	2,5	81,00	80 892 76500											
160	22	2,5	81,00	80 892 76400											
160	30	2,5	81,00	80 892 76300											
160	37	2,5	81,00	80 892 76200											
160	40	2,5	81,00	80 892 76100											
160	41	2,5	81,00	80 892 76000											
160	42	2,5	81,00	80 892 75900											
160	43	2,5	81,00	80 892 75800											
160	44	2,5	81,00	80 892 75700											
160	45	2,5	82,00	80 892 75600											
160	46	2,5	81,00	80 892 75500											
160	47	2,5	81,00	80 892 75400											

Prislon za obdelovanec, magneten

Obseg dobave:

Vključno s prislonsko palico 50 mm/100 mm



Za širino mm	Velikost	80 892 ...
		EUR Y4
80/100/125/160	60x15	113,00 23800
80/100/125/160	115x15	164,00 23900

Podaljšek prislona za obdelovanec, magnetni

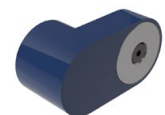

Za širino mm	Velikost	80 892 ...
80/100/125/160	68x30 mm	EUR Y4 87,40 25400

Pregled splošnega pribora

Komplet za usmeritev
in centriranje za T-utor

▲ Cena za kos

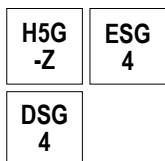

80 897 ...

I mm	Za širino utorov mm	EUR Y4	
100	14	57,10	114
100	16	57,10	116
100	18	57,10	118

Komplet za usmeritev
in centriranje

▲ Cena za kos

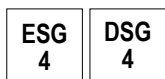

80 906 ...

I mm	Za širino utorov mm	EUR Y4	
80	12	59,50	812
80	14	59,50	814
80	16	59,50	816
80	18	59,50	818

Komplet vpenjalnih vijakov
za T-utor za MNG

▲ Cena za 2 kosa



80 899 ...

Za širino mm	G	EUR Y4	
12	M10	15,20	312
14	M12	15,20	314
16	M12	20,50	316
18	M12	26,00	318

Prislon za obdelovanec

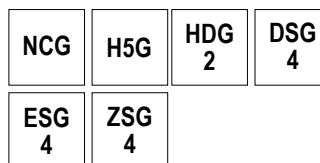

80 892 ...

EUR
Y4
81,70 400

Prislon za obdelovanec



80 895 ...

EUR
Y4
44,80 010

Prislon za obdelovanec

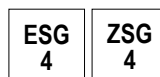

80 884 ...

EUR
Y4
43,70 400

Pregled splošnega pribora

Nadomestna listna vzmet

▲ Cena za kos

▲ za čeljusti z vlekom navzdol in vmesne čeljusti

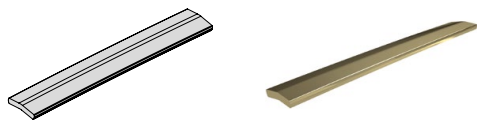

Za širino mm	80 892 ... EUR Y4	
100	23,90	430
125	24,90	431
160	27,10	432

Vpenjalne spono

▲ Cena za 2 kosa

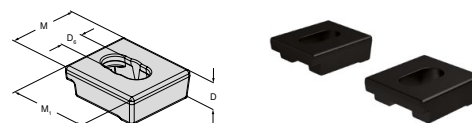

D mm	D ₆ mm	M mm	M ₁ mm	80 890 ... EUR Y4	
20	16	50	57	38,10	315

Pregled vpenjalnih ročic

Vpenjalna ročica z zglobom

▲ brez natičnega nastavka



Zatezni moment v Nm	Štirirobi	DRVS	EUR	Y4	NCG	H5G / -S / -Z	X5G-Z / -S	ESG 4	ESG 5	HDG 2	ZSG 4	ZSG mini	DSG 4	Verso	HSG	MNG	MNG mini
	1/2"		76,10	80 891 600				●			●						

Momentni ključ

▲ brez natičnega nastavka



Zatezni moment v Nm	Štirirobi	DRVS	EUR	Y4	NCG	H5G / -S / -Z	X5G-Z / -S	ESG 4	ESG 5	HDG 2	ZSG 4	ZSG mini	DSG 4	Verso	HSG	MNG	MNG mini
10 - 100	1/2"		280,00	80 884 502				●			●	●	●				
20 - 200	1/2"		280,00	80 884 504				●			●	●	●				

Momentni ključ

▲ brez natičnega nastavka



Zatezni moment v Nm	Štirirobi	DRVS	EUR	Y4	NCG	H5G / -S / -Z	X5G-Z / -S	ESG 4	ESG 5	HDG 2	ZSG 4	ZSG mini	DSG 4	Verso	HSG	MNG	MNG mini
5 - 50	3/8"		280,00	80 884 402								●		●		●	

Komplet za vpenjanje

▲ Momentni ključ vklj. z nastavkom,
izvijajč z zevom ključa 10 in 1/2" podaljsek

Zatezni moment v Nm	Štirirobi	DRVS	EUR	Y4	NCG	H5G / -S / -Z	X5G-Z / -S	ESG 4	ESG 5	HDG 2	ZSG 4	ZSG mini	DSG 4	Verso	HSG	MNG	MNG mini
8 - 50	3/8"	10	329,00	80 899 410												●	

Pregled vpenjalnih ročic

Natični nastavek

▲ Primerno za 1/2- ali 3/8-palčni štiriobnik



Zatezni moment v Nm	Štiriobni	DRVS	EUR	Y4	NCG	H5G / -S / -Z	X5G-Z / -S	ESG 4	ESG 5	HDC 2	ZSG 4	ZSG mini	DSG 4	Veriso	HSG	MNG	MNG mini
	3/8"	5	18,20	80 877 105													
	3/8"	6	18,20	80 877 10600													
	3/8"	8	18,20	80 877 108										•		•	•
	1/2"	8	18,20	80 877 208													
	1/2"	10	18,20	80 877 210													
	1/2"	14	18,20	80 877 214			•										

Natični nastavek

▲ Primerno za 1/2- ali 3/8-palčni štiriobnik



Zatezni moment v Nm	Štiriobni	DRVS	EUR	Y4	NCG	H5G / -S / -Z	X5G-Z / -S	ESG 4	ESG 5	HDC 2	ZSG 4	ZSG mini	DSG 4	Veriso	HSG	MNG	MNG mini
	3/8"	7	18,20	80 875 107													
	3/8"	11	18,20	80 875 11100								•					
	3/8"	12	18,20	80 875 112				•			•		•				
	1/2"	12	18,20	80 875 212				•			•		•				
	1/2"	14	18,20	80 875 214				•			•		•				

Pregled vijakov

Vpenjalni vijak za čeljustne nastavke

▲ DIN EN ISO 4762 (1998-02)



Za širino primeža	G	J ₁₇	EUR	Y4	NCG	H5G / -S / -Z	X5G-Z / -S	ESG 4	ESG 5	HDG 2	ZSG 4	ZSG mini	DSG 4	Verzo	HSG	MNG	MNG mini
	M8x12		1,20	80 892 296	●	●				●	●						
	M6x8		1,20	80 895 013								●		●			

Vpenjalni vijak z nizko glavo za čeljustne nastavke

▲ podobno DIN7984 (1985-05)



Za širino primeža	G	J ₁₇	EUR	Y4	NCG	H5G / -S / -Z	X5G-Z / -S	ESG 4	ESG 5	HDG 2	ZSG 4	ZSG mini	DSG 4	Verzo	HSG	MNG	MNG mini
	M8x10		1,20	80 889 950	●	●				●	●						

Vpenjalni vijak za sistemske čeljusti

▲ Cena za kos



Za širino primeža	G	J ₁₇	EUR	Y4	NCG	H5G / -S / -Z	X5G-Z / -S	ESG 4	ESG 5	HDG 2	ZSG 4	ZSG mini	DSG 4	Verzo	HSG	MNG	MNG mini
	M12x20		1,20	80 890 630	●	●											
	M12x40		2,30	80 890 632	●	●											

Imbus vijak

▲ DIN 912



Za širino primeža	G	J ₁₇	EUR	Y4	NCG	H5G / -S / -Z	X5G-Z / -S	ESG 4	ESG 5	HDG 2	ZSG 4	ZSG mini	DSG 4	Verzo	HSG	MNG	MNG mini
	M12x45		2,30	80 899 124												●	

Vijak za namestitvev

▲ Cena za 2 kosa



Za širino primeža	G	J ₁₇	EUR	Y4	NCG	H5G / -S / -Z	X5G-Z / -S	ESG 4	ESG 5	HDG 2	ZSG 4	ZSG mini	DSG 4	Verzo	HSG	MNG	MNG mini
100	M12x38	12	45,70	80 890 313	●			●									
125 / 160	M16x55	16	60,80	80 890 314	●												

Pregled vijakov

Vijak za namestitvev

▲ Cena za 2 kosa

Za širino primeža	G	J ₁₇	EUR	Y4	NCG	H5G / -S / -Z	X5G-Z / -S	ESG 4	ESG 5	HDG 2	ZSG 4	ZSG mini	DSG 4	Verso	HSG	MING	MING mini	
125	M12x45	12	26,20	80 895 019	●	●	●	●	●	●	●	●	●	●	●	●	●	●



Vpenjalni vijak s T-utorno matico

▲ za pritrditev vpenjalne spone

▲ Cena za 2 kosa

za širino utora	G	J ₁₇	EUR	Y4	NCG	H5G / -S / -Z	X5G-Z / -S	ESG 4	ESG 5	HDG 2	ZSG 4	ZSG mini	DSG 4	Verso	HSG	MING	MING mini	
12	M10		24,30	80 890 308	●	●	●	●	●	●	●	●	●	●	●	●	●	●
14	M12		24,30	80 890 309	●	●	●	●	●	●	●	●	●	●	●	●	●	●
16	M14		25,20	80 890 310	●	●	●	●	●	●	●	●	●	●	●	●	●	●
18	M16		26,30	80 890 311	●	●	●	●	●	●	●	●	●	●	●	●	●	●



Vpenjalni vijak za okroglo vpenjalno orodje, T-utor

▲ Vklj. z utorno matico in vmesno podložko

▲ Cena za 2 kosa

za širino utora	G	J ₁₇	EUR	Y4	NCG	H5G / -S / -Z	X5G-Z / -S	ESG 4	ESG 5	HDG 2	ZSG 4	ZSG mini	DSG 4	Verso	HSG	MING	MING mini
12	M10		15,80	80 899 112										●	●	●	●
14	M12		15,80	80 899 114										●	●	●	●
16	M12		17,30	80 899 116										●	●	●	●
18	M12		18,50	80 899 118										●	●	●	●



Prilagodna utorna matica, vklj. z vijakom

▲ Cena za 2 kosa

za širino utora	G	J ₁₇	EUR	Y4	NCG	H5G / -S / -Z	X5G-Z / -S	ESG 4	ESG 5	HDG 2	ZSG 4	ZSG mini	DSG 4	Verso	HSG	MING	MING mini	
12	M6		91,20	80 898 412	●	●	●	●	●	●	●	●	●	●	●	●	●	●
14	M6		91,20	80 898 414	●	●	●	●	●	●	●	●	●	●	●	●	●	●
16	M6		91,20	80 898 416	●	●	●	●	●	●	●	●	●	●	●	●	●	●
18	M6		91,20	80 898 418	●	●	●	●	●	●	●	●	●	●	●	●	●	●

