



 ZSG 1 www.zsg.com

 CERATIZIT GROUP MNG mini

 ZSG mini

Nové produkty v oblasti zverákov a upínacích systémov

NEW Mechanický upínací systém s nulovým bodom – MNG mini



149–151

MNG mini

Optimalizovaná hmotnosť konzol, pyramíd a upínacích veží s integrovaným upínacím systémom s nulovým bodom pre malé zveráky.

NEW CentriClamp – ZSG mini



92–100

ZSG mini

Zverák ZSG mini je ideálnou voľbou pre upínanie malých obrobkov.

NEW PolyClamp – Verso



111–124

Verso

Nový flexibilný viacnásobný zverák s rýchlovýmennými čelustami pre upínanie niekoľko malých i veľkých obrobkov.

1 HSS vrtáky

2 TK vrtáky

3 Vrtáky s vymeniteľnými doštičkami

4 Výstružníky a záhlbníky

5 Nástroje na vyvrtávanie

6 Závitníky

7 Frézovanie závitov a cirkulárne frézovanie

8 Sústruženie závitov

9 Sústružnicke nože s vymeniteľnými doštičkami

10 Multifunkčné nástroje – EcoCut a FreeTurn

11 Nástroje na zapichovanie a upichovanie

12 UltraMini obrábanie + MiniCut

13 HSS frézy

14 TK frézy

15 Frézy s vymeniteľnými doštičkami

16 Nástrojové držiaky a príslušenstvo

17 Upínanie obrobkov

18 Príklady materiálov a register obj. čísiel

Vŕtanie

Závitovanie

Sústruženie

Frézovanie

Technológia upínania

Obsah

PolyClamp – Verso	4
Prehľad upínacích systémov	5
Toolfinder – Zveráky	6–9
Produktová paleta	10–183
Prehľad výmenných čeľustí všeobecne	164–173
Prehľad podložiek pod obrobok	174–177
Prehľad všeobecného príslušenstva	178+179
Prehľad upínacích pák	180+181
Prehľad skrutiek	182+183

WNT \ Performance

Kvalitné prémiové nástroje pre maximálny výkon.

Kvalitné prémiové nástroje z produktového radu **WNT Performance** sa koncipovali pre špeciálne prípady použitia a vyznačujú sa zvlášť vysokým výkonom. Ak v rámci vlastnej výroby kladiete vysoké nároky na procesný výkon a chcete dosiahnuť optimálnych výsledkov, potom Vám odporúčame prémiové nástroje z tohto produktového radu.

PolyClamp – Verso

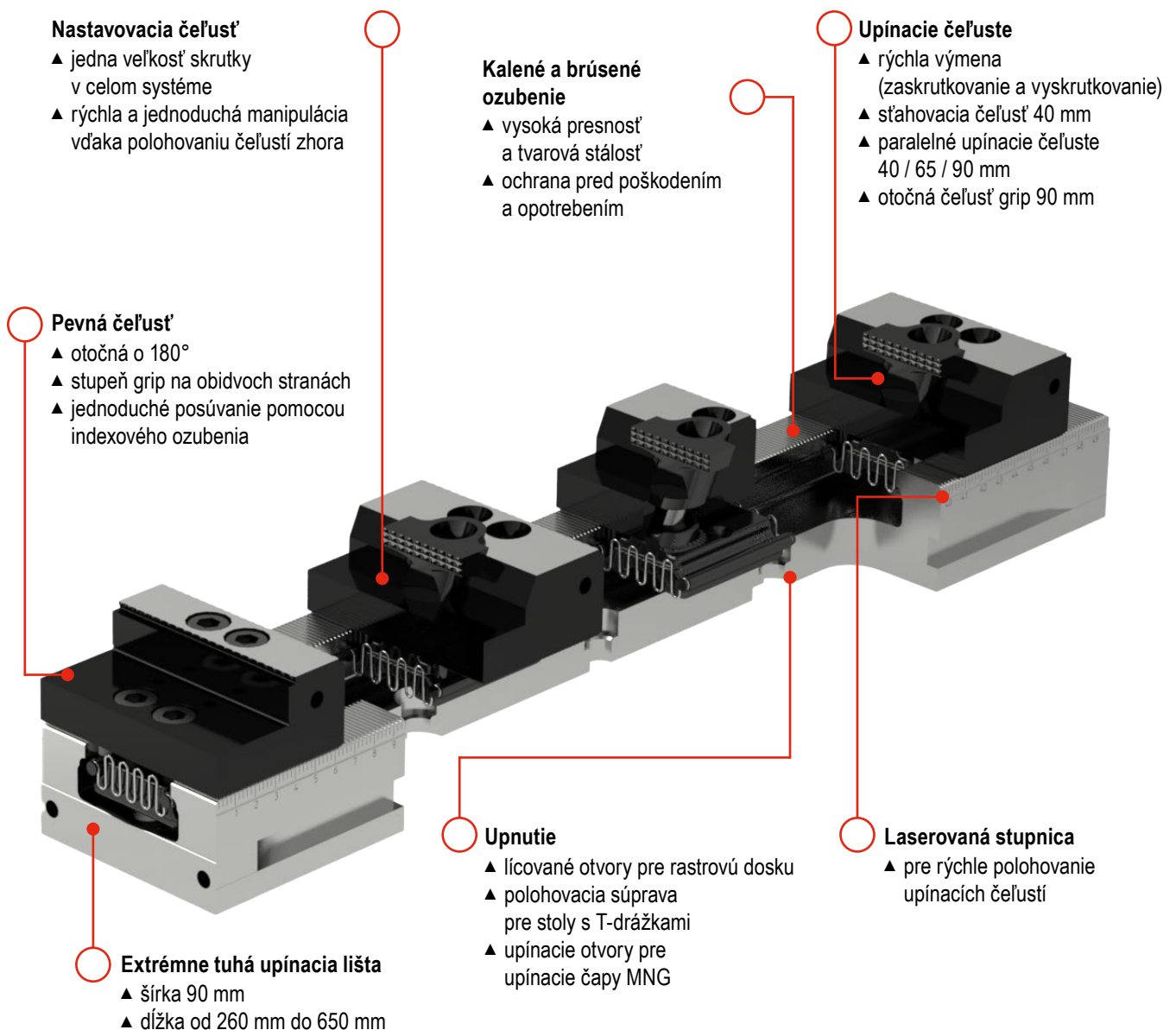

Prehľad upínacích systémov

SoloClamp – Jednoduché zveráky

- ▲ systémy NCG, HDG 2 a H5G s posilňovačom
- ▲ pevná čelusť ako referencia
- ▲ vysoká presnosť opakovania
- ▲ veľmi dobrá uhlová presnosť



» Vysoká presnosť a zväčšenie upínacej sily

CentriClamp – Osové zveráky

- ▲ symetrické upínanie
- ▲ veľmi dobrý prístup pre 5osové obrábanie
- ▲ nulový bod obrobku je vždy v strede (v ose)
- ▲ vysoká presnosť opakovania



» Vysoká procesná spoľahlivosť vďaka zapuzdreným systémom

PolyClamp – Viacnásobné zveráky

- ▲ skrátenie prípravných časov
- ▲ možnosť univerzálneho použitia
- ▲ optimálne využitie strojného stolu
- ▲ vysoká presnosť opakovania



» Predĺženie pracovného času stroja

Stacionárne trojčelustové skľučovadlo – SBF 3

- ▲ vhodný pre 3osové i 5osové obrábanie guľatých obrobkov
- ▲ kompatibilné s upínacími systémami s nulovým bodom PNG a MNG
- ▲ pohon čelustí pomocou ozubeného segmentu
- ▲ kalené a tuhé základné teleso
- ▲ optimalizovaný systém mazania



» Perfektné riešenie pre upínanie guľatých obrobkov

Varianty upínania

- ▲ upínacie systémy s nulovým bodom
- ▲ rastrové dosky pre upínací systém s nulovým bodom
- ▲ MNG – mechanický upínací systém s nulovým bodom
- ▲ PNG – pneumatický upínací systém s nulovým bodom



» Skrátenie prípravných časov

Upínacie veže

- ▲ dvojstranná upínacia veža
- ▲ trojuholníková upínacia veža
- ▲ štvorcová upínacia veža
- ▲ osemboká upínacia veža



» Jednoduchá automatizácia





Rôzne upínacie veže nájdete v našom online shope na cuttingtools.ceratzit.com



Toolfinder – zveráky

Typ	Popis	3osový	4osový	5osový	
SoloClamp – Jednoduché zveráky	NCG 	<ul style="list-style-type: none"> ▲ rýchle upínanie – 160° ▲ rýchla montáž aj demontáž jednotky vretena ▲ upínanie ťahom 	✓	✓	
	NCG 5A 	<ul style="list-style-type: none"> ▲ rýchle upínanie – 160° ▲ pre 5osové obrábanie ▲ upínanie ťahom 	✓		✓
	H5G 	<ul style="list-style-type: none"> ▲ rýchle upínanie – 160 ▲ 5osový strojný zverák ▲ 100 % zapuzdrenie 	✓		✓
	H5G -Z 	<ul style="list-style-type: none"> ▲ rýchle upínanie – 160° ▲ 5osový strojný zverák ▲ 100% zapuzdrenie ▲ s mobilnou pevnou čelustou 	✓		✓
	X5G -Z 	<ul style="list-style-type: none"> ▲ 100 % zapuzdrenie ▲ optimálna prístupnosť ▲ je možné vykonávať päťstranné a šesťstranné obrábanie ▲ rýchla výmena čelustí bez náradia 	✓		✓
	ESG 4 	<ul style="list-style-type: none"> ▲ 100 % zapuzdrenie ▲ presné základné teleso ▲ vysoká upínacia sila ▲ veľký upínací rozsah 	✓	✓	✓
	ESG 5 	<ul style="list-style-type: none"> ▲ nové prevedenie zapuzdreného osového zveráku ZSG 4 ako jednoduchý zverák ▲ identické konštrukčné rozmery a ovládanie ako u zveráka ZSG 4 	✓	✓	✓
	HDG 2 	<ul style="list-style-type: none"> ▲ mechanický prenos sily ▲ upínacej sily sa dosiahne iba jedným otočením kľukou ▲ plynulé nastavenie upínacej sily 	✓		
CentriClamp – Osové zveráky	ZSG 4 	<ul style="list-style-type: none"> ▲ vreteno s guľôčkovými ložiskami, nulová vôľa ▲ vysoká presnosť, upínacia sila a procesná spoľahlivosť ▲ presnosť opakovania ±0,01 mm 	✓	✓	✓
	ZSG mini 	<ul style="list-style-type: none"> ▲ rýchla výmena čelustí bez použitia náradia ▲ kompaktnosť a precíznosť ▲ optimálny prístup zo všetkých strán ▲ nehrdzavejúce a kalené základné teleso 	✓	✓	✓

	Šírka čelusti v mm	Dĺžka základného telesa v mm	Max. upínací rozsah v mm	Kubické obrobky	Neforemné obrobky	Gulaté obrobky	Max. upínacia síla v kN	Strana
	100 125 160	305 390 530	245 343 506	✓	✓	✓	30 40 40	10-21
	100 125	305 390	199 269	✓		✓	18 24	13-21
	125	300	249	✓	✓	✓	40	22-36
	125	330 430 500 630	396 466 578	✓	✓	✓	40	26-36
	125	330 430 500 630 800	80-210 80-310 80-380 80-510 80-688	✓	✓	✓	40	37
	80 125 160	214 362 480	192 308 434	✓	✓	✓	25 40 50	49-58
	80 125 160	130+190 160+235+300 280+480	63-171 84-281 125-448	✓	✓	✓	35 35 50	59-66
	100 125 160	342 400 544	278 338 470	✓		✓	30 40 60	68-71
	80 125 160	130+190 160+235+300 280+480	121-185 163-303 134-462	✓	✓	✓	25 40 50	72-90
	45 70	80 100	7-77	✓	✓	✓	16	92-100

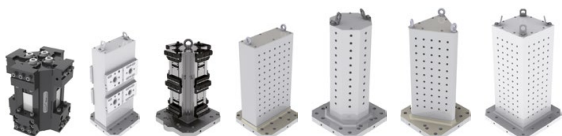

Toolfinder – zveráky

Typ	Popis	3osový	4osový	5osový
PolyClamp – Viacnásobné zveráky	DSG 4  <ul style="list-style-type: none"> ▲ rýchla demontáž i montáž ▲ flexibilný upínací systém ▲ možnosť prestavby na jednoduchý zverák 	✓	✓	✓
	Verso  <ul style="list-style-type: none"> ▲ variabilný upínací systém ▲ upínanie niekoľkých malých i veľkých obrobkov ▲ inovatívny viacnásobný upínací systém 	✓	✓	✓
Stacionárne trojčelustové sklúčovadlo	SBF 3  <ul style="list-style-type: none"> ▲ vhodné pre 3 a 5osové obrábanie rotačných obrobkov ▲ kompatibilné s upínacími systémami s nulovým bodom PNG a MNG 	✓		✓
	 <ul style="list-style-type: none"> ▲ vhodné pre 3 a 5osové obrábanie rotačných obrobkov ▲ kompatibilné s upínacími systémami s nulovým bodom PNG a MNG 	✓		✓

Typ	Popis	
Upínacie systémy s nulovým bodom	Mechanický	MNG  <ul style="list-style-type: none"> ▲ univerzálna doska pre každý strojný stôl
		MNG mini  <ul style="list-style-type: none"> ▲ na upínanie menších obrobkov
	Pneumatický	PNG  <ul style="list-style-type: none"> ▲ procesná spoľahlivosť vďaka samosvornému prevedeniu
Upínacie veže	 <ul style="list-style-type: none"> ▲ predĺženie pracovného času stroja 	

Strojový, ručný zverák

Manuálne ovládaný zverák	HSG  <ul style="list-style-type: none"> ▲ rýchle nastavenie čelustí, kompaktné a presné
--------------------------	--

Šírka čelusti v mm	Dĺžka základného telesa v mm	Max. upínací rozsah v mm	Kubické obrobky	Neforemné obrobky	Gulaté obrobky	Max. upínacia sila v kN	Strana
80	300	102	✓	✓	✓	25	101-110
125	320+390+460 530+600+670+740	114+149+184 219+254+289+324				40	
40 65 90	260 -650	524	✓	✓	✓	30	111-124
	Ø 200	Čeluste SB-H 6-180			✓	100	125-130
	Ø 315	Čeluste SB-H 12-420			✓	180	
	Mechanický	Pneumatický			Poznámka		Strana
	✓						134-148
	✓						149-151
		✓					152-163
	✓				Tieto artikly nájdete v našom online e-shope vid' cuttingtools.ceratizit.com	 	
	✓						131-133

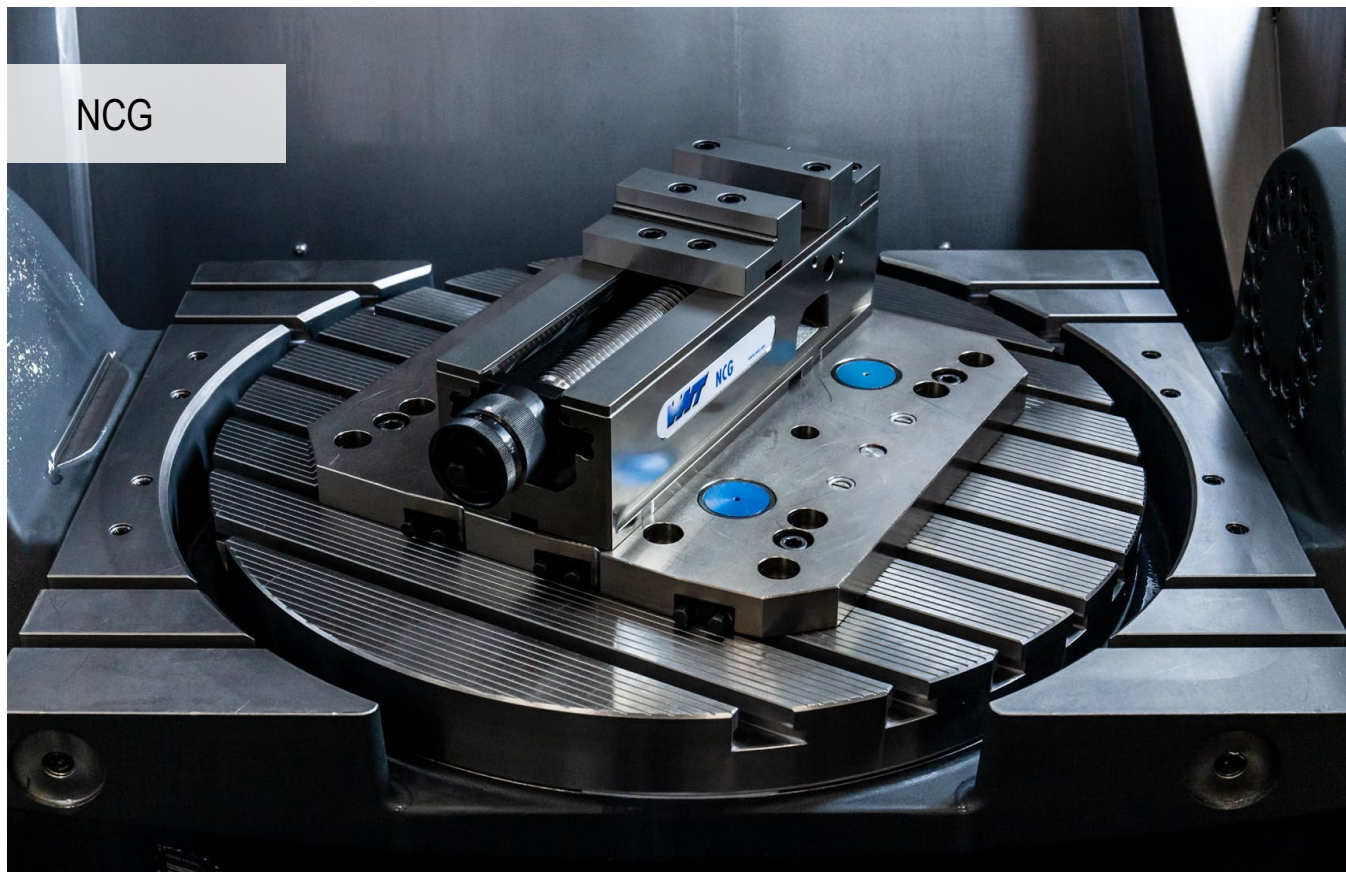

System pre upínanie

Modulárny strojný zverák ako systém, ktorý upína ťahom. Jedinečné, patentované rýchlopúpanie pomocou páky s mechanickým posilňovačom a s vynaložením minimálneho prípravného času.

Výhody pre Vás:

- ▲ rýchle nastavenie pomocou ručnej kľuky
- ▲ rýchle polohovanie pomocou MNG na strojnom stole bez rastrovej palety
- ▲ možnosť plynulého nastavenia upínacej sily od 4 - 40 kN
- ▲ rýchle upínanie – 160°
- ▲ jednoduchá a rýchla výmena čelustí pomocou 4 skrutiek
- ▲ jednoduché čistenie vďaka rýchlej demontáži kompletnej jednotky vretena
- ▲ široká paleta čelustí – a príslušenstva



Upnutie / Vyrovnávanie:



Upnutie pomocou dvoch lícovaných skrutiek
Ø 12₇ / M12 (NCG 100) Artikel č. 80 890 313 alebo
Ø 16₉₅ / M16 (NCG 125 / 160) Artikel č. 80 890 314.



Vyrovnávanie do T drážok stola pomocou
kameňov lícovaných do drážok š. 20^{H7} v
základnom telese. Upnutie pomocou úpiniek.



Vyrovnávanie a upnutie pomocou systému s nulovým
bodom MNG (2-3 upínacie čapy).

SoloClamp – NCG

- ▲ rýchlopínací NCG zverák s kombinovanou otočnou čelustou Plus
- ▲ vďaka dodatočnému závitú je možné používať výmenné čeluste výšky 18 mm a 40 mm
- ▲ rýchle upnutie obrobku upínacou pákou v rozsahu do 160°
- ▲ rýchla montáž a demontáž jednotky vretena
- ▲ S = upínací krok

Rozsah dodávky:

Rýchlopínací NC zverák, vr. 4 upínacích piat, 2x kombinovaná otočná čelusť Plus, upínacia páka

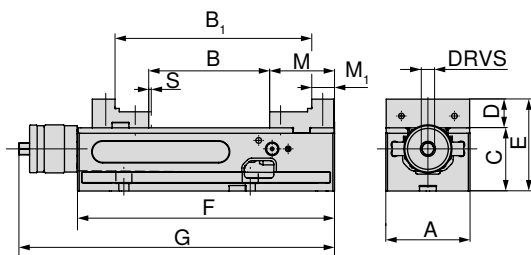
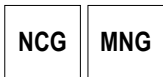

A	B	B ₁	C _{-0.02}	D	E	F	G	M	M ₁	S	DRVS	MXC	WT
mm	mm	mm	mm	mm	mm	mm	mm	mm	mm	mm	mm	kN	kg
125	0 - 212	96 - 307	100	39	139	390	457	89	39	3	14	4 - 40	34

80 890 ...

EUR
Y4

3.110,00 12500

SoloClamp – NCG

- ▲ rýchlopínací zverák NCG s kombinovanými otočnými čelustami
- ▲ rýchle upnutie obrobku upínacou pákou v rozsahu do 160°
- ▲ rýchla montáž a demontáž jednotky vretena
- ▲ S = upínací krok

Rozsah dodávky:

Rýchlopínací NC zverák, vr. 4 upínacích piat, 2x kombinovaná otočná čelusť (jedna strana stupňovitá, jedna strana hladká), upínacia páka

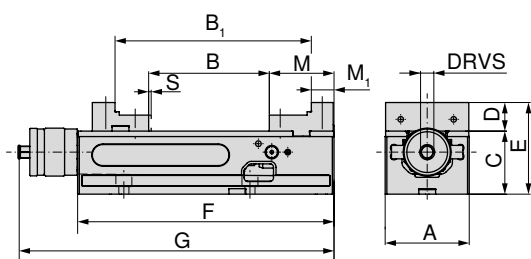
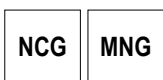

A	B	B ₁	C _{-0.02}	D	E	F	G	M	M ₁	S	DRVS	MXC	WT
mm	mm	mm	mm	mm	mm	mm	mm	mm	mm	mm	mm	kN	kg
100	0 - 155	91 - 245	75	34	109	305	374	77	27	2,5	14	4 - 30	19
125	0 - 212	96 - 307	100	39	139	390	457	89	39	3	14	4 - 40	34
160	0 - 314	113 - 426	115	49	164	530	600	108	52	3	14	4 - 40	68

80 890 ...

EUR
Y4

2.660,00 602

3.080,00 627

4.040,00 662

Prehľad zverákov

Rozmery spodnej strany	14	Systémové príslušenstvo	16-21
Upínací systém s nulovým bodom MNG/PNG	134-163	Obecné príslušenstvo	164-183

SoloClamp – NCG

- ▲ rýchlopínací zverák NCG so štandardnými otočnými čelistami
- ▲ rýchle upnutie obrobku upínacou pákou v rozsahu do 160°
- ▲ rýchla montáž a demontáž jednotky vretena
- ▲ S = upínací krok

Rozsah dodávky:

Rýchlopínací NC zverák, vr. 4 upínacích piat, 2x štandardná otočná čeľusť (jedna strana hladká, jedna strana drážkovaná), upínacia páka

NCG

MNG

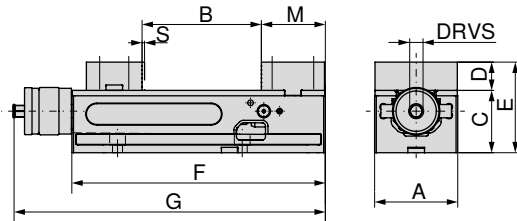

A	B	C _{-0.02}	D	E	F	G	M	S	DRVS	MXC	WT	80 890 ...	
mm	mm	mm	mm	mm	mm	mm	mm	mm	mm	kN	kg	EUR	
100	0 - 155	75	34	109	305	374	77	2,5	14	4 - 30	19,5	2.580,00	600
125	0 - 212	100	39	139	390	457	89	3	14	4 - 40	35,0	3.010,00	625
160	0 - 314	115	49	164	530	600	108	3	14	4 - 40	70,0	3.960,00	660

SoloClamp – NCG

- ▲ rýchlopínací zverák NCG s adaptérovou a výkyvnou čelistou
- ▲ rýchle upnutie obrobku upínacou pákou v rozsahu do 160°
- ▲ rýchla montáž a demontáž jednotky vretena
- ▲ S = upínací krok
- ▲ jednoduché upínanie polotovarov
- ▲ ľubovoľné nastavenie polohy 6násobných otočných čelustí, ktoré nájdete v príslušenstve

Rozsah dodávky:

Rýchlopínací NC zverák (základné teleso - typ NCG) s 1 adaptérovou čelistou (pevná) a 1 výkyvnou čelistou, upínacou pákou, 4 upínacími pätkami, bez 6násobných otočných čelustí

NCG

MNG

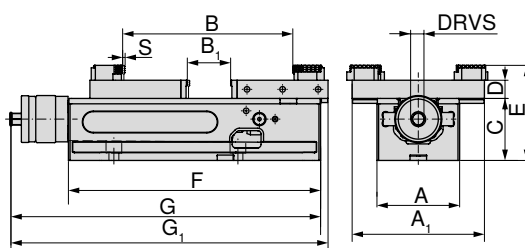

A	A ₁	B	B ₁	C _{-0.02}	D	E	F	G	G ₁	S	DRVS	MXC	WT	80 890 ...	
mm	mm	mm	mm	mm	mm	mm	mm	mm	mm	mm	mm	kN	kg	EUR	
100	160	10 - 230	0 - 77	75	22	115	305	374	383	2,5	14	4 - 30	19	2.770,00	636
125	192	16 - 343	0 - 152	100	22	140	390	457	478	3	14	4 - 40	34	3.220,00	637
160	256	15 - 506	0 - 237	115	22	155	530	600	631	3	14	4 - 40	68	4.250,00	638

Prehľad zverákov

Rozmery spodnej strany	14	Systémové príslušenstvo	16-21
Upínací systém s nulovým bodom MNG/PNG	134-163	Obecné príslušenstvo	164-183

SoloClamp – NCG 5A

- ▲ rýchlopínací zverák NCG 5A s vysokými upínacími čelustami
- ▲ rýchle upnutie obrobku upínacou pákou v rozsahu do 160°
- ▲ rýchla montáž a demontáž jednotky vretena
- ▲ S = upínací krok
- ▲ optimálny prístup je ideálnym predpokladom pre 5osové obrábanie
- ▲ za účelom rozšírenia upínacieho rozsahu je možné čeluste otáčať
- ▲ základné teleso 100 mm má 2 drážky pre presadenie pevnej čeluste
- ▲ základné teleso 125 mm má 3 drážky pre presadenie pevnej čeluste

Rozsah dodávky:

Rýchlopínací zverák NC, vr. 2 vysokých upínacích čelustí,
2 stupňovitých čelustí grip 5 mm, 1 upínacej páky, 4 upínacích pätičiek

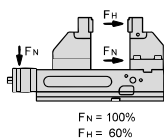
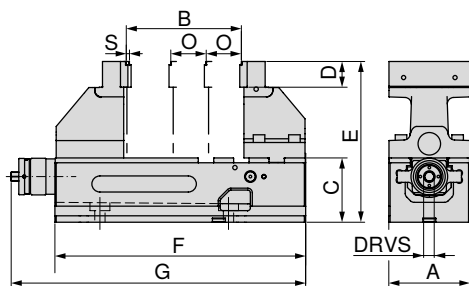
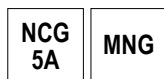

A	B	C	D	E	F	G	O	S	DRVS	MXC	WT
mm	mm	mm	mm	mm	mm	mm	mm	mm	mm	kN	kg
100	6 - 127	75	35	200	305	374	50	2,5	14	4 - 18 (30)	21,5
125	6 - 179	100	40	250	390	457	55	3	14	4 - 24 (40)	42,0

80 890 ...

EUR
Y43.210,00 605
3.710,00 635

Prehľad zverákov

Rozmery spodnej strany	14	Rozmerové tabuľky pre rôzne čeluste	15
Systémové príslušenstvo	16–21	Upínací systém s nulovým bodom MNG/PNG	134–163
Obečné príslušenstvo	164–183		

Rozmery spodnej strany NCG

Šírka základného telesa 100 mm

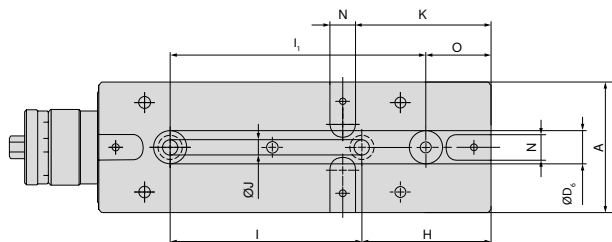

A	H	$I_{\pm 0,015}$	J_{F7}	K	N_{H7}	O	$I_1_{\pm 0,015}$	D_6_{H7}
mm	mm	mm	mm	mm	mm	mm	mm	mm
100	100	150	12	105	20	50	200	25

Šírka základného telesa 125 mm

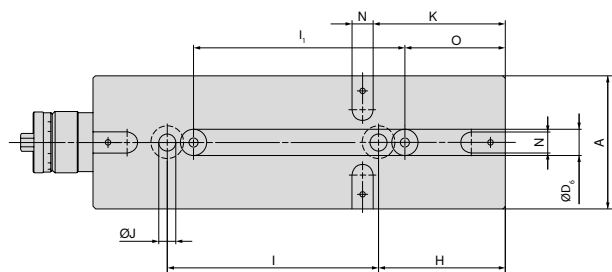

A	H	$I_{\pm 0,015}$	J_{F7}	K	N_{H7}	O	$I_1_{\pm 0,015}$	D_6_{H7}
mm	mm	mm	mm	mm	mm	mm	mm	mm
125	120	200	16	125	20	95	200	25

Šírka základného telesa 160 mm

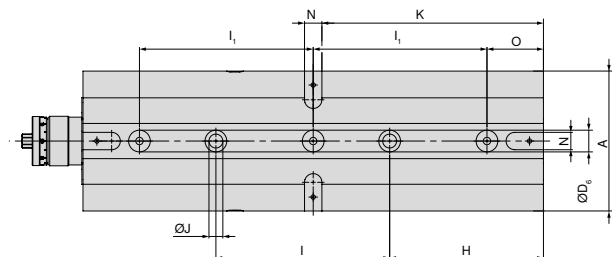

A	H	$I_{\pm 0,015}$	J_{F7}	K	N_{H7}	O	$I_1_{\pm 0,015}$	D_6_{H7}
mm	mm	mm	mm	mm	mm	mm	mm	mm
160	177	200	16	255	20	65	200	25

NCG 5A rozmerová tabuľka pre rôzne usporiadanie čelustí

NCG 5A 100 mm

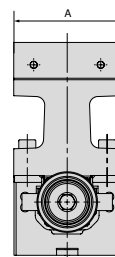
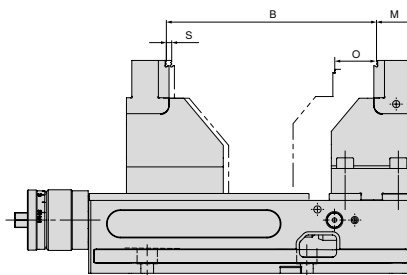
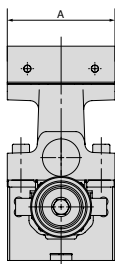
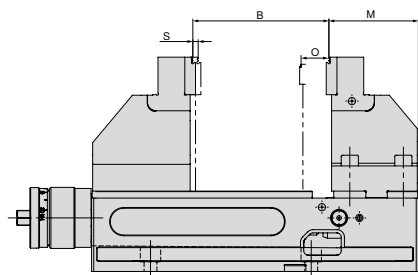

A	B	M	O	S
mm	mm	mm	mm	mm
100	6 - 127	84,5	50	2,5

A	B	M	O	S
mm	mm	mm	mm	mm
100	97 - 199	34,5	50	2,5

NCG 5A 125 mm

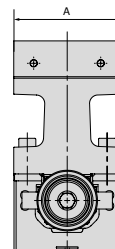
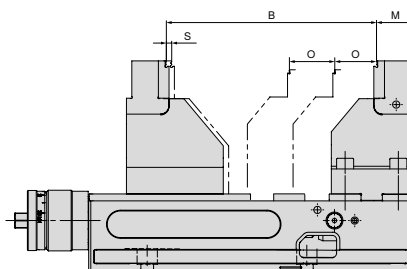
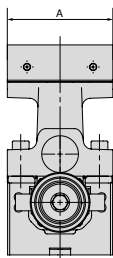
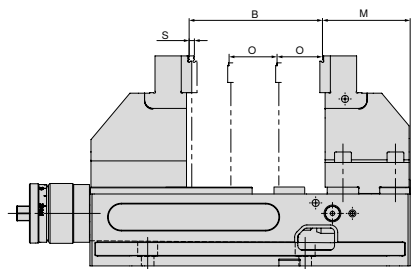

A	B	M	O	S
mm	mm	mm	mm	mm
125	6 - 182	91	55	3

A	B	M	O	S
mm	mm	mm	mm	mm
125	117 - 269	36	55	3

Prehľad systémových čelustí

Kombinovaná otočná čelusť Plus, pevná

- ▲ pre rozšírenie upínacieho rozsahu
- ▲ kalené čeluste
- ▲ vr. upínacích skrutiek
- ▲ cena za kus

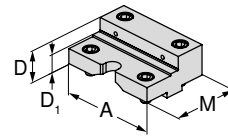

pre šírku zveráka	A	A ₁	D	D ₁	D ₂	E	M	M ₁	M ₂
125	125		39,8	22			88		

EUR

Y4

377,00

80 890 35100

NCG	H5G / -S / -Z	X5G-Z / -S	ESG 4	ESG 5	HDG 2	ZSG 4	ZSG mini	DSG 4	Verso	HSG
•										

Kombinovaná otočná čelusť Plus, pohyblivá

- ▲ pre rozšírenie upínacieho rozsahu
- ▲ kalené čeluste
- ▲ vr. upínacích skrutiek
- ▲ cena za kus

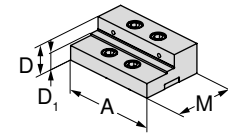

pre šírku zveráka	A	A ₁	D	D ₁	D ₂	E	M	M ₁	M ₂
125	125		39,8	22			82		

EUR

Y4

377,00

80 890 35200

NCG	H5G / -S / -Z	X5G-Z / -S	ESG 4	ESG 5	HDG 2	ZSG 4	ZSG mini	DSG 4	Verso	HSG
•										

Štandardná otočná čelusť, pevná

- ▲ 1 strana hladká, 1 strana drážkovaná
- ▲ vr. upínacích skrutiek
- ▲ cena za kus

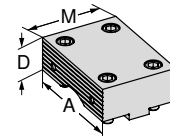

pre šírku zveráka	A	A ₁	D	D ₁	D ₂	E	M	M ₁	M ₂
100	100		34				76		
125	125		39				88		
160	160		49				108		

EUR

Y4

247,00

80 890 323

323,00

80 890 324

407,00

80 890 325

NCG	H5G / -S / -Z	X5G-Z / -S	ESG 4	ESG 5	HDG 2	ZSG 4	ZSG mini	DSG 4	Verso	HSG
•										
•										
•										

Štandardná otočná čelusť, pohyblivá

- ▲ 1 strana hladká, 1 strana drážkovaná
- ▲ vr. upínacích skrutiek
- ▲ cena za kus

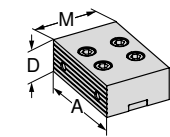

pre šírku zveráka	A	A ₁	D	D ₁	D ₂	E	M	M ₁	M ₂
100	100		34				67		
125	125		39				82		
160	160		49				108		

EUR

Y4

247,00

80 890 327

323,00

80 890 328

407,00

80 890 329

NCG	H5G / -S / -Z	X5G-Z / -S	ESG 4	ESG 5	HDG 2	ZSG 4	ZSG mini	DSG 4	Verso	HSG
•										
•										
•										

Prehľad systémových čelustí

Kombinovaná otočná čelusť, pevná

- ▲ pre rozšírenie upínacieho rozsahu
- ▲ kalené čeluste
- ▲ vr. upínacích skrutiek
- ▲ cena za kus

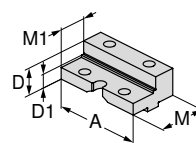

pre šírku zveráka	A	A ₁	D	D ₁	D ₂	E	M	M ₁	M ₂	EUR	Y4	NCG	H5G / -S / -Z	X5G-Z / -S	ESG 4	ESG 5	HDC 2	ZSG 4	ZSG mini	DSG 4	Verso	HSG	
100	100		34	23			76	50		285,00	80 890 343	•											
125	125		39	25			88	50		363,00	80 890 344	•											
160	160		49	28			108	56		446,00	80 890 342	•											

Kombinovaná otočná čelusť, pohyblivá

- ▲ pre rozšírenie upínacieho rozsahu
- ▲ kalené čeluste
- ▲ vr. upínacích skrutiek
- ▲ cena za kus

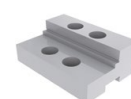
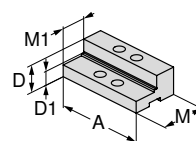

pre šírku zveráka	A	A ₁	D	D ₁	D ₂	E	M	M ₁	M ₂	EUR	Y4	NCG	H5G / -S / -Z	X5G-Z / -S	ESG 4	ESG 5	HDC 2	ZSG 4	ZSG mini	DSG 4	Verso	HSG	
100	100		34	23			67	40		285,00	80 890 347	•											
125	125		39	25			82	45		363,00	80 890 348	•											
160	160		49	28			108	56		446,00	80 890 346	•											

Mäkká čelusť, oceľ, pevná

- ▲ materiál: 16MnCr5
- ▲ pre výrobu tvarových čelustí (možnosť zakalenia)
- ▲ bez upínacích skrutiek
- ▲ cena za kus

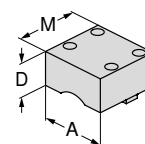

pre šírku zveráka	A	A ₁	D	D ₁	D ₂	E	M	M ₁	M ₂	EUR	Y4	NCG	H5G / -S / -Z	X5G-Z / -S	ESG 4	ESG 5	HDC 2	ZSG 4	ZSG mini	DSG 4	Verso	HSG	
100	100		50				95			143,40	80 890 763	•											
125	125		50				110			149,70	80 890 764	•											

Mäkká čelusť, oceľ, pohyblivá

- ▲ materiál: 16MnCr5
- ▲ pre výrobu tvarových čelustí (možnosť zakalenia)
- ▲ bez upínacích skrutiek
- ▲ cena za kus

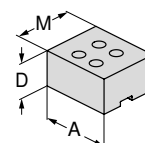

pre šírku zveráka	A	A ₁	D	D ₁	D ₂	E	M	M ₁	M ₂	EUR	Y4	NCG	H5G / -S / -Z	X5G-Z / -S	ESG 4	ESG 5	HDC 2	ZSG 4	ZSG mini	DSG 4	Verso	HSG	
100	100		50				85			143,90	80 890 767	•											
125	125		50				100			151,10	80 890 768	•											

Prehľad systémových čelustí

Upínacia čelusť 5A, pevná

- ▲ so stupňovitou čelustou grip 5 mm
- ▲ cena za kus

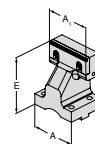

pre šírku zveráka	A	A ₁	D	D ₁	D ₂	E	M	M ₁	M ₂	EUR	Y4	NCG	H5G / -S / -Z	X5G-Z / -S	ESG 4	ESG 5	HDG 2	HDG 4	ZSG 4	ZSG mini	DSG 4	Verso	HSG	
100	100	100				125				554,00	80 890 364	●												
125	125	125				150				666,00	80 890 366	●												

Upínacia čelusť 5A, pohyblivá

- ▲ so stupňovitou čelustou grip 5 mm
- ▲ cena za kus

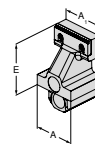

pre šírku zveráka	A	A ₁	D	D ₁	D ₂	E	M	M ₁	M ₂	EUR	Y4	NCG	H5G / -S / -Z	X5G-Z / -S	ESG 4	ESG 5	HDG 2	HDG 4	ZSG 4	ZSG mini	DSG 4	Verso	HSG	
100	100	100				125				589,00	80 890 365	●												
125	125	125				150				730,00	80 890 367	●												

Adaptérová doska, pevná

- ▲ pre upínanie 6násobných výmenných čelustí
- ▲ vr. 6 krycích skrutiek
- ▲ cena za kus

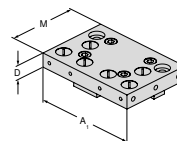

pre šírku zveráka	A	A ₁	D	D ₁	D ₂	E	M	M ₁	M ₂	EUR	Y4	NCG	H5G / -S / -Z	X5G-Z / -S	ESG 4	ESG 5	HDG 2	HDG 4	ZSG 4	ZSG mini	DSG 4	Verso	HSG	
100	100	160	22				110			278,00	80 890 321	●												
125	125	192	22				130			397,00	80 890 337	●												
160	160	256	22				170			521,00	80 890 339	●												

Výkyvná doska, pohyblivá

- ▲ pre upínanie 6násobných výmenných čelustí
- ▲ vr. 6 krycích skrutiek (v prípade A = 100 mm, 4 ks)
- ▲ cena za kus

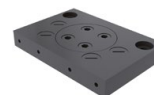
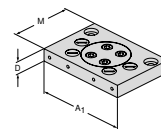

pre šírku zveráka	A	A ₁	D	D ₁	D ₂	E	M	M ₁	M ₂	EUR	Y4	NCG	H5G / -S / -Z	X5G-Z / -S	ESG 4	ESG 5	HDG 2	HDG 4	ZSG 4	ZSG mini	DSG 4	Verso	HSG	
100	100	160	22				110			401,00	80 890 322	●												
125	125	192	22				130			472,00	80 890 338	●												
160	160	256	22				170			582,00	80 890 340	●												

Prehľad systémových čelustí

Ďnásobná otočná čelusť

- ▲ 1 = hladká, s povlakom WC
- ▲ 2 = grip so stupňom 3 mm
- ▲ 3 = grip so stupňom 8 mm
- ▲ 4 = grip so stupňom 18 mm
- ▲ 5 = guľatý grip so stupňom 8 mm
- ▲ 6 = guľatý grip
- ▲ $M_{max} = 60 \text{ Nm}$
- ▲ vr. upínacej skrutky
- ▲ cena za kus

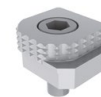
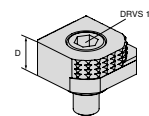

pre šírku zveráka	A	A ₁	D	D ₁	D ₂	E	M	M ₁	M ₂	EUR	Y4	NCG	H5G / -S / -Z	X5G-Z / -S	ESG 4	ESG 5	HDG 2	ZSG 4	ZSG mini	DSG 4	Verso	HSG	
			18							80,60	80 892 246	●	●	●	●				●	●	●	●	

Ďnásobná otočná čelusť, karbid grip

- ▲ 1 = hladká
- ▲ 2 = karbidový grip
- ▲ 3 = karbidový grip so stupňom 3 mm
- ▲ 4 = karbidový grip so stupňom 8 mm
- ▲ 5 = karbidový guľatý grip so stupňom 8 mm
- ▲ 6 = karbidový guľatý grip
- ▲ vr. upínacej skrutky
- ▲ cena za kus

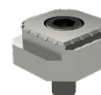
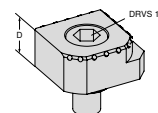

pre šírku zveráka	A	A ₁	D	D ₁	D ₂	E	M	M ₁	M ₂	EUR	Y4	NCG	H5G / -S / -Z	X5G-Z / -S	ESG 4	ESG 5	HDG 2	ZSG 4	ZSG mini	DSG 4	Verso	HSG	
			18							117,00	80 890 35300	●	●	●	●				●	●	●	●	

Prehľad systémového príslušenstva

Vretenová matica

▲ pre prestavbu NCG 5AC na typ NCG

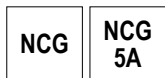

Pre šírku mm	80 890 ... EUR Y4	
100	186,00	385
125	197,00	387
160	224,00	389

Úchytka

▲ pre jednoduchú a bezpečnú prepravu

Rozsah dodávky:

1 ks úchytka vr. upínacích skrutiek

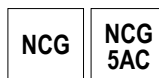

Pre šírku mm	80 890 ... EUR Y4	
100/125	18,20	685

Predĺženie tiaha

▲ pre spojenie 2 upínacích zverákov NCG

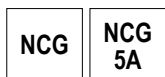

Pre šírku mm	B mm	80 890 ... EUR Y4	
100	305 - 460	318,00	460
125	390 - 602	349,00	470

Ochranná doštička

▲ pre pohyblivú štandardnú čelusť, kombinovanú otočnú čelusť a kombinovanú otočnú čelusť plus

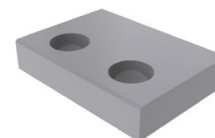
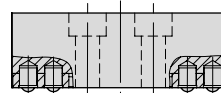

Pre šírku mm	80 890 ... EUR Y4	
100	4,60	010
125	3,50	012
160	35,00	013

Súprava plechových krytov

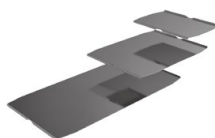
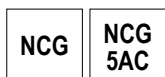

Pre šírku mm	80 890 ... EUR Y4	
100	27,10	442
125	31,00	443
160	32,40	444

Tlačný element pre ochrannú doštičku



Pre šírku mm	80 890 ... EUR Y4	
100/125	2,30	008
160	2,30	014

Prehľad systémového príslušenstva

Upínacia páka

▲ vr. príslušenstva

NCG	NCG 5A
H5G	



Pre šírku mm	DRVS mm	80 890 ...
100/125/160	14	EUR Y4 128,00 501

Kľučka pre rýchle nastavenie

▲ pre rýchlejšie nastavenie rozsahu upínania
s odnímateľnou vonkajšou rukoväťou

NCG	NCG 5AC
-----	------------



Pre šírku mm	80 890 ...
100	EUR Y4 63,20 550
125/160	75,10 551

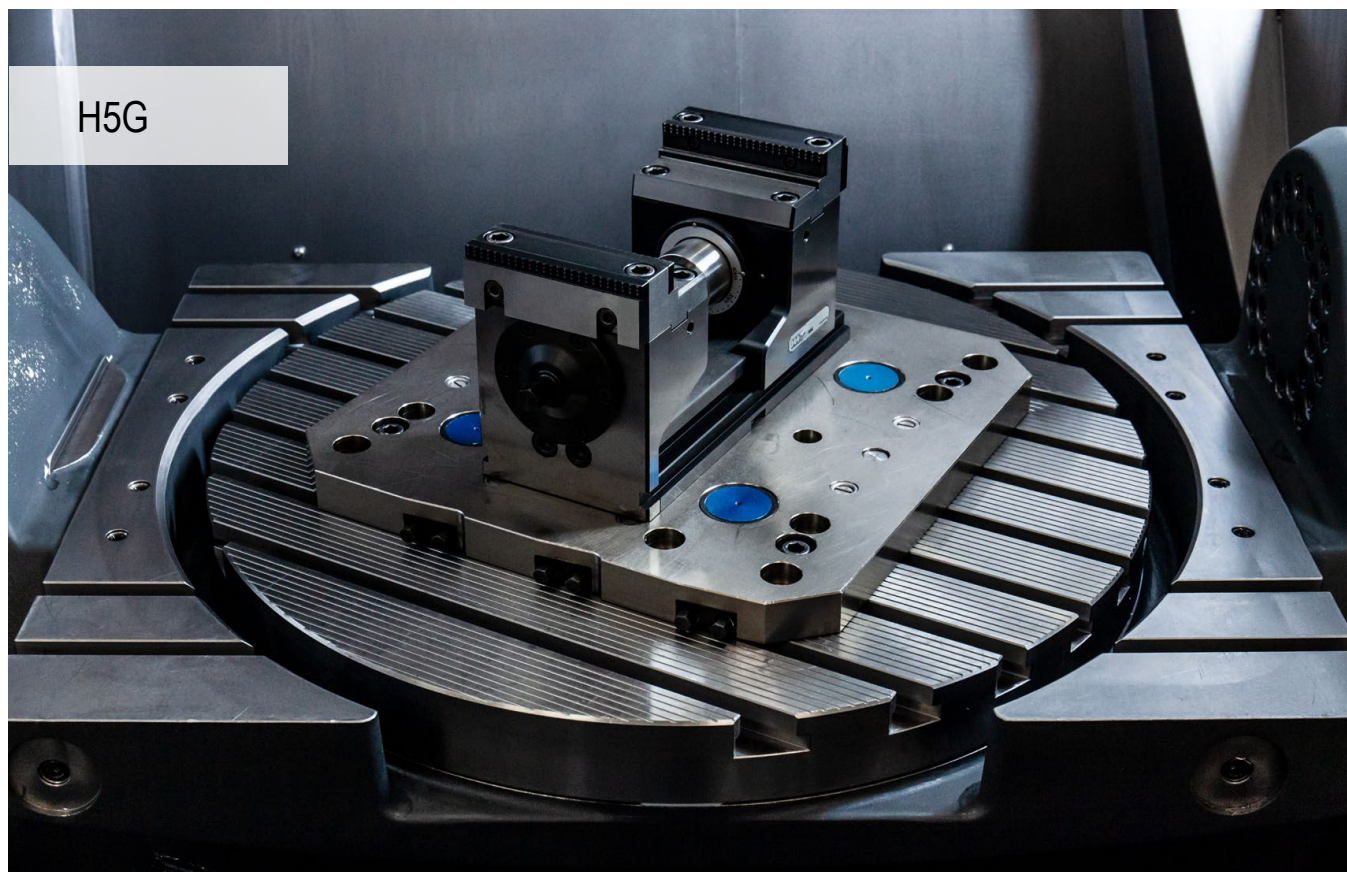

Optimalizovaný 5osový upínací systém

Upínací systém s posilňovačom pre „skutočné“ 5osové kompletne a simultánne obrobenie. Opracovanie obróbku z prvej i druhej strany, upínanie ťahom silou až 40kN, upínanie vreteno tesne pod obrábkom.

Výhody pre Vás:

- ▲ rýchla prestavba – zmena nastavenia kompletneho upínacieho rozsahu za pár sekúnd
- ▲ rýchle polohovanie pomocou MNG na strojnom stole bez adaptérovej dosky
- ▲ možnosť plynulého nastavenia upínacej sily od 4 – 40 kN
- ▲ rýchle upínanie – 160°
- ▲ otočenie čelustou – jednoduchšia a rýchlejšia výmena čeluste pomocou 4 skrutiek
- ▲ jednoduché čistenie, vreteno je kompletne zapuzdrené
- ▲ široká paleta čelustí a príslušenstva



Upnutie / Vyrovnávanie:

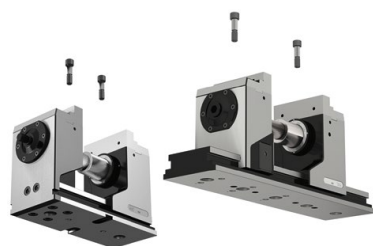

Upínanie pomocou dvoch lícovaných skrutiek
Ø 12_{H7} / M12 Artikel č. 80 895 019



Vyrovnávanie pomocou kameňov lícovaných do drážok š. 20^{H7} v základnom telese (u H5G), lebo pomocou súpravy pre polohovanie v T drážkach š. 14 / 16 / 18 mm ve stole stroja. Upnutie pomocou úpiniek.



Vyrovnávanie a upnutie pomocou upínacieho systému s nulovým bodom MNG (2-3 upínacie čapy). **Variante:** Polohovacie a upínacie otvory na želanie zákazníka.

Vyrovnanie predĺžovacieho základného telesa:



- ▲ namontujte samostatné predĺžovacie základné teleso
- ▲ vzdialenosť od hlavného základného telesa 0,2 – 10 mm
- ▲ na obidve základné telesá nasuňte pohyblivú upínaciu čelusť
- ▲ predĺžovacie základné teleso vyrovnajte paralelne s hlavným základným telesom
- ▲ upnite predĺžovacie základné teleso

Montáž predĺženia tiahla:

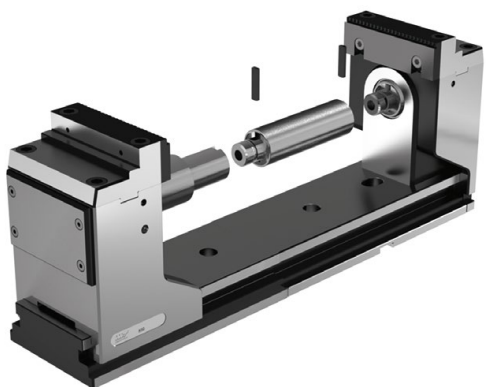

- ▲ namontujte predĺžovacie základné teleso (vyrovnanie vid' vyššie)
- ▲ na vreteno naskrutkujte predĺženie tiahla
- ▲ založte prvý poistný kolík
- ▲ na predĺžovacie základné teleso nasuňte pohyblivú upínaciu čelusť
- ▲ predĺžené tiahlo spojte s pevnou upínacou čelusťou
- ▲ založte druhý poistný kolík

Funkčný princíp mobilnej pevnej čelusti:

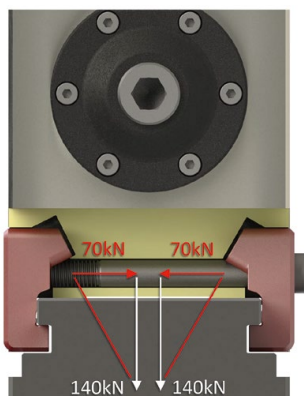

Dvojnásobné pôsobenie skrutky = Dvojitá sila
Šikmé plochy = Dvojitá sila

U zveráka H5G-Z a H5G-Z-S je možné obidve upínacie čeluste posunovať ľubovoľne. Mobilnú pevnú čelusť je možné v ľubovoľnej polohe na základnom telese upnúť pomocou 1 alebo 2 skrutiek (1 = H5G-Z / 2 = H5G-Z-S) (uťahovací moment pre skrutky = 90 Nm). Prídružná sila pevnej čeluste je takmer rovnaká ako u H5G, ktorý je pripevnený pomocou štyroch skrutiek.

SoloClamp – H5G

- ▲ 5osový strojný zverák s rýchlym nastavením, upínacia výška 174 mm
- ▲ rýchle upnutie pákou v rozsahu do 160°
- ▲ rýchle nastavenie rozsahu upínania
- ▲ 100 % zapuzdrenie
- ▲ základna zveráku s pozdĺžnymi a priečnymi drážkami 20 H7 a lícovanými otvormi Ø 12 F7

Rozsah dodávky:

Zverák vr. 4 upínacích pätiček, ručnej kľuky a upínacej páky

H5G

MNG

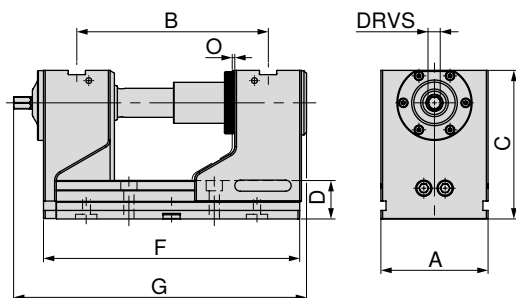

80 898 ...

EUR
Y4

3.180,00 125

A	B	C	D	F	G	O	DRVS	MXC	WT
mm	mm	mm	mm	mm	mm	mm	mm	kN	kg
125	97 - 223	174	45	300	336,5	1	14	40	30,2

SoloClamp – H5G

- ▲ 5osový strojný zverák, dlhé prevedenie, upínacia výška 174 mm

H5G

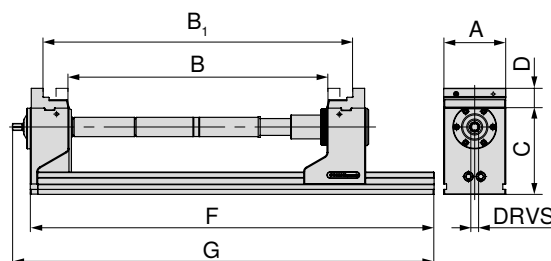
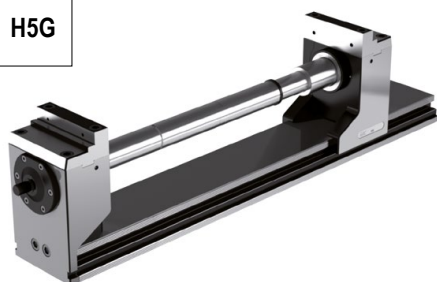

A	C	D	F	G	DRVS	Upínacia sila
mm	mm	mm	mm	mm	mm	kN
125	174	40	815	851	14	40

B	B ₁	Artikel č.
0 – 126	123 – 251	80 898 125
125 – 252	248 – 374	80 898 125 + 80 898 826 + 80 898 725
250 – 376	372 – 499	80 898 125 + 80 898 827 + 80 898 725
375 – 501	498 – 624	80 898 125 + 80 898 826 + 80 898 827 + 80 898 725
500 – 626	622 – 749	80 898 125 + 2 x 80 898 827 + 80 898 725



Zverák H5G 125 mm je možné rozšíriť maximálne o 2 predĺženia ľažnej tyče po 250 mm. Strata upínacej sily na predĺženie činí cca 10%.
Základná doska v dlhom prevedení s požadovanou schémou rozloženia vŕtaných otvorov **iba na želanie**.

Prehľad zverákov

Rozmery spodnej strany	27	Rozmerové tabuľky pre rôzne čeľuste	28–32
Systemové príslušenstvo	33–36	Upínací systém s nulovým bodom MNG/PNG	134–163
Obecné príslušenstvo	164–183		

SoloClamp – H5G-S

- ▲ 5osový strojný zverák s rýchlonastavením, upínacia výška 125 mm
- ▲ rýchle upnutie pákou v rozsahu do 160°
- ▲ rýchle nastavenie rozsahu upínania
- ▲ 100 % zapuzdrenie
- ▲ dĺžka F = 300 mm so strediacim otvorom Ø 25 H7
- ▲ dĺžka F = 265 mm so strediacim otvorom Ø 32 H6
- ▲ základna zveráku s pozdĺžnymi a priečnymi drážkami 20 H7 a lícovanými otvormi Ø 12 F7

Rozsah dodávky:

Zverák vr. 4 upínacích pätiiek, ručnej kľuky a upínacej páky

H5G
-S

MNG

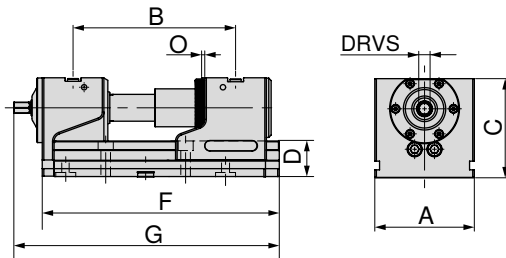

A	B	C	D	F	G	O	DRVS	MXC	WT
mm	mm	mm	mm	mm	mm	mm	mm	kN	kg
125	97 - 186	125	45	265	301,5	1	14	40	21,0
125	97 - 223	125	45	300	336,5	1	14	40	22,6

80 898 ...

EUR
Y42.910,00 123 ¹⁾
2.980,00 124

1) Nie je normovaný

SoloClamp – H5G-S

- ▲ 5osový strojný zverák, dlhé prevedenie, upínacia výška 125 mm

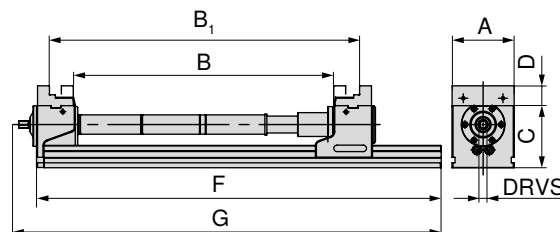
H5G
-S

A	C	D	F	G	DRVS	Upínacia sila
mm	mm	mm	mm	mm	mm	kN
125	125	40	815	851	14	40

B	B ₁	Artikel č.
0 – 126	123 – 250	80 898 124
125 – 251	248 – 374	80 898 124 + 80 898 826 + 80 898 725
250 – 376	372 – 499	80 898 124 + 80 898 827 + 80 898 725
375 – 501	498 – 624	80 898 124 + 80 898 826 + 80 898 827 + 80 898 725
500 – 626	622 – 749	80 898 124 + 2 x 80 898 827 + 80 898 725



Zverák H5G 125 mm je možné rozšíriť maximálne o 2 predĺženia ťažnej tyče po 250 mm. Strata upínacej sily na predĺženie činí cca 10%.
Základná doska v dlhom prevedení s požadovanou schémou rozloženia vŕtaných otvorov **iba na želanie**.

Prehľad zverákov

Rozmery spodnej strany	27	Rozmerové tabuľky pre rôzne čeluste	28–32
Systémové príslušenstvo	33–36	Upínací systém s nulovým bodom MNG/PNG	134–163
Obečné príslušenstvo	164–183		

SoloClamp – H5G-Z

- ▲ 5osový strojný zverák s posuvnou pevnou čelustou, upínacia výška 174 mm
- ▲ rýchle upnutie obrobku upínacou pákou v rozsahu do 160°
- ▲ rýchle nastavenie rozsahu upínania
- ▲ 100 % zapuzdrenie
- ▲ upínanie na stole je možné vykonávať pomocou MNG/PNG alebo priamo cez základné teleso

Rozsah dodávky:

Zverák vr. upínacieho kľúča so šesťhranom

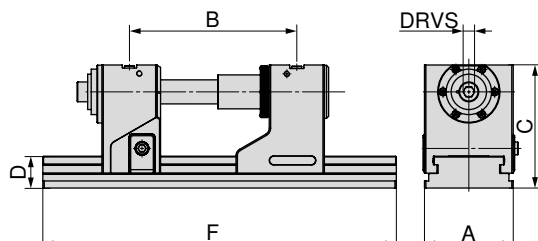

A	B $\pm 0,015$	C	D	F	DRVS	MXC	WT
mm	mm	mm	mm	mm	mm	kN	kg
125	131 - 246	174	45	330	14	40	32,5
125	131 - 352	174	45	430	14	40	36,0
125	131 - 422	174	45	500	14	40	38,5
125	131 - 552	174	45	630	14	40	43,0

80 907 ...

EUR
Y4

3.590,00 12800

3.650,00 125

3.810,00 126

4.130,00 127



→ Strana 36

Pre maximálny upínací rozsah je nutné použiť prídavné predĺženie tiaha.

SoloClamp – H5G-Z-S

- ▲ 5osový strojný zverák s posuvnou pevnou čelustou, upínacia výška 125 mm
- ▲ rýchle upnutie obrobku upínacou pákou v rozsahu do 160°
- ▲ rýchle nastavenie rozsahu upínania
- ▲ 100 % zapuzdrenie
- ▲ upínanie na stole je možné vykonávať pomocou MNG/PNG alebo priamo cez základné teleso

Rozsah dodávky:

Zverák vr. upínacieho kľúča so šesťhranom

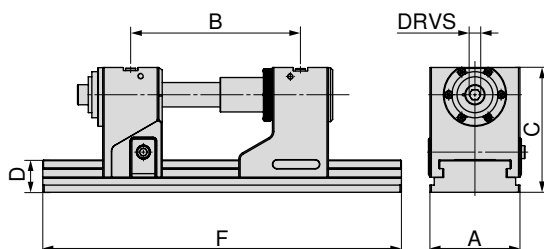

A	B $\pm 0,015$	C	D	F	DRVS	MXC	WT
mm	mm	mm	mm	mm	mm	kN	kg
125	131 - 246	125	45	330	14	40	24,5
125	131 - 352	125	45	430	14	40	28,5
125	131 - 422	125	45	500	14	40	30,5
125	131 - 552	125	45	630	14	40	35,5

80 907 ...

EUR
Y4

3.380,00 22500

3.430,00 22600

3.610,00 22700

3.930,00 22800

Rozmery spodnej strany H5G/H5G-Z

Šírka základného telesa 125 mm,
dĺžka 265 mm

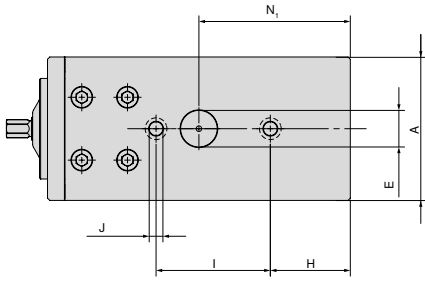

A	E _{H6}	H	I _{±0,015}	J _{F7}	N ₁
125	32	70	100	12	132,5

Šírka základného telesa 125 mm,
dĺžka 430 mm

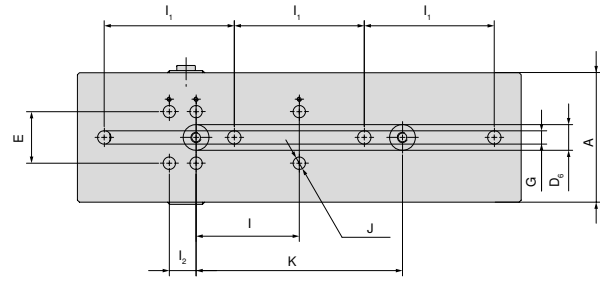

A	E _{±0,01}	I _{1 ±0,3}	I ₂	I _{±0,015}	K _{±0,015}	J _{H7}	G	D _{6 H6}
125	50	126	26	100	200	12	13	25



H5G s dĺžkou 265 mm nie je kompatibilný s MNG.

Šírka základného telesa 125 mm,
dĺžka 300 mm

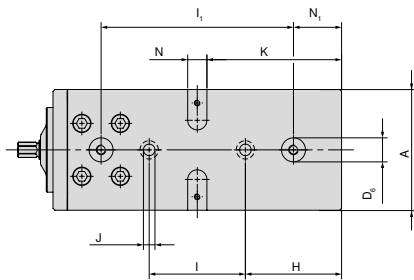

A	D _{6 H7}	H	I _{±0,015}	J _{F7}	K	N _{H7}	I _{1 ±0,015}	N ₁
125	25	100	100	12	140	20	200	50

Šírka základného telesa 125 mm,
dĺžka 500 mm

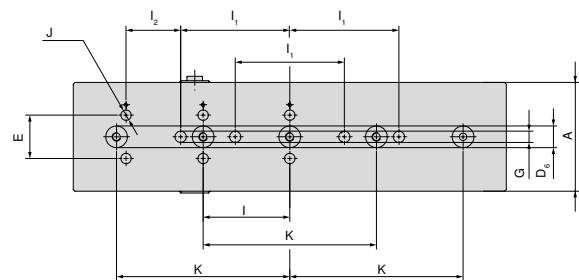

A	E _{±0,01}	I _{1 ±0,3}	I _{±0,015}	K _{±0,015}	I ₂	G	D _{6 H6}	J _{H7}
125	50	126	100	200	63	13	25	12

Šírka základného telesa 125 mm,
dĺžka 330 mm

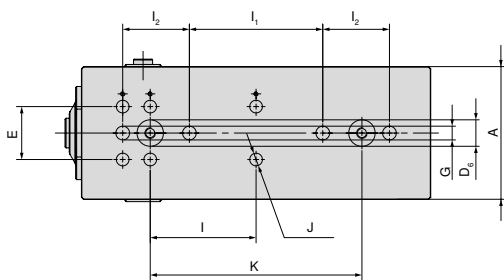

A	E _{±0,01}	I _{±0,015}	I ₂	I _{1 ±0,3}	D _{6 H6}	J _{H7}	K _{±0,015}	G
125	50	100	26	126	25	12	200	13

Šírka základného telesa 125 mm,
dĺžka 630 mm

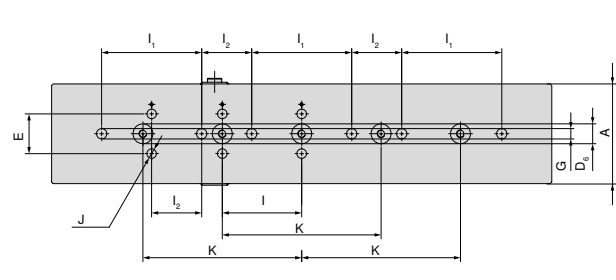

A	E _{±0,01}	I _{1 ±0,3}	I ₂	I _{±0,015}	K _{±0,015}	G	D _{6 H6}	J _{H7}
125	50	126	63	100	200	13	25	12

H5G/H5G-S – Rozmerová tabuľka pre rôzne čeluste

S kombinovanými čelustami

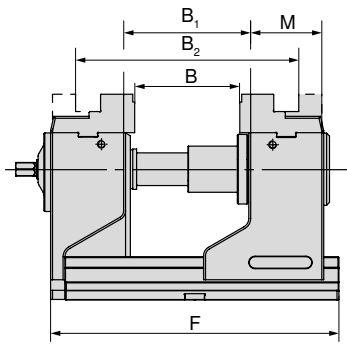

F	B	B ₁	B ₂	M	Artikel č.
mm	mm	mm	mm	mm	Systémové čeluste
265	0 - 89	22 - 112	123 - 212	76	80 898 225
300	0 - 126	22 - 149	123 - 249	76	80 898 225

H5G

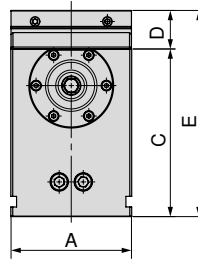

A	C	D	E
mm	mm	mm	mm
-	-	-	-
125	174	40	214

H5G-S

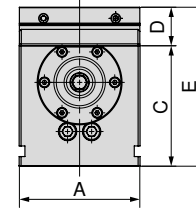

A	C	D	E
mm	mm	mm	mm
125	125	40	165
125	125	40	165

S výmennými čelustami 5A, šírka čeluste 65 mm

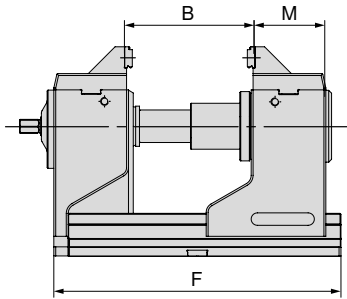

F	B	M	Artikel č.
mm	mm	mm	Systémové čeluste
265	16 - 105	79,5	80 898 325
300	16 - 142	79,5	80 898 325

H5G

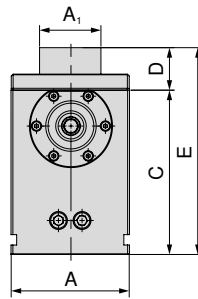

A	A ₁	C	D	E
mm	mm	mm	mm	mm
-	-	-	-	-
125	65	174	45	219

H5G-S

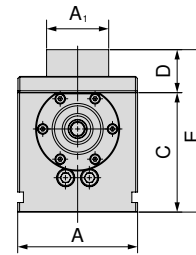

A	A ₁	C	D	E
mm	mm	mm	mm	mm
125	65	125	45	170
125	65	125	45	170

S výmennými čelustami 5A, šírka čeluste 125 mm

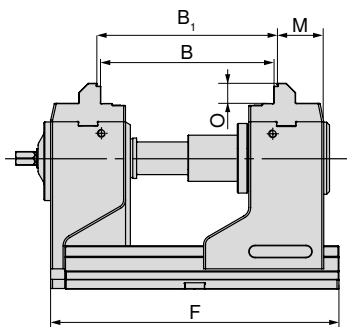

F	B	B ₁	O	M	Artikel č.
mm	mm	mm	mm	mm	Systémové čeluste
265	74 - 162	80 - 168	21	49	80 907 300
300	74 - 199	80 - 205	21	49	80 907 300

H5G

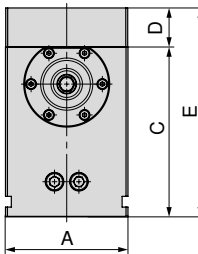

A	C	D	E
mm	mm	mm	mm
-	-	-	-
125	174	40	214

H5G-S

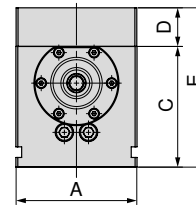

A	C	D	E
mm	mm	mm	mm
125	125	40	165
125	125	40	165

H5G/H5G-S – Rozmerová tabuľka pre rôzne čeluste

S mäkkými čelustami

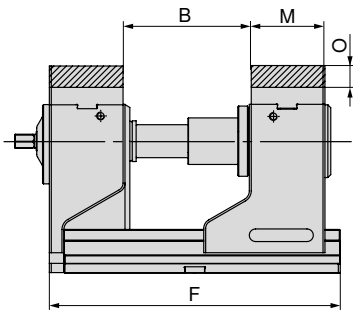

F	B	O	M	Artikel č.
mm	mm	mm	mm	Systémové čeluste
265	23 - 112	22	76	80 898 625
300	23 - 149	22	76	80 898 625

H5G

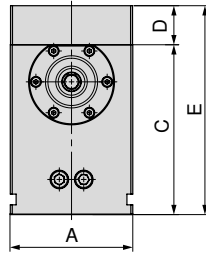

A	C	D	E
mm	mm	mm	mm
-	-	-	-
125	174	40	214

H5G-S

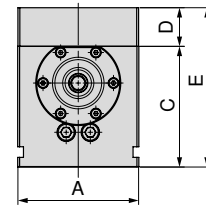

A	C	D	E
mm	mm	mm	mm
125	125	40	165
125	125	40	165

S otočnými čelustami, grip 3 mm

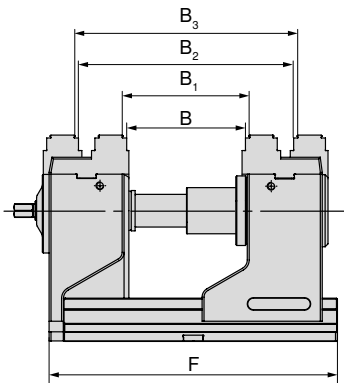

F	B	B ₁	B ₂	B ₃	Artikel č.
mm	mm	mm	mm	mm	Systémové čeluste
265	17 - 106	23 - 112	117 - 206	123 - 212	80 898 35000
300	17 - 140	23 - 146	117 - 240	123 - 246	80 898 35000

H5G

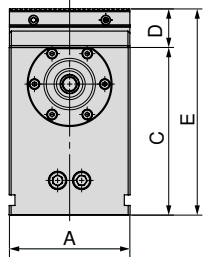

A	C	D	E
mm	mm	mm	mm
-	-	-	-
125	174	40	214

H5G-S

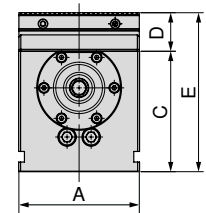

A	C	D	E
mm	mm	mm	mm
125	125	40	165
125	125	40	165

S výkyvnou a adaptérovou čelustou

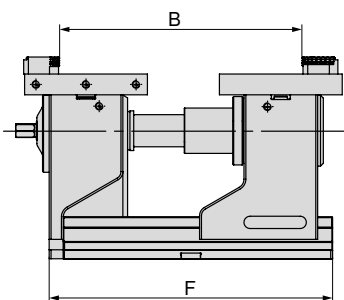

F	B	Artikel č.
mm	mm	Systémové čeluste
265	17 - 236	80 898 525 + 80 898 425
300	17 - 274	80 898 525 + 80 898 425

H5G

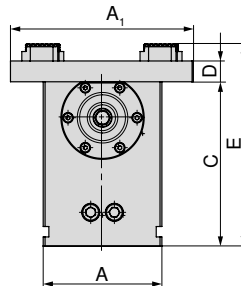

A	A ₁	C	D	E
mm	mm	mm	mm	mm
-	-	-	-	-
125	192	174	22	214

H5G-S

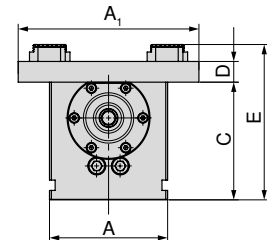

A	A ₁	C	D	E
mm	mm	mm	mm	mm
125	192	125	22	165
125	192	125	22	165

H5G/H5G-S – Rozmerová tabuľka pre rôzne čeluste

So systémom 6 násobných čelustí

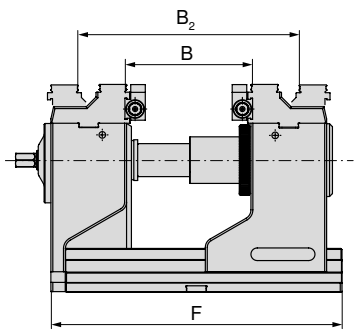

F	B	B ₂	O	M	Artikel č.
mm	mm	mm	mm	mm	Systémové čeluste
265	39-115	119-191	22	76	80 898 230
300	39-152	119-228	22	76	80 898 230

H5G

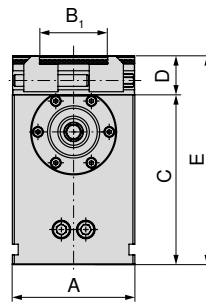

A	B ₁	C	D	E
mm	mm	mm	mm	mm
-	-	-	-	-
125	37-101	174	40	214

H5G-S

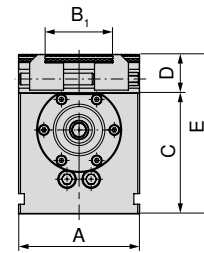

A	B ₁	C	D	E
mm	mm	mm	mm	mm
125	37-101	125	40	165
125	37-101	125	40	165

H5G-Z/-S – Rozmerová tabuľka pre rôzne čeluste

S kombinovanými čelustami

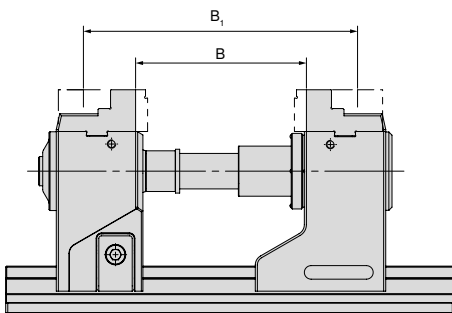

Variant	B	B ₁	Artikel č.
	mm	mm	Systémové čeluste
H5G-Z	57-182	157-282	80 898 225
H5G-Z-S	47-172	147-272	80 898 225

H5G-Z

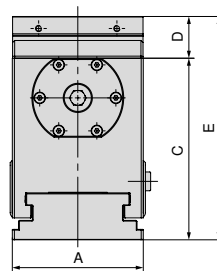

A	C	D	E
mm	mm	mm	mm
125	174	40	214
-	-	-	-

H5G-Z-S

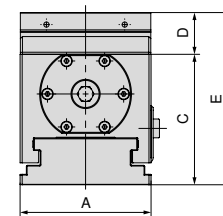

A	C	D	E
mm	mm	mm	mm
-	-	-	-
125	125	40	165

S výmennými stupňovitými čelustami 5A

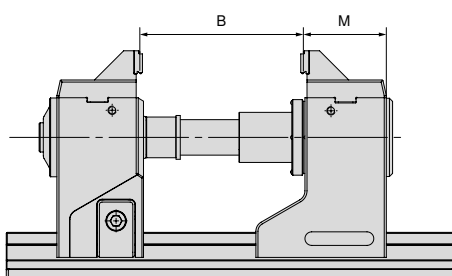

Variant	B	M	Artikel č.
	mm	mm	Systémové čeluste
H5G-Z	50-175	74	80 898 325
H5G-Z-S	40-165	74	80 898 325

H5G-Z

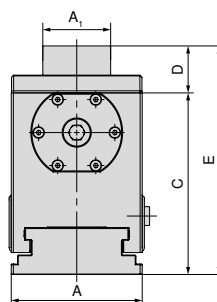

A	A ₁	C	D	E
mm	mm	mm	mm	mm
125	65	174	45	214
-	-	-	-	-

H5G-Z-S

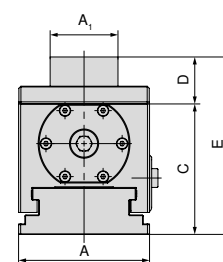

A	A ₁	C	D	E
mm	mm	mm	mm	mm
-	-	-	-	-
125	65	125	45	165

H5G-Z/-S – Rozmerová tabuľka pre rôzne čeluste

S otočnou čelustou grip 3 mm, hladká, stupeň 16 mm

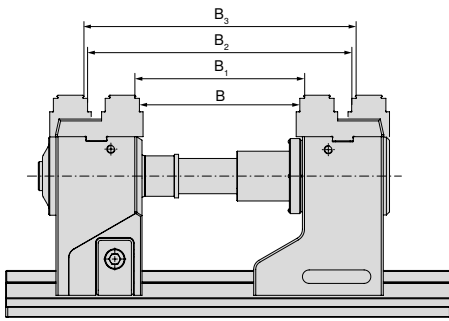

Variant	B mm	B ₁ mm	B ₂ mm	B ₃ mm	Artikel č. Systémové čeluste
H5G-Z	48-173	54-179	148-273	154-279	2 x 80 898 35000
H5G-Z-S	38-173	44-169	138-263	144-269	2 x 80 898 35000

H5G-Z

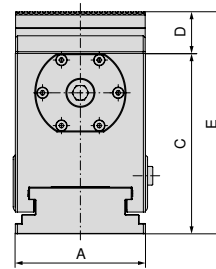

A mm	C mm	D mm	E mm
125	174	40	214
-	-	-	-

H5G-Z-S

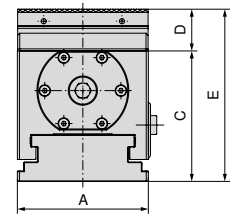

A mm	C mm	D mm	E mm
-	-	-	-
125	125	40	165

S výmennou čelustí 5A, šírka čeluste 125 mm

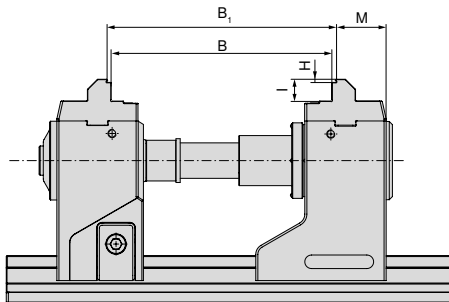

Variant	B mm	B ₁ mm	H mm	I mm	M mm	Artikel č. Systémové čeluste
H5G-Z	105-230	111-236	3	21	48,7	2 x 80 907 300
H5G-Z-S	95-220	101-226	3	21	48,7	2 x 80 907 300

H5G-Z

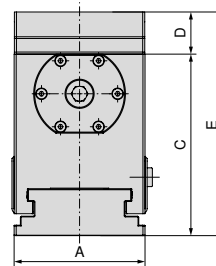

A mm	C mm	D mm	E mm
125	174	40	214
-	-	-	-

H5G-Z-S

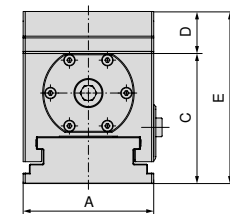

A mm	C mm	D mm	E mm
-	-	-	-
125	125	40	165

S mäkkými čelustami

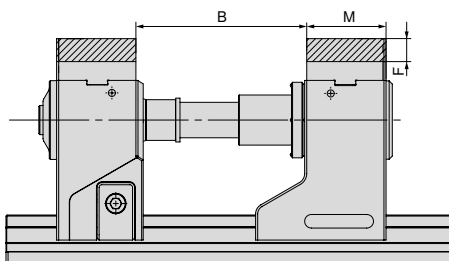

Variant	B mm	F mm	M mm	Artikel č. Systémové čeluste
H5G-Z	57-182	22	76	80 898 625
H5G-Z-S	47-172	22	76	80 898 625

H5G-Z

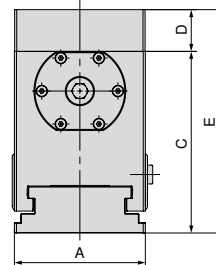

A mm	C mm	D mm	E mm
125	174	40	214
-	-	-	-

H5G-Z-S

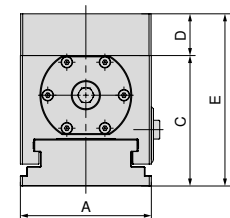

A mm	C mm	D mm	E mm
-	-	-	-
125	125	40	165

H5G-Z/-S – Rozmerová tabuľka pre rôzne čeluste

S výkyvnou a adaptérovou čelustou

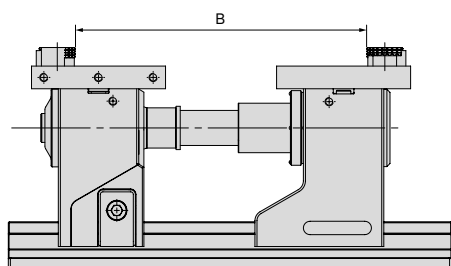

Variant	B mm	Artikel č. Systémové čeluste
H5G-Z	11 - 300	80 898 525 + 80 898 425
H5G-Z-S	11 - 290	80 898 525 + 80 898 425

H5G-Z

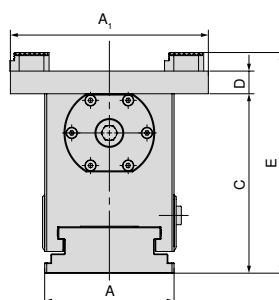

A mm	A ₁ mm	C mm	D mm	E mm
125	192	174	40	214
-	-	-	-	-

H5G-Z-S

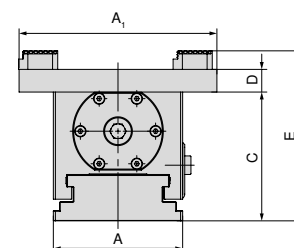

A mm	A ₁ mm	C mm	D mm	E mm
-	-	-	-	-
125	192	125	40	165

So systémom 6 násobných čelustí

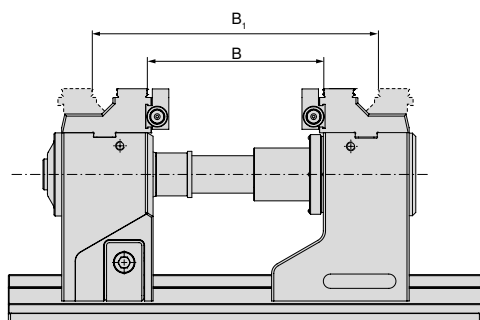

Variant	B mm	B ₂ mm	Artikel č. Systémové čeluste
H5G-Z	52 - 177	152 - 277	80 898 230
H5G-Z-S	42 - 167	142 - 267	80 898 230

H5G-Z

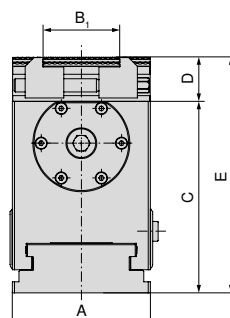

A mm	B ₁ mm	C mm	D mm	E mm
125	37 - 101	174	40	214
-	-	-	-	-

H5G-Z-S

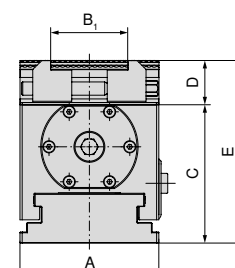

A mm	B ₁ mm	C mm	D mm	E mm
-	-	-	-	-
125	37 - 101	125	40	165



Upínacie rozsahy sa vzťahujú i na základné telesá 500 mm a 630 mm. Rozšírené rozsahy upínania je možné využívať pomocou predĺženia tiaha. Uvádzaných upínacích rozsahov je možné niekedy dosiahnuť iba pomocou výmenných čelustí.

Prehľad systémových čelustí

5osová výmenná, stupňovitá čelusť

- ▲ výmenná čelusť 125/65 mm vr. stupňovitá čeluste grip 3 mm
- ▲ cena za kus

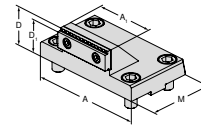

pre šírku zveráka	A	A ₁	D	D ₁	D ₂	E	M	M ₁	M ₂
125	125	65	45	42			76		

EUR

Y4

377,00

80 898 325

NCG	H5G / -S / -Z	X5G-Z / -S	ESG 4	ESG 5	HDG 2	ZSG 4	ZSG mini	DSG 4	Verso	HSG
	●									

5osová výmenná čelusť

- ▲ lepší prístup vďaka skosenej zadnej strane
- ▲ cena za kus

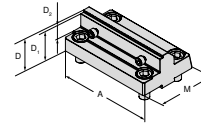

pre šírku zveráka	A	A ₁	D	D ₁	D ₂	E	M	M ₁	M ₂
125	125		40	37	18		78		

EUR

Y4

354,00

80 907 300

NCG	H5G / -S / -Z	X5G-Z / -S	ESG 4	ESG 5	HDG 2	ZSG 4	ZSG mini	DSG 4	Verso	HSG
	●									

Kombinovaná otočná čelusť

- ▲ pre rozšírenie upínacieho rozsahu
- ▲ cena za kus

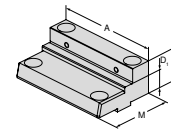

pre šírku zveráka	A	A ₁	D	D ₁	D ₂	E	M	M ₁	M ₂
125	125		40	22			76		

EUR

Y4

377,00

80 898 225

NCG	H5G / -S / -Z	X5G-Z / -S	ESG 4	ESG 5	HDG 2	ZSG 4	ZSG mini	DSG 4	Verso	HSG
	●									

Mäkká hliníková čelusť

- ▲ pre výrobu tvarových čelustí
- ▲ cena za kus

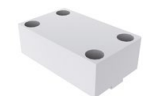
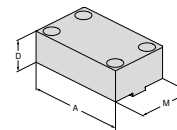

pre šírku zveráka	A	A ₁	D	D ₁	D ₂	E	M	M ₁	M ₂
125	125		40				76		

EUR

Y4

111,00

80 898 625

NCG	H5G / -S / -Z	X5G-Z / -S	ESG 4	ESG 5	HDG 2	ZSG 4	ZSG mini	DSG 4	Verso	HSG
	●									

Prehľad systémových čelustí

Otočná čelusť – grip 3 mm, hladký stupeň 16 mm, obojstranná

▲ cena za kus

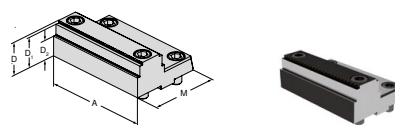

pre šírku zveráka	A	A ₁	D	D ₁	D ₂	E	M	M ₁	M ₂
125	125		40	37	24		82,5		

EUR

Y4

399,00

80 898 35000

NCG	H5G / -S / -Z	X5G-Z / -S	ESG 4	ESG 5	HDG 2	ZSG 4	ZSG mini	DSG 4	Verso	HSG
	●									

Výkyvná doska, pohyblivá

▲ pre upínanie 6násobných otočných čelustí

▲ cena za kus

▲ vr. krycích skrutiek

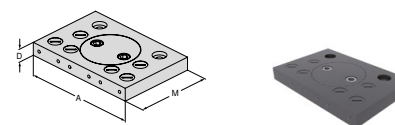

pre šírku zveráka	A	A ₁	D	D ₁	D ₂	E	M	M ₁	M ₂
125	192		22				130		

EUR

Y4

491,00

80 898 525

NCG	H5G / -S / -Z	X5G-Z / -S	ESG 4	ESG 5	HDG 2	ZSG 4	ZSG mini	DSG 4	Verso	HSG
	●									

Adaptérová doska, pevná

▲ pre upínanie 6násobných otočných čelustí

▲ cena za kus

▲ vr. krycích skrutiek

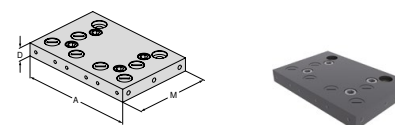

pre šírku zveráka	A	A ₁	D	D ₁	D ₂	E	M	M ₁	M ₂
125	192		22				130		

EUR

Y4

414,00

80 898 425

NCG	H5G / -S / -Z	X5G-Z / -S	ESG 4	ESG 5	HDG 2	ZSG 4	ZSG mini	DSG 4	Verso	HSG
	●									

6násobná otočná čelusť

▲ 1 = hladká, s povlakom WC

▲ 2 = grip so stupňom 3 mm

▲ 3 = grip so stupňom 8 mm

▲ 4 = grip so stupňom 18 mm

▲ 5 = guľatý grip so stupňom 8 mm

▲ 6 = guľatý grip

▲ M_{max} = 60 Nm

▲ vr. upínacej skrutky

▲ cena za kus

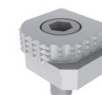
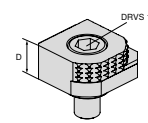

pre šírku zveráka	A	A ₁	D	D ₁	D ₂	E	M	M ₁	M ₂
			18						

EUR

Y4

80,60

80 892 246

NCG	H5G / -S / -Z	X5G-Z / -S	ESG 4	ESG 5	HDG 2	ZSG 4	ZSG mini	DSG 4	Verso	HSG
●	●	●	●			●		●	●	

Prehľad systémových čelustí

6násobná otočná čelusť, karbid grip

- ▲ 1 = hladká
- ▲ 2 = karbidový grip
- ▲ 3 = karbidový grip so stupňom 3 mm
- ▲ 4 = karbidový grip so stupňom 8 mm
- ▲ 5 = karbidový guľatý grip so stupňom 8 mm
- ▲ 6 = karbidový guľatý grip
- ▲ vr. upínacej skrutky
- ▲ cena za kus

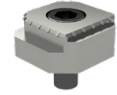
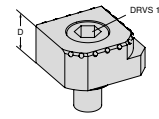

pre šírku zveráka	A	A ₁	D	D ₁	D ₂	E	M	M ₁	M ₂	EUR	Y4	NCG	H5G / -S / -Z	X5G-Z / -S	ESG 4	ESG 5	HDG 2	ZSG 4	ZSG mini	DSG 4	Verso	H5G	
			18							117,00	80 890 35300	●	●	●	●				●	●	●	●	

6násobné systémové čeluste pre šírku 125 mm

Rozsah dodávky:

2 systémové čeluste s 2 páriami priečnych čelustí s T-drážkou vr. upínacích skrutiek

H5G
-S

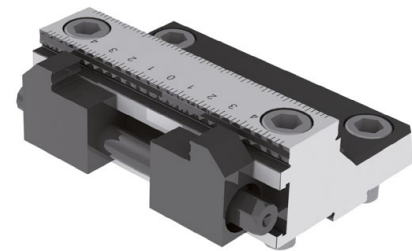
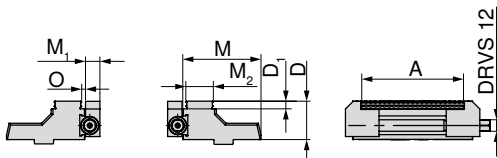

Pre šírku mm	A mm	D mm	D ₁ mm	M mm	M ₁ mm	M ₂ mm	O mm	WT kg	80 898 ...
125	37 - 101	40	8	81,5	15	28,7	3,2	4,5	EUR Y4 1.760,00 230

Prehľad systémového príslušenstva

Predĺženie tiaha

▲ vr. poistného kolíka

H5G

H5G-S

H5G-Z

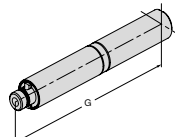



80 898 ...

G	mm	EUR	Y4
125		360,00	826
250		408,00	827

Záslepky

▲ cena za kus

H5G-Z





80 907 ...

D ₁	mm	EUR	Y4
19		1,20	501

Základná doska pre predĺženie

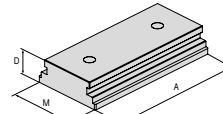
H5G





80 898 ...

A	mm	EUR	Y4
250		644,00	725

Upínacia páka

▲ vr. príslušenstva

NCG

NCG 5A

H5G



80 890 ...

DRVS	mm	EUR	Y4
14		128,00	501

Poistný kolík

H5G

H5G-S

H5G-Z

H5G-Z-S

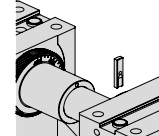



80 898 ...

EUR	Y4
12,40	024

Upínacia páka s kĺbom

▲ bez orecha

H5G-Z

H5G-Z-S

ESG 4

ESG mini

ZSG 4



80 891 ...

Štvorhran	1/2"	EUR	Y4
		76,10	600

Ručná kľuka

▲ pre rýchle nastavenie



H5G-Z	H5G-S	H5G
X5G-Z	H5G-Z-S	
80 907 ...	80 898 ...	80 898 ...
EUR	EUR	EUR
Y4	Y4	Y4
81,00	81,00	81,00
500	026	025

Orech

▲ vhodný pre štvorhran 1/2" alebo 3/8"

H5G-Z

ESG mini

MSG 2

Verso

MNG



80 877 ...

Štvorhran	DRVS	EUR	Y4
1/2"	mm	18,20	214

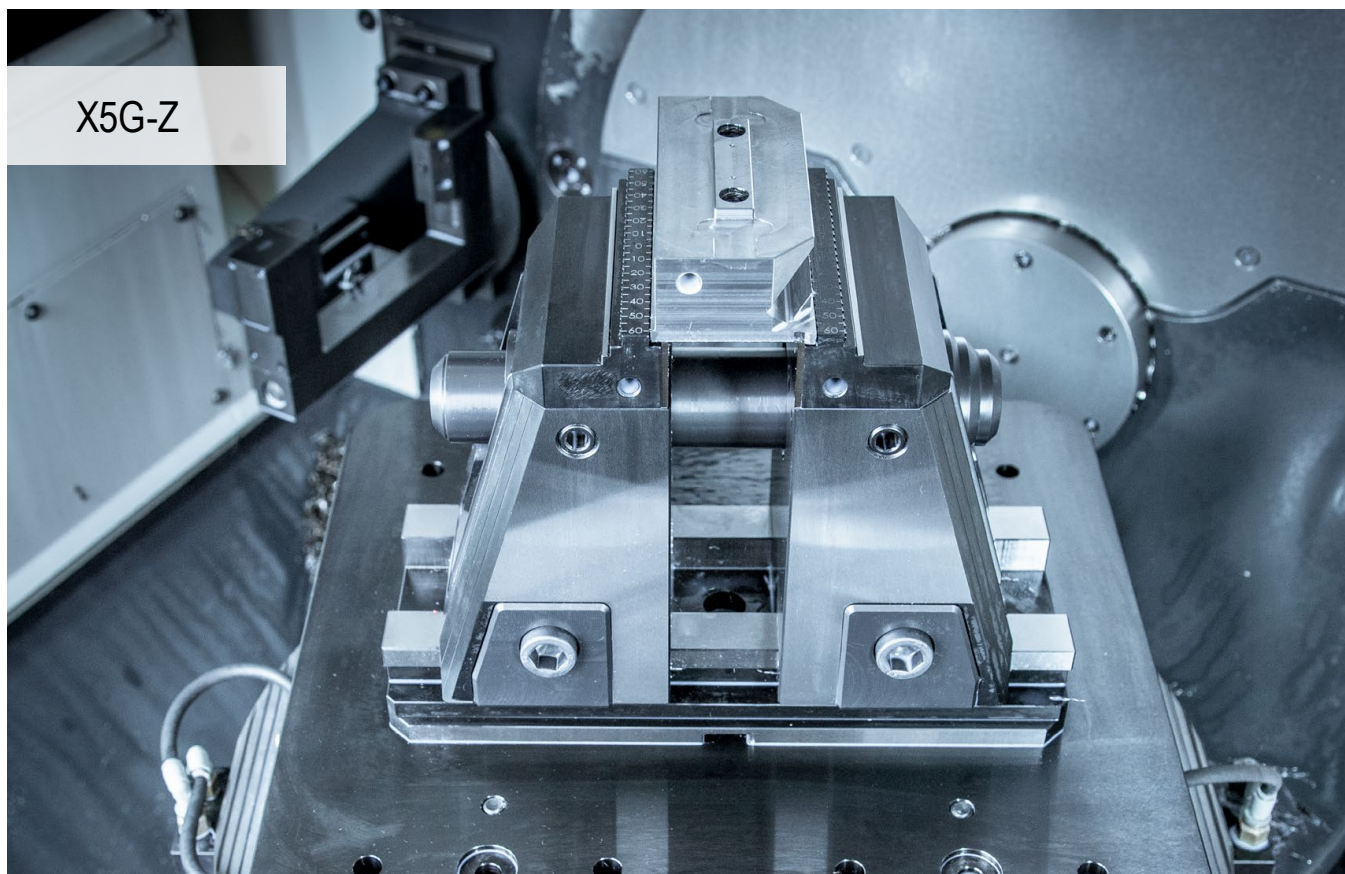

X5G-Z

Dokonalé 5osové obrábanie

Mimoriadne jednoduchá manipulácia a efekt vŕiahnutí obrabku dolu do čelustí pre šesťstranné obrábanie. X5G-Z je nový 5osový zverák od spoločnosti CERATIZIT. Všetky výhody optimálneho a jednoduchého päťstranného a šesťstranného obrábania v jednom jedinom upínači.

Výhody pre Vás:

- ▲ voliteľné päťstranné a šesťstranné obrábanie upnutím jednej alebo oboch upínacích čelustí
- ▲ rýchla výmena čelustí bez použitia náradia
- ▲ optimálna prístupnosť zo všetkých strán a veľký základný upínací zdvih, ktorý činí 130 mm
- ▲ celkom zapuzdrené, mechanické vreteno
- ▲ integrované tlenie pomocou elastomeru pre minimalizáciu vibrácií
- ▲ široká paleta čelustí a príslušenstva



Upnutie / Vyrovnávanie:



Upínanie pomocou dvoch lícovaných skrutiek $\text{\O} 12_{\text{T}} / \text{M12}$ Artikel č. 80 865 019 a upínacích skrutiek M12



Vyrovnávanie do T drážok stola pomocou kameňov lícovaných do drážok š. 20^{H7} v základnom telese. Upnutie pomocou úpiniek.



Vyrovnávanie a upnutie pomocou upínacieho systému s nulovým bodom MNG (2-3 upínacie čapy).
Variant: Polohovacie a upínacie otvory na želanie zákazníka.

Upínacia sila:

Konštrukčná veľkosť	Max. ťahovací moment v Nm	Max. upínacia sila v kN
X5G-Z Upínanie polotovarov	100	50
X5G-Z Precízne upínanie	120	40
X5G-Z-S Upínanie polotovarov	100	50
X5G-Z-S Precízne upínanie	120	34

Ťahovací moment / upínacia sila X5G-Z

Upínanie polotovarov

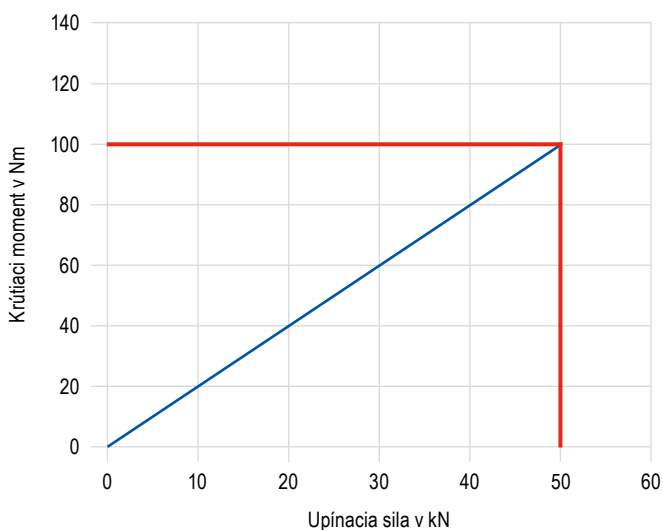

Precízne upínanie

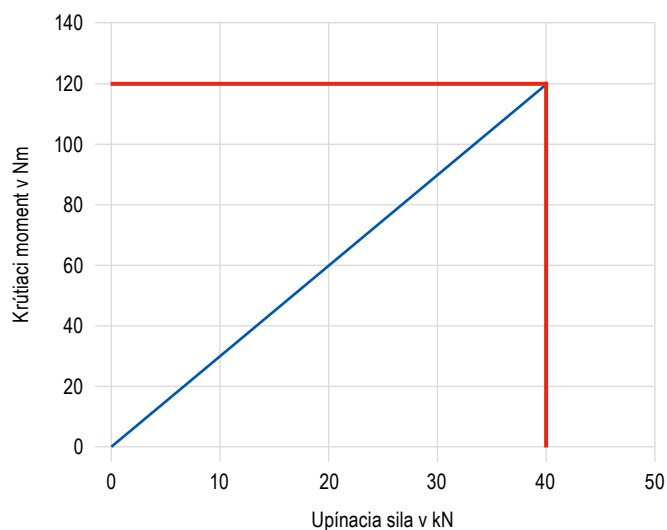

Ťahovací moment / upínacia sila X5G-Z-S

Upínanie polotovarov

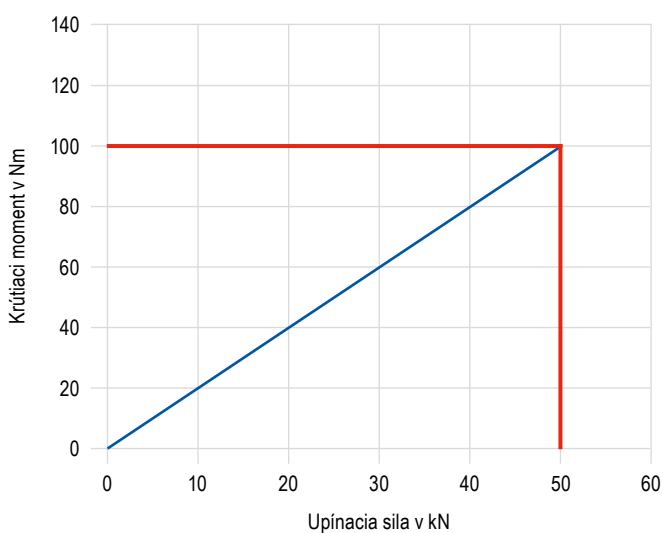

Precízne upínanie

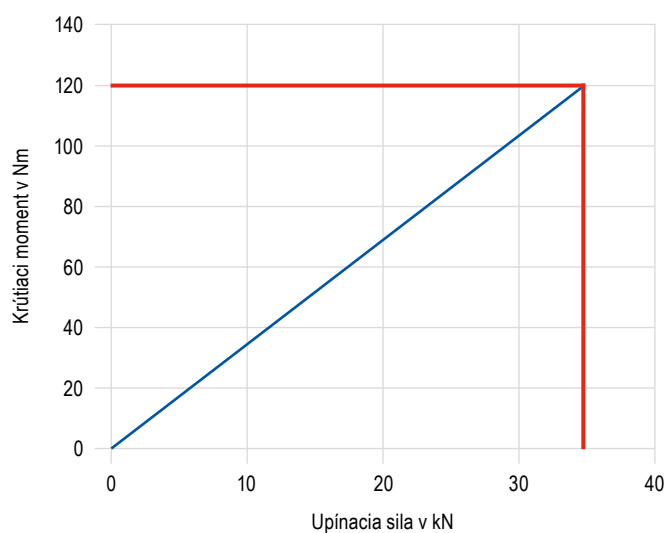

SoloClamp – X5G-Z

- ▲ mechanický 5 osový zverák s mobilnými pevnými čelustami, upínacia výška 181 mm
- ▲ bez systémových čelustí
- ▲ optimálna prístupnosť
- ▲ je možné vykonávať päťstranné a šesťstranné obrábanie
- ▲ rýchla výmena čelustí
- ▲ upínanie na stole je možné robiť pomocou čapov MNG/PNG alebo priamo cez základné teleso

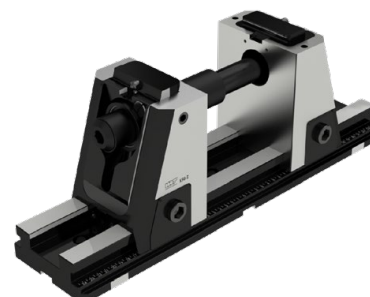
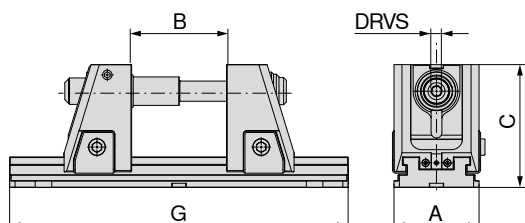
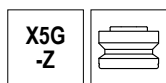

A	B	C	G	DRVS	MXC	WT	80 908 ...	
mm	mm	mm	mm	mm	kN	kg	EUR	Y4
125	4 - 134	181	330	14	40	33,2	3.170,00	52500
125	4 - 234	181	430	14	40	36,1	3.400,00	52600
125	4 - 304	181	500	14	40	38,1	3.540,00	52700
125	4 - 434	181	630	14	40	41,8	3.800,00	52800
125	4 - 604	181	800	14	40	46,6	4.140,00	52900

Základní upínací rozsah je 130 mm

→ **Strana 48**
Pre maximálny upínací rozsah je nutné použiť prídavné predĺženie tiaha.

→ **Strana 42–44**
Tabuľky konštrukčných rozmerov zveráka pri použití rôznych upínacích čelustí.

Prehľad zverákov

Rozmery spodnej strany	41	Systémové príslušenstvo	45
Upínací systém s nulovým bodom MNG/PNG	134–163	Obecné príslušenstvo	164–183

SoloClamp – X5G-Z-S

- ▲ mechanický 5 osový zverák s mobilnými pevnými čelustami, upínacia výška 142 mm
- ▲ bez systémových čelustí
- ▲ optimálna prístupnosť
- ▲ je možné vykonávať päťstranné a šesťstranné obrábanie
- ▲ rýchla výmena čelustí
- ▲ upínanie na stole je možné robiť pomocou čapov MNG/PNG alebo priamo cez základné teleso

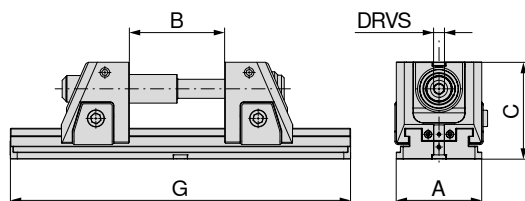

A	B	C	G	DRVS	MXC	WT	80 908 ...	
mm	mm	mm	mm	mm	kN	kg	EUR	
125	4 - 134	142	330	14	40	27,3	2.880,00	42500
125	4 - 234	142	430	14	40	30,2	3.110,00	42600
125	4 - 304	142	500	14	40	32,2	3.250,00	42700
125	4 - 434	142	630	14	40	35,9	3.510,00	42800
125	4 - 604	142	800	14	40	40,7	3.860,00	42900

 Základní upínací rozsah je 130 mm

 → **Strana 48**
Pre maximálny upínací rozsah je nutné použiť prídavné predĺženie tiahla.

 → **Strana 42–44**
Tabuľky konštrukčných rozmerov zveráka pri použití rôznych upínacích čelustí.

Prehľad zverákov

Rozmery spodnej strany	41	Systémové príslušenstvo	45
Upínací systém s nulovým bodom MNG/PNG	134–163	Obecné príslušenstvo	164–183

Rozmery spodnej strany X5G-ZI-S

Šírka základného telesa 125 mm,
dĺžka 330 mm

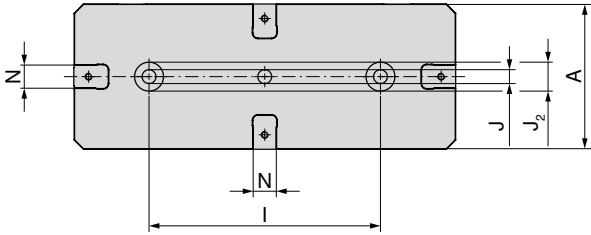

A	I _{±0,02}	J _{H7}	J _{2 H6}	N _{H7}
mm	mm	mm	mm	mm
125	200	12	25	20

Šírka základného telesa 125 mm,
dĺžka 630 mm

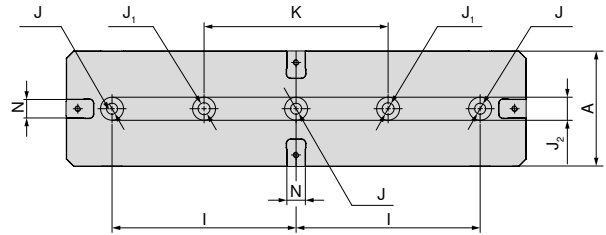

A	I _{±0,02}	J _{H7}	J ₁	J _{2 H6}	K _{±0,02}	N _{H7}
mm	mm	mm	mm	mm	mm	mm
125	200	12	13	25	200	20

Šírka základného telesa 125 mm,
dĺžka 430 mm

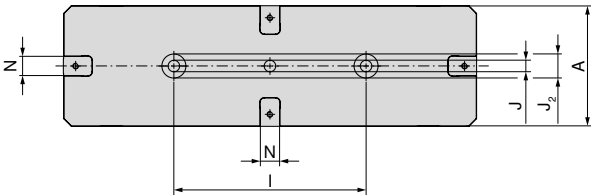

A	I _{±0,02}	J _{H7}	J _{2 H6}	N _{H7}
mm	mm	mm	mm	mm
125	200	12	25	20

Šírka základného telesa 125 mm,
dĺžka 800 mm

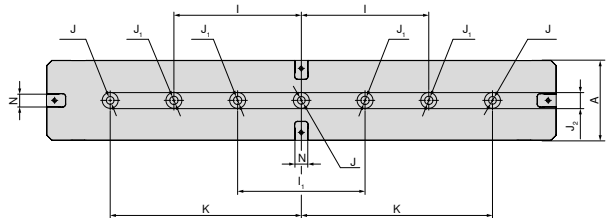

A	I _{±0,02}	I _{1 ±0,02}	J _{H7}	J ₁	J _{2 H6}	K _{±0,02}	N _{H7}
mm	mm	mm	mm	mm	mm	mm	mm
125	200	200	12	13	25	300	20

Šírka základného telesa 125 mm,
dĺžka 500 mm

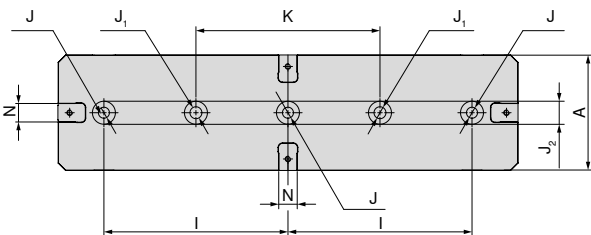

A	I _{±0,02}	J _{H7}	J ₁	J _{2 H6}
mm	mm	mm	mm	mm
125	200	12	13	25

X5G-Z/-S – Rozmerová tabuľka pre rôzne čeluste

S otočnými čelustami, grip 3 mm

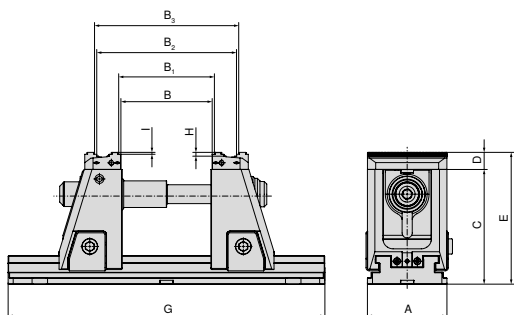

Typ	Predĺženie tiaha 430 mm 80 908 80000	Predĺženie tiaha 500 mm 80 908 80100	Predĺženie tiaha 630 mm 80 908 80200	Predĺženie tiaha 800 mm 80 908 80300	A	B	B ₁	B ₂	B ₃	C	D	E	G	H	I
80 908 52500					125	5-134	12-141	80-210	88-217	181	27	208	330	6	3
80 908 42500					125	5-134	12-141	80-210	88-217	142	27	169	330	6	3
80 908 52600	1 x				125	5-234	12-241	80-310	88-317	181	27	208	430	6	3
80 908 42600	1 x				125	5-234	12-241	80-310	88-317	142	27	169	430	6	3
80 908 52700	1 x	1 x			125	5-304	12-311	80-380	88-387	181	27	208	500	6	3
80 908 42700	1 x	1 x			125	5-304	12-311	80-380	88-387	142	27	169	500	6	3
80 908 52800	1 x	1 x	1 x		125	5-434	12-441	80-510	88-517	181	27	208	630	6	3
80 908 42800	1 x	1 x	1 x		125	5-434	12-441	80-510	88-517	142	27	169	630	6	3
80 908 52900	1 x	1 x	1 x	1 x	125	5-604	12-611	80-680	88-687	181	27	208	800	6	3
80 908 42900	1 x	1 x	1 x	1 x	125	5-604	12-611	80-680	88-687	142	27	169	800	6	3

S otočnými čelustami, grip 5 mm

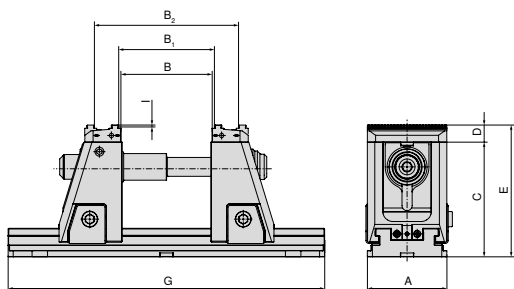

Typ	Predĺženie tiaha 430 mm 80 908 80000	Predĺženie tiaha 500 mm 80 908 80100	Predĺženie tiaha 630 mm 80 908 80200	Predĺženie tiaha 800 mm 80 908 80300	A	B	B ₁	B ₂	C	D	E	G	I
80 908 52500					125	5-134	12-141	88-217	181	27	208	330	5
80 908 42500					125	5-134	12-141	88-217	142	27	169	330	5
80 908 52600	1 x				125	5-234	12-241	88-317	181	27	208	430	5
80 908 42600	1 x				125	5-234	12-241	88-317	142	27	169	430	5
80 908 52700	1 x	1 x			125	5-304	12-311	88-387	181	27	208	500	5
80 908 42700	1 x	1 x			125	5-304	12-311	88-387	142	27	169	500	5
80 908 52800	1 x	1 x	1 x		125	5-434	12-441	88-517	181	27	208	630	5
80 908 42800	1 x	1 x	1 x		125	5-434	12-441	88-517	142	27	169	630	5
80 908 52900	1 x	1 x	1 x	1 x	125	5-604	12-611	88-687	181	27	208	800	5
80 908 42900	1 x	1 x	1 x	1 x	125	5-604	12-611	88-687	142	27	169	800	5



→ Strana 48

Prehľad systémového príslušenstva vrátane predĺženia tiaha.

X5G-Z/-S – Rozmerová tabuľka pre rôzne čeluste

So stupňovitou čelustou, karbid grip 5 mm

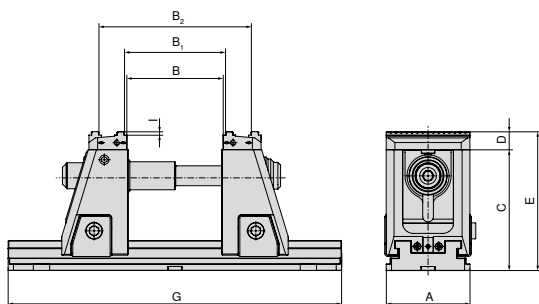

Typ	Predĺženie tiaha 430 mm 80 908 80000	Predĺženie tiaha 500 mm 80 908 80100	Predĺženie tiaha 630 mm 80 908 80200	Predĺženie tiaha 800 mm 80 908 80300	A	B	B ₁	B ₂	C	D	E	G	I
80 908 52500					125	5-134	12-141	88-217	181	27	208	330	5
80 908 42500					125	5-134	12-141	88-217	142	27	169	330	5
80 908 52600	1 x				125	5-234	12-241	88-317	181	27	208	430	5
80 908 42600	1 x				125	5-234	12-241	88-317	142	27	169	430	5
80 908 52700	1 x	1 x			125	5-304	12-311	88-387	181	27	208	500	5
80 908 42700	1 x	1 x			125	5-304	12-311	88-387	142	27	169	500	5
80 908 52800	1 x	1 x	1 x		125	5-434	12-441	88-517	181	27	208	630	5
80 908 42800	1 x	1 x	1 x		125	5-434	12-441	88-517	142	27	169	630	5
80 908 52900	1 x	1 x	1 x	1 x	125	5-604	12-611	88-687	181	27	208	800	5
80 908 42900	1 x	1 x	1 x	1 x	125	5-604	12-611	88-687	142	27	169	800	5

S mäkkými čelustami, ocel'

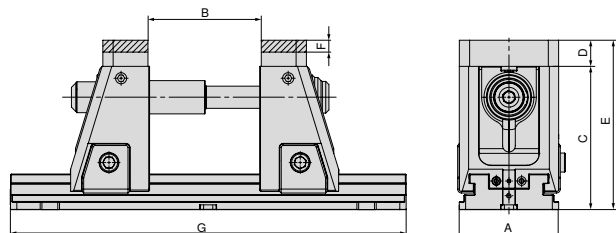
Artikel č.
Systémové čeluste

2 x 80 909 31200

Typ	Predĺženie tiaha 430 mm 80 908 80000	Predĺženie tiaha 500 mm 80 908 80100	Predĺženie tiaha 630 mm 80 908 80200	Predĺženie tiaha 800 mm 80 908 80300	A	B	C	D	E	F	G
80 908 52500					125	4-134	181	33	214	15	330
80 908 42500					125	4-134	142	33	175	15	330
80 908 52600	1 x				125	4-234	181	33	214	15	430
80 908 42600	1 x				125	4-234	142	33	175	15	430
80 908 52700	1 x	1 x			125	4-304	181	33	214	15	500
80 908 42700	1 x	1 x			125	4-304	142	33	175	15	500
80 908 52800	1 x	1 x	1 x		125	4-434	181	33	214	15	630
80 908 42800	1 x	1 x	1 x		125	4-434	142	33	175	15	630
80 908 52900	1 x	1 x	1 x	1 x	125	4-604	181	33	214	15	800
80 908 42900	1 x	1 x	1 x	1 x	125	4-604	142	33	175	15	800



→ Strana 48

Prehľad systémového príslušenstva vrátane predĺženia tiaha.

X5G-Z/-S – Rozmerová tabuľka pre rôzne čeluste

S otočnými čelustami grip so stupnicou

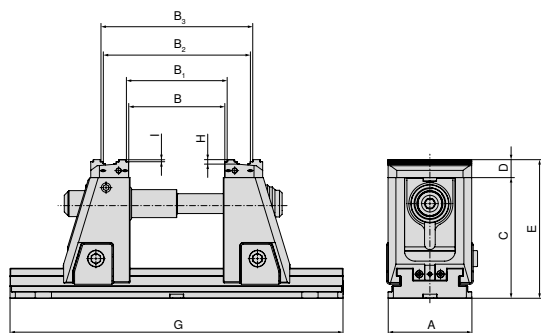
 Artikel č.
Systémové čeluste

2 x 80 908 31200

Typ	Predĺženie tiaha 430 mm 80 908 80000	Predĺženie tiaha 500 mm 80 908 80100	Predĺženie tiaha 630 mm 80 908 80200	Predĺženie tiaha 800 mm 80 908 80300	A	B	B ₁	B ₂	B ₃	C	D	E	G	H	I
80 908 52500					125	5-134	12-141	82-210	89-217	181	27	208	330	6	3
80 908 42500					125	5-134	12-141	82-210	89-217	142	27	169	330	6	3
80 908 52600	1 x				125	5-234	12-241	82-310	89-317	181	27	208	430	6	3
80 908 42600	1 x				125	5-234	12-241	82-310	89-317	142	27	169	430	6	3
80 908 52700	1 x	1 x			125	5-304	12-311	82-380	89-387	181	27	208	500	6	3
80 908 42700	1 x	1 x			125	5-304	12-311	82-380	89-387	142	27	169	500	6	3
80 908 52800	1 x	1 x	1 x		125	5-434	12-441	82-510	89-517	181	27	208	630	6	3
80 908 42800	1 x	1 x	1 x		125	5-434	12-441	82-510	89-517	142	27	169	630	6	3
80 908 52900	1 x	1 x	1 x	1 x	125	5-604	12-611	82-680	89-687	181	27	208	800	6	3
80 908 42900	1 x	1 x	1 x	1 x	125	5-604	12-611	82-680	89-687	142	27	169	800	6	3

S výkyvnou a adaptérovou čelustou

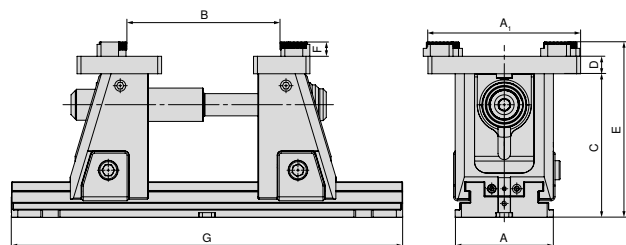
 Artikel č.
Systémové čeluste

80 909 31500 + 80 909 31300

Typ	Predĺženie tiaha 430 mm 80 908 80000	Predĺženie tiaha 500 mm 80 908 80100	Predĺženie tiaha 630 mm 80 908 80200	Predĺženie tiaha 800 mm 80 908 80300	A	B	C	D	E	F	G
80 908 52500					125	42-210	181	22	221	18	330
80 908 42500					125	42-210	142	22	182	18	330
80 908 52600	1 x				125	42-310	181	22	221	18	430
80 908 42600	1 x				125	42-310	142	22	182	18	430
80 908 52700	1 x	1 x			125	42-380	181	22	221	18	500
80 908 42700	1 x	1 x			125	42-380	142	22	182	18	500
80 908 52800	1 x	1 x	1 x		125	42-510	181	22	221	18	630
80 908 42800	1 x	1 x	1 x		125	42-510	142	22	182	18	630
80 908 52900	1 x	1 x	1 x	1 x	125	42-680	181	22	221	18	800
80 908 42900	1 x	1 x	1 x	1 x	125	42-680	142	22	182	18	800



→ Strana 48

Prehľad systémového príslušenstva vrátane predĺženia tiaha.

Prehľad systémových čelustí

Otočná čelusť, grip 3 mm

▲ cena za kus

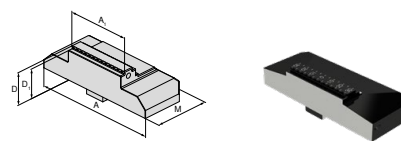

pre šírku zveráka	A	A ₁	D	D ₁	D ₂	E	M	M ₁	M ₂	EUR	Y4	NCG	H5G / -S / -Z	X5G-Z / -S	ESG 4	ESG 5	HDG 2	ZSG 4	ZSG mini	DSG 4	Veriso	HSG		
125	125	40	27	24			57			302,00	80 908 30300			●										
125	125	65	27	24			57			314,00	80 908 30200			●										
125	125	80	27	24			57			314,00	80 908 30100			●										
125	125	125	27	24			57			324,00	80 908 30000			●										

Otočná čelusť, grip 5 mm

▲ cena za kus

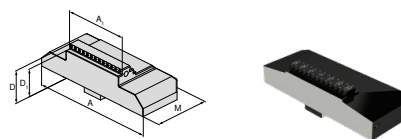

pre šírku zveráka	A	A ₁	D	D ₁	D ₂	E	M	M ₁	M ₂	EUR	Y4	NCG	H5G / -S / -Z	X5G-Z / -S	ESG 4	ESG 5	HDG 2	ZSG 4	ZSG mini	DSG 4	Veriso	HSG		
125	125	40	27	22			57			302,00	80 908 30700			●										
125	125	65	27	22			57			314,00	80 908 30600			●										
125	125	80	27	22			57			314,00	80 908 30500			●										
125	125	125	27	22			57			324,00	80 908 30400			●										

Otočná čelusť, hladká

▲ cena za kus

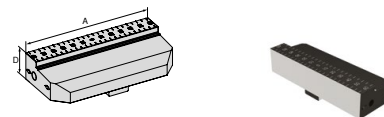

pre šírku zveráka	A	A ₁	D	D ₁	D ₂	E	M	M ₁	M ₂	EUR	Y4	NCG	H5G / -S / -Z	X5G-Z / -S	ESG 4	ESG 5	HDG 2	ZSG 4	ZSG mini	DSG 4	Veriso	HSG		
125	125		27							324,00	80 908 31400			●										

Stupňovitá čelusť, karbid grip 5 mm

▲ cena za kus

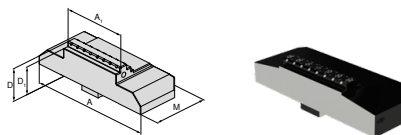

pre šírku zveráka	A	A ₁	D	D ₁	D ₂	E	M	M ₁	M ₂	EUR	Y4	NCG	H5G / -S / -Z	X5G-Z / -S	ESG 4	ESG 5	HDG 2	ZSG 4	ZSG mini	DSG 4	Veriso	HSG		
125	125	40	27	22			57			358,00	80 908 31100			●										
125	125	65	27	22			57			370,00	80 908 31000			●										
125	125	80	27	22			57			380,00	80 908 30900			●										
125	125	125	27	22			57			392,00	80 908 30800			●										

Prehľad systémových čelustí

Mäkké čeluste, oceľ

- ▲ materiál: 16MnCr5
- ▲ cena za kus

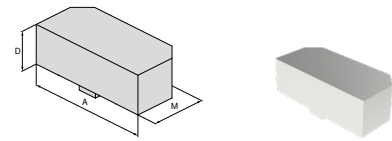

pre šírku zveráka	A	A ₁	D	D ₁	D ₂	E	M	M ₁	M ₂	EUR	Y4	NCG	H5G / -S / -Z	X5G-Z / -S	ESG 4	ESG 5	HDG 2	ZSG 4	ZSG mini	DSG 4	Verso	HSG	
125	125		33				57			140,00				●									

Otočná čelusť, grip so stupnicou

- ▲ zhodné s profilom LANG
- ▲ cena za kus

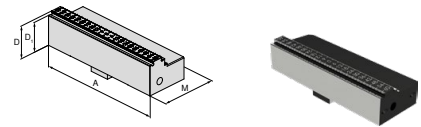

pre šírku zveráka	A	A ₁	D	D ₁	D ₂	E	M	M ₁	M ₂	EUR	Y4	NCG	H5G / -S / -Z	X5G-Z / -S	ESG 4	ESG 5	HDG 2	ZSG 4	ZSG mini	DSG 4	Verso	HSG	
125	125		27	24			57			324,00				●									

Adaptérová doska, pevná

- ▲ pre upínanie 6 násobných otočných čelustí
- ▲ vr. krycích skrutiek
- ▲ cena za kus

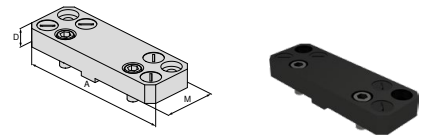

pre šírku zveráka	A	A ₁	D	D ₁	D ₂	E	M	M ₁	M ₂	EUR	Y4	NCG	H5G / -S / -Z	X5G-Z / -S	ESG 4	ESG 5	HDG 2	ZSG 4	ZSG mini	DSG 4	Verso	HSG	
125	180		22				104			414,00				●									

Výkyvná čelusť doska, pohyblivá

- ▲ pre upínanie 6 násobných otočných čelustí
- ▲ vr. krycích skrutiek
- ▲ cena za kus

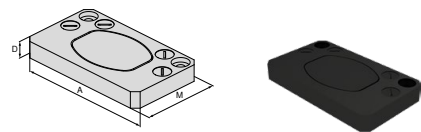

pre šírku zveráka	A	A ₁	D	D ₁	D ₂	E	M	M ₁	M ₂	EUR	Y4	NCG	H5G / -S / -Z	X5G-Z / -S	ESG 4	ESG 5	HDG 2	ZSG 4	ZSG mini	DSG 4	Verso	HSG	
125	180		22				62			553,00				●									

Prehľad systémových čelustí

Ľnasobná otočná čelusť

- ▲ 1 = hladká, s povlakom WC
- ▲ 2 = grip so stupňom 3 mm
- ▲ 3 = grip so stupňom 8 mm
- ▲ 4 = grip so stupňom 18 mm
- ▲ 5 = guľatý grip so stupňom 8 mm
- ▲ 6 = guľatý grip
- ▲ $M_{max} = 60 \text{ Nm}$
- ▲ vr. upínacej skrutky
- ▲ cena za kus

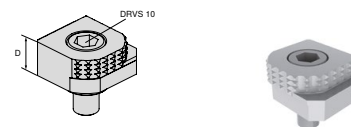

pre šírku zveráka	A	A ₁	D	D ₁	D ₂	E	M	M ₁	M ₂	EUR	Y4	NCG	H5G / -S / -Z	X5G-Z / -S	ESG 4	ESG 5	HDC 2	ZSG 4	ZSG mini	DSG 4	Verso	HSG
18										80,60	80 892 246	●	●	●	●			●		●	●	●

Ľnasobná otočná čelusť, karbid grip

- ▲ 1 = hladká
- ▲ 2 = karbidový grip
- ▲ 3 = karbidový grip so stupňom 3 mm
- ▲ 4 = karbidový grip so stupňom 8 mm
- ▲ 5 = karbidový guľatý grip so stupňom 8 mm
- ▲ 6 = karbidový guľatý grip
- ▲ vr. upínacej skrutky
- ▲ cena za kus

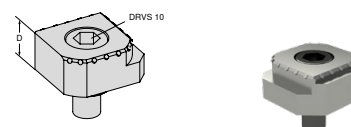

pre šírku zveráka	A	A ₁	D	D ₁	D ₂	E	M	M ₁	M ₂	EUR	Y4	NCG	H5G / -S / -Z	X5G-Z / -S	ESG 4	ESG 5	HDC 2	ZSG 4	ZSG mini	DSG 4	Verso	HSG
18										117,00	80 890 35300	●	●	●	●			●		●	●	●

Presná sada čelustí

- ▲ cena za súpravu

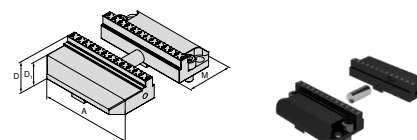

pre šírku zveráka	A	A ₁	D	D ₁	D ₂	E	M	M ₁	M ₂	EUR	Y4	NCG	H5G / -S / -Z	X5G-Z / -S	ESG 4	ESG 5	HDC 2	ZSG 4	ZSG mini	DSG 4	Verso	HSG	
125	125		27	24			57			490,00	80 908 31300			●									

Postup použitia pre kalenou sadu presných čelustí

X5G-Z presvedčí veľmi vysokou presnosťou, všetky súčasti sú brúsené alebo frézované za tvrda s vysokou presnosťou. Napriek tomu môžu existovať aplikácie, u ktorých nemusí byť úplne splnená požadovaná presnosť kvôli tolerančnému rezaci rýchlo výmenných čelustí. Pre tieto prípady ponúkame kalenú sadu presných čelustí (č. artiklu **80 908 31300**), ktorú si môže zákazník na upínacej ploche ofrézovať (z oboch strán).

Frézovanie kalených čelustí sa prevádza v presnom zveráku X5G-Z (obe skrutky na nosných čelustiach pritiahneme na 140 Nm). Čeluste musia byť vyfrézované podľa vyobrazených pohľadov (1+2). Dodaný referenčný kolík slúži k upnutiu v štandardnej polohe (1). Pre upnutie v rozšírenom rozsahu upnutia je možné použiť presnú podložku (2).

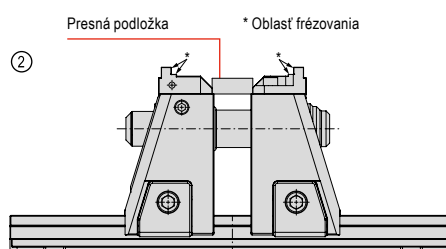
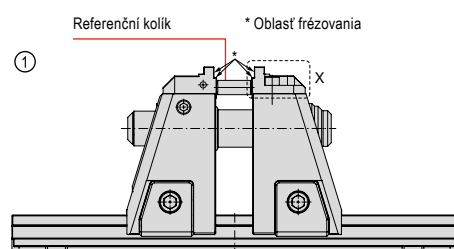

Prehľad systémového príslušenstva

Vreteno X5G-Z

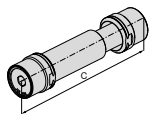

C mm	WT kg
227,5	2,5

80 908 ...

EUR
Y4
392,00 50100

Predĺženie tiaha

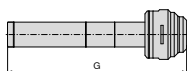

Pre šírku mm	G mm
125	430
125	500
125	630
125	800

80 908 ...

EUR
Y4
164,00 80000
177,00 80100
205,00 80200
235,00 80300

Momentový kľúč

▲ bez orecha



Štvorhran	TQX Nm
1/2"	10 - 100

80 884 ...

EUR
Y4
280,00 502

Ručná kľuka

- ▲ prevedenie s vonkajším šesťhranom
- ▲ pre rýchle nastavenie

H5G-Z
X5G-Z

80 907 ...

EUR
Y4
81,00 500

Pre šírku mm	DRVS mm
125	14

Orech



80 877 ...

EUR
Y4
18,20 214

Štvorhran	DRVS mm
1/2"	14

ESG 4

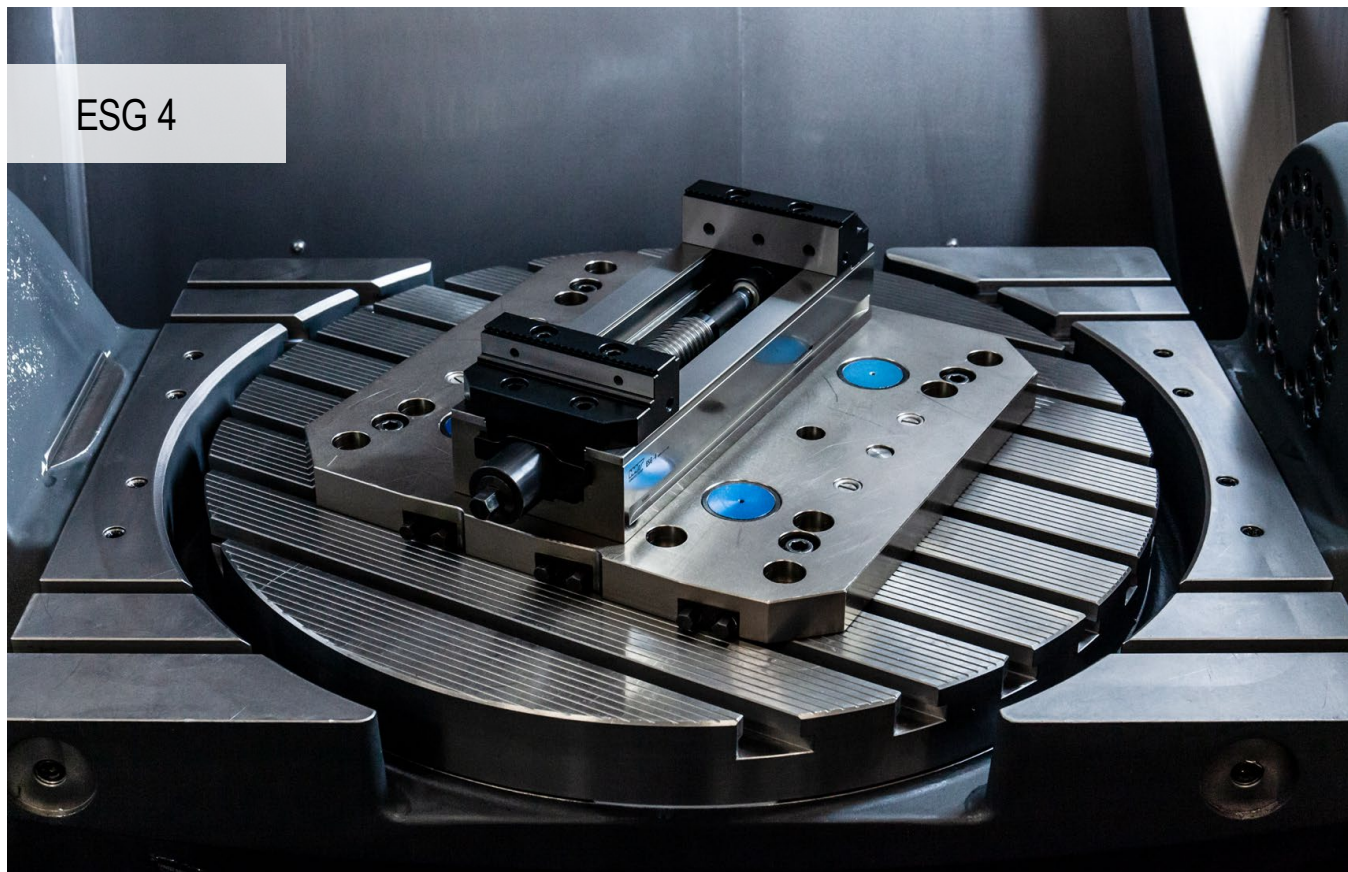

Vysoko efektívny univerzálny zverák pre obrábanie polotovarov i hotových dielov

Jednoduchý zverák ESG 4 si Vás získa svojím rýchlopúpaním pomocou páky, rýchlym nastavením upínacieho rozsahu, nižšou konštrukciou i malou hmotnosťou.

Výhody pre Vás:

- ▲ niekoľko drážok pre odvádzanie chladiaceho média pre nerušené obrábanie a kontrolované odvádzanie triesok
- ▲ jednoduché a rýchle polohovanie na upíname systéme s nulovým bodom MNG
- ▲ vysoké upínacie sily medzi 5 – 50 kN s nízkym ťahovacím momentom
- ▲ jednoduchá a rýchla výmena čeľustí pomocou 2 skrutiek
- ▲ rýchla a jednoduchá demontáž jednotky vretena
- ▲ široká paleta čeľustí – a príslušenstva

Upnutie / Vyrovnávanie:



ESG 4 – 80 mm = upínanie pomocou skrutiek M8 cez základné teleso
ESG 4 – 125 mm / 160 mm = upínanie pomocou skrutiek M12 a lícovaných skrutiek cez základné teleso



Upínanie pomocou 4 úpiniek Artikel č. 80 890 315



Upínanie pomocou upínacieho systému s nulovým bodom.
ESG 4 – 80 mm = 1 upínací čap + polohovací kolík
ESG 4 – 125 / 160 mm = 2 upínacie čapy, rozteč 200 mm

Upínacia sila:

Uťahovací moment / upínacia sila ESG 4 – 80 mm

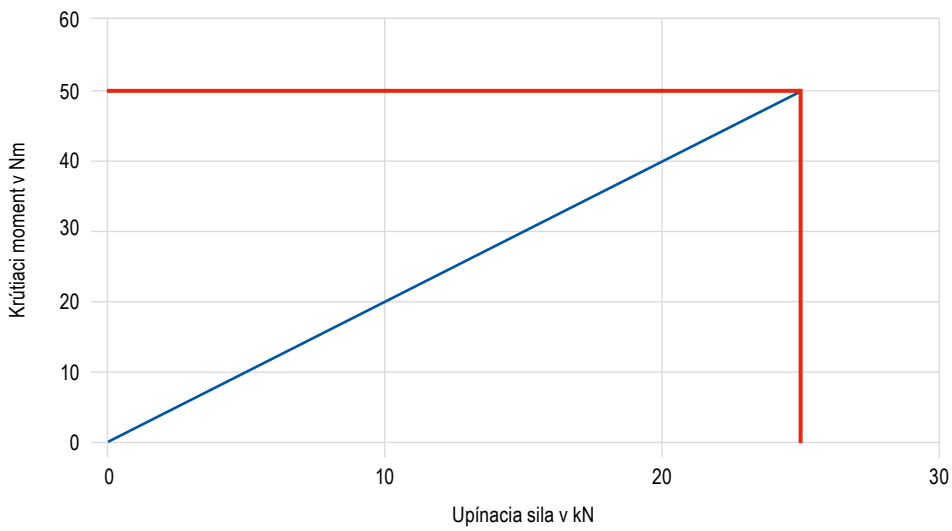

Uťahovací moment / upínacia sila ESG 4 – 125 mm

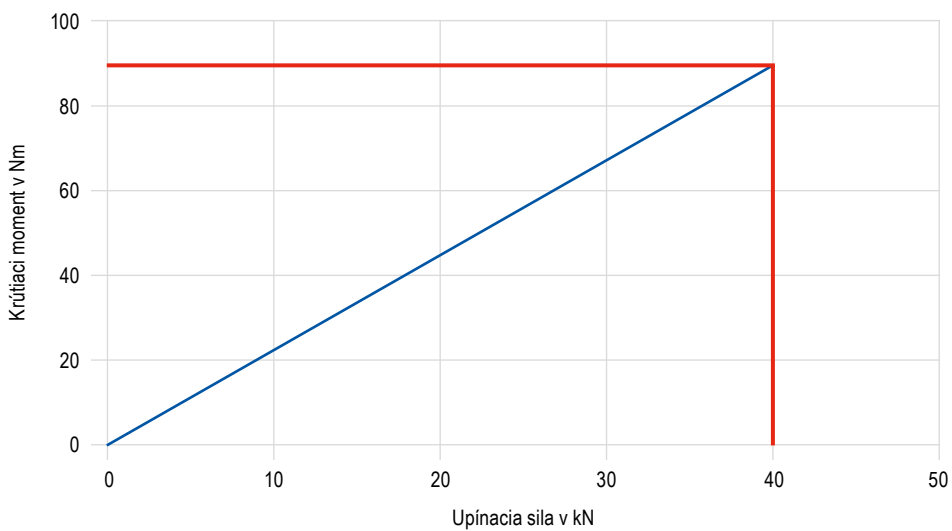

Uťahovací moment / upínacia sila ESG 4 – 160 mm

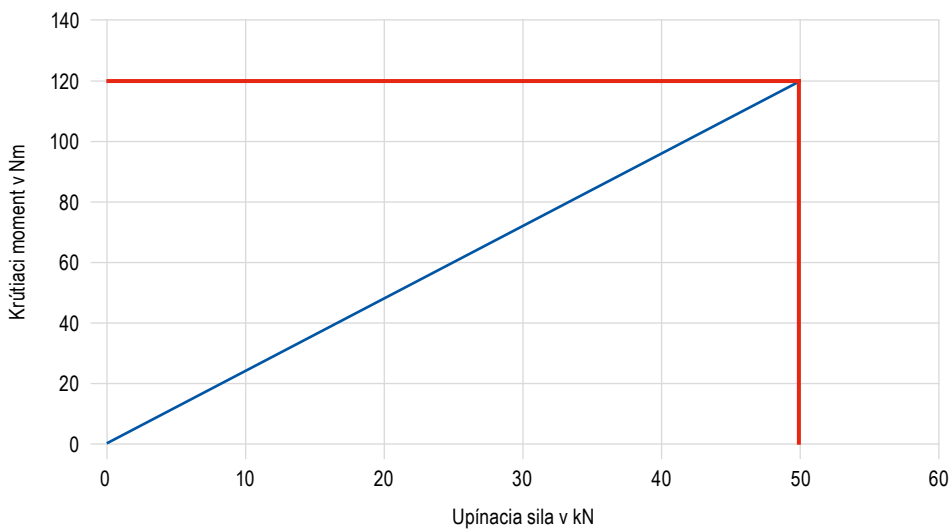

SoloClamp – ESG 4

- ▲ jednoduchý zverák bez systémových čelustí
- ▲ upínanie pomocou momentového kľúča
- ▲ rýchla montáž i demontáž jednotky vretena
- ▲ presnosť opakovania $\pm 0,01$ mm ($\pm 0,015$ mm v prípade A = 160 mm)

ESG
4

MNG

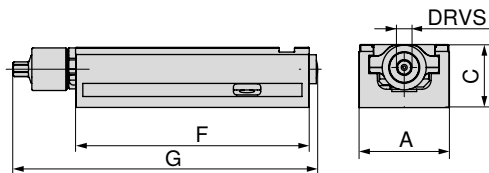

A	C _{-0.02}	F	G	DRVS	MXC	WT	Upínací rozsah	80 901 ...
mm	mm	mm	mm	mm	kN	kg	mm	EUR
80	55	214	284	12	25	5,0	0-192	Y4 1.230,00
125	60	362	433	14	40	15,0	0-308	080 1.520,00
160	70	480	559	14	50	28,5	0-434	125 2.220,00
								160

Prehľad zverákov

Rozmery spodnej strany	52	Rozmerové tabuľky pre rôzne čeluste	53+54
Systémové príslušenstvo	55–58	Upínací systém s nulovým bodom MNG/PNG	134–163
Obecné príslušenstvo	164–183		

Rozmery spodnej strany zveráka ESG 4

Šírka základného telesa 80 mm,
dĺžka 214 mm

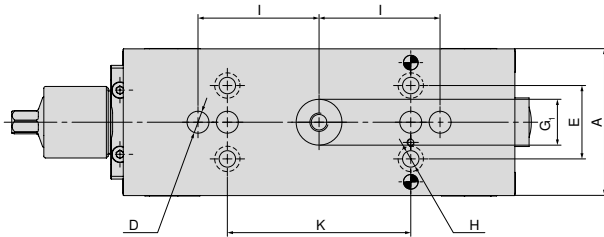

A	D	E	G ₁	H	I	K
mm	mm	mm	mm	mm	mm	mm
80	12	40	25	9	66	100

Šírka základného telesa 125 mm,
dĺžka 362 mm

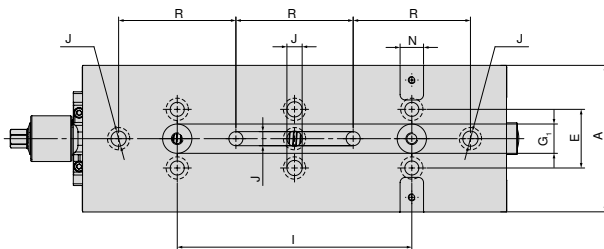

A	E	G ₁	I	J	N _{H7}	R
mm	mm	mm	mm	mm	mm	mm
125	50	25	200	13	20	100

Šírka základného telesa 160 mm,
dĺžka 480 mm

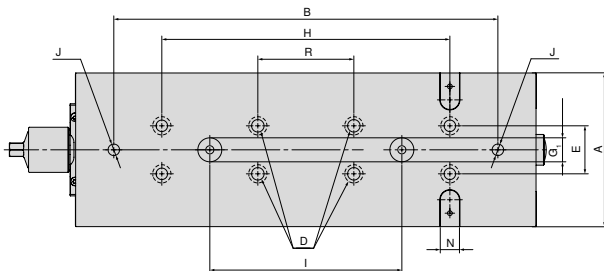

A	B	D	E	G ₁	H	I	J	N _{H7}	R
mm	mm	mm	mm	mm	mm	mm	mm	mm	mm
160	400	13	50	25	300	200	12	20	100

ESG 4 rozmerová tabuľka pre rôzne čeluste

S blokovými čelustami

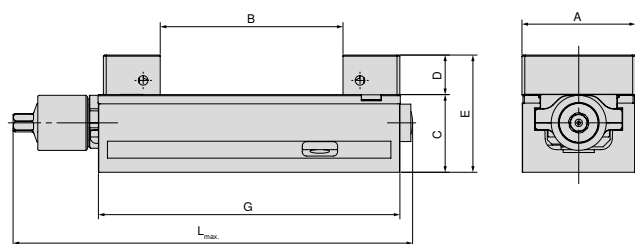

A mm	B mm	C mm	D mm	E mm	G mm	L _{max.} mm	Artikel č. Systémové čeluste		
80	0 - 130	55	28	83	214	308	80 901 31200	+	80 901 31300
125	0 - 231	60	40	100	362	432	80 901 31400	+	80 901 31500
160	0 - 312	70	50	120	480	559	80 901 31600	+	80 901 31700

S mäkkými hliníkovými čelustami

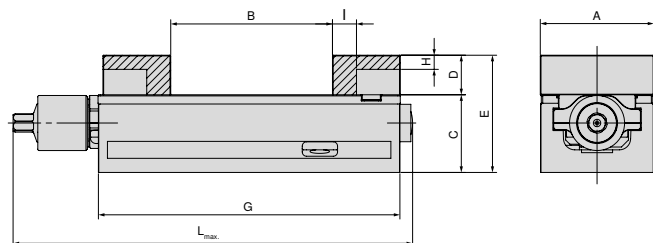

A mm	B mm	C mm	D mm	E mm	G mm	H mm	I mm	L _{max.} mm	Artikel č. Systémové čeluste	
80	0 - 115	55	28	83	214	10	17	284	80 901 307	+ 80 878 850
125	0 - 219	60	40	100	362	23	27	432	80 901 304	+ 80 878 550
160	0 - 309	70	50	120	480	23	30	559	80 901 301	+ 80 878 305

S výkyvnou a adaptérovou čelustou

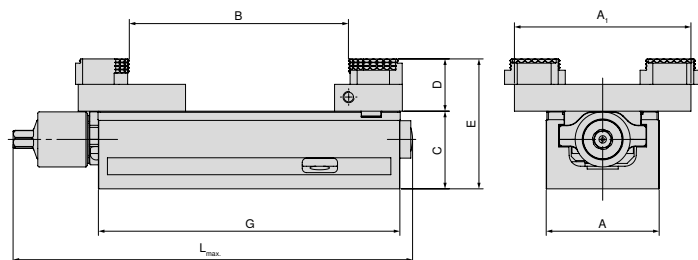

A mm	A ₁ mm	B mm	C mm	D mm	E mm	G mm	L _{max.} mm	Artikel č. Systémové čeluste		
80	125	5 - 155	55	19	92	214	284	80 878 870	+	80 901 501
125	180	4 - 306	60	22	100	362	432	80 878 570	+	80 901 502
160	256	11 - 463	70	22	110	480	559	80 878 670	+	80 901 503

ESG 4 rozmerová tabuľka pre rôzne čeluste

S otočnými čelustami, grip 3 mm

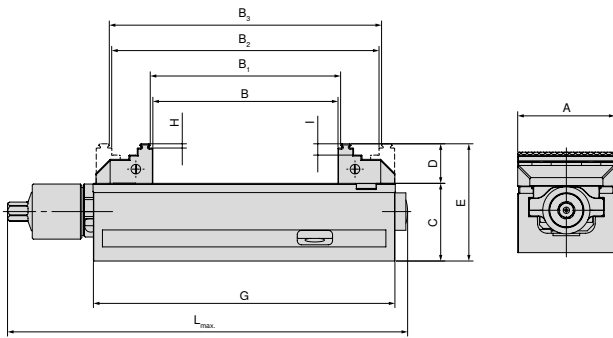

A mm	B mm	B ₁ mm	B ₂ mm	B ₃ mm	C mm	D mm	E mm	G mm	H mm	I mm	L _{max} mm	Artikel č. Systémové čeluste	
80	0 - 130	4 - 134	59 - 188	63 - 192	55	28	83	214	3	8	284	80 901 306	+ 80 878 810
125	0 - 231	8 - 238	71 - 301	78 - 308	60	40	100	362	3	18	433	80 901 302	+ 80 901 303
160	0 - 310	8 - 317	117 - 427	125 - 434	70	50	120	480	3	10	559	80 901 300	+ 80 878 610

S otočnými čelustami, grip 3 mm, šírka 40 mm

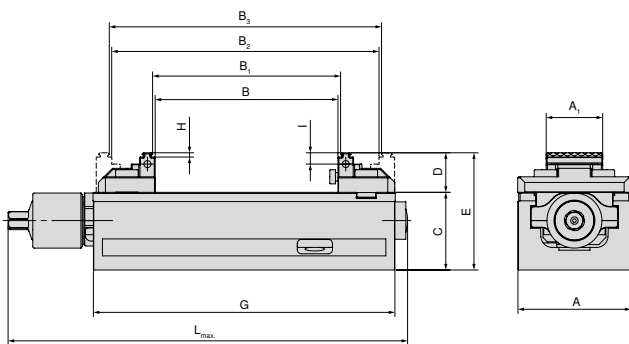

A mm	A ₁ mm	B mm	B ₁ mm	B ₂ mm	B ₃ mm	C mm	D mm	E mm	G mm	H mm	I mm	L _{max} mm	Artikel č. Systémové čeluste	
80	40	0 - 130	4 - 134	59 - 188	63 - 192	55	28	83	214	3	8	284	80 901 308	+ 80 878 81900

S otočnými čelustami, grip 3 mm, šírka 65 mm

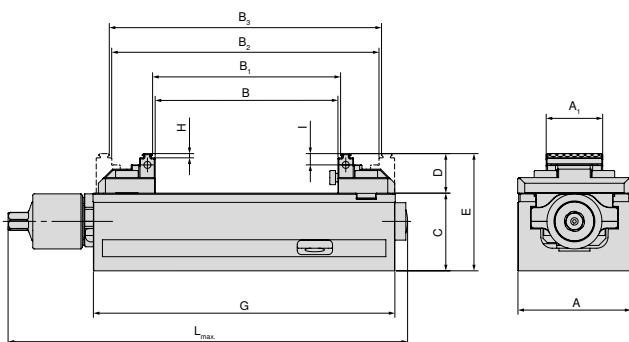

A mm	A ₁ mm	B mm	B ₁ mm	B ₂ mm	B ₃ mm	C mm	D mm	E mm	G mm	H mm	I mm	L _{max} mm	Artikel č. Systémové čeluste	
125	65	0 - 240	8 - 247	77 - 317	84 - 324	60	33	93	362	3	9	432	80 901 305	+ 80 878 51900

Prehľad systémových čelustí

Otočná čelusť, grip 3 mm, pevná

▲ cena za kus

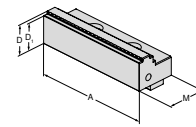

pre šírku zveráka	A	A ₁	D	D ₁	D ₂	E	M	M ₁	M ₂	EUR	Y4	NCG	H5G / -S / -Z	X5G-Z / -S	ESG 4	ESG 5	HDG 2	ZSG 4	ZSG mini	DSG 4	Verso	HSG	
80	80		28	25			40			163,00	80 901 306				●	●							
125	125		40	37			66			224,00	80 901 302				●	●					●		
160	160		50	47			81			404,00	80 901 300				●	●							

Otočná čelusť, grip 3 mm, pohyblivá

▲ cena za kus

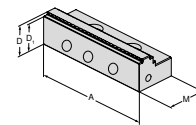

pre šírku zveráka	A	A ₁	D	D ₁	D ₂	E	M	M ₁	M ₂	EUR	Y4	NCG	H5G / -S / -Z	X5G-Z / -S	ESG 4	ESG 5	HDG 2	ZSG 4	ZSG mini	DSG 4	Verso	HSG	
80	80		28	25			40			135,00	80 878 810				●	●			●		●		
125	125		40	37			66			224,00	80 901 303				●	●				●			
160	160		50	47			81			404,00	80 878 610				●	●		●					

Bloková čelusť, pevná

▲ cena za kus

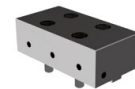
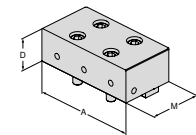

pre šírku zveráka	A	A ₁	D	D ₁	D ₂	E	M	M ₁	M ₂	EUR	Y4	NCG	H5G / -S / -Z	X5G-Z / -S	ESG 4	ESG 5	HDG 2	ZSG 4	ZSG mini	DSG 4	Verso	HSG	
80	80		28				40			251,00	80 901 31200				●	●							
125	125		40				66			349,00	80 901 31400				●	●							
160	160		50				81			441,00	80 901 31600				●	●							

Bloková čelusť, pohyblivá

▲ cena za kus

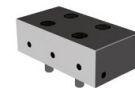
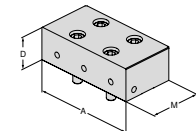

pre šírku zveráka	A	A ₁	D	D ₁	D ₂	E	M	M ₁	M ₂	EUR	Y4	NCG	H5G / -S / -Z	X5G-Z / -S	ESG 4	ESG 5	HDG 2	ZSG 4	ZSG mini	DSG 4	Verso	HSG	
80	80		28				40			244,00	80 901 31300				●	●		●		●			
125	125		40				66			342,00	80 901 31500				●	●				●			
160	160		50				81			430,00	80 901 31700				●	●		●					

Prehľad systémových čelustí

Hliníková čelusť, pevná

- ▲ pre výrobu tvarových čelustí
- ▲ cena za kus

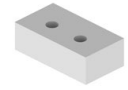
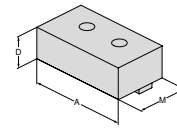

pre šírku zveráka	A	A ₁	D	D ₁	D ₂	E	M	M ₁	M ₂	EUR	Y4	NCG	H5G / -S / -Z	X5G-Z / -S	ESG 4	ESG 5	HDC 2	ZSG 4	ZSG mini	DSG 4	Verso	HSG	
80	80		28				48			101,00	80 901 307				●	●							
125	125		40				68			110,00	80 901 304				●	●							
160	160		50				85			124,00	80 901 301				●	●							

Hliníková čelusť, pohyblivá

- ▲ pre výrobu tvarových čelustí
- ▲ cena za kus

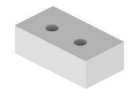
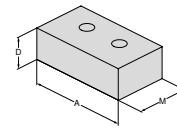

pre šírku zveráka	A	A ₁	D	D ₁	D ₂	E	M	M ₁	M ₂	EUR	Y4	NCG	H5G / -S / -Z	X5G-Z / -S	ESG 4	ESG 5	HDC 2	ZSG 4	ZSG mini	DSG 4	Verso	HSG	
80	80		28				48			86,40	80 878 850				●	●		●			●		
125	125		40				68			98,30	80 878 550				●	●					●		
160	160		50				85			124,00	80 878 305				●	●		●					

Mäkká čelusť, oceľ, pevná

- ▲ materiál: 16MnCr5
- ▲ pre výrobu tvarových čelustí
- ▲ cena za kus

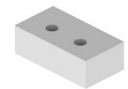
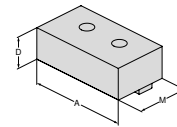

pre šírku zveráka	A	A ₁	D	D ₁	D ₂	E	M	M ₁	M ₂	EUR	Y4	NCG	H5G / -S / -Z	X5G-Z / -S	ESG 4	ESG 5	HDC 2	ZSG 4	ZSG mini	DSG 4	Verso	HSG	
80	80		28				48			104,00	80 901 31800				●	●							
125	125		40				68			125,00	80 901 31900				●	●							

Mäkká čelusť, oceľ, pohyblivá

- ▲ materiál: 16MnCr5
- ▲ pre výrobu tvarových čelustí
- ▲ cena za kus

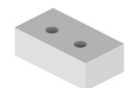
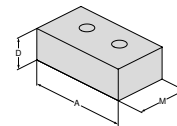

pre šírku zveráka	A	A ₁	D	D ₁	D ₂	E	M	M ₁	M ₂	EUR	Y4	NCG	H5G / -S / -Z	X5G-Z / -S	ESG 4	ESG 5	HDC 2	ZSG 4	ZSG mini	DSG 4	Verso	HSG	
80	80		28				48			89,10	80 878 32000				●	●		●					
125	125		40				68			112,00	80 878 32100				●	●		●					

Prehľad systémových čelustí

Otočná čelusť, grip 3 mm, šírka 40 mm, pevná

- ▲ dvostranný stupeň grip
- ▲ cena za kus

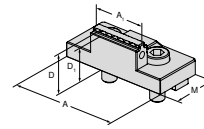

pre šírku zveráka	A	A ₁	D	D ₁	D ₂	E	M	M ₁	M ₂
80	80	40	28	25			40		

EUR

Y4

196,00

80 901 308

NCG	H5G / -S / -Z	X5G-Z / -S	ESG 4	ESG 5	HDG 2	ZSG 4	ZSG mini	DSG 4	Verso	HSG
			●							

Otočná čelusť, grip 3 mm, šírka 40 mm, pohyblivá

- ▲ cena za kus

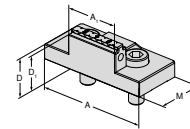

pre šírku zveráka	A	A ₁	D	D ₁	D ₂	E	M	M ₁	M ₂
80	80	40	28	25			40		

EUR

Y4

180,00

80 878 81900

NCG	H5G / -S / -Z	X5G-Z / -S	ESG 4	ESG 5	HDG 2	ZSG 4	ZSG mini	DSG 4	Verso	HSG
			●			●				

5osová otočná čelusť, grip 3 mm, šírka 65 mm, pevná

- ▲ dvostranný stupeň grip
- ▲ cena za kus

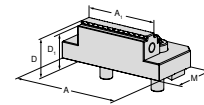

pre šírku zveráka	A	A ₁	D	D ₁	D ₂	E	M	M ₁	M ₂
125	95	65	33	30			57		

EUR

Y4

214,00

80 901 305

NCG	H5G / -S / -Z	X5G-Z / -S	ESG 4	ESG 5	HDG 2	ZSG 4	ZSG mini	DSG 4	Verso	HSG
			●							

5osová otočná čelusť, grip 3 mm, šírka 65 mm, pohyblivá

- ▲ dvostranný stupeň grip
- ▲ cena za kus

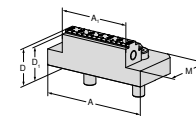

pre šírku zveráka	A	A ₁	D	D ₁	D ₂	E	M	M ₁	M ₂
125	95	65	33	30			57		

EUR

Y4

196,00

80 878 51900

NCG	H5G / -S / -Z	X5G-Z / -S	ESG 4	ESG 5	HDG 2	ZSG 4	ZSG mini	DSG 4	Verso	HSG
						●				

Prehľad systémových čelustí

Výkyvná doska, pohyblivá

- ▲ pre upínanie 6násobných otočných čelustí
- ▲ cena za kus
- ▲ vr. krycích skrutiek

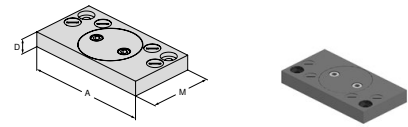

pre šírku zveráka	A	A ₁	D	D ₁	D ₂	E	M	M ₁	M ₂	EUR	Y4	NCG	H5G / -S / -Z	X5G-Z / -S	ESG 4	ESG 5	HDG 2	ZSG 4	ZSG mini	DSG 4	Verso	HSG	
80	125		19				76			409,00	80 878 870				●				●		●		
125	180		22				95			426,00	80 878 570				●				●		●		
160	256		22				170			726,00	80 878 670				●				●		●		

Adaptérová doska, pevná

- ▲ pre upínanie 6násobných otočných čelustí
- ▲ cena za kus
- ▲ vr. krycích skrutiek

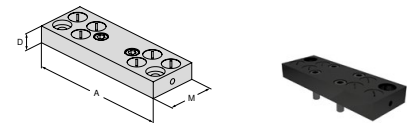

pre šírku zveráka	A	A ₁	D	D ₁	D ₂	E	M	M ₁	M ₂	EUR	Y4	NCG	H5G / -S / -Z	X5G-Z / -S	ESG 4	ESG 5	HDG 2	ZSG 4	ZSG mini	DSG 4	Verso	HSG	
80	125		19				48			291,00	80 901 501				●								
125	180		22				62			346,00	80 901 502				●								
160	256		22				125			484,00	80 901 503				●								

6násobná otočná čelusť

- ▲ 1 = hladká, s povlakom WC
- ▲ 2 = grip so stupňom 3 mm
- ▲ 3 = grip so stupňom 8 mm
- ▲ 4 = grip so stupňom 18 mm
- ▲ 5 = guľatý grip so stupňom 8 mm
- ▲ 6 = guľatý grip
- ▲ M_{max} = 60 Nm
- ▲ vr. upínacej skrutky
- ▲ cena za kus

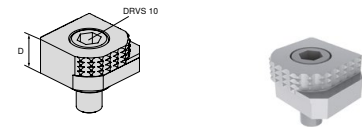

pre šírku zveráka	A	A ₁	D	D ₁	D ₂	E	M	M ₁	M ₂	EUR	Y4	NCG	H5G / -S / -Z	X5G-Z / -S	ESG 4	ESG 5	HDG 2	ZSG 4	ZSG mini	DSG 4	Verso	HSG	
			18							80,60	80 892 246	●	●	●	●				●		●	●	

6násobná otočná čelusť, karbid grip

- ▲ 1 = hladká
- ▲ 2 = karbidový grip
- ▲ 3 = karbidový grip so stupňom 3 mm
- ▲ 4 = karbidový grip so stupňom 8 mm
- ▲ 5 = karbidový guľatý grip so stupňom 8 mm
- ▲ 6 = karbidový guľatý grip
- ▲ vr. upínacej skrutky
- ▲ cena za kus

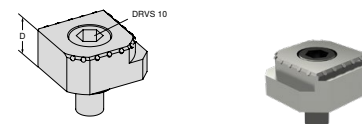

pre šírku zveráka	A	A ₁	D	D ₁	D ₂	E	M	M ₁	M ₂	EUR	Y4	NCG	H5G / -S / -Z	X5G-Z / -S	ESG 4	ESG 5	HDG 2	ZSG 4	ZSG mini	DSG 4	Verso	HSG	
			18							117,00	80 890 35300	●	●	●	●				●		●	●	

ESG 5

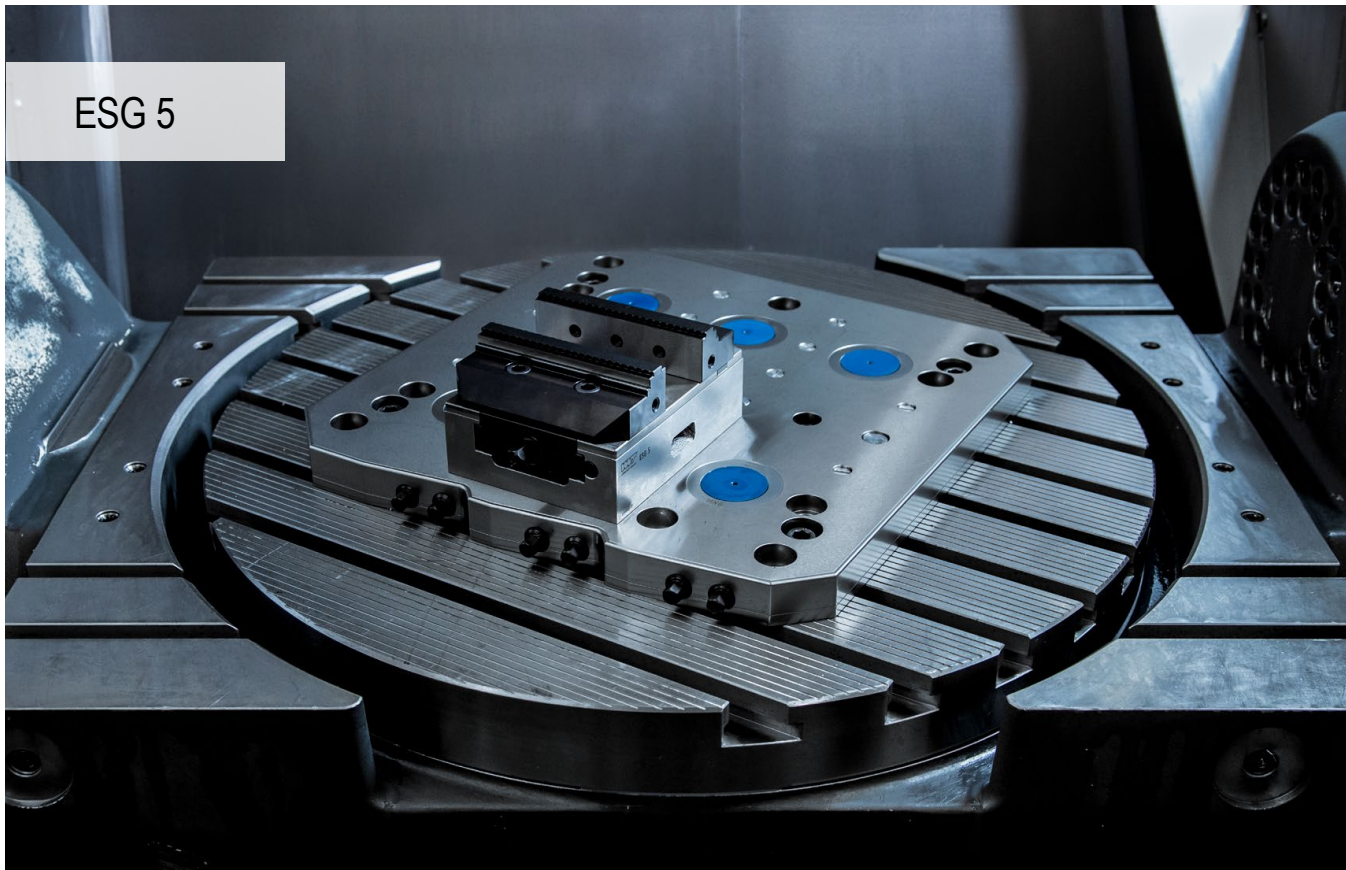

Optimalizovaný zverák ESG 5 – Maximálna precíznosť a procesná bezpečnosť

Nový zverák ESG 5 preberá všetky obľúbené vlastnosti svojho predchodcu a značne zdvíha latku v oblasti užívateľskej prívetivosti a životnosti. Prioritou pri optimalizácii jednoduchého zveráka bolo zabezpečenie lepšej manipulácie a dlhšej životnosti.

Výhody pre Vás:

- ▲ obzvlášť vhodné na obojstranné obrábanie vďaka vysokej uhlovej presnosti
- ▲ kompaktný design umožňuje optimálny prístup
- ▲ jednoduchá a rýchla výmena čelustí, pomocou dvoch skrutiek
- ▲ rovnaké upínacie rozsahy, oveľa lepší vonkajší obrys bez kolíznych prvkov, rozsiahla ponuka modulárnych čelustí
- ▲ odolný model s poniklovaným základným telesom garantuje dlhú životnosť

Upnutie / Vyrovnávanie:



Upínanie pomocou upínacieho systému s nulovým bodom.

ESG 5 – 80 mm L-130 mm + L-190 mm
ESG 5 – 125 mm L-160 mm + L-235 mm

1 upínací čap MNG + polohovací kolík



Upínanie pomocou upínacieho systému s nulovým bodom.

ESG 5 – 125 mm + L-300 mm
ESG 5 – 160 mm + L-280 mm + L-480 mm

2 upínacie čapy MNG



Vo všetkých variantoch sú vždy k dispozícii presné otvory $\varnothing 12^{JS}$, pomocou ktorých je možné zverák ESG 5 precízne polohovať. Všetky varianty je možné pripieňovať pomocou skrutiek zhora cez základné teleso.

Upnutie / Vyrovnávanie:



ESG 5 – 125 mm L-235 mm + L-300 mm
ESG 5 – 160 mm L-280 mm + L-480 mm

Tieto 4 varianty je možné alternatívne upínať i pomocou úpiniek.

Upínacia sila:

Uťahovací moment / upínacia sila ESG 5 – 80 mm

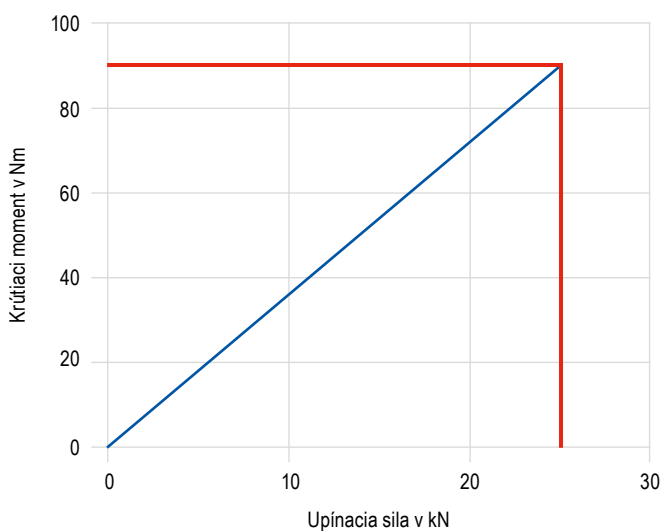

Uťahovací moment / upínacia sila ESG 5 – 125 mm

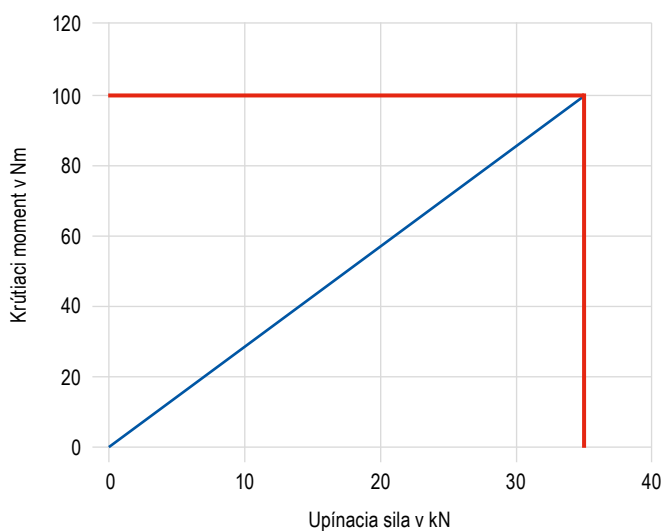

Uťahovací moment / upínacia sila ESG 5 – 160 mm

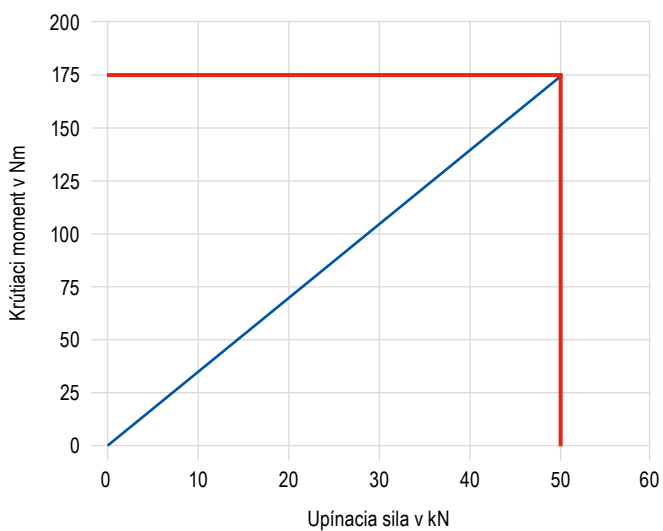

SoloClamp – ESG 5

- ▲ jednoduchý zverák bez systémových čelustí
- ▲ obzvlášť vhodné na obrábanie 2. strany obrobku vďaka vysokej uhlovej presnosti
- ▲ presnosť opakovania $\pm 0,01$ mm medzi dvomi upínacími operáciami
- ▲ vhodný pre PNG a MNG

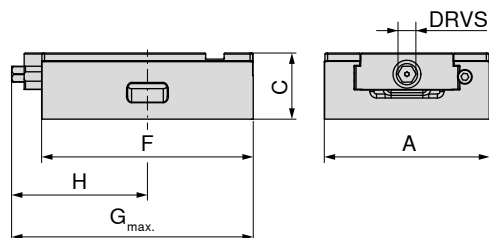
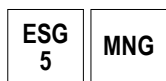

A	C _{±0.01}	F	G _{max.}	H	DRVS	MXC	WT	80 857 ...	
mm	mm	mm	mm	mm	mm	kN	kg	EUR	Y4
80	50	130	155,0	82	12	25	2,9	553,00	08500
80	50	190	203,0	102	12	25	4,4	665,00	08600
125	50	160	169,0	103	12	35	6,0	726,00	15000
125	50	235	235,0	132	12	35	8,4	927,00	15100
125	50	300	300,0	170	12	35	10,5	1.230,00	15200
160	70	280	309,0	169	14	50	25,0	1.710,00	26100
160	70	480	512,5	267	14	50	30,0	2.040,00	26200

Vhodný pre upínací systém s nulovým bodom							LANG Quick Point	
Artikel č.	Typ	Šírka v mm	Výška v mm	MNG	MNG mini	PNG	96 x 96	52 x 52
80 857 08500	ESG 5	80	130	✓	✓	✗	✗	✓
80 857 08600		80	190	✓	✗	✓	✗	✓
80 857 15000		125	160	✓	✗	✓	✓	✓
80 857 15100		125	235	✓	✗	✓	✓	✗
80 857 15200		125	300	✓	✗	✓	✓	✗
80 857 26100		160	280	✓	✗	✓	✓	✗
80 857 26200		160	480	✓	✗	✓	✗	✗

Prehľad zverákov

Rozmery spodnej strany	63+64	Rozmerové tabuľky pre rôzne čeluste	65
Systémové príslušenstvo	66	Upínací systém s nulovým bodom MNG/PNG	134–163
Obecné príslušenstvo	164–183		

SoloClamp – ESG 5

- ▲ zapuzdrený jednoduchý zverák pre Erowa ITS 148
- ▲ bez systémových čelustí
- ▲ obzvlášť vhodné na obrábanie 2. strany obrobku vďaka vysokej uhlovej presnosti
- ▲ presnosť opakovania $\pm 0,01$ mm medzi dvomi upínacími operáciami

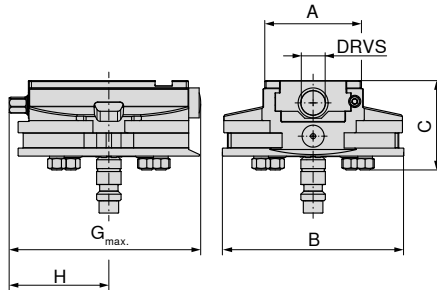
ESG
5

80 857 ...

EUR
Y4

1.370,00 08900

A	B	C	G _{max.}	H	DRVS	MXC	WT
mm	mm	mm	mm	mm	mm	kN	kg
80	148	73	157	81	12	25	5,6

Prehľad zverákov

Rozmery spodnej strany	63+64	Rozmerové tabuľky pre rôzne čeluste	65
Systémové príslušenstvo	66	Upínací systém s nulovým bodom MNG/PNG	134–163
Obecné príslušenstvo	164–183		

Rozmery spodnej strany zveráka ESG 5

Šírka základného telesa 80 mm,
dĺžka 130 mm

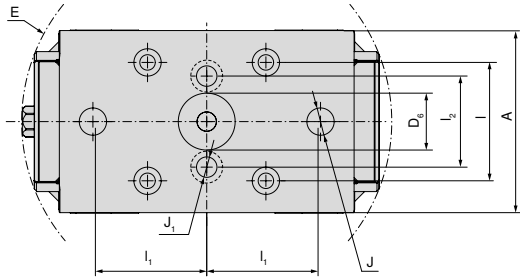

A	D ₆ H ₆	E	I ₁ ±0.015	I ₁ ±0.015	I ₂	J H ₇	J ₁
mm	mm	mm	mm	mm	mm	mm	mm
80	25	163	52	50	40	12	9

Šírka základného telesa 80 mm,
dĺžka 190 mm

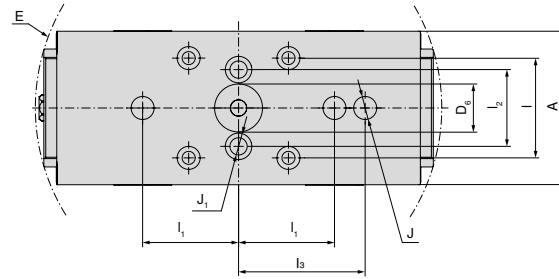

A	D ₆ H ₆	E	I ₁ ±0.015	I ₁ ±0.015	I ₂	I ₃ ±0.015	J H ₇	J ₁
mm	mm	mm	mm	mm	mm	mm	mm	mm
80	25	213	52	50	40	66	12	9

Šírka základného telesa 125 mm,
dĺžka 160 mm

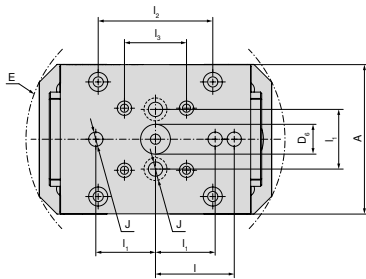

A	D ₆ H ₆	E	I ₁ ±0.015	I ₁ ±0.015	I ₂	I ₃ ±0.015	J H ₇
mm	mm	mm	mm	mm	mm	mm	mm
125	25	218	66	50	96	52	12

Šírka základného telesa 125 mm,
dĺžka 235 mm

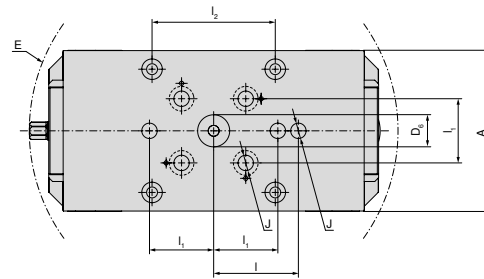

A	D ₆ H ₆	E	I ₁ ±0.015	I ₁ ±0.015	I ₂	J H ₇
mm	mm	mm	mm	mm	mm	mm
125	25	288	66	50	96	12

Šírka základného telesa 125 mm,
dĺžka 300 mm

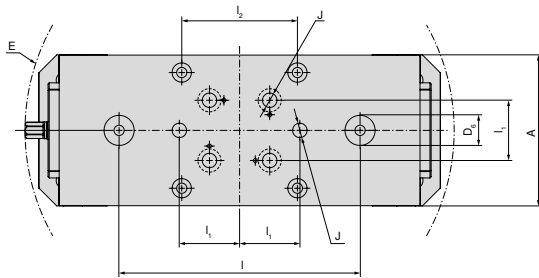

A	D ₆ H ₆	E	I ₁ ±0.015	I ₁ ±0.015	I ₂	J H ₇
mm	mm	mm	mm	mm	mm	mm
125	25	357	200	50	96	12

Rozmery spodnej strany zveráka ESG 5

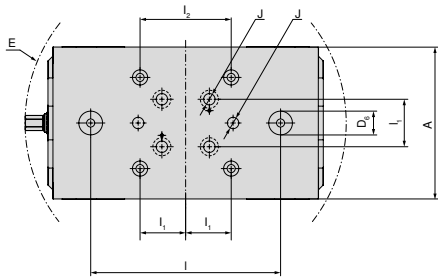
Šírka základného telesa 160 mm,
dĺžka 280 mm

A	D ₆ H6	E	I _{±0,015}	I _{1 ±0,015}	I ₂	J H7
mm	mm	mm	mm	mm	mm	mm
160	25	339	200	50	96	12

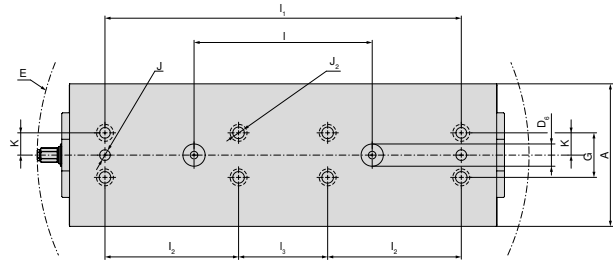
Šírka základného telesa 160 mm,
dĺžka 480 mm

A	D ₆ H6	E	I _{±0,015}	I _{1 ±0,015}	I ₂	I _{3 ±0,015}	J H7	J ₂ F7	K _{±0,02}	G
mm	mm	mm	mm	mm	mm	mm	mm	mm	mm	mm
160	25	553	200	400	150	100	12	12	25	50

ESG 5 rozmerová tabuľka pre rôzne čeluste

S otočnou čelustou grip 3 mm, pevná a pohyblivá

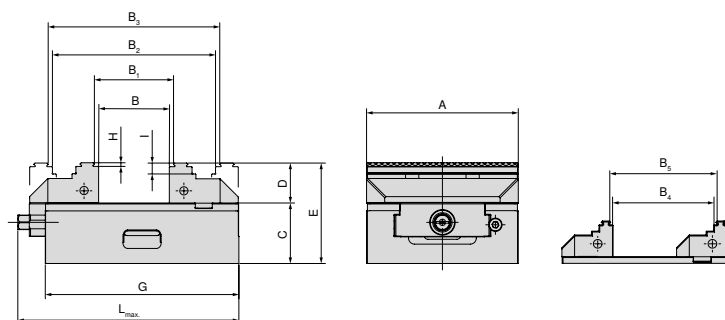

A mm	B mm	B ₁ mm	B ₂ mm	B ₃ mm	B ₄ mm	B ₅ mm	C mm	D mm	E mm	G mm	H mm	I mm	L _{max.} mm	Artikel č. Systémové čeluste
80	0-49	4-53	59-107	63-111	30-78	34-82	50	28	78	130	3	8	155	80 901 306 + 80 878 810
80	0-109	4-113	59-167	63-171	29-134	35-136	50	28	78	190	3	8	206	80 901 306 + 80 878 810
125	0-57	8-64	77-134	84-141	40-95	47-102	50	33	83	160	3	9	183	80 857 30000 + 80 878 510
125	0-127	8-134	77-204	84-211	40-165	47-172	50	33	83	235	3	9	250	80 857 30000 + 80 878 510
125	0-197	8-204	77-274	84-281	40-235	47-242	50	33	83	300	3	9	320	80 857 30000 + 80 878 510
160	0-121	8-128	118-238	125-245	-	-	70	50	120	280	3	10	328	80 901 300 + 80 878 610
160	0-324	8-331	118-441	125-448	-	-	70	50	120	480	3	10	506	80 901 300 + 80 878 610

S 5 osovými čelustami

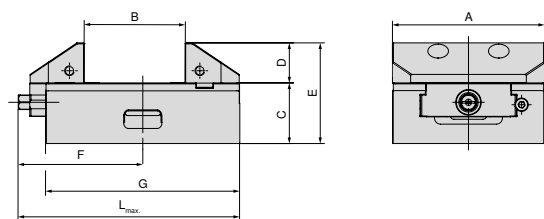

A mm	B mm	C mm	D mm	E mm	F mm	G mm	L _{max.} mm	Artikel č. Systémové čeluste
125	25-82	50	33	83	103	160	183	80 857 30200 + 80 857 30100
125	25-152	50	33	83	132	235	250	80 857 30200 + 80 857 30100
125	25-222	50	33	83	170	300	320	80 857 30200 + 80 857 30100

Prehľad systémových čelustí

Otočná čelusť, hladká, pevná

▲ cena za kus

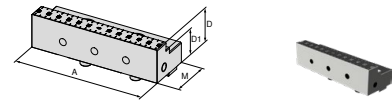

pre šírku zveráka	A	A ₁	D	D ₁	D ₂	E	M	M ₁	M ₂	EUR	Y4	NCG	H5G / -S / -Z	X5G-Z / -S	ESG 4	ESG 5	HDG 2	ZSG 4	ZSG mini	DSG 4	Verso	HSG	
80	80		28	20			40			195,00							●						
125	125		33	25			57			378,00							●						

Otočná čelusť, hladká, pohyblivá

▲ cena za kus

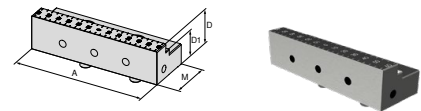

pre šírku zveráka	A	A ₁	D	D ₁	D ₂	E	M	M ₁	M ₂	EUR	Y4	NCG	H5G / -S / -Z	X5G-Z / -S	ESG 4	ESG 5	HDG 2	ZSG 4	ZSG mini	DSG 4	Verso	HSG	
80	80		28	20			40			195,00							●						
125	125		33	25			57			378,00							●						

Otočná čelusť, grip 3 mm, pevná

▲ cena za kus

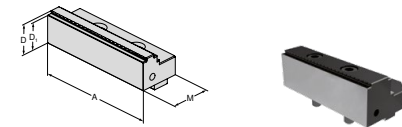

pre šírku zveráka	A	A ₁	D	D ₁	D ₂	E	M	M ₁	M ₂	EUR	Y4	NCG	H5G / -S / -Z	X5G-Z / -S	ESG 4	ESG 5	HDG 2	ZSG 4	ZSG mini	DSG 4	Verso	HSG	
80	80		28	25			40			163,00					●	●							
125	125		33	30			57			222,00					●	●							
160	160		50	47			81			404,00					●	●							

Otočná čelusť, grip 3 mm, pohyblivá

▲ cena za kus

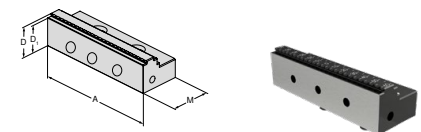

pre šírku zveráka	A	A ₁	D	D ₁	D ₂	E	M	M ₁	M ₂	EUR	Y4	NCG	H5G / -S / -Z	X5G-Z / -S	ESG 4	ESG 5	HDG 2	ZSG 4	ZSG mini	DSG 4	Verso	HSG	
80	80		28	25			40			135,00					●	●							
125	125		33	30			57			151,00					●	●							
160	160		50	47			81			404,00					●	●							

Prehľad systémových čelustí

5osová čelusť, pevná

▲ cena za kus

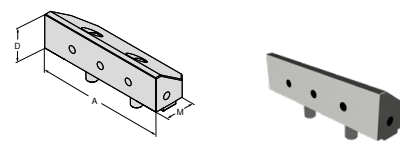

pre šírku zveráka	A	A ₁	D	D ₁	D ₂	E	M	M ₁	M ₂	EUR	Y4	NCG	H5G / -S / -Z	X5G-Z / -S	ESG 4	ESG 5	HDG 2	ZSG 4	ZSG mini	DSG 4	Verso	HSG		
125	125		33				44,5			224,00						●								

5osová čelusť, pohyblivá

▲ cena za kus

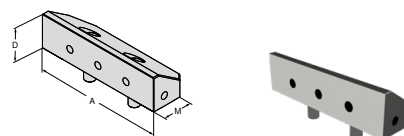

pre šírku zveráka	A	A ₁	D	D ₁	D ₂	E	M	M ₁	M ₂	EUR	Y4	NCG	H5G / -S / -Z	X5G-Z / -S	ESG 4	ESG 5	HDG 2	ZSG 4	ZSG mini	DSG 4	Verso	HSG		
125	125		33				44,5			224,00						●								

Mäkká čelusť, oceľ, pevná

▲ materiál: 16MnCr5

▲ pre výrobu tvarových čelustí

▲ cena za kus

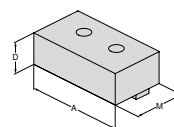

pre šírku zveráka	A	A ₁	D	D ₁	D ₂	E	M	M ₁	M ₂	EUR	Y4	NCG	H5G / -S / -Z	X5G-Z / -S	ESG 4	ESG 5	HDG 2	ZSG 4	ZSG mini	DSG 4	Verso	HSG		
80	80		28				48			104,00					●	●								
125	125		40				68			125,00					●	●								

Mäkká čelusť, oceľ, pohyblivá

▲ materiál: 16MnCr5

▲ pre výrobu tvarových čelustí

▲ cena za kus

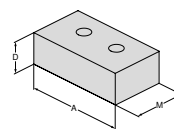

pre šírku zveráka	A	A ₁	D	D ₁	D ₂	E	M	M ₁	M ₂	EUR	Y4	NCG	H5G / -S / -Z	X5G-Z / -S	ESG 4	ESG 5	HDG 2	ZSG 4	ZSG mini	DSG 4	Verso	HSG		
80	80		28				48			89,10					●	●								
125	125		40				68			112,00					●	●								

HDG 2

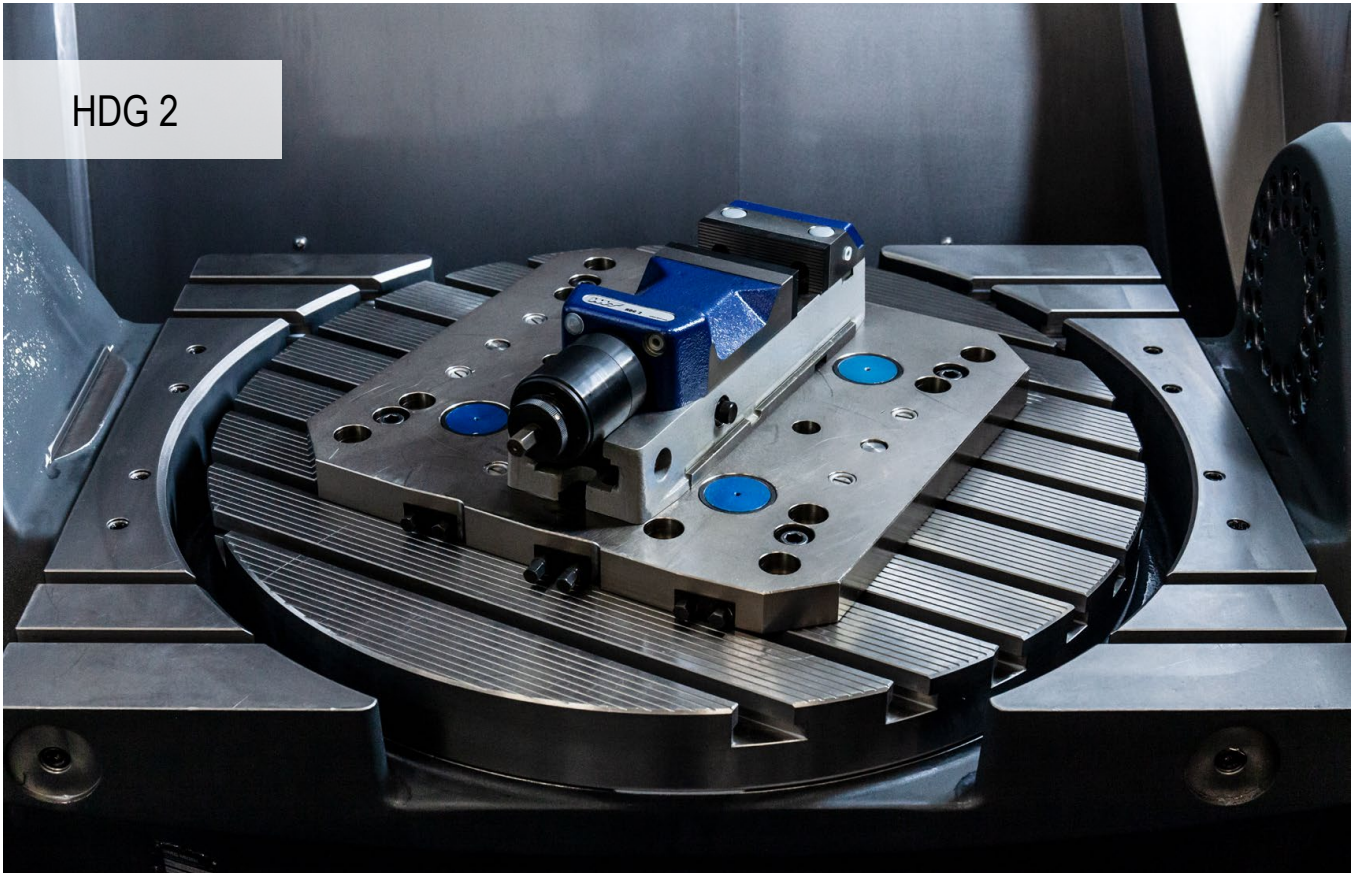

Osvedčený vysokotlakový upínací systém

Mechanický strojný zverák s plynulým nastavením upínacej sily od 10 %, upnutie do 100 % iba jediným otočením kľukou a s konštantnou koncovou polohou kľuky. Rýchle nastavenie upínacieho rozsahu pomocou kolíkov.

Výhody pre Vás:

- ▲ úspora času aj úsilia – iba 1 otočenie kľukou
- ▲ upínací čas <1 sekunda
- ▲ jednoduchá manipulácia
- ▲ možnosť plynulého nastavenia bez použitia náradia
- ▲ vysoká presnosť obrábania

Upnutie / Vyrovnávanie:



Vyrovnávanie do T drážok stola pomocou kameňov lícovaných do drážok š. 20^{H7} (pozdlžnych lebo priečnych) v základnom telese.



Upínanie pomocou skrutiek cez základné teleso alebo z boku pomocou úpiniek.

SoloClamp – HDG 2

- ▲ vysokotlakový zverák
- ▲ plynulé nastavenie sily
- ▲ mechanický prenos sily
- ▲ upínacej sily sa dosiahne iba jedným otočením kľuky
- ▲ flexibilné čeluste, pripravené pre montáž čelustí pre rozšírenie upínacieho rozsahu

Rozsah dodávky:

Vysokotlakový zverák vr. 4 upínacích pätičk, ručnej kľuky, 2 profilových a kalených pedsadených čelustí

**HDG
2**

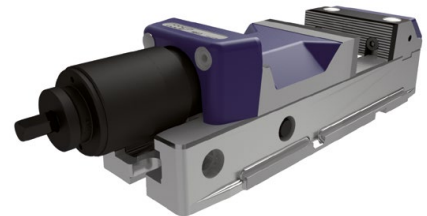
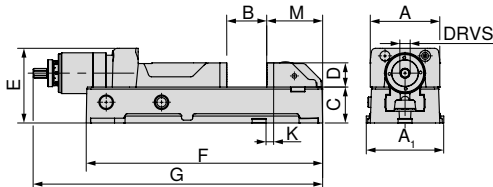

A	A ₁	B	C ^{+0/-0.02}	D	E	F	G _{max}	K _{±0.015}	M	DRVS	MXC	WT	80 892 ...
mm	mm	mm	mm	mm	mm	mm	mm	mm	mm	mm	kN	kg	EUR Y4
100	112	0 - 159	52	35	108	342	521	11	81	12	4 - 30	20	2.050,00 100
125	140	0 - 201	62	40	118	400	584	28	85	12	4 - 40	27	2.340,00 125
160	176	0 - 300	78	50	149	544	784	40	112	12	5 - 60	55	3.470,00 160

Prehľad zverákov

Rozmery spodnej strany	71	Systémové príslušenstvo	69-71
Obecné príslušenstvo	164-183		

Prehľad systémových čelustí

Čeluste pre rozšírenie upínacieho rozsahu

- ▲ cena za súpravu (1 pevná a 1 pohyblivá čelusť)

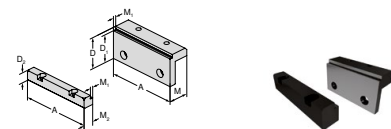

pre šírku zveráka	A	A ₁	D	D ₁	D ₂	E	M	M ₁	M ₂	EUR	Y4	NCG	H5G / +S / -Z	X5G-Z / -S	ESG 4	ESG 5	HDG 2	ZSG 4	ZSG mini	DSG 4	Verso	HSG	
100			56	50	22		37	5	19	366,00	80 892 225							●					
125			56	50	22		37	5	19	494,00	80 892 226							●					
160			71	65	23		47	5	23,5	537,00	80 892 227							●					

Prevedenie s rozšíreným upínacím rozsahom



A	B	D	Artikel č. – zverák	Artikel č. – čeluste
100	118 - 278	56	80 892 100	80 892 225
125	137 - 338	56	80 892 125	80 892 226
160	169 - 470	71	80 892 160	80 892 227

SoloClamp – HDG 2

▲ predĺženie základného telesa

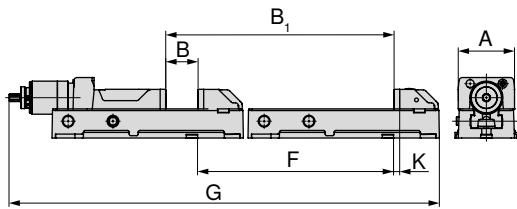
HDG
2

A	B	B ₁	F	G	K
mm	mm	mm	mm	mm	mm
100	0-159	350-509	450	871,3	11
125	0-201	410-611	410	994,1	28
160	0-300	550-850	550	1334,15	40

80 892 ...

EUR
Y4

1.160,00 51000

1.280,00 51100

1.740,00 51200

Zobrazenie s predĺžením základného telesa

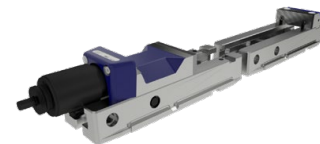

A	B	D	Artikel č. – zverák	Artikel č. predĺženie
100	350 - 509	35	80 892 100	80 892 51000
125	410 - 611	40	80 892 125	80 892 51100
160	550 - 850	50	80 892 160	80 892 51200

Rozmery spodnej strany HDG 2

Šírka základného telesa

100 mm, 125 mm, 160 mm

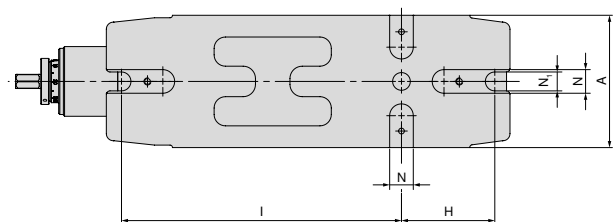

A mm	H mm	I mm	N _{H7} mm	N ₁ mm
100	80	240	20	15
125	100	280	20	18
160	130	380	20	22

Prehľad systémového príslušenstva

Uhlový pohon

HDG
2



80 892 ...

Pre šírku
mm

EUR
Y4

100/125

460,00 314

160

499,00 315

Ručná kľuka

▲ pre rýchle nastavenie

HDG
2



80 892 ...

Pre šírku
mm

EUR
Y4

100/125

76,60 124

160

95,00 164

ZSG 4



Optimalizovaný zverák ZSG 4 – Maximálna precíznosť a procesná bezpečnosť

Nový zverák ZSG 4 preberá všetky obľúbené vlastnosti svojho predchodcu a značne zdvíha latku v oblasti užívateľskej prívetivosti a životnosti. Prioritou pri optimalizácii obľúbeného osového zveráka bolo zabezpečenie lepšej manipulácie a dlhšej životnosti.

Výhody pre Vás:

- ▲ obzvlášť vhodné na obojstranné obrábanie vďaka vysokej uhlovej presnosti
- ▲ kompaktný design umožňuje optimálny prístup
- ▲ jednoduchá a rýchla výmena čelustí, pomocou dvoch skrutiek
- ▲ rovnaké upínacie rozsahy, oveľa lepší vonkajší obrys bez kolíznych prvkov, rozsiahla ponuka modulárnych čelustí
- ▲ odolný model s poniklovaným základným telesom garantuje dlhú životnosť



Upnutie / Vyrovnávanie:



Upínanie pomocou upínacieho systému s nulovým bodom.
ZSG 4 – 80 mm L-130 mm + L-190 mm
ZSG 4 – 125 mm L-160 mm + L-235 mm

1 upínací čap MNG + polohovací kolík



Upínanie pomocou upínacieho systému s nulovým bodom.
ZSG 4 – 125 mm + L-300 mm
ZSG 4 – 160 mm + L-280 mm + L-480 mm

2 upínacie čapy



Vo všetkých variantoch sú vždy k dispozícii presné otvory $\varnothing 12^{IS}$, pomocou ktorých je možné zverák ZSG 4 precízne polohovať. Všetky varianty je možné pripevňovať pomocou skrutiek zhora cez základné teleso.

Upnutie / Vyrovnávanie:



ZSG 4 – 125 mm L-235 mm + L-300 mm
ZSG 4 – 160 mm L-280 mm + L-480 mm

Tieto 4 varianty je možné alternatívne upínať aj pomocou úpiniek.



ZSG 4 – 80 mm L-130 mm + L-190 mm
ZSG 4 – 125 mm L-160 mm + L-235 mm + L-300 mm
ZSG 4 – 160 mm L-280 mm

Všetkých 5 variantov je k dispozícii aj s upínacími otvormi pre upínací systém s nulovým bodom LANG.

Upínacia sila:

Utahovací moment / upínacia sila ZSG 4 – 80 mm

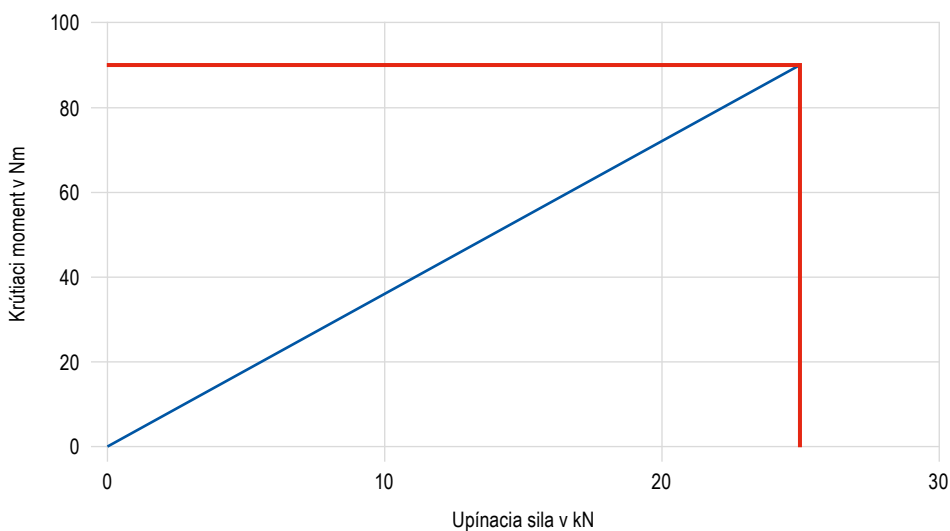

Upínacia sila:

Uťahovací moment / upínacia sila ZSG 4 – 125 mm

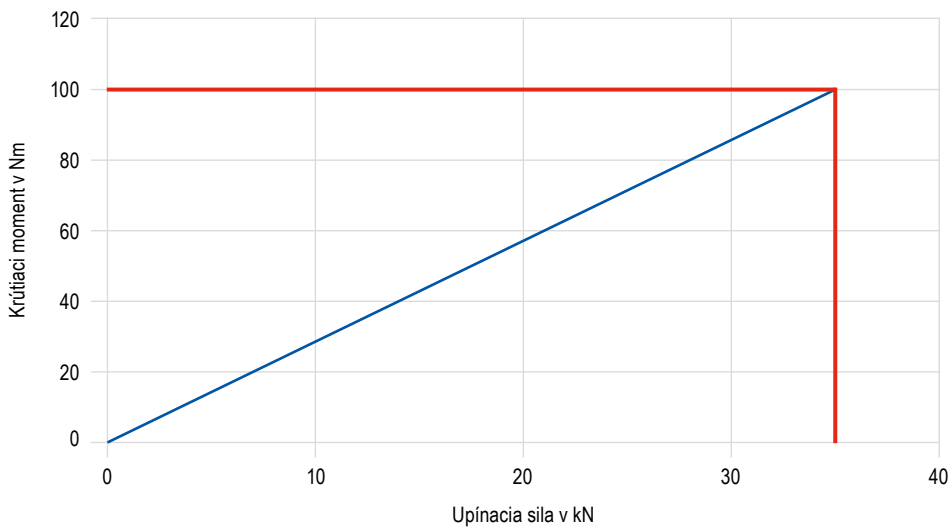

Uťahovací moment / upínacia sila ZSG 4 – 160 mm

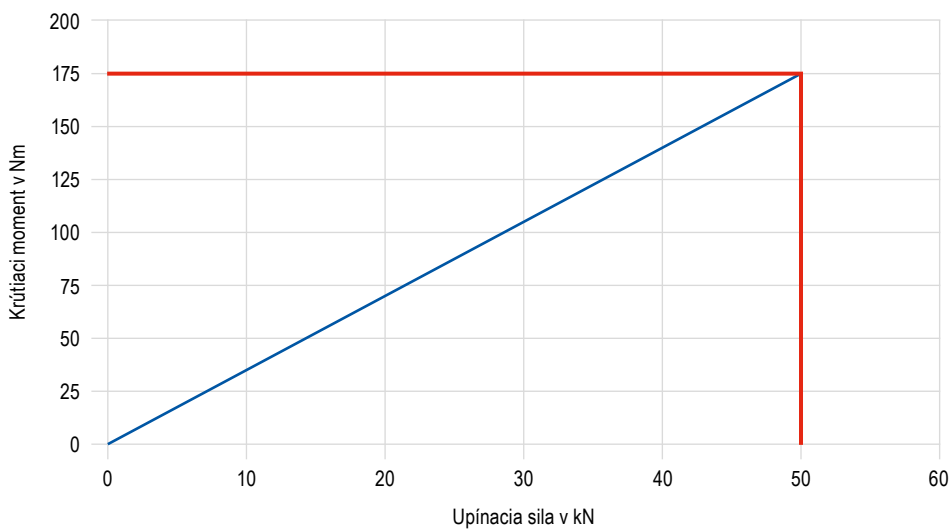

CentriClamp – ZSG 4

- ▲ zapuzdrený osový zverák
- ▲ bez systémových čelustí
- ▲ vreteno s guľôčkovými ložiskami
- ▲ presnosť opakovania $\pm 0,01$ mm medzi dvomi upínacími operáciami
- ▲ vhodný pre PNG a MNG

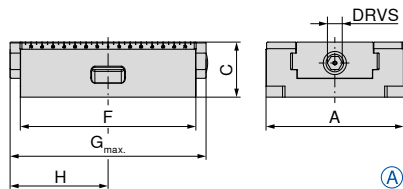
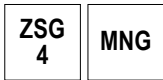

Ovládanie vretena: zapustený šesťhran

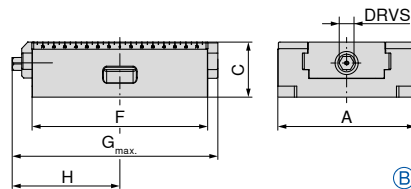

Ovládanie vretena: predsadený šesťhran



A mm	C _{±0,01} mm	F mm	G _{max.} mm	H mm	DRVS mm	MXC kN	WT kg	Označenie	80 878 ...	
									EUR	Y4
80	50	130	157	81	12	25	3,1	A	553,00	08500
80	50	190	206	104	12	25	4,5	B	665,00	08600
125	50	160	200	111,5	12	35	6,3	A	726,00	15000
125	50	235	272	143,5	12	35	9,5	B	927,00	15100
125	50	300	340	181	12	35	12,5	B	1.130,00	15200
160	70	280	315	172	14	50	25,0	A	1.710,00	26100
160	70	480	524	276	14	50	35,0	B	3.230,00	26200

Vhodný pre upínací systém s nulovým bodom							LANG Quick Point	
Artikel č.	Typ	Šírka v mm	Dĺžka v mm	MNG	MNG mini	PNG	96 x 96	52 x 52
80 878 08500	ZSG 4	80	130	✓	✓	✗	✗	✓
80 878 08600		80	190	✓	✗	✓	✗	✓
80 878 15000		125	160	✓	✗	✓	✓	✓
80 878 15100		125	235	✓	✗	✓	✓	✗
80 878 15200		125	300	✓	✗	✓	✓	✗
80 878 26100		160	280	✓	✗	✓	✓	✗
80 878 26200		160	480	✓	✗	✓	✗	✗

Prehľad zverákov

Rozmery spodnej strany	78+79	Rozmerové tabuľky pre rôzne čeluste	80-83
Systémové príslušenstvo	85-90	Upínací systém s nulovým bodom MNG/PNG	134-163
Obecné príslušenstvo	164-183		

CentriClamp – ZSG 4

- ▲ zapuzdrený osový zverák
- ▲ s upínacími čelustami grip 3 mm
- ▲ vreteno vybavené guľôčkovými ložiskami
- ▲ presnosť opakovania ±0,01 mm medzi dvomi upínacími operáciami
- ▲ vhodný pre PNG a MNG

ZSG 4 MNG

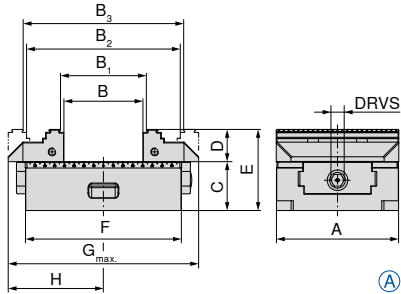

Ovládanie vretena: zapustený šesťhran

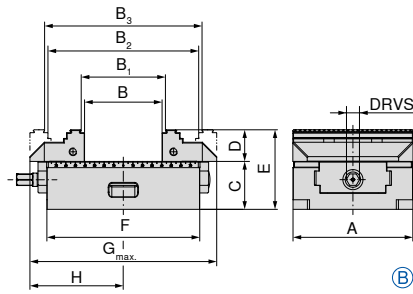

Ovládanie vretena: predsadený šesťhran



80 878 ...

A	B	B ₁	B ₂	B ₃	C ±0,01	D	E	F	G _{max}	H	DRVS	MXC	WT	Označenie	EUR
mm	mm	mm	mm	mm	mm	mm	mm	mm	mm	mm	mm	kN	kg		Y4
80	0 - 59	4 - 63	59 - 117	63 - 121	50	28	78	130	157	81	12	25	3,9	A	777,00 08700
80	0 - 123	4 - 127	59 - 181	63 - 185	50	28	78	190	206	104	12	25	5,5	B	889,00 08800
125	0 - 80	8 - 87	77 - 156	84 - 163	50	33	83	160	208	111,5	12	35	8,7	A	980,00 15300
125	0 - 155	8 - 162	77 - 218	84 - 225	50	33	83	235	272	143,5	12	35	12,0	B	1.180,00 15400
125	0 - 220	8 - 227	77 - 296	84 - 303	50	33	83	300	348	181	12	35	14,0	B	1.390,00 15500



Tu pre š. 125 mm nepasujú čeluste s výškou 40 mm, v prípade, že sú potrebné, je nutné sa vybaviť otočnými čelustami s výškou D = 40 mm (80 878 520).

Vhodný pre upínací systém s nulovým bodom							LANG Quick Point		LANG Quick Point	
Artikel č.	Typ	Šírka v mm	Dĺžka v mm	MNG	MNG mini	PNG	96 x 96	52 x 52		
80 878 08700	ZSG 4	80	130	✓	✓	✗	✗	✓		
80 878 08800		80	190	✓	✗	✓	✗	✓		
80 878 15300		125	160	✓	✗	✓	✓	✓		
80 878 15400		125	235	✓	✗	✓	✓	✗		
80 878 15500		125	300	✓	✗	✓	✓	✗		

Prehľad zverákov

Rozmery spodnej strany	78+79	Rozmerové tabuľky pre rôzne čeluste	80-83
Systémové príslušenstvo	85-90	Upínací systém s nulovým bodom MNG/PNG	134-163
Obečné príslušenstvo	164-183		

CentriClamp – ZSG 4

- ▲ zapuzdrený osový zverák pre Erowa ITS 148
- ▲ bez systémových čelustí
- ▲ vreteno s guľôčkovými ložiskami
- ▲ presnosť opakovania $\pm 0,01$ mm medzi dvomi upínacími operáciami

ZSG 4	MNG
----------	-----

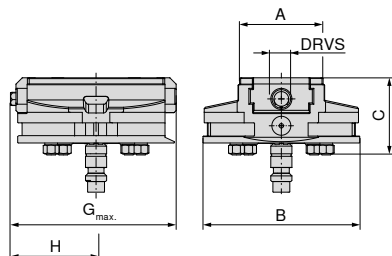

80 878 ...

EUR
Y4

1.370,00 08900

A	B	C	G _{max.}	H	DRVS	MXC	WT
mm	mm	mm	mm	mm	mm	kN	kg
80	148	73	157	81	12	25	5,6

Prehľad zverákov

Rozmery spodnej strany	78+79	Rozmerové tabuľky pre rôzne čeluste	80–83
Systémové príslušenstvo	85–90	Upínací systém s nulovým bodom MNG/PNG	134–163
Obecné príslušenstvo	164–183		

Rozmery spodnej strany zveráka ZSG 4

Šírka základného telesa 80 mm,
dĺžka 130 mm

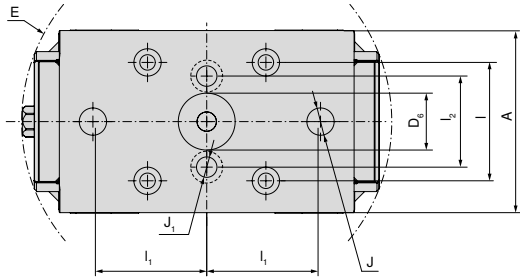

A	D ₆ H ₆	E	I ₁ ±0.015	I ₁ ±0.015	I ₂	J H ₇	J ₁
mm	mm	mm	mm	mm	mm	mm	mm
80	25	163	52	50	40	12	9

Šírka základného telesa 80 mm,
dĺžka 190 mm

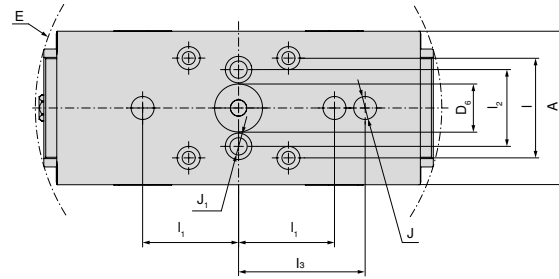

A	D ₆ H ₆	E	I ₁ ±0.015	I ₁ ±0.015	I ₂	I ₃ ±0.015	J H ₇	J ₁
mm	mm	mm	mm	mm	mm	mm	mm	mm
80	25	213	52	50	40	66	12	9

Šírka základného telesa 125 mm,
dĺžka 160 mm

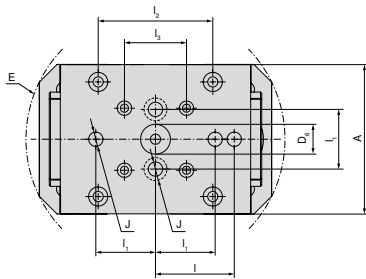

A	D ₆ H ₆	E	I ₁ ±0.015	I ₁ ±0.015	I ₂	I ₃ ±0.015	J H ₇
mm	mm	mm	mm	mm	mm	mm	mm
125	25	218	66	50	96	52	12

Šírka základného telesa 125 mm,
dĺžka 235 mm

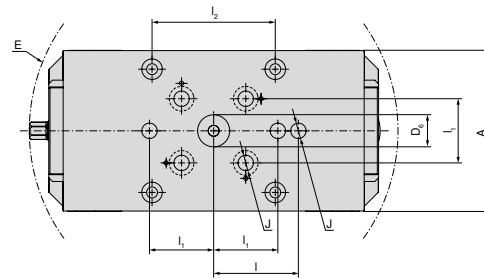

A	D ₆ H ₆	E	I ₁ ±0.015	I ₁ ±0.015	I ₂	J H ₇
mm	mm	mm	mm	mm	mm	mm
125	25	288	66	50	96	12

Šírka základného telesa 125 mm,
dĺžka 300 mm

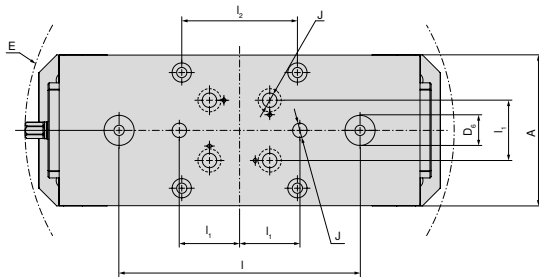

A	D ₆ H ₆	E	I ₁ ±0.015	I ₁ ±0.015	I ₂	J H ₇
mm	mm	mm	mm	mm	mm	mm
125	25	357	200	50	96	12

Rozmery spodnej strany zveráka ZSG 4

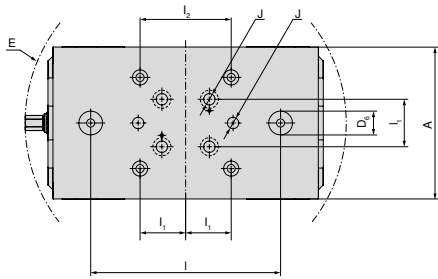
Šírka základného telesa 160 mm,
dĺžka 280 mm

A	D ₆ H6	E	I ₁ ±0,015	I ₁ ±0,015	I ₂	J H7
mm	mm	mm	mm	mm	mm	mm
160	25	339	200	50	96	12

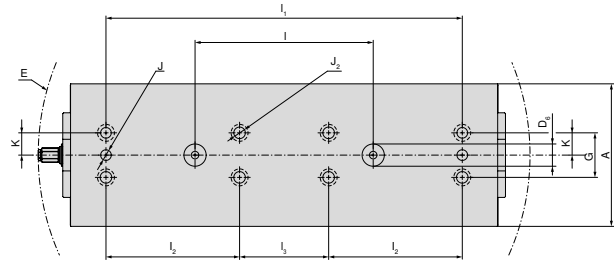
Šírka základného telesa 160 mm,
dĺžka 480 mm

A	D ₆ H6	E	I ₁ ±0,015	I ₁ ±0,015	I ₂	I ₃ ±0,015	J H7	J ₂ F7	K ±0,02	G
mm	mm	mm	mm	mm	mm	mm	mm	mm	mm	mm
160	25	553	200	400	150	100	12	12	25	50

ZSG 4 rozmerová tabuľka pre rôzne čeluste

S kombinovanými čelustami

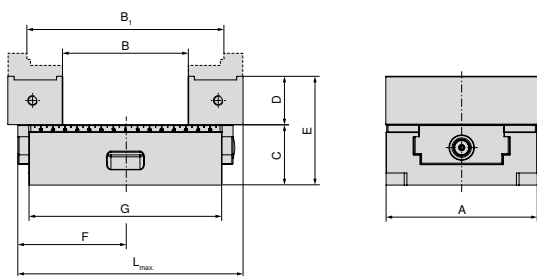

A mm	B mm	B ₁ mm	C mm	D mm	E mm	F mm	G mm	L _{max} mm	Artikel č. Systémové čeluste
125	23 - 103	82 - 161	50	40	90	111,5	160	208	2 x 80 878 530
125	23 - 165	82 - 223	50	40	90	143,5	235	272	2 x 80 878 530
125	23 - 241	82 - 300	50	40	90	181	300	348	2 x 80 878 530

S výkyvnou a adaptérovou čelustou

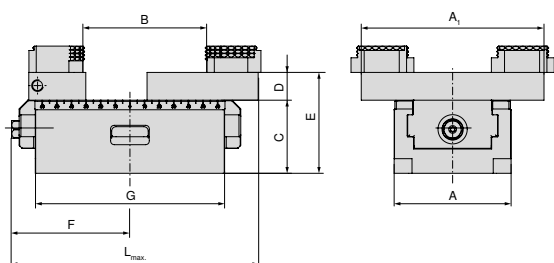

A mm	A ₁ mm	B mm	C mm	D mm	E mm	F mm	G mm	L _{max} mm	Artikel č. Systémové čeluste
80	125	3 - 84	50	28	78	81	130	157	80 878 890 + 80 878 870
80	125	3 - 145	50	28	78	104	190	206	80 878 890 + 80 878 870
125	180	7 - 126	50	22	90	111,5	160	212	80 878 590 + 80 878 570
125	180	7 - 207	50	22	90	143,5	235	272	80 878 590 + 80 878 570
125	180	7 - 250	50	22	90	181	300	352	80 878 590 + 80 878 570
160	256	16 - 292	70	22	110	170	280	315	80 878 690 + 80 878 670
160	256	16 - 406	70	22	110	276	480	524	80 878 690 + 80 878 670

S hliníkovými čelustami

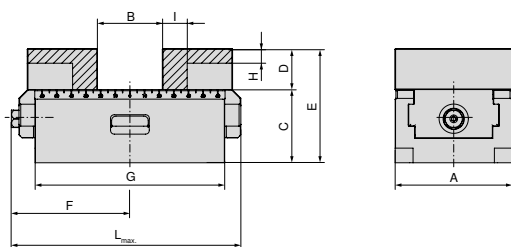

A mm	B mm	C mm	D mm	E mm	F mm	G mm	H mm	I mm	L _{max} mm	Artikel č. Systémové čeluste
80	0 - 44	50	28	78	81	130	10	17	157	2 x 80 878 850
80	0 - 108	50	28	78	104	190	10	17	206	2 x 80 878 850
125	0 - 58	50	40	90	111,5	160	17	27	208	2 x 80 878 550
125	0 - 133	50	40	90	143,5	235	17	27	272	2 x 80 878 550
125	0 - 198	50	40	90	181	300	17	27	348	2 x 80 878 550
160	0 - 123	70	50	120	170	280	26	25	315	2 x 80 878 305
160	10 - 336	70	50	120	276	480	26	25	524	2 x 80 878 305

ZSG 4 rozmerová tabuľka pre rôzne čeluste

S 5 osovými čelustami

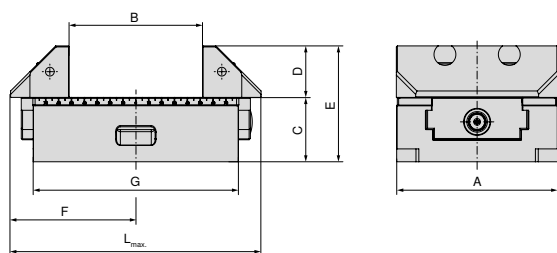

A mm	B mm	C mm	D mm	E mm	F mm	G mm	L _{max} mm	Artikel č. Systémové čeluste
125	22 - 102	50	40	90	115,5	160	208	2 x 80 878 625
125	22 - 165	50	40	90	143,5	235	272	2 x 80 878 625
125	22 - 242	50	40	90	181	300	348	2 x 80 878 625
160	15 - 140	70	50	120	170	280	315	2 x 80 878 660
160	28 - 354	70	50	120	276	480	524	2 x 80 878 660

S 5osovými čelustami, grip 3 mm, šírka 65 mm

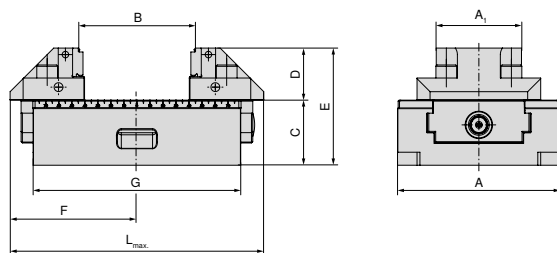

A mm	A ₁ mm	B mm	C mm	D mm	E mm	F mm	G mm	L _{max} mm	Artikel č. Systémové čeluste
125	65	8 - 87	50	40	90	115,5	160	208	2 x 80 878 665
125	65	8 - 162	50	40	90	143,5	235	272	2 x 80 878 665
125	65	8 - 227	50	40	90	181	300	348	2 x 80 878 665

S otočnými čelustami, grip 3 mm, šírka 65 mm

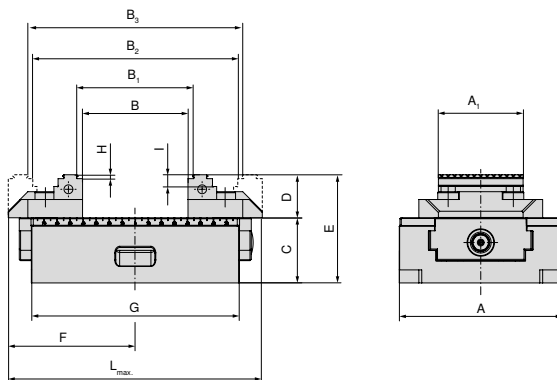

A mm	A ₁ mm	B mm	B ₁ mm	B ₂ mm	B ₃ mm	C mm	D mm	E mm	F mm	G mm	H mm	I mm	L _{max} mm	Artikel č. Systémové čeluste
125	65	0 - 80	8 - 87	77 - 156	84 - 163	50	33	83	111,5	160	3	9	208	2 x 80 878 51900
125	65	0 - 142	8 - 149	77 - 218	84 - 225	50	33	83	143,5	235	3	9	272	2 x 80 878 51900
125	65	0 - 220	8 - 227	77 - 296	84 - 303	50	33	83	181	300	3	9	348	2 x 80 878 51900

ZSG 4 rozmerová tabuľka pre rôzne čeluste

S otočnými čelustami, grip 3 mm

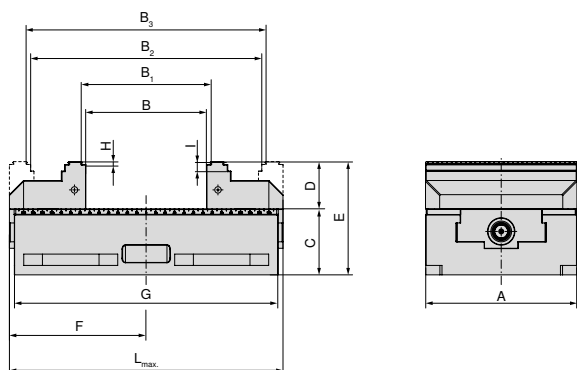

A mm	B mm	B ₁ mm	B ₂ mm	B ₃ mm	C mm	D mm	E mm	F mm	G mm	H mm	I mm	L _{max} mm	Artikel č. Systémové čeluste
160	0 - 127	8 - 134	118 - 244	125 - 251	70	50	120	170	280	3	10	315	2 x 80 878 610
160	15 - 341	22 - 348	132 - 458	139 - 465	70	50	120	276	480	3	10	524	2 x 80 878 610

S otočnými čelustami, grip 3 mm, šírka 40 mm

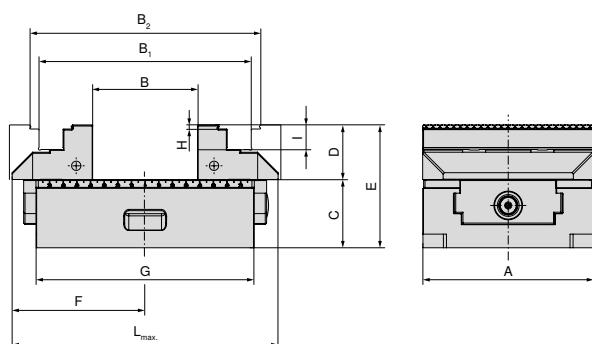

A mm	B mm	B ₁ mm	B ₂ mm	C mm	D mm	E mm	F mm	G mm	H mm	I mm	L _{max} mm	Artikel č. Systémové čeluste
125	0 - 75	75 - 154	88 - 166	50	40	90	111,5	160	3	9	208	2 x 80 878 520
125	0 - 138	75 - 217	88 - 229	50	40	90	143,5	235	3	9	272	2 x 80 878 520
125	0 - 215	75 - 294	88 - 306	50	40	90	181	300	3	9	348	2 x 80 878 520

So systémom 6 násobných čelustí pre šírku čelusti 125 mm

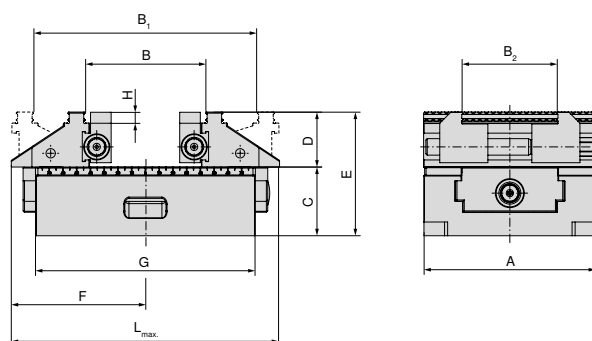

A mm	B mm	B ₁ mm	B ₂ mm	C mm	D mm	E mm	F mm	G mm	H mm	L _{max} mm	Artikel č. Systémové čeluste
125	39 - 86	83 - 161	37 - 101	50	40	90	111,5	160	8	209	80 878 525
125	39 - 149	83 - 224	37 - 101	50	40	90	143,5	235	8	272	80 878 525
125	39 - 226	83 - 301	37 - 101	50	40	90	181	300	8	349	80 878 525

ZSG 4 rozmerová tabuľka pre rôzne čeluste

S otočnou čelustou, grip 3 mm (výška 28 mm / 33 mm) pre šírku čeluste 80 mm a 125 mm

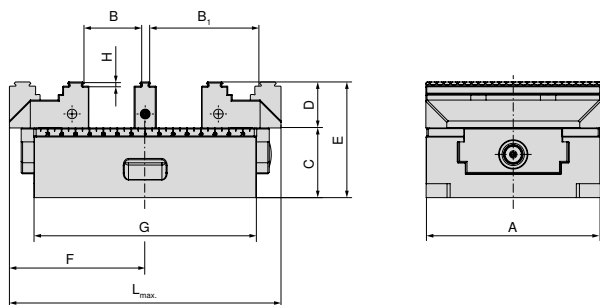

A mm	B mm	B ₁ mm	C mm	D mm	E mm	F mm	G mm	H mm	L _{max.} mm	Artikel č. Systémové čeluste
80	8 - 28	37 - 57	50	28	78	81	130	3	157	2 x 80 878 810 + 80 878 31200
80	14 - 22	31 - 51	50	28	78	81	130	3	157	2 x 80 878 810 + 80 878 33400
80	8 - 58	37 - 87	50	28	78	104	190	3	206	2 x 80 878 810 + 80 878 31200
80	14 - 52	31 - 81	50	28	78	104	190	3	206	2 x 80 878 810 + 80 878 33400
125	9 - 40	47 - 78	50	33	83	111,5	160	3	208	2 x 80 878 510 + 80 878 31300
125	15 - 34	41 - 72	50	33	83	111,5	160	3	208	2 x 80 878 510 + 80 878 33500
125	9 - 72	47 - 110	50	33	83	143,5	235	3	272	2 x 80 878 510 + 80 878 31300
125	15 - 66	41 - 104	50	33	83	143,5	235	3	272	2 x 80 878 510 + 80 878 33500
125	9 - 110	47 - 148	50	33	83	181	300	3	348	2 x 80 878 510 + 80 878 31300
125	15 - 104	41 - 142	50	33	83	181	300	3	348	2 x 80 878 510 + 80 878 33500

S prizmatickou pohyblivou čelustou – s vodorovnou i zvislou prizmou

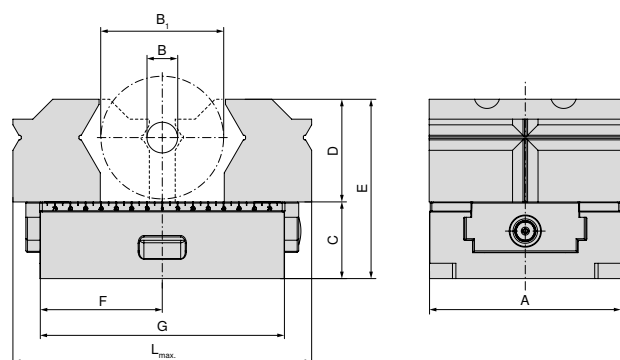

A mm	B mm	B ₁ mm	C mm	D mm	E mm	F mm	G mm	L _{max.} mm	Artikel č. Systémové čeluste
80	10 - 28	20 - 60	50	52	102	81	130	157	2 x 80 878 31800
80	10 - 28	20 - 60	50	52	102	104	190	206	2 x 80 878 31800
125	10 - 28	26 - 80	50	67	117	111,5	160	200	2 x 80 878 31900
125	10 - 28	26 - 80	50	67	117	143,5	235	272	2 x 80 878 31900
125	10 - 28	26 - 80	50	67	117	181	300	348	2 x 80 878 31900

ZSG 4 rozmerová tabuľka pre rôzne čeluste

S prizmatickou pohyblivou čelustou – s vodorovnou prizmou

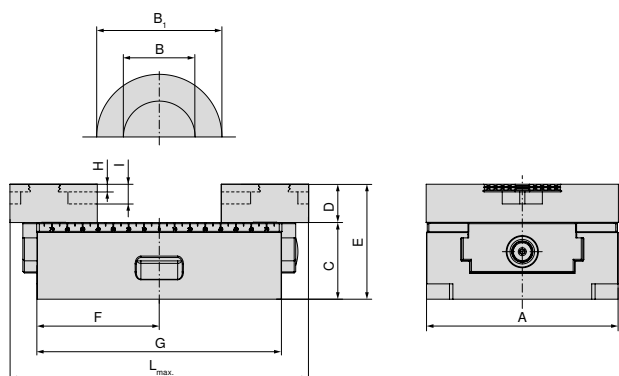

A mm	B mm	B ₁ mm	C mm	D mm	E mm	F mm	G mm	H mm	I mm	L _{max} mm	Artikel č. Systémové čeluste
80	8 - 55	15 - 76	50	25	75	81	130	5	13	157	2 x 80 878 34000
80	8 - 55	15 - 76	50	25	75	104	190	5	13	206	2 x 80 878 34000
125	14 - 102	25 - 112	50	25	75	111,5	160	5	13	200	2 x 80 878 34100
125	14 - 124	25 - 165	50	25	75	143,5	235	5	13	272	2 x 80 878 34100
125	14 - 124	25 - 165	50	25	75	181	300	5	13	348	2 x 80 878 34100
160	22 - 158	32 - 170	70	30	100	145	280	5	13	290	2 x 80 878 34200
160	22 - 158	32 - 170	70	30	100	273	480	5	13	521	2 x 80 878 34200

Prehľad systémových čelustí

5osová čelusť, pohyblivá

▲ cena za kus

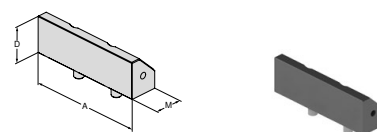

pre šírku zveráka	A	A ₁	D	D ₁	D ₂	E	M	M ₁	M ₂	EUR	Y4	NCG	H5G / -S / -Z	X5G-Z / -S	ESG 4	ESG 5	HDG 2	ZSG 4	ZSG mini	DSG 4	Verso	HSG			
125	125		40				45,5			225,00															
160	160		50				73			277,00									●						

5osová čelusť, grip 3 mm, šírka 65 mm, pohyblivá

▲ cena za kus

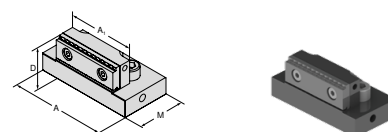

pre šírku zveráka	A	A ₁	D	D ₁	D ₂	E	M	M ₁	M ₂	EUR	Y4	NCG	H5G / -S / -Z	X5G-Z / -S	ESG 4	ESG 5	HDG 2	ZSG 4	ZSG mini	DSG 4	Verso	HSG			
125	95	65,5	40				57			260,00															
																			●						

5osová otočná čelusť, grip 3 mm, šírka 65 mm, pohyblivá

▲ dvojstranný stupeň grip

▲ cena za kus

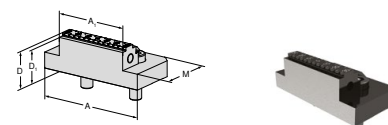

pre šírku zveráka	A	A ₁	D	D ₁	D ₂	E	M	M ₁	M ₂	EUR	Y4	NCG	H5G / -S / -Z	X5G-Z / -S	ESG 4	ESG 5	HDG 2	ZSG 4	ZSG mini	DSG 4	Verso	HSG			
125	95	65	33	30			57			196,00															
																			●						

Otočná čelusť, grip 3 mm, šírka 40 mm, pohyblivá

▲ cena za kus

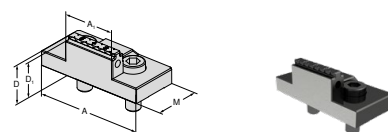

pre šírku zveráka	A	A ₁	D	D ₁	D ₂	E	M	M ₁	M ₂	EUR	Y4	NCG	H5G / -S / -Z	X5G-Z / -S	ESG 4	ESG 5	HDG 2	ZSG 4	ZSG mini	DSG 4	Verso	HSG			
80	80	40	28	25			40			180,00					●										
																			●						

Otočná čelusť, grip 3 mm, výška 40 mm, pohyblivá

▲ cena za kus

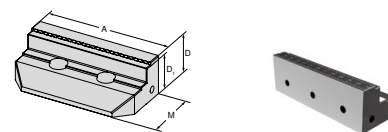

pre šírku zveráka	A	A ₁	D	D ₁	D ₂	E	M	M ₁	M ₂	EUR	Y4	NCG	H5G / -S / -Z	X5G-Z / -S	ESG 4	ESG 5	HDG 2	ZSG 4	ZSG mini	DSG 4	Verso	HSG			
125	125		40	37			59			282,00															
																			●						

Prehľad systémových čelustí

Otočná čelusť, grip 3 mm, pohyblivá

▲ cena za kus

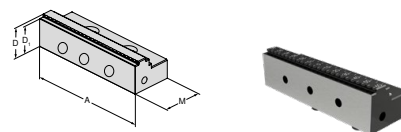

pre šírku zveráka	A	A ₁	D	D ₁	D ₂	E	M	M ₁	M ₂	EUR	Y4	NCG	H5G / -S / -Z	X5G-Z / -S	ESG 4	ESG 5	HDC 2	ZSG 4	ZSG mini	DSG 4	Verso	HSG		
80	80		28	25			40			135,00	80 878 810				●	●		●		●				
125	125		33	30			57			151,00	80 878 510				●	●		●						
160	160		50	47			81			404,00	80 878 610				●	●		●						

Otočná čelusť, grip 5 mm, pohyblivá

▲ cena za kus

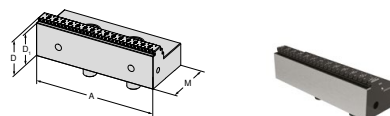

pre šírku zveráka	A	A ₁	D	D ₁	D ₂	E	M	M ₁	M ₂	EUR	Y4	NCG	H5G / -S / -Z	X5G-Z / -S	ESG 4	ESG 5	HDC 2	ZSG 4	ZSG mini	DSG 4	Verso	HSG		
80	80		28	23			41			160,00	80 878 81400				●			●		●				
125	125		33	28			57			177,00	80 878 51400				●			●			●			
160	160		50	45			81			404,00	80 878 34300				●			●						

Otočná čelusť, grip na hliník a plast

▲ cena za kus

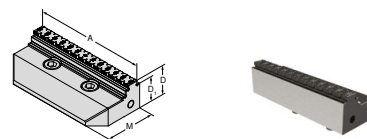

pre šírku zveráka	A	A ₁	D	D ₁	D ₂	E	M	M ₁	M ₂	EUR	Y4	NCG	H5G / -S / -Z	X5G-Z / -S	ESG 4	ESG 5	HDC 2	ZSG 4	ZSG mini	DSG 4	Verso	HSG		
80	80		28	23			40			191,00	80 878 81500							●						
125	125		33	28			57			210,00	80 878 51500							●						

Otočná čelusť s vyrazením, pohyblivá

▲ zhodné s profilom LANG

▲ cena za kus

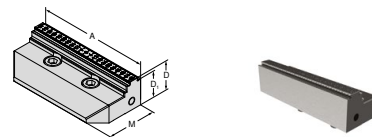

pre šírku zveráka	A	A ₁	D	D ₁	D ₂	E	M	M ₁	M ₂	EUR	Y4	NCG	H5G / -S / -Z	X5G-Z / -S	ESG 4	ESG 5	HDC 2	ZSG 4	ZSG mini	DSG 4	Verso	HSG		
80	80		28	25			40			170,00	80 878 81800							●						
125	125		33	30			57			233,00	80 878 51800							●						

Prehľad systémových čelustí

Otočná čelusť, karbid, grip 3 mm, pohyblivá

▲ cena za kus

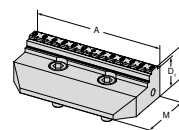

pre šírku zveráka	A	A ₁	D	D ₁	D ₂	E	M	M ₁	M ₂	EUR	Y4	NCG	H5G / -S / -Z	X5G-Z / -S	ESG 4	ESG 5	HDG 2	ZSG 4	ZSG mini	DSG 4	Verso	HSG	
80	80		28	25			40			242,00	80 878 81600												
125	125		33	30			57			342,00	80 878 51600								●				
160	160		50	47			81			537,00	80 878 31700								●				

Otočná čelusť, karbid, grip 5 mm, pohyblivá

▲ cena za kus

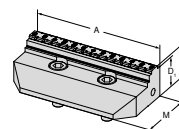

pre šírku zveráka	A	A ₁	D	D ₁	D ₂	E	M	M ₁	M ₂	EUR	Y4	NCG	H5G / -S / -Z	X5G-Z / -S	ESG 4	ESG 5	HDG 2	ZSG 4	ZSG mini	DSG 4	Verso	HSG	
80	80		28	23			40			242,00	80 878 81700								●				
125	125		33	28			57			342,00	80 878 51700								●				

Otočná čelusť, karbid, grip 3 mm, šírka 40 mm, pohyblivá

▲ cena za kus

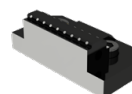
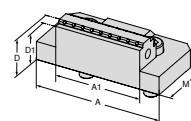

pre šírku zveráka	A	A ₁	D	D ₁	D ₂	E	M	M ₁	M ₂	EUR	Y4	NCG	H5G / -S / -Z	X5G-Z / -S	ESG 4	ESG 5	HDG 2	ZSG 4	ZSG mini	DSG 4	Verso	HSG	
80	80	40	28	25			40			234,00	80 878 33200								●				

Otočná čelusť, karbid, grip 3 mm, šírka 65 mm, pohyblivá

▲ cena za kus

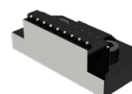
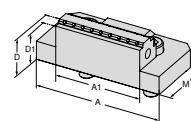

pre šírku zveráka	A	A ₁	D	D ₁	D ₂	E	M	M ₁	M ₂	EUR	Y4	NCG	H5G / -S / -Z	X5G-Z / -S	ESG 4	ESG 5	HDG 2	ZSG 4	ZSG mini	DSG 4	Verso	HSG	
125	125	65	33	30			57			324,00	80 878 33300								●				

Otočná čelusť, hladká, pohyblivá

▲ cena za kus

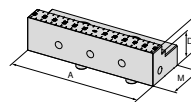

pre šírku zveráka	A	A ₁	D	D ₁	D ₂	E	M	M ₁	M ₂	EUR	Y4	NCG	H5G / -S / -Z	X5G-Z / -S	ESG 4	ESG 5	HDG 2	ZSG 4	ZSG mini	DSG 4	Verso	HSG	
80	80		28	20			40			195,00	80 878 34700					●			●				
125	125		33	25			57			378,00	80 878 34600					●			●				

Prehľad systémových čelustí

Stupňovitá čelusť, hladká, pohyblivá

▲ cena za kus

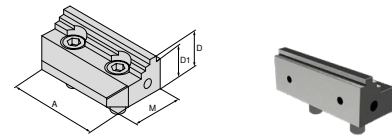

pre šírku zveráka	A	A ₁	D	D ₁	D ₂	E	M	M ₁	M ₂	EUR	Y4	NCG	H5G / -S / -Z	X5G-Z / -S	ESG 4	ESG 5	HDG 2	ZSG 4	ZSG mini	DSG 4	Verso	HSG	
80	80		28	24			40			247,00	80 878 34400								●				
125	125		33	27			57			347,00	80 878 34500								●				

Stredová čelusť, grip 3 mm, úzka

▲ cena za kus

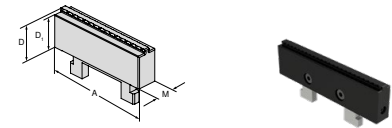

pre šírku zveráka	A	A ₁	D	D ₁	D ₂	E	M	M ₁	M ₂	EUR	Y4	NCG	H5G / -S / -Z	X5G-Z / -S	ESG 4	ESG 5	HDG 2	ZSG 4	ZSG mini	DSG 4	Verso	HSG	
80	80		28	25			16			110,00	80 878 31200								●				
125	125		33	30			16			155,00	80 878 31300								●				

Stredová čelusť, grip 3 mm, široká

▲ cena za kus

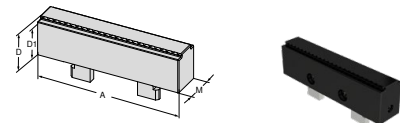

pre šírku zveráka	A	A ₁	D	D ₁	D ₂	E	M	M ₁	M ₂	EUR	Y4	NCG	H5G / -S / -Z	X5G-Z / -S	ESG 4	ESG 5	HDG 2	ZSG 4	ZSG mini	DSG 4	Verso	HSG	
80	80		28	25			24			110,00	80 878 33400								●				
125	125		33	30			26			155,00	80 878 33500								●				

Prizmatická čelusť, pohyblivá

▲ s vodorovnou i zvislou prizmou

▲ cena za kus

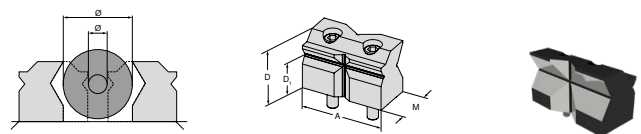

Ø pre upínací priemer	A	A ₁	D	D ₁	D ₂	E	M	M ₁	M ₂	EUR	Y4	NCG	H5G / -S / -Z	X5G-Z / -S	ESG 4	ESG 5	HDG 2	ZSG 4	ZSG mini	DSG 4	Verso	HSG	
10 - 60	80		52	32			38,5			319,00	80 878 31800								●				
10 - 80	125		67	42			57			486,00	80 878 31900								●				

Prehľad systémových čelustí

Prizmatická čelusť, pohyblivá

- ▲ s vodorovnou prizmou
- ▲ cena za kus

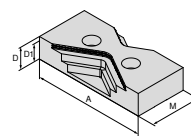
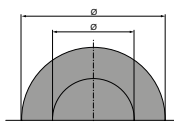

Ø pre upínací priemer	A	A ₁	D	D ₁	D ₂	E	M	M ₁	M ₂	EUR	Y4	NCG	H5G / -S / -Z	X5G-Z / -S	ESG 4	ESG 5	HDG 2	ZSG 4	ZSG mini	DSG 4	Verso	HSG	
15 - 75	80		25	20			40			171,00	80 878 34000								●				
25 - 110	125		25	20			57			220,00	80 878 34100								●				
30 - 170	160		30	25			81			285,00	80 878 34200								●				

Kombinovaná čelusť, pohyblivá

- ▲ cena za kus

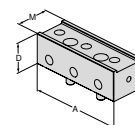

pre šírku zveráka	A	A ₁	D	D ₁	D ₂	E	M	M ₁	M ₂	EUR	Y4	NCG	H5G / -S / -Z	X5G-Z / -S	ESG 4	ESG 5	HDG 2	ZSG 4	ZSG mini	DSG 4	Verso	HSG	
125	125		40				45,5			173,00	80 878 530								●				

Čelusť, grip VS

- ▲ cena za kus
- ▲ VS = zväčšený upínací rozsah

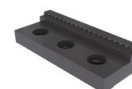
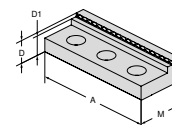

pre šírku zveráka	A	A ₁	D	D ₁	D ₂	E	M	M ₁	M ₂	EUR	Y4	NCG	H5G / -S / -Z	X5G-Z / -S	ESG 4	ESG 5	HDG 2	ZSG 4	ZSG mini	DSG 4	Verso	HSG	
125	125		22	17			45			99,30	80 892 245								●				

Čelusť, hladká VS, s povlakom WC

- ▲ širší upínací rozsah pre finálne obrábanie a 2. stranu
- ▲ WC = povlak wolframkarbidu
- ▲ cena za kus

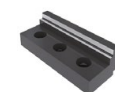
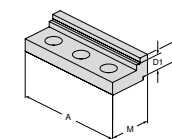

pre šírku zveráka	A	A ₁	D	D ₁	D ₂	E	M	M ₁	M ₂	EUR	Y4	NCG	H5G / -S / -Z	X5G-Z / -S	ESG 4	ESG 5	HDG 2	ZSG 4	ZSG mini	DSG 4	Verso	HSG	
125	125		19	14			45			239,00	80 892 240								●				

Hliníková čelusť, pohyblivá

- ▲ pre výrobu tvarových čelustí
- ▲ cena za kus

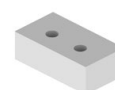
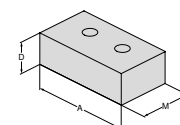

pre šírku zveráka	A	A ₁	D	D ₁	D ₂	E	M	M ₁	M ₂	EUR	Y4	NCG	H5G / -S / -Z	X5G-Z / -S	ESG 4	ESG 5	HDG 2	ZSG 4	ZSG mini	DSG 4	Verso	HSG	
80	80		28				48			86,40	80 878 850				●	●		●					
125	125		40				68			98,30	80 878 550				●	●		●					
160	160		50				85			124,00	80 878 305				●	●		●					

Prehľad systémových čelustí

Mäkká čelusť, oceľ, pohyblivá

- ▲ materiál: 16MnCr5
- ▲ pre výrobu tvarových čelustí
- ▲ cena za kus

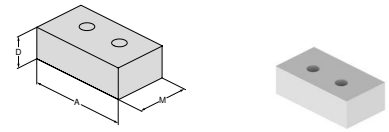

pre šírku zveráka	A	A ₁	D	D ₁	D ₂	E	M	M ₁	M ₂	EUR	Y4	NCG	H5G / -S / -Z	X5G-Z / -S	ESG 4	ESG 5	HDG 2	ZSG 4	ZSG mini	DSG 4	Verso	HSG	
80	80		28				48			89,10					●	●		●					
125	125		40				68			112,00					●	●		●					

Výkyvná doska, pohyblivá

- ▲ pre upínanie 6násobných otočných čelustí
- ▲ cena za kus
- ▲ vr. krycích skrutiek

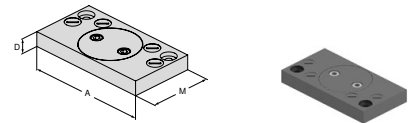

pre šírku zveráka	A	A ₁	D	D ₁	D ₂	E	M	M ₁	M ₂	EUR	Y4	NCG	H5G / -S / -Z	X5G-Z / -S	ESG 4	ESG 5	HDG 2	ZSG 4	ZSG mini	DSG 4	Verso	HSG	
80	125		19				76			409,00					●			●					
125	180		22				95			426,00					●			●					
160	256		22				170			726,00					●			●					

Adaptérová doska, pevná

- ▲ pre upínanie 6násobných otočných čelustí
- ▲ cena za kus
- ▲ vr. krycích skrutiek

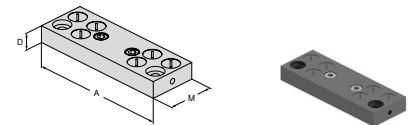

pre šírku zveráka	A	A ₁	D	D ₁	D ₂	E	M	M ₁	M ₂	EUR	Y4	NCG	H5G / -S / -Z	X5G-Z / -S	ESG 4	ESG 5	HDG 2	ZSG 4	ZSG mini	DSG 4	Verso	HSG	
80	125		19				39			290,00								●					
125	180		22				62			346,00								●					
160	256		22				125			484,00								●					

6násobná otočná čelusť

- ▲ 1 = hladká, s povlakom WC
- ▲ 2 = grip so stupňom 3 mm
- ▲ 3 = grip so stupňom 8 mm
- ▲ 4 = grip so stupňom 18 mm
- ▲ 5 = guľatý grip so stupňom 8 mm
- ▲ 6 = guľatý grip
- ▲ M_{max} = 60 Nm
- ▲ vr. upínacej skrutky
- ▲ cena za kus

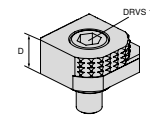

pre šírku zveráka	A	A ₁	D	D ₁	D ₂	E	M	M ₁	M ₂	EUR	Y4	NCG	H5G / -S / -Z	X5G-Z / -S	ESG 4	ESG 5	HDG 2	ZSG 4	ZSG mini	DSG 4	Verso	HSG	
			18							80,60			●	●	●			●			●	●	
													●	●	●			●			●	●	

Prehľad systémových čelustí

6násobná otočná čelusť, karbid grip

- ▲ 1 = hladká
- ▲ 2 = karbidový grip
- ▲ 3 = karbidový grip so stupňom 3 mm
- ▲ 4 = karbidový grip so stupňom 8 mm
- ▲ 5 = karbidový guľatý grip so stupňom 8 mm
- ▲ 6 = karbidový guľatý grip
- ▲ vr. upínacej skrutky
- ▲ cena za kus

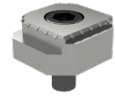
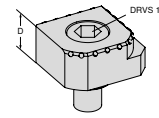

pre šírku zveráka	A	A ₁	D	D ₁	D ₂	E	M	M ₁	M ₂	EUR	Y4	NCG	H5G / -S / -Z	X5G-Z / -S	ESG 4	ESG 5	H5G 2	ZSG 4	ZSG mini	DSG 4	Verso	H5G	
			18							117,00	80 890 35300	●	●	●	●	●	●	●	●	●	●	●	●

6násobné systémové čeluste pre šírku 125 mm

Rozsah dodávky:

2 systémové čeluste s 2 párami priečných čelustí v T-drážke vr. upínacích skrutiek

ZSG
4

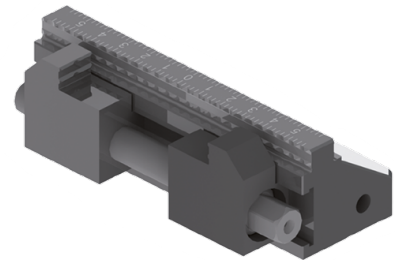
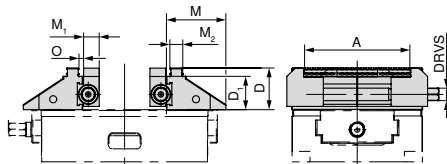

Pre šírku	A	D	D ₁	M	M ₁	M ₂	O	DRVS	WT	80 878 ...	
mm	mm	mm	mm	mm	mm	mm	mm	mm	kg	EUR	
125	37 - 101	40	32	57	15	12,4	3,3	12	3,8	Y4	
										1.720,00	525

ZSG mini



Osový zverák pre upínanie malých obrobkov

ZSG mini v mechanickom prevedení s vysokou upínacou silou a rýchlovýmennými čeľustami. Ideálna voľba pre obrábanie surových i hotových dielov, viacnásobné a automatické upínanie.

Výhody pre Vás:

- ▲ rýchla výmena čeľustí bez použitia náradia
- ▲ kompaktnosť a precíznosť
- ▲ optimálny prístup zo všetkých strán
- ▲ šírku čeľustí je možné zmeniť (45 mm a 70 mm)
- ▲ vysoká upínacia sila a veľký upínací rozsah
- ▲ upínací systém pre automatizáciu
- ▲ nehrdzavejúce a kalené základné teleso



Upnutie / Vyrovnávanie:



Upnutie pomocou 2 skrutiek M6 zhora cez základné teleso.



Upnutie pomocou 2 skrutiek M6 zhora cez základné teleso. Vyrovnávanie je možné vykonať pomocou precíznych otvorov s $\varnothing 12^{H7}$.



Obidve varianty sú vybavené upínacími otvormi pre upínací systém s nulovým bodom LANG Quick Point 52 x 52.

Upínacia sila:

Uťahovací moment / Upínacia sila ZSG mini

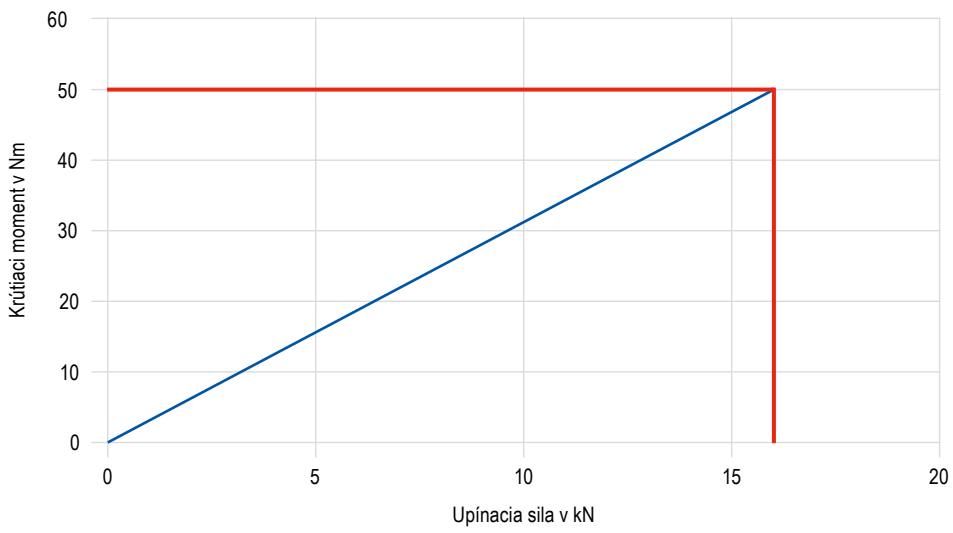

CentriClamp – ZSG mini

- ▲ osový zverák pre upínanie malých obrobkov
- ▲ bez systémových čelustí
- ▲ rýchla výmena čelustí bez použitia náradia
- ▲ kompaktnosť a precíznosť
- ▲ optimálny prístup zo všetkých strán Optimálna prístupnosť zo všetkých strán
- ▲ vymeniteľné čeluste v 2 šírkach (45 mm a 70 mm)
- ▲ nehrdzavejúce a kalené základné teleso

Rozsah dodávky:

Základné teleso zveráka ZSG mini s vretenom

ZSG
mini

MNG
mini

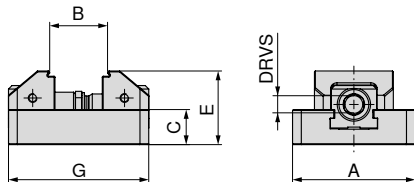

NEW

80 912 ...

EUR

Y4

420,00 07000

476,00 07100

A	B	C	E	G	MXC	DRVS	WT
mm	mm	mm	mm	mm	kN	mm	kg
70	7 - 57	20	42	80	16	11	0,9
70	7 - 77	20	42	100	16	11	1,1

Prehľad zverákov

Rozmery spodnej strany	94	Rozmerové tabuľky pre rôzne čeluste	95-97
Systémové príslušenstvo	98-100	Upínací systém s nulovým bodom MNG/PNG	134-163
Obecné príslušenstvo	164-183		

Rozmery spodnej strany zveráka ZSG mini

Šírka základného telesa 70 mm

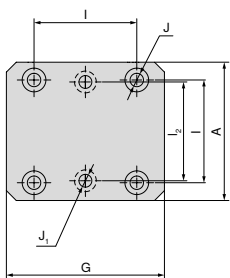

A	J ₁	J _{H7}	l ₂ ±0,01	l ±0,01	G
mm	mm	mm	mm	mm	mm
70	6,5	12	50	52	80
70	6,5	12	50	52	100

ZSG mini – tabuľka montážnych rozmerov pre rôzne čeluste

S rýchlovýmennou čelustou, grip 3 mm

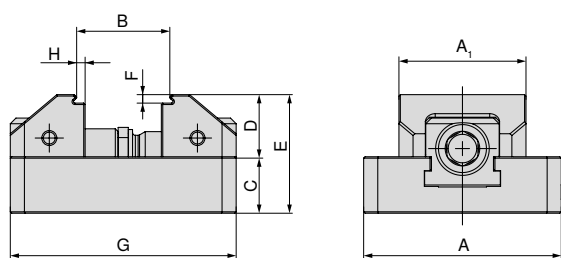

A mm	A ₁ mm	B mm	C mm	D mm	E mm	F mm	G mm	H mm	Artikel č. Systémové čeluste
70	45	7 - 33	20	22	42	3	80	3	2 x 80 912 30100
70	70	7 - 33	20	22	42	3	80	3	2 x 80 912 30200
70	45	7 - 53	20	22	42	3	100	3	2 x 80 912 30100
70	70	7 - 53	20	22	42	3	100	3	2 x 80 912 30200

S rýchlovýmennou čelustou, hladký stupeň 5 mm

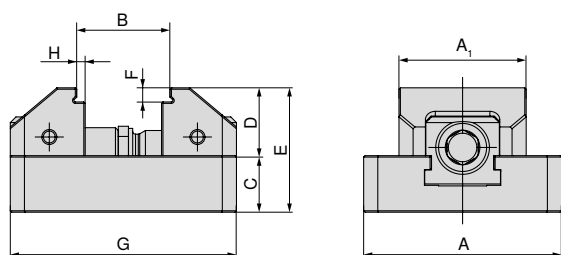

A mm	A ₁ mm	B mm	C mm	D mm	E mm	F mm	G mm	H mm	Artikel č. Systémové čeluste
70	45	7 - 33	20	24	44	5	80	3	2 x 80 912 30300
70	70	7 - 33	20	24	44	5	80	3	2 x 80 912 30400
70	45	7 - 53	20	24	44	5	100	3	2 x 80 912 30300
70	70	7 - 53	20	24	44	5	100	3	2 x 80 912 30400

S rýchlovýmennou čelustou, mäkká, oceľ

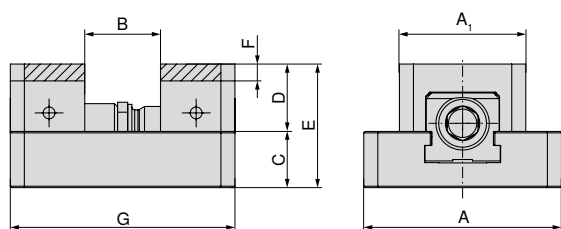

A mm	A ₁ mm	B mm	C mm	D mm	E mm	F mm	G mm	Artikel č. Systémové čeluste
70	45	0 - 26	20	24	44	6	80	2 x 80 912 31000
70	70	0 - 26	20	24	44	6	80	2 x 80 912 31100
70	45	0 - 46	20	24	44	6	80	2 x 80 912 31000
70	70	0 - 46	20	24	44	6	80	2 x 80 912 31100

ZSG mini – tabuľka montážnych rozmerov pre rôzne čeluste

S rýchlovýmennou čelustou, s vyrazením

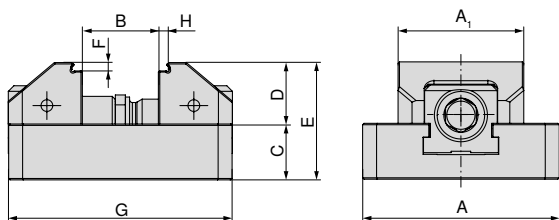

A mm	A ₁ mm	B mm	C mm	D mm	E mm	F mm	G mm	H mm	Artikel č. Systémové čeluste
70	45	7 - 32	20	22	44	3	80	3	2 x 80 912 31200
70	70	7 - 32	20	22	44	3	80	3	2 x 80 912 31300
70	45	7 - 52	20	22	44	3	100	3	2 x 80 912 31200
70	70	7 - 52	20	22	44	3	100	3	2 x 80 912 31300

S rýchlovýmennou čelustou, s vyrazením, VS

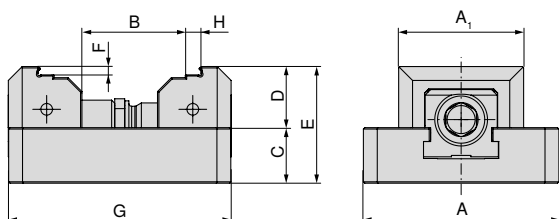

A mm	A ₁ mm	B mm	C mm	D mm	E mm	F mm	G mm	H mm	Artikel č. Systémové čeluste
70	45	31 - 56	20	22	44	3	80	5	2 x 80 912 31400
70	70	31 - 56	20	22	44	3	80	5	2 x 80 912 31500
70	45	31 - 76	20	22	44	3	100	5	2 x 80 912 31400
70	70	31 - 76	20	22	44	3	100	5	2 x 80 912 31500

ZSG mini – tabuľka montážnych rozmerov pre rôzne čeluste

S rýchlovýmennou čelustou VS, grip 3 mm

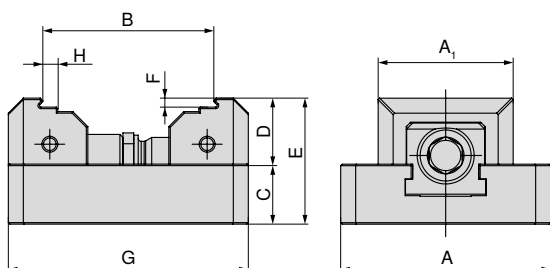

A mm	A ₁ mm	B mm	C mm	D mm	E mm	F mm	G mm	H mm	Artikel č. Systémové čeluste
70	45	31 - 57	20	22	42	3	80	5	2 x 80 912 30500
70	70	31 - 57	20	22	42	3	80	5	2 x 80 912 30600
70	45	31 - 77	20	22	42	3	100	5	2 x 80 912 30500
70	70	31 - 77	20	22	42	3	100	5	2 x 80 912 30600

S rýchlovýmennou čelustou, VS, hladká 5 mm

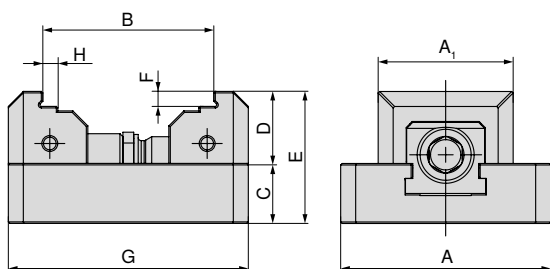

A mm	A ₁ mm	B mm	C mm	D mm	E mm	F mm	G mm	H mm	Artikel č. Systémové čeluste
70	45	31 - 56	20	24	44	5	80	5	2 x 80 912 30700
70	70	31 - 56	20	24	44	5	80	5	2 x 80 912 30800
70	45	31 - 76	20	24	44	5	100	5	2 x 80 912 30700
70	70	31 - 76	20	24	44	5	100	5	2 x 80 912 30800

Prehľad systémových čelustí

Rýchlovýmenná čelusť, grip 3 mm

▲ cena za kus

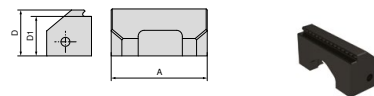

pre šírku zveráka	A	A ₁	D	D ₁	D ₂	E	M	M ₁	M ₂	EUR	Y4	NCG	H5G / -S / -Z	X5G-Z / -S	ESG 4	ESG 5	HDG 2	ZSG 4	ZSG mini	DSG 4	Verso	HSG		
70	45		22	19						50,80	80 912 30100									●				
70	70		22	19						66,90	80 912 30200									●				

Rýchlovýmenná čelusť, hladký stupeň 5 mm

▲ cena za kus

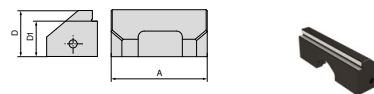

pre šírku zveráka	A	A ₁	D	D ₁	D ₂	E	M	M ₁	M ₂	EUR	Y4	NCG	H5G / -S / -Z	X5G-Z / -S	ESG 4	ESG 5	HDG 2	ZSG 4	ZSG mini	DSG 4	Verso	HSG		
70	45		24	19						61,50	80 912 30300									●				
70	70		24	19						77,80	80 912 30400									●				

Rýchlovýmenná čelusť, VS, grip 3 mm

▲ cena za kus

▲ VS = zväčšený upínací rozsah

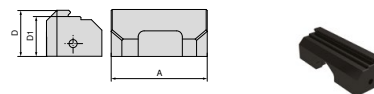

pre šírku zveráka	A	A ₁	D	D ₁	D ₂	E	M	M ₁	M ₂	EUR	Y4	NCG	H5G / -S / -Z	X5G-Z / -S	ESG 4	ESG 5	HDG 2	ZSG 4	ZSG mini	DSG 4	Verso	HSG		
70	45		22	19						50,80	80 912 30500									●				
70	70		22	19						66,90	80 912 30600									●				

Rýchlovýmenná čelusť VS, hladká 5 mm

▲ cena za kus

▲ VS = zväčšený upínací rozsah

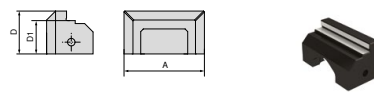

pre šírku zveráka	A	A ₁	D	D ₁	D ₂	E	M	M ₁	M ₂	EUR	Y4	NCG	H5G / -S / -Z	X5G-Z / -S	ESG 4	ESG 5	HDG 2	ZSG 4	ZSG mini	DSG 4	Verso	HSG		
70	45		24	19						61,50	80 912 30700									●				
70	70		24	19						77,80	80 912 30800									●				

Prehľad systémových čelustí

Rýchlovýmenná čelusť, mäkká, oceľ

- ▲ materiál: 15NiCr13
- ▲ cena za kus

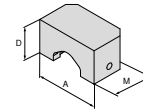

pre šírku zveráka	A	A ₁	D	D ₁	D ₂	E	M	M ₁	M ₂	EUR	Y4	NCG	H5G / -S / -Z	X5G-Z / -S	ESG 4	ESG 5	HDG 2	ZSG 4	ZSG mini	DSG 4	Verso	HSG	
70	45		24				26,5			41,00										●			
70	70		24				26,5			41,00										●			

Rýchlovýmenná čelusť, grip so stupnicou

- ▲ zhodné s profilom LANG
- ▲ cena za kus

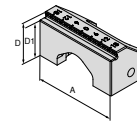

pre šírku zveráka	A	A ₁	D	D ₁	D ₂	E	M	M ₁	M ₂	EUR	Y4	NCG	H5G / -S / -Z	X5G-Z / -S	ESG 4	ESG 5	HDG 2	ZSG 4	ZSG mini	DSG 4	Verso	HSG	
70	45		22	19						77,80										●			
70	70		22	19						77,80										●			

Rýchlovýmenná čelusť, grip 3 mm so stupnicou, VS

- ▲ cena za kus
- ▲ zhodné s profilom LANG
- ▲ VS = zväčšený upínací rozsah

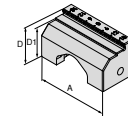

pre šírku zveráka	A	A ₁	D	D ₁	D ₂	E	M	M ₁	M ₂	EUR	Y4	NCG	H5G / -S / -Z	X5G-Z / -S	ESG 4	ESG 5	HDG 2	ZSG 4	ZSG mini	DSG 4	Verso	HSG	
70	45		22	19						95,00										●			
70	70		22	19						95,00										●			

Prehad systemoveho prisluenstva

Orech

▲ vhodny pre tvorhran 3/8"

ESG 4	ZSG 4
ZSG mini	DSG 4
MSG 2	



tvorhran	DRVS mm	80 875 ...
3/8"	11	EUR Y4 18,20 11100



→ Strana 176+180

Prehad magnetickych podloiek pod obrobok, vhodny magneticky doraz obrobku a momentovy klu (artikel . 80 892 23800 a 80 884 402).

Valcov skrutka s vnutornm esthranom

▲ cena za kus

ZSG mini



G	80 912 ...
M6x25	EUR Y4 1,20 50100

Valcov kolk

▲ cena za kus

ZSG mini



D ₁ m6 mm	M mm	80 912 ...
12	18	EUR Y4 2,30 50200

DSG 4

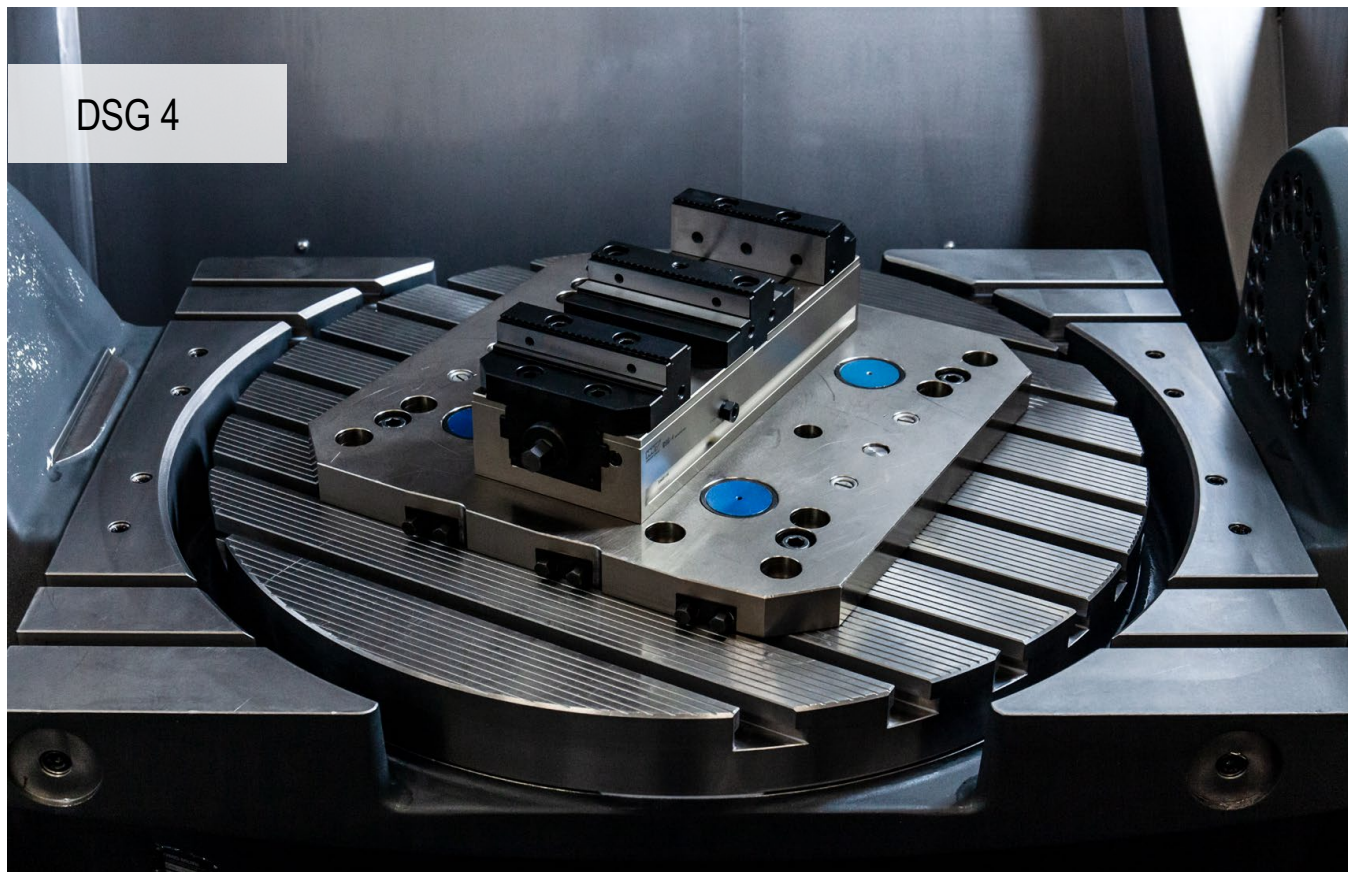

Vysoká presnosť a vysoká účinnosť

Užívateľsky prívetivý upínací systém DSG 4 garantuje trvale vysokú presnosť a široké spektrum použitia.

Výhody pre Vás:

- ▲ jednoduchá a vysoko výkonná funkcia tretej ruky
- ▲ jednoduché a rýchle polohovanie na upínacom systéme s nulovým bodom MNG
- ▲ vysoké upínacie sily medzi 5 – 40 kN s nízkym ťahovacím momentom
- ▲ jednoduchá a rýchla výmena čeľustí pomocou 2 skrutiek
- ▲ široká paleta čeľustí a príslušenstva

Upnutie / Vyrovnávanie:



Pripevnenie pomocou upínacieho systému s nulovým bodom MNG (2-3 upínacie čapy).



Pripevnenie cez základné teleso pomocou štyroch skrutiek M8.



Pripevnenie cez základné teleso pomocou dvoch lícovaných skrutiek **Artikel č. 80 895 019**.



Pripevnenie pomocou 4-6 úpiniek **Artikel č. 80 890 315**.

Upínacia sila:

Uťahovací moment / upínacia sila DSG 4 – 80 mm

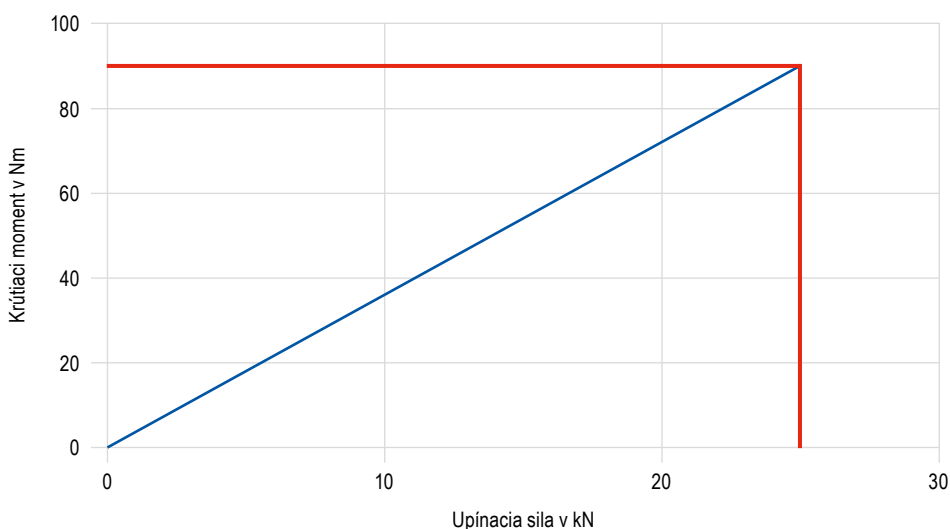

Uťahovací moment / upínacia sila DSG 4 – 125 mm

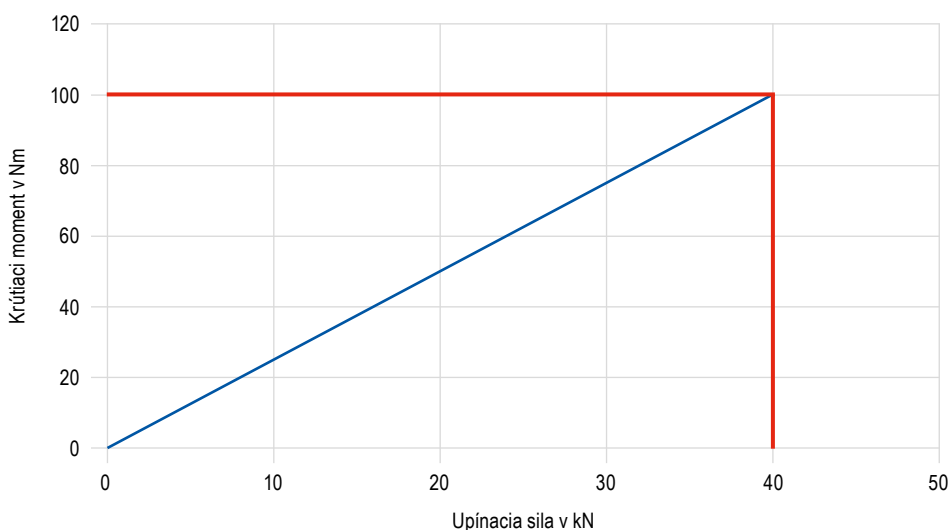

Funkcia tretej ruky

Funkcia tretej ruky u zveráka DSG 4 je zaistená predpätím zadného posúvača prostredníctvom tlačných pružín.



Bočná upínacia skrutka A nie je pevne dotiahnutá, ale povolená o cca 1/2 otáčky. V prípade maximálne otvoreného zveráka sa musia pohyblivé upínacie čeluste B a C umiestniť a pripevniť do vhodných drážok posúvača D a E, a to v závislosti od veľkosti obrábku. Upínať je možné i dva rôzne veľké obrábky.

Prestavba na jednoduchý zverák



Pomocou stavacej skrutky s vnútorným šesťhranom sa zadný posúvač zablokuje a zverák DSG 4 je možné potom používať i ako jednoduchý zverák. **Dôležité upozornenie:** Nevhodné, keď chcete používať niekoľko takto upravených zverákov vedľa seba. V takomto prípade odporúčame upraviť základné teleso – vyfrézovať dodatočnú priečnu drážku a použiť vhodnú pevnú čelusť.

PolyClamp – DSG 4

- ▲ dvojitý zverák bez systémových čelustí
- ▲ 100 % zapuzdrenie
- ▲ rýchla demontáž a montáž
- ▲ flexibilný upínací systém

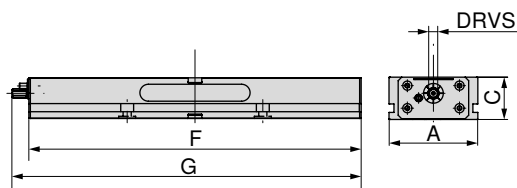

								80 906 ...	
								EUR	
A	C	F	G	TQX	DRVS	MXC	WT	Y4	
mm	mm	mm	mm	Nm	mm	kN	kg		
80	55	300	308	90	12	0 - 25	8	1.560,00	080
125	60	320	347	100	14	0 - 40	14	1.850,00	125
125	60	390	417	100	14	0 - 40	17	2.040,00	12700
125	60	460	487	100	14	0 - 40	20	2.300,00	12800
125	60	530	557	100	14	0 - 40	24	2.510,00	12900
125	60	600	627	100	14	0 - 40	27	2.720,00	13000
125	60	670	697	100	14	0 - 40	30	2.840,00	13100
125	60	740	767	100	14	0 - 40	34	2.950,00	126

Prehľad zverákov

Rozmerové tabuľky pre rôzne čeluste	105–107	Systémové príslušenstvo	108+110
Funkcia tretej ruky	102	Prestavba na jednoduchý zverák	103
Upínací systém s nulovým bodom MNG/PNG	134–163	Obecné príslušenstvo	164–183

Rozmery spodnej strany DSG 4

Šírka základného telesa 80 mm,
dĺžka 300 mm

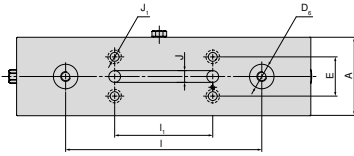

A	D ₆ H ₆	E ±0,015	I ±0,01	I ₁ ±0,01	J H ₇	J ₁
mm	mm	mm	mm	mm	mm	mm
80	25	40	200	100	12	9

Šírka základného telesa 125 mm,
dĺžka 460 mm, 530 mm

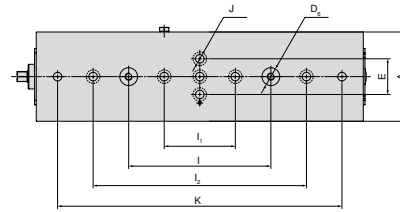

A	D ₆ H ₆	E ±0,015	I ±0,01	I ₁ ±0,01	I ₂ ±0,002	J H ₇	K ±0,002
mm	mm	mm	mm	mm	mm	mm	mm
125	25	50	200	100	300	12	400
125	25	50	200	100	300	12	500

Šírka základného telesa 125 mm,
dĺžka 320 mm

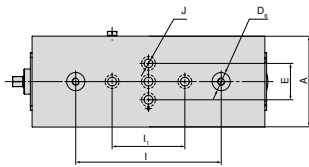

A	D ₆ H ₆	E ±0,015	I ±0,01	I ₁ ±0,01	J H ₇
mm	mm	mm	mm	mm	mm
125	25	50	200	100	12

Šírka základného telesa 125 mm,
dĺžka 600 mm

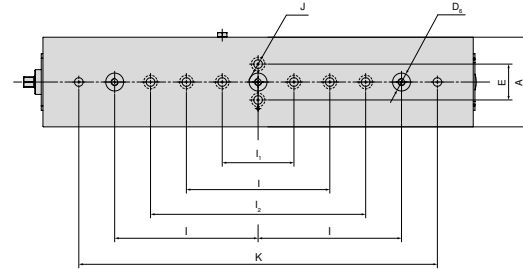

A	D ₆ H ₆	E ±0,015	I ±0,01	I ₁ ±0,01	I ₂ ±0,002	J H ₇	K ±0,002
mm	mm	mm	mm	mm	mm	mm	mm
125	25	50	200	100	300	12	500

Šírka základného telesa 125 mm,
dĺžka 390 mm

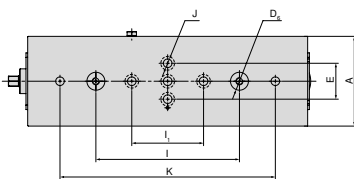

A	D ₆ H ₆	E ±0,015	I ±0,01	I ₁ ±0,01	J H ₇	K ±0,002
mm	mm	mm	mm	mm	mm	mm
125	25	50	200	100	12	300

Šírka základného telesa 125 mm,
dĺžka 670 mm, 740 mm

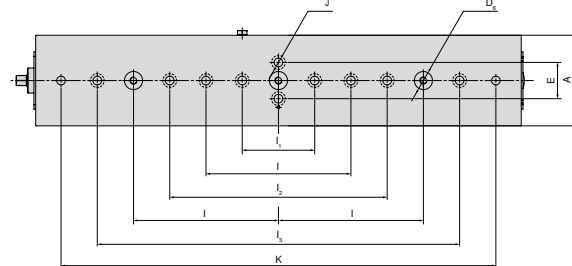

A	D ₆ H ₆	E ±0,015	I ±0,01	I ₁ ±0,01	I ₂ ±0,002	I ₃ ±0,025	J H ₇	K ±0,002
mm	mm	mm	mm	mm	mm	mm	mm	mm
125	25	50	200	100	300	500	12	600
125	25	50	200	100	300	500	12	700

DSG 4 rozmerová tabuľka pre rôzne čeluste

S otočnými čelustami grip a stredovou čelustou grip

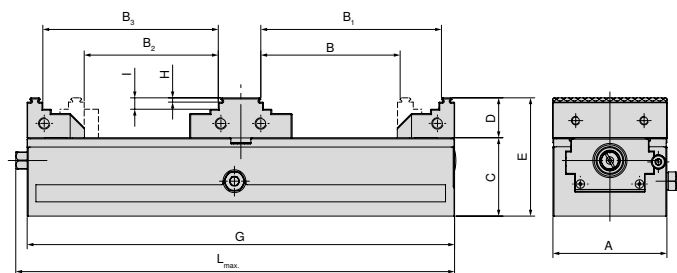

A mm	B mm	B ₁ mm	B ₂ mm	B ₃ mm	C mm	D mm	E mm	G mm	H mm	I mm	L _{max} mm	Artikel č. Systémové čeluste
80	25 - 97	54 - 126	31 - 93	51 - 122	55	28	83	300	3	8	308	2 x 80 878 810 + 80 906 300
125	40 - 86	75 - 121	42 - 79	68 - 114	60	40	100	320	3	18	347	2 x 80 901 303 + 80 906 304
125	40 - 121	75 - 156	42 - 114	68 - 149	60	40	100	390	3	18	417	2 x 80 901 303 + 80 906 304
125	40 - 156	75 - 191	42 - 149	68 - 184	60	40	100	460	3	18	487	2 x 80 901 303 + 80 906 304
125	40 - 191	75 - 226	42 - 184	68 - 219	60	40	100	530	3	18	557	2 x 80 901 303 + 80 906 304
125	40 - 226	75 - 261	42 - 219	68 - 254	60	40	100	600	3	18	627	2 x 80 901 303 + 80 906 304
125	40 - 261	75 - 296	42 - 254	68 - 289	60	40	100	670	3	18	697	2 x 80 901 303 + 80 906 304
125	40 - 296	75 - 331	42 - 289	68 - 324	60	40	100	740	3	18	767	2 x 80 901 303 + 80 906 304

S otočnými čelustami grip a hladkou stredovou čelustou

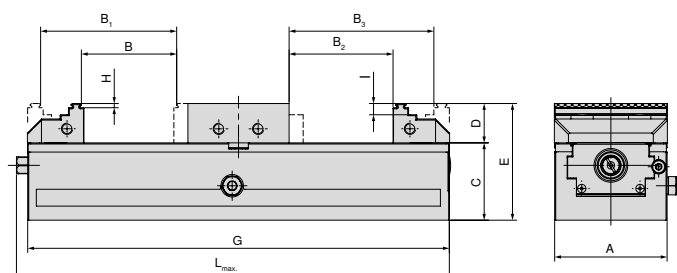

A mm	B mm	B ₁ mm	B ₂ mm	B ₃ mm	C mm	D mm	E mm	G mm	H mm	I mm	L _{max} mm	Artikel č. Systémové čeluste
80	5 - 67	34 - 96	0 - 73	40 - 102	55	28	83	300	3	8	308	2 x 80 878 810 + 80 906 301
125	7 - 44	42 - 77	0 - 47	46 - 82	60	40	100	320	3	18	347	2 x 80 901 303 + 80 906 305
125	7 - 79	42 - 112	0 - 82	46 - 117	60	40	100	390	3	18	417	2 x 80 901 303 + 80 906 305
125	7 - 114	42 - 149	0 - 117	46 - 152	60	40	100	460	3	18	487	2 x 80 901 303 + 80 906 305
125	7 - 147	42 - 182	0 - 152	46 - 187	60	40	100	530	3	18	557	2 x 80 901 303 + 80 906 305
125	7 - 184	42 - 217	0 - 187	46 - 222	60	40	100	600	3	18	627	2 x 80 901 303 + 80 906 305
125	7 - 219	42 - 252	0 - 222	46 - 257	60	40	100	670	3	18	697	2 x 80 901 303 + 80 906 305
125	7 - 254	42 - 287	0 - 257	46 - 292	60	40	100	740	3	18	767	2 x 80 901 303 + 80 906 305

DSG 4 rozmerová tabuľka pre rôzne čeluste

S blokovými čelustami a hladkou stredovou čelustou

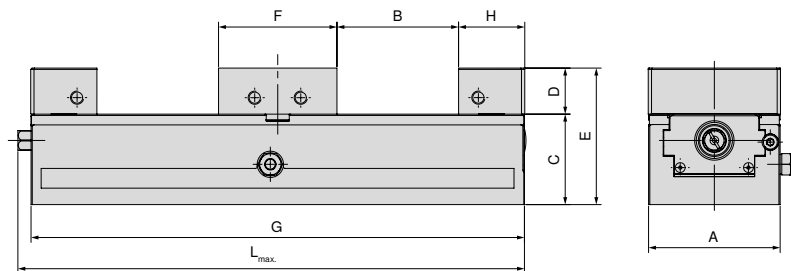

A mm	B mm	C mm	D mm	E mm	F mm	G mm	H mm	L _{max.} mm	Artikel č. Systémové čeluste
80	0 - 73	55	28	83	72	300	40	308	2 x 80 901 31300 + 80 906 301
125	0 - 46	60	40	100	98	320	66	347	2 x 80 901 31500 + 80 906 305
125	0 - 81	60	40	100	98	390	66	417	2 x 80 901 31500 + 80 906 305
125	0 - 116	60	40	100	98	460	66	487	2 x 80 901 31500 + 80 906 305
125	0 - 151	60	40	100	98	530	66	557	2 x 80 901 31500 + 80 906 305
125	0 - 186	60	40	100	98	600	66	627	2 x 80 901 31500 + 80 906 305
125	0 - 221	60	40	100	98	670	66	697	2 x 80 901 31500 + 80 906 305
125	0 - 256	60	40	100	98	740	66	767	2 x 80 901 31500 + 80 906 305

S výkyvnou a adaptérovou čelustou

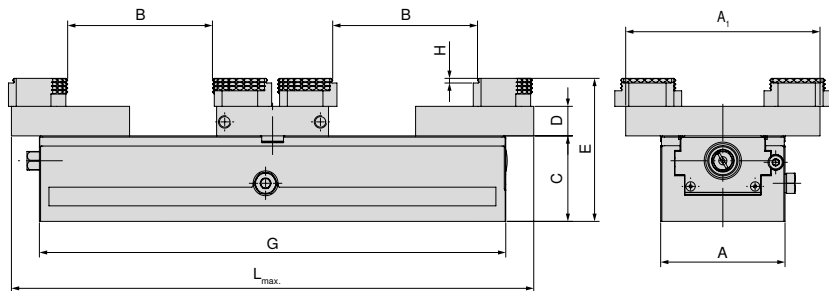

A mm	A ₁ mm	B mm	C mm	D mm	E mm	G mm	H mm	L _{max.} mm	Artikel č. Systémové čeluste
80	125	0 - 92	55	19	92	300	3	308	2 x 80 878 870 + 80 906 303
125	180	7 - 92	60	22	100	320	3	365	2 x 80 878 570 + 80 906 307
125	180	7 - 133	60	22	100	390	3	435	2 x 80 878 570 + 80 906 307
125	180	7 - 168	60	22	100	460	3	505	2 x 80 878 570 + 80 906 307
125	180	7 - 203	60	22	100	530	3	575	2 x 80 878 570 + 80 906 307
125	180	7 - 238	60	22	100	600	3	645	2 x 80 878 570 + 80 906 307
125	180	7 - 273	60	22	100	670	3	715	2 x 80 878 570 + 80 906 307
125	180	7 - 308	60	22	100	740	3	785	2 x 80 878 570 + 80 906 307

DSG 4 rozmerová tabuľka pre rôzne čeluste

S hliníkovými čelustami a hliníkovou stredovou čelustou

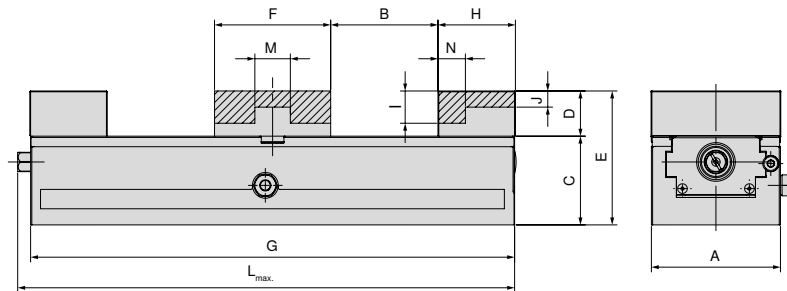

A mm	B mm	C mm	D mm	E mm	F mm	G mm	H mm	I mm	J mm	L _{max} mm	M mm	N mm	Artikel č. Systémové čeluste
80	0 - 66	55	28	83	72	300	40	20	10	308	22	17	2 x 80 878 850 + 80 906 302
125	0 - 42	60	40	100	98	320	68		17	347	38	28	2 x 80 878 550 + 80 906 306
125	0 - 77	60	40	100	98	390	68		17	417	38	28	2 x 80 878 550 + 80 906 306
125	0 - 112	60	40	100	98	460	68		17	487	38	28	2 x 80 878 550 + 80 906 306
125	0 - 147	60	40	100	98	530	68		17	557	38	28	2 x 80 878 550 + 80 906 306
125	0 - 182	60	40	100	98	600	68		17	627	38	28	2 x 80 878 550 + 80 906 306
125	0 - 217	60	40	100	98	670	68		17	697	38	28	2 x 80 878 550 + 80 906 306
125	0 - 252	60	40	100	98	740	68		17	767	38	28	2 x 80 878 550 + 80 906 306

Prehľad systémových čelustí

Otočná čelusť, grip 3 mm, pohyblivá

▲ cena za kus

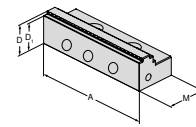

pre šírku zveráka	A	A ₁	D	D ₁	D ₂	E	M	M ₁	M ₂	EUR	Y4	NCG	H5G / -S / -Z	X5G-Z / -S	ESG 4	ESG 5	HDG 2	ZSG 4	ZSG mini	DSG 4	Verso	HSG				
125	125		40	37			66			224,00					●	●				●						

Otočná čelusť, grip 3 mm, pohyblivá

▲ cena za kus

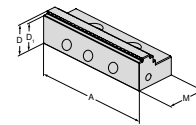

pre šírku zveráka	A	A ₁	D	D ₁	D ₂	E	M	M ₁	M ₂	EUR	Y4	NCG	H5G / -S / -Z	X5G-Z / -S	ESG 4	ESG 5	HDG 2	ZSG 4	ZSG mini	DSG 4	Verso	HSG				
80	80		28	25			40			135,00					●	●		●		●						

Stredová čelusť, grip 3 mm

▲ cena za kus

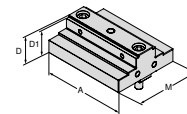

pre šírku zveráka	A	A ₁	D	D ₁	D ₂	E	M	M ₁	M ₂	EUR	Y4	NCG	H5G / -S / -Z	X5G-Z / -S	ESG 4	ESG 5	HDG 2	ZSG 4	ZSG mini	DSG 4	Verso	HSG				
80	80		28	25			72			278,00											●					
125	125		40	37			98			370,00											●					

Stredová čelusť, hladká

▲ cena za kus

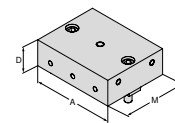

pre šírku zveráka	A	A ₁	D	D ₁	D ₂	E	M	M ₁	M ₂	EUR	Y4	NCG	H5G / -S / -Z	X5G-Z / -S	ESG 4	ESG 5	HDG 2	ZSG 4	ZSG mini	DSG 4	Verso	HSG			
80	80		28				72			214,00											●				
125	125		40				98			317,00											●				

Prehľad systémových čelustí

Hliníková čelusť, pohyblivá

- ▲ pre výrobu tvarových čelustí
- ▲ cena za kus

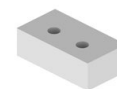
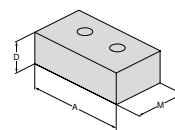

pre šírku zveráka	A	A ₁	D	D ₁	D ₂	E	M	M ₁	M ₂	EUR	Y4	NCG	H5G / -S / -Z	X5G-Z / -S	ESG 4	ESG 5	HDG 2	ZSG 4	ZSG mini	DSG 4	Verso	HSG	
80	80		28				48			86,40	80 878 850				●	●		●		●			
125	125		40				68			98,30	80 878 550				●						●		

Hliníková stredová čelusť

- ▲ pre výrobu tvarových čelustí
- ▲ cena za kus

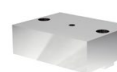
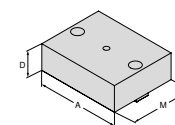

pre šírku zveráka	A	A ₁	D	D ₁	D ₂	E	M	M ₁	M ₂	EUR	Y4	NCG	H5G / -S / -Z	X5G-Z / -S	ESG 4	ESG 5	HDG 2	ZSG 4	ZSG mini	DSG 4	Verso	HSG	
80	80		28				72			77,80	80 906 302										●		
125	125		40				98			105,00	80 906 306										●		

Bloková čelusť, pohyblivá

- ▲ cena za kus

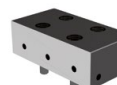
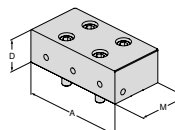

pre šírku zveráka	A	A ₁	D	D ₁	D ₂	E	M	M ₁	M ₂	EUR	Y4	NCG	H5G / -S / -Z	X5G-Z / -S	ESG 4	ESG 5	HDG 2	ZSG 4	ZSG mini	DSG 4	Verso	HSG	
80	80		28				40			244,00	80 901 31300				●	●		●		●			
125	125		40				66			342,00	80 901 31500				●						●		

Výkyvná doska, pohyblivá

- ▲ pre upínanie 6násobných otočných čelustí
- ▲ cena za kus
- ▲ vr. krycích skrutiek

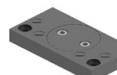
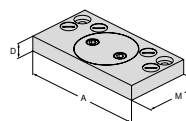

pre šírku zveráka	A	A ₁	D	D ₁	D ₂	E	M	M ₁	M ₂	EUR	Y4	NCG	H5G / -S / -Z	X5G-Z / -S	ESG 4	ESG 5	HDG 2	ZSG 4	ZSG mini	DSG 4	Verso	HSG	
80	125		19				76			409,00	80 878 870				●								
125	180		22				95			426,00	80 878 570				●			●		●			

Prehľad systémových čelustí

Stredová adaptérová doska, pevná

- ▲ pre upínanie 6násobných otočných čelustí
- ▲ cena za kus
- ▲ vr. krycích skrutiek

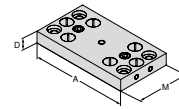

pre šírku zveráka	A	A ₁	D	D ₁	D ₂	E	M	M ₁	M ₂	EUR	Y4	NCG	H5G / -S / -Z	X5G-Z / -S	ESG 4	ESG 5	HDG 2	ZSG 4	ZSG mini	DSG 4	Verso	HSG	
80	125		19				72			291,00													
125	180		22				98			346,00											●		

6násobná otočná čelusť

- ▲ 1 = hladká, s povlakom WC
- ▲ 2 = grip so stupňom 3 mm
- ▲ 3 = grip so stupňom 8 mm
- ▲ 4 = grip so stupňom 18 mm
- ▲ 5 = guľatý grip so stupňom 8 mm
- ▲ 6 = guľatý grip
- ▲ M_{max} = 60 Nm
- ▲ vr. upínacej skrutky
- ▲ cena za kus

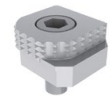
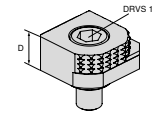

pre šírku zveráka	A	A ₁	D	D ₁	D ₂	E	M	M ₁	M ₂	EUR	Y4	NCG	H5G / -S / -Z	X5G-Z / -S	ESG 4	ESG 5	HDG 2	ZSG 4	ZSG mini	DSG 4	Verso	HSG	
			18							80,60			●	●	●				●		●	●	

6násobná otočná čelusť, karbid grip

- ▲ 1 = hladká
- ▲ 2 = karbidový grip
- ▲ 3 = karbidový grip so stupňom 3 mm
- ▲ 4 = karbidový grip so stupňom 8 mm
- ▲ 5 = karbidový guľatý grip so stupňom 8 mm
- ▲ 6 = karbidový guľatý grip
- ▲ vr. upínacej skrutky
- ▲ cena za kus

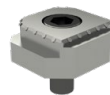
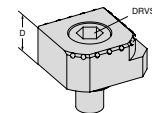

pre šírku zveráka	A	A ₁	D	D ₁	D ₂	E	M	M ₁	M ₂	EUR	Y4	NCG	H5G / -S / -Z	X5G-Z / -S	ESG 4	ESG 5	HDG 2	ZSG 4	ZSG mini	DSG 4	Verso	HSG	
			18							117,00			●	●	●				●		●	●	

Prehľad systémového príslušenstva

Plastová záslepka

DSG
4



G
M10x12

80 906 ...
EUR
Y4
1,20 500

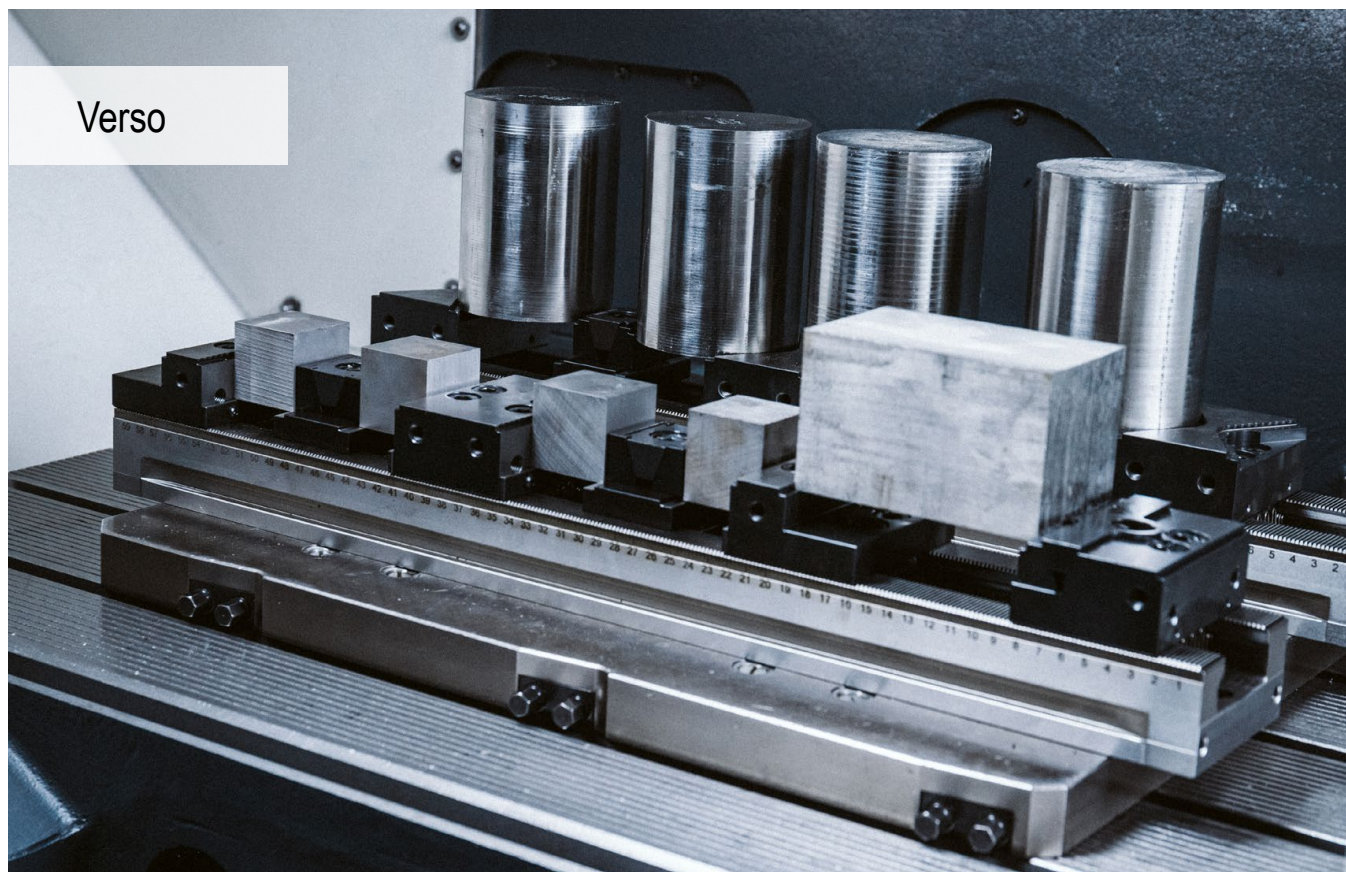

Univerzálny zverák pre upínanie obrobkov

Pomocou nového viacnásobného zveráka je možné na 3osovom, 4osovom i 5osovom stroji skvele upínať viac malých i veľkých obrobkov. Vďaka štíhlejšiemu prevedeniu čelustí sa zväčšilo množstvo upínaných obrobkov.

Výhody pre Vás:

- ▲ kalené a brúsené ozubenie garantuje maximálnu precíznosť a tvarovú stálosť
- ▲ systém rýchlej výmeny čelustí ako pevných, tak staviteľných čelustí
- ▲ kompletný stavebnicový systém pre všetky druhy obrábacích centier
- ▲ viacnásobné upínanie pomocou klinových upínacích čelustí
- ▲ rozsiahla ponuka čelustí pre stavebnicový upínací systém
- ▲ jednoduché predĺženie upínacej lišty pomocou spojovacieho kusu



Upnutie / Vyrovnávanie:



Pomocou T-drážok alebo skrutiek:
Vyrovnávanie v T-drážke (14, 16, 18 mm)
pomocou vhodnej polohovacej súpravy
pre T-drážky. Pre T-drážku 12 mm:
použite 2 valcové kolíky, Ø 12.



S úpinkami:
Polohovacia súprava a upínanie
s bočne umiestnenými úpinkami.



Cez rastrové otvory:
Polohovanie a upínanie pomocou dvoch lícovaných
skrutiek Ø12f7 / M12, v prvom a poslednom otvore
upínacej lišty. Dodatočné upnutie pomocou valcových
skrutiek M12 cez zvyšné otvory.

Upnutie / Vyrovnávanie:



S upínacím systémom s nulovým bodom:

Na upínacej lište sú umiestnené rozhrania MNG,

ktoré umožňujú montáž upínacích čapov MNG,

(až do dĺžky základného telesa 500 mm = 2 upínacie čapy, popr. od 600 mm = 3 upínacie čapy).

Upínacia sila:

Uťahovací moment / upínacia sila Verso

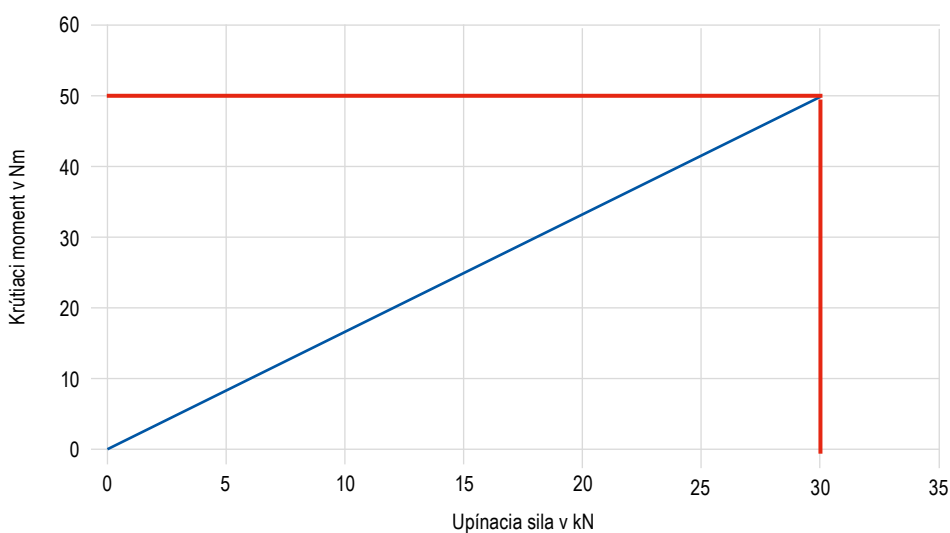

Rýchla výmena čelustí pre pevné a prestaviteľné čeluste

Viacnásobné zveráky Verso sú štandardne vybavené systémom rýchlej výmeny čelustí. Pomocou dvoch skrutiek je možné povoliť, odobrať či upraviť pevnú i prestaviteľnú čelusť. Čelusť sa vyťahuje smerom hore. Týmto spôsobom je možné odstrániť akúkoľvek jednotlivú čelusť, bez toho aby sa musela demontovať ďalšia čelusť. Tým sa podstatne skráti prípravné časy.

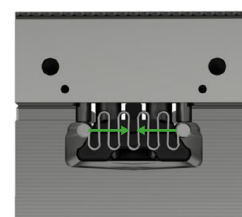

Povolenie

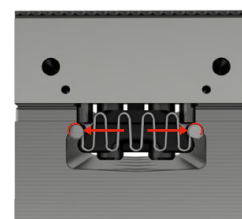

Upnutie



Povoliť skrutky



Vytriahnuť a vložiť



Dotiahnuť skrutky

System rýchlej výmeny upínacích čelustí

Pevné a prestaviteľné čeluste systému viacnásobného upínania Verso sú štandardne vybavené systémom rýchlej výmeny čelustí. Pomocou dvoch skrutiek je možné povoliť upínaciu čelusť a nasledovne ju môžete vymeniť. Tým je umožnená rýchla výmena čelustí.

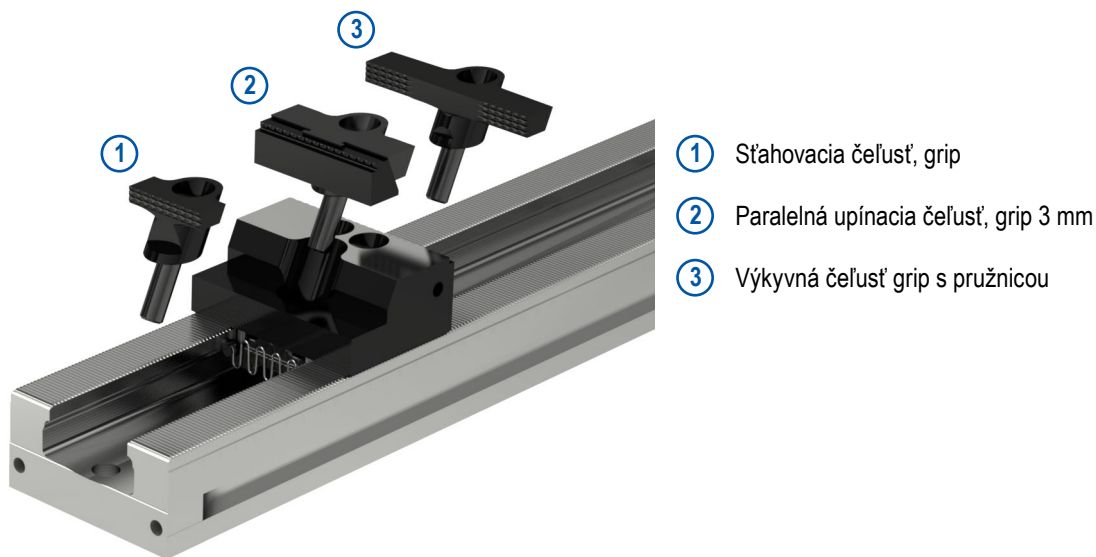

Spojenie upínacích líšt

Pomocou spojovacieho kusu je možné navzájom spájať dve alebo niekoľko upínacích líšt Verso, popr. ich aj predlžovať.

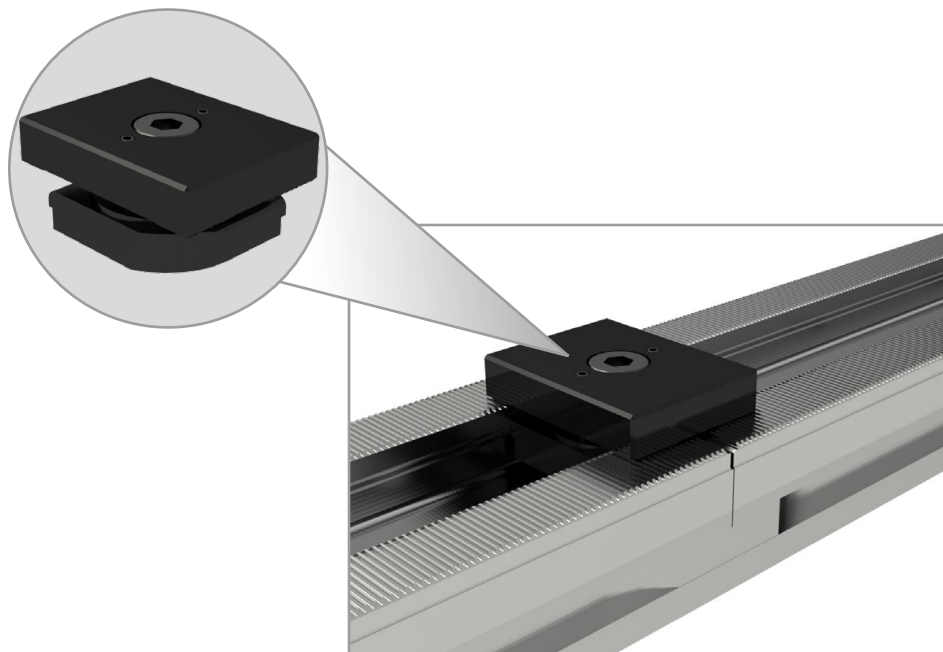

PolyClamp – Verso

- ▲ možnosť použitia pre jednoduché a viacnásobné zveráky
- ▲ viacnásobné upínanie pomocou klinových upínacích čelustí
- ▲ obrobky je možné upínať na 3 osových, 4 osových i 5 osových strojoch
- ▲ upínanie na MNG alebo PNG je možné

Rozsah dodávky:

Základné teleso bez čelustí

Verso

MMG

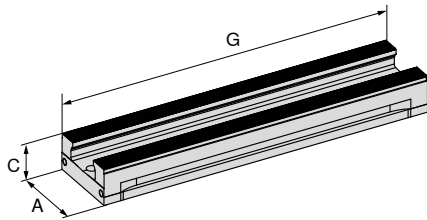

NEW

80 914 ...

EUR
Y4

A	C	G	MXC	WT	
mm	mm	mm	kN	kg	
90	45	260	0 - 50	5,0	804,00 09000
90	45	400	0 - 50	7,7	1.060,00 09100
90	45	500	0 - 50	9,6	1.280,00 09200
90	45	600	0 - 50	11,5	1.540,00 09300
90	45	650	0 - 50	12,5	1.640,00 09400

Tabuľka montážnych rozmerov Verso

Upínacia lišta

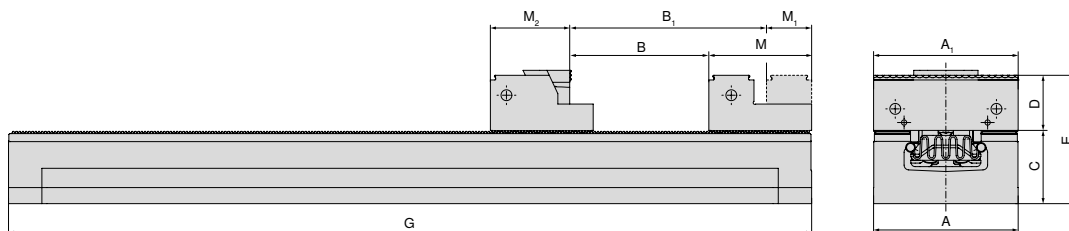

A	A ₁	B	B ₁	C	D	E	G	M	M ₁	M ₂
mm	mm	mm	mm	mm	mm	mm	mm	mm	mm	mm
90	40 / 65 / 90	145	181	45	35	80	260	64	28	53,5
90	40 / 65 / 90	285	321	45	35	80	400	64	28	53,5
90	40 / 65 / 90	385	421	45	35	80	500	64	28	53,5
90	40 / 65 / 90	485	521	45	35	80	600	64	28	53,5
90	40 / 65 / 90	535	571	45	35	80	650	64	28	53,5



Pri používaní výkyvnej čeluste grip 90 mm a paralelných upínacích čelustí sa líšia rozmery B, B₁ a M₂.

Prehľad zverákov

Rozmery spodnej strany	115	Prehľad upínacích rozsahov	116
Systémové príslušenstvo	117–124	Obecné príslušenstvo	164–183

Rozmery spodnej strany zveráka Verso

Šírka základného telesa 90 mm,
dĺžka 260 mm

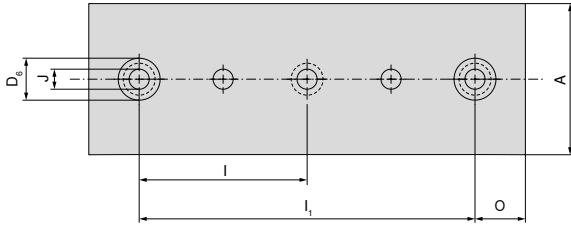

A	D ₆ H7	I _{±0,015}	I _{1±0,015}	J _{F7}	O _{±0,015}
mm	mm	mm	mm	mm	mm
90	25	100	200	12	30

Šírka základného telesa 90 mm,
dĺžka 600 mm

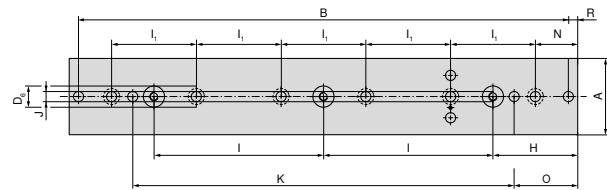

A	B	D ₆ H7	H _{±0,015}	I _{±0,015}	I _{1±0,015}	J _{F7}	K _{±0,015}	N	O _{±0,015}	R
mm	mm	mm	mm	mm	mm	mm	mm	mm	mm	mm
90	578	25	100	200	100	12	450	50	75	11

Šírka základného telesa 90 mm,
dĺžka 400 mm

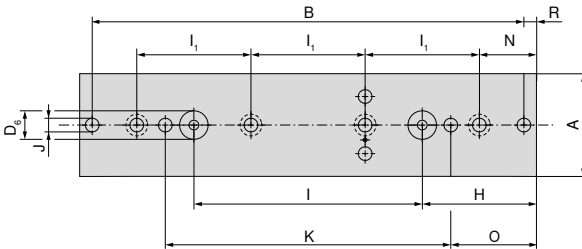

A	B	D ₆ H7	H _{±0,015}	I _{±0,015}	I _{1±0,015}	J _{F7}	K _{±0,015}	N	O _{±0,015}	R
mm	mm	mm	mm	mm	mm	mm	mm	mm	mm	mm
90	378	25	100	200	100	12	250	50	75	11

Šírka základného telesa 90 mm,
dĺžka 650 mm

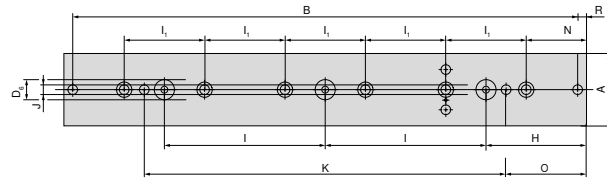

A	B	D ₆ H7	H _{±0,015}	I _{±0,015}	I _{1±0,015}	J _{F7}	K _{±0,015}	N	O _{±0,015}	R
mm	mm	mm	mm	mm	mm	mm	mm	mm	mm	mm
90	628	25	125	200	100	12	450	75	100	11

Šírka základného telesa 90 mm,
dĺžka 500 mm

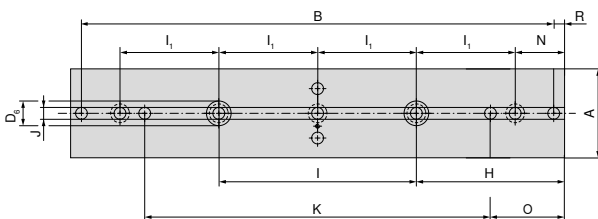

A	B	D ₆ H7	H _{±0,015}	I _{±0,015}	I _{1±0,015}	J _{F7}	K _{±0,015}	N	O _{±0,015}	R
mm	mm	mm	mm	mm	mm	mm	mm	mm	mm	mm
90	478	25	150	200	100	12	350	50	75	11

Prehľad upínacích rozsahov zveráka Verso

Rozsah upínania ukazuje max. veľkosť obrobku v závislosti od počtu upínacích miest v rámci jednotlivých dĺžok upínacej lišty.

Prestaviteľné čeluste so sťahovacou čelustou grip 40 mm

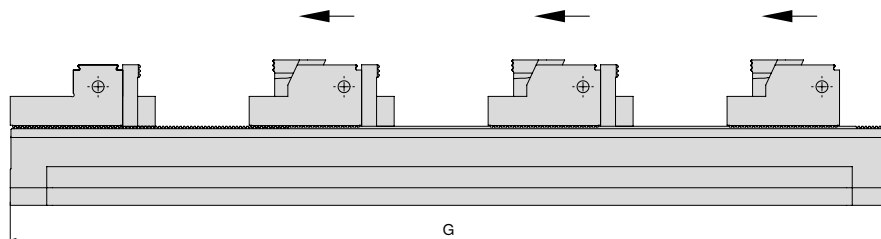

G mm	Počet obrobkov							Artikel č. Zveráky
	1	2	3	4	5	6	7	
260	134	36	–	–	–	–	–	80 914 09000
400	274	106	50	22	–	–	–	80 914 09100
500	374	156	82	45	24	–	–	80 914 09200
600	474	206	116	72	44	26	–	80 914 09300
650	524	230	135	84	54	34	20	80 914 09400

Prestaviteľné čeluste s paralelnými upínacími čelustami

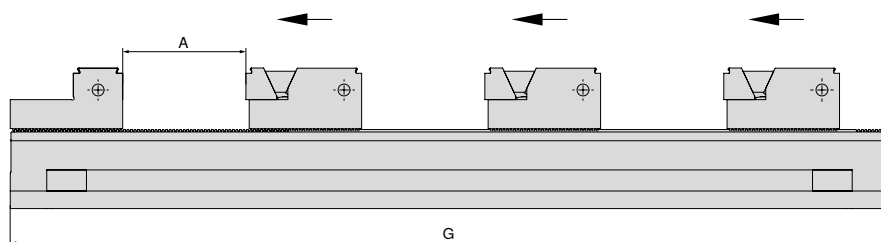

G mm	Počet obrobkov									Artikel č. Zveráky
	1 A	2 A	3 A	4 A	5 A	6 A	7 A	8 A	9 A	
260	175	59	–	–	–	–	–	–	–	80 914 09000
400	315	129	67	27	10	–	–	–	–	80 914 09100
500	415	179	100	61	30	15	–	–	–	80 914 09200
600	515	229	133	86	57	32	19	10	–	80 914 09300
650	565	254	150	98	67	46	26	16	8	80 914 09400

S klinovými upínacími čelustami

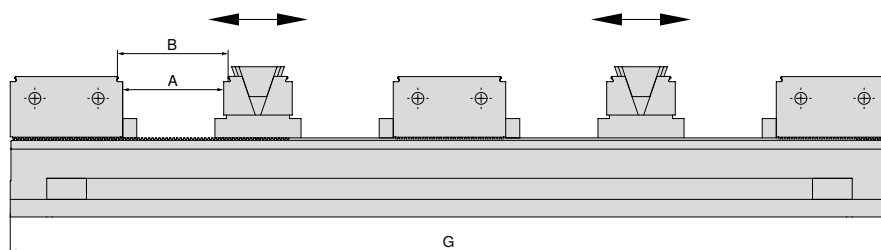

G mm	Počet obrobkov								Artikel č. Zveráky
	2		4		6		8		
	A	B	A	B	A	B	A	B	
260	45	50	–	–	–	–	–	–	80 914 09000
400	115	120	31	36	–	–	–	–	80 914 09100
500	165	170	56	61	19	24	–	–	80 914 09200
600	215	220	81	86	36	41	14	19	80 914 09300
650	240	245	93	98	44	49	20	25	80 914 09400

Prehľad systémových čelustí

Dorazová čelusť, pevná, grip 2,9 mm

▲ cena za kus

pre šírku zveráka	A	A ₁	D	D ₁	D ₂	E	M	M ₁	M ₂	EUR	Y4	NCG	H5G / -S / -Z	X5G-Z / -S	ESG 4	ESG 5	HDG 2	ZSG 4	ZSG mini	DSG 4	Verso	HSG		
90	90		32	34,9			64			342,00	NEW												●	

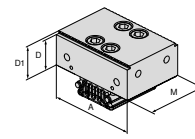

Otočná čelusť, pevná, hladká

▲ cena za kus

pre šírku zveráka	A	A ₁	D	D ₁	D ₂	E	M	M ₁	M ₂	EUR	Y4	NCG	H5G / -S / -Z	X5G-Z / -S	ESG 4	ESG 5	HDG 2	ZSG 4	ZSG mini	DSG 4	Verso	HSG		
90	90		34,9	17			64	35,9	28,1	364,00	NEW												●	

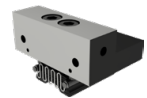
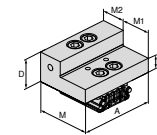

Dorazová čelusť, pevná, grip 2,9 mm

▲ cena za kus

pre šírku zveráka	A	A ₁	D	D ₁	D ₂	E	M	M ₁	M ₂	EUR	Y4	NCG	H5G / -S / -Z	X5G-Z / -S	ESG 4	ESG 5	HDG 2	ZSG 4	ZSG mini	DSG 4	Verso	HSG		
90	65		34,9	32	17		64	28,1	35,9	352,00	NEW												●	
90	65	40	34,9	32	17		64	28,1	35,9	340,00	NEW													●
90	90		34,9	32	17		64	28,1	35,9	364,00	NEW													●

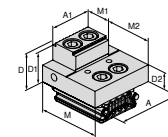

Otočná-nastavovacia čelusť profilovaná, grip 2,9 mm

▲ cena za kus

pre šírku zveráka	A	A ₁	D	D ₁	D ₂	E	M	M ₁	M ₂	EUR	Y4	NCG	H5G / -S / -Z	X5G-Z / -S	ESG 4	ESG 5	HDG 2	ZSG 4	ZSG mini	DSG 4	Verso	HSG		
90	65		34,9	32	17		64	42	22	352,00	NEW												●	
90	65	40	34,9	32	17		64	42	22	340,00	NEW													●
90	90		34,9	32	17		64	42	22	364,00	NEW													●

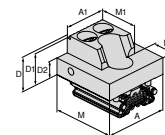

Otočná prestaviteľná čelusť, hladká

▲ cena za kus

pre šírku zveráka	A	A ₁	D	D ₁	D ₂	E	M	M ₁	M ₂	EUR	Y4	NCG	H5G / -S / -Z	X5G-Z / -S	ESG 4	ESG 5	HDG 2	ZSG 4	ZSG mini	DSG 4	Verso	HSG		
90	90		34,9	17			64	42	22	364,00	NEW												●	

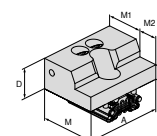

Prehľad systémových čelustí

Otočná prestavitelná čelusť, vysoká

▲ cena za kus

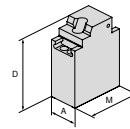

pre šírku zveráka	A	A ₁	D	D ₁	D ₂	E	M	M ₁	M ₂
90	65		165				124		

EUR 1.220,00

NEW

Y4

NCG	H5G / -S / -Z	X5G-Z / -S	ESG 4	ESG 5	HDG 2	ZSG 4	ZSG mini	DSG 4	Verso	HSG
									●	

80 914 31700

Prizmatická čelusť, hladká, grip 2,9 mm

▲ cena za kus

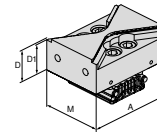

pre šírku zveráka	A	A ₁	D	D ₁	D ₂	E	M	M ₁	M ₂
90	90		34,9	32			64		

EUR 364,00

NEW

Y4

NCG	H5G / -S / -Z	X5G-Z / -S	ESG 4	ESG 5	HDG 2	ZSG 4	ZSG mini	DSG 4	Verso	HSG
									●	

80 914 31900

Klinová upínacia čelusť

▲ cena za kus

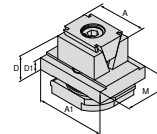

pre šírku zveráka	A	A ₁	D	D ₁	D ₂	E	M	M ₁	M ₂
90	40	65	35	11			49		
90	40	65	39	11			49		

EUR 347,00
236,00

NEW

Y4

NCG	H5G / -S / -Z	X5G-Z / -S	ESG 4	ESG 5	HDG 2	ZSG 4	ZSG mini	DSG 4	Verso	HSG
									●	
									●	

80 914 32100
80 914 32400

Klinové upínacie čeluste, grip

▲ cena za kus

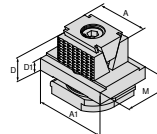

pre šírku zveráka	A	A ₁	D	D ₁	D ₂	E	M	M ₁	M ₂
90	40	65	35	11			49		
90	40	65	39	11			49		

EUR 371,00
236,00

NEW

Y4

NCG	H5G / -S / -Z	X5G-Z / -S	ESG 4	ESG 5	HDG 2	ZSG 4	ZSG mini	DSG 4	Verso	HSG
									●	
									●	

80 914 32200
80 914 32500

Klinové upínacie čeluste, grip 3 mm

▲ cena za kus

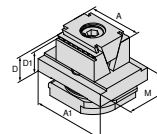

pre šírku zveráka	A	A ₁	D	D ₁	D ₂	E	M	M ₁	M ₂
90	40	65	35	32			49		

EUR 371,00

NEW

Y4

NCG	H5G / -S / -Z	X5G-Z / -S	ESG 4	ESG 5	HDG 2	ZSG 4	ZSG mini	DSG 4	Verso	HSG
									●	

80 914 32300

Prehľad systémových čelustí

Čeľusť, grip

▲ cena za kus

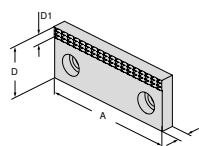

pre šírku zveráka	A	A ₁	D	D ₁	D ₂	E	M	M ₁	M ₂	EUR	NEW	Y4	NCG	H5G / -S / -Z	X5G-Z / -S	ESG 4	ESG 5	HDG 2	ZSG 4	ZSG mini	DSG 4	Verso	HSG	
65	65		35	7			10			41,00		80 889 656												
65	40		35	7			10			36,80		80 889 406												●
90	90		35	7			10			46,50		80 889 906												●

Mäkká čeľusť

▲ materiál: 16MnCr5

▲ cena za kus

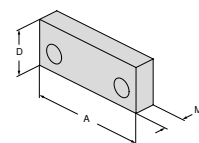

pre šírku zveráka	A	A ₁	D	D ₁	D ₂	E	M	M ₁	M ₂	EUR	NEW	Y4	NCG	H5G / -S / -Z	X5G-Z / -S	ESG 4	ESG 5	HDG 2	ZSG 4	ZSG mini	DSG 4	Verso	HSG	
65	65		35				16			41,00		80 889 657												●
65	40		35				16			37,80		80 889 407												●
90	90		35				16			49,70		80 889 907												●

Základná čeľusť

▲ cena za kus

▲ pre hliníkovú čeľusť artikel č. 80 914 34200

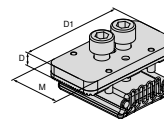

pre šírku zveráka	A	A ₁	D	D ₁	D ₂	E	M	M ₁	M ₂	EUR	NEW	Y4	NCG	H5G / -S / -Z	X5G-Z / -S	ESG 4	ESG 5	HDG 2	ZSG 4	ZSG mini	DSG 4	Verso	HSG	
90			9,1	80			40			212,00		80 914 34100												●

Mäkká hliníková čeľusť

▲ cena za kus

▲ pre základnú čeľusť artikel č. 80 914 34100

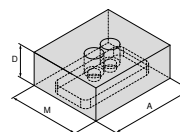

pre šírku zveráka	A	A ₁	D	D ₁	D ₂	E	M	M ₁	M ₂	EUR	NEW	Y4	NCG	H5G / -S / -Z	X5G-Z / -S	ESG 4	ESG 5	HDG 2	ZSG 4	ZSG mini	DSG 4	Verso	HSG	
90	90		34,9				75			81,00		80 914 34200												●

Sťahovacia čeľusť, grip

▲ cena za kus

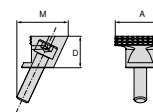

pre šírku zveráka	A	A ₁	D	D ₁	D ₂	E	M	M ₁	M ₂	EUR	NEW	Y4	NCG	H5G / -S / -Z	X5G-Z / -S	ESG 4	ESG 5	HDG 2	ZSG 4	ZSG mini	DSG 4	Verso	HSG	
90	40		25				41			105,00		80 914 32600												●

Prehľad systémových čelustí

Sťahovacia čelusť, grip – guľatá

▲ cena za kus

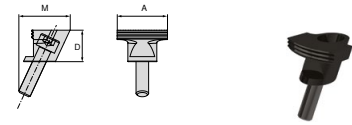

pre šírku zveráka	A	A ₁	D	D ₁	D ₂	E	M	M ₁	M ₂	EUR	Y4	NEW	NCG	H5G / -S / -Z	X5G-Z / -S	ESG 4	ESG 5	HDG 2	ZSG 4	ZSG mini	DSG 4	Verso	HSG			
90	40		25				41			118,00													●			
												80 914 32700														

Paralelná upínacia čelusť, grip – guľatá

▲ cena za kus

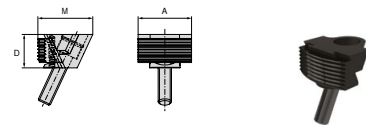

pre šírku zveráka	A	A ₁	D	D ₁	D ₂	E	M	M ₁	M ₂	EUR	Y4	NEW	NCG	H5G / -S / -Z	X5G-Z / -S	ESG 4	ESG 5	HDG 2	ZSG 4	ZSG mini	DSG 4	Verso	HSG		
90	40		25				41			219,00													●		
												80 914 32800													

Paralelná upínacia čelusť, grip 3 mm

▲ cena za kus

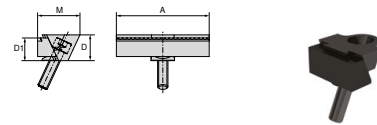

pre šírku zveráka	A	A ₁	D	D ₁	D ₂	E	M	M ₁	M ₂	EUR	Y4	NEW	NCG	H5G / -S / -Z	X5G-Z / -S	ESG 4	ESG 5	HDG 2	ZSG 4	ZSG mini	DSG 4	Verso	HSG			
90	40		25	22			41			175,00													●			
90	65		25	22			41			216,00													●			
90	90		25	22			41			259,00													●			
												80 914 32900														
												80 914 33000														
												80 914 33100														

Výkyvná čelusť, grip

▲ cena za kus

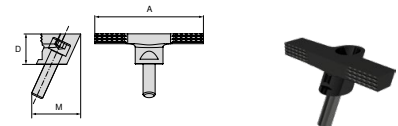

pre šírku zveráka	A	A ₁	D	D ₁	D ₂	E	M	M ₁	M ₂	EUR	Y4	NEW	NCG	H5G / -S / -Z	X5G-Z / -S	ESG 4	ESG 5	HDG 2	ZSG 4	ZSG mini	DSG 4	Verso	HSG		
90	90		25				41			182,00													●		
												80 914 33200													

Upínací klinok

▲ cena za kus

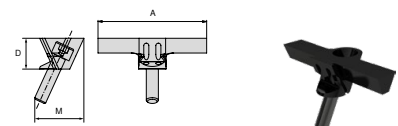

pre šírku zveráka	A	A ₁	D	D ₁	D ₂	E	M	M ₁	M ₂	EUR	Y4	NEW	NCG	H5G / -S / -Z	X5G-Z / -S	ESG 4	ESG 5	HDG 2	ZSG 4	ZSG mini	DSG 4	Verso	HSG		
90	90		25				41			200,00													●		
												80 914 33300													

Prehľad systémových čelustí

Paralelná upínacia čelusť, hladká

▲ cena za kus

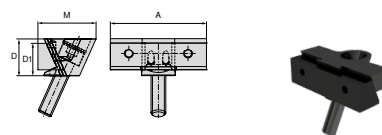

pre šírku zveráka	A	A ₁	D	D ₁	D ₂	E	M	M ₁	M ₂	EUR	Y4	NEW	NCG	H5G / -S / -Z	X5G-Z / -S	ESG 4	ESG 5	HDG 2	ZSG 4	ZSG mini	DSG 4	Verso	HSG	
90	40		25	22			41			167,00	80 914 33400													
90	65		25	22			41			271,00	80 914 33500													●
90	90		25	22			41			286,00	80 914 33600													●

Paralelná upínacia čelusť, grip

▲ cena za kus

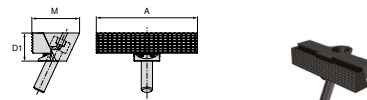

pre šírku zveráka	A	A ₁	D	D ₁	D ₂	E	M	M ₁	M ₂	EUR	Y4	NEW	NCG	H5G / -S / -Z	X5G-Z / -S	ESG 4	ESG 5	HDG 2	ZSG 4	ZSG mini	DSG 4	Verso	HSG	
90	90		25				42,5			259,00	80 914 33700													●

Upínacia čelusť, oceľ

▲ materiál: 16MnCr5

▲ cena za kus

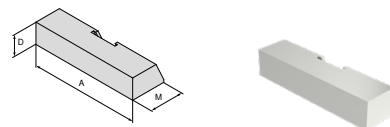

pre šírku zveráka	A	A ₁	D	D ₁	D ₂	E	M	M ₁	M ₂	EUR	Y4	NEW	NCG	H5G / -S / -Z	X5G-Z / -S	ESG 4	ESG 5	HDG 2	ZSG 4	ZSG mini	DSG 4	Verso	HSG	
90	90		18				30			83,20	80 914 33800													●

Upínacia čelusť, hliník

▲ cena za kus

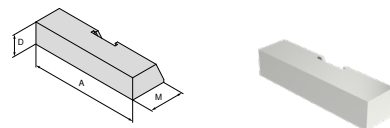

pre šírku zveráka	A	A ₁	D	D ₁	D ₂	E	M	M ₁	M ₂	EUR	Y4	NEW	NCG	H5G / -S / -Z	X5G-Z / -S	ESG 4	ESG 5	HDG 2	ZSG 4	ZSG mini	DSG 4	Verso	HSG	
90	90		18				30			83,20	80 914 33900													●

Adaptérová doska, pevná

▲ pre upínanie 6násobných otočných čelustí

▲ cena za kus

▲ vr. krycích skrutiek

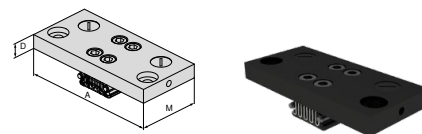

pre šírku zveráka	A	A ₁	D	D ₁	D ₂	E	M	M ₁	M ₂	EUR	Y4	NEW	NCG	H5G / -S / -Z	X5G-Z / -S	ESG 4	ESG 5	HDG 2	ZSG 4	ZSG mini	DSG 4	Verso	HSG	
90	160		17				74			453,00	80 914 34000													●

Prehľad systémových čelustí

6násobná otočná čelusť

- ▲ 1 = hladká, s povlakom WC
- ▲ 2 = grip so stupňom 3 mm
- ▲ 3 = grip so stupňom 8 mm
- ▲ 4 = grip so stupňom 18 mm
- ▲ 5 = guľatý grip so stupňom 8 mm
- ▲ 6 = guľatý grip
- ▲ $M_{max} = 60 \text{ Nm}$
- ▲ vr. upínacej skrutky
- ▲ cena za kus

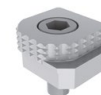
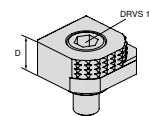

pre šírku zveráka	A	A ₁	D	D ₁	D ₂	E	M	M ₁	M ₂	EUR	Y4	NCG	H5G / -S / -Z	X5G-Z / -S	ESG 4	ESG 5	HDG 2	ZSG 4	ZSG mini	DSG 4	Verso	HSG
			18							80,60	80 892 246	●	●	●	●			●		●	●	

6násobná otočná čelusť, karbid grip

- ▲ 1 = hladká
- ▲ 2 = karbidový grip
- ▲ 3 = karbidový grip so stupňom 3 mm
- ▲ 4 = karbidový grip so stupňom 8 mm
- ▲ 5 = karbidový guľatý grip so stupňom 8 mm
- ▲ 6 = karbidový guľatý grip
- ▲ vr. upínacej skrutky
- ▲ cena za kus

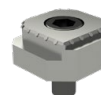
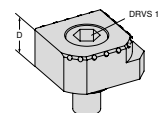

pre šírku zveráka	A	A ₁	D	D ₁	D ₂	E	M	M ₁	M ₂	EUR	Y4	NCG	H5G / -S / -Z	X5G-Z / -S	ESG 4	ESG 5	HDG 2	ZSG 4	ZSG mini	DSG 4	Verso	HSG
			18							117,00	80 890 35300	●	●	●	●			●		●	●	

Prehľad podložiek pod obrobok

Podložka pod obrobok na nasrútkovanie na pevnú čeľusť

▲ cena za 2 kusy

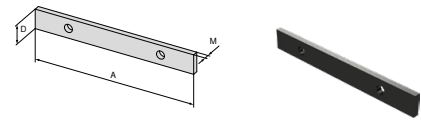

pre šírku zveráka	A	A ₁	D	D ₁	D ₂	E	M	M ₁	M ₂
90	90		11				3		

EUR 52,90

NEW

Y4

NCG	H5G / -S / -Z	X5G-Z / -S	ESG 4	ESG 5	HDG 2	ZSG 4	ZSG mini	DSG 4	Verso	HSG
									●	

80 914 73100

Podložka pod obrobok, odsadená

▲ cena za 2 kusy

▲ šírka 40 mm

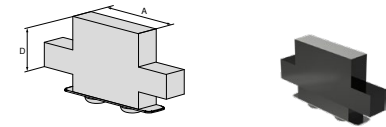

pre šírku zveráka	A	A ₁	D	D ₁	D ₂	E	M	M ₁	M ₂
90	40		30						
90	40		25						

EUR 87,40
87,40

NEW

Y4

NCG	H5G / -S / -Z	X5G-Z / -S	ESG 4	ESG 5	HDG 2	ZSG 4	ZSG mini	DSG 4	Verso	HSG
									●	
									●	

80 914 70200
80 914 70100

Podložka pod obrobok, odsadená

▲ cena za 2 kusy

▲ šírka 65 mm

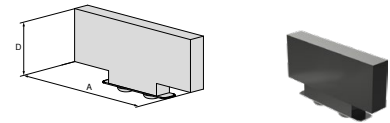

pre šírku zveráka	A	A ₁	D	D ₁	D ₂	E	M	M ₁	M ₂
90	65		11						
90	65		17						
90	65		25						
90	65		30						

EUR 87,40
87,40
87,40
87,40

NEW

Y4

NCG	H5G / -S / -Z	X5G-Z / -S	ESG 4	ESG 5	HDG 2	ZSG 4	ZSG mini	DSG 4	Verso	HSG
									●	
									●	
									●	
									●	

80 914 71100
80 914 71200
80 914 71300
80 914 71400

Podložka pod obrobok, odsadená

▲ cena za 2 kusy

▲ šírka 90 mm

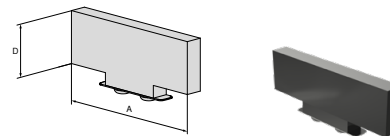

pre šírku zveráka	A	A ₁	D	D ₁	D ₂	E	M	M ₁	M ₂
90	90		11						
90	90		17						
90	90		25						
90	90		30						

EUR 87,40
87,40
87,40
87,40

NEW

Y4

NCG	H5G / -S / -Z	X5G-Z / -S	ESG 4	ESG 5	HDG 2	ZSG 4	ZSG mini	DSG 4	Verso	HSG
									●	
									●	
									●	
									●	

80 914 72100
80 914 72200
80 914 72300
80 914 72400

Prehľad systémového príslušenstva

Nastaviteľná podpera

- ▲ na tlmenie vibrácií
- ▲ výškovo nastaviteľná 16 – 17 mm

Verso

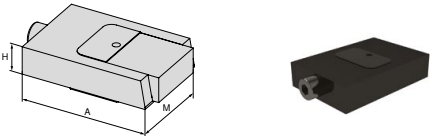

NEW

H mm	A mm	M mm	80 914 ...
16	72	50	EUR Y4 243,00 50100

Súprava upínacích skrutiek k T-drážke pre MNG

- Rozsah dodávky:**
upínacia skrutka a kameň do T drážky

Verso



NEW

Pre šírku drážky mm	G	80 914 ...
20	M12	EUR Y4 42,20 50500
22	M12	EUR Y4 49,70 50600
24	M12	EUR Y4 60,50 50700

Podpera

- ▲ na tlmenie vibrácií
- ▲ pre artikel č. 80 914 50100

Verso

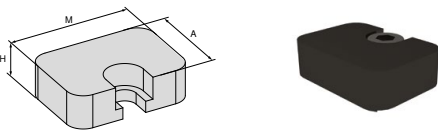

NEW

H mm	A mm	M mm	80 914 ...
8	20	28	EUR Y4 62,70 50200
13	20	28	EUR Y4 62,70 50300

Vyrovnávací čap

Verso



NEW

D ₁ mm	D ₂ mm	80 914 ...
12	14	EUR Y4 107,00 81400
12	16	EUR Y4 107,00 81600
12	18	EUR Y4 107,00 81800

Spojovací kus

- ▲ pre spojenie 2 základných telies

Verso

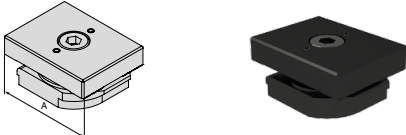

NEW

A mm	80 914 ...
90	EUR Y4 183,00 50400

Plechový kryt

Verso

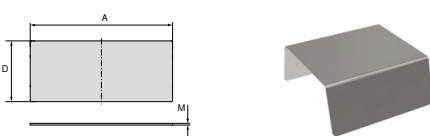

NEW

A mm	D mm	M mm	80 914 ...
50	84	0,5	EUR Y4 15,80 51000
50	86	0,5	EUR Y4 6,80 50800
200	86	0,5	EUR Y4 10,10 50900



Dlho očakávané riešenie – teraz i pre rotačné obrobky

Obrábanie guľatých obrobkov sa momentálne stalo bežnou záležitosťou. V podobe stacionárneho trojčelustového skľučovadla SBF 3 teraz máme vo svojom portfóliu nové riešenie - plno kompatibilné s vlastnými upínacími systémami s nulovým bodom MNG a PNG pre rýchlu a nekomplikovanú manipuláciu.

Výhody pre Vás:

- ▲ vhodné pre 3 a 5osové obrábanie rotačných obrobkov
- ▲ kompatibilné s upínacími systémami s nulovým bodom PNG a MNG
- ▲ systém rýchlej výmeny čelustí s odistovaním jednotlivých čelustí
- ▲ vreteno s ovládaním cez šesťhran



SBF 3 Ø 200 mm



SBF 3 Ø 315 mm

Technické informácie – rez

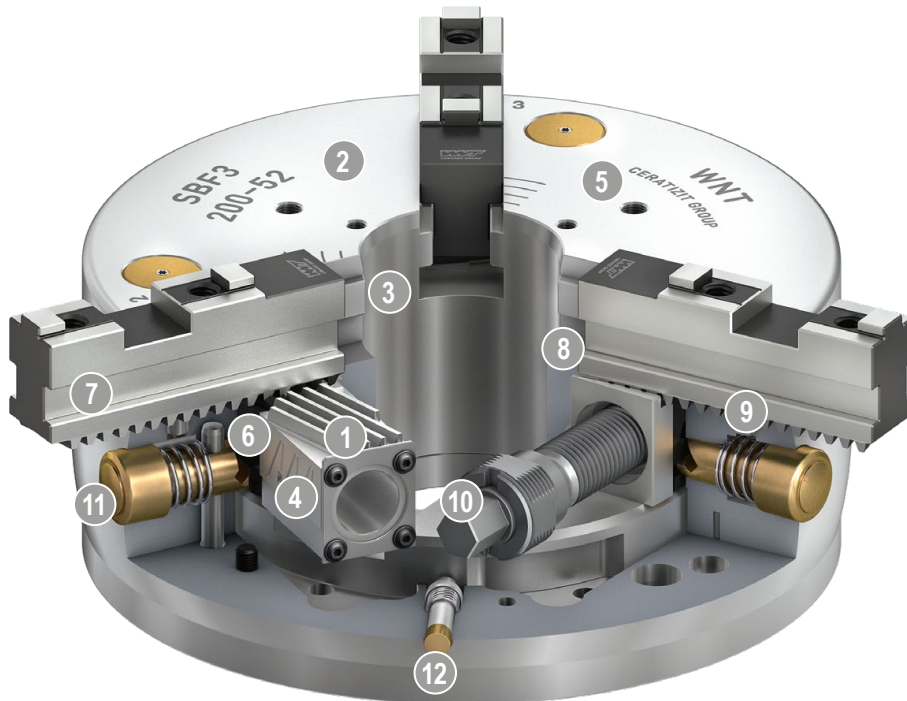

- | | |
|--|---|
| <p>1 Pohon klinovej tyče
umožňuje dosiahnutie excelentných výsledkov obrábania</p> | <p>7 Základné čeluste so šikmým ozubením (SFG)</p> |
| <p>2 Kalené a extrémne tuhé základné teleso
teda dlhšia životnosť a maximálna precíznosť –
i v prípade maximálnej upínacej sily</p> | <p>8 Blokovací mechanizmus
garantuje bezpečné vzájomné zapadanie ozubenia
základnej čelusti a ozubenia klinovej tyče</p> |
| <p>3 Veľká priechodná diera
pre obrábanie všetkých bežných priemerov tyčového
materiálu (na želanie: zväčšenie priechodnej diery)</p> | <p>9 Aretačný kolík
pre predbežné polohovanie základnej čeluste</p> |
| <p>4 Optimalizovaný systém mazania
pre dosiahnutie vysokej účinnosti</p> | <p>10 Ovládanie cez šesťhran
teda jednoduchšia manipulácia</p> |
| <p>5 Upínací závit
pre dorazy obrabkov, popr. hviezdicové dorazy</p> | <p>11 Tlačidlo pre výmenu čelusti
pre minimalizáciu prípravných časov</p> |
| <p>6 Systém rýchlej výmeny čelustí
s odistovaním jednotlivých čelustí a teda
i minimálnymi časmi pre nové nastavenie</p> | <p>12 Indikačný kolík
pre vizuálnu kontrolu zdvihu ručného skľučovadla</p> |

Trojčelustové skľučovadlo SBF 3 (Ø 200 mm) s konzolou

- ▲ vhodný pre 3osové i 5osové obrábanie guľatých obrobkov
- ▲ kompatibilný s upínacími systémami s nulovým bodom PNG a MNG (upínacie čapy pre upínací systém s nulovým bodom sa musí objednať samostatne)
- ▲ systém rýchlej výmeny čelustí s odistovaním jednotlivých čelustí
- ▲ vreteno s ovládaním cez šesťhran

Rozsah dodávky:

Trojčelustové skľučovadlo SBF 3 (Ø 200 mm) vr. konzoly (kompatibilné s PNG a MNG)

1 súprava základných čelustí GBA

1 súprava stupňovitých čelustí SB-H

6 upínacích skrutiek a upínací kľúč

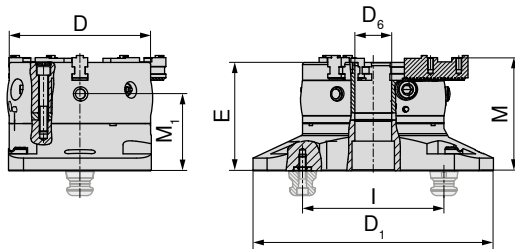

80 913 ...

EUR
Y4

3.964,00 20000

D	D ₁	D ₆	E	I	M	M ₁	MXC	TQX	DRVS	Zdvih / čelusť	Rázvor zubov	WT
mm	mm	mm	mm	mm	mm	mm	kN	Nm	mm	mm	mm	kg
200	340	52	153,3	200	160,1	108,8	100	120	12	7	4,8	49,5

Trojčelustové skľučovadlo SBF 3 (Ø 315 mm) s konzolou

- ▲ vhodný pre 3osové i 5osové obrábanie guľatých obrobkov
- ▲ kompatibilný s upínacími systémami s nulovým bodom PNG a MNG (upínacie čapy pre upínací systém s nulovým bodom sa musí objednať samostatne)
- ▲ systém rýchlej výmeny čelustí s odistovaním jednotlivých čelustí
- ▲ vreteno s ovládaním cez šesťhran

Rozsah dodávky:

Trojčelustové skľučovadlo SBF 3 (Ø 315 mm) vr. konzoly (kompatibilné s PNG a MNG)

1 súprava základných čelustí GBA

1 súprava stupňovitých čelustí SB-H

6 upínacích skrutiek a upínací kľúč

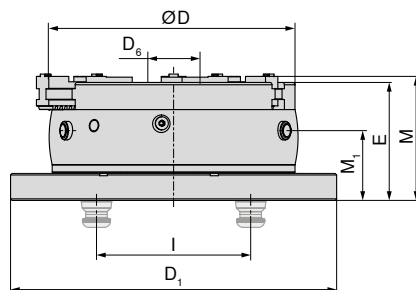

80 913 ...

EUR
Y4

6.537,00 31500

D	D ₁	D ₆	E	I	M	M ₁	MXC	TQX	DRVS	Zdvih / čelusť	Rázvor zubov	WT
mm	mm	mm	mm	mm	mm	mm	kN	Nm	mm	mm	mm	kg
315	423	92	153	200	160,86	90,5	180	220	16	9,9	7	95



Skľučovadlo je dimenzované výlučne pre stacionárne použitie – nepoužívajte ho ako rotačné skľučovadlo!

Prehľad systémových čelustí

Základné čeluste (GBA) – súprava

- ▲ základné čeluste so šikmým ozubením
- ▲ cena za súpravu à 3 ks

Rozsah dodávky:

3 základné čeluste so šikmým ozubením
vrátane skrutiek s valcovou hlavou

SBF
3

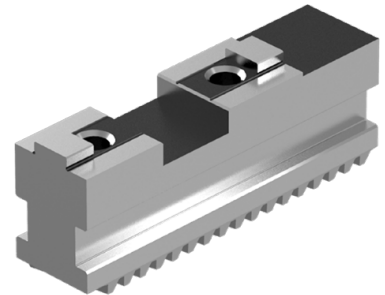
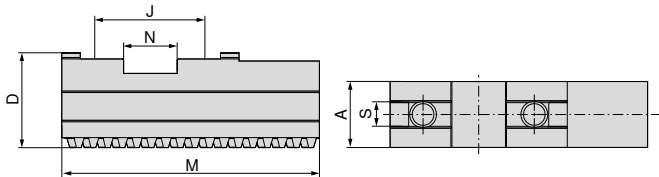

Pre	A	D	J	M	N	S	G	WT
	mm	mm	mm	mm	mm	mm		kg
SBF-3.200	22	32	40	90	20	10	M8x1	1,2
SBF-3.315	32	43	54	125	26	12	M12x1,5	3,1

80 913 ...

EUR
Y4
242,00 50300
400,00 60300

Mäkké výmenné čeluste (AB-W) – súprava

- ▲ cena za súpravu à 3 ks
- ▲ materiál: 16MnCr5

Rozsah dodávky:

3 mäkké výmenné čeluste

SBF
3

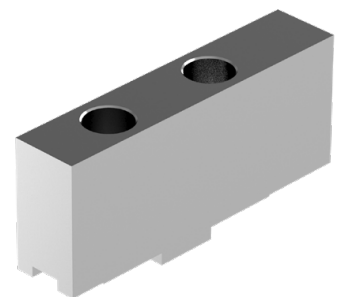
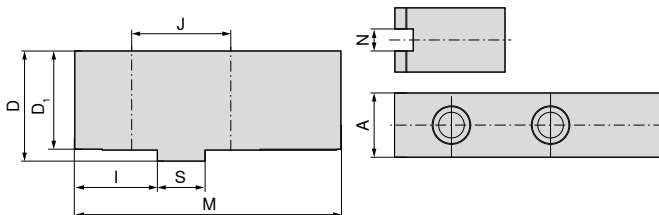

Pre	A	D	D ₁	I	J	M	N	S	Otvor pre	WT
	mm	mm	mm	mm	mm	mm	mm	mm		kg
SBF-3.200	22	47	43	35	40	105	10	20	M8	2,0
SBF-3.315	35	60	54	45	54	145	12	26	M12	5,6

80 913 ...

EUR
Y4
47,30 50400
98,20 60400

Prehľad systémových čelustí

Tvrdé stupňovité výmenné čeluste (AB-H) – súprava

▲ cena za súpravu à 3 ks

Rozsah dodávky:

3 tvrdé stupňovité výmenné čeluste

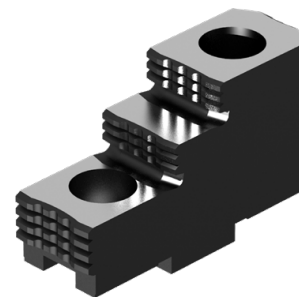
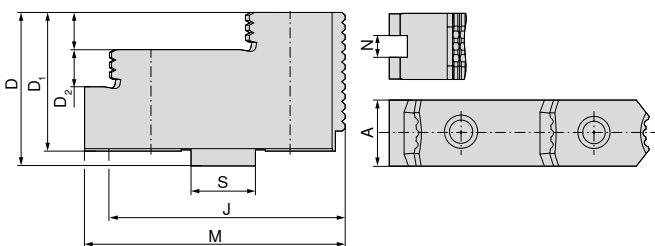
SBF
3

80 913 ...

EUR
Y4

Pre	A mm	D mm	D ₁ mm	D ₂ mm	J mm	M mm	N mm	S mm	Otvor pre	WT kg
SBF-3.200	22	42	38	10	40	71,7	10	20	M8	2,4
SBF-3.315	36	62	56	15	54	105	12	26	M12	3,3

207,00 50200
303,00 60200

Rozmerová tabuľka – Tvrdé stupňovité výmenné čeluste (AB-H)

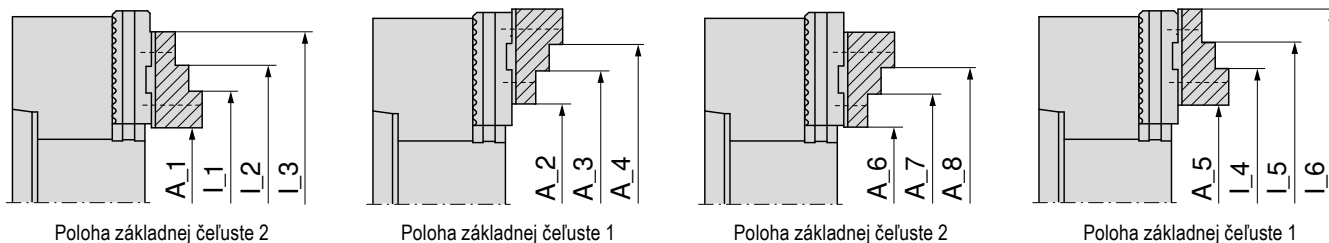

Trojčelustové skľučovadlo	Systémová čelusť	Vonkajšie upnutie							
		A_1	A_2	A_3	A_4	A_5	A_6	A_7	A_8
SBF-3.200	80 913 50200 SBF-3.AB-H.200.71.7.22.10	7-76	57-125	108-177	135-204	55-125	14-77	66-129	93-156
SBF-3.315	80 913 60200 SBF-3.AB-H.315.105.36.15	14-125	93-224	202-333	-	87-219	44-130	153-239	-

Trojčelustové skľučovadlo	Systémová čelusť	Vnútorne upnutie					
		I_1	I_2	I_3	I_4	I_5	I_6
SBF-3.200	80 913 50200 SBF-3.AB-H.200.71.7.22.10	72-141	99-168	151-220	120-189	147-216	199-268
SBF-3.315	80 913 60200 SBF-3.AB-H.315.105.36.15	93-204	202-313	-	167-298	276-407	-

Prehľad systémových čelustí

Tvrdé stupňovité blokové čeluste (SB-H) – súprava

▲ stupňovité blokové čeluste so šikmým ozubením

▲ cena za súpravu à 3 ks

Rozsah dodávky:

3 tvrdé stupňovité blokové čeluste

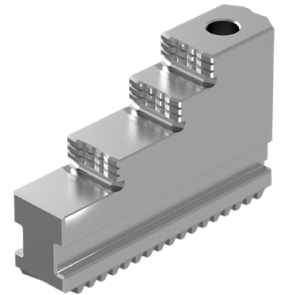
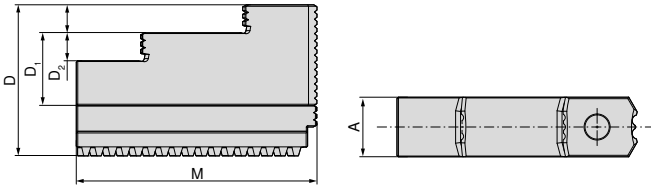
SBF
3

Pre	A	D	D ₁	D ₂	M	WT
	mm	mm	mm	mm	mm	kg
SBF-3.200	22	60	35	10	94	1,9
SBF-3.315	32	81	46	15	129	5,5

80 913 ...

EUR
Y4

420,00 50100

661,00 60100

Rozmerová tabuľka - Tvrdé stupňovité blokové čeluste (SB-H)

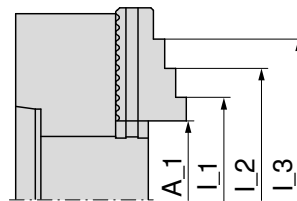
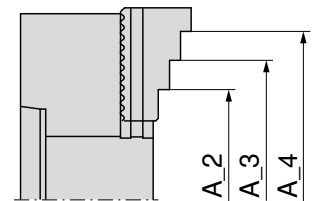
Tvrdé stupňovité blokové čeluste
ocel 16MnCr5, cementovaná, kalenáTvrdé stupňovité blokové čeluste
ocel 16MnCr5, cementovaná, kalená

Trojčelustové sklúčovadlo	Systémová čelusť	Vonkajšie upnutie				Vnútorne upnutie		
		A_1	A_2	A_3	A_4	I_1	I_2	I_3
SBF-3.200	80 913 50100 SBF-3.SB-H.200.94.22.10	6–74	59–128	111–180	138–207	70–138	97–165	149–217
SBF-3.315	80 913 60100 SBF-3.SB-H.315.129.32.15	12–124	89–210	189–420	–	91–203	199–311	–

Strojový ručný zverák

- ▲ skladný, univerzálny zverák s veľkým upínacím rozsahom
- ▲ čeľuste so stupňom a vodorovnou aj zvislou prizmou 120°
- ▲ obe strany možno opatriť dorazom pre materiál

HSG

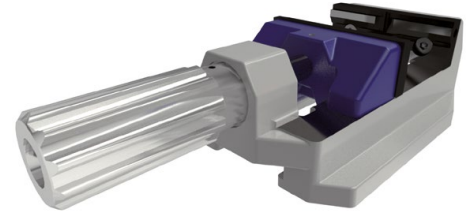
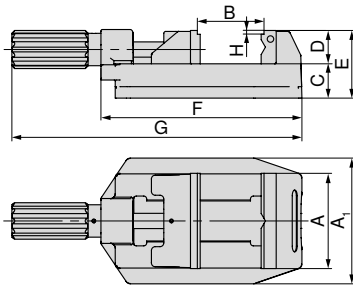

A	A ₁	B	C	D	E	F	G	H	WT
mm	mm	mm	mm	mm	mm	mm	mm	mm	kg
80	112	0 - 81	36	35	71	194	286,5	4	4,5
100	132	0 - 100	36	35	71	211	304,5	4	5,6
125	156	0 - 131	40	40	84	274	386	4	11,2

80 893 ...

EUR
Y4286,00 080
303,00 100
506,00 125

Strojový, ručný zverák s upínacou pákou

- ▲ bezpečné a rýchle upnutie obrobku pomocou upínacej páky
- ▲ skladný, univerzálny zverák s veľkým upínacím rozsahom
- ▲ čeľuste so stupňom a vodorovnou aj zvislou prizmou 120°
- ▲ obe strany možno opatriť dorazom pre materiál
- ▲ N = zdvih pri upínaní kľukou

HSG

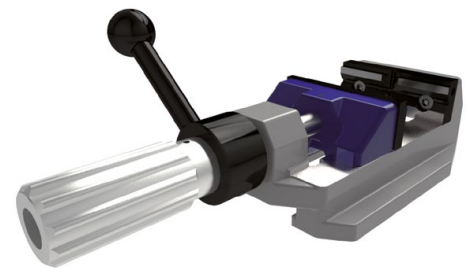
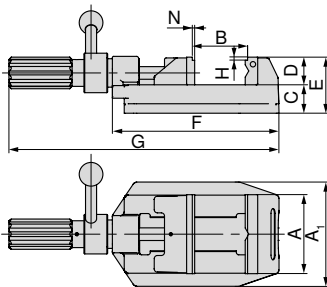

A	A ₁	B	C	D	E	F	G	H	N	WT
mm	mm	mm	mm	mm	mm	mm	mm	mm	mm	kg
100	132	0 - 100	36	35	71	211	342	4	1,5	6,1
125	156	0 - 133	44	40	84	274	405	4	1,5	11,7

80 893 ...

EUR
Y4491,00 101
702,00 126

Prehľad zverákov

Systémové príslušenstvo

132+133

Obecné príslušenstvo

164-183

Prehľad výmenných čeľustí

Stupňovitá čeľusť, hladká

▲ cena za kus

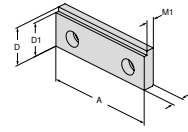

pre šírku zveráka	A	A ₁	D	D ₁	D ₂	E	M	M ₁	M ₂	EUR	Y4	NCG	H5G / -S / -Z	X5G-Z / -S	ESG 4	ESG 5	HDG 2	ZSG 4	ZSG mini	DSG 4	Verso	HSG		
80			35	31			10,2	7,2		49,00	80 893 082												●	
100			35	31			10,2	7,2		45,00	80 893 102													●
125			40	36			11,8	8,8		58,00	80 893 127													●

Stupňovitá čeľusť, 17 mm, hladká

▲ cena za kus

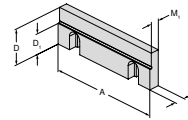

pre šírku zveráka	A	A ₁	D	D ₁	D ₂	E	M	M ₁	M ₂	EUR	Y4	NCG	H5G / -S / -Z	X5G-Z / -S	ESG 4	ESG 5	HDG 2	ZSG 4	ZSG mini	DSG 4	Verso	HSG		
125			40	23			11,5	9,5		123,00	80 892 244													●

Prizmatická čeľusť

▲ s vodorovnou a zvislou prizmou

▲ cena za kus

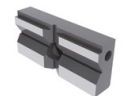
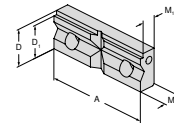

pre upínací priemer	A	A ₁	D	D ₁	D ₂	E	M	M ₁	M ₂	EUR	Y4	NCG	H5G / -S / -Z	X5G-Z / -S	ESG 4	ESG 5	HDG 2	ZSG 4	ZSG mini	DSG 4	Verso	HSG			
9 - 31	80		35	31			15,8	12,8		58,00	80 893 083													●	
9 - 31	100		35	31			15,8	12,8		74,00	80 893 103														●
11 - 41	125		40	36			17,8	14,8		129,00	80 893 128														●



→ Strana 164–173

Ďalší prehľad vhodných výmenných čeľustí.

Prehľad systémového príslušenstva

Doraz obrobku

- ▲ Upevňuje sa vždy na pevnú čelusť, vľavo, vpravo alebo na oboch stranách. K rýchlemu a bezpečnému dĺžkovému nastaveniu sa využíva zvieravá skrutka.

HSG



80 893 ...

EUR	265
Y4	
46,00	

Pre šírku
mm

80/100/125

Vodiace lišty

- ▲ zabráňuje úrazom
- ▲ zabráňuje strhávaniu, vyťahovaniu a otáčaniu

HSG

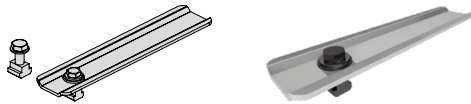

80 893 ...

EUR	260
Y4	
50,00	

Pre šírku
mm

80/100/125

Upínacia súprava

- ▲ Vďaka posuvným príložkám s excentricky výkyvným uložením je možné na stoloch stroja vytvárať ľubovoľné upínacie polohy s rôznym umiestnením T drážky. Ďalšia možnosť upnutia spočíva rovnako ako u vodiacej lišty 80 893 260 vo využití vnútornej drážky telesa zveráka.
- ▲ cena za súpravu

Rozsah dodávky:

2 polohovacie pätky vr. upínacieho príslušenstva.

HSG



80 893 ...

EUR	250
Y4	
132,00	

Pre šírku
mm

80/100/125

Pre šírku drážky
mm

12/14

Prehľad systémov s nulovým upínacím bodom MNG a PNG

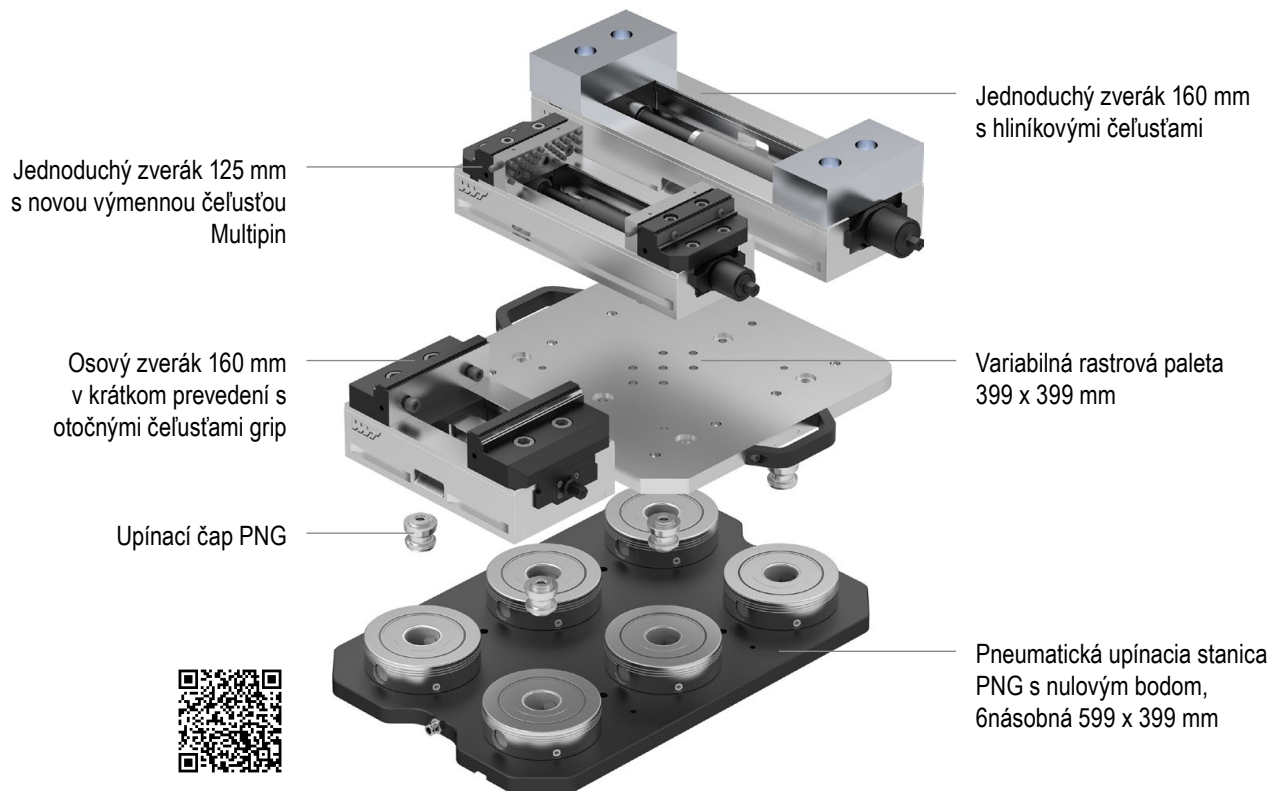

MNG – Kruhová základná doska

- ▲ MNG – Mechanický upínací systém s nulovým bodom
- ▲ kalená a brúsená
- ▲ presnosť opakovania $\leq 0,01$ mm
- ▲ vťahovacia sila 20 kN
- ▲ doťahovací moment 30 Nm

MNG

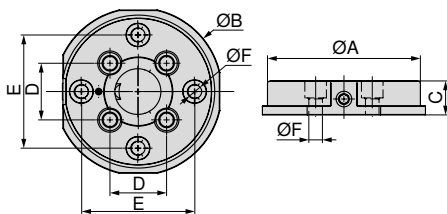

A	B	C _{+0,005}	D	E	F _{H7}	WT
mm	mm	mm	mm	mm	mm	kg
135	148	30	50	100	12	3,5

80 899 ...

EUR

Y4

571,00

125

Prehľad zverákov

Systémové príslušenstvo

144+145

Obecné príslušenstvo

164–183

MNG – Hranatá základná doska

- ▲ MNG – Mechanický upínací systém s nulovým bodom
- ▲ korozivzdorná a vákuovo kalená
- ▲ presnosť opakovania $\leq 0,01$ mm
- ▲ vŕťahovacia sila 20 kN u upínacieho čapu
- ▲ moment dotiahovania 30 Nm

MNG

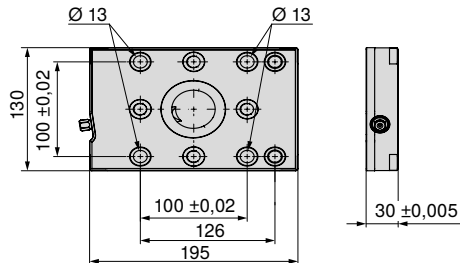

80 899 ...

EUR
Y4

702,00 65000

Veľkosť	WT
195x130 mm	5,2

MNG – Hranatá základná doska, 2násobná

- ▲ MNG – Mechanický upínací systém s nulovým bodom
- ▲ korozivzdorná a vákuovo kalená
- ▲ presnosť opakovania $\leq 0,01$ mm
- ▲ vŕťahovacia sila 20 kN u upínacieho čapu
- ▲ moment dotiahovania 30 Nm

MNG

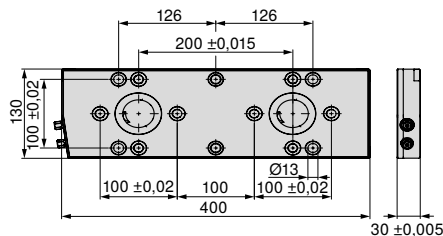

80 899 ...

EUR
Y4

1.650,00 65100

Veľkosť	WT
400x130 mm	11

Prehľad zverákov

Systémové príslušenstvo	144+145	Obecné príslušenstvo	164–183
Možnosti upínania pomocou systému MNG	146–148		

MNG – Hranatá základná doska, 3násobná

- ▲ MNG – Mechanický upínací systém s nulovým bodom
- ▲ korozivzdorná a vákuovo kalená
- ▲ presnosť opakovania $\leq 0,01$ mm
- ▲ vŕhovácia sila 20 kN u upínacieho čapu
- ▲ moment dotahovania 30 Nm

MNG

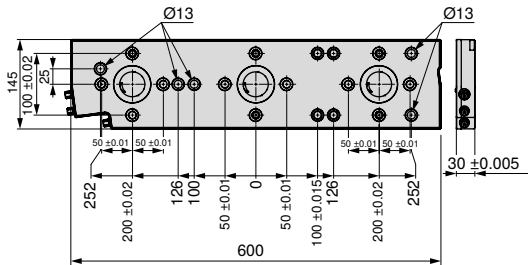

80 899 ...

EUR
Y4

2.340,00 65200

Veľkosť	WT
600x145 mm	18 kg

MNG – 3násobná základná doska 270 x 190 mm

- ▲ MNG – Mechanický upínací systém s nulovým bodom
- ▲ vŕhovácia sila 20 kN u upínacieho čapu
- ▲ 4 x upínacie otvory pre M12, pre vzdialenosť T-drážok 50 mm
- ▲ 8 x rastrový lícovaný otvor Ø12 F7/M12
- ▲ 4 x lícované otvory Ø18 H7 pre polohovanie
- ▲ moment dotahovania 30 Nm
- ▲ kalená a brúsená

MNG

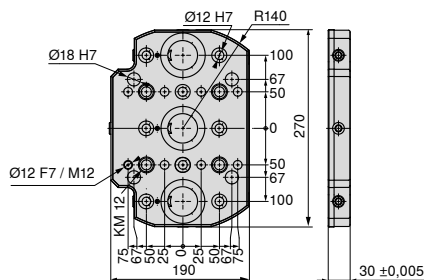

80 899 ...

EUR
Y4

2.110,00 230

Veľkosť	WT
270x190 mm	9 kg

Prehľad zverákov

Systémové príslušenstvo	144+145	Obecné príslušenstvo	164–183
Možnosti upínania pomocou systému MNG	146–148		

MNG – 4násobná základná doska, 330 x 400 mm

- ▲ MNG – Mechanický upínací systém s nulovým bodom
- ▲ nehrdzavejúca a kalená vo vákuu
- ▲ vŕhovácia sila 20 kN u upínacieho čapu
- ▲ 15 x montážne otvory pre M12, pre vzdialenosť T-drážok 50, 63, 100, 125 mm
- ▲ 13 x lícované diery Ø12 F7/M12
- ▲ 2 x lícované diery Ø18 G7 pre polohovanie
- ▲ 1 x lícované diery Ø12 F7 pre polohovanie

MNG

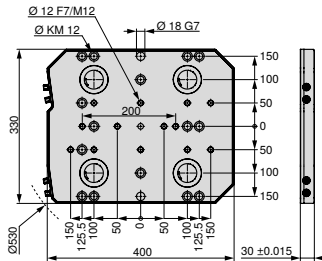

80 899 ...

EUR
Y43.290,00 63000¹⁾

Veľkosť	WT
330x400 mm	28

1) tovar nie je na sklade

MNG – 6násobná základná doska, 400 x 400 mm

- ▲ MNG – Mechanický upínací systém s nulovým bodom
- ▲ nehrdzavejúca a kalená vo vákuu
- ▲ vŕhovácia sila 20 kN u upínacieho čapu
- ▲ 14 x montážne otvory pre M16, pre vzdialenosť T-drážok 63, 80, 100, 125 mm
- ▲ 2 x montážne otvory pre M12
- ▲ 17 x lícované diery Ø12 F7/M12
- ▲ 2 x lícované diery Ø18 G7 pre polohovanie
- ▲ 1 x lícované diery Ø12 F7 pre polohovanie

MNG

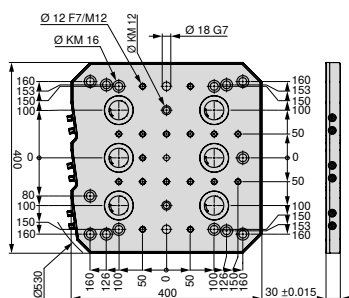

80 899 ...

EUR
Y44.510,00 63100¹⁾

Veľkosť	WT
400x400 mm	33

1) tovar nie je na sklade

Prehľad zverákov

Systémové príslušenstvo

144+145 Obecné príslušenstvo

164–183

MNG – 6násobná základná doska, 400 x 530 mm

- ▲ MNG – Mechanický upínací systém s nulovým bodom
- ▲ nehrdzavejúce a kalené vo vákuu
- ▲ vŕhovácia sila 20 kN u upínacieho čapu
- ▲ 24 x montážne otvory pre M12, pre vzdialenosť T-drážok 63, 100, 125 mm
- ▲ 21 x lícované diery Ø12 F7/M12
- ▲ 2 x lícované diery Ø18 G7 pre polohovanie
- ▲ 1 x lícované diery Ø12 F7 pre polohovanie

MNG

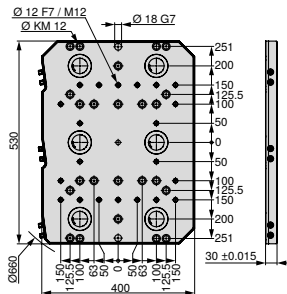

80 899 ...

EUR
Y44.880,00 63200¹⁾

Veľkosť	WT
400x530 mm	45

1) tovar nie je na sklade

MNG – 10násobná základná doska, 496,5 x 532 mm

- ▲ MNG – Mechanický upínací systém s nulovým bodom
- ▲ nehrdzavejúce a kalené vo vákuu
- ▲ vŕhovácia sila 20 kN u upínacieho čapu
- ▲ 27 x montážne otvory M12, pre vzdialenosť T-drážok 50, 63, 100, 125 mm a hviezdicové drážky 45°
- ▲ 20 x lícované diery Ø12 F7/M12
- ▲ 2 x lícované diery Ø18 G7 pre polohovanie
- ▲ 1 x lícované diery Ø12 F7 pre polohovanie

MNG

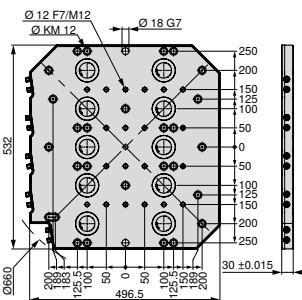

80 899 ...

EUR
Y46.930,00 63300¹⁾

Veľkosť	WT
497x532 mm	54

1) tovar nie je na sklade

Prehľad zverákov

Systémové príslušenstvo

144+145 Obecné príslušenstvo

164–183

MNG – Strediaci čap

▲ MNG – Mechanický upínací systém s nulovým bodom

MNG

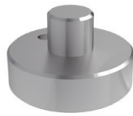

80 899 ...

D ₁ h6 mm	D ₂ h6 mm	EUR Y4	
12	30	74,00	61700
12	32	73,50	61800
12	50	39,00	61900

MNG – Vyrovnávací čap

▲ MNG – Mechanický upínací systém s nulovým bodom

MNG



80 899 ...

D ₁ h6 mm	D ₂ h6 mm	EUR Y4	
18	14	46,50	607
18	18	46,50	608
18	20	61,50	609
18	22	61,50	610

MNG –
Súprava upínacích skrutiek k T-drážke

▲ MNG – Mechanický upínací systém s nulovým bodom

Rozsah dodávky:

Upínacia skrutka a kameň do T drážky

MNG



80 899 ...

Pre šírku drážky mm	G	EUR Y4	
12	M8	31,10	63800
12	M10	11,50	63400
14	M8	31,10	63900
14	M12	13,80	63500 ¹⁾
16	M8	31,10	64000
16	M12	13,80	63600 ¹⁾
18	M8	31,10	64100
18	M12	13,80	63700 ¹⁾

1) So skrutkami s nízkou hlavou

MNG – Konzola vr. upínacieho modulu s nulovým bodom

- ▲ MNG – Mechanický upínací systém s nulovým bodom
- ▲ možnosť univerzálneho použitia na stoloch všetkých strojov
- ▲ ťahová sila 20 kN
- ▲ dotahovací moment 30 Nm
- ▲ materiál konzoly: tvrdo eloxovaný hliník

Rozsah dodávky:

Konzola vrátane kruhového upínacieho modulu MNG

MNG

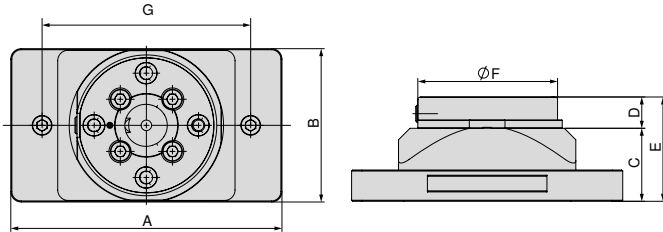

A	B	C	D	E	F	G	WT
mm	mm	mm	mm	mm	mm	mm	kg
260	147	70	30	100	135	200	8,9

80 899 ...

EUR
Y4

1.080,00 425

MNG – Konzola

- ▲ MNG – Mechanický upínací systém s nulovým bodom
- ▲ možnosť univerzálneho použitia na stoloch všetkých strojov
- ▲ materiál konzoly: tvrdo eloxovaný hliník

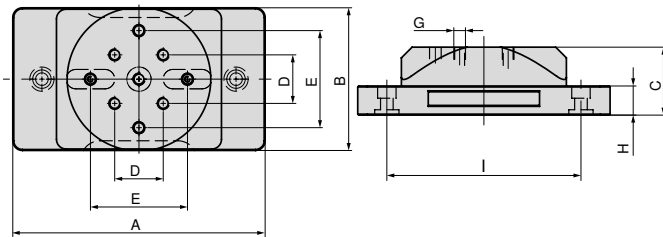

A	B	C	D	E _{±0,02}	G	H	I	WT
mm	mm	mm	mm	mm	M12	mm	mm	kg
260	147	70	50	100	M12	30	200	5,5

80 899 ...

EUR
Y4

519,00 420

Prehľad zverákov

Systémové príslušenstvo

144+145

Obecné príslušenstvo

164–183

MNG – 2násobná konzola s upínacím modulom a nulovými bodmi

- ▲ MNG – Mechanický upínací systém s nulovým bodom
- ▲ univerzálne použitie na všetkých strojných stoloch
- ▲ vŕhacová sila 20 kN u upínacieho čapu
- ▲ moment dotiahovania 30 Nm
- ▲ materiál konzoly: tvrdo eloxovaný hliník

Rozsah dodávky:

Konzola vrátane guľatého upínacieho modulu MNG

MNG

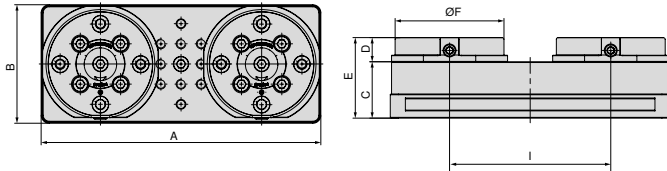

A	B	C	D	E	F	I	WT
mm	mm	mm	mm	mm	mm	mm	kg
347	147	70	30	100	135	200	16,5

80 899 ...

EUR
Y4

1.950,00 435

MNG – 2násobná konzola

- ▲ MNG – Mechanický upínací systém s nulovým bodom
- ▲ univerzálne použitie na všetkých strojných stoloch
- ▲ vŕhacová sila 20 kN u upínacieho čapu
- ▲ moment dotiahovania 30 Nm
- ▲ materiál konzoly: tvrdo eloxovaný hliník

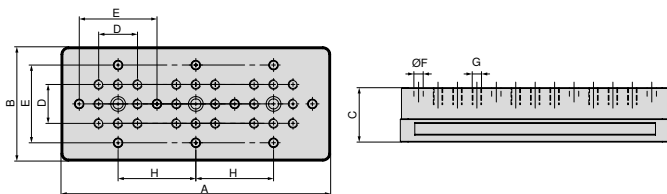

A	B	C	D	E _{±0,02}	F _{F7}	G	H	WT
mm	mm	mm	mm	mm	mm	M12	mm	kg
347	147	70	50	100	12	M12	100	9,3

80 899 ...

EUR
Y4

709,00 430

Prehľad zverákov

Systémové príslušenstvo

144+145

Obecné príslušenstvo

164–183

MNG – Konzola vr. upínacieho modulu s nulovým bodom

▲ MNG – Mechanický upínací systém s nulovým bodom

MNG

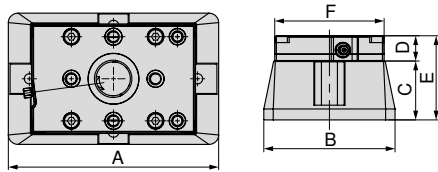

A	B	C	D	E	F
mm	mm	mm	mm	mm	mm
250	156	70	30	100	130

80 878 ...

EUR
Y4
1.300,00 54000

Konzola

▲ MNG – Mechanický upínací systém s nulovým bodom

ZSG
4

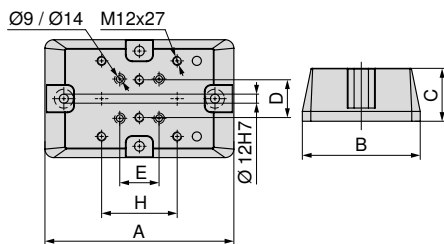

A	B	C	D	E	H	Pre
mm	mm	mm	mm	mm	mm	
250	156	70	50	52	100	ZSG 4 - 80 L = 130 mm + 190 mm / ZSG 4 - 125 L = 160 mm
320	197	100	50	50	100	ZSG 4 - 160 L = 280 mm
340	162	100	50	50	100	ZSG 4 - 125 L = 235 mm / 300 mm

80 878 ...

EUR
Y4
573,00 54100
903,00 54400
900,00 54300

MNG – Montážna sada pre konzolu

▲ MNG – Mechanický upínací systém s nulovým bodom



Pre
ZSG-4.125/160.L235-L280
ZSG-4.80.L130-L190

80 878 ...

EUR
Y4
11,30 54500
11,30 54200

Prehľad zverákov

Systémové príslušenstvo

144+145 Obecné príslušenstvo

164-183

MNG – Hliníková tvarová klieština

- ▲ MNG – Mechanický upínací systém s nulovým bodom
- ▲ pre upnutie a opracovávanie tvarových obrobkov

Rozsah dodávky:

Klieština s polohovacími kolíkmi, bez upínacieho čapu MNG

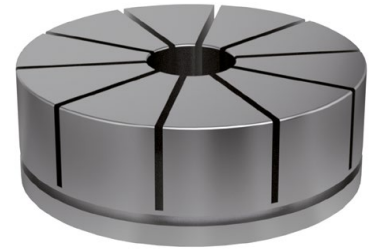
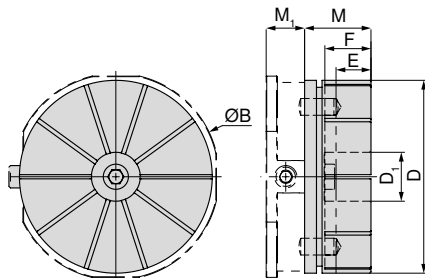

B	D	D ₁	E	F	M	M ₁
mm	mm	mm	mm	mm	mm	mm
148	138	35	22	33	47,5	27,5

80 899 ...

EUR
Y4

240,00 500



Hliníková klieština so zapracovaným tvarom obrobku na kruhový MNG



Hliníková klieština s upnutým obrobkom na kruhový MNG

Dodávame na požiadanie



Dierovaná rastrová paleta



Plná paleta

 Maximálna hĺbka vyfrézovania E činí 22 mm

Nastavovací krúžok pre tvarovú klieštinu MNG

MNG



80 899 ...

EUR
Y4

58,30 510

Prehľad zverákov

Systémové príslušenstvo

144+145

Obecné príslušenstvo

164–183

MNG – Upínací čap

▲ MNG – Mechanický upínací systém s nulovým bodom

Rozsah dodávky:

Vr. upínacích skrutiek M10 a M12

MNG

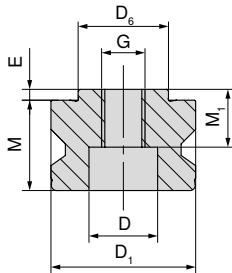

D ₆ h6	D ₁ h6	M	M ₁	E	D	G
mm	mm	mm	mm	mm	mm	M12
25	40	27	17	3	19	M12

80 899 ...

EUR

Y4

48,60 025

MNG – Záslepka

▲ MNG – Mechanický upínací systém s nulovým bodom

MNG

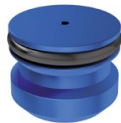

80 899 ...

EUR

Y4

14,30 040

D₁

mm

40

MNG – Súprava valcových kolíkov

▲ MNG – Mechanický upínací systém s nulovým bodom

▲ pre vežu ESG mini 4V a priame upnutie obrobku

▲ cena za 2 kusy

MNG



80 899 ...

EUR

Y4

2,40 120

D₁ m6

mm

12

M

mm

24

MNG – Záslepka s O-krúžkom

▲ MNG – Mechanický upínací systém s nulovým bodom

MNG



80 899 ...

EUR

Y4

2,40 126

G

M12

MNG – Súprava polohovacích kolíkov

▲ MNG – Mechanický upínací systém s nulovým bodom

▲ pre ESG mini a priame upnutie obrobku

▲ cena za 2 kusy

MNG

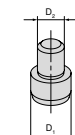

80 899 ...

EUR

Y4

34,70 128

Pre šírku

mm

65

D₁

mm

12

D₂

mm

8

MNG – Aretačný čap

▲ MNG – Mechanický upínací systém s nulovým bodom

MNG

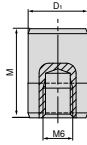

D ₁ mm	M mm
12	18

80 899 ...
EUR
Y4
17,30 51500

MNG – Súprava upínacích skrutiek k T-drážke

▲ MNG – Mechanický upínací systém s nulovým bodom

Rozsah dodávky:

Upínacia skrutka a kameň do T drážky

MNG



Pre šírku drážky mm	G	EUR Y4	80 899 ...
12	M8	31,10	63800
12	M10	11,50	63400
14	M8	31,10	63900
14	M12	13,80	63500 ¹⁾
16	M8	31,10	64000
16	M12	13,80	63600 ¹⁾
18	M8	31,10	64100
18	M12	13,80	63700 ¹⁾

1) So skrutkami s nízkou hlavou

MNG – Upínacia súprava pre T-drážku 14 mm

▲ MNG – Mechanický upínací systém s nulovým bodom

▲ kamene do T-drážok sú modifikované na vzdialenosť drážok 63 mm

▲ cena za 2 kusy

MNG



Pre šírku drážky mm	A mm
14	63

80 899 ...
EUR
Y4
96,10 614

MNG – Súprava na vyrovnávanie/centrovanie T-drážok

▲ MNG – Mechanický upínací systém s nulovým bodom

▲ A = Rozteč otvorení

Rozsah dodávky:

1 upínacia lišta, 2 kamene do T drážok, 2 skrutky,
2 podložky pre šírku 12 mm, bez upínacej lišty

MNG



A mm	Pre šírku drážky mm	EUR Y4	80 899 ...
50	12	71,30	012 ¹⁾
50	14	71,30	014
50	16	71,30	016
50	18	71,30	018
100	12	93,90	81200
100	14	93,90	81400
100	16	93,90	81600
100	18	93,90	81800

1) Pre šírku 12 mm bez upínacej lišty

MNG – Kruhovú pätku

▲ MNG – Mechanický upínací systém s nulovým bodom

▲ cena za 2 kusy

MNG



80 899 ...
EUR
Y4
81,00 300

MNG – Náhradná upínacia jednotka

▲ MNG – Mechanický upínací systém s nulovým bodom

▲ 3dielna súprava

▲ pre kruhovú dosku MNG

MNG



80 899 ...
EUR
Y4
126,00 026

MNG

Možnosti upínania pomocou systému MNG

MNG – Hranatá základná doska

Pripevnenie:

- 2 x Skrutky s nízkou hlavou M12
- 1 x Súprava pre vyrovnávanie a stredenie

→ Strana 148
Vhodné upínacie skrutky pre MNG.

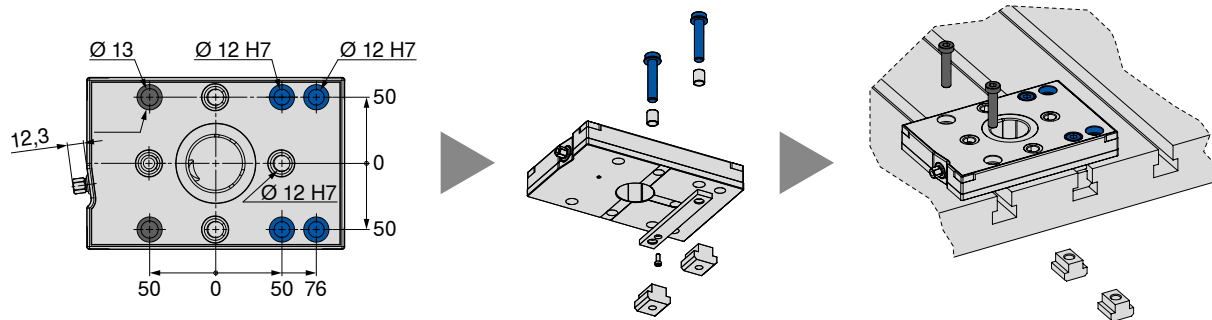

MNG – Hranatá základná doska, 2násobná

Pripevnenie:

- 4 x Skrutky s nízkou hlavou M12
- 1 x Súprava pre vyrovnávanie a stredenie
- 4 x Špeciálne skrutky M8-MNG

→ Strana 148
Vhodné upínacie skrutky pre MNG.

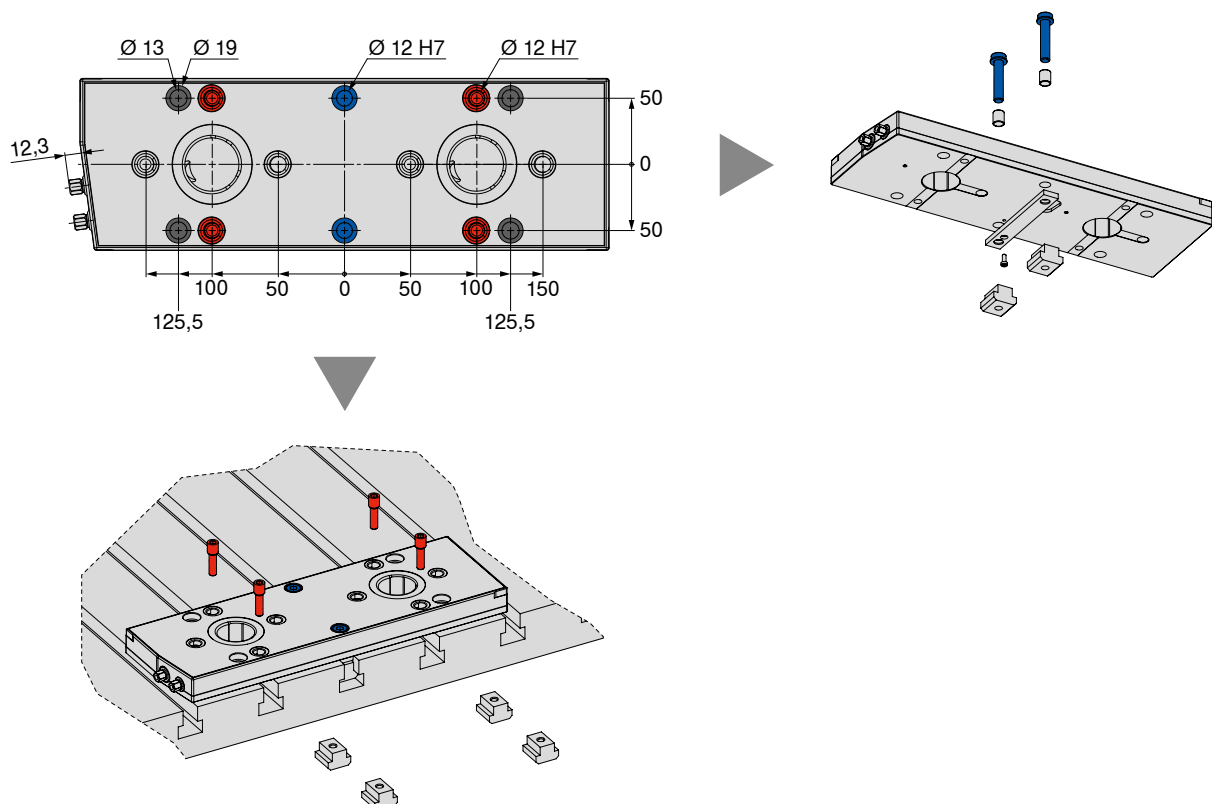

Možnosti upínania pomocou systému MNG

MNG – Hranatá základná doska, 3násobná

Pripevnenie:

- 5 x Skrutky s nízkou hlavou M12
- 1 x Súprava pre vyrovnávanie a stredenie
- 5 x Špeciálne skrutky M8-MNG



→ Strana 148
Vhodné upínacie skrutky pre MNG.

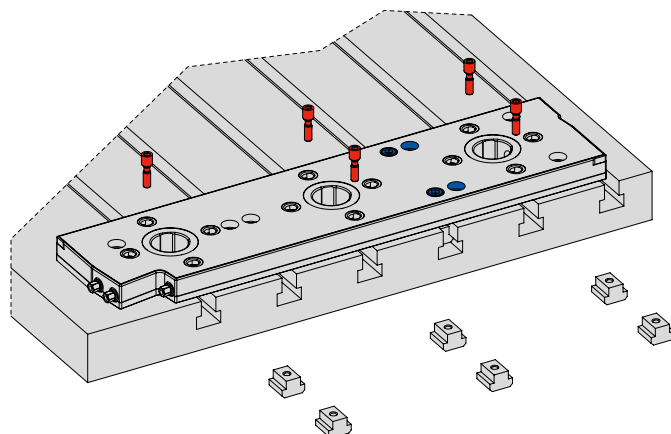
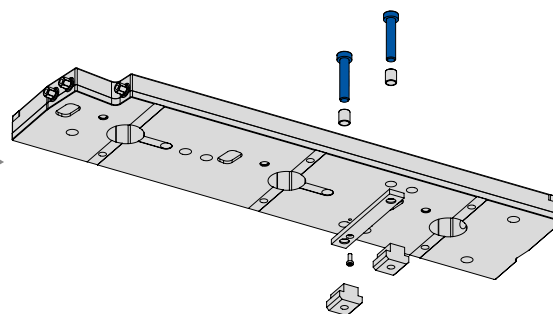
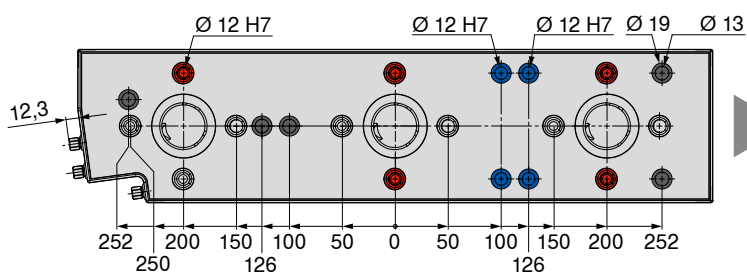

Možnosti upínania pomocou systému MNG

Stôl s T drážkou – rázvor 126 mm / 63 mm												
	12 mm			14 mm			16 mm			18 mm		
	●	●	●	●	●	●	●	●	●	●	●	●
	Súprava pre vyrovnávanie a stredenie, rázvor 100 mm 80 899 81200			Súprava pre vyrovnávanie a stredenie, rázvor 100 mm 80 899 81400			Súprava pre vyrovnávanie a stredenie, rázvor 100 mm 80 899 81600			Súprava pre vyrovnávanie a stredenie, rázvor 100 mm 80 899 81800		
	Upínacia súprava so skrutkami s nízkou hlavou M10 80 899 63400			Upínacia súprava so skrutkami s nízkou hlavou M12 80 899 63500			Upínacia súprava so skrutkami s nízkou hlavou M12 80 899 63600			Upínacia súprava so skrutkami s nízkou hlavou M12 80 899 63700		
	Upínacia súprava so špeciálnymi skrutkami M8-MNG 80 899 63800			Upínacia súprava so špeciálnymi skrutkami M8-MNG 80 899 63900			Upínacia súprava so špeciálnymi skrutkami M8-MNG 80 899 64000			Upínacia súprava so špeciálnymi skrutkami M8-MNG 80 899 64100		
MNG – Hranatá základná doska	1 x	2 x	—	1 x	2 x	—	1 x	2 x	—	1 x	2 x	—
MNG – Hranatá základná doska, 2násobná	1 x	4 x	—	1 x	4 x	—	1 x	4 x	—	1 x	4 x	—
MNG – Hranatá základná doska, 3násobná	1 x	4 x	2 x	1 x	4 x	2 x	1 x	4 x	2 x	1 x	4 x	2 x

Stôl s T drážkou – rázvor 100 mm / 50 mm												
	12 mm			14 mm			16 mm			18 mm		
	●	●	●	●	●	●	●	●	●	●	●	●
	Súprava pre vyrovnávanie a stredenie, rázvor 100 mm 80 899 81200			Súprava pre vyrovnávanie a stredenie, rázvor 100 mm 80 899 81400			Súprava pre vyrovnávanie a stredenie, rázvor 100 mm 80 899 81600			Súprava pre vyrovnávanie a stredenie, rázvor 100 mm 80 899 81800		
	Upínacia súprava so skrutkami s nízkou hlavou M10 80 899 63400			Upínacia súprava so skrutkami s nízkou hlavou M12 80 899 63500			Upínacia súprava so skrutkami s nízkou hlavou M12 80 899 63600			Upínacia súprava so skrutkami s nízkou hlavou M12 80 899 63700		
	Upínacia súprava so špeciálnymi skrutkami M8-MNG 80 899 63800			Upínacia súprava so špeciálnymi skrutkami M8-MNG 80 899 63900			Upínacia súprava so špeciálnymi skrutkami M8-MNG 80 899 64000			Upínacia súprava so špeciálnymi skrutkami M8-MNG 80 899 64100		
MNG – Hranatá základná doska	1 x	2 x	—	1 x	2 x	—	1 x	2 x	—	1 x	2 x	—
MNG – Hranatá základná doska, 2násobná	1 x	—	4 x	1 x	—	4 x	1 x	—	4 x	1 x	—	4 x
MNG – Hranatá základná doska, 3násobná	1 x	1 x	5 x	1 x	1 x	5 x	1 x	1 x	5 x	1 x	1 x	5 x

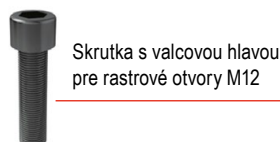
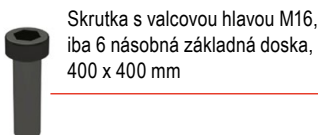
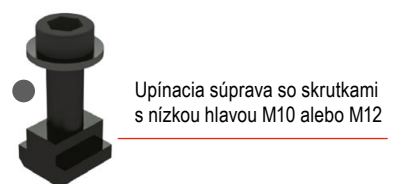

→ Strana 145
→ Strana 182+183
Tu nájdete položky uvedené vyššie.

MNG mini – Konzola

- ▲ s integrovaným upínacím systémom s nulovým bodom MNG mini
- ▲ upínacie čapy objednávajte samostatne
- ▲ materiál: tvrdo eloxovaný hliník

MNG mini

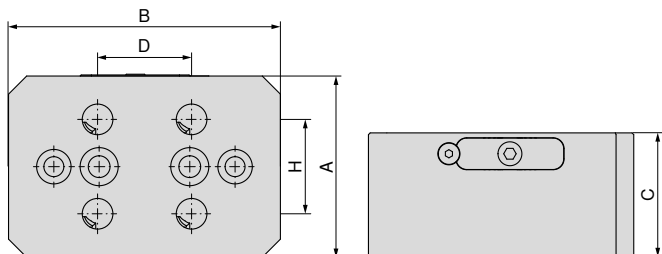

NEW

80 915 ...

EUR
Y4

770,00 57000

A	B	C	D	H
mm	mm	mm	mm	mm
100	150	70	52	52

MNG mini – 3 násobná pyramída

- ▲ vr. 3 x upínací systém s nulovým bodom MNG mini
- ▲ upínacie čapy objednávajte samostatne
- ▲ materiál: tvrdo eloxovaný hliník

MNG mini

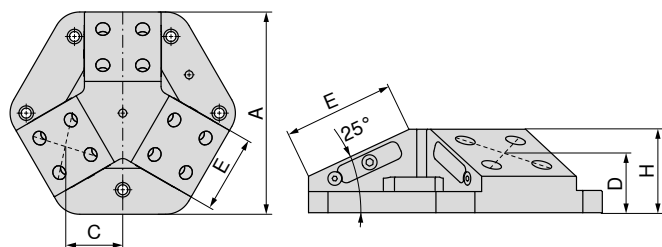

NEW

80 915 ...

EUR
Y4

1.980,00 58000

A	C	D	E	H
mm	mm	mm	mm	mm
264	86,68	53,87	100	75

 Vhodný pre: ESG 5 – 80 L-130 / ZSG 4 – 80 L-130 / ZSG mini – 70 L-80 / ZSG mini – 70 L-100

Rozmery spodnej strany zveráka MNG mini

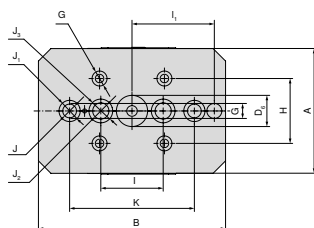

Konzola

A	B	D ₆ H7	G H7	H	I	I ₁ ±0,015	J	J ₁	J ₂	J ₃	K ±0,015
mm	mm	mm	mm	mm	mm	mm	mm	mm	mm	mm	mm
100	150	25	12	52	50	66	11	17	13	19	100

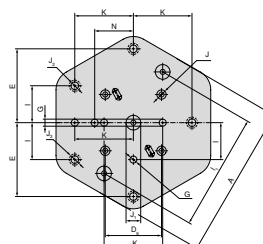

3 násobná pyramída

A	D ₆ ±0,015	E	G H7	I	I ₁ ±0,015	J H7	J ₁ H7	J ₂	J ₃	K	N ±0,015
mm	mm	mm	mm	mm	mm	mm	mm	mm	mm	mm	mm
264	96	126	12	63	200	16	25	13	19	100	66

MNG mini – 4 násobná pyramída

- ▲ vr. 4 x upínací systém s nulovým bodom MNG mini
- ▲ upínacie čapy objednávajte samostatne
- ▲ materiál: tvrdo eloxovaný hliník

MNG mini

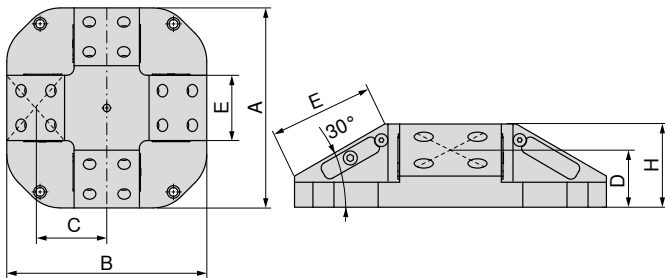

NEW

80 915 ...

EUR
Y4

2.390,00 57500

A	B	C	D	E	H
mm	mm	mm	mm	mm	mm
300	300	106,7	55	100	80

MNG mini – Trojuholníková veža

- ▲ vr. 3 x upínací systém s nulovým bodom MNG mini
- ▲ upínacie čapy objednávajte samostatne
- ▲ materiál: tvrdo eloxovaný hliník

MNG mini

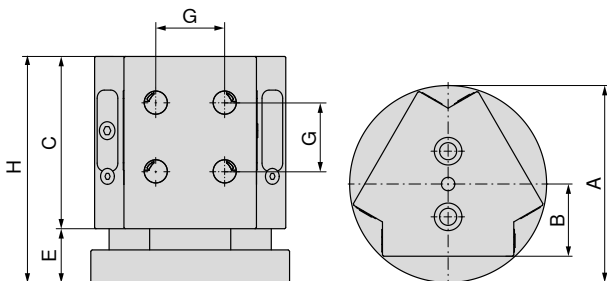

NEW

80 915 ...

EUR
Y4

1.490,00 51700

A	B	C	E	G	H
mm	mm	mm	mm	mm	mm
148	55	130	41	52	171

 Vhodný pre: ESG 5 – 80 L-130 / ZSG 4 – 80 L-130 / ZSG mini – 70 L-80 / ZSG mini – 70 L-100

Rozmery spodnej strany zveráka MNG mini

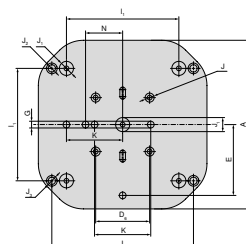

4 násobná pyramída

A	D ₆ ±0.015	E	G _{H7}	I	I ₁ ±0.015	J _{H7}	J _{1H7}	J ₂	J ₃	K ±0.015	N ±0.015
mm	mm	mm	mm	mm	mm	mm	mm	mm	mm	mm	mm
300	96	126	12	252	200	16	25	13	19	100	66

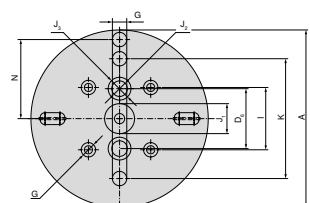

Trojuholníková veža

A	D ₆	G _{H7}	I ±0.015	J _{1H7}	J ₂	J ₃	K ±0.015	N ±0.015
mm	mm	mm	mm	mm	mm	mm	mm	mm
148	50	12	52	25	13	19	100	66

Súprava upínacích čapov MNG mini

Rozsah dodávky:

Súprava obsahuje štyri upínacie čapy

**MNG
mini**

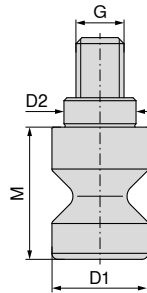

NEW

80 915 ...

EUR
Y4

67,00 51600

D ₁ h6 mm	D ₂ h6 mm	M	G	TQX Nm	Prídržná sila kN
16	12	22	M8	18	15

Súprava upínacích skrutiek k T-drážke pre MNG mini

Rozsah dodávky:

Upínacia skrutka a kameň do T drážky

**MNG
mini**



NEW

80 915 ...

EUR
Y4

Pre šírku drážky mm	G	EUR Y4
12	M10	16,70 61200
14	M12	16,70 61400
16	M12	17,90 61600
18	M12	19,00 61800

Súprava na vyrovnávanie/centrovanie T-drážok

▲ MNG – Mechanický upínací systém s nulovým bodom

▲ A = Rozteč otvorení

Rozsah dodávky:

1 upínacia lišta, 2 kamene do T drážok, 2 skrutky, 2 podložky pre šírku 12 mm, bez upínacej lišty

**MNG
mini**



NEW

80 915 ...

EUR
Y4

A mm	Pre šírku drážky mm	EUR Y4
100	12	90,70 81200
100	14	90,70 81400
100	16	90,70 81600
100	18	90,70 81800

PNG – Upínacia stanica – 1násobná, 198 x 150 mm

- ▲ PNG – Pneumatický upínací systém s nulovým bodom
- ▲ vťahovacia sila 8 kN
- ▲ vťahovacia sila s Turbo 28 kN
- ▲ odisťovací tlak 6 barov
- ▲ vzduchová prípojka G 1/8

Rozsah dodávky:

Upínacia stanica, úpinky, uzatváracia vsuvka, pneumatické prípojky, záslepky, návod na obsluhu; bez upínacích čapov, bez aretačných čapov

PNG

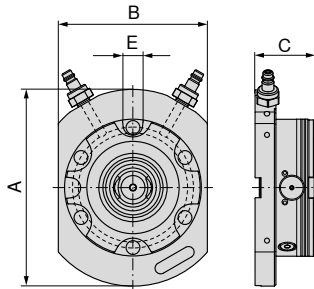

A	B	C	E _{H7}	WT
mm	mm	mm	mm	kg
198	150	60	20	7

80 809 ...

EUR
Y4

1.500,00 01100

PNG – Upínacia stanica – 2násobná, 399 x 199 mm

- ▲ PNG – Pneumatický upínací systém s nulovým bodom
- ▲ vťahovacia sila 16 kN
- ▲ odisťovací tlak 6 barov
- ▲ vzduchová prípojka G 1/8

Rozsah dodávky:

Upínacia stanica, úpinky, uzatváracia vsuvka, pneumatické prípojky, záslepky, návod na obsluhu; bez upínacích čapov, bez aretačných čapov

PNG

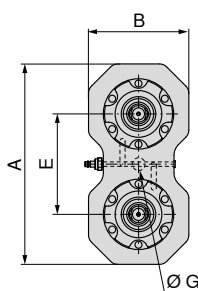

A	B	C	E	G _{H7}	WT
mm	mm	mm	mm	mm	kg
399	199	60	200	25	16,9

80 809 ...

EUR
Y4

2.400,00 02100

PNG – Upínacia stanica – 4násobná, 399 x 399 mm

- ▲ PNG – Pneumatický upínací systém s nulovým bodom
- ▲ vŕahovacia sila 32 kN
- ▲ odisťovací tlak 6 barov
- ▲ vzduchová prípojka G 1/8

Rozsah dodávky:

Upínacia stanica, úpinky, uzatváracia vsuvka, pneumatické prípojky, záslepky, návod na obsluhu; bez upínacích čapov, bez aretačných čapov

PNG

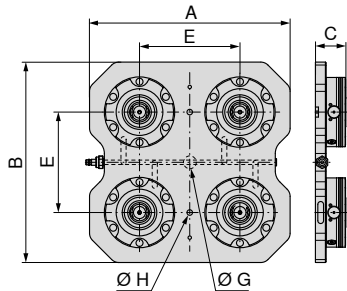

A	B	C	E	G _{H7}	H	WT
mm	mm	mm	mm	mm	mm	kg
399	399	60	200	25	11	35,7

80 809 ...

EUR
Y4

4.630,00 04100

PNG – Upínacia stanica – 6násobná, 599 x 399 mm

- ▲ PNG – Pneumatický upínací systém s nulovým bodom
- ▲ vŕahovacia sila 48 kN
- ▲ odisťovací tlak 6 barov
- ▲ vzduchová prípojka G 1/8

Rozsah dodávky:

Upínacia stanica, úpinky, uzatváracia vsuvka, pneumatické prípojky, záslepky, návod na obsluhu; bez upínacích čapov, bez aretačných čapov

PNG

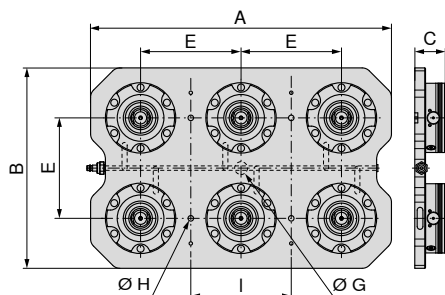

A	B	C	E	G _{H7}	H	I	WT
mm	mm	mm	mm	mm	mm	mm	kg
599	399	60	200	25	11	200	54,4

80 809 ...

EUR
Y4

6.240,00 06100

PNG – Upínací modul s nulovým bodom PNG.SM.138

- ▲ PNG – Pneumatický upínací systém s nulovým bodom
- ▲ vťahovacia sila 8 kN
- ▲ vťahovacia sila s Turbo 28 kN
- ▲ odist'ovací tlak 6 barov
- ▲ vzduchová prípojka G 1/8
- ▲ presnosť opakovania 0,005

Rozsah dodávky:

Upínací modul, upínacie skrutky, o-krúžky, záslepky, návod na obsluhu; bez upínacích čapov

PNG

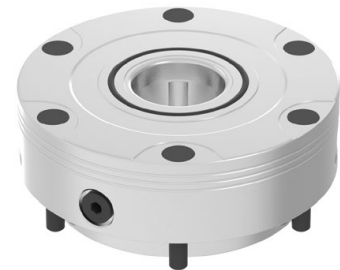
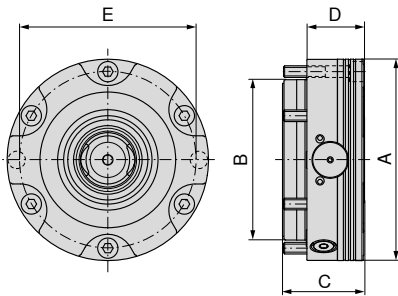

A	B	C	D	E	G	WT
mm	mm	mm	mm	mm		kg
138	110	55,7	39	121	G1/8"	4,4

80 809 ...

EUR

Y4

954,00 10100

PNG – Upínací systém s nulovým bodom PNG.SM.T.138

- ▲ PNG – Pneumatický upínací systém s nulovým bodom
- ▲ vťahovacia sila 7 kN
- ▲ vťahovacia sila s Turbo 24 kN
- ▲ odist'ovací tlak 6 barov
- ▲ vzduchová prípojka G 1/8
- ▲ presnosť opakovania 0,005

Rozsah dodávky:

Upínací modul, upínacie skrutky, o-krúžky, záslepky, návod na obsluhu; bez upínacích čapov

PNG

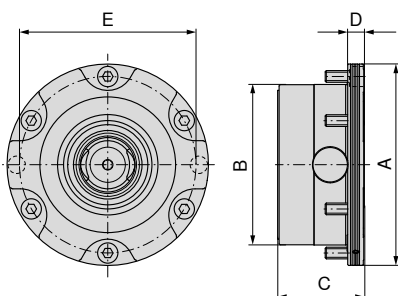

A	B	C	D	E	G	WT
mm	mm	mm	mm	mm		kg
138	110	59	11	121	G1/8"	3,5

80 809 ...

EUR

Y4

1.040,00 12100

PNG – Upínací modul s nulovým bodom PNG.SM.V.138

- ▲ PNG – Pneumatický upínací systém s nulovým bodom
- ▲ vťahovacia sila 8 kN
- ▲ vťahovacia sila s Turbo 28 kN
- ▲ odšťavovací tlak 6 barov
- ▲ vzduchová prípojka G 1/8
- ▲ presnosť opakovania 0,005

Rozsah dodávky:

Upínací modul, upínacie skrutky, lícovaná skrutka, o-krúžky, záslepky, návod na obsluhu; bez upínacích čapov, bez aretačných čapov

PNG

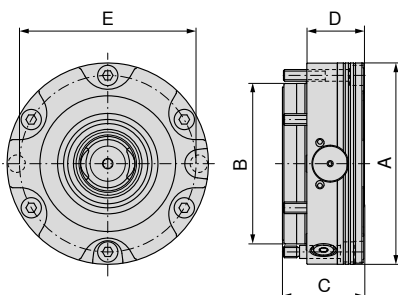

A	B	C	D	E	G	WT
mm	mm	mm	mm	mm		kg
138	110	55,7	39	121	G1/8"	4,4

80 809 ...

EUR
Y4

1.020,00 11100

PNG – Hliníková tvarová klieština pre PNG

- ▲ PNG – Pneumatický upínací systém s nulovým bodom
- ▲ max. upínacia sila 50 kN
- ▲ presnosť opakovania 0,005
- ▲ upínací zdvih 0,5 mm
- ▲ materiál – hliník

Rozsah dodávky:

Hliníková tvarová klieština, nastavovací krúžok, upínací čap, aretačný čap, návod na obsluhu

PNG

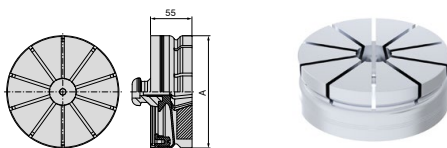

80 809 ...

A	WT
mm	kg
149	1,5

EUR
Y4

324,00 07600

PNG – Aretačný čap

- ▲ PNG – Pneumatický upínací systém s nulovým bodom

PNG

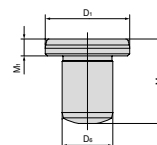

80 809 ...

D ₁ h5	M	M ₁	D ₃ m6
mm	mm	mm	mm
20	20	4	12

EUR
Y4

52,30 073

Montáž pomocou upínacích čapov

Upínané obrobky alebo zariadenia sa polohujú a fixujú pomocou troch rôznych upínacích čapov:



Strediacie čapy
Precízne brúsený pre presné polohovanie upínaného prípravku.

Polohovacie čapy
Tento čap, označovaný taktiež ako diamantový čap, sa brúsi iba v časti obvodu v jednej osi, aby nedochádzalo k preťaženiu systému.

Upínacie čapy
Zaisťuje iba upnutie prípravku po celej ploche, je brúsený s vňou.

PNG – Upínací čap

- ▲ PNG – Pneumatický upínací systém s nulovým bodom
- ▲ 3 typy čapov – strediaci čap ZB, polohovací čap PB, pridrzný čap HB
- ▲ veľmi presné prispôsobenie rozmerov danej funkcii
- ▲ pridrzná sila 50 kN

Rozsah dodávky:

Vr. upínacej skrutky M10

PNG

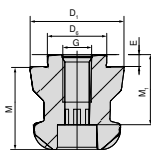

80 809 ...

Typ	D ₆ h6 mm	D ₁ h6 mm	M mm	M ₁ mm	E mm	G	EUR Y4	
ZB	25	40	35	27	5	M12	57,40	070
PB	25	40	35	27	5	M12	69,10	071
HB	25	40	35	27	5	M12	52,10	072

PNG – Kužeľové tesnenie PNG

- ▲ PNG – Pneumatický upínací systém s nulovým bodom
- ▲ ochranný kryt na ochranu upínacieho modulu

PNG

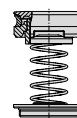

80 809 ...

WT
kg
0,11

EUR
Y4
121,00 07500

PNG – Zátka

- ▲ PNG – Pneumatický upínací systém s nulovým bodom
- ▲ ochranný kryt na ochranu upínacieho modulu

PNG

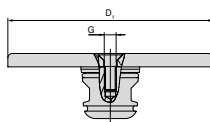

80 809 ...

D ₁ mm	G	EUR Y4	
138	M8	94,90	074

Prehľad variabilných rastrových palet



Variabilná rastrová paleta 159 x 159 mm

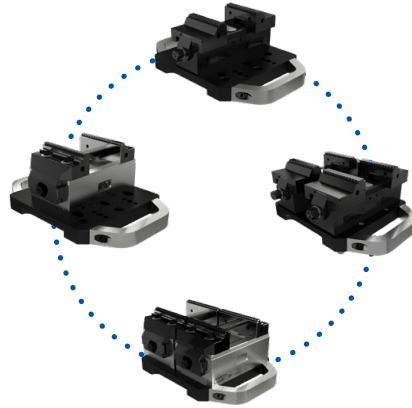

Príklady použitia

Variabilná rastrová paleta, 159 x 159 mm

▲ variabilná rastrová paleta pre pripevnenie na PNG a MNG

Rozsah dodávky:

Vr. upínacích skrutiek

Bez upínacích čapov pre nulové body

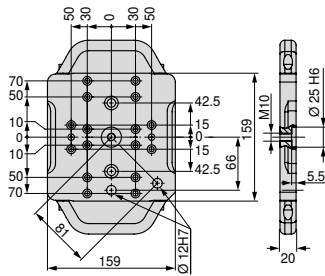

Veľkosť	WT
159x159 mm	4 kg

80 809 ...
EUR
Y4
502,00
500

Montážna súprava – variabilná rastrová paleta, 159 x 159 mm

▲ cena za súpravu



Pre
ZSG-4.80

80 878 ...
EUR
Y4
17,30
503

Prehľad variabilných rastrových palet



Variabilná rastrová paleta 399 x 159 mm

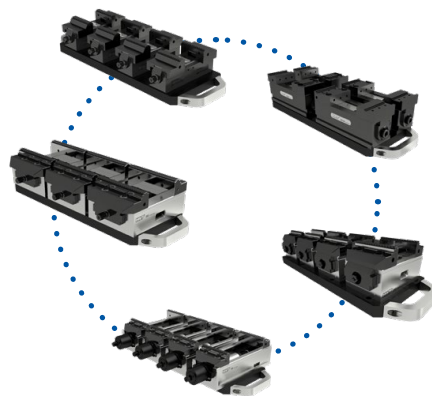

Príklady použitia

Variabilná rastrová paleta 399 x 159 mm

▲ variabilná rastrová paleta pre pripevnenie na PNG a MNG

Rozsah dodávky:

Vr. upínacích skrutiek, bez upínacích čapov pre nulové body

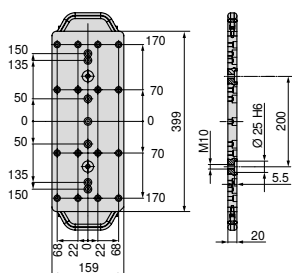

Veľkosť	WT
399x159 mm	10 kg

80 809 ...

EUR
Y4
737,00 501

Montážna súprava – variabilná rastrová paleta, 399 x 159 mm

▲ cena za súpravu



Pre
ZSG-3.65/ZSG-4.80/125L160/ESG-4.80

80 884 ...

EUR
Y4
39,00 503

Prehľad variabilných rastrových palet

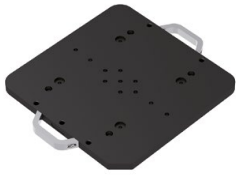

Variabilná rastrová paleta 399 x 399 mm

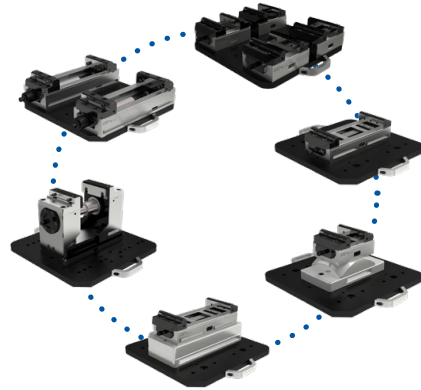

Príklady použitia

Variabilná rastrová paleta, 399 x 399 mm

▲ variabilná rastrová paleta pre pripevnenie na PNG a MNG

Rozsah dodávky:

Vr. upínacích skrutiek, bez upínacích čapov pre nulové body

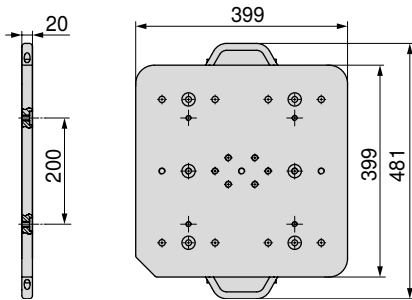

Veľkosť	WT	80 809 ...
399x399 mm	25 kg	EUR Y4 1.380,00 502

Montážna súprava – variabilná rastrová paleta, 399 x 399 mm

▲ cena za súpravu



Pre	80 901 ...	80 898 ...	80 878 ...
	EUR Y4	EUR Y4	EUR Y4
ESG4.125	55,10 500		
H5G.125		55,10 500	
ZSG-4.125.L160			17,30 500
ZSG-4.125.L160.K			55,10 502
ZSG-4.125.L300			55,10 501
ZSG-4.125.L300-DK			55,10 504

Upínacia oceľová paleta, 159 x 159 mm

- ▲ upínacia paleta pre pripevnenie na PNG
- ▲ bez vŕtaných otvorov

Rozsah dodávky:

Neobrobená upínacia paleta, upínací čap PNG a polohovací kolík

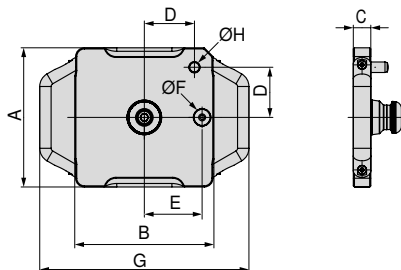

Veľkosť	A	B	C	D	E	F _{H5}	G	H _{m6}	WT
	mm	mm	mm	mm	mm	mm	mm	mm	kg
159x159 mm	159	159	20	58	66	20	239	12	4,2

80 809 ...

EUR
Y4

333,00 080

Upínacia hliníková paleta, 159 x 159 mm

- ▲ upínacia paleta pre pripevnenie na PNG
- ▲ bez vŕtaných otvorov

Rozsah dodávky:

Neobrobená upínacia paleta, upínací čap PNG a polohovací kolík

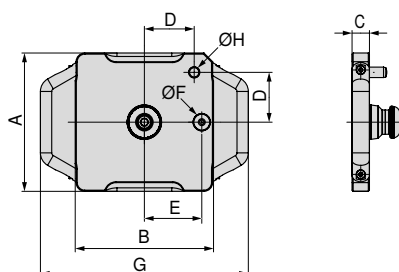

Veľkosť	A	B	C	D	E	F _{H5}	G	H _{m6}	WT
	mm	mm	mm	mm	mm	mm	mm	mm	kg
159x159 mm	159	159	25	58	66	20	239	12	2,2

80 809 ...

EUR
Y4

376,00 081

Upínacia oceľová paleta, 399 x 159 mm

- ▲ upínacia paleta pre pripevnenie na PNG a MNG
- ▲ bez vŕtaných otvorov

Rozsah dodávky:

Neobrobená upínacia paleta, upínací čap PNG a polohovací kolík

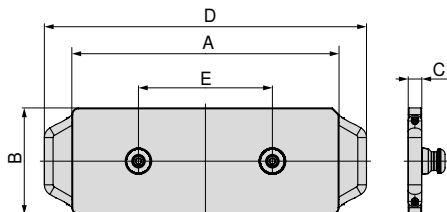

Veľkosť	A mm	B mm	C mm	D mm	E mm	WT kg
399x159 mm	399	159	20	481	200	10,6

80 809 ...

EUR
Y4

668,00 082

Upínacia hliníková paleta, 399 x 159 mm

- ▲ upínacia paleta pre pripevnenie na PNG a MNG
- ▲ bez vŕtaných otvorov

Rozsah dodávky:

Neobrobená upínacia paleta, upínací čap PNG a polohovací kolík

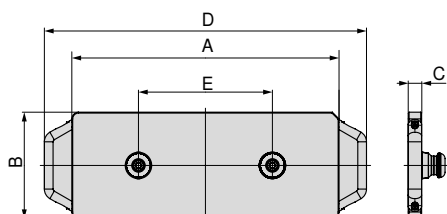

Veľkosť	A mm	B mm	C mm	D mm	E mm	WT kg
399x159 mm	399	159	25	481	200	5,1

80 809 ...

EUR
Y4

584,00 083

Upínacia oceľová paleta, 399 x 399 mm

- ▲ upínacia paleta pre pripevnenie na PNG a MNG
- ▲ bez vŕtaných otvorov

Rozsah dodávky:

Neobrobená upínacia paleta, upínací čap PNG a polohovací kolík

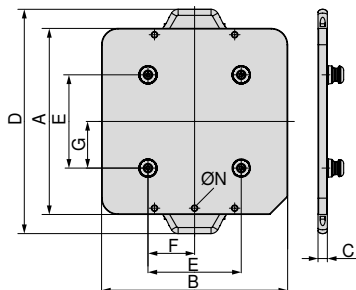

Veľkosť	A	B	C	D	E	F	G	N	WT
	mm	mm	mm	mm	mm	mm	mm	M10	kg
399x399 mm	399	399	20	481	200	100	100	M10	28

80 809 ...

EUR
Y4

1.460,00 084

Upínacia hliníková paleta, 399 x 399 mm

- ▲ upínacia paleta pre pripevnenie na PNG a MNG
- ▲ bez vŕtaných otvorov

Rozsah dodávky:

Neobrobená upínacia paleta, upínací čap PNG a polohovací kolík

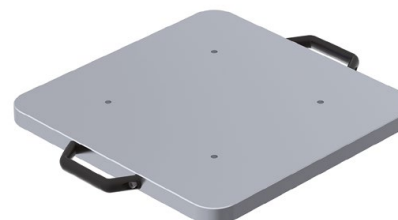
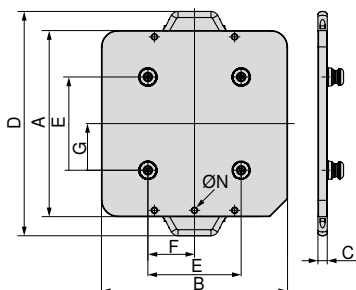

Veľkosť	A	B	C	D	E	F	G	N	WT
	mm	mm	mm	mm	mm	mm	mm	M10	kg
399x399 mm	399	399	25	481	200	100	100	M10	12

80 809 ...

EUR
Y4

1.070,00 085

Upínacia oceľová paleta, 599 x 159 mm

- ▲ upínacia paleta pre pripevnenie na PNG a MNG
- ▲ bez vŕtaných otvorov

Rozsah dodávky:

Neobrobená upínacia paleta, upínací čap PNG a polohovací kolík

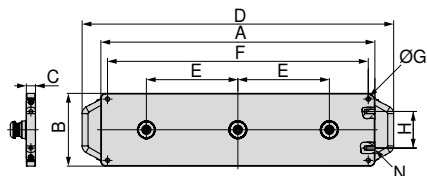

Veľkosť	A	B	C	D	E	F	G	H	N	WT
	mm	mm	mm	mm	mm	mm		mm		kg
599x159 mm	599	159	20	681	200	570	M10	80	M10	15,6

80 809 ...

EUR
Y4

936,00 086

Upínacia hliníková paleta, 599 x 159 mm

- ▲ upínacia paleta pre pripevnenie na PNG a MNG
- ▲ bez vŕtaných otvorov

Rozsah dodávky:

Neobrobená upínacia paleta, upínací čap PNG a polohovací kolík

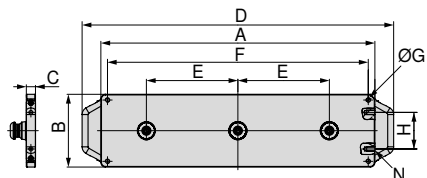

Veľkosť	A	B	C	D	E	F	G	H	N	WT
	mm	mm	mm	mm	mm	mm		mm		kg
599x159 mm	599	159	25	681	200	570	M10	80	M10	7,4

80 809 ...

EUR
Y4

1.020,00 087

Prehľad výmenných čeľustí všeobecne

Ďásobná otočná čeľusť

- ▲ 1 = hladká, s povlakom WC
- ▲ 2 = grip so stupňom 3 mm
- ▲ 3 = grip so stupňom 8 mm
- ▲ 4 = grip so stupňom 18 mm
- ▲ 5 = guľatý grip so stupňom 8 mm
- ▲ 6 = guľatý grip
- ▲ $M_{max} = 60 \text{ Nm}$
- ▲ vr. upínacej skrutky
- ▲ cena za kus

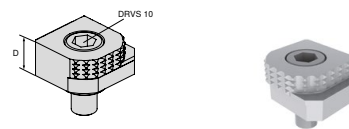

pre šírku zveráka	A	A ₁	D	D ₁	D ₂	E	M	M ₁	M ₂	EUR	Y4	NCG	H5G / -S / -Z	X5G-Z / -S	ESG 4	ESG 5	HDG 2	ZSG 4	ZSG mini	DSG 4	Verso	HSG	
			18							80,60	80 892 246	●	●	●	●			●	●	●	●	●	●

Ďásobná otočná čeľusť, karbid grip

- ▲ 1 = hladká
- ▲ 2 = karbidový grip
- ▲ 3 = karbidový grip so stupňom 3 mm
- ▲ 4 = karbidový grip so stupňom 8 mm
- ▲ 5 = karbidový guľatý grip so stupňom 8 mm
- ▲ 6 = karbidový guľatý grip
- ▲ vr. upínacej skrutky
- ▲ cena za kus

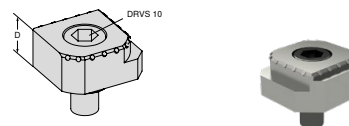

pre šírku zveráka	A	A ₁	D	D ₁	D ₂	E	M	M ₁	M ₂	EUR	Y4	NCG	H5G / -S / -Z	X5G-Z / -S	ESG 4	ESG 5	HDG 2	ZSG 4	ZSG mini	DSG 4	Verso	HSG	
			18							117,00	80 890 35300	●	●	●	●			●	●	●	●	●	●

Polohovacia lišta

- ▲ pre stupňovité čeľuste s T-drážkou
- ▲ rôznych upínacích hĺbok je možné docieľiť prefrézovaním
- ▲ po prefrézovaní lišty je možné použitie ako doraz
- ▲ materiál 1.7131, teda je ho možné v prípade potreby zakaliť
- ▲ cena za kus

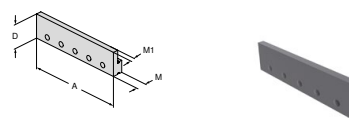

pre šírku zveráka	A	A ₁	D	D ₁	D ₂	E	M	M ₁	M ₂	EUR	Y4	NCG	H5G / -S / -Z	X5G-Z / -S	ESG 4	ESG 5	HDG 2	ZSG 4	ZSG mini	DSG 4	Verso	HSG	
	100		32				13,5	7		48,90	80 892 338	●	●	●	●			●	●	●	●	●	●
	125		32				13,5	7		51,30	80 892 339	●	●	●	●			●	●	●	●	●	●
	160		32				13,5	7		49,70	80 892 340	●	●	●	●			●	●	●	●	●	●

Prehľad výmenných čelustí všeobecne

Stupňovitá čelusť, grip s T-drážkou

- ▲ T-drážka pre upnutie polohovacej lišty
- ▲ vďaka styčnej ploche so šírkou 6,5 mm je vhodná na obrabky s hrubými hranami
- ▲ vylaserovaná stupnica (dieliky po 2 mm) ako pomôcka pre polohovanie
- ▲ cena za kus

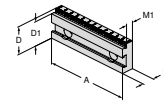

pre šírku zveráka	A	A ₁	D	D ₁	D ₂	E	M	M ₁	M ₂	EUR	Y4	NCG	H5G / -S / -Z	X5G-Z / -S	ESG 4	ESG 5	HDG 2	ZSG 4	ZSG mini	DSG 4	Verso	HSG	
100			35	32			17,5	11,5		131,00	80 892 341	●					●						●
100			35	30			17,5	11,5		131,00	80 892 342	●					●						●
100			35	27			17,5	11,5		131,00	80 892 343	●					●						●
125			40	37			17,5	11,5		142,00	80 892 344	●	●		●		●	●			●		●
125			40	35			17,5	11,5		141,00	80 892 345	●	●		●		●	●			●		●
125			40	32			17,5	11,5		141,00	80 892 346	●	●		●		●	●			●		●
160			50	45			20	13,5		158,00	80 892 348	●			●		●	●			●		●
160			50	42			20	13,5		158,00	80 892 349	●			●		●	●					●

Stupňovitá čelusť, 5 a 8 mm, hladká

- ▲ cena za kus

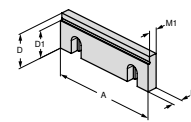

pre šírku zveráka	A	A ₁	D	D ₁	D ₂	E	M	M ₁	M ₂	EUR	Y4	NCG	H5G / -S / -Z	X5G-Z / -S	ESG 4	ESG 5	HDG 2	ZSG 4	ZSG mini	DSG 4	Verso	HSG	
100			35	30			10	7,5		86,40	80 892 21400	●					●						●
125			40	32			11,5	9,5		103,00	80 892 21500	●	●		●		●	●			●		●
160			50	42			13,5	10,5		186,00	80 892 21600	●			●		●	●			●		●

Stupňovitá čelusť, 3 mm, hladká

- ▲ je možné použiť ako hladkú čelusť alebo stupňovitú čelusť
- ▲ čelusť je kalená a brúsená
- ▲ cena za kus

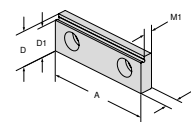

pre šírku zveráka	A	A ₁	D	D ₁	D ₂	E	M	M ₁	M ₂	EUR	Y4	NCG	H5G / -S / -Z	X5G-Z / -S	ESG 4	ESG 5	HDG 2	ZSG 4	ZSG mini	DSG 4	Verso	HSG	
65			22	19			8	5,5		72,40	80 895 332	●											

Stupňovitá čelusť, 5 mm s povlakom WC

- ▲ cena za kus

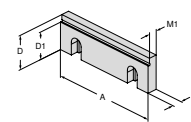

pre šírku zveráka	A	A ₁	D	D ₁	D ₂	E	M	M ₁	M ₂	EUR	Y4	NCG	H5G / -S / -Z	X5G-Z / -S	ESG 4	ESG 5	HDG 2	ZSG 4	ZSG mini	DSG 4	Verso	HSG	
80			28	23			10	7,5		156,00	80 878 31400				●			●		●			

Prehľad výmenných čeľustí všeobecne

Stupňovitá čeľusť, 5 mm s povlakom WC

▲ cena za kus

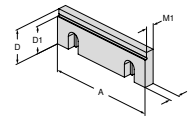

pre šírku zveráka	A	A ₁	D	D ₁	D ₂	E	M	M ₁	M ₂	EUR	Y4	NCG	H5G / -S / -Z	X5G-Z / -S	ESG 4	ESG 5	HDG 2	ZSG 4	ZSG mini	DSG 4	Verso	HSG	
100			35	30			10	7,5		171,00	80 892 36300	●					●						
125			40	35			11,5	9,5		151,00	80 892 250	●	●		●		●				●		●
160			50	45			13,5	10,5		213,00	80 892 36400	●			●		●		●				●

Stupňovitá čeľusť, 5 mm

▲ cena za kus

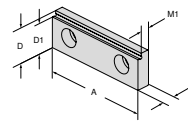

pre šírku zveráka	A	A ₁	D	D ₁	D ₂	E	M	M ₁	M ₂	EUR	Y4	NCG	H5G / -S / -Z	X5G-Z / -S	ESG 4	ESG 5	HDG 2	ZSG 4	ZSG mini	DSG 4	Verso	HSG	
80			28	23			10	7,5		128,00	80 878 830				●				●		●		

Stupňovitá čeľusť, grip

▲ cena za kus

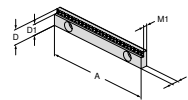

pre šírku zveráka	A	A ₁	D	D ₁	D ₂	E	M	M ₁	M ₂	EUR	Y4	NCG	H5G / -S / -Z	X5G-Z / -S	ESG 4	ESG 5	HDG 2	ZSG 4	ZSG mini	DSG 4	Verso	HSG	
125			18	13			8	5,5		135,00	80 898 252		●		●						●		
125			18	15			8	5,5		135,00	80 898 250		●		●						●		

Stupňovitá čeľusť, grip, 3 mm

▲ cena za kus

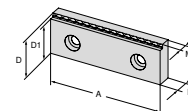

pre šírku zveráka	A	A ₁	D	D ₁	D ₂	E	M	M ₁	M ₂	EUR	Y4	NCG	H5G / -S / -Z	X5G-Z / -S	ESG 4	ESG 5	HDG 2	ZSG 4	ZSG mini	DSG 4	Verso	HSG	
80			28	25			10	7		91,70	80 906 30900				●				●		●		

Prehľad výmenných čeľustí všeobecne

Stupňovitá čeľusť, grip 3, 5 a 8 mm

▲ cena za kus

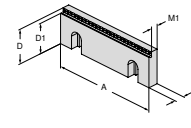

pre šírku zveráka	A	A ₁	D	D ₁	D ₂	E	M	M ₁	M ₂	EUR	Y4	NCG	H5G / -S / -Z	X5G-Z / -S	ESG 4	ESG 5	HDG 2	ZSG 4	ZSG mini	DSG 4	Verso	HSG		
100			35	27			10	7,5		108,00	80 892 29200	●					●						●	
100			35	30			10	7,5		108,00	80 892 29000	●					●							●
100			35	32			10	7,5		108,00	80 892 29400	●					●							●
125			40	32			11,5	9		124,00	80 892 29300	●	●		●		●	●			●			●
125			40	35			11,5	9		124,00	80 892 29100	●	●		●		●	●			●			●
125			40	37			11,5	9		124,00	80 892 29500	●	●		●		●	●			●			●
160			50	42			13,5	11		138,00	80 892 29900	●			●		●	●			●			●
160			50	45			13,5	11		138,00	80 892 29800	●			●		●	●			●			●
160			50	47			13,5	11		138,00	80 892 29700	●			●		●	●			●			●

Stupňovitá čeľusť, karbid grip 3 mm

▲ cena za kus

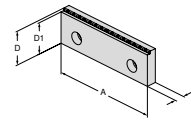

pre šírku zveráka	A	A ₁	D	D ₁	D ₂	E	M	M ₁	M ₂	EUR	Y4	NCG	H5G / -S / -Z	X5G-Z / -S	ESG 4	ESG 5	HDG 2	ZSG 4	ZSG mini	DSG 4	Verso	HSG		
100			35	32			7,5			156,00	80 892 37600	●	●		●		●	●		●				●
125			40	37			11,5			171,00	80 892 36500	●	●		●		●	●		●				●
160			50	47			13,5			195,00	80 892 37400	●	●		●		●	●		●				●

Stupňovitá čeľusť, karbid grip 5 mm

▲ cena za kus

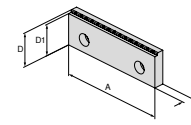

pre šírku zveráka	A	A ₁	D	D ₁	D ₂	E	M	M ₁	M ₂	EUR	Y4	NCG	H5G / -S / -Z	X5G-Z / -S	ESG 4	ESG 5	HDG 2	ZSG 4	ZSG mini	DSG 4	Verso	HSG		
100			35	30			12			156,00	80 892 37700	●	●		●		●	●		●				●
125			40	35			13,5			171,00	80 892 37500	●	●		●		●	●		●				●
160			50	45			15,5			195,00	80 892 37300	●	●		●		●	●		●				●

Stupňovitá čeľusť, 18 mm s 3 mm stupňom grip

▲ cena za kus

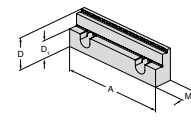

pre šírku zveráka	A	A ₁	D	D ₁	D ₂	E	M	M ₁	M ₂	EUR	Y4	NCG	H5G / -S / -Z	X5G-Z / -S	ESG 4	ESG 5	HDG 2	ZSG 4	ZSG mini	DSG 4	Verso	HSG		
125			40	22			21,5			222,00	80 892 288	●	●		●		●	●		●				●

Prehľad výmenných čeľustí všeobecne

Stupňovitá čeľusť, 18 mm s 3 mm stupňom grip

▲ cena za kus

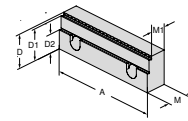

pre šírku zveráka	A	A ₁	D	D ₁	D ₂	E	M	M ₁	M ₂
	125		40	37	22		24	19	

EUR

Y4

235,00

80 907 302

NCG	H5G / -S / -Z	X5G-Z / -S	ESG 4	ESG 5	HDG 2	ZSG 4	ZSG mini	DSG 4	Verso	HSG
•	•		•		•	•		•		•

Stupňovitá čeľusť, grip 5 mm na hliník a plast

▲ cena za kus

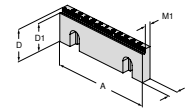

pre šírku zveráka	A	A ₁	D	D ₁	D ₂	E	M	M ₁	M ₂
	125		40	35			11,5	8	

EUR

Y4

143,00

80 892 36100

NCG	H5G / -S / -Z	X5G-Z / -S	ESG 4	ESG 5	HDG 2	ZSG 4	ZSG mini	DSG 4	Verso	HSG
•	•		•		•	•		•		•

Stupňovitá čeľusť, grip, so stupnicou

▲ zhodné s profilom LANG

▲ cena za kus

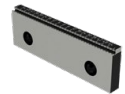
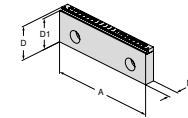

pre šírku zveráka	A	A ₁	D	D ₁	D ₂	E	M	M ₁	M ₂
	125		40	37			11,5		

EUR

Y4

138,00

80 892 36200

NCG	H5G / -S / -Z	X5G-Z / -S	ESG 4	ESG 5	HDG 2	ZSG 4	ZSG mini	DSG 4	Verso	HSG
•	•		•		•	•		•		•

Čeľusť, grip

▲ cena za kus

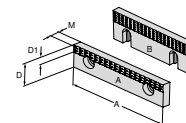

Názorné zobrazenie	A	A ₁	D	D ₁	D ₂	E	M	M ₁	M ₂
A	40		22	7			7,8		
A	65		22	7			7,8		
A	90		22	7			7,8		
B	100		35	12			10		
B	125		40	14,5			11,5		
B	160		50	14,5			13,5		

EUR

Y4

33,50

80 892 279

37,80

80 892 280

41,00

80 892 284

51,90

80 892 21700

60,50

80 892 21800

83,20

80 892 21900

NCG	H5G / -S / -Z	X5G-Z / -S	ESG 4	ESG 5	HDG 2	ZSG 4	ZSG mini	DSG 4	Verso	HSG
									•	
									•	
•					•					•
•			•		•			•		•
•			•		•	•				•

Prehľad výmenných čelustí všeobecne

Výmenná čelusť, grip

▲ cena za kus

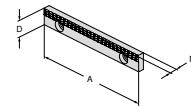

pre šírku zveráka	A	A ₁	D	D ₁	D ₂	E	M	M ₁	M ₂	EUR	Y4	NCG	H5G / -S / -Z	X5G-Z / -S	ESG 4	ESG 5	HDG 2	ZSG 4	ZSG mini	DSG 4	Verso	HSG	
	125		18				7,8			66,90	80 898 253	●	●	●							●		

Výmenná čelusť, brúsená

▲ cena za kus

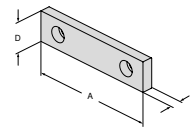

pre šírku zveráka	A	A ₁	D	D ₁	D ₂	E	M	M ₁	M ₂	EUR	Y4	NCG	H5G / -S / -Z	X5G-Z / -S	ESG 4	ESG 5	HDG 2	ZSG 4	ZSG mini	DSG 4	Verso	HSG		
	40		22				7,7			33,50	80 889 401											●		
	40		35				10			37,80	80 889 405												●	
	65		22				7,7			37,80	80 889 651												●	
	65		35				10			41,00	80 889 655												●	
	90		22				7,7			41,00	80 889 901												●	
	90		35				10			49,70	80 889 905												●	

Výmenná čelusť, brúsená

▲ cena za kus

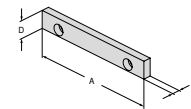

pre šírku zveráka	A	A ₁	D	D ₁	D ₂	E	M	M ₁	M ₂	EUR	Y4	NCG	H5G / -S / -Z	X5G-Z / -S	ESG 4	ESG 5	HDG 2	ZSG 4	ZSG mini	DSG 4	Verso	HSG	
	125		18				7,6			50,80	80 898 251	●	●	●							●		

Výmenná čelusť s povlakom WC

▲ s povlakom wolfrámkarbidu

▲ cena za kus

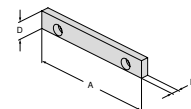

pre šírku zveráka	A	A ₁	D	D ₁	D ₂	E	M	M ₁	M ₂	EUR	Y4	NCG	H5G / -S / -Z	X5G-Z / -S	ESG 4	ESG 5	HDG 2	ZSG 4	ZSG mini	DSG 4	Verso	HSG	
	125		18				7,6			102,00	80 898 254	●	●	●							●		

Prehľad výmenných čelustí všeobecne

Čelusť, hladká

▲ cena za kus

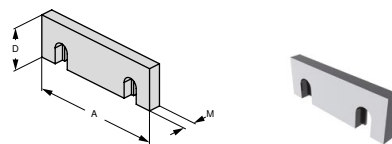

pre šírku zveráka	A	A ₁	D	D ₁	D ₂	E	M	M ₁	M ₂	EUR	Y4	NCG	H5G / -S / -Z	X5G-Z / -S	ESG 4	ESG 5	HDC 2	ZSG 4	ZSG mini	DSG 4	Verso	HSG		
100			35				10			40,00	80 892 20400	●					●						●	
125			40				11,5			48,60	80 892 20500	●			●		●				●			●
160			50				13,5			74,70	80 892 20600	●			●		●	●						●

Upínacia čelusť, profilovaná

▲ cena za kus

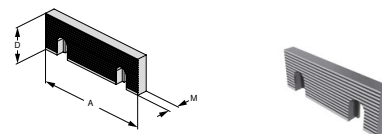

pre šírku zveráka	A	A ₁	D	D ₁	D ₂	E	M	M ₁	M ₂	EUR	Y4	NCG	H5G / -S / -Z	X5G-Z / -S	ESG 4	ESG 5	HDC 2	ZSG 4	ZSG mini	DSG 4	Verso	HSG		
100			35				10			45,40	80 892 20700	●											●	
125			40				11,5			55,10	80 892 20800	●			●		●	●			●			●
160			50				13,5			90,60	80 892 20900	●			●		●	●						●

Čelusť, grip, otočná

▲ pre vertikálne a horizontálne použitie

▲ cena za kus

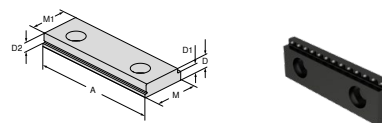

pre šírku zveráka	A	A ₁	D	D ₁	D ₂	E	M	M ₁	M ₂	EUR	Y4	NCG	H5G / -S / -Z	X5G-Z / -S	ESG 4	ESG 5	HDC 2	ZSG 4	ZSG mini	DSG 4	Verso	HSG	
65			8	5,5	5		22	19		36,80	80 895 340	●	●										
100			10,5	8	5		35	32		51,90	80 895 343	●	●				●						●

Čelusť, grip, otočná

▲ pre vertikálne a horizontálne použitie

▲ 3bodové upínanie

▲ cena za kus

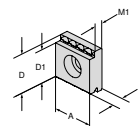

pre šírku zveráka	A	A ₁	D	D ₁	D ₂	E	M	M ₁	M ₂	EUR	Y4	NCG	H5G / -S / -Z	X5G-Z / -S	ESG 4	ESG 5	HDC 2	ZSG 4	ZSG mini	DSG 4	Verso	HSG	
65	22		22	19			8	5,5		19,50	80 895 335	●	●					●					
100	35		35	32			10,5	8		31,40	80 895 345	●	●				●						

Prehľad výmenných čelustí všeobecne

Čelusť, brúsená s vyrazením

▲ cena za kus

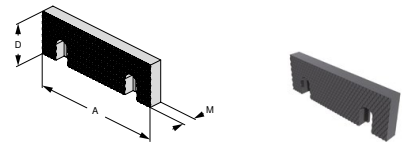

pre šírku zveráka	A	A ₁	D	D ₁	D ₂	E	M	M ₁	M ₂	EUR	Y4	NCG	H5G / -S / -Z	X5G-Z / -S	ESG 4	ESG 5	HDG 2	ZSG 4	ZSG mini	DSG 4	Verso	HSG		
	100		35				11			54,00	80 892 20100	●					●						●	
	125		40				12,5			65,90	80 892 20200	●			●		●				●			●
	160		50				14,5			76,60	80 892 20300	●			●		●	●						●

Čelusť, brúsená s vyrazením

▲ cena za kus

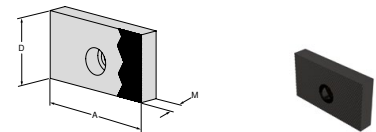

pre šírku zveráka	A	A ₁	D	D ₁	D ₂	E	M	M ₁	M ₂	EUR	Y4	NCG	H5G / -S / -Z	X5G-Z / -S	ESG 4	ESG 5	HDG 2	ZSG 4	ZSG mini	DSG 4	Verso	HSG		
	40		35				11			37,80	80 889 408												●	
	40		22				8			33,50	80 889 404													●
	65		35				11			41,00	80 889 658													●
	65		22				8			37,80	80 889 654													●
	90		35				11			49,70	80 889 908													●
	90		22				8			41,00	80 889 904													●

Mäkké čeluste, ocel'

- ▲ materiál: 16MnCr5
- ▲ iba pre vertikálne použitie
- ▲ cena za kus

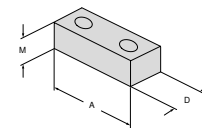

pre šírku zveráka	A	A ₁	D	D ₁	D ₂	E	M	M ₁	M ₂	EUR	Y4	NCG	H5G / -S / -Z	X5G-Z / -S	ESG 4	ESG 5	HDG 2	ZSG 4	ZSG mini	DSG 4	Verso	HSG		
	40		22				20			33,50	80 895 244												●	
	65		22				20			37,80	80 895 245		●		●				●					●
	90		22				20			41,00	80 895 246													●

Mäkké čeluste, ocel'

- ▲ materiál: 14NiCr14
- ▲ pre výrobu tvarových čelustí
- ▲ cena za kus

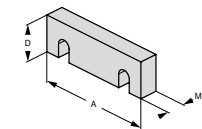

pre šírku zveráka	A	A ₁	D	D ₁	D ₂	E	M	M ₁	M ₂	EUR	Y4	NCG	H5G / -S / -Z	X5G-Z / -S	ESG 4	ESG 5	HDG 2	ZSG 4	ZSG mini	DSG 4	Verso	HSG		
	100		35				16			43,20	80 892 24700	●						●						●
	125		40				20			50,80	80 892 24800	●	●		●		●	●			●			●
	160		50				20			83,40	80 892 24900	●			●		●	●						●

Prehľad výmenných čelustí všeobecne

Prizmatická čelusť

- ▲ s vodorovnou a zvislou prizmou
- ▲ prizmy brúsené pre dodržanie kolmosti a rovnobežnosti
- ▲ cena za kus

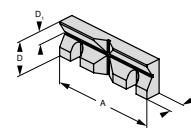

pre upínací priemer	A	A ₁	D	D ₁	D ₂	E	M	M ₁	M ₂	EUR	Y4	NCG	H5G / -S / -Z	X5G-Z / -S	ESG 4	ESG 5	HDG 2	ZSG 4	ZSG mini	DSG 4	Verso	HSG	
11 - 41	100		35	13			15,5			128,40	80 892 26100	●					●						●
14 - 48	125		40	16			17,5			142,90	80 892 26200	●	●		●		●				●		●
16 - 60	160		50	20			19,5			214,00	80 892 26300	●			●		●	●					●

Prizmatická čelusť

- ▲ s vodorovnou a zvislou prizmou
- ▲ cena za kus

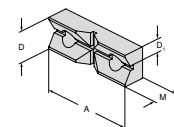

pre upínací priemer	A	A ₁	D	D ₁	D ₂	E	M	M ₁	M ₂	EUR	Y4	NCG	H5G / -S / -Z	X5G-Z / -S	ESG 4	ESG 5	HDG 2	ZSG 4	ZSG mini	DSG 4	Verso	HSG	
11 - 22	65		22	11			15			131,00	80 895 337		●					●					

Presná sťahovacia čelusť

- ▲ sťahovacia čelusť je určená iba pre použitie na pohyblivé čeluste
- ▲ cena za kus

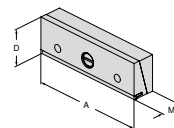

pre šírku zveráka	A	A ₁	D	D ₁	D ₂	E	M	M ₁	M ₂	EUR	Y4	NCG	H5G / -S / -Z	X5G-Z / -S	ESG 4	ESG 5	HDG 2	ZSG 4	ZSG mini	DSG 4	Verso	HSG	
100			35				25			259,00	80 892 370	●											●
125			40				25			268,00	80 892 371	●	●		●		●				●		●
160			50				27,5			409,00	80 892 372	●			●		●	●					●

Medzičelusť s pružnicou

- ▲ pre typy NCG, NCG 2 a HDG 2
- ▲ s obojstrannými pružnicami spodného pritiahnutia
- ▲ cena za kus

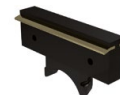
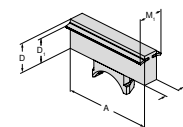

pre šírku zveráka	A	A ₁	D	D ₁	D ₂	E	M	M ₁	M ₂	EUR	Y4	NCG	H5G / -S / -Z	X5G-Z / -S	ESG 4	ESG 5	HDG 2	ZSG 4	ZSG mini	DSG 4	Verso	HSG	
100			35	28			28	45		289,00	80 892 258	●											
125			40	32,5			20	35		283,00	80 892 259	●					●						
160			50	42			20	35		337,00	80 892 260	●					●						

Prehľad výmenných čelustí všeobecne

Výmenná čelusť Multipin

▲ cena za kus

NCG HDG
2



80 890 ...

EUR
Y4
315,00 30200

A mm	D mm
125	40

Sťahovacia čelusť s pružnicou

▲ pre obrábanie hotových dielov
▲ cena za kus

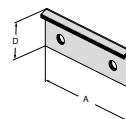

pre šírku zveráka	A	A ₁	D	D ₁	D ₂	E	M	M ₁	M ₂	EUR	Y4	NCG	H5G / -S / -Z	X5G-Z / -S	ESG 4	ESG 5	HDG 2	ZSG 4	ZSG mini	DSG 4	Verso	HSG	
	80		24							66,90	80 901 309												
	125		35							87,40	80 901 310				●				●		●		
	160		45							99,30	80 901 311				●				●		●		

Sťahovacia čelusť s pružnicou

▲ pre obrábanie hotových dielov
▲ cena za kus

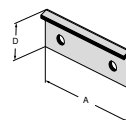

pre šírku zveráka	A	A ₁	D	D ₁	D ₂	E	M	M ₁	M ₂	EUR	Y4	NCG	H5G / -S / -Z	X5G-Z / -S	ESG 4	ESG 5	HDG 2	ZSG 4	ZSG mini	DSG 4	Verso	HSG	
	65		23							57,30	80 898 923												
	100		36							73,40	80 898 924								●				●
	125		41							87,40	80 898 925								●				●
	160		51							99,30	80 898 926								●				●

Pružnicová sťahovacia čelusť

▲ cena za kus

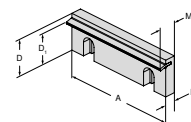

pre šírku zveráka	A	A ₁	D	D ₁	D ₂	E	M	M ₁	M ₂	EUR	Y4	NCG	H5G / -S / -Z	X5G-Z / -S	ESG 4	ESG 5	HDG 2	ZSG 4	ZSG mini	DSG 4	Verso	HSG	
	100		35	28			10	18,5		59,50	80 892 22800	●					●						●
	125		40	32,5			11,5	19		69,10	80 892 22900	●			●		●				●		●
	160		50	42			13,5	21		89,60	80 892 23000	●			●		●				●		●

Prehľad podložiek pod obrobok

Podložka pod obrobok, odsadená

- ▲ kalená a brúsená
- ▲ v základnej doske ju pridržiuje zvieracie pružina
- ▲ cena za 2 kusy

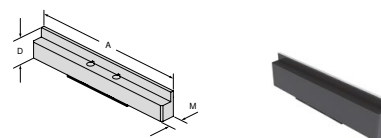

pre šírku zveráka	A	A ₁	D	D ₁	D ₂	E	M	M ₁	M ₂	EUR	Y4	NCG	H5G / -S / -Z	X5G-Z / -S	ESG 4	ESG 5	HDG 2	ZSG 4	ZSG mini	DSG 4	Verso	HSG		
100			16				10,5			135,00	80 890 401	●												
100			11				10,5			135,00	80 890 400	●												
100			23				10,5			135,00	80 890 409	●												
100			25,5				10,5			135,00	80 890 411	●												
100			29,5				10,5			135,00	80 890 421	●												
125			32,5				10,5			157,00	80 890 395	●												
125			11				10,5			157,00	80 890 390	●												
125			16				10,5			157,00	80 890 391	●												
125			21				10,5			157,00	80 890 392	●												
125			26				10,5			157,00	80 890 393	●												
125			29				10,5			157,00	80 890 394	●												
125			36				10,5			157,00	80 890 396	●												
125			25				10,5			157,00	80 890 422	●												
160			39				10,5			200,00	80 890 454	●												
160			26				10,5			190,00	80 890 452	●												
160			42,5				10,5			214,00	80 890 456	●												

pre šírku zveráka	A	A ₁	D	D ₁	D ₂	E	M	M ₁	M ₂	EUR	Y4	NCG	H5G / -S / -Z	X5G-Z / -S	ESG 4	ESG 5	HDG 2	ZSG 4	ZSG mini	DSG 4	Verso	HSG	
125							10,5			1.030,00	80 890 399	●											

 **80 890 399:** súprava so 7 podložkami pod obrobok po 2 ks v drevenej krabici (okrem 80 890 422)

Podložka pod obrobok, odsadená

- ▲ kalená a brúsená
- ▲ v základnej doske ju pridržiuje zvieracie pružina
- ▲ cena za sadu

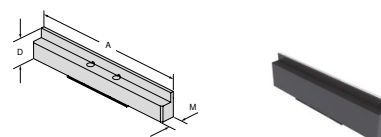

pre šírku zveráka	A	A ₁	D	D ₁	D ₂	E	M	M ₁	M ₂	EUR	Y4	NCG	H5G / -S / -Z	X5G-Z / -S	ESG 4	ESG 5	HDG 2	ZSG 4	ZSG mini	DSG 4	Verso	HSG			
125			11				10,5			153,00	80 901 703				●										
125			21				10,5			157,00	80 901 704				●										
125			25				10,5			153,00	80 901 705				●										
160			26				10,5			186,00	80 901 700				●										
125			32,5				10,5			153,00	80 901 706				●										
160			39				10,5			196,00	80 901 701				●										
160			42,5				10,5			210,00	80 901 702				●										

Podložka pod obrobok, odsadená

- ▲ kalená a brúsená
- ▲ v základnej doske ju pridržiuje zvieracie pružina
- ▲ cena za sadu

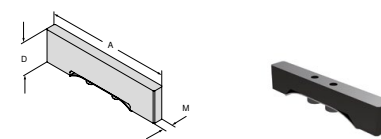

pre šírku zveráka	A	A ₁	D	D ₁	D ₂	E	M	M ₁	M ₂	EUR	Y4	NCG	H5G / -S / -Z	X5G-Z / -S	ESG 4	ESG 5	HDG 2	ZSG 4	ZSG mini	DSG 4	Verso	HSG				
80			15				10,5			127,00	80 901 707				●											
80			20				10,5			127,00	80 901 708				●											

Prehľad podložiek pod obrobok

Podložka pod obrobok, odsadená

- ▲ kalená a brúsená
- ▲ v základnej doske ju pridržiuje zvieracia pružina
- ▲ cena za sadu

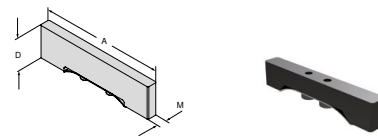

pre šírku zveráka	A	A ₁	D	D ₁	D ₂	E	M	M ₁	M ₂	EUR	Y4	NCG	H5G / -S / -Z	X5G-Z / -S	ESG 4	ESG 5	HDG 2	ZSG 4	ZSG mini	DSG 4	Verso	HSG			
125			15				10,5			157,00	80 906 715														
125			22				10,5			157,00	80 906 722														
125			25				10,5			157,00	80 906 725														
125			32,5				10,5			157,00	80 906 732														

Podložky pod obrobok

- ▲ kalené a brúsené
- ▲ v základnej doske ju pridržiuje zvieracia pružina
- ▲ cena za 2 kusy

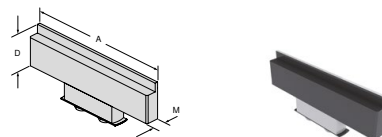

pre šírku zveráka	A	A ₁	D	D ₁	D ₂	E	M	M ₁	M ₂	EUR	Y4	NCG	H5G / -S / -Z	X5G-Z / -S	ESG 4	ESG 5	HDG 2	ZSG 4	ZSG mini	DSG 4	Verso	HSG			
100			16				10,5			131,00	80 892 401														
100			25,5				10,5			131,00	80 892 411														
100			29,5				10,5			131,00	80 892 421														
125			11				10,5			157,00	80 892 390														
125			16				10,5			157,00	80 892 391														
125			21				10,5			157,00	80 892 392														
125			26				10,5			157,00	80 892 393														
125			29				10,5			157,00	80 892 394														
125			32,5				10,5			157,00	80 892 395														
125			36				10,5			157,00	80 892 396														
160			26				10,5			190,00	80 892 403														
160			39				10,5			200,00	80 892 413														
160			42,5				10,5			214,00	80 892 423														

pre šírku zveráka	A	A ₁	D	D ₁	D ₂	E	M	M ₁	M ₂	EUR	Y4	NCG	H5G / -S / -Z	X5G-Z / -S	ESG 4	ESG 5	HDG 2	ZSG 4	ZSG mini	DSG 4	Verso	HSG			
125							10,5			1.030,00	80 892 399														

 80 890 399: súprava so 7 súpravami à 2 ks v drevenej krabici

Magnetická podložka pod obrábok, sada



- ▲ s odľahčením na spodnej strane
- ▲ flexibilné a účelné upínanie
- ▲ výšková presnosť +/- 0,01 mm
- ▲ jednoduchá a rýchla montáž vďaka upnutiu magnetom

Prehľad podložiek pod obrábok

Magnetická podložka pod obrábok, sada

- ▲ nehrdzavejúca pružinová oceľ
- ▲ zalisované magnety
- ▲ dodanie v sade: 5 párov
- ▲ cena za sadu



A	D	M	EUR	Y4	NCG	H5G /-S /-Z	X5G-Z /-S	ESG 4	ESG 5	HDG 2	ZSG 4	ZSG mini	DSG 4	Verso	HSG
80	5 / 10 / 15 / 20 / 22	2,5	297,00	80 878 79800	●		●	●			●		●		
125	8 / 12 / 15 / 20 / 22	2,5	334,00	80 878 79700	●		●	●			●		●		
125	8 / 12 / 20 / 25 / 27	2,5	334,00	80 878 79900	●		●	●			●		●		

Magnetická podložka pod obrábok, sada

- ▲ nehrdzavejúca pružinová oceľ
- ▲ zalisované magnety
- ▲ dodanie v sade: 5 párov
- ▲ cena za sadu



A	D	M	EUR	Y4	NCG	H5G /-S /-Z	X5G-Z /-S	ESG 4	ESG 5	HDG 2	ZSG 4	ZSG mini	DSG 4	Verso	HSG
100	12 / 20 / 25 / 30 / 32	2,5	325,00	80 892 79700	●		●				●				
125	12 / 25 / 30 / 35 / 37	2,5	342,00	80 892 79800	●		●				●		●		
160	15 / 30 / 40 / 45 / 47	2,5	360,00	80 892 79900	●		●	●			●		●		

Magnetická podložka pod obrábok, sada

- ▲ nehrdzavejúca pružinová oceľ
- ▲ zalisované magnety
- ▲ dodanie v sade: 5 párov
- ▲ cena za sadu



A	D	M	EUR	Y4	NCG	H5G /-S /-Z	X5G-Z /-S	ESG 4	ESG 5	HDG 2	ZSG 4	ZSG mini	DSG 4	Verso	HSG
125	9 / 22 / 27 / 32 / 34	2,5	334,00	80 901 79900	●		●				●		●		

Prehľad podložiek pod obrábok

Magnetické podložky pod obrábok

▲ cena za pár

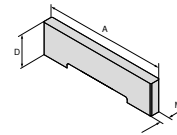

A	D	M	EUR	Y4	NCG	H5G / -S / -Z	X5G-Z / -S	ESG 4	ESG 5	H5G 2	Z5G 4	Z5G mini	DSG 4	Verflo	H5G
80	5	2,5	68,00	80 892 79600											
80	10	2,5	68,00	80 892 79500											
80	15	2,5	68,00	80 892 79400											
80	20	2,5	68,00	80 892 79300											
80	22	2,5	68,00	80 892 79200											
100	12	2,5	71,30	80 892 79100											
100	20	2,5	71,30	80 892 79000											
100	25	2,5	71,30	80 892 78900											
100	27	2,5	71,30	80 892 78800											
100	29	2,5	71,30	80 892 78700											
100	30	2,5	71,30	80 892 78600											
100	31	2,5	71,30	80 892 78500											
100	32	2,5	71,30	80 892 78400											
125	8	2,5	74,50	80 892 78300											
125	9	2,5	74,50	80 892 78200											
125	10	2,5	74,50	80 892 78100											
125	12	2,5	74,50	80 892 78000											
125	15	2,5	74,50	80 892 77900											
125	20	2,5	74,50	80 892 77800											
125	22	2,5	74,50	80 892 77700											
125	23	2,5	74,50	80 892 77600											
125	25	2,5	74,50	80 892 77500											
125	27	2,5	74,50	80 892 77400											
125	30	2,5	74,50	80 892 77300											
125	31	2,5	74,50	80 892 77200											
125	32	2,5	74,50	80 892 77100											
125	33	2,5	74,50	80 892 77000											
125	34	2,5	74,50	80 892 76900											
125	35	2,5	74,50	80 892 76800											
125	36	2,5	74,50	80 892 76700											
125	37	2,5	74,50	80 892 76600											
160	15	2,5	81,00	80 892 76500											
160	22	2,5	81,00	80 892 76400											
160	30	2,5	81,00	80 892 76300											
160	37	2,5	81,00	80 892 76200											
160	40	2,5	81,00	80 892 76100											
160	41	2,5	81,00	80 892 76000											
160	42	2,5	81,00	80 892 75900											
160	43	2,5	81,00	80 892 75800											
160	44	2,5	81,00	80 892 75700											
160	45	2,5	82,00	80 892 75600											
160	46	2,5	81,00	80 892 75500											
160	47	2,5	81,00	80 892 75400											

Doraz obrábku, magnetický

Rozsah dodávky:

Vrátane dorazovej tyčky 50 mm / 100 mm



Pre šírku mm	Veľkosť	80 892 ...
		EUR Y4
80/100/125/160	60x15	113,00 23800
80/100/125/160	115x15	164,00 23900

Predĺženie pre doraz obrábku, magnetické

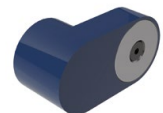

Pre šírku mm	Veľkosť	80 892 ...
		EUR Y4
80/100/125/160	68x30 mm	87,40 25400

Prehľad všeobecného príslušenstva

Súprava pre vyrovnávanie
a stredenie do T-drážok

▲ cena za kus

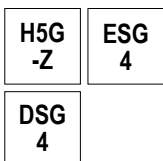

80 897 ...

I mm	Pre šírku drážky mm	EUR Y4	
100	14	57,10	114
100	16	57,10	116
100	18	57,10	118

Súprava na vyrovnávanie
a stredenie do T-drážok

▲ cena za kus

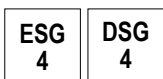

80 906 ...

I mm	Pre šírku drážky mm	EUR Y4	
80	12	59,50	812
80	14	59,50	814
80	16	59,50	816
80	18	59,50	818

Súprava upínacích skrutiek
k T-drážke pre MNG

▲ cena za 2 kusy



80 899 ...

Pre šírku mm	G	EUR Y4	
12	M10	15,20	312
14	M12	15,20	314
16	M12	20,50	316
18	M12	26,00	318

Doraz obrobku

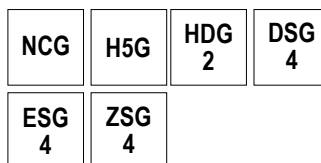

80 892 ...

EUR
Y4
81,70 400

Doraz obrobku

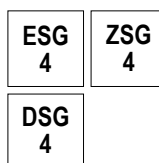

80 895 ...

EUR
Y4
44,80 010

Doraz obrobku

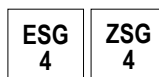

80 884 ...

EUR
Y4
43,70 400

Prehľad všeobecného príslušenstva

Náhradná pružnica

- ▲ pre sťahovacie čeluste a medzičeluste
- ▲ cena za kus

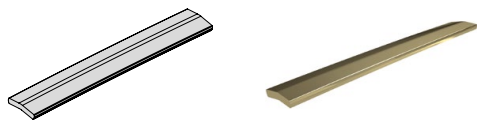

Pre šírku mm	80 892 ... EUR Y4	
100	23,90	430
125	24,90	431
160	27,10	432

Upínacie pätky

- ▲ cena za 2 kusy

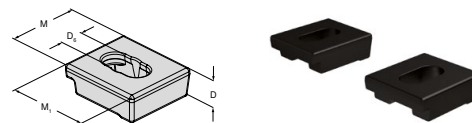

D mm	D ₆ mm	M mm	M ₁ mm	80 890 ... EUR Y4	
20	16	50	57	38,10	315

Prehľad upínacích pák

Upínacia páka s kĺbom

▲ bez orecha

Krútiaci moment v Nm	Štvorhran	DRVS	EUR	Y4	NCG	H5G / -S / -Z	X5G-Z / -S	ESG 4	ESG 5	HDG 2	ZSG 4	ZSG mini	DSG 4	Verso	HSG	MING	MING mini
	1/2"		76,10	80 891 600				●			●						



Momentový kľúč

▲ bez orecha

Krútiaci moment v Nm	Štvorhran	DRVS	EUR	Y4	NCG	H5G / -S / -Z	X5G-Z / -S	ESG 4	ESG 5	HDG 2	ZSG 4	ZSG mini	DSG 4	Verso	HSG	MING	MING mini
10 - 100	1/2"		280,00	80 884 502				●			●	●	●				
20 - 200	1/2"		280,00	80 884 504				●			●	●	●				



Momentový kľúč

▲ bez orecha

Krútiaci moment v Nm	Štvorhran	DRVS	EUR	Y4	NCG	H5G / -S / -Z	X5G-Z / -S	ESG 4	ESG 5	HDG 2	ZSG 4	ZSG mini	DSG 4	Verso	HSG	MING	MING mini
5 - 50	3/8"		280,00	80 884 402								●		●		●	



Súprava náradia

▲ momentový kľúč vr. orecha, skrutkovač SW10 a 1/2" predĺženie

Krútiaci moment v Nm	Štvorhran	DRVS	EUR	Y4	NCG	H5G / -S / -Z	X5G-Z / -S	ESG 4	ESG 5	HDG 2	ZSG 4	ZSG mini	DSG 4	Verso	HSG	MING	MING mini
8 - 50	3/8"	10	329,00	80 899 410												●	



Prehľad upínacích pák

Orech

▲ vhodný pre štvorhran 1/2" alebo 3/8"



Krútiaci moment v Nm	Štvorhran	DRVS	EUR	Y4	NCG	H5G / -S / -Z	X5G-Z / -S	ESG 4	ESG 5	HDC 2	ZSG 4	ZSG mini	DSG 4	Veriso	HSG	MNG	MNG mini
	3/8"	5	18,20	80 877 105													
	3/8"	6	18,20	80 877 10600													
	3/8"	8	18,20	80 877 108										•		•	•
	1/2"	8	18,20	80 877 208													
	1/2"	10	18,20	80 877 210													
	1/2"	14	18,20	80 877 214			•										

Orech

▲ vhodný pre štvorhran 1/2" alebo 3/8"



Krútiaci moment v Nm	Štvorhran	DRVS	EUR	Y4	NCG	H5G / -S / -Z	X5G-Z / -S	ESG 4	ESG 5	HDC 2	ZSG 4	ZSG mini	DSG 4	Veriso	HSG	MNG	MNG mini
	3/8"	7	18,20	80 875 107													
	3/8"	11	18,20	80 875 11100								•					
	3/8"	12	18,20	80 875 112				•			•		•				
	1/2"	12	18,20	80 875 212				•			•		•				
	1/2"	14	18,20	80 875 214				•			•		•				

Prehľad skrutiek

Upínacia skrutka pre otočné čeľuste

- ▲ DIN EN ISO 4762 (1998-02)
- ▲ cena za kus



pre šírku zveráka	G	J ₁₇	EUR	Y4	NCG	H5G / -S / -Z	X5G-Z / -S	ESG 4	ESG 5	HDG 2	ZSG 4	ZSG mini	DSG 4	Verso	HSG	MNG	MNG mini
	M8x12		1,20	80 892 296	•	•				•	•						
	M6x8		1,20	80 895 013								•		•			

Upínacia skrutka s nízkou hlavou pre výmenné čeľuste

- ▲ podľa DIN7984 (1985-05)
- ▲ cena za kus



pre šírku zveráka	G	J ₁₇	EUR	Y4	NCG	H5G / -S / -Z	X5G-Z / -S	ESG 4	ESG 5	HDG 2	ZSG 4	ZSG mini	DSG 4	Verso	HSG	MNG	MNG mini
	M8x10		1,20	80 889 950	•	•				•	•						

Upínacia skrutka pre systémové výmenné čeľuste

- ▲ cena za kus



pre šírku zveráka	G	J ₁₇	EUR	Y4	NCG	H5G / -S / -Z	X5G-Z / -S	ESG 4	ESG 5	HDG 2	ZSG 4	ZSG mini	DSG 4	Verso	HSG	MNG	MNG mini
	M12x20		1,20	80 890 630	•	•											
	M12x40		2,30	80 890 632	•	•											

Valcová skrutka s vnútorným šesťhranom

- ▲ DIN 912
- ▲ cena za kus



pre šírku zveráka	G	J ₁₇	EUR	Y4	NCG	H5G / -S / -Z	X5G-Z / -S	ESG 4	ESG 5	HDG 2	ZSG 4	ZSG mini	DSG 4	Verso	HSG	MNG	MNG mini
	M12x45		2,30	80 899 124												•	

Lícovaná skrutka

- ▲ cena za 2 kusy



pre šírku zveráka	G	J ₁₇	EUR	Y4	NCG	H5G / -S / -Z	X5G-Z / -S	ESG 4	ESG 5	HDG 2	ZSG 4	ZSG mini	DSG 4	Verso	HSG	MNG	MNG mini
100	M12x38	12	45,70	80 890 313	•			•									
125 / 160	M16x55	16	60,80	80 890 314	•												

Prehľad skrutiek

Lícovaná skrutka

▲ cena za 2 kusy



pre šírku zveráka	G	J ₁₇	EUR	Y4	NCG	H5G / -S / -Z	X5G-Z / -S	ESG 4	ESG 5	HDG 2	ZSG 4	ZSG mini	DSG 4	Verso	HSG	MING	MING mini
125	M12x45	12	26,20	80 895 019	●	●	●	●	●	●	●	●	●	●	●	●	●

Upínacia skrutka do T-drážky

▲ vr. kameňa do T-drážky a podložky

▲ cena za 2 kusy



pre šírku drážky	G	J ₁₇	EUR	Y4	NCG	H5G / -S / -Z	X5G-Z / -S	ESG 4	ESG 5	HDG 2	ZSG 4	ZSG mini	DSG 4	Verso	HSG	MING	MING mini
12	M10		24,30	80 890 308	●	●	●	●	●	●	●	●	●	●	●	●	●
14	M12		24,30	80 890 309	●	●	●	●	●	●	●	●	●	●	●	●	●
16	M14		25,20	80 890 310	●	●	●	●	●	●	●	●	●	●	●	●	●
18	M16		26,30	80 890 311	●	●	●	●	●	●	●	●	●	●	●	●	●

Upínacia skrutka na guľaté pätky do T-drážky

▲ vr. kameňa do T-drážky a podložky

▲ cena za 2 kusy



pre šírku drážky	G	J ₁₇	EUR	Y4	NCG	H5G / -S / -Z	X5G-Z / -S	ESG 4	ESG 5	HDG 2	ZSG 4	ZSG mini	DSG 4	Verso	HSG	MING	MING mini
12	M10		15,80	80 899 112										●	●	●	●
14	M12		15,80	80 899 114										●	●	●	●
16	M12		17,30	80 899 116										●	●	●	●
18	M12		18,50	80 899 118										●	●	●	●

Lícovaný kameň do drážky vr. skrutky

▲ cena za 2 kusy



pre šírku drážky	G	J ₁₇	EUR	Y4	NCG	H5G / -S / -Z	X5G-Z / -S	ESG 4	ESG 5	HDG 2	ZSG 4	ZSG mini	DSG 4	Verso	HSG	MING	MING mini
12	M6		91,20	80 898 412	●	●	●	●	●	●	●	●	●	●	●	●	●
14	M6		91,20	80 898 414	●	●	●	●	●	●	●	●	●	●	●	●	●
16	M6		91,20	80 898 416	●	●	●	●	●	●	●	●	●	●	●	●	●
18	M6		91,20	80 898 418	●	●	●	●	●	●	●	●	●	●	●	●	●