



 ZSG 1

 CERATIZIT GROUP MNG mini

 ZSG mini

## Nieuwe producten voor spannen

### **NEW** Mechanisch nulpuntsysteem – MNG mini



149-151

**MNG  
mini**

Gewichtsgeoptimaliseerde consoles, piramides en spantorens met geïntegreerd nulpuntsysteem voor kleine spanners.

### **NEW** CentriClamp – ZSG mini



92-100

**ZSG  
mini**

De ZSG mini is ideaal voor het spannen van zeer kleine onderdelen!

### **NEW** PolyClamp – Verso



111-124

**Verso**

De nieuwe, flexibel inzetbare meervoudige spanner met snelwisselsysteem voor het spannen van vele kleine maar ook grotere werkstukken!

Boren en nabewerken

1 HSS boren

2 VHM boren

3 Wisselplaat boren

4 Ruimen en verzinken

5 Kotten

Draadsnijbewerkingen

6 Tappen

7 Circulair- en schroefdraadfrezen

8 Draadsnijden

Draaibewerkingen

9 Draaien

10 EcoCut en FreeTurn

11 Steken

12 Miniatuur draaien en SlotCut

Freesbewerkingen

13 HSS frezen

14 VHM frezen

15 Wisselplaat frezen

Spanteknik

16 Opnames en toebehoren

17 Werkstuk spannen

18 Materiaalvoorbeelden en artikelnr.-index

## Inhoudsopgave

PolyClamp – Verso	4
Overzicht spansystemen	5
Toolfinder – Spansystemen	6–9
Programma	10–183
Overzicht algemene bekken	164–173
Overzicht werkstuk onderlegplaten	174–177
Overzicht algemene toebehoren	178+179
Overzicht spanhendels	180+181
Overzicht bouten	182+183

## WNT \ Performance

Premium-kwaliteitsgereedschappen voor de hoogste prestatie.

De premium-kwaliteitsgereedschappen uit de **WNT Performance** productlijn zijn voor speciale toepassingen ontworpen en kenmerken zich door hun buitengewone prestatie. Indien u in uw productie de hoogste eisen aan efficiëntie stelt en de allerbeste resultaten wilt bereiken, dan bevelen wij u de premium gereedschappen uit deze productlijn aan.

## PolyClamp – Verso

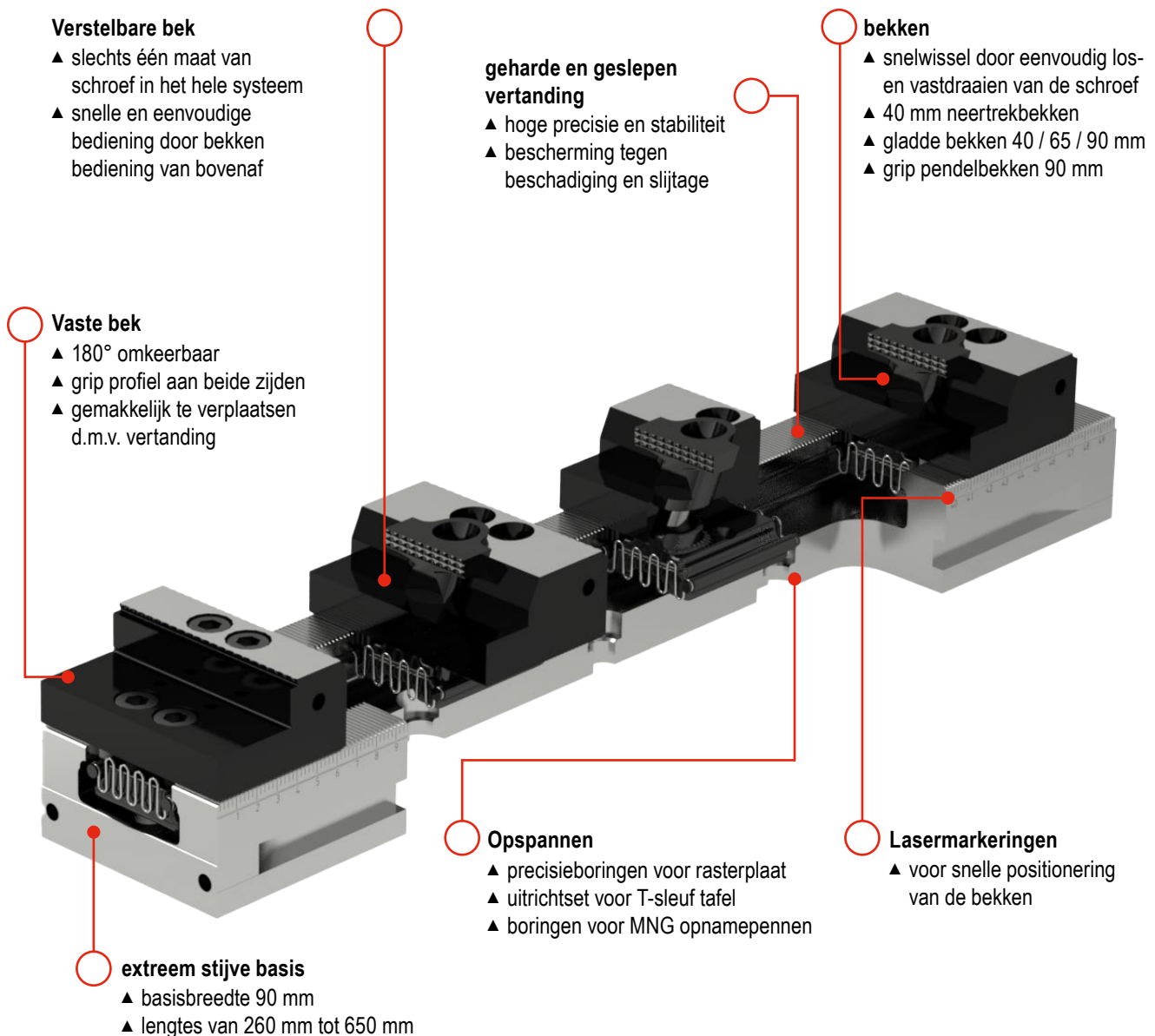

## Overzicht spansystemen

### SoloClamp – Enkelspanner

- ▲ krachtversterkte systemen NCG, HDG 2 en H5G
- ▲ vast bek als referentie
- ▲ hoge repeeternauwkeurigheid
- ▲ zeer goede hoeknauwkeurigheid



» Grote precisie en krachtversterking

### CentriClamp – Centrischspanner

- ▲ symmetrische spannen
- ▲ zeer goede toegankelijkheid voor 5-zijdige bewerking
- ▲ werkstuk nulpunt altijd in het midden (gecentreerd)
- ▲ hoge repeeternauwkeurigheid



» Hoge proceszekerheid door ingekapselde systemen

### PolyClamp – Meervoudige spanner

- ▲ verkorting van de ombouwtijden
- ▲ multifunctioneel inzetbaar
- ▲ optimale benutting van de machinetafel
- ▲ hoge repeeternauwkeurigheid



» verhoging van de machine looptijden

### Stationaire 3-klauwplaat – SBF 3

- ▲ bijzonder geschikt voor gebruik op een (3/5-assige) freesmachine met ronde werkstukken
- ▲ passend op PNG- en MNG-nulpuntspansystemen
- ▲ Spiestang-systeem
- ▲ Geharde en extreem stijve klauwplaat
- ▲ Geoptimaliseerd smeersysteem



» De ideale opspanning voor ronde werkstukken

### Opspanvarianten

- ▲ Nulpuntspansysteem
- ▲ Nulpuntspansysteem rasterplaten
- ▲ MNG – Mechanische nulpuntspansysteem
- ▲ PNG – pneumatisch nulpuntspansysteem



» Reducering van de ombouwtijden

### Opspanoren

- ▲ rechthoekige toren
- ▲ driehoekige toren
- ▲ kruistoren
- ▲ vierkante toren



» Automatisering eenvoudig gemaakt







Verschillende opspanoren vindt u in onze online shop op [cuttingtools.ceratizit.com](http://cuttingtools.ceratizit.com)



# Toolfinder spansystemen

type	omschrijving	3-As	4-As	5-As
SoloClamp – Enkelspanner	<b>NCG</b>  <ul style="list-style-type: none"> <li>▲ 160° snelspanning</li> <li>▲ snelle in- en uitbouw van de spindel</li> <li>▲ klemming op trek</li> </ul>	✓	✓	
	<b>NCG 5A</b>  <ul style="list-style-type: none"> <li>▲ 160° snelspanning</li> <li>▲ voor 5-as bewerking</li> <li>▲ klemming op trek</li> </ul>	✓		✓
	<b>H5G</b>  <ul style="list-style-type: none"> <li>▲ hendel snelspanning</li> <li>▲ 5-as krachtspanner</li> <li>▲ 100% ingekapseld</li> </ul>	✓		✓
	<b>H5G -Z</b>  <ul style="list-style-type: none"> <li>▲ hendel-snelspanning</li> <li>▲ 5-as krachtspanner</li> <li>▲ 100 % ingekapseld</li> <li>▲ met verplaatsbare vaste bek</li> </ul>	✓		✓
	<b>X5G -Z</b>  <ul style="list-style-type: none"> <li>▲ 100 % ingekapseld</li> <li>▲ zeer toegankelijk</li> <li>▲ 5- en 6-zijdenbewerking mogelijk</li> <li>▲ Bekken snel verwisselbaar zonder gereedschap</li> </ul>	✓		✓
	<b>ESG 4</b>  <ul style="list-style-type: none"> <li>▲ 100 % ingekapseld</li> <li>▲ nauwkeurige basis</li> <li>▲ hoge spankracht</li> <li>▲ groter spanbereik</li> </ul>	✓	✓	✓
	<b>ESG 5</b>  <ul style="list-style-type: none"> <li>▲ nieuwe uitvoering van de ingekapselde centriscspanner ZSG 4 als enkelspanner</li> <li>▲ identieke afmetingen en functies als de ZSG 4</li> </ul>	✓	✓	✓
	<b>HDG 2</b>  <ul style="list-style-type: none"> <li>▲ mechanische krachtoverbrenging</li> <li>▲ spankracht met slechts één omwenteling</li> <li>▲ traploze spankrachtinstelling</li> </ul>	✓		
CentriClamp – Centriscspanner	<b>ZSG 4</b>  <ul style="list-style-type: none"> <li>▲ kogelgelagerde, spelingsvrije spindel</li> <li>▲ grote precisie, spankracht en proceszekerheid</li> <li>▲ repeteernauwkeurigheid ± 0,01 mm</li> </ul>	✓	✓	✓
	<b>ZSG mini</b>  <ul style="list-style-type: none"> <li>▲ bekken snel verwisselbaar zonder gereedschap</li> <li>▲ compact en nauwkeurig</li> <li>▲ beste toegankelijkheid van alle zijden</li> <li>▲ RVS en geharde basis</li> </ul>	✓	✓	✓

	bekbreedte in mm	lengte van basis in mm	max. spanbereik in mm	rechthoekige werkstukken	onregelmatige werkstukken	ronde werkstukken	max. spankracht in kN	pagina
	100 125 160	305 390 530	245 343 506	✓	✓	✓	30 40 40	10-21
	100 125	305 390	199 269	✓		✓	18 24	13-21
	125	300	249	✓	✓	✓	40	22-36
	125	330 430 500 630	396 466 578	✓	✓	✓	40	26-36
	125	330 430 500 630 800	80-210 80-310 80-380 80-510 80-688	✓	✓	✓	40	37
	80 125 160	214 362 480	192 308 434	✓	✓	✓	25 40 50	49-58
	80 125 160	130+190 160+235+300 280+480	63-171 84-281 125-448	✓	✓	✓	35 35 50	59-66
	100 125 160	342 400 544	278 338 470	✓		✓	30 40 60	68-71
	80 125 160	130+190 160+235+300 280+480	121-185 163-303 134-462	✓	✓	✓	25 40 50	72-90
	45 70	80 100	7-77	✓	✓	✓	16	92-100

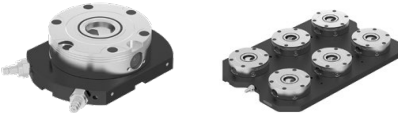
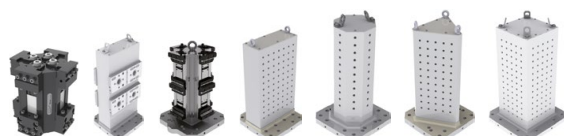

## Toolfinder spansystemen

type	omschrijving	3-As	4-As	5-As
PolyClamp – Meervoudige spanner	<b>DSG 4</b>  <ul style="list-style-type: none"> <li>▲ snelle demontage en montage</li> <li>▲ flexibel spansysteem</li> <li>▲ om te bouwen naar enkelspanner</li> </ul>	✓	✓	✓
	<b>Verso</b>  <ul style="list-style-type: none"> <li>▲ modulair spansysteem</li> <li>▲ spant meerdere kleine of grotere componenten op</li> <li>▲ innovatief meervoudig spansysteem</li> </ul>	✓	✓	✓
Stationaire drieklaauw	<b>SBF 3</b>  <ul style="list-style-type: none"> <li>▲ bijzonder geschikt voor gebruik op een (3/5-assige) freesmachine en ronde werkstukken</li> <li>▲ passend op PNG- en MNG-nulpuntsystemen</li> </ul>	✓		✓
	 <ul style="list-style-type: none"> <li>▲ bijzonder geschikt voor gebruik op een (3/5-assige) freesmachine en ronde werkstukken</li> <li>▲ passend op PNG- en MNG-nulpuntsystemen</li> </ul>	✓		✓

type	omschrijving
Nulpuntsysteem mechanisch	<b>MNG</b>  <ul style="list-style-type: none"> <li>▲ allroundplaat voor elke machinetafel</li> </ul>
	<b>MNG mini</b>  <ul style="list-style-type: none"> <li>▲ Voor de opspanning van kleinere werkstukken</li> </ul>
	<b>PNG</b>  <ul style="list-style-type: none"> <li>▲ proceszekerheid door borging</li> </ul>
pneumatisch	
Opspanoren	 <ul style="list-style-type: none"> <li>▲ verhoging van de machine looptijden</li> </ul>

## Handmatige machineklem

Boormachine klem	<b>HSG</b>  <ul style="list-style-type: none"> <li>▲ snelle bekkenverstelling, compact en nauwkeurig</li> </ul>
------------------	--

	bekbreedte in mm	lengte van basis in mm	max. spanbereik in mm	rechthoekige werkstukken	onregelmatige werkstukken	ronde werkstukken	max. spankracht in kN	pagina
	80	300	102				25	101-110
	125	320+390+460 530+600+670+740	114+149+184 219+254+289+324	✓	✓	✓	40	
	40 65 90	260 -650	524	✓	✓	✓	30	111-124
		Ø 200	SB-H-bekken 6-180			✓	100	125-130
		Ø 315	SB-H-bekken 12-420			✓	180	
	mechanisch		pneumatisch			Opmerkingen:		pagina
	✓							134-148
	✓							149-151
			✓					152-163
	✓					Deze artikelen vindt u in onze online shop via <a href="http://cuttingtools.ceratizit.com">cuttingtools.ceratizit.com</a>		 
	✓							131-133



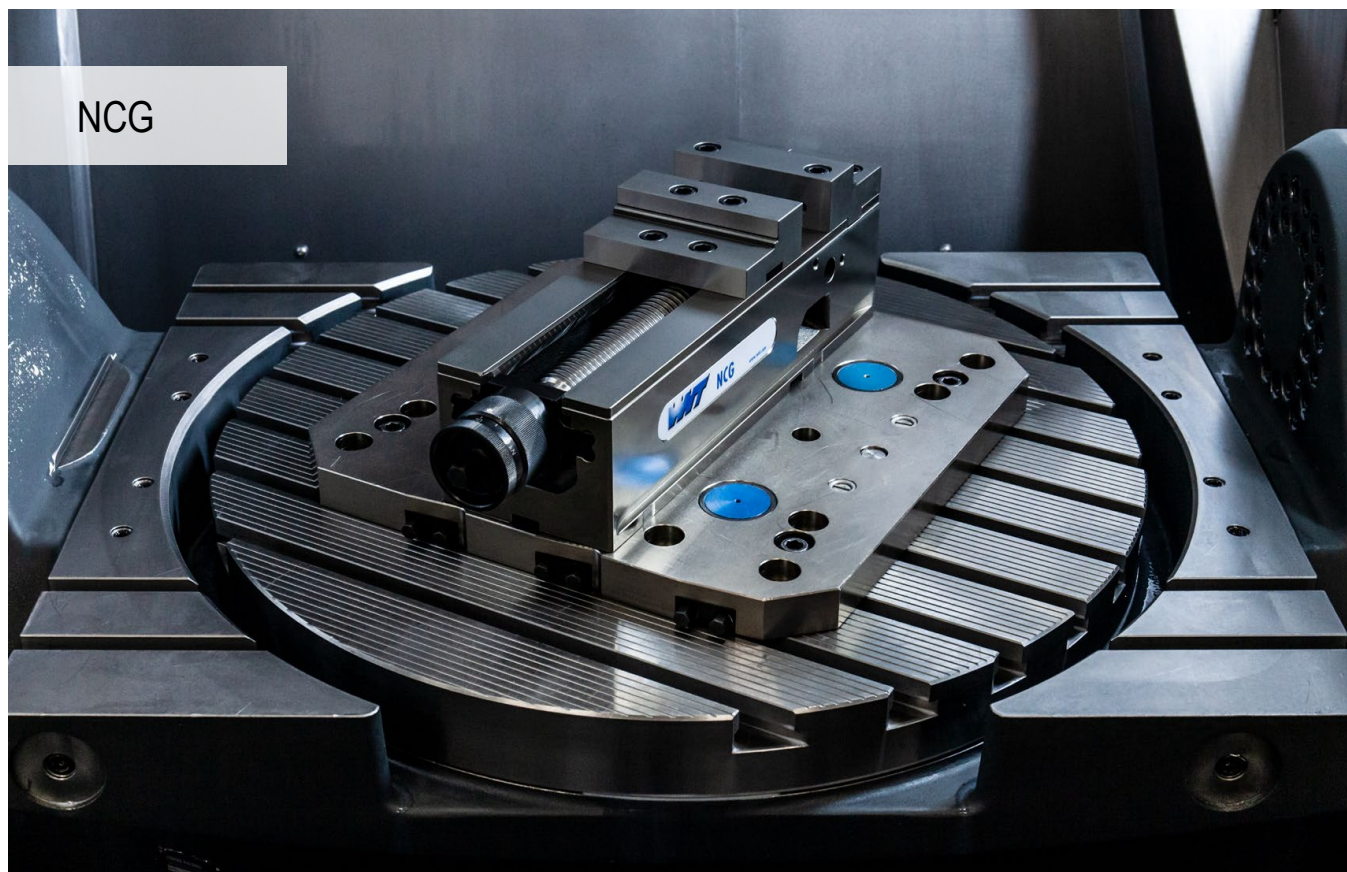

## Klemmen met systeem

Modulair opgebouwde machineklem als systeem met klemming op trek.  
Unieke, gepatenteerde snelspanhendel met mechanische krachtversterking en minimale insteltijden.

### Uw voordelen:

- ▲ snelverstelling door middel van handwiel
- ▲ snel positioneren op de machinetafel met MNG zonder pallet
- ▲ spankracht traploos instelbaar 4 – 40 kN
- ▲ 160° snelklemming
- ▲ eenvoudiger en sneller wisselen van bekken met 4 bouten
- ▲ eenvoudig te reinigen door snelle demontage van de complete spindeleenheid
- ▲ omvangrijk modulair bekkenprogramma



### Opspannen / uitlijnen:



Opspannen met twee pasbouten Ø 12<sub>17</sub> / M12  
(NCG 100) Artikel-nr. 80 890 313 of Ø 16<sub>95</sub> / M16  
(NCG 125 / 160) Artikel-nr. 80 890 314



Positionering door nauwkeurige pasblokken 20<sup>H7</sup>  
in de basis en opspannen met klemvingers



Uitlijnen en opspannen met nulpunt  
spansysteem MNG (2-3 opnamepennen)

## SoloClamp – NCG

- ▲ NC-snelspanner met combi-bekken Plus
- ▲ door extra draadgaten is het mogelijk opzetbekken met hoogte 18 mm en 40 mm te gebruiken

**leveromvang:**

NC-snelspanner, incl. 4 klemvingers, 2 combibekken Plus, spanhendel

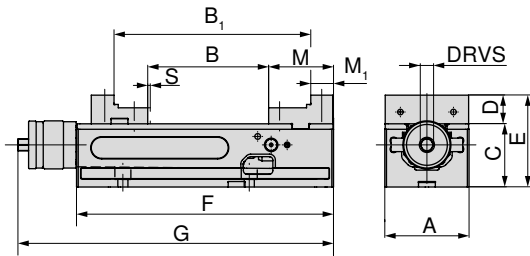

A	B	B <sub>1</sub>	C <sub>-0.02</sub>	D	E	F	G	M	M <sub>1</sub>	S	DRVS	MXC	WT	80 890 ...	
mm	mm	mm	mm	mm	mm	mm	mm	mm	mm	mm	mm	kN	kg	EUR	Y4
125	0 - 212	96 - 307	100	39	139	390	457	89	39	3	14	4 - 40	34	3.110,00	12500

## SoloClamp – NCG

- ▲ NC-snelspanner met combinatie bekken
- ▲ snelle 160° hendelspanning
- ▲ snelle in- en uitbouw van de spindel
- ▲ S = spanweg

**leveromvang:**

NC-snelspanner, incl. 4 klemvingers, 2 combibekken(een zijde getrapd, een zijde glad), spanhendel

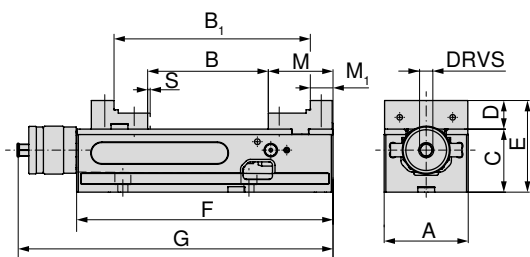
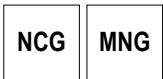

A	B	B <sub>1</sub>	C <sub>-0.02</sub>	D	E	F	G	M	M <sub>1</sub>	S	DRVS	MXC	WT	80 890 ...	
mm	mm	mm	mm	mm	mm	mm	mm	mm	mm	mm	mm	kN	kg	EUR	Y4
100	0 - 155	91 - 245	75	34	109	305	374	77	27	2,5	14	4 - 30	19	2.660,00	602
125	0 - 212	96 - 307	100	39	139	390	457	89	39	3	14	4 - 40	34	3.080,00	627
160	0 - 314	113 - 426	115	49	164	530	600	108	52	3	14	4 - 40	68	4.040,00	662

*Klemmengids*

Maten van de onderzijde	14	Systeem-toebehoren	16-21
MNG-/PNG nulpuntpansysteem	134-163	Algemeen toebehoren	164-183

## SoloClamp – NCG

- ▲ NC-snelspanner met standaard bekken
- ▲ snelle 160° hendelspanning
- ▲ snelle in- en uitbouw van de spindel
- ▲ S = spanweg

### leveromvang:

NC-snelspanner, incl. 4 klemvingers, 2 standaard bekken(een zijde glad, een zijde geribbeld), spanhendel

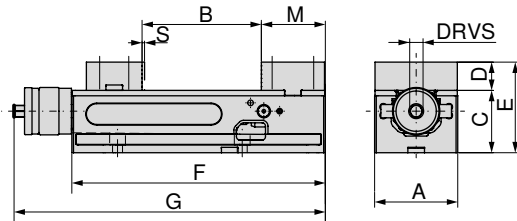

A	B	C <sub>-0.02</sub>	D	E	F	G	M	S	DRVS	MXC	WT	80 890 ...	
mm	mm	mm	mm	mm	mm	mm	mm	mm	mm	kN	kg	EUR	
100	0 - 155	75	34	109	305	374	77	2,5	14	4 - 30	19,5	2.580,00	600
125	0 - 212	100	39	139	390	457	89	3	14	4 - 40	35,0	3.010,00	625
160	0 - 314	115	49	164	530	600	108	3	14	4 - 40	70,0	3.960,00	660

## SoloClamp – NCG

- ▲ NC-snelspanner met adapter- en pendelbek
- ▲ snelle 160° hendelspanning
- ▲ snelle in- en uitbouw van de spindel
- ▲ S = spanweg
- ▲ eenvoudig ruwe delen spannen
- ▲ vrij positioneren van de 6-voudige bek (toebehoren)

### leveromvang:

NC-snelspanner (basis type NCG) met 1 vaste adapterplaat en 1 pendelbek, spanhendel, 4 klemvingers maar zonder 6-voudige bekken

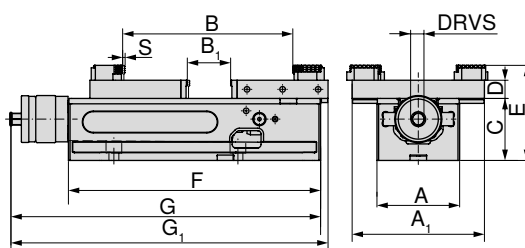
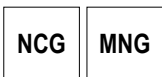

A	A <sub>1</sub>	B	B <sub>1</sub>	C <sub>-0.02</sub>	D	E	F	G	G <sub>1</sub>	S	DRVS	MXC	WT	80 890 ...	
mm	mm	mm	mm	mm	mm	mm	mm	mm	mm	mm	mm	kN	kg	EUR	
100	160	10 - 230	0 - 77	75	22	115	305	374	383	2,5	14	4 - 30	19	2.770,00	636
125	192	16 - 343	0 - 152	100	22	140	390	457	478	3	14	4 - 40	34	3.220,00	637
160	256	15 - 506	0 - 237	115	22	155	530	600	631	3	14	4 - 40	68	4.250,00	638

### Klemmengids

Maten van de onderzijde	14	Systeem-toebehoren	16-21
MNG-/PNG nulpuntspansysteem	134-163	Algemeen toebehoren	164-183

## SoloClamp – NCG 5A

- ▲ NC-snelspanner 5A met hoge bekken
- ▲ snelle 160° hendelspanning
- ▲ snelle in- en uitbouw van de spindel
- ▲ S = spanweg
- ▲ door optimale toegankelijkheid ideaal voor vijfzijdige bewerking
- ▲ bekken omkeerbaar voor het vergroten van het spanbereik
- ▲ basis 100 mm heeft 2 groeven voor het verzetten van de vaste bek
- ▲ basis 125 mm heeft 3 groeven voor het verzetten van de vaste bek

### leveromvang:

NC-snelspanner, incl. 2 hoge bekken, 2 getrapte gripbekken 5 mm, 1 spansleutel, 4 klemvingers

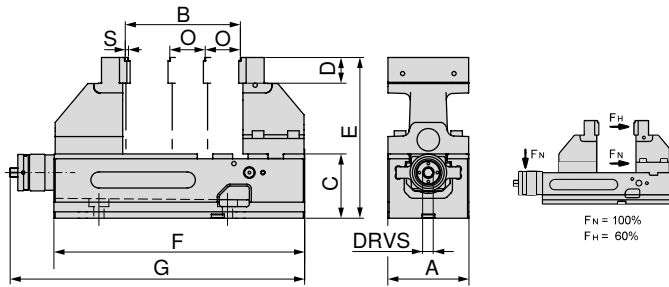
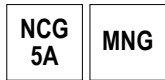

A	B	C	D	E	F	G	O	S	DRVS	MXC	WT
mm	mm	mm	mm	mm	mm	mm	mm	mm	mm	kN	kg
100	6 - 127	75	35	200	305	374	50	2,5	14	4 - 18 (30)	21,5
125	6 - 179	100	40	250	390	457	55	3	14	4 - 24 (40)	42,0

**80 890 ...**

**EUR  
Y4**

**3.210,00 605  
3.710,00 635**

### Klemmengids

Maten van de onderzijde	<b>14</b>	Maattabellen voor de verschillende bekken	<b>15</b>
Systeem-toebehoren	<b>16-21</b>	MNG-/PNG nulpuntspansysteem	<b>134-163</b>
Algemeen toebehoren	<b>164-183</b>		

## Maten van de onderzijde van NCG

### Basisbreedte 100 mm

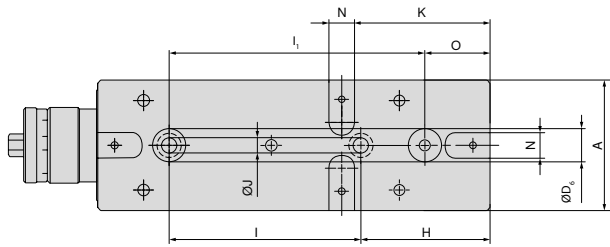

A	H	$I_{\pm 0,015}$	$J_{F7}$	K	$N_{H7}$	O	$I_1_{\pm 0,015}$	$D_6_{H7}$
mm	mm	mm	mm	mm	mm	mm	mm	mm
100	100	150	12	105	20	50	200	25

### Basisbreedte 125 mm

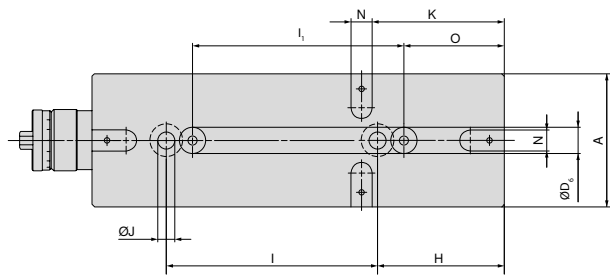

A	H	$I_{\pm 0,015}$	$J_{F7}$	K	$N_{H7}$	O	$I_1_{\pm 0,015}$	$D_6_{H7}$
mm	mm	mm	mm	mm	mm	mm	mm	mm
125	120	200	16	125	20	95	200	25

### Basisbreedte 160 mm

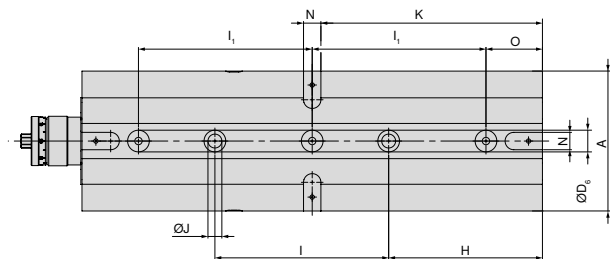

A	H	$I_{\pm 0,015}$	$J_{F7}$	K	$N_{H7}$	O	$I_1_{\pm 0,015}$	$D_6_{H7}$
mm	mm	mm	mm	mm	mm	mm	mm	mm
160	177	200	16	255	20	65	200	25

## NCG 5A maattabellen voor verschillende bekposities

### NCG 5A 100 mm

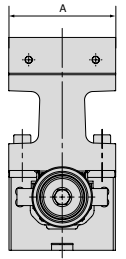
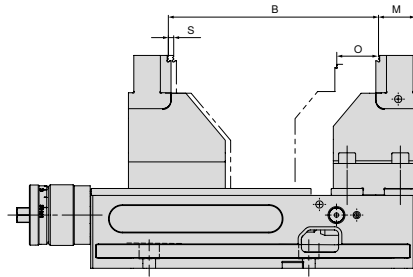
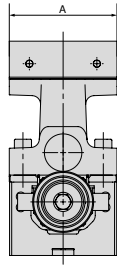
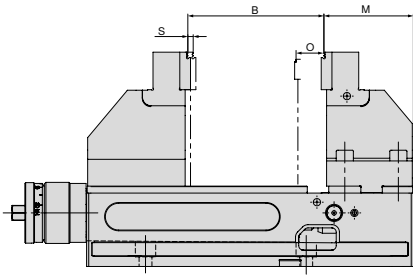

A	B	M	O	S
mm	mm	mm	mm	mm
100	6 - 127	84,5	50	2,5

A	B	M	O	S
mm	mm	mm	mm	mm
100	97 - 199	34,5	50	2,5

### NCG 5A 125 mm

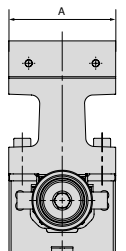
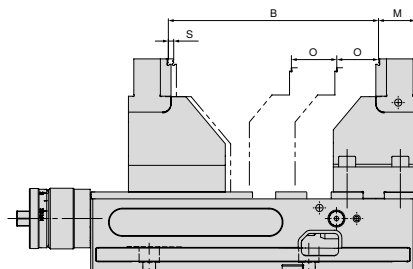
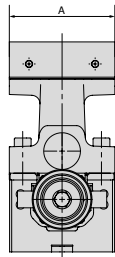
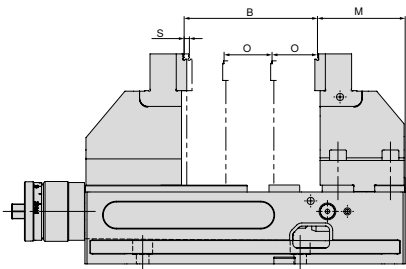

A	B	M	O	S
mm	mm	mm	mm	mm
125	6 - 182	91	55	3

A	B	M	O	S
mm	mm	mm	mm	mm
125	117 - 269	36	55	3

## Overzicht systeembekken

### Combi-bek Plus, vast

- ▲ voor vergroting van het spanbereik
- ▲ bekken gehard
- ▲ incl. bevestigingsbouten
- ▲ prijs per stuk

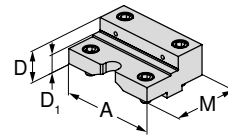

voor basisbreedte	A	A <sub>1</sub>	D	D <sub>1</sub>	D <sub>2</sub>	E	M	M <sub>1</sub>	M <sub>2</sub>	EUR	Y4	NCG	H5G / -S / -Z	X5G-Z / -S	ESG 4	ESG 5	HDG 2	ZSG 4	ZSG mini	DSG 4	Verro	HSG	
125	125		39,8	22			88			377,00	80 890 35100	●											

### Combi-bek Plus, los

- ▲ voor vergroting van het spanbereik
- ▲ bekken gehard
- ▲ incl. bevestigingsbouten
- ▲ prijs per stuk

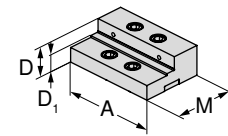

voor basisbreedte	A	A <sub>1</sub>	D	D <sub>1</sub>	D <sub>2</sub>	E	M	M <sub>1</sub>	M <sub>2</sub>	EUR	Y4	NCG	H5G / -S / -Z	X5G-Z / -S	ESG 4	ESG 5	HDG 2	ZSG 4	ZSG mini	DSG 4	Verro	HSG	
125	125		39,8	22			82			377,00	80 890 35200	●											

### Standaard bek, vast

- ▲ 1 zijde glad, 1 zijde geprofileerd
- ▲ incl. bevestigingsbouten
- ▲ prijs per stuk

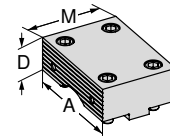

voor basisbreedte	A	A <sub>1</sub>	D	D <sub>1</sub>	D <sub>2</sub>	E	M	M <sub>1</sub>	M <sub>2</sub>	EUR	Y4	NCG	H5G / -S / -Z	X5G-Z / -S	ESG 4	ESG 5	HDG 2	ZSG 4	ZSG mini	DSG 4	Verro	HSG	
100	100		34				76			247,00	80 890 323	●											
125	125		39				88			323,00	80 890 324	●											
160	160		49				108			407,00	80 890 325	●											

### Standaard bek, los

- ▲ 1 zijde glad, 1 zijde geprofileerd
- ▲ incl. bevestigingsbouten
- ▲ prijs per stuk

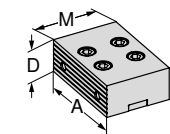

voor basisbreedte	A	A <sub>1</sub>	D	D <sub>1</sub>	D <sub>2</sub>	E	M	M <sub>1</sub>	M <sub>2</sub>	EUR	Y4	NCG	H5G / -S / -Z	X5G-Z / -S	ESG 4	ESG 5	HDG 2	ZSG 4	ZSG mini	DSG 4	Verro	HSG	
100	100		34				67			247,00	80 890 327	●											
125	125		39				82			323,00	80 890 328	●											
160	160		49				108			407,00	80 890 329	●											

## Overzicht systeembekken

### Combi-bek, vast

- ▲ voor vergroting van het spanbereik
- ▲ bekken gehard
- ▲ incl. bevestigingsbouten
- ▲ prijs per stuk

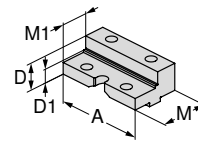

voor basisbreedte	A	A <sub>1</sub>	D	D <sub>1</sub>	D <sub>2</sub>	E	M	M <sub>1</sub>	M <sub>2</sub>	EUR	Y4	NCG	H5G / -S / -Z	X5G-Z / -S	ESG 4	ESG 5	HDC 2	ZSG 4	ZSG mini	DSG 4	Versto	HSG		
100	100		34	23			76	50		285,00	80 890 343	●												
125	125		39	25			88	50		363,00	80 890 344	●												
160	160		49	28			108	56		446,00	80 890 342	●												

### Combi-bek, los

- ▲ voor vergroting van het spanbereik
- ▲ bekken gehard
- ▲ incl. bevestigingsbouten
- ▲ prijs per stuk

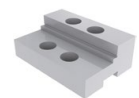
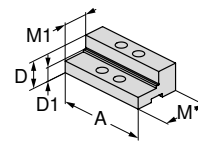

voor basisbreedte	A	A <sub>1</sub>	D	D <sub>1</sub>	D <sub>2</sub>	E	M	M <sub>1</sub>	M <sub>2</sub>	EUR	Y4	NCG	H5G / -S / -Z	X5G-Z / -S	ESG 4	ESG 5	HDC 2	ZSG 4	ZSG mini	DSG 4	Versto	HSG			
100	100		34	23			67	40		285,00	80 890 347	●													
125	125		39	25			82	45		363,00	80 890 348	●													
160	160		49	28			108	56		446,00	80 890 346	●													

### Zachte bek, staal, vast

- ▲ materiaal: 16MnCr5
- ▲ voor het maken van vormbekken (hardbaar)
- ▲ zonder bevestigingsbouten
- ▲ prijs per stuk

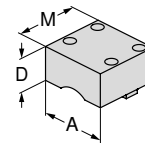

voor basisbreedte	A	A <sub>1</sub>	D	D <sub>1</sub>	D <sub>2</sub>	E	M	M <sub>1</sub>	M <sub>2</sub>	EUR	Y4	NCG	H5G / -S / -Z	X5G-Z / -S	ESG 4	ESG 5	HDC 2	ZSG 4	ZSG mini	DSG 4	Versto	HSG			
100	100		50				95			143,40	80 890 763	●													
125	125		50				110			149,70	80 890 764	●													

### Zachte bek, staal, los

- ▲ materiaal: 16MnCr5
- ▲ voor het maken van vormbekken (hardbaar)
- ▲ zonder bevestigingsbouten
- ▲ prijs per stuk

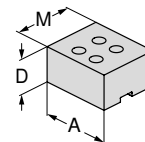

voor basisbreedte	A	A <sub>1</sub>	D	D <sub>1</sub>	D <sub>2</sub>	E	M	M <sub>1</sub>	M <sub>2</sub>	EUR	Y4	NCG	H5G / -S / -Z	X5G-Z / -S	ESG 4	ESG 5	HDC 2	ZSG 4	ZSG mini	DSG 4	Versto	HSG			
100	100		50				85			143,90	80 890 767	●													
125	125		50				100			151,10	80 890 768	●													



## Overzicht systeembekken

### 5A-bek, vast

- ▲ prijs per stuk
- ▲ met getrapte gripbek 5 mm

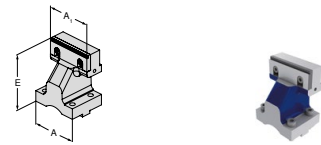

voor basisbreedte	A	A <sub>1</sub>	D	D <sub>1</sub>	D <sub>2</sub>	E	M	M <sub>1</sub>	M <sub>2</sub>	EUR	Y4	NCG	H5G / -S / -Z	X5G-Z / -S	ESG 4	ESG 5	HDG 2	HDG 4	ZSG 4	ZSG mini	DSG 4	Verso	HSG	
100	100	100				125				554,00	80 890 364	●												
125	125	125				150				666,00	80 890 366	●												

### 5A-bek, los

- ▲ prijs per stuk
- ▲ met getrapte gripbek 5 mm

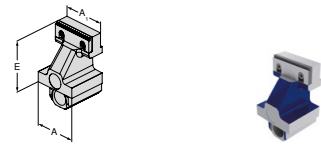

voor basisbreedte	A	A <sub>1</sub>	D	D <sub>1</sub>	D <sub>2</sub>	E	M	M <sub>1</sub>	M <sub>2</sub>	EUR	Y4	NCG	H5G / -S / -Z	X5G-Z / -S	ESG 4	ESG 5	HDG 2	HDG 4	ZSG 4	ZSG mini	DSG 4	Verso	HSG	
100	100	100				125				589,00	80 890 365	●												
125	125	125				150				730,00	80 890 367	●												

### Adapterplaat, vast

- ▲ voor opname van 6-voudige bekken
- ▲ prijs per stuk
- ▲ incl. 6 afdekschroeven

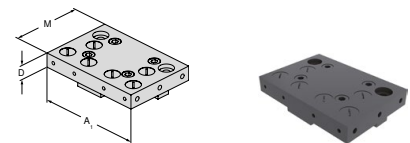

voor basisbreedte	A	A <sub>1</sub>	D	D <sub>1</sub>	D <sub>2</sub>	E	M	M <sub>1</sub>	M <sub>2</sub>	EUR	Y4	NCG	H5G / -S / -Z	X5G-Z / -S	ESG 4	ESG 5	HDG 2	HDG 4	ZSG 4	ZSG mini	DSG 4	Verso	HSG	
100	100	160	22				110			278,00	80 890 321	●												
125	125	192	22				130			397,00	80 890 337	●												
160	160	256	22				170			521,00	80 890 339	●												

### Pendelbek, los

- ▲ voor opname van 6-voudige bekken
- ▲ prijs per stuk
- ▲ incl. 6 afdekschroeven (bij A = 100 mm, 4 stuks)

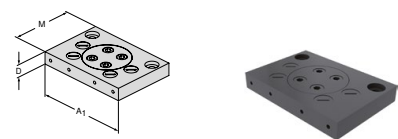

voor basisbreedte	A	A <sub>1</sub>	D	D <sub>1</sub>	D <sub>2</sub>	E	M	M <sub>1</sub>	M <sub>2</sub>	EUR	Y4	NCG	H5G / -S / -Z	X5G-Z / -S	ESG 4	ESG 5	HDG 2	HDG 4	ZSG 4	ZSG mini	DSG 4	Verso	HSG	
100	100	160	22				110			401,00	80 890 322	●												
125	125	192	22				130			472,00	80 890 338	●												
160	160	256	22				170			582,00	80 890 340	●												

# Overzicht systeembekken

## 6-voudige bek

- ▲ 1 = glad, wolframcarbide gecoat
- ▲ 2 = grip met trap 3 mm
- ▲ 3 = grip met trap 8 mm
- ▲ 4 = grip met trap 18 mm
- ▲ 5 = grip met trap 8 mm
- ▲ 6 = grip rond
- ▲  $M_{max} = 60 \text{ Nm}$
- ▲ incl. bevestigingsbout

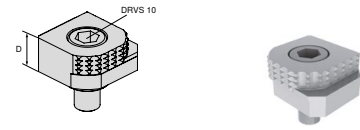

voor basisbreedte	A	A <sub>1</sub>	D	D <sub>1</sub>	D <sub>2</sub>	E	M	M <sub>1</sub>	M <sub>2</sub>	EUR	Y4	NCG	H5G / -S / -Z	X5G-Z / -S	ESG 4	ESG 5	HDG 2	ZSG 4	ZSG mini	DSG 4	Verso	HSG
			18							80,60	80 892 246	●	●	●	●			●		●	●	

## 6-voudige bek

- ▲ 1 = glad
- ▲ 2 = carbide grip
- ▲ 3 = carbide grip met trap 3 mm
- ▲ 4 = carbide grip met trap 8 mm
- ▲ 5 = carbide grip rond met trap 8 mm
- ▲ 6 = carbide grip rond
- ▲ incl. bevestigingsbout

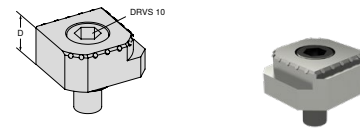

voor basisbreedte	A	A <sub>1</sub>	D	D <sub>1</sub>	D <sub>2</sub>	E	M	M <sub>1</sub>	M <sub>2</sub>	EUR	Y4	NCG	H5G / -S / -Z	X5G-Z / -S	ESG 4	ESG 5	HDG 2	ZSG 4	ZSG mini	DSG 4	Verso	HSG
			18							117,00	80 890 35300	●	●	●	●			●		●	●	

## Overzicht systeem-toebehoren

### Spindelmoer

▲ voor ombouw van de NCG 5AC naar het type NCG

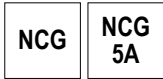

		80 890 ...	
voor breedte mm		EUR Y4	
100		186,00	385
125		197,00	387
160		224,00	389

### Handgreep

▲ voor eenvoudig en veilig transporteren

leveromvang:

1 st. handgreep incl. bevestigingsschroeven

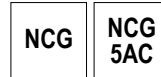

		80 890 ...	
voor breedte mm		EUR Y4	
100/125		18,20	685

### Trekstangverlenging

▲ voor het verbinden van 2 NCG-klemmen

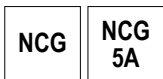

		80 890 ...	
voor breedte mm	B mm	EUR Y4	
100	305 - 460	318,00	460
125	390 - 602	349,00	470

### Beschermplaat

▲ voor losse standaardbekken,  
combibekken en combibekken-Plus

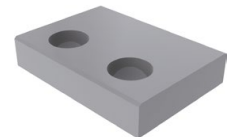
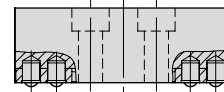

		80 890 ...	
voor breedte mm		EUR Y4	
100		4,60	010
125		3,50	012
160		35,00	013

### Afdekplaten set

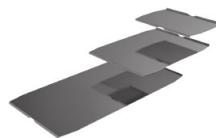
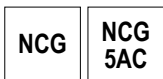

		80 890 ...	
voor breedte mm		EUR Y4	
100		27,10	442
125		31,00	443
160		32,40	444

### Verend drukstuk voor beschermplaat



		80 890 ...	
voor breedte mm		EUR Y4	
100/125		2,30	008
160		2,30	014

## Overzicht systeem-toebehoren

### Spansleutel

▲ incl. toebehoren

NCG	NCG 5A
H5G	



voor breedte		80 890 ...	
mm	DRVS	EUR	
100/125/160	mm	Y4	
	14	128,00	501

### Snелverstelling

▲ voor snelle spanbreedteverstelling  
met afneembare handgreep

NCG	NCG 5AC
-----	------------



voor breedte		80 890 ...	
mm		EUR	
100		Y4	
125/160		63,20	550
		75,10	551

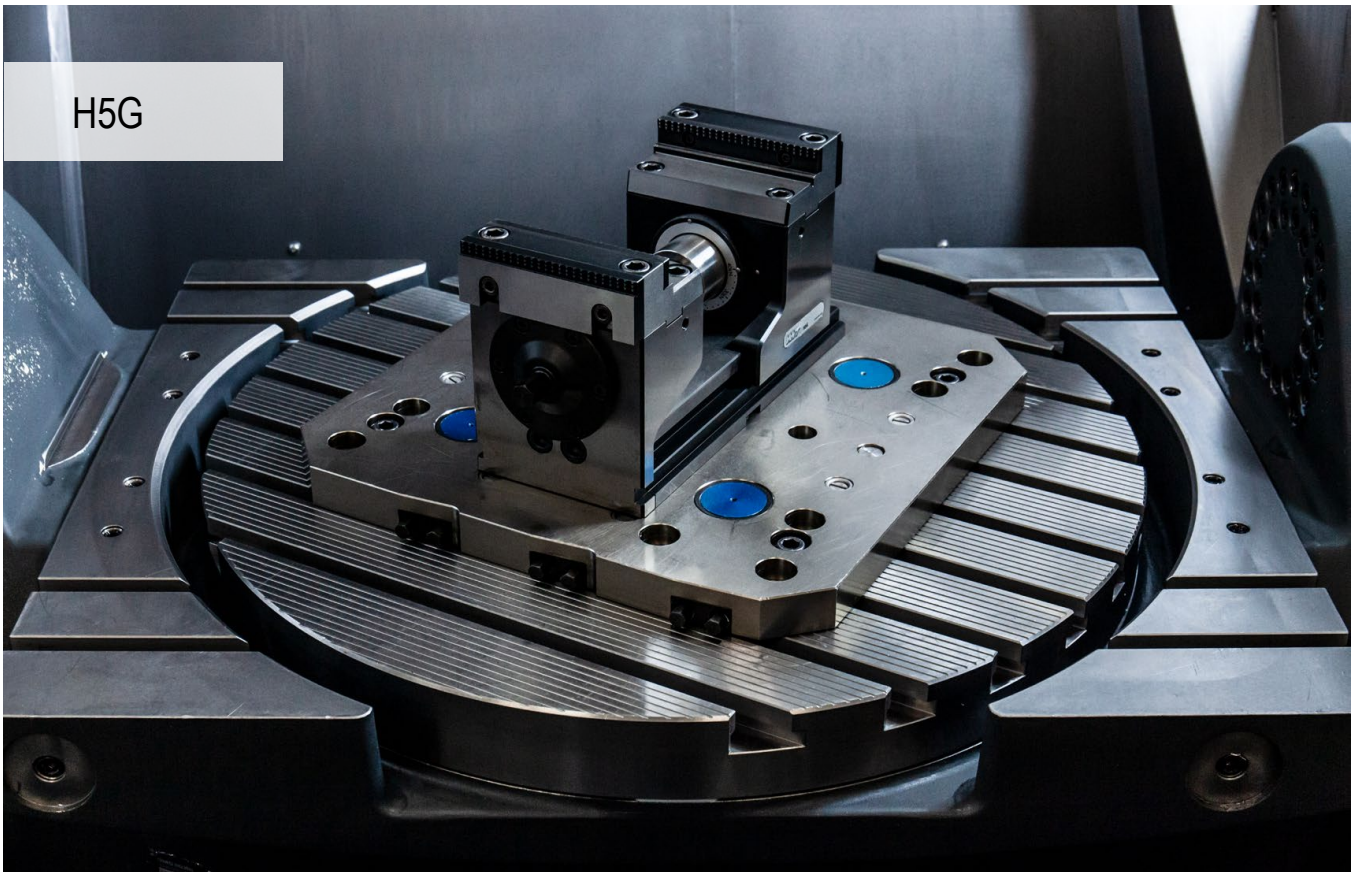

## Spansysteem 5-assen geoptimaliseerd

Het krachtversterkte spansysteem voor de „echte“ 5-assen complete- en simultaanbewerking. 1- en 2-zijdenbewerking met klemmen op trek en 40 kN direct aan het werkstuk.

### Uw voordelen:

- ▲ snelle ombouw – in enkele seconden kan het complete spanbereik veresteld worden
- ▲ snel positioneren op de machinetafel met MNG zonder tussenplaat
- ▲ spankracht traploos instelbaar 4 – 40 kN
- ▲ 160° snelklemming
- ▲ bekken draaien – eenvoudig en snel bekken wisselen met 4 bouten
- ▲ eenvoudig schoonmaken, spindel compleet beschermd
- ▲ omvangrijk modulair bekkenprogramma



### Opspannen / uitlijnen:

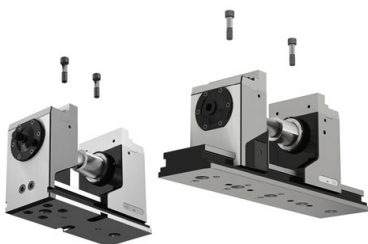

Opspannen met twee pasbouten Ø 12<sub>17</sub> / M12  
Artikel-nr. 80 895 019



Uitlijning door precisie pasblokken 20<sup>H7</sup> in de basis (H5G) voor 14 / 16 / 18 mm T-gleuf van de machinetafel. Opspannen met klemvingers.



Uitlijnen en opspannen met nulpunt spansysteem MNG (2-3 opnamepennen).  
**Optioneel:** Positioneer- en bevestigingsgaten naar wens van de klant.

## Uitlijning van verlenging:



- ▲ verlenging los monteren
- ▲ afstand tot basis 0,2 – 10 mm
- ▲ schuif de losse bek zo dat deze beide bases overlapt
- ▲ verlenging parallel aan de basis uitlijnen
- ▲ verlenging bevestigen

## Montage van trekstang verlenging:

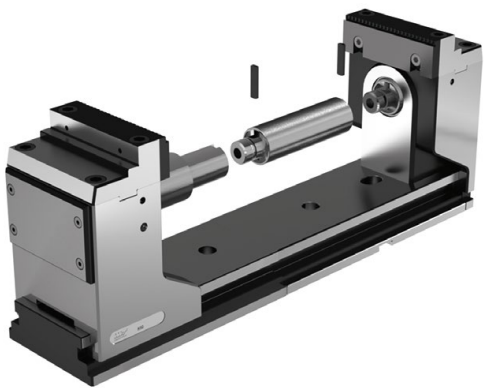

- ▲ verlenging monteren (uitlijning zie boven)
- ▲ trekstang verlenging op spindel schroeven
- ▲ plaats de eerste verdraaiblokkering
- ▲ schuif de losse bek op de verlenging
- ▲ verlengde trekstang met vaste bek verbinden
- ▲ plaats de tweede verdraaiblokkering

## Principe van verplaatsbare vaste bek:

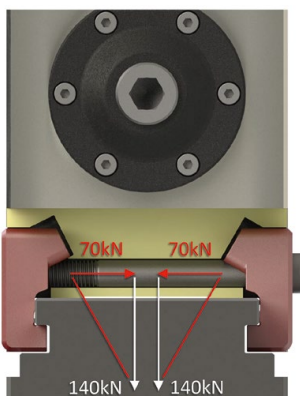

dubbel werkende bout = dubbele kracht  
schuin vlak = dubbele kracht

Bij de H5G-Z en H5G-Z-S kunnen beide bekken naar believen worden verschoven. De verplaatsbare vaste bek kan door middel van 1 of 2 schroeven (1 = H5G-Z / 2 = H5G-Z-S) op elke willekeurige positie op de basis geklemd worden (bouten met 90 Nm vastzetten). De klemkracht van de vaste bek is nagenoeg identiek aan die van de H5G, welke met vier bouten bevestigd is.

## SoloClamp – H5G

- ▲ 5-As krachtspanner met snelverstelling, hoogte 174 mm
- ▲ handkruk snelspanning
- ▲ spanning op trek met bovenliggende verstelbare spindel
- ▲ 100 % ingekapseld
- ▲ klem met langs- en dwarsgroeven alsmede pasgaten 20 H7 en pasboringen Ø 12 F7 uitgevoerd

### leveromvang:

machineklem incl. 4 klemvingers, handkruk en spansleutel

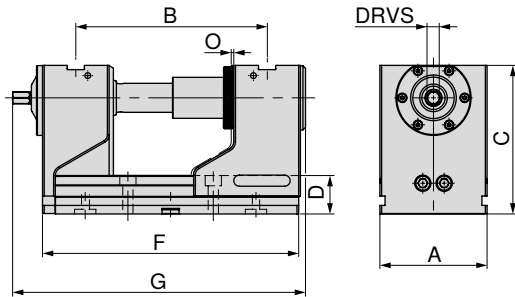

A	B	C	D	F	G	O	DRVS	MXC	WT	80 898 ...	
mm	mm	mm	mm	mm	mm	mm	mm	kN	kg	EUR	
125	97 - 223	174	45	300	336,5	1	14	40	30,2	Y4	3.180,00 125

## SoloClamp – H5G

- ▲ 5-As krachtspanner, lange uitvoering, hoogte 174 mm

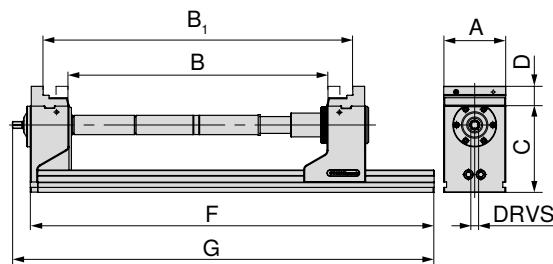
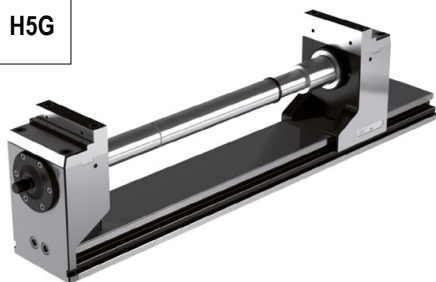

A	C	D	F	G	DRVS	spankracht
mm	mm	mm	mm	mm	mm	kN
125	174	40	815	851	14	40

B	B <sub>1</sub>	Artikelnummer
0 – 126	123 – 251	80 898 125
125 – 252	248 – 374	80 898 125 + 80 898 826 + 80 898 725
250 – 376	372 – 499	80 898 125 + 80 898 827 + 80 898 725
375 – 501	498 – 624	80 898 125 + 80 898 826 + 80 898 827 + 80 898 725
500 – 626	622 – 749	80 898 125 + 2 x 80 898 827 + 80 898 725



De H5G 125 mm kan maximaal met 2 trekstangverlengingen van elk 250 mm worden uitgebreid. Per verlenging ca. 10 % spankrachtverlies. Grondplaten in lange uitvoering met gewenst boorpatroon alleen **op aanvraag verkrijgbaar**.

### Klemmengids

Maten van de onderzijde	27	Maattabellen voor de verschillende bekken	28–32
Systeem-toebehoren	33–36	MNG-/PNG nulpuntspansysteem	134–163
Algemeen toebehoren	164–183		

## SoloClamp – H5G-S

- ▲ 5-As krachtspanner met snelverstelling, hoogte 125 mm
- ▲ handkruk snelspanning
- ▲ spanning op trek met bovenliggende verstelbare spindel
- ▲ 100 % gekapseld
- ▲ lengte F = 300 mm met centrering Ø 25 H7
- ▲ lengte F = 265 mm met centrering Ø 32 H6
- ▲ klem met langs- en dwarsgroeven alsmede pasgaten 20 H7 en pasboringen Ø 12 F7 uitgevoerd

### leveromvang:

machineklem incl. 4 klemvingers, handkruk en spansleutel

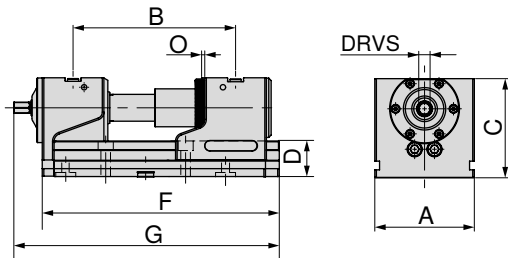

A	B	C	D	F	G	O	DRVS	MXC	WT	80 898 ...	
mm	mm	mm	mm	mm	mm	mm	mm	kN	kg	EUR	
125	97 - 186	125	45	265	301,5	1	14	40	21,0	2.910,00	123 <sup>1)</sup>
125	97 - 223	125	45	300	336,5	1	14	40	22,6	2.980,00	124

1) niet geschikt voor MNG

## SoloClamp – H5G-S

- ▲ 5-As krachtspanner, lange uitvoering, hoogte 125 mm

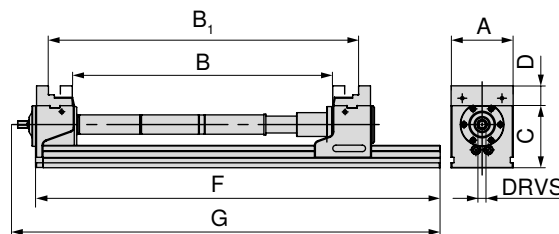

A	C	D	F	G	DRVS	spankracht
mm	mm	mm	mm	mm	mm	kN
125	125	40	815	851	14	40

B	B <sub>1</sub>	Artikelnummer
0 – 126	123 – 250	80 898 124
125 – 251	248 – 374	80 898 124 + 80 898 826 + 80 898 725
250 – 376	372 – 499	80 898 124 + 80 898 827 + 80 898 725
375 – 501	498 – 624	80 898 124 + 80 898 826 + 80 898 827 + 80 898 725
500 – 626	622 – 749	80 898 124 + 2 x 80 898 827 + 80 898 725



De H5G-S 125 mm kan maximaal met 2 trekstangverlengingen van elk 250 mm worden uitgebreid. Per verlenging ca. 10 % spankrachtverlies. Grondplaten in lange uitvoering met gewenst boorpatroon alleen **op aanvraag verkrijgbaar**.

### Klemmengids

Maten van de onderzijde	27	Maattabellen voor de verschillende bekken	28–32
Systeem-toebehoren	33–36	MNG-/PNG nulpuntspansysteem	134–163
Algemeen toebehoren	164–183		



## SoloClamp – H5G-Z

- ▲ 5-As krachtspanner met een verplaatsbare vaste bek, hoogte 174 mm
- ▲ handkruk snelspanning
- ▲ spanning op trek met een bovenliggende verstelbare spindel
- ▲ 100% gekapseld
- ▲ opspannen op de machinetafel is mogelijk met MNG/PNG of direct door de grondplaat

### leveromvang:

incl. spansleutel met inbusdop

H5G  
-Z

MNG

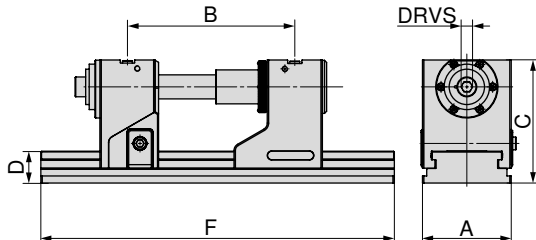

A	B $\pm 0,015$	C	D	F	DRVS	MXC	WT	80 907 ...	
mm	mm	mm	mm	mm	mm	kN	kg	EUR	Y4
125	131 - 246	174	45	330	14	40	32,5	3.590,00	12800
125	131 - 352	174	45	430	14	40	36,0	3.650,00	125
125	131 - 422	174	45	500	14	40	38,5	3.810,00	126
125	131 - 552	174	45	630	14	40	43,0	4.130,00	127



→ pagina 36

Hier vindt u de trekstangverlengingen, die moeten worden ingezet om de maximale spanbreedte te bereiken.

## SoloClamp – H5G-Z-S

- ▲ 5-As krachtspanner met een verplaatsbare vaste bek, hoogte 125 mm
- ▲ handkruk snelspanning
- ▲ spanning op trek met een bovenliggende verstelbare spindel
- ▲ 100% gekapseld
- ▲ opspannen op de machinetafel is mogelijk met MNG/PNG of direct door de grondplaat

### leveromvang:

incl. spansleutel met inbusdop

H5G  
-Z-S

MNG

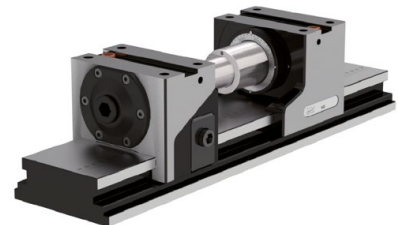
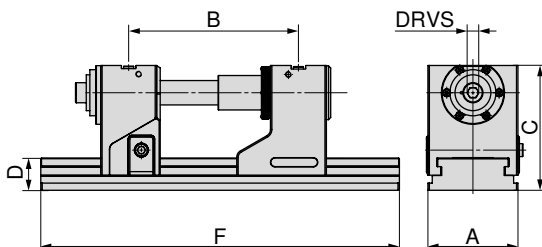

A	B $\pm 0,015$	C	D	F	DRVS	MXC	WT	80 907 ...	
mm	mm	mm	mm	mm	mm	kN	kg	EUR	Y4
125	131 - 246	125	45	330	14	40	24,5	3.380,00	22500
125	131 - 352	125	45	430	14	40	28,5	3.430,00	22600
125	131 - 422	125	45	500	14	40	30,5	3.610,00	22700
125	131 - 552	125	45	630	14	40	35,5	3.930,00	22800

## Maten van de onderzijde van H5G/H5G-Z

Basisbreedte 125 mm en lengte 265 mm

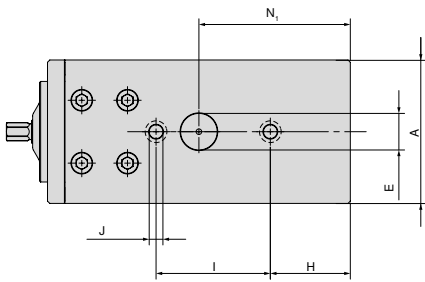

A	E <sub>H6</sub>	H	I <sub>±0,015</sub>	J <sub>F7</sub>	N <sub>1</sub>
mm	mm	mm	mm	mm	mm
125	32	70	100	12	132,5

Basisbreedte 125 mm en lengte 430 mm

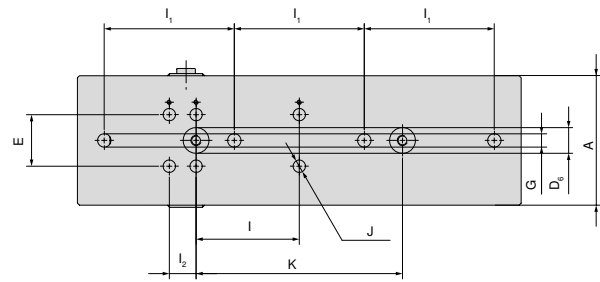

A	E <sub>±0,01</sub>	I <sub>1 ±0,3</sub>	I <sub>2</sub>	I <sub>±0,015</sub>	K <sub>±0,015</sub>	J <sub>H7</sub>	G	D <sub>6 H6</sub>
mm	mm	mm	mm	mm	mm	mm	mm	mm
125	50	126	26	100	200	12	13	25



H5G met lengte 265 mm is niet compatibel met MNG.

Basisbreedte 125 mm en lengte 300 mm

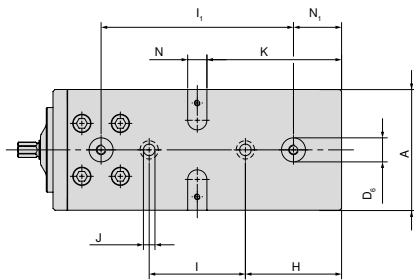

A	D <sub>6 H7</sub>	H	I <sub>±0,015</sub>	J <sub>F7</sub>	K	N <sub>H7</sub>	I <sub>1 ±0,015</sub>	N <sub>1</sub>
mm	mm	mm	mm	mm	mm	mm	mm	mm
125	25	100	100	12	140	20	200	50

Basisbreedte 125 mm en lengte 500 mm

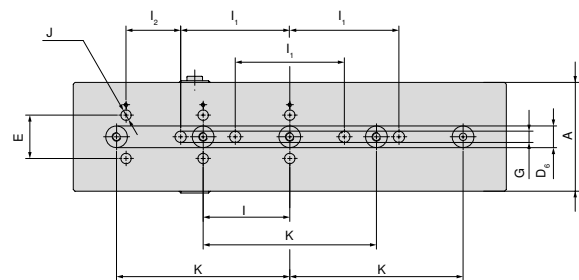

A	E <sub>±0,01</sub>	I <sub>1 ±0,3</sub>	I <sub>±0,015</sub>	K <sub>±0,015</sub>	I <sub>2</sub>	G	D <sub>6 H6</sub>	J <sub>H7</sub>
mm	mm	mm	mm	mm	mm	mm	mm	mm
125	50	126	100	200	63	13	25	12

Basisbreedte 125 mm en lengte 330 mm

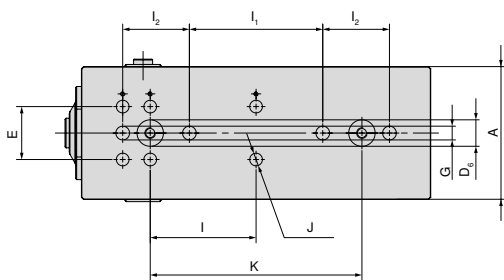

A	E <sub>±0,01</sub>	I <sub>±0,015</sub>	I <sub>2</sub>	I <sub>1 ±0,3</sub>	D <sub>6 H6</sub>	J <sub>H7</sub>	K <sub>±0,015</sub>	G
mm	mm	mm	mm	mm	mm	mm	mm	mm
125	50	100	26	126	25	12	200	13

Basisbreedte 125 mm en lengte 630 mm

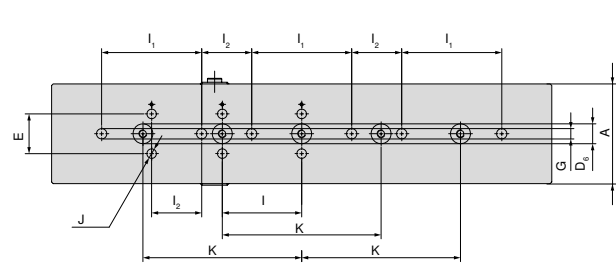

A	E <sub>±0,01</sub>	I <sub>1 ±0,3</sub>	I <sub>2</sub>	I <sub>±0,015</sub>	K <sub>±0,015</sub>	G	D <sub>6 H6</sub>	J <sub>H7</sub>
mm	mm	mm	mm	mm	mm	mm	mm	mm
125	50	126	63	100	200	13	25	12

# H5G/H5G-S – Maattabellen voor de verschillende bekken

met combi-bekken

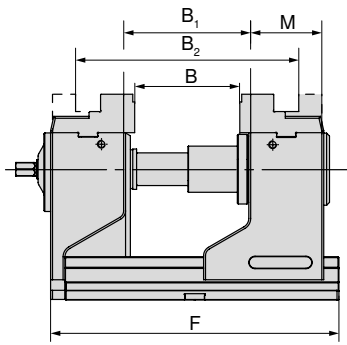

F	B	B <sub>1</sub>	B <sub>2</sub>	M	Artikel-nr.
mm	mm	mm	mm	mm	Systeembekken
265	0 - 89	22 - 112	123 - 212	76	<b>80 898 225</b>
300	0 - 126	22 - 149	123 - 249	76	<b>80 898 225</b>

H5G

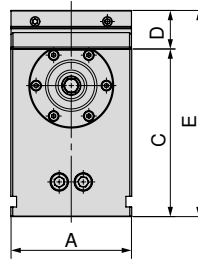

A	C	D	E
mm	mm	mm	mm
-	-	-	-
125	174	40	214

H5G-S

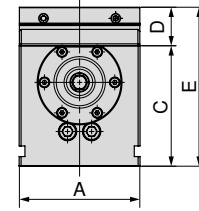

A	C	D	E
mm	mm	mm	mm
125	125	40	165
125	125	40	165

met 5A-opzetbekken, bekbreedte 65 mm

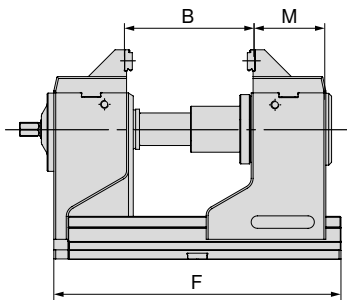

F	B	M	Artikel-nr.
mm	mm	mm	Systeembekken
265	16 - 105	79,5	<b>80 898 325</b>
300	16 - 142	79,5	<b>80 898 325</b>

H5G

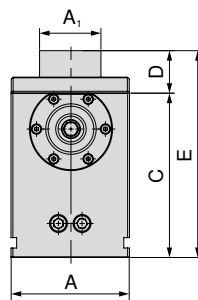

A	A <sub>1</sub>	C	D	E
mm	mm	mm	mm	mm
-	-	-	-	-
125	65	174	45	219

H5G-S

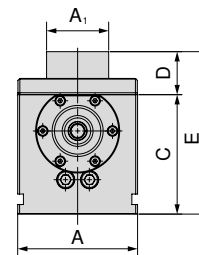

A	A <sub>1</sub>	C	D	E
mm	mm	mm	mm	mm
125	65	125	45	170
125	65	125	45	170

met 5A-opzetbekken, bekbreedte 125 mm

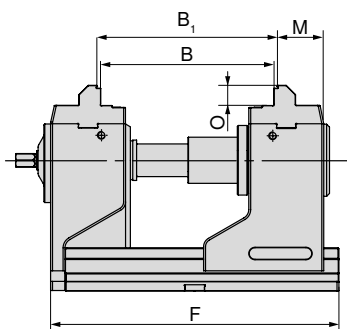

F	B	B <sub>1</sub>	O	M	Artikel-nr.
mm	mm	mm	mm	mm	Systeembekken
265	74 - 162	80 - 168	21	49	<b>80 907 300</b>
300	74 - 199	80 - 205	21	49	<b>80 907 300</b>

H5G

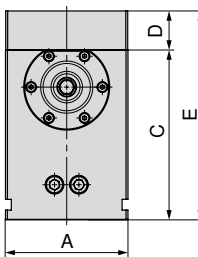

A	C	D	E
mm	mm	mm	mm
-	-	-	-
125	174	40	214

H5G-S

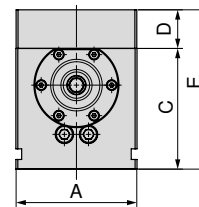

A	C	D	E
mm	mm	mm	mm
125	125	40	165
125	125	40	165

# H5G/H5G-S – Maattabellen voor de verschillende bekken

Met zachte bekken

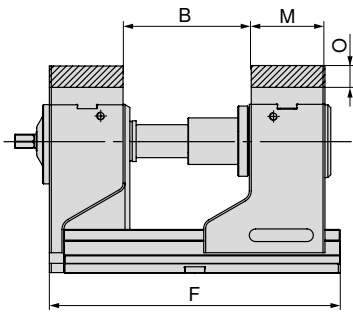

F	B	O	M	Artikel-nr.
mm	mm	mm	mm	Systeembekken
265	23 - 112	22	76	<b>80 898 625</b>
300	23 - 149	22	76	<b>80 898 625</b>

H5G

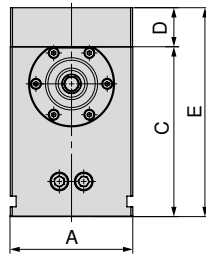

A	C	D	E
mm	mm	mm	mm
-	-	-	-
125	174	40	214

H5G-S

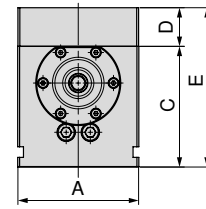

A	C	D	E
mm	mm	mm	mm
125	125	40	165
125	125	40	165

met gripbekken 3 mm

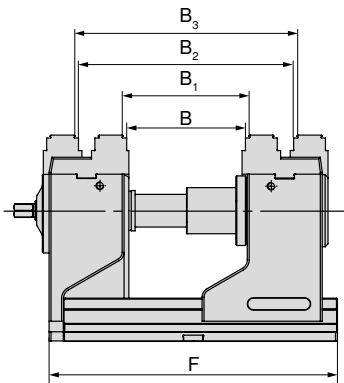

F	B	B <sub>1</sub>	B <sub>2</sub>	B <sub>3</sub>	Artikel-nr.
mm	mm	mm	mm	mm	Systeembekken
265	17 - 106	23 - 112	117 - 206	123 - 212	<b>80 898 35000</b>
300	17 - 140	23 - 146	117 - 240	123 - 246	<b>80 898 35000</b>

H5G

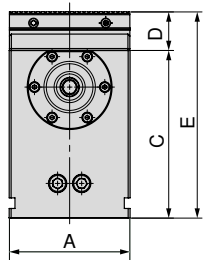

A	C	D	E
mm	mm	mm	mm
-	-	-	-
125	174	40	214

H5G-S

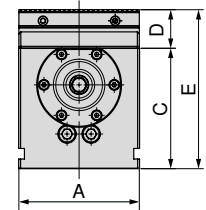

A	C	D	E
mm	mm	mm	mm
125	125	40	165
125	125	40	165

met pendelbekken en adapterplaten

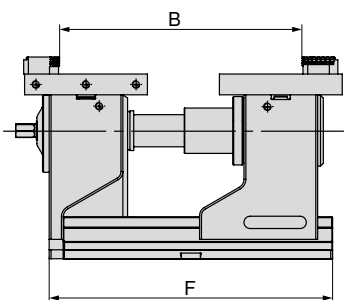

F	B	Artikel-nr.
mm	mm	Systeembekken
265	17 - 236	<b>80 898 525 + 80 898 425</b>
300	17 - 274	<b>80 898 525 + 80 898 425</b>

H5G

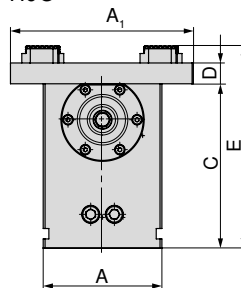

A	A <sub>1</sub>	C	D	E
mm	mm	mm	mm	mm
-	-	-	-	-
125	192	174	22	214

H5G-S

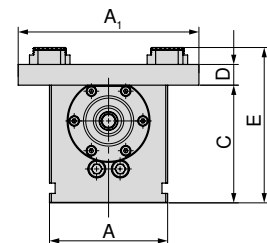

A	A <sub>1</sub>	C	D	E
mm	mm	mm	mm	mm
125	192	125	22	165
125	192	125	22	165

# H5G/H5G-S – Maattabellen voor de verschillende bekken

met 6-voudig-bekkensysteem

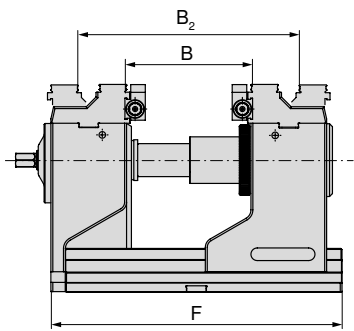

F	B	B <sub>2</sub>	O	M	Artikel-nr.
mm	mm	mm	mm	mm	Systeembekken
265	39-115	119-191	22	76	<b>80 898 230</b>
300	39-152	119-228	22	76	<b>80 898 230</b>

H5G

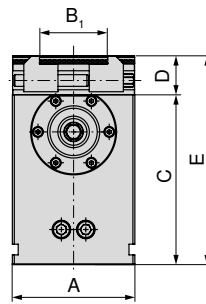

A	B <sub>1</sub>	C	D	E
mm	mm	mm	mm	mm
-	-	-	-	-
125	37-101	174	40	214

H5G-S

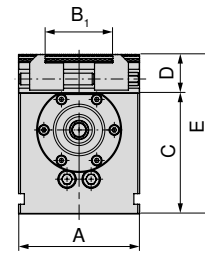

A	B <sub>1</sub>	C	D	E
mm	mm	mm	mm	mm
125	37-101	125	40	165
125	37-101	125	40	165

# H5G-Z/-S maattabellen voor de verschillende bekken

met combi-bekken

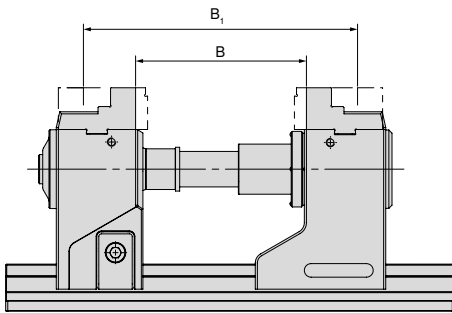

Varianten	B	B <sub>1</sub>	Artikel-nr.
	mm	mm	Systeembekken
H5G-Z	57-182	157-282	<b>80 898 225</b>
H5G-Z-S	47-172	147-272	<b>80 898 225</b>

H5G-Z

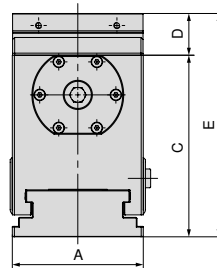

A	C	D	E
mm	mm	mm	mm
125	174	40	214
-	-	-	-

H5G-Z-S

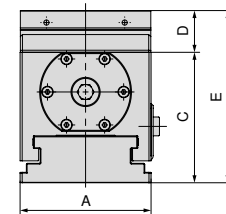

A	C	D	E
mm	mm	mm	mm
-	-	-	-
125	125	40	165

met 5A-getrapte opzetbek

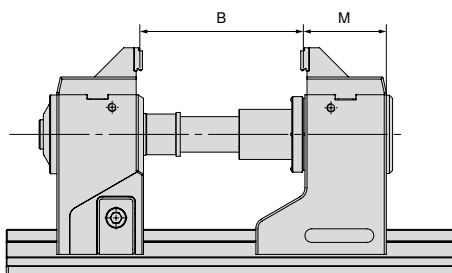

Varianten	B	M	Artikel-nr.
	mm	mm	Systeembekken
H5G-Z	50-175	74	<b>80 898 325</b>
H5G-Z-S	40-165	74	<b>80 898 325</b>

H5G-Z

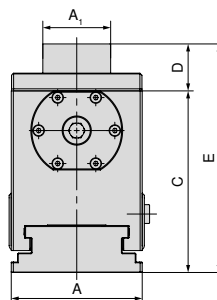

A	A <sub>1</sub>	C	D	E
mm	mm	mm	mm	mm
125	65	174	45	214
-	-	-	-	-

H5G-Z-S

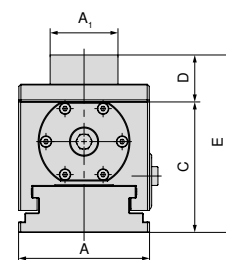

A	A <sub>1</sub>	C	D	E
mm	mm	mm	mm	mm
-	-	-	-	-
125	65	125	45	165

## H5G-Z/-S maattabellen voor de verschillende bekken

met gripbek 3 mm en gladde trap 16 mm

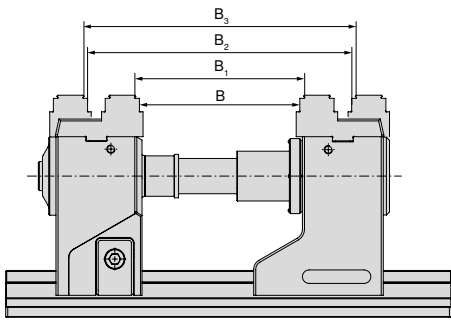

Varianten	B mm	B <sub>1</sub> mm	B <sub>2</sub> mm	B <sub>3</sub> mm	Artikel-nr. Systeembekken
H5G-Z	48-173	54-179	148-273	154-279	2 x <b>80 898 35000</b>
H5G-Z-S	38-173	44-169	138-263	144-269	2 x <b>80 898 35000</b>

H5G-Z

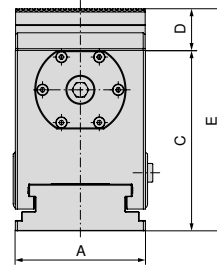

A mm	C mm	D mm	E mm
125	174	40	214
-	-	-	-

H5G-Z-S

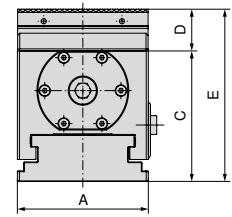

A mm	C mm	D mm	E mm
-	-	-	-
125	125	40	165

met 5A opzetbek, bekkbreedte 125 mm

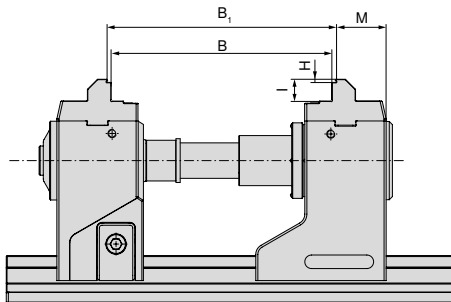

Varianten	B mm	B <sub>1</sub> mm	H mm	I mm	M mm	Artikel-nr. Systeembekken
H5G-Z	105-230	111-236	3	21	48,7	2 x <b>80 907 300</b>
H5G-Z-S	95-220	101-226	3	21	48,7	2 x <b>80 907 300</b>

H5G-Z

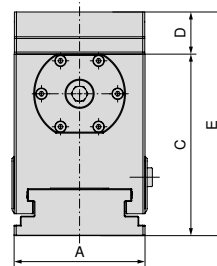

A mm	C mm	D mm	E mm
125	174	40	214
-	-	-	-

H5G-Z-S

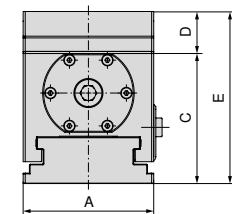

A mm	C mm	D mm	E mm
-	-	-	-
125	125	40	165

Met zachte bekken

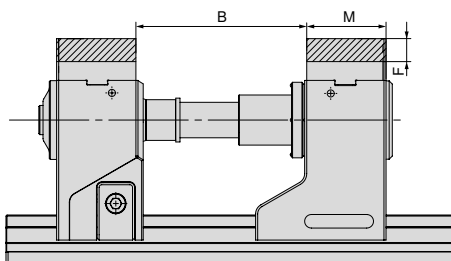

Varianten	B mm	F mm	M mm	Artikel-nr. Systeembekken
H5G-Z	57-182	22	76	<b>80 898 625</b>
H5G-Z-S	47-172	22	76	<b>80 898 625</b>

H5G-Z

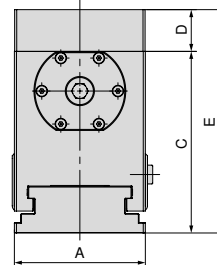

A mm	C mm	D mm	E mm
125	174	40	214
-	-	-	-

H5G-Z-S

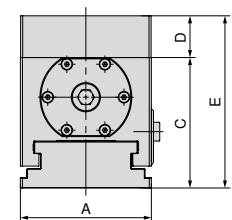

A mm	C mm	D mm	E mm
-	-	-	-
125	125	40	165

# H5G-Z/-S maattabellen voor de verschillende bekken

met pendelbekken en adapterplaten

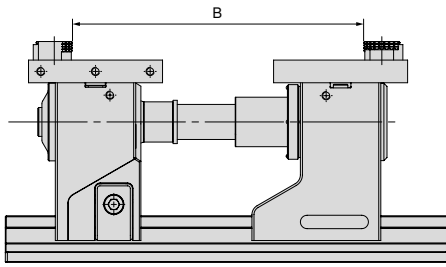

Varianten	B mm	Artikel-nr. Systeembekken
H5G-Z	11 - 300	<b>80 898 525 + 80 898 425</b>
H5G-Z-S	11 - 290	<b>80 898 525 + 80 898 425</b>

H5G-Z

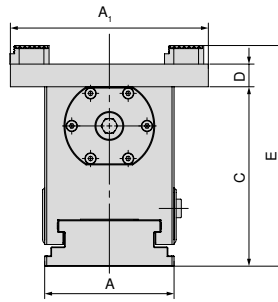

A mm	A <sub>1</sub> mm	C mm	D mm	E mm
125	192	174	40	214
-	-	-	-	-

H5G-Z-S

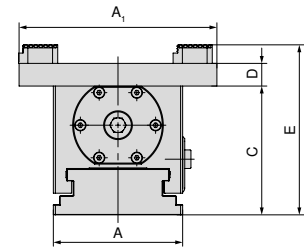

A mm	A <sub>1</sub> mm	C mm	D mm	E mm
-	-	-	-	-
125	192	125	40	165

met 6-voudig-bekkensysteem

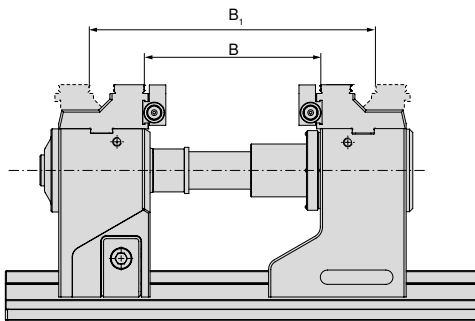

Varianten	B mm	B <sub>2</sub> mm	Artikel-nr. Systeembekken
H5G-Z	52-177	152-277	<b>80 898 230</b>
H5G-Z-S	42-167	142-267	<b>80 898 230</b>

H5G-Z

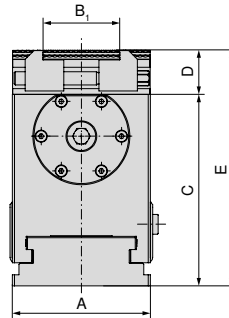

A mm	B <sub>1</sub> mm	C mm	D mm	E mm
125	37-101	174	40	214
-	-	-	-	-

H5G-Z-S

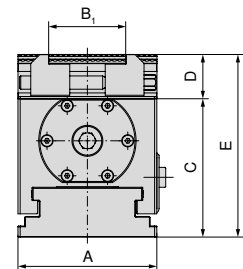

A mm	B <sub>1</sub> mm	C mm	D mm	E mm
-	-	-	-	-
125	37-101	125	40	165



De spanbereiken gelden ook voor basissen 500 mm en 630 mm. Grotere spanbereiken zijn mogelijk met de spindelverlengingen. Sommige van de opgegeven spanbereiken kunnen alleen met specifieke opzetbekken bereikt worden.

## Overzicht systeembekken

### 5A-getrapte opzetbek

- ▲ incl. opzetstuk 125/65 mm en 3 mm getrapte gripbek
- ▲ prijs per stuk

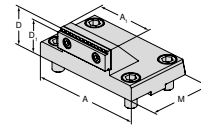

voor basisbreedte	A	A <sub>1</sub>	D	D <sub>1</sub>	D <sub>2</sub>	E	M	M <sub>1</sub>	M <sub>2</sub>
125	125	65	45	42			76		

EUR

Y4

377,00

80 898 325

NCG	H5G / -S / -Z	X5G-Z / -S	ESG 4	ESG 5	HDG 2	ZSG 4	ZSG mini	DSG 4	Verzo	HSG
	●									

### 5A-opzetbek

- ▲ verbeterde toegankelijkheid door afgeschuinde achterzijde
- ▲ prijs per stuk

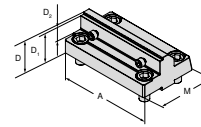

voor basisbreedte	A	A <sub>1</sub>	D	D <sub>1</sub>	D <sub>2</sub>	E	M	M <sub>1</sub>	M <sub>2</sub>
125	125		40	37	18		78		

EUR

Y4

354,00

80 907 300

NCG	H5G / -S / -Z	X5G-Z / -S	ESG 4	ESG 5	HDG 2	ZSG 4	ZSG mini	DSG 4	Verzo	HSG
	●									

### Combi-bek

- ▲ voor vergroting van het spanbereik
- ▲ prijs per stuk

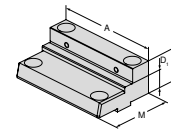

voor basisbreedte	A	A <sub>1</sub>	D	D <sub>1</sub>	D <sub>2</sub>	E	M	M <sub>1</sub>	M <sub>2</sub>
125	125		40	22			76		

EUR

Y4

377,00

80 898 225

NCG	H5G / -S / -Z	X5G-Z / -S	ESG 4	ESG 5	HDG 2	ZSG 4	ZSG mini	DSG 4	Verzo	HSG
	●									

### Zachte aluminium bek

- ▲ voor het vervaardigen van vormbekken
- ▲ prijs per stuk

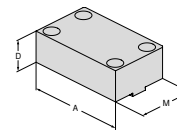

voor basisbreedte	A	A <sub>1</sub>	D	D <sub>1</sub>	D <sub>2</sub>	E	M	M <sub>1</sub>	M <sub>2</sub>
125	125		40				76		

EUR

Y4

111,00

80 898 625

NCG	H5G / -S / -Z	X5G-Z / -S	ESG 4	ESG 5	HDG 2	ZSG 4	ZSG mini	DSG 4	Verzo	HSG
	●									



## Overzicht systeembekken

Gripbek 3 mm, gladde trap 16 mm, beide zijden

▲ prijs per stuk

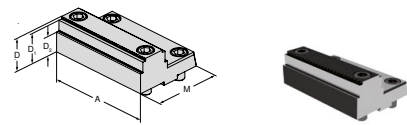

voor basisbreedte	A	A <sub>1</sub>	D	D <sub>1</sub>	D <sub>2</sub>	E	M	M <sub>1</sub>	M <sub>2</sub>	EUR	Y4	NCG	H5G / -S / -Z	X5G-Z / -S	ESG 4	ESG 5	HDG 2	ZSG 4	ZSG mini	DSG 4	Verso	HSG	
125	125		40	37	24		82,5			399,00			●										
											80 898 35000												

## Pendelbek, los

▲ voor opname van 6-voudige bekken

▲ prijs per stuk

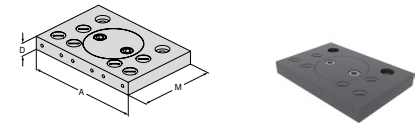

voor basisbreedte	A	A <sub>1</sub>	D	D <sub>1</sub>	D <sub>2</sub>	E	M	M <sub>1</sub>	M <sub>2</sub>	EUR	Y4	NCG	H5G / -S / -Z	X5G-Z / -S	ESG 4	ESG 5	HDG 2	ZSG 4	ZSG mini	DSG 4	Verso	HSG	
125	192		22				130			491,00			●										
											80 898 525												

## Adapterplaat vast

▲ voor opname van 6-voudige bekken

▲ prijs per stuk

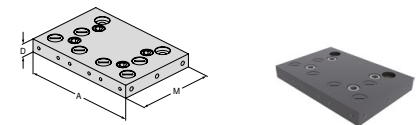

voor basisbreedte	A	A <sub>1</sub>	D	D <sub>1</sub>	D <sub>2</sub>	E	M	M <sub>1</sub>	M <sub>2</sub>	EUR	Y4	NCG	H5G / -S / -Z	X5G-Z / -S	ESG 4	ESG 5	HDG 2	ZSG 4	ZSG mini	DSG 4	Verso	HSG	
125	192		22				130			414,00			●										
											80 898 425												

## 6-voudige bek

▲ 1 = glad, wolframcarbide gecoat

▲ 2 = grip met trap 3 mm

▲ 3 = grip met trap 8 mm

▲ 4 = grip met trap 18 mm

▲ 5 = grip met trap 8 mm

▲ 6 = grip rond

▲ M<sub>max</sub> = 60 Nm

▲ incl. bevestigingsbout

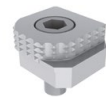
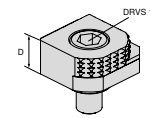

voor basisbreedte	A	A <sub>1</sub>	D	D <sub>1</sub>	D <sub>2</sub>	E	M	M <sub>1</sub>	M <sub>2</sub>	EUR	Y4	NCG	H5G / -S / -Z	X5G-Z / -S	ESG 4	ESG 5	HDG 2	ZSG 4	ZSG mini	DSG 4	Verso	HSG	
			18							80,60		●	●	●	●				●		●	●	
											80 892 246												

# Overzicht systeembekken

## 6-voudige bek

- ▲ 1 = glad
- ▲ 2 = carbide grip
- ▲ 3 = carbide grip met trap 3 mm
- ▲ 4 = carbide grip met trap 8 mm
- ▲ 5 = carbide grip rond met trap 8 mm
- ▲ 6 = carbide grip rond
- ▲ incl. bevestigingsbout

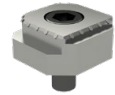
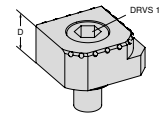

voor basisbreedte	A	A <sub>1</sub>	D	D <sub>1</sub>	D <sub>2</sub>	E	M	M <sub>1</sub>	M <sub>2</sub>	EUR	Y4	NCG	H5G / -S / -Z	X5G-Z / -S	ESG 4	ESG 5	HDG 2	ZSG 4	ZSG mini	DSG 4	Verso	HSG
			18							117,00	80 890 35300	●	●	●	●			●		●	●	

## 6-Voudig bekkensysteem voor bekbreedte 125 mm

**leveromvang:**

2 systeembekken met 2 paar dwarsbekken in T-gleufuitvoering incl. bevestigingsbouten

**H5G  
-S**

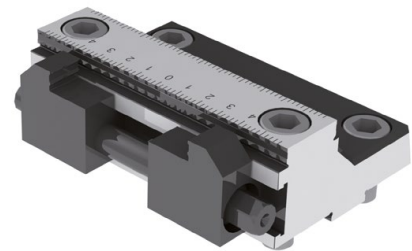
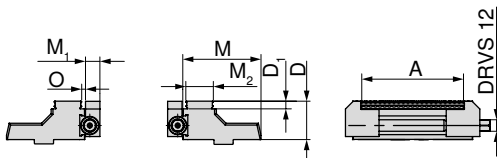



voor breedte	A	D	D <sub>1</sub>	M	M <sub>1</sub>	M <sub>2</sub>	O	WT	80 898 ...
mm	mm	mm	mm	mm	mm	mm	mm	kg	EUR
125	37 - 101	40	8	81,5	15	28,7	3,2	4,5	Y4
									1.760,00
									230

## Overzicht systeem-toeberehen

### Trekstangverlenging

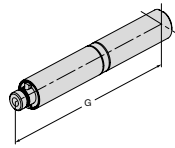
▲ incl. verdraai-beveiliging

H5G	H5G-S		
H5G-Z			

<b>80 898 ...</b>
EUR Y4
125 360,00 826
250 408,00 827

G mm
125
250

### Afdichtstop

▲ prijs per stuk

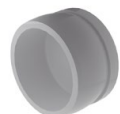
H5G-Z	

<b>80 907 ...</b>
EUR Y4
19 1,20 501

D <sub>1</sub> mm
19

### Basis voor verlenging

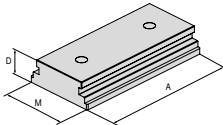
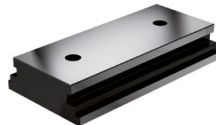
H5G		

<b>80 898 ...</b>
EUR Y4
250 644,00 725

A mm	D mm	M mm
250	45	125,5

### Spansleutel



▲ incl. toebehoren

NCG	NCG 5A	
H5G		

<b>80 890 ...</b>
EUR Y4
14 128,00 501

DRVS mm
14

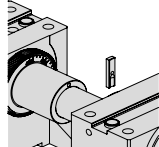
### Verdraai-beveiliging

H5G	H5G-S		
H5G-Z	H5G-Z-S		

<b>80 898 ...</b>
EUR Y4
12,40 024

### Knie spansleutel

▲ zonder dop

H5G-Z	H5G-Z-S	
ESG 4	ESG mini	
ZSG 4		

<b>80 891 ...</b>
EUR Y4
1/2" 76,10 600

vierkant
1/2"

### Handkruk

▲ voor snelverstelling

	H5G-Z	H5G-S	H5G
	X5G-Z	H5G-Z-S	

<b>80 907 ...</b>	<b>80 898 ...</b>	<b>80 898 ...</b>
EUR Y4	EUR Y4	EUR Y4
14 81,00 500	14 81,00 026	14 81,00 025

DRVS mm
14

### Inbusdop

▲ voor vierkant 1/2" of 3/8"

H5G-Z	ESG mini	
MSG 2	Verso	
MNG		

<b>80 877 ...</b>
EUR Y4
1/2" 18,20 214

vierkant	DRVS mm
1/2"	14

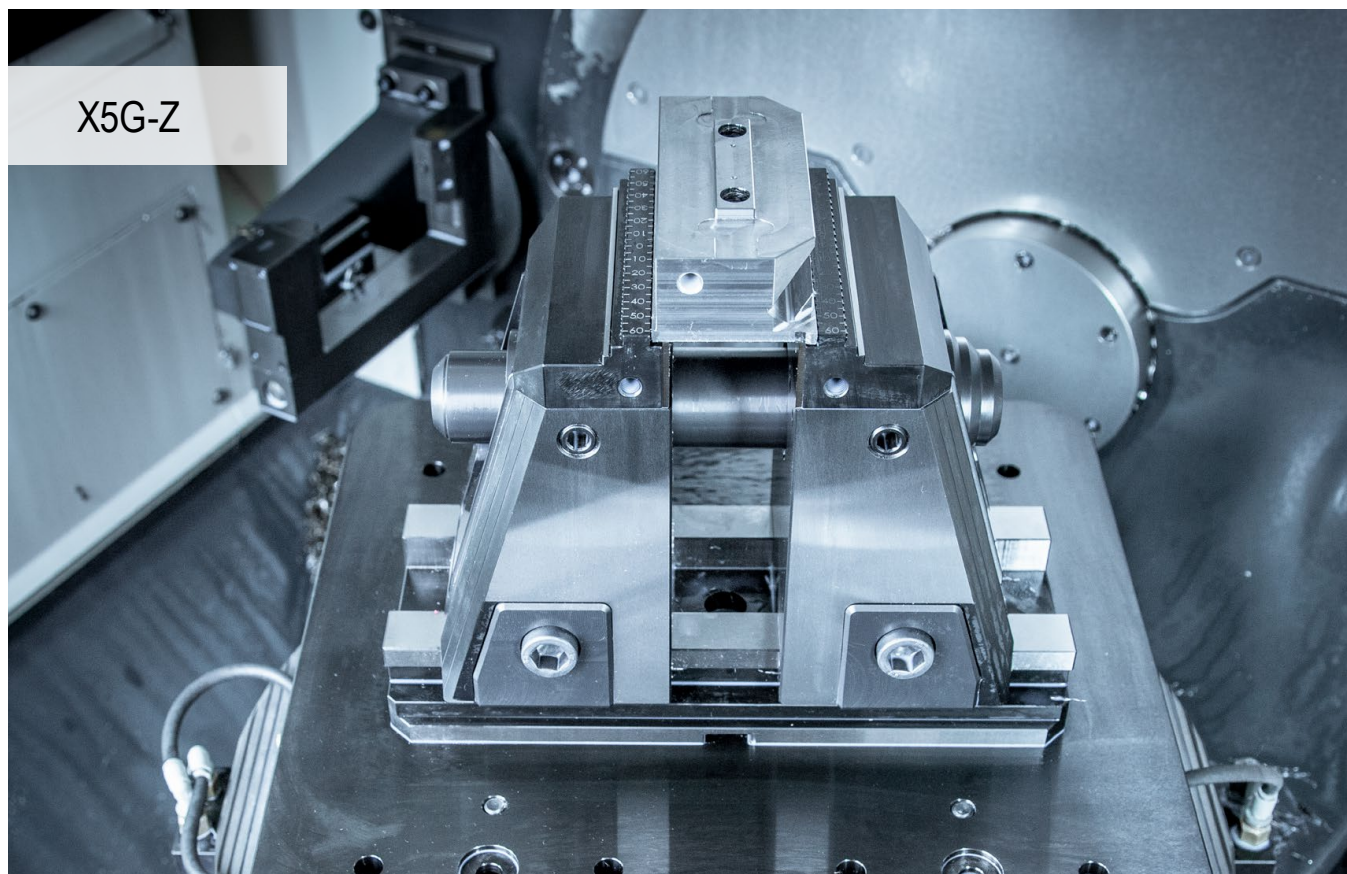

X5G-Z

## Volmaakte 5-as-bewerking

Eenvoudige handling en geïntegreerde neertrek functie voor 6-zijden bewerking. X5G-Z is de nieuwe 5-as spanner van CERATIZIT. Alle voordelen voor een optimale en eenvoudige 5- en 6-zijdenbewerking verenigd in één klem.

### Uw voordelen:

- ▲ naar keuze 5- en 6-zijden bewerking door het klemmen van een of beide bekken
- ▲ bekken snel verwisselbaar zonder gereedschap
- ▲ beste toegankelijkheid van alle zijden en grote spanweg van 130 mm
- ▲ volledig ingekapselde, mechanische spindel
- ▲ geïntegreerde, interne elastomeerdemping om trillingen te minimaliseren
- ▲ omvangrijk modulair bekkenprogramma



### Opspannen / uitlijnen:



Opspannen met twee pasbouten  $\text{\O} 12_{17}$  / M12 en spanbouten Artikel-nr. 80 895 019



Uitlijning door precisie pasblokken  $20^{H7}$  in de basis en in de T-gleuf van de machinetafel. Opspannen met klemvingers.



Uitlijnen en opspannen met nulpunt spansysteem MNG (2-3 opnamepennen). **Optioneel:** Positioneer- en bevestigingsgaten naar wens van de klant.

Spankracht:

grootte		max. aandraaimoment in Nm	max. spankracht in kN
X5G-Z	Ruw materiaal spannen	100	50
X5G-Z	Precisie spannen	120	40
X5G-Z-S	Ruw materiaal spannen	100	50
X5G-Z-S	Precisie spannen	120	34

Aantrekmoment / spankracht X5G-Z

Ruw materiaal spannen

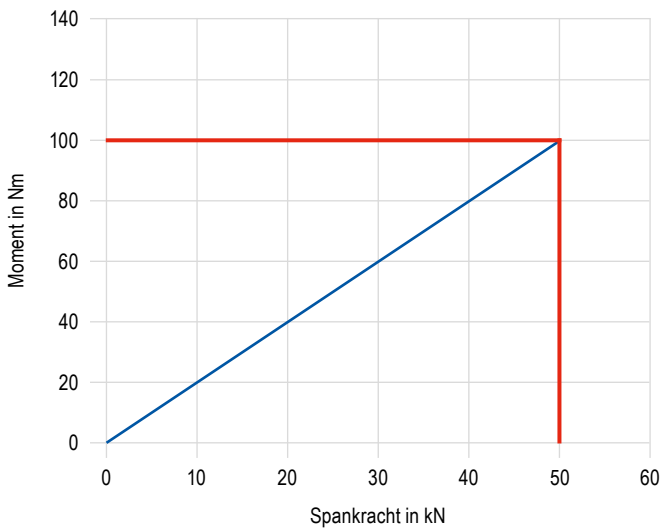

Precisie spannen

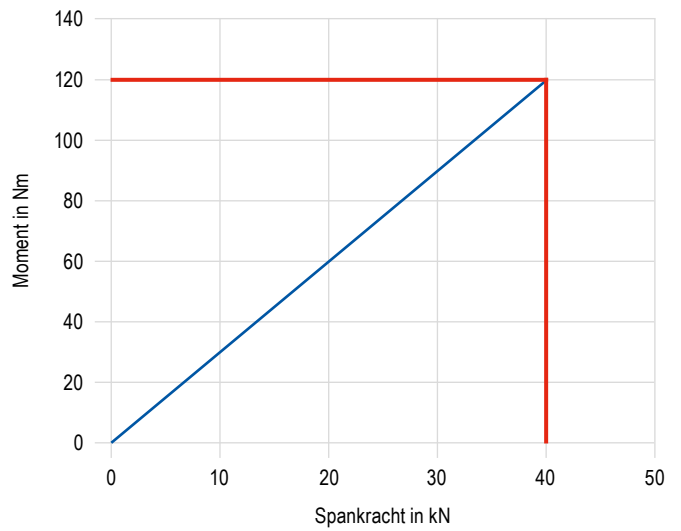

Aantrekmoment / spankracht X5G-Z-S

Ruw materiaal spannen

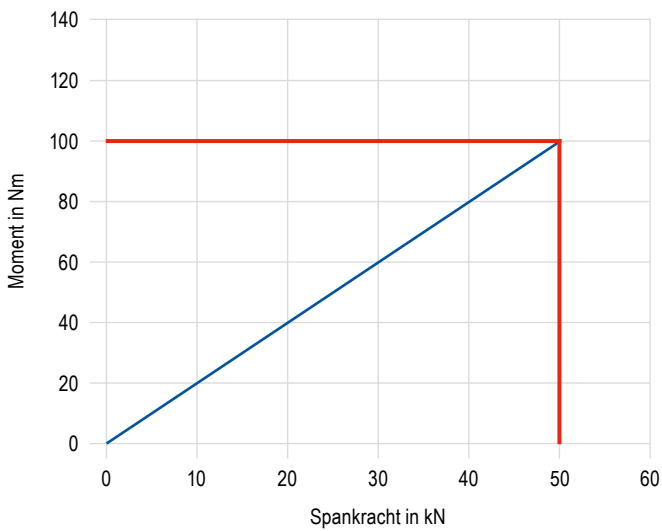

Precisie spannen

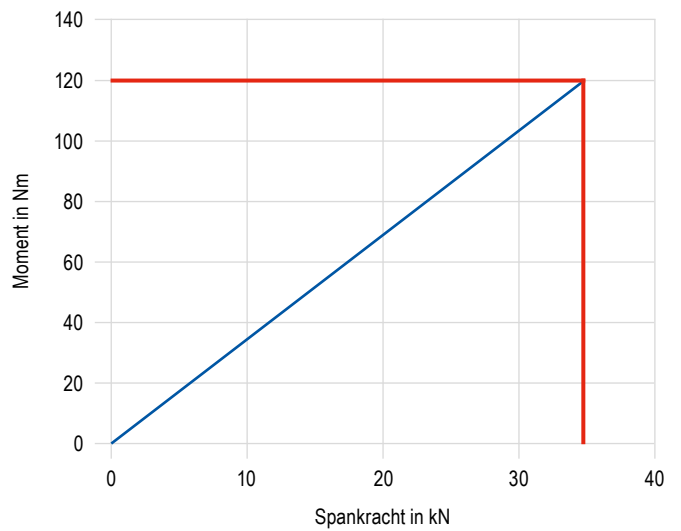

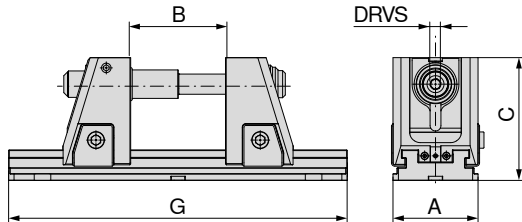
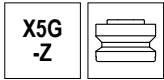

## SoloClamp – X5G-Z

- ▲ mechanische 5-asser machineklem met verplaatsbare vaste bek, hoogte 181 mm
- ▲ zonder systeembekken
- ▲ zeer toegankelijk
- ▲ 5- en 6-zijdenbewerking mogelijk
- ▲ Snelwissel bekken
- ▲ Opspannen op de machinetafel is mogelijk met MNG/PNG pennen of direct door de basis



A	B	C	G	DRVS	MXC	WT	<b>80 908 ...</b>	
mm	mm	mm	mm	mm	kN	kg	<b>EUR</b>	
125	4 - 134	181	330	14	40	33,2	<b>3.170,00</b>	<b>52500</b>
125	4 - 234	181	430	14	40	36,1	<b>3.400,00</b>	<b>52600</b>
125	4 - 304	181	500	14	40	38,1	<b>3.540,00</b>	<b>52700</b>
125	4 - 434	181	630	14	40	41,8	<b>3.800,00</b>	<b>52800</b>
125	4 - 604	181	800	14	40	46,6	<b>4.140,00</b>	<b>52900</b>

 Standaard slag 130 mm

 → **pagina 48**  
Hier vindt u de trekstangverlengingen, die moeten worden ingezet om de maximale spanbreedte te bereiken.

 → **pagina 42-44**  
Hier vindt u de maattabellen voor de verschillende bekken.

### Klemmengids

Maten van de onderzijde	<b>41</b>	Systeem-toebehoren	<b>45</b>
MNG-/PNG nulpuntspansysteem	<b>134-163</b>	Algemeen toebehoren	<b>164-183</b>

## SoloClamp – X5G-Z-S

- ▲ mechanische 5-asser machineklem met verplaatsbare vaste bek, hoogte 142 mm
- ▲ zonder systeembekken
- ▲ zeer toegankelijk
- ▲ 5- en 6-zijdenbewerking mogelijk
- ▲ Snelwissel bekken
- ▲ Opspannen op de machinetafel is mogelijk met MNG/PNG pennen of direct door de basis

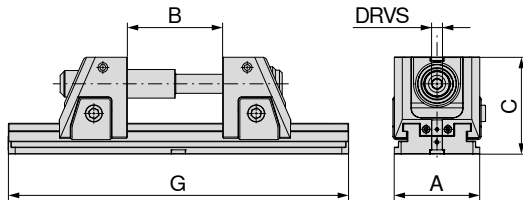
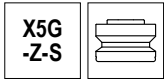

A	B	C	G	DRVS	MXC	WT	<b>80 908 ...</b>	
mm	mm	mm	mm	mm	kN	kg	<b>EUR</b>	
125	4 - 134	142	330	14	40	27,3	<b>Y4</b>	
125	4 - 234	142	430	14	40	30,2	2.880,00	<b>42500</b>
125	4 - 304	142	500	14	40	32,2	3.110,00	<b>42600</b>
125	4 - 434	142	630	14	40	35,9	3.250,00	<b>42700</b>
125	4 - 604	142	800	14	40	40,7	3.510,00	<b>42800</b>
							3.860,00	<b>42900</b>

 Standaard slag 130 mm

 → **pagina 48**  
Hier vindt u de trekstangverlengingen, die moeten worden ingezet om de maximale spanbreedte te bereiken.

 → **pagina 42-44**  
Hier vindt u de maattabellen voor de verschillende bekken.

### Klemmengids

Maten van de onderzijde	41	Systeem-toebehoren	45
MNG-/PNG nulpuntspansysteem	134-163	Algemeen toebehoren	164-183

## Maten van de onderzijde van X5G-Z/-S

Basisbreedte 125 mm en lengte 330 mm

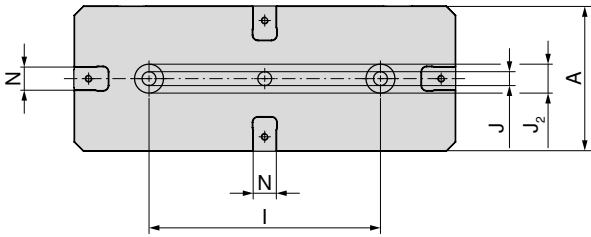

A	I <sub>±0,02</sub>	J <sub>H7</sub>	J <sub>2 H6</sub>	N <sub>H7</sub>
mm	mm	mm	mm	mm
125	200	12	25	20

Basisbreedte 125 mm en lengte 630 mm

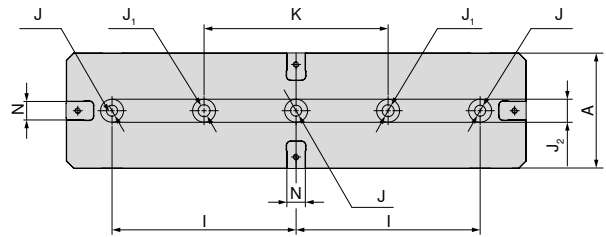

A	I <sub>±0,02</sub>	J <sub>H7</sub>	J <sub>1</sub>	J <sub>2 H6</sub>	K <sub>±0,02</sub>	N <sub>H7</sub>
mm	mm	mm	mm	mm	mm	mm
125	200	12	13	25	200	20

Basisbreedte 125 mm en lengte 430 mm

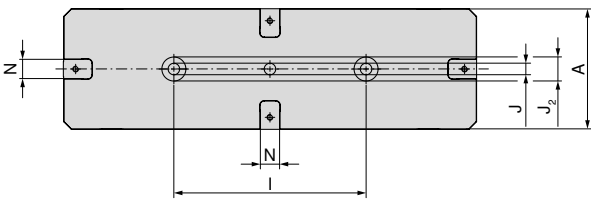

A	I <sub>±0,02</sub>	J <sub>H7</sub>	J <sub>2 H6</sub>	N <sub>H7</sub>
mm	mm	mm	mm	mm
125	200	12	25	20

Basisbreedte 125 mm en lengte 800 mm

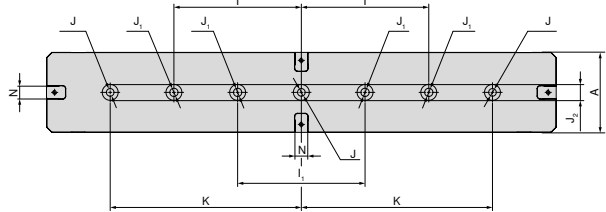

A	I <sub>±0,02</sub>	I <sub>1 ±0,02</sub>	J <sub>H7</sub>	J <sub>1</sub>	J <sub>2 H6</sub>	K <sub>±0,02</sub>	N <sub>H7</sub>
mm	mm	mm	mm	mm	mm	mm	mm
125	200	200	12	13	25	300	20

Basisbreedte 125 mm en lengte 500 mm

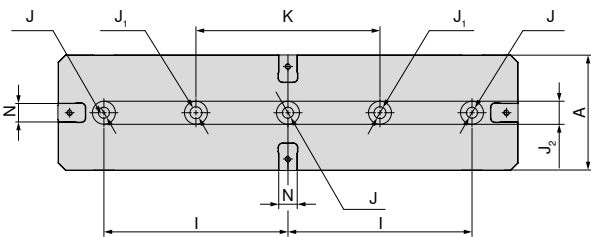

A	I <sub>±0,02</sub>	J <sub>H7</sub>	J <sub>1</sub>	J <sub>2 H6</sub>
mm	mm	mm	mm	mm
125	200	12	13	25



## X5G-Z/-S maattabellen voor de verschillende bekken

met gripbekken 3 mm

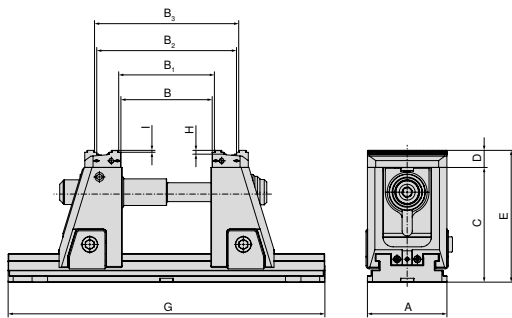

type	Spindelverlenging 430 mm 80 908 80000	Spindelverlenging 500 mm 80 908 80100	Spindelverlenging 630 mm 80 908 80200	Spindelverlenging 800 mm 80 908 80300	A	B	B <sub>1</sub>	B <sub>2</sub>	B <sub>3</sub>	C	D	E	G	H	I
80 908 52500					125	5-134	12-141	80-210	88-217	181	27	208	330	6	3
80 908 42500					125	5-134	12-141	80-210	88-217	142	27	169	330	6	3
80 908 52600	1 x				125	5-234	12-241	80-310	88-317	181	27	208	430	6	3
80 908 42600	1 x				125	5-234	12-241	80-310	88-317	142	27	169	430	6	3
80 908 52700	1 x	1 x			125	5-304	12-311	80-380	88-387	181	27	208	500	6	3
80 908 42700	1 x	1 x			125	5-304	12-311	80-380	88-387	142	27	169	500	6	3
80 908 52800	1 x	1 x	1 x		125	5-434	12-441	80-510	88-517	181	27	208	630	6	3
80 908 42800	1 x	1 x	1 x		125	5-434	12-441	80-510	88-517	142	27	169	630	6	3
80 908 52900	1 x	1 x	1 x	1 x	125	5-604	12-611	80-680	88-687	181	27	208	800	6	3
80 908 42900	1 x	1 x	1 x	1 x	125	5-604	12-611	80-680	88-687	142	27	169	800	6	3

met gripbekken 5 mm

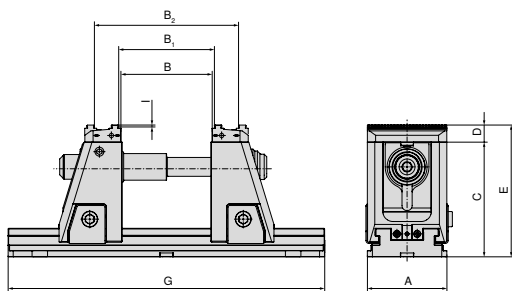

type	Spindelverlenging 430 mm 80 908 80000	Spindelverlenging 500 mm 80 908 80100	Spindelverlenging 630 mm 80 908 80200	Spindelverlenging 800 mm 80 908 80300	A	B	B <sub>1</sub>	B <sub>2</sub>	C	D	E	G	I
80 908 52500					125	5-134	12-141	88-217	181	27	208	330	5
80 908 42500					125	5-134	12-141	88-217	142	27	169	330	5
80 908 52600	1 x				125	5-234	12-241	88-317	181	27	208	430	5
80 908 42600	1 x				125	5-234	12-241	88-317	142	27	169	430	5
80 908 52700	1 x	1 x			125	5-304	12-311	88-387	181	27	208	500	5
80 908 42700	1 x	1 x			125	5-304	12-311	88-387	142	27	169	500	5
80 908 52800	1 x	1 x	1 x		125	5-434	12-441	88-517	181	27	208	630	5
80 908 42800	1 x	1 x	1 x		125	5-434	12-441	88-517	142	27	169	630	5
80 908 52900	1 x	1 x	1 x	1 x	125	5-604	12-611	88-687	181	27	208	800	5
80 908 42900	1 x	1 x	1 x	1 x	125	5-604	12-611	88-687	142	27	169	800	5



→ pagina 48

Hier vindt u de geschikte trekstangverlengingen.

## X5G-Z/-S maattabellen voor de verschillende bekken

met getrapte carbide 5 mm gripbekken

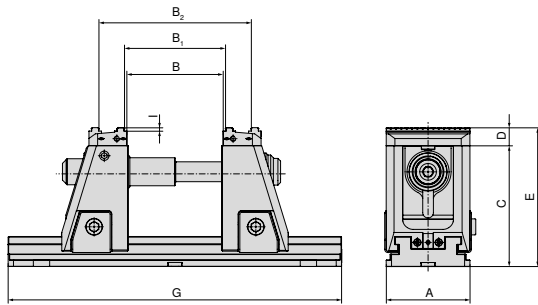

type	Spindelverlenging 430 mm 80 908 80000	Spindelverlenging 500 mm 80 908 80100	Spindelverlenging 630 mm 80 908 80200	Spindelverlenging 800 mm 80 908 80300	A	B	B <sub>1</sub>	B <sub>2</sub>	C	D	E	G	I
80 908 52500					125	5-134	12-141	88-217	181	27	208	330	5
80 908 42500					125	5-134	12-141	88-217	142	27	169	330	5
80 908 52600	1 x				125	5-234	12-241	88-317	181	27	208	430	5
80 908 42600	1 x				125	5-234	12-241	88-317	142	27	169	430	5
80 908 52700	1 x	1 x			125	5-304	12-311	88-387	181	27	208	500	5
80 908 42700	1 x	1 x			125	5-304	12-311	88-387	142	27	169	500	5
80 908 52800	1 x	1 x	1 x		125	5-434	12-441	88-517	181	27	208	630	5
80 908 42800	1 x	1 x	1 x		125	5-434	12-441	88-517	142	27	169	630	5
80 908 52900	1 x	1 x	1 x	1 x	125	5-604	12-611	88-687	181	27	208	800	5
80 908 42900	1 x	1 x	1 x	1 x	125	5-604	12-611	88-687	142	27	169	800	5

met zachte bekken, staal

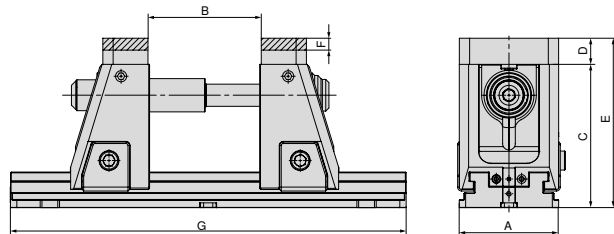
Artikel-nr.  
Systeembekken

2 x 80 909 31200

type	Spindelverlenging 430 mm 80 908 80000	Spindelverlenging 500 mm 80 908 80100	Spindelverlenging 630 mm 80 908 80200	Spindelverlenging 800 mm 80 908 80300	A	B	C	D	E	F	G
80 908 52500					125	4-134	181	33	214	15	330
80 908 42500					125	4-134	142	33	175	15	330
80 908 52600	1 x				125	4-234	181	33	214	15	430
80 908 42600	1 x				125	4-234	142	33	175	15	430
80 908 52700	1 x	1 x			125	4-304	181	33	214	15	500
80 908 42700	1 x	1 x			125	4-304	142	33	175	15	500
80 908 52800	1 x	1 x	1 x		125	4-434	181	33	214	15	630
80 908 42800	1 x	1 x	1 x		125	4-434	142	33	175	15	630
80 908 52900	1 x	1 x	1 x	1 x	125	4-604	181	33	214	15	800
80 908 42900	1 x	1 x	1 x	1 x	125	4-604	142	33	175	15	800



→ pagina 48

Hier vindt u de geschikte trekstangverlengingen.

# X5G-Z/-S maattabellen voor de verschillende bekken

met Prägeprofil bekken

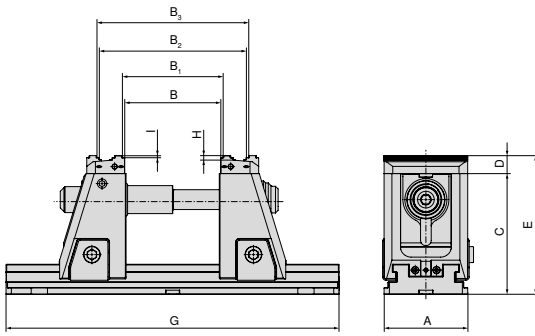

Artikel-nr.  
Systeembekken  
2 x **80 908 31200**

type	Spindelverlenging 430 mm 80 908 80000	Spindelverlenging 500 mm 80 908 80100	Spindelverlenging 630 mm 80 908 80200	Spindelverlenging 800 mm 80 908 80300	A	B	B <sub>1</sub>	B <sub>2</sub>	B <sub>3</sub>	C	D	E	G	H	I
80 908 52500					125	5-134	12-141	82-210	89-217	181	27	208	330	6	3
80 908 42500					125	5-134	12-141	82-210	89-217	142	27	169	330	6	3
80 908 52600	1 x				125	5-234	12-241	82-310	89-317	181	27	208	430	6	3
80 908 42600	1 x				125	5-234	12-241	82-310	89-317	142	27	169	430	6	3
80 908 52700	1 x	1 x			125	5-304	12-311	82-380	89-387	181	27	208	500	6	3
80 908 42700	1 x	1 x			125	5-304	12-311	82-380	89-387	142	27	169	500	6	3
80 908 52800	1 x	1 x	1 x		125	5-434	12-441	82-510	89-517	181	27	208	630	6	3
80 908 42800	1 x	1 x	1 x		125	5-434	12-441	82-510	89-517	142	27	169	630	6	3
80 908 52900	1 x	1 x	1 x	1 x	125	5-604	12-611	82-680	89-687	181	27	208	800	6	3
80 908 42900	1 x	1 x	1 x	1 x	125	5-604	12-611	82-680	89-687	142	27	169	800	6	3

met pendelbekken en adapterplaten

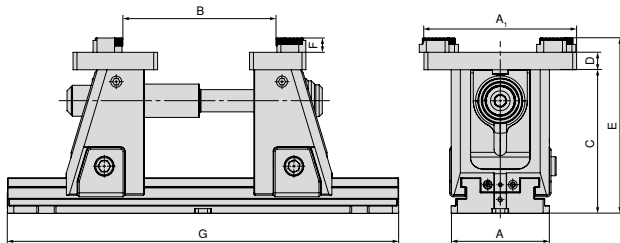

Artikel-nr.  
Systeembekken  
**80 909 31500 + 80 909 31300**

type	Spindelverlenging 430 mm 80 908 80000	Spindelverlenging 500 mm 80 908 80100	Spindelverlenging 630 mm 80 908 80200	Spindelverlenging 800 mm 80 908 80300	A	B	C	D	E	F	G
80 908 52500					125	42-210	181	22	221	18	330
80 908 42500					125	42-210	142	22	182	18	330
80 908 52600	1 x				125	42-310	181	22	221	18	430
80 908 42600	1 x				125	42-310	142	22	182	18	430
80 908 52700	1 x	1 x			125	42-380	181	22	221	18	500
80 908 42700	1 x	1 x			125	42-380	142	22	182	18	500
80 908 52800	1 x	1 x	1 x		125	42-510	181	22	221	18	630
80 908 42800	1 x	1 x	1 x		125	42-510	142	22	182	18	630
80 908 52900	1 x	1 x	1 x	1 x	125	42-680	181	22	221	18	800
80 908 42900	1 x	1 x	1 x	1 x	125	42-680	142	22	182	18	800



→ pagina 48  
Hier vindt u de geschikte trekstangverlengingen.

## Overzicht systeembekken

### Gripbek 3 mm

▲ prijs per stuk

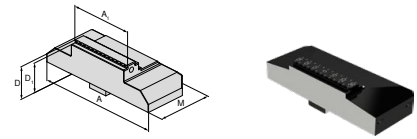

voor basisbreedte	A	A <sub>1</sub>	D	D <sub>1</sub>	D <sub>2</sub>	E	M	M <sub>1</sub>	M <sub>2</sub>	EUR	Y4	NCG	H5G / -S / -Z	X5G-Z / -S	ESG 4	ESG 5	HDG 2	ZSG 4	ZSG mini	DSG 4	Versto	HSG		
125	125	40	27	24			57			302,00	80 908 30300			●										
125	125	65	27	24			57			314,00	80 908 30200			●										
125	125	80	27	24			57			314,00	80 908 30100			●										
125	125	125	27	24			57			324,00	80 908 30000			●										

### Gripbek 5 mm

▲ prijs per stuk

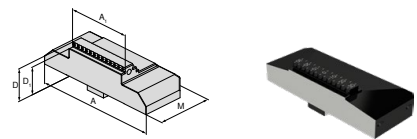

voor basisbreedte	A	A <sub>1</sub>	D	D <sub>1</sub>	D <sub>2</sub>	E	M	M <sub>1</sub>	M <sub>2</sub>	EUR	Y4	NCG	H5G / -S / -Z	X5G-Z / -S	ESG 4	ESG 5	HDG 2	ZSG 4	ZSG mini	DSG 4	Versto	HSG		
125	125	40	27	22			57			302,00	80 908 30700			●										
125	125	65	27	22			57			314,00	80 908 30600			●										
125	125	80	27	22			57			314,00	80 908 30500			●										
125	125	125	27	22			57			324,00	80 908 30400			●										

### Gladde bek

▲ prijs per stuk

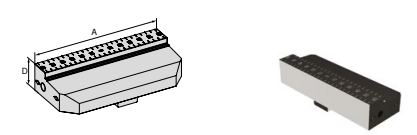

voor basisbreedte	A	A <sub>1</sub>	D	D <sub>1</sub>	D <sub>2</sub>	E	M	M <sub>1</sub>	M <sub>2</sub>	EUR	Y4	NCG	H5G / -S / -Z	X5G-Z / -S	ESG 4	ESG 5	HDG 2	ZSG 4	ZSG mini	DSG 4	Versto	HSG		
125	125		27							324,00	80 908 31400			●										

### Getrapte carbide gripbek, 5 mm

▲ prijs per stuk

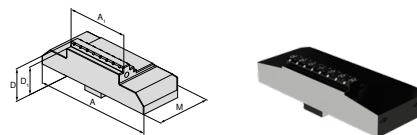

voor basisbreedte	A	A <sub>1</sub>	D	D <sub>1</sub>	D <sub>2</sub>	E	M	M <sub>1</sub>	M <sub>2</sub>	EUR	Y4	NCG	H5G / -S / -Z	X5G-Z / -S	ESG 4	ESG 5	HDG 2	ZSG 4	ZSG mini	DSG 4	Versto	HSG		
125	125	40	27	22			57			358,00	80 908 31100			●										
125	125	65	27	22			57			370,00	80 908 31000			●										
125	125	80	27	22			57			380,00	80 908 30900			●										
125	125	125	27	22			57			392,00	80 908 30800			●										

## Overzicht systeembekken

### Zachte bek (staal)

- ▲ materiaal: 16MnCr5
- ▲ prijs per stuk

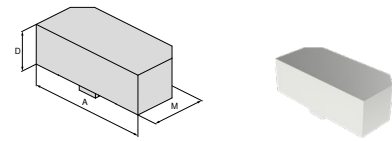

voor basisbreedte	A	A <sub>1</sub>	D	D <sub>1</sub>	D <sub>2</sub>	E	M	M <sub>1</sub>	M <sub>2</sub>	EUR	Y4	NCG	H5G / -S / -Z	X5G-Z / -S	ESG 4	ESG 5	HDG 2	ZSG 4	ZSG mini	DSG 4	Verzo	HSG	
125	125		33				57			140,00				●									

### Prägeprofil bek

- ▲ prijs per stuk
- ▲ passend op LANG Prägeprofil

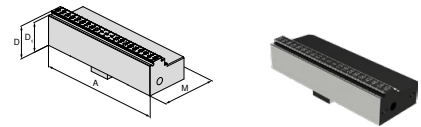

voor basisbreedte	A	A <sub>1</sub>	D	D <sub>1</sub>	D <sub>2</sub>	E	M	M <sub>1</sub>	M <sub>2</sub>	EUR	Y4	NCG	H5G / -S / -Z	X5G-Z / -S	ESG 4	ESG 5	HDG 2	ZSG 4	ZSG mini	DSG 4	Verzo	HSG	
125	125		27	24			57			324,00				●									

### Adapterplaat

- ▲ voor opname van 6-voudige bekken
- ▲ prijs per stuk
- ▲ incl. afdekschroeven

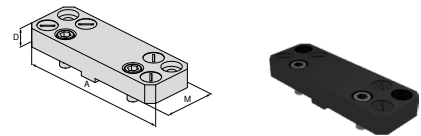

voor basisbreedte	A	A <sub>1</sub>	D	D <sub>1</sub>	D <sub>2</sub>	E	M	M <sub>1</sub>	M <sub>2</sub>	EUR	Y4	NCG	H5G / -S / -Z	X5G-Z / -S	ESG 4	ESG 5	HDG 2	ZSG 4	ZSG mini	DSG 4	Verzo	HSG	
125	180		22				104			414,00				●									

### Pendelbek

- ▲ voor opname van 6-voudige bekken
- ▲ prijs per stuk
- ▲ incl. afdekschroeven

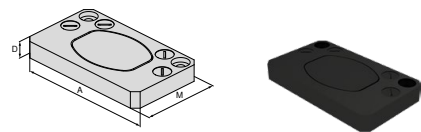

voor basisbreedte	A	A <sub>1</sub>	D	D <sub>1</sub>	D <sub>2</sub>	E	M	M <sub>1</sub>	M <sub>2</sub>	EUR	Y4	NCG	H5G / -S / -Z	X5G-Z / -S	ESG 4	ESG 5	HDG 2	ZSG 4	ZSG mini	DSG 4	Verzo	HSG	
125	180		22				62			553,00				●									

# Overzicht systeembekken

## 6-voudige bek

- ▲ 1 = glad, wolframcarbide gecoat
- ▲ 2 = grip met trap 3 mm
- ▲ 3 = grip met trap 8 mm
- ▲ 4 = grip met trap 18 mm
- ▲ 5 = grip met trap 8 mm
- ▲ 6 = grip rond
- ▲  $M_{max} = 60 \text{ Nm}$
- ▲ incl. bevestigingsbout

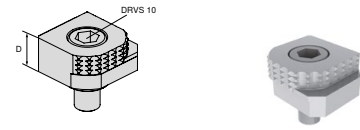

voor basisbreedte	A	A <sub>1</sub>	D	D <sub>1</sub>	D <sub>2</sub>	E	M	M <sub>1</sub>	M <sub>2</sub>	EUR	Y4	NCG	H5G / -S / -Z	X5G-Z / -S	ESG 4	ESG 5	HDC 2	ZSG 4	ZSG mini	DSG 4	Veriso	HSG	
			18							80,60	80 892 246	●	●	●	●				●	●	●	●	

## 6-voudige bek

- ▲ 1 = glad
- ▲ 2 = carbide grip
- ▲ 3 = carbide grip met trap 3 mm
- ▲ 4 = carbide grip met trap 8 mm
- ▲ 5 = carbide grip rond met trap 8 mm
- ▲ 6 = carbide grip rond
- ▲ incl. bevestigingsbout

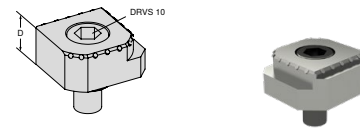

voor basisbreedte	A	A <sub>1</sub>	D	D <sub>1</sub>	D <sub>2</sub>	E	M	M <sub>1</sub>	M <sub>2</sub>	EUR	Y4	NCG	H5G / -S / -Z	X5G-Z / -S	ESG 4	ESG 5	HDC 2	ZSG 4	ZSG mini	DSG 4	Veriso	HSG	
			18							117,00	80 890 35300	●	●	●	●				●	●	●	●	

## Precisiebekken

- ▲ prijs per set

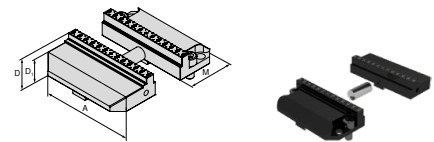

voor basisbreedte	A	A <sub>1</sub>	D	D <sub>1</sub>	D <sub>2</sub>	E	M	M <sub>1</sub>	M <sub>2</sub>	EUR	Y4	NCG	H5G / -S / -Z	X5G-Z / -S	ESG 4	ESG 5	HDC 2	ZSG 4	ZSG mini	DSG 4	Veriso	HSG	
125	125		27	24			57			490,00	80 908 31300			●									

### Procedure voor de geharde precisiebekken-set

De X5G-Z overtuigt door een zeer hoge precisie, alle componenten zijn met hoge precisie geslepen en gehard. Toch zijn er toepassingen waarbij de gewenste tolerantie van snelwisselbekken niet voldoet aan de eisen van het werkstuk. Voor deze gevallen bieden wij een geharde precisiebekken-set aan (art.nr. 80 908 31300), die door de klant op het spanvlak (aan beide zijden) kan worden nabewerkt voor de allerhoogste precisie.

De hardfrees bewerking wordt uitgevoerd in gespannen toestand (beide schroeven op de verstelbare vaste bekken zijn aangedraaid met 140 Nm). De precisiebekken moeten: volgens aanzicht 1+2, worden gefreesd (hardfreesen). Het meegeleverde referentie-blok wordt gebruikt voor het klemmen in de standaard positie (1). Bij het spannen in omgedraaide positie (2) kan een eindmaat worden gebruikt.

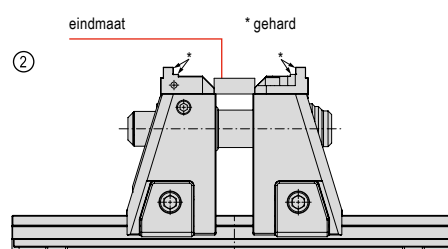
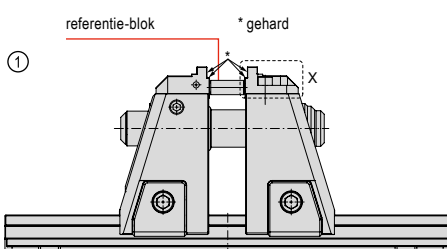

## Overzicht systeem-toebehoren

### Spindeleenheid X5G-Z

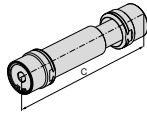

C mm	WT kg
227,5	2,5

**80 908 ...**  
EUR  
Y4  
392,00 50100

### Handkruk

- ▲ uitvoering met zeskantpen
- ▲ voor snelverstelling



H5G-Z  
X5G-Z  
**80 907 ...**

voor breedte mm	DRVS mm
125	14

EUR  
Y4  
81,00 500

### Spindelverlenging

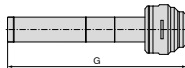

voor breedte mm	G mm
125	430
125	500
125	630
125	800

**80 908 ...**  
EUR  
Y4  
164,00 80000  
177,00 80100  
205,00 80200  
235,00 80300

### Inbusdop



vierkant	DRVS mm
1/2"	14

**80 877 ...**  
EUR  
Y4  
18,20 214

### Momentsleutel

- ▲ zonder inbusdop



vierkant	TQX Nm
1/2"	10 - 100

**80 884 ...**  
EUR  
Y4  
280,00 502

ESG 4

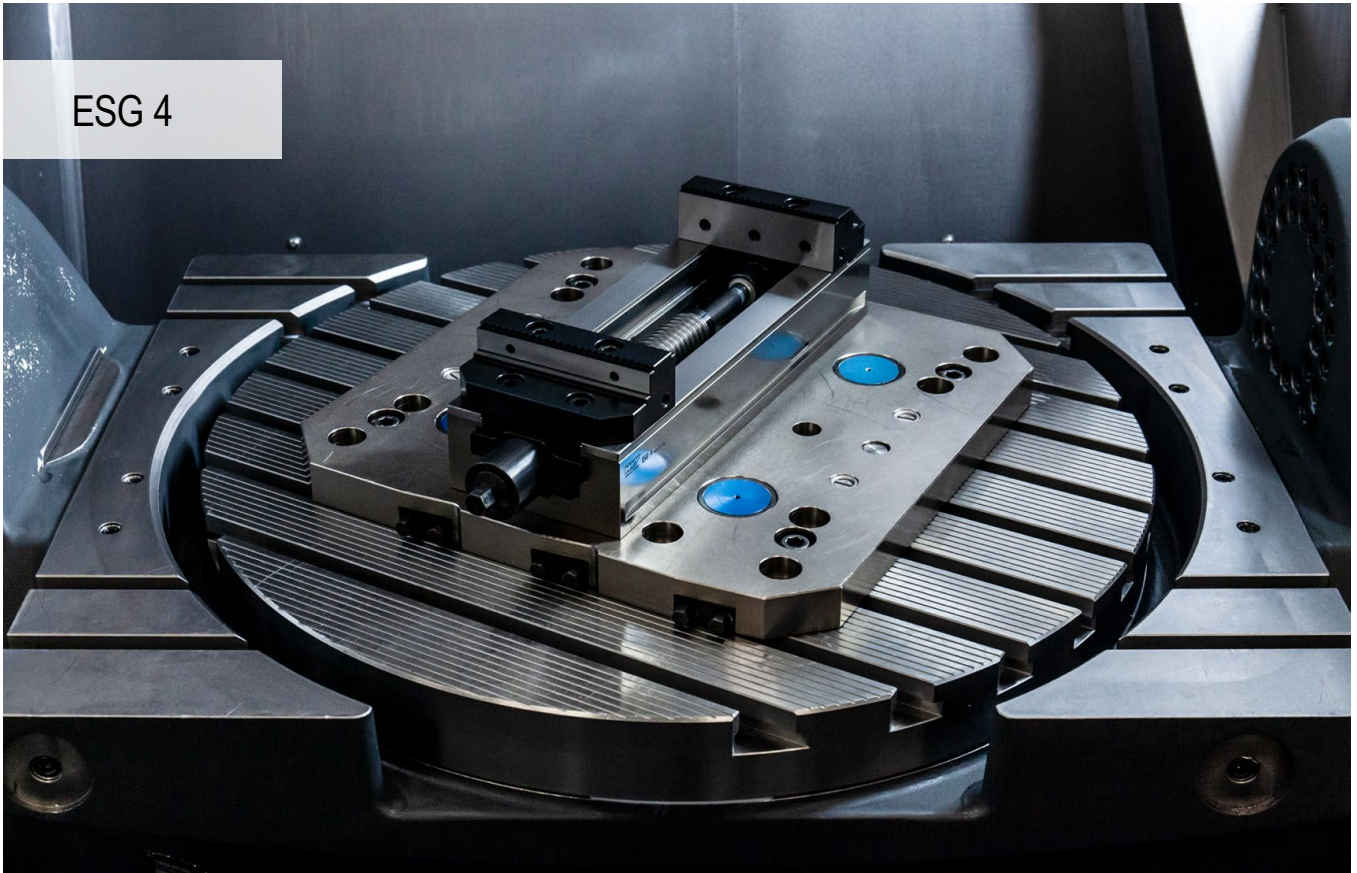

## Zeer efficiënte allrounder voor het bewerken van onbewerkte en bewerkte onderdelen

De ESG 4 enkelspanners overtuigen met hendel-snelspanning, snel instellen van het spanbereik, lage bouw en gering gewicht.

### Uw voordelen:

- ▲ meerdere koelmiddel afvoeren voor storingsvrij functioneren gecontroleerde afvoer
- ▲ eenvoudige en snelle positionering op het MNG-nulpunt-spansysteem
- ▲ hoge spankrachten tussen 5 – 50 kN met gering aantrekmoment
- ▲ eenvoudiger en sneller wisselen van bekken met 2 bouten
- ▲ snelle en eenvoudige demontage van de spindeleenheid
- ▲ omvangrijk modulair bekkenprogramma

### Opspannen / uitlijnen:



ESG 4 – 80 mm = bevestiging met M8-bouten door de basis  
ESG 4 – 125 mm / 160 mm = bevestiging met M12-bouten en pasbouten door de basis



Bevestiging met 4 klemvingers Artikel-nr. 80 890 315



Bevestiging met nulpunt-spansysteem  
ESG 4 – 80 mm = 1 opnamepen + verdraai-beveiliging  
ESG 4 – 125 / 160 mm = 2 opnamepennen steek 200 mm



## Spankracht:

## Aantrekmoment / spankracht ESG 4 – 80 mm

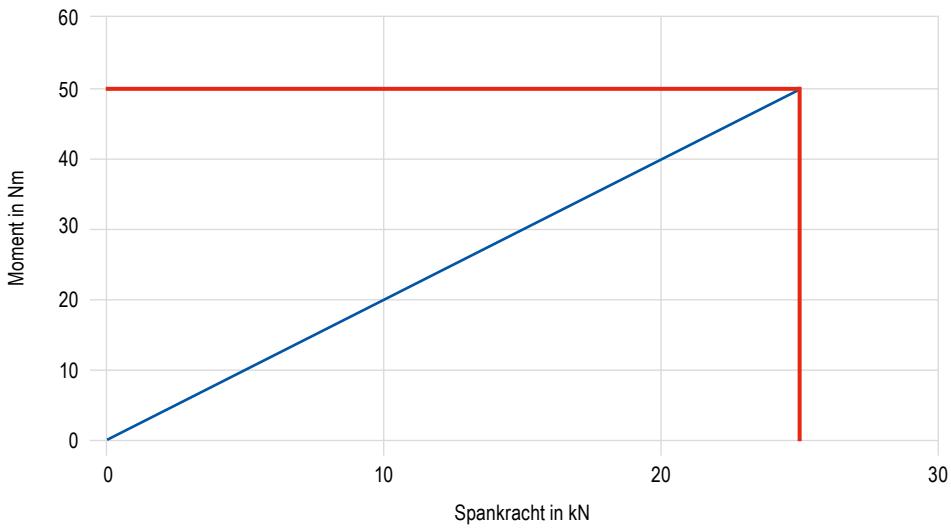

## Aantrekmoment / spankracht ESG 4 – 125 mm

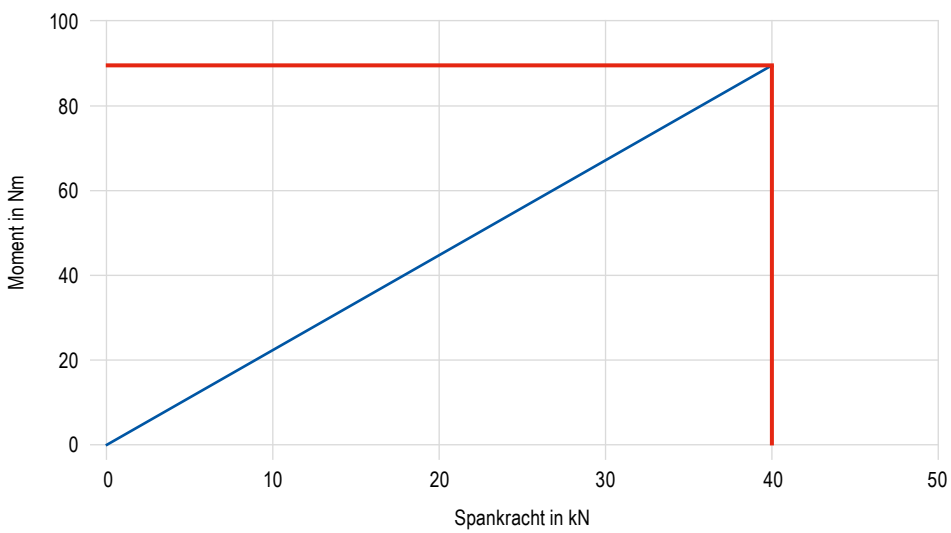

## Aantrekmoment / spankracht ESG 4 – 160 mm

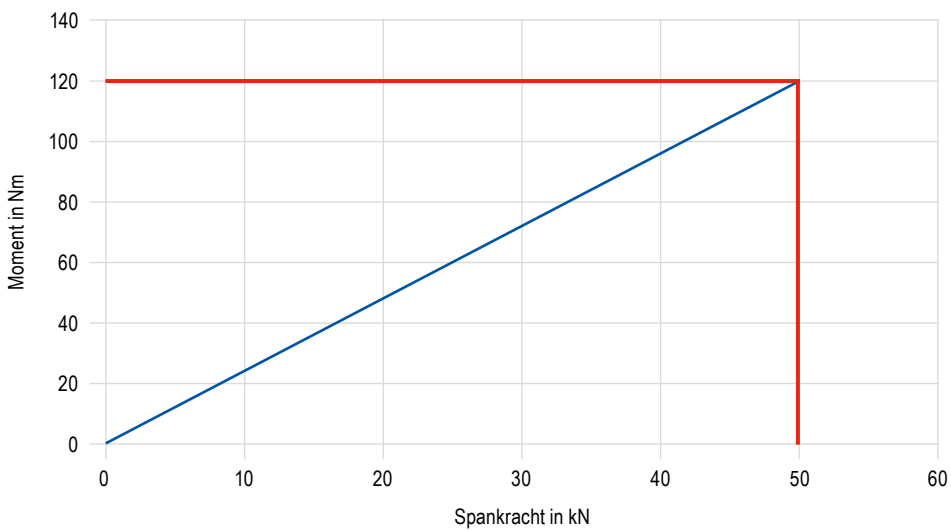

## SoloClamp – ESG 4

- ▲ enkelspanner zonder systeembekken
- ▲ snelle 160° hendelklemming met momentsleutel
- ▲ snelle in- en uitbouw van de spindelgroep
- ▲  $\pm 0,01$  mm repeeteernauwkeurigheid ( $\pm 0,015$  mm bij A = 160 mm)

ESG  
4

MNG

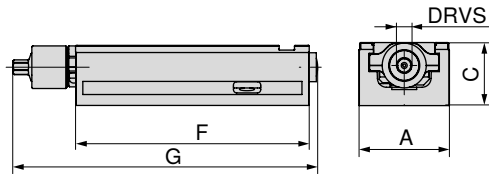

A	C <sub>-0.02</sub>	F	G	DRVS	MXC	WT	spanbereik	80 901 ...
mm	mm	mm	mm	mm	kN	kg	mm	EUR
80	55	214	284	12	25	5,0	0-192	Y4 1.230,00 080
125	60	362	433	14	40	15,0	0-308	1.520,00 125
160	70	480	559	14	50	28,5	0-434	2.220,00 160

### Klemmengids

Maten van de onderzijde	52	Maattabellen voor de verschillende bekken	53+54
Systeem-toebehoren	55-58	MNG-/PNG nulpuntspansysteem	134-163
Algemeen toebehoren	164-183		

## Maten van de onderzijde van ESG 4

Basisbreedte 80 mm en lengte 214 mm

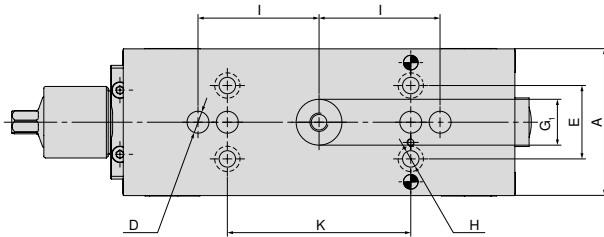

A	D	E	G <sub>1</sub>	H	I	K
mm	mm	mm	mm	mm	mm	mm
80	12	40	25	9	66	100

Basisbreedte 125 mm en lengte 362 mm

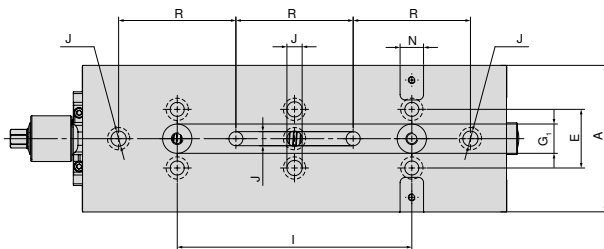

A	E	G <sub>1</sub>	I	J	N <sub>H7</sub>	R
mm	mm	mm	mm	mm	mm	mm
125	50	25	200	13	20	100

Basisbreedte 160 mm en lengte 480 mm

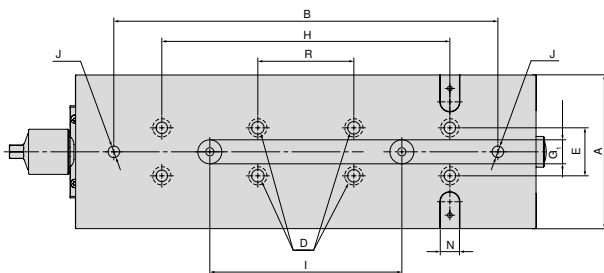

A	B	D	E	G <sub>1</sub>	H	I	J	N <sub>H7</sub>	R
mm	mm	mm	mm	mm	mm	mm	mm	mm	mm
160	400	13	50	25	300	200	12	20	100

# ESG 4 maattabellen voor de verschillende bekken

met blokbekken

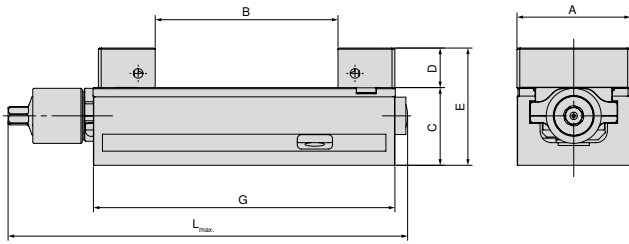

A mm	B mm	C mm	D mm	E mm	G mm	L <sub>max.</sub> mm	Artikel-nr. Systeembekken		
80	0 - 130	55	28	83	214	308	80 901 31200	+	80 901 31300
125	0 - 231	60	40	100	362	432	80 901 31400	+	80 901 31500
160	0 - 312	70	50	120	480	559	80 901 31600	+	80 901 31700

met zachte aluminium bekken

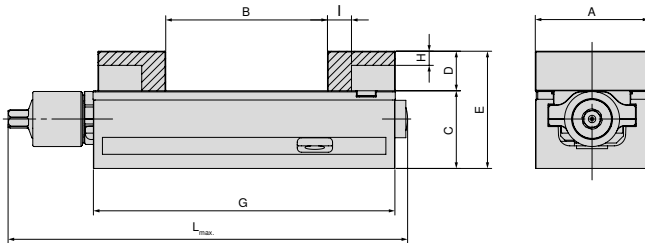

A mm	B mm	C mm	D mm	E mm	G mm	H mm	I mm	L <sub>max.</sub> mm	Artikel-nr. Systeembekken	
80	0 - 115	55	28	83	214	10	17	284	80 901 307	+ 80 878 850
125	0 - 219	60	40	100	362	23	27	432	80 901 304	+ 80 878 550
160	0 - 309	70	50	120	480	23	30	559	80 901 301	+ 80 878 305

met pendelbekken en adapterplaten

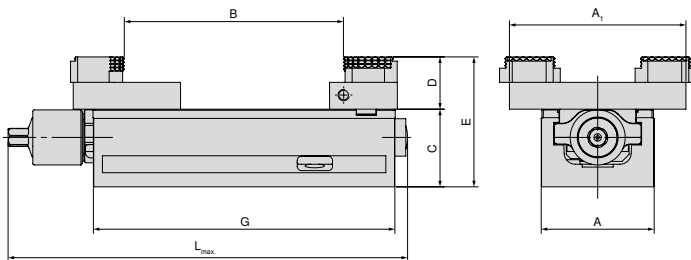

A mm	A <sub>1</sub> mm	B mm	C mm	D mm	E mm	G mm	L <sub>max.</sub> mm	Artikel-nr. Systeembekken		
80	125	5 - 155	55	19	92	214	284	80 878 870	+	80 901 501
125	180	4 - 306	60	22	100	362	432	80 878 570	+	80 901 502
160	256	11 - 463	70	22	110	480	559	80 878 670	+	80 901 503

# ESG 4 maattabellen voor de verschillende bekken

met gripbekken 3 mm

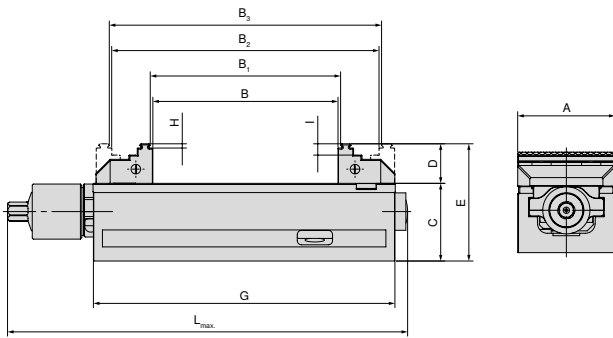

A mm	B mm	B <sub>1</sub> mm	B <sub>2</sub> mm	B <sub>3</sub> mm	C mm	D mm	E mm	G mm	H mm	I mm	L <sub>max</sub> mm	Artikel-nr. Systeembekken	
80	0 - 130	4 - 134	59 - 188	63 - 192	55	28	83	214	3	8	284	80 901 306	+ 80 878 810
125	0 - 231	8 - 238	71 - 301	78 - 308	60	40	100	362	3	18	433	80 901 302	+ 80 901 303
160	0 - 310	8 - 317	117 - 427	125 - 434	70	50	120	480	3	10	559	80 901 300	+ 80 878 610

Gripbek 3 mm, breedte 40 mm

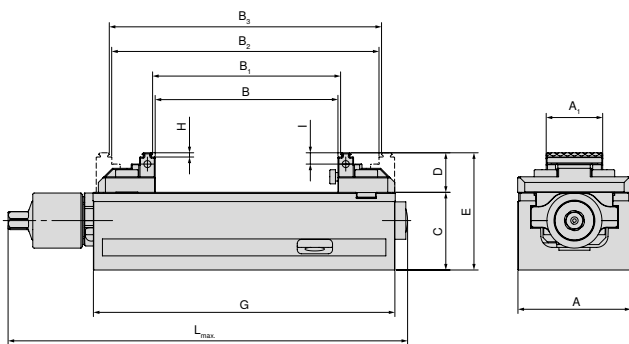

A mm	A <sub>1</sub> mm	B mm	B <sub>1</sub> mm	B <sub>2</sub> mm	B <sub>3</sub> mm	C mm	D mm	E mm	G mm	H mm	I mm	L <sub>max</sub> mm	Artikel-nr. Systeembekken	
80	40	0 - 130	4 - 134	59 - 188	63 - 192	55	28	83	214	3	8	284	80 901 308	+ 80 878 81900

met gripbekken 3 mm, breedte 65 mm

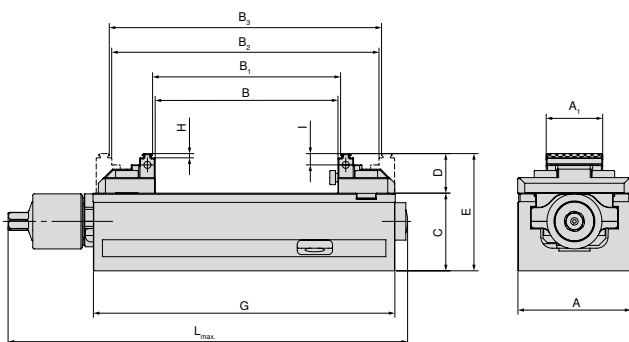

A mm	A <sub>1</sub> mm	B mm	B <sub>1</sub> mm	B <sub>2</sub> mm	B <sub>3</sub> mm	C mm	D mm	E mm	G mm	H mm	I mm	L <sub>max</sub> mm	Artikel-nr. Systeembekken	
125	65	0 - 240	8 - 247	77 - 317	84 - 324	60	33	93	362	3	9	432	80 901 305	+ 80 878 51900

## Overzicht systeembekken

### Gripbek 3 mm, vast

▲ prijs per stuk

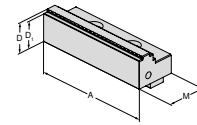

voor basisbreedte	A	A <sub>1</sub>	D	D <sub>1</sub>	D <sub>2</sub>	E	M	M <sub>1</sub>	M <sub>2</sub>	EUR	Y4	NCG	H5G / -S / -Z	X5G-Z / -S	ESG 4	ESG 5	HDG 2	ZSG 4	ZSG mini	DSG 4	Verso	HSG	
80	80		28	25			40			163,00	80 901 306				●	●							
125	125		40	37			66			224,00	80 901 302				●	●					●		
160	160		50	47			81			404,00	80 901 300				●	●							

### Gripbek 3 mm, los

▲ prijs per stuk

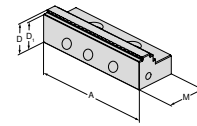

voor basisbreedte	A	A <sub>1</sub>	D	D <sub>1</sub>	D <sub>2</sub>	E	M	M <sub>1</sub>	M <sub>2</sub>	EUR	Y4	NCG	H5G / -S / -Z	X5G-Z / -S	ESG 4	ESG 5	HDG 2	ZSG 4	ZSG mini	DSG 4	Verso	HSG	
80	80		28	25			40			135,00	80 878 810				●	●					●		
125	125		40	37			66			224,00	80 901 303				●	●					●		
160	160		50	47			81			404,00	80 878 610				●	●							

### Blokbeek, vast

▲ prijs per stuk

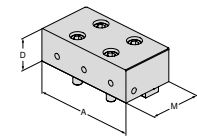

voor basisbreedte	A	A <sub>1</sub>	D	D <sub>1</sub>	D <sub>2</sub>	E	M	M <sub>1</sub>	M <sub>2</sub>	EUR	Y4	NCG	H5G / -S / -Z	X5G-Z / -S	ESG 4	ESG 5	HDG 2	ZSG 4	ZSG mini	DSG 4	Verso	HSG	
80	80		28				40			251,00	80 901 31200				●	●							
125	125		40				66			349,00	80 901 31400				●	●							
160	160		50				81			441,00	80 901 31600				●	●							

### Blokbeek, los

▲ prijs per stuk

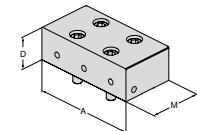

voor basisbreedte	A	A <sub>1</sub>	D	D <sub>1</sub>	D <sub>2</sub>	E	M	M <sub>1</sub>	M <sub>2</sub>	EUR	Y4	NCG	H5G / -S / -Z	X5G-Z / -S	ESG 4	ESG 5	HDG 2	ZSG 4	ZSG mini	DSG 4	Verso	HSG	
80	80		28				40			244,00	80 901 31300				●	●					●		
125	125		40				66			342,00	80 901 31500				●	●					●		
160	160		50				81			430,00	80 901 31700				●	●							

## Overzicht systeembekken

### Aluminium bek, vast

- ▲ voor het maken van vormbekken
- ▲ prijs per stuk

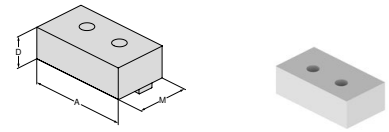

voor basisbreedte	A	A <sub>1</sub>	D	D <sub>1</sub>	D <sub>2</sub>	E	M	M <sub>1</sub>	M <sub>2</sub>	EUR	Y4	NCG	H5G / -S / -Z	X5G-Z / -S	ESG 4	ESG 5	HDC 2	ZSG 4	ZSG mini	DSG 4	Versto	HSG		
80	80		28				48			101,00	<b>80 901 307</b>				●	●								
125	125		40				68			110,00	<b>80 901 304</b>				●	●								
160	160		50				85			124,00	<b>80 901 301</b>				●	●								

### Zachte opzetbek (aluminium)

- ▲ voor het maken van vormbekken
- ▲ prijs per stuk

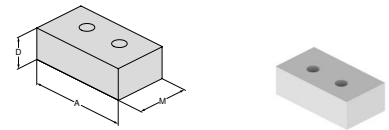

voor basisbreedte	A	A <sub>1</sub>	D	D <sub>1</sub>	D <sub>2</sub>	E	M	M <sub>1</sub>	M <sub>2</sub>	EUR	Y4	NCG	H5G / -S / -Z	X5G-Z / -S	ESG 4	ESG 5	HDC 2	ZSG 4	ZSG mini	DSG 4	Versto	HSG		
80	80		28				48			86,40	<b>80 878 850</b>				●	●		●			●			
125	125		40				68			98,30	<b>80 878 550</b>				●	●					●			
160	160		50				85			124,00	<b>80 878 305</b>				●	●		●						

### Zachte bek, staal, vast

- ▲ materiaal: 16MnCr5
- ▲ voor het maken van vormbekken
- ▲ prijs per stuk

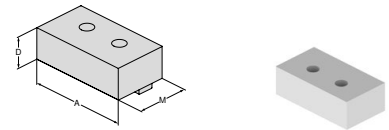

voor basisbreedte	A	A <sub>1</sub>	D	D <sub>1</sub>	D <sub>2</sub>	E	M	M <sub>1</sub>	M <sub>2</sub>	EUR	Y4	NCG	H5G / -S / -Z	X5G-Z / -S	ESG 4	ESG 5	HDC 2	ZSG 4	ZSG mini	DSG 4	Versto	HSG		
80	80		28				48			104,00	<b>80 901 31800</b>				●	●								
125	125		40				68			125,00	<b>80 901 31900</b>				●	●								

### Zachte bek, staal, los

- ▲ materiaal: 16MnCr5
- ▲ voor het maken van vormbekken
- ▲ prijs per stuk

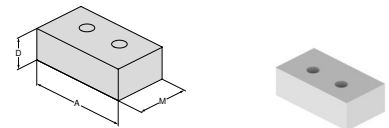

voor basisbreedte	A	A <sub>1</sub>	D	D <sub>1</sub>	D <sub>2</sub>	E	M	M <sub>1</sub>	M <sub>2</sub>	EUR	Y4	NCG	H5G / -S / -Z	X5G-Z / -S	ESG 4	ESG 5	HDC 2	ZSG 4	ZSG mini	DSG 4	Versto	HSG		
80	80		28				48			89,10	<b>80 878 32000</b>				●	●		●						
125	125		40				68			112,00	<b>80 878 32100</b>				●	●		●						

## Overzicht systeembekken

### Gripbek, breedte 40 mm, vast

- ▲ prijs per stuk
- ▲ dubbelzijdige getrapte gripbek

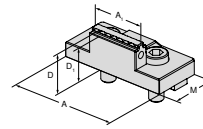

voor basisbreedte	A	A <sub>1</sub>	D	D <sub>1</sub>	D <sub>2</sub>	E	M	M <sub>1</sub>	M <sub>2</sub>
80	80	40	28	25			40		

EUR 196,00

Y4 80 901 308

NCG	H5G / -S / -Z	X5G-Z / -S	ESG 4	ESG 5	HDG 2	ZSG 4	ZSG mini	DSG 4	Verzo	HSG
			●							

### Gripbek 3 mm, breedte 40 mm, los

- ▲ prijs per stuk

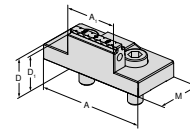

voor basisbreedte	A	A <sub>1</sub>	D	D <sub>1</sub>	D <sub>2</sub>	E	M	M <sub>1</sub>	M <sub>2</sub>
80	80	40	28	25			40		

EUR 180,00

Y4 80 878 81900

NCG	H5G / -S / -Z	X5G-Z / -S	ESG 4	ESG 5	HDG 2	ZSG 4	ZSG mini	DSG 4	Verzo	HSG
			●			●				

### 5-As gripbek, breedte 65 mm, vast

- ▲ prijs per stuk
- ▲ dubbelzijdige getrapte gripbek

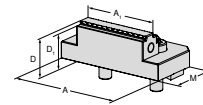

voor basisbreedte	A	A <sub>1</sub>	D	D <sub>1</sub>	D <sub>2</sub>	E	M	M <sub>1</sub>	M <sub>2</sub>
125	95	65	33	30			57		

EUR 214,00

Y4 80 901 305

NCG	H5G / -S / -Z	X5G-Z / -S	ESG 4	ESG 5	HDG 2	ZSG 4	ZSG mini	DSG 4	Verzo	HSG
			●							

### Gripbek 3 mm, breedte 65 mm, los

- ▲ dubbelzijdige getrapte gripbek
- ▲ prijs per stuk

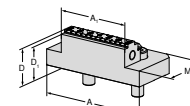

voor basisbreedte	A	A <sub>1</sub>	D	D <sub>1</sub>	D <sub>2</sub>	E	M	M <sub>1</sub>	M <sub>2</sub>
125	95	65	33	30			57		

EUR 196,00

Y4 80 878 51900

NCG	H5G / -S / -Z	X5G-Z / -S	ESG 4	ESG 5	HDG 2	ZSG 4	ZSG mini	DSG 4	Verzo	HSG
						●				



# Overzicht systeembekken

## Pendelbek, los

- ▲ voor opname van 6-voudige bekken
- ▲ prijs per stuk

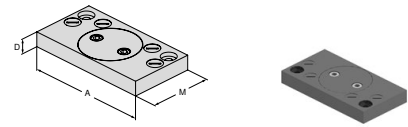

voor basisbreedte	A	A <sub>1</sub>	D	D <sub>1</sub>	D <sub>2</sub>	E	M	M <sub>1</sub>	M <sub>2</sub>	EUR	Y4	NCG	H5G / -S / -Z	X5G-Z / -S	ESG 4	ESG 5	HDG 2	ZSG 4	ZSG mini	DSG 4	Versto	HSG	
80	125		19				76			409,00	80 878 870				●				●	●			
125	180		22				95			426,00	80 878 570				●				●	●			
160	256		22				170			726,00	80 878 670				●				●	●			

## Adapterbek

- ▲ voor opname van 6-voudige bekken
- ▲ prijs per stuk

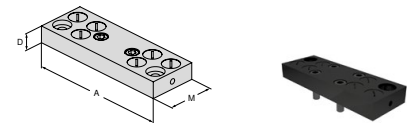

voor basisbreedte	A	A <sub>1</sub>	D	D <sub>1</sub>	D <sub>2</sub>	E	M	M <sub>1</sub>	M <sub>2</sub>	EUR	Y4	NCG	H5G / -S / -Z	X5G-Z / -S	ESG 4	ESG 5	HDG 2	ZSG 4	ZSG mini	DSG 4	Versto	HSG	
80	125		19				48			291,00	80 901 501				●								
125	180		22				62			346,00	80 901 502				●								
160	256		22				125			484,00	80 901 503				●								

## 6-voudige bek

- ▲ 1 = glad, wolframcarbide gecoat
- ▲ 2 = grip met trap 3 mm
- ▲ 3 = grip met trap 8 mm
- ▲ 4 = grip met trap 18 mm
- ▲ 5 = grip met trap 8 mm
- ▲ 6 = grip rond
- ▲ M<sub>max</sub> = 60 Nm
- ▲ incl. bevestigingsbout

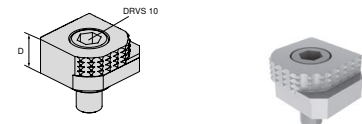

voor basisbreedte	A	A <sub>1</sub>	D	D <sub>1</sub>	D <sub>2</sub>	E	M	M <sub>1</sub>	M <sub>2</sub>	EUR	Y4	NCG	H5G / -S / -Z	X5G-Z / -S	ESG 4	ESG 5	HDG 2	ZSG 4	ZSG mini	DSG 4	Versto	HSG	
			18							80,60	80 892 246	●	●	●	●				●		●	●	

## 6-voudige bek

- ▲ 1 = glad
- ▲ 2 = carbide grip
- ▲ 3 = carbide grip met trap 3 mm
- ▲ 4 = carbide grip met trap 8 mm
- ▲ 5 = carbide grip rond met trap 8 mm
- ▲ 6 = carbide grip rond
- ▲ incl. bevestigingsbout

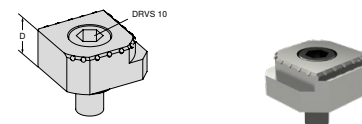

voor basisbreedte	A	A <sub>1</sub>	D	D <sub>1</sub>	D <sub>2</sub>	E	M	M <sub>1</sub>	M <sub>2</sub>	EUR	Y4	NCG	H5G / -S / -Z	X5G-Z / -S	ESG 4	ESG 5	HDG 2	ZSG 4	ZSG mini	DSG 4	Versto	HSG	
			18							117,00	80 890 35300	●	●	●	●				●		●	●	

## ESG 5

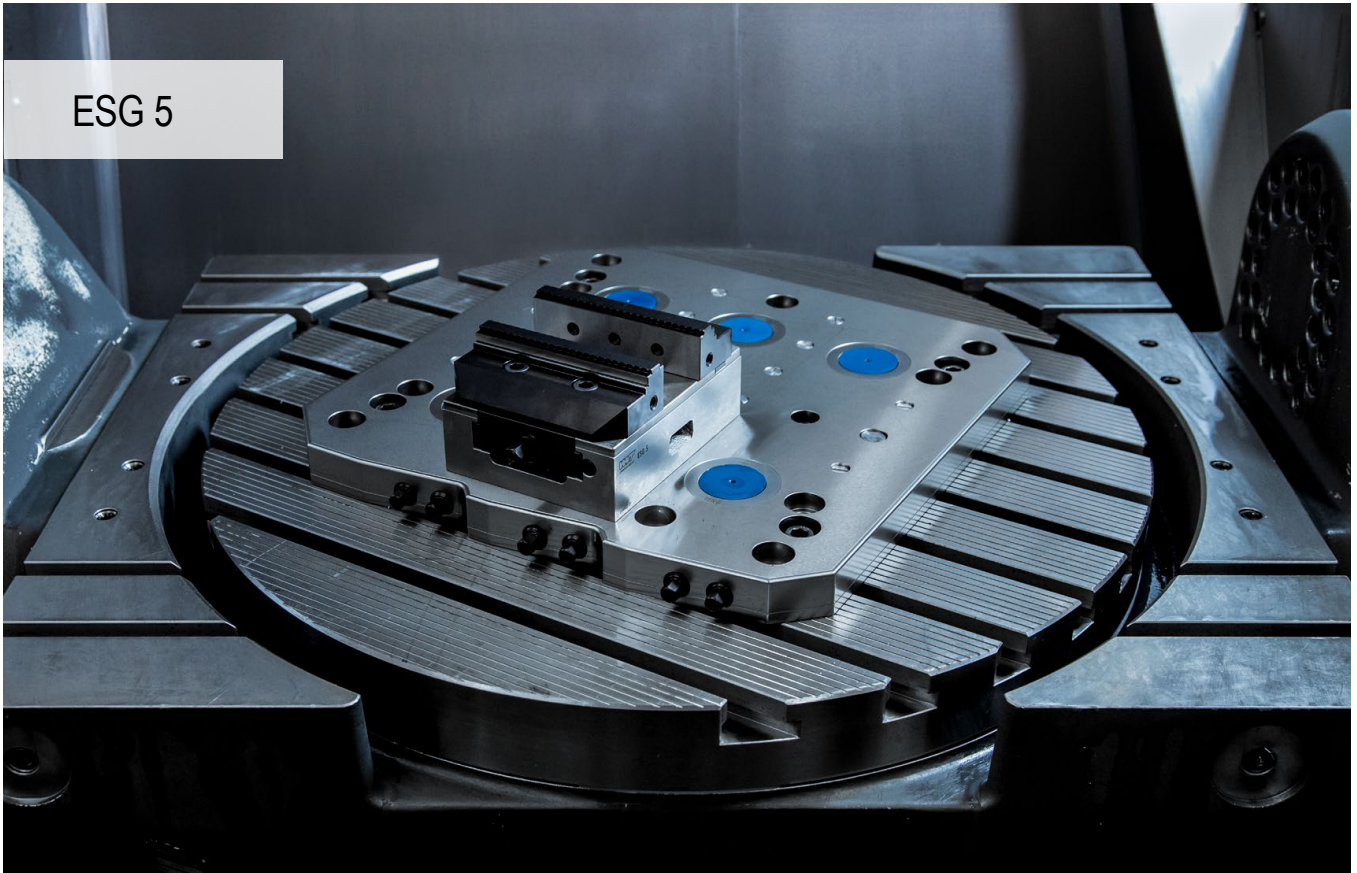

## De geoptimaliseerde ESG 5 – Maximale precisie en proceszekerheid

De nieuwe ESG 5 erft alle beste kenmerken van zijn voorganger en legt de lat nog hoger op gebied van gebruiksvriendelijkheid en duurzaamheid. Geoptimaliseerd gebruiksgemak en verbeterde duurzaamheid waren topprioriteiten bij het updaten van deze populaire enkelspanner.

## Uw voordelen:

- ▲ afgeschermd spindel – gesloten systeem, hoge proceszekerheid
- ▲ compact ontwerp met beste toegankelijkheid
- ▲ Eenvoudige en dus snelle bekkenwissel, simpelweg met 2 schroeven
- ▲ hoge nauwkeurigheid door spelingsvrije lagering
- ▲ groter klembereik, veel betere toegankelijkheid, omvangrijkste aanbod systeembekken
- ▲ duurzaam systeem met een vernikkelde body zorgt voor een lange levensduur

## Opspannen / uitlijnen:



Bevestiging met nulpunt-spansysteem  
ESG 5 – 80 mm + L-190 mm  
ESG 5 – 125 mm + L-160 mm + L-235 mm

1 opnamepen + MNG-indexeerpennen



Bevestiging met nulpunt-spansysteem  
ESG 5 – 125 mm + L-300 mm  
ESG 5 – 160 mm + L-280 mm + L-480 mm

2 opnamepennen



In alle varianten zijn altijd  $\text{Ø } 12^{\text{H}}$  precisieboringen aanwezig, waarmee de ESG 5 exact gepositioneerd kan worden. Alle varianten kunnen met bouten van boven door de basis bevestigd worden.

## Opspannen / uitlijnen:



ESG 5 – 125 mm L-235 mm + L-300 mm  
ESG 5 – 160 mm L-280 mm + L-480 mm

Deze 4 varianten kunnen ook met klemvingers opgespannen worden.

## Spankracht:

Aantrekmoment / spankracht ESG 5 – 80 mm

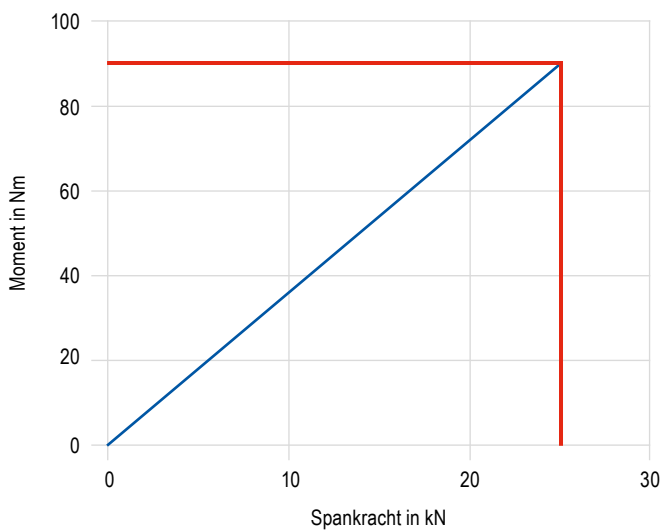

Aantrekmoment / spankracht ESG 5 – 125 mm

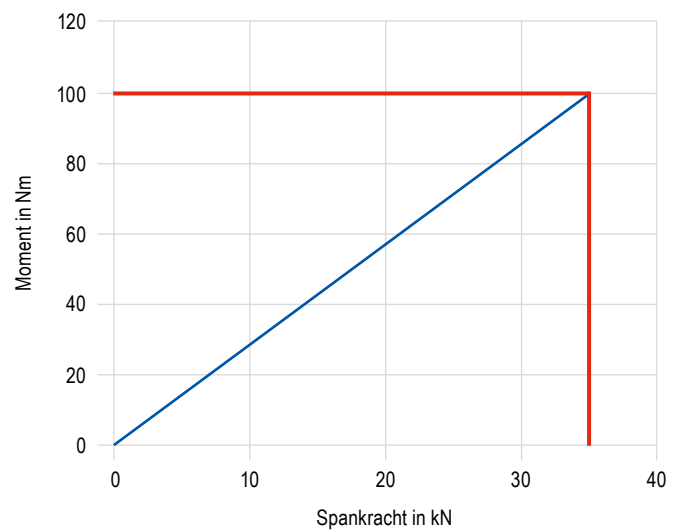

Aantrekmoment / spankracht ESG 5 – 160 mm

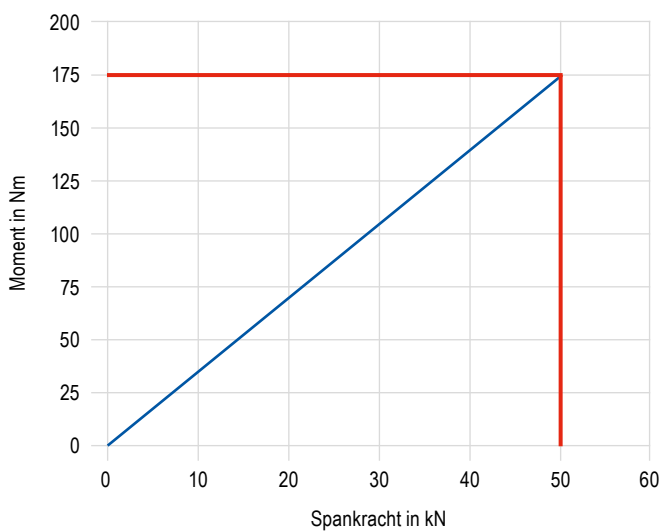

# SoloClamp – ESG 5

- ▲ Enkelspanner zonder systeembekken
- ▲ kogelgelagerde spindel
- ▲ ± 0,01 mm repeteernauwkeurigheid
- ▲ passend voor PNG er MNG

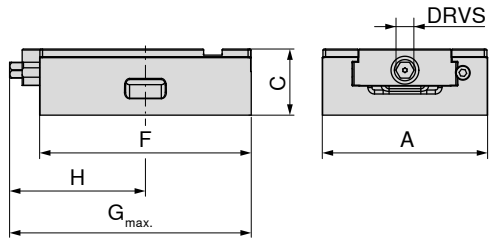

A	C ±0.01	F	G <sub>max.</sub>	H	DRVS	MXC	WT	80 857 ...	
mm	mm	mm	mm	mm	mm	kN	kg	EUR	Y4
80	50	130	155,0	82	12	25	2,9	553,00	08500
80	50	190	203,0	102	12	25	4,4	665,00	08600
125	50	160	169,0	103	12	35	6,0	726,00	15000
125	50	235	235,0	132	12	35	8,4	927,00	15100
125	50	300	300,0	170	12	35	10,5	1.230,00	15200
160	70	280	309,0	169	14	50	25,0	1.710,00	26100
160	70	480	512,5	267	14	50	30,0	2.040,00	26200

passend voor nulpuntspansystemen							LANG Quick Point		LANG Quick Point	
Artikel-nr.	type	Breedte in mm	Hoogte in mm	MNG	MNG mini	PNG	96 x 96		52 x 52	
80 857 08500	ESG 5	80	130	✓	✓	✗	✗		✓	
80 857 08600		80	190	✓	✗	✓	✗		✓	
80 857 15000		125	160	✓	✗	✓	✓		✓	
80 857 15100		125	235	✓	✗	✓	✓		✗	
80 857 15200		125	300	✓	✗	✓	✓		✗	
80 857 26100		160	280	✓	✗	✓	✓		✗	
80 857 26200		160	480	✓	✗	✓	✗		✗	

*Klemmengids*

Maten van de onderzijde	63+64	Maattabellen voor de verschillende bekken	65
Systeem-toebehoren	66	MNG-/PNG nulpuntspansysteem	134-163
Algemeen toebehoren	164-183		

## SoloClamp – ESG 5

- ▲ Ingekapselfde enkelspanner voor Erowa ITS 148
- ▲ zonder systeembekken
- ▲ kogelgelagerde spindel
- ▲  $\pm 0,01$  mm repeeteernauwkeurigheid

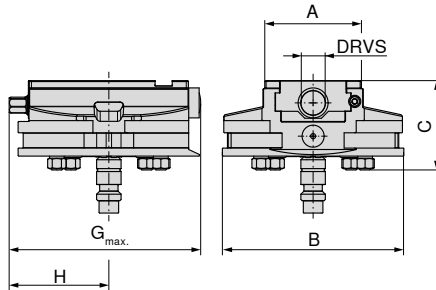
ESG  
5

80 857 ...

EUR  
Y4

1.370,00 08900

A	B	C	G <sub>max.</sub>	H	DRVS	MXC	WT
mm	mm	mm	mm	mm	mm	kN	kg
80	148	73	157	81	12	25	5,6

### Klemmengids

Maten van de onderzijde	63+64	Maattabellen voor de verschillende bekken	65
Systeem-toebehoren	66	MNG-/PNG nulpuntspansysteem	134-163
Algemeen toebehoren	164-183		

## Maten van de onderzijde van ESG 5

Basisbreedte 80 mm en lengte 130 mm

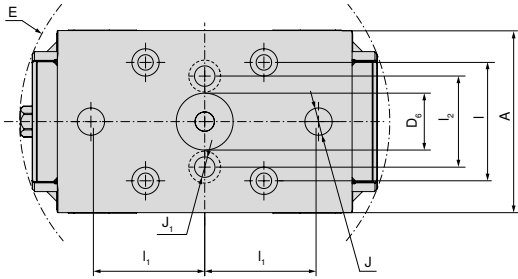

A	D <sub>6</sub> H <sub>6</sub>	E	I <sub>1</sub> ±0.015	I <sub>1</sub> ±0.015	I <sub>2</sub>	J H <sub>7</sub>	J <sub>1</sub>
mm	mm	mm	mm	mm	mm	mm	mm
80	25	163	52	50	40	12	9

Basisbreedte 80 mm en lengte 190 mm

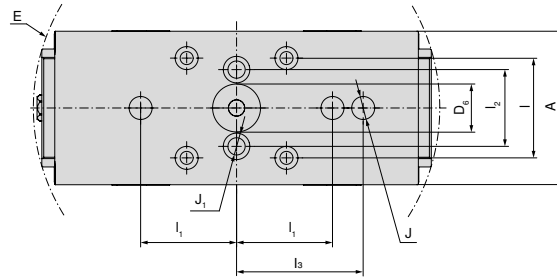

A	D <sub>6</sub> H <sub>6</sub>	E	I <sub>1</sub> ±0.015	I <sub>1</sub> ±0.015	I <sub>2</sub>	I <sub>3</sub> ±0.015	J H <sub>7</sub>	J <sub>1</sub>
mm	mm	mm	mm	mm	mm	mm	mm	mm
80	25	213	52	50	40	66	12	9

Basisbreedte 125 mm en lengte 160 mm

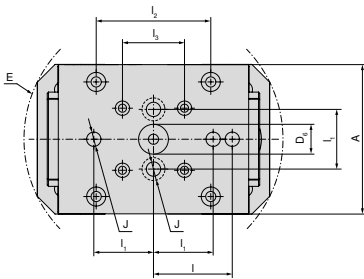

A	D <sub>6</sub> H <sub>6</sub>	E	I <sub>1</sub> ±0.015	I <sub>1</sub> ±0.015	I <sub>2</sub>	I <sub>3</sub> ±0.015	J H <sub>7</sub>
mm	mm	mm	mm	mm	mm	mm	mm
125	25	218	66	50	96	52	12

Basisbreedte 125 mm en lengte 235 mm

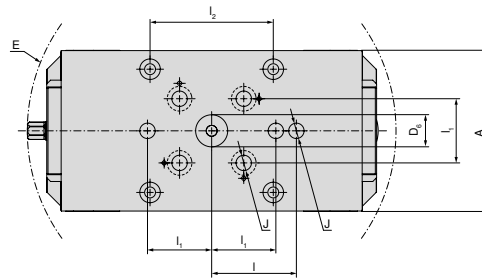

A	D <sub>6</sub> H <sub>6</sub>	E	I <sub>1</sub> ±0.015	I <sub>1</sub> ±0.015	I <sub>2</sub>	J H <sub>7</sub>
mm	mm	mm	mm	mm	mm	mm
125	25	288	66	50	96	12

Basisbreedte 125 mm en lengte 300 mm

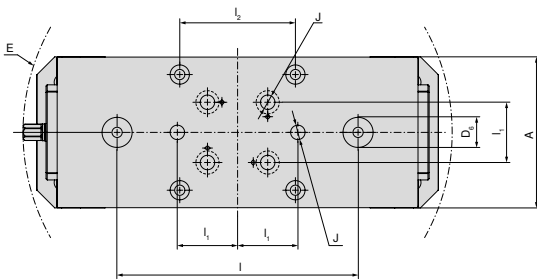

A	D <sub>6</sub> H <sub>6</sub>	E	I <sub>1</sub> ±0.015	I <sub>1</sub> ±0.015	I <sub>2</sub>	J H <sub>7</sub>
mm	mm	mm	mm	mm	mm	mm
125	25	357	200	50	96	12

## Maten van de onderzijde van ESG 5

Basisbreedte 160 mm en lengte 280 mm

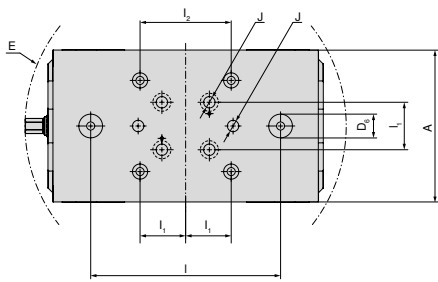

A	D <sub>6</sub> H <sub>6</sub>	E	I <sub>1</sub> ±0.015	I <sub>2</sub> ±0.015	I <sub>2</sub>	J H <sub>7</sub>
mm	mm	mm	mm	mm	mm	mm
160	25	339	200	50	96	12

Basisbreedte 160 mm en lengte 480 mm

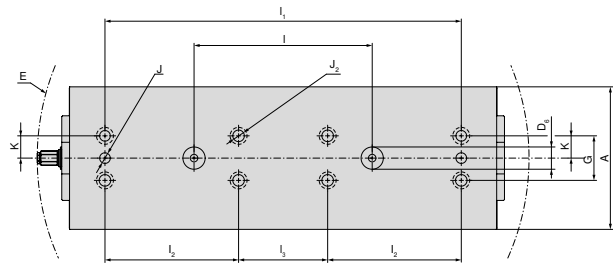

A	D <sub>6</sub> H <sub>6</sub>	E	I <sub>1</sub> ±0.015	I <sub>2</sub> ±0.015	I <sub>2</sub>	I <sub>3</sub> ±0.015	J H <sub>7</sub>	J <sub>2</sub> F <sub>7</sub>	K ±0.02	G
mm	mm	mm	mm	mm	mm	mm	mm	mm	mm	mm
160	25	553	200	400	150	100	12	12	25	50

# ESG 5 maattabellen voor de verschillende bekken

met vaste en losse gripbekken 3 mm

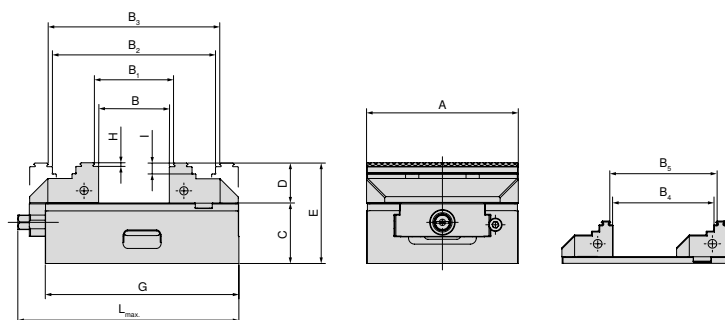

A mm	B mm	B <sub>1</sub> mm	B <sub>2</sub> mm	B <sub>3</sub> mm	B <sub>4</sub> mm	B <sub>5</sub> mm	C mm	D mm	E mm	G mm	H mm	I mm	L <sub>max.</sub> mm	Artikel-nr. Systeembekken
80	0-49	4-53	59-107	63-111	30-78	34-82	50	28	78	130	3	8	155	80 901 306 + 80 878 810
80	0-109	4-113	59-167	63-171	29-134	35-136	50	28	78	190	3	8	206	80 901 306 + 80 878 810
125	0-57	8-64	77-134	84-141	40-95	47-102	50	33	83	160	3	9	183	80 857 30000 + 80 878 510
125	0-127	8-134	77-204	84-211	40-165	47-172	50	33	83	235	3	9	250	80 857 30000 + 80 878 510
125	0-197	8-204	77-274	84-281	40-235	47-242	50	33	83	300	3	9	320	80 857 30000 + 80 878 510
160	0-121	8-128	118-238	125-245	-	-	70	50	120	280	3	10	328	80 901 300 + 80 878 610
160	0-324	8-331	118-441	125-448	-	-	70	50	120	480	3	10	506	80 901 300 + 80 878 610

met 5-As bekken

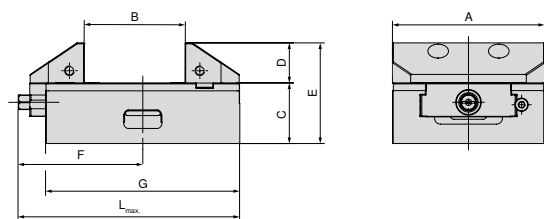

A mm	B mm	C mm	D mm	E mm	F mm	G mm	L <sub>max.</sub> mm	Artikel-nr. Systeembekken
125	25-82	50	33	83	103	160	183	80 857 30200 + 80 857 30100
125	25-152	50	33	83	132	235	250	80 857 30200 + 80 857 30100
125	25-222	50	33	83	170	300	320	80 857 30200 + 80 857 30100



# Overzicht systeembekken

## Vaste bek, glad

▲ prijs per stuk

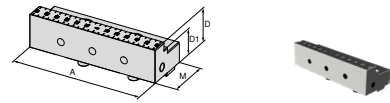

voor basisbreedte	A	A <sub>1</sub>	D	D <sub>1</sub>	D <sub>2</sub>	E	M	M <sub>1</sub>	M <sub>2</sub>	EUR	Y4	NCG	H5G / -S / -Z	X5G-Z / -S	ESG 4	ESG 5	HDG 2	ZSG 4	ZSG mini	DSG 4	Verso	HSG	
80	80		28	20			40			195,00	80 857 30400					●							
125	125		33	25			57			378,00	80 857 30300					●							

## Losse bek, glad

▲ prijs per stuk

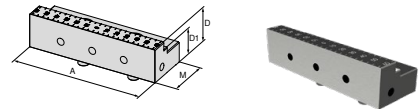

voor basisbreedte	A	A <sub>1</sub>	D	D <sub>1</sub>	D <sub>2</sub>	E	M	M <sub>1</sub>	M <sub>2</sub>	EUR	Y4	NCG	H5G / -S / -Z	X5G-Z / -S	ESG 4	ESG 5	HDG 2	ZSG 4	ZSG mini	DSG 4	Verso	HSG	
80	80		28	20			40			195,00	80 878 34700					●							
125	125		33	25			57			378,00	80 878 34600					●		●					

## Gripbek 3 mm, vast

▲ prijs per stuk

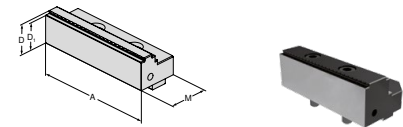

voor basisbreedte	A	A <sub>1</sub>	D	D <sub>1</sub>	D <sub>2</sub>	E	M	M <sub>1</sub>	M <sub>2</sub>	EUR	Y4	NCG	H5G / -S / -Z	X5G-Z / -S	ESG 4	ESG 5	HDG 2	ZSG 4	ZSG mini	DSG 4	Verso	HSG	
80	80		28	25			40			163,00	80 901 306				●	●							
125	125		33	30			57			222,00	80 857 30000				●	●							
160	160		50	47			81			404,00	80 901 300				●	●							

## Gripbek 3 mm, los

▲ prijs per stuk

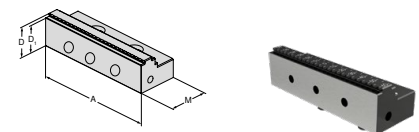

voor basisbreedte	A	A <sub>1</sub>	D	D <sub>1</sub>	D <sub>2</sub>	E	M	M <sub>1</sub>	M <sub>2</sub>	EUR	Y4	NCG	H5G / -S / -Z	X5G-Z / -S	ESG 4	ESG 5	HDG 2	ZSG 4	ZSG mini	DSG 4	Verso	HSG	
80	80		28	25			40			135,00	80 878 810				●	●							
125	125		33	30			57			151,00	80 878 510				●	●							
160	160		50	47			81			404,00	80 878 610				●	●							

# Overzicht systeembekken

## 5-As bek, vast

▲ prijs per stuk

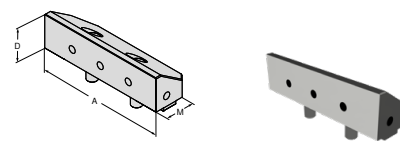

voor basisbreedte	A	A <sub>1</sub>	D	D <sub>1</sub>	D <sub>2</sub>	E	M	M <sub>1</sub>	M <sub>2</sub>	EUR	Y4	NCG	H5G / -S / -Z	X5G-Z / -S	ESG 4	ESG 5	HDG 2	ZSG 4	ZSG mini	DSG 4	Verro	HSG	
125	125		33				44,5			224,00						●							
											<b>80 857 30100</b>												

## 5-As bek, los

▲ prijs per stuk

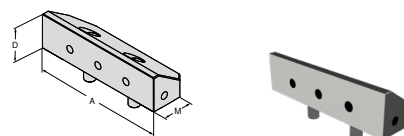

voor basisbreedte	A	A <sub>1</sub>	D	D <sub>1</sub>	D <sub>2</sub>	E	M	M <sub>1</sub>	M <sub>2</sub>	EUR	Y4	NCG	H5G / -S / -Z	X5G-Z / -S	ESG 4	ESG 5	HDG 2	ZSG 4	ZSG mini	DSG 4	Verro	HSG	
125	125		33				44,5			224,00						●							
											<b>80 857 30200</b>												

## Zachte bek, staal, vast

- ▲ materiaal: 16MnCr5
- ▲ voor het maken van vormbekken
- ▲ prijs per stuk

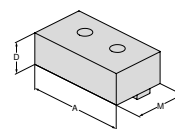

voor basisbreedte	A	A <sub>1</sub>	D	D <sub>1</sub>	D <sub>2</sub>	E	M	M <sub>1</sub>	M <sub>2</sub>	EUR	Y4	NCG	H5G / -S / -Z	X5G-Z / -S	ESG 4	ESG 5	HDG 2	ZSG 4	ZSG mini	DSG 4	Verro	HSG	
80	80		28				48			104,00					●	●							
125	125		40				68			125,00					●	●							
											<b>80 901 31800</b>												
											<b>80 901 31900</b>												

## Zachte bek, staal, los

- ▲ materiaal: 16MnCr5
- ▲ voor het maken van vormbekken
- ▲ prijs per stuk

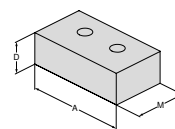

voor basisbreedte	A	A <sub>1</sub>	D	D <sub>1</sub>	D <sub>2</sub>	E	M	M <sub>1</sub>	M <sub>2</sub>	EUR	Y4	NCG	H5G / -S / -Z	X5G-Z / -S	ESG 4	ESG 5	HDG 2	ZSG 4	ZSG mini	DSG 4	Verro	HSG	
80	80		28				48			89,10					●	●							
125	125		40				68			112,00					●	●		●					
											<b>80 878 32000</b>												
											<b>80 878 32100</b>												

HDG 2

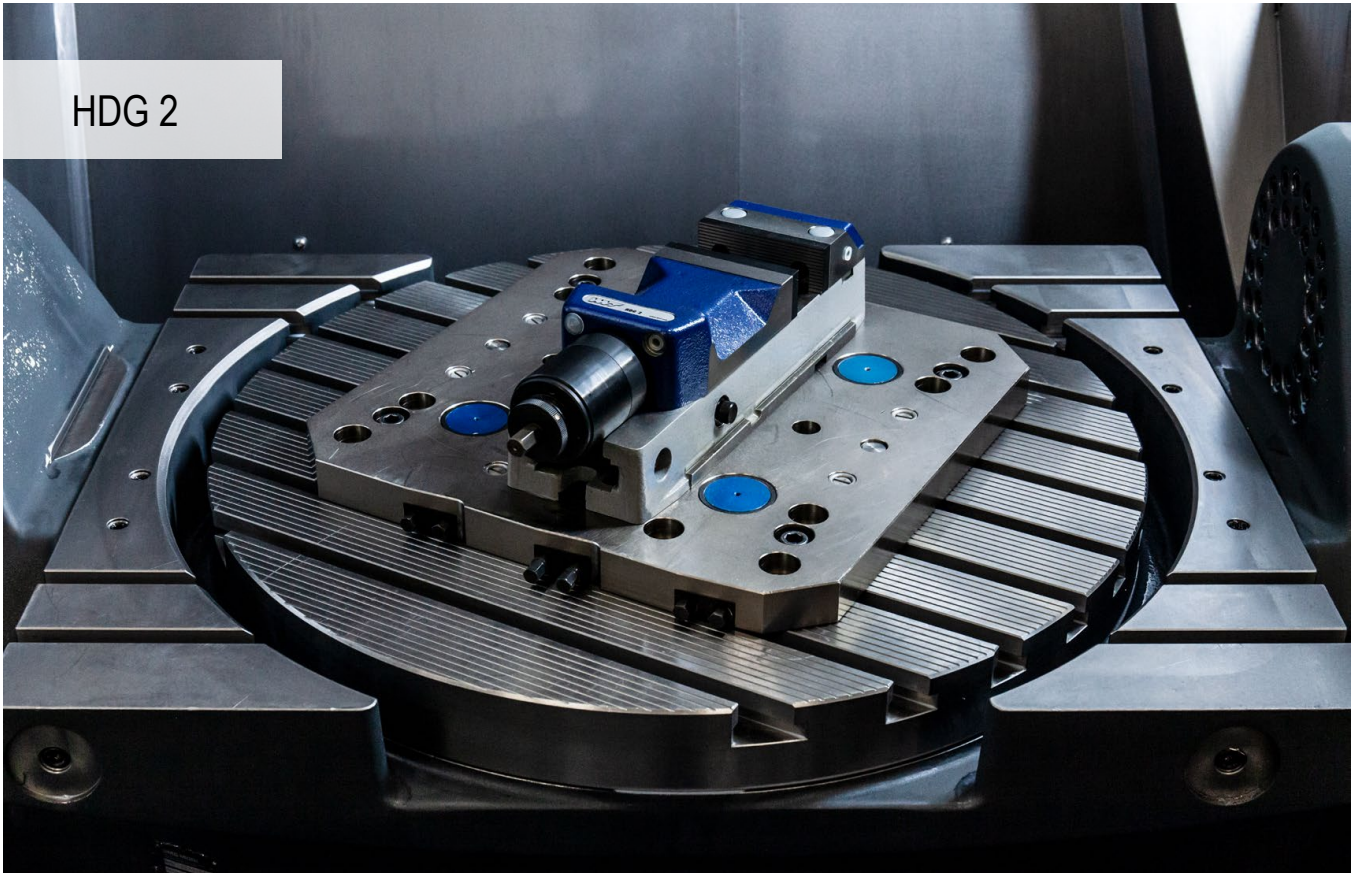

## Beproefd hoge druk spansysteem

Mechanische machineklem met traploze krachtinstelling van 10 tot 100% van de spankracht met slechts één omwenteling van de hendel en met altijd dezelfde eindpositie van de hendel. Snelle spanbereikverstelling door middel van pennen.

### Uw voordelen:

- ▲ tijd en kracht besparen – slecht 1 omwenteling van de hendel
- ▲ spantijd < 1 seconde
- ▲ eenvoudige handling
- ▲ traploos en zonder gereedschap in te stellen
- ▲ hoge bewerkingsprecisie

### Opspannen / uitlijnen:



Uitlijning op de tafel met behulp van precisie spanblokken en langs- resp. dwars sleuven 20<sup>H7</sup> in de basis



Opspannen met bouten door de basis of via de zijkant met klemvingers

# SoloClamp – HDG 2

- ▲ hogedruk spanner
- ▲ traploze krachtingstelling
- ▲ mechanische krachtoverbrenging
- ▲ spankracht met slechts één omwenteling
- ▲ losse bekken, voorberekt voor opname van bekken voor spanbereikvergroting

**leveromvang:**

hogedruk machineklem incl. 4 klemvingers, handkruk, 2 geprofileerde en geharde bekken

**HDG  
2**

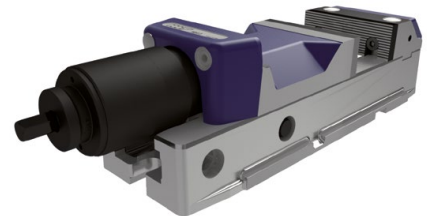
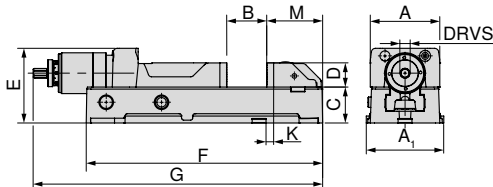

A	A <sub>1</sub>	B	C <sup>+0/-0.02</sup>	D	E	F	G <sub>max</sub>	K <sub>±0.015</sub>	M	DRVS	MXC	WT	80 892 ...
mm	mm	mm	mm	mm	mm	mm	mm	mm	mm	mm	kN	kg	EUR Y4
100	112	0 - 159	52	35	108	342	521	11	81	12	4 - 30	20	2.050,00 100
125	140	0 - 201	62	40	118	400	584	28	85	12	4 - 40	27	2.340,00 125
160	176	0 - 300	78	50	149	544	784	40	112	12	5 - 60	55	3.470,00 160

*Klemmengids*

Maten van de onderzijde	71	System-toebehoren	69-71
Algemeen toebehoren	164-183		

## Overzicht systeembekken

Bekken voor spanbereikvergroting

▲ prijs per set (1 vaste en 1 losse bek)

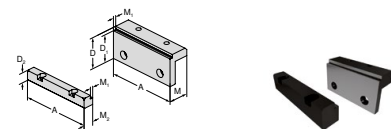

voor basisbreedte	A	A <sub>1</sub>	D	D <sub>1</sub>	D <sub>2</sub>	E	M	M <sub>1</sub>	M <sub>2</sub>	EUR	Y4	NCG	H5G / +S / -Z	X5G-Z / -S	ESG 4	ESG 5	HDG 2	ZSG 4	ZSG mini	DSG 4	Verso	HSG	
100			56	50	22		37	5	19	366,00	80 892 225							●					
125			56	50	22		37	5	19	494,00	80 892 226							●					
160			71	65	23		47	5	23,5	537,00	80 892 227							●					

## Afbeelding met vergroot spanbereik



A	B	D	artikelnummer machineklem	artikelnummer bekken
100	118 - 278	56	80 892 100	80 892 225
125	137 - 338	56	80 892 125	80 892 226
160	169 - 470	71	80 892 160	80 892 227

# SoloClamp – HDG 2

▲ basis verlenging

**HDG  
2**

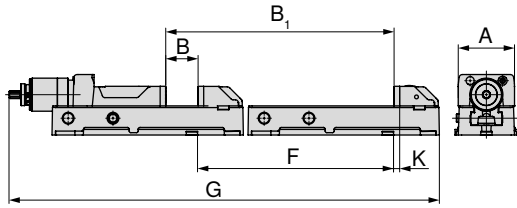

A	B	B <sub>1</sub>	F	G	K
mm	mm	mm	mm	mm	mm
100	0-159	350-509	450	871,3	11
125	0-201	410-611	410	994,1	28
160	0-300	550-850	550	1334,15	40

80 892 ...	
EUR	
Y4	
1.160,00	51000
1.280,00	51100
1.740,00	51200

## Afbeelding met basis verlenging

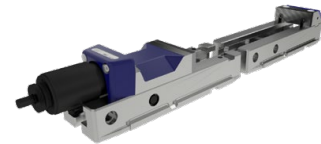

A	B	D	artikelnummer machineklem	artikelnummer verlenging
100	350 - 509	35	80 892 100	80 892 51000
125	410 - 611	40	80 892 125	80 892 51100
160	550 - 850	50	80 892 160	80 892 51200

## Maten van de onderzijde van HDG 2

Basisbreedte 100 mm, 125 mm, 160 mm

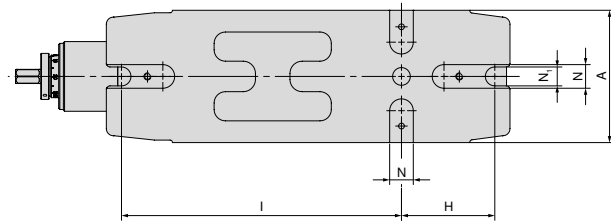

A mm	H mm	I mm	N <sub>H17</sub> mm	N <sub>1</sub> mm
100	80	240	20	15
125	100	280	20	18
160	130	380	20	22

## Overzicht systeem-toebehoren

### Haakse overbrenging

HDG  
2



80 892 ...

voor breedte mm	EUR Y4	
100/125	460,00	314
160	499,00	315

### Handkruk

▲ voor snelverstelling

HDG  
2



80 892 ...

voor breedte mm	DRVS mm	EUR Y4	
100/125	12	76,60	124
160	12	95,00	164

ZSG 4



## De geoptimaliseerde ZSG 4 – Maximale precisie en proceszekerheid

De nieuwe ZSG 4 erft alle beste kenmerken van zijn voorganger en legt de lat nog hoger op gebied van gebruiksvriendelijkheid en duurzaamheid. Geoptimaliseerd gebruiksgemak en verbeterde duurzaamheid waren topprioriteiten bij het updaten van deze populaire centrumspanner.

### Uw voordelen:

- ▲ afgeschermd spindel – gesloten systeem, hoge proceszekerheid
- ▲ compact ontwerp met beste toegankelijkheid
- ▲ Eenvoudige en dus snelle bekkenwissel, simpelweg met 2 schroeven
- ▲ hoge nauwkeurigheid door spelingsvrije lagering
- ▲ groter klembereik, veel betere toegankelijkheid, omvangrijkste aanbod systeembekken
- ▲ duurzaam systeem met een vernikkelde body zorgt voor een lange levensduur



### Opspannen / uitlijnen:



Bevestiging met nulpunt-spansysteem  
ZSG 4 – 80 mm + L-190 mm  
ZSG 4 – 125 mm + L-160 mm + L-235 mm

1 opnamepen + MNG-indexeerpennen



Bevestiging met nulpunt-spansysteem  
ZSG 4 – 125 mm + L-300 mm  
ZSG 4 – 160 mm + L-280 mm + L-480 mm

2 opnamepennen



In alle varianten zijn altijd  $\text{Ø } 12^{\text{H}}$  precisieboringen aanwezig, waarmee de ZSG 4 exact gepositioneerd kan worden. Alle varianten kunnen met bouten van boven door de basis bevestigd worden.

## Opspannen / uitlijnen:



ZSG 4 – 125 mm L-235 mm + L-300 mm  
ZSG 4 – 160 mm L-280 mm + L-480 mm

Deze 4 varianten kunnen ook met  
klemvingers opgespannen worden.



ZSG 4 – 80 mm L-130 mm + L-190 mm  
ZSG 4 – 125 mm L-160 mm + L-235 mm + L-300 mm  
ZSG 4 – 160 mm L-280 mm

Alle 5 varianten zijn ook verkrijgbaar met opnameboringen  
voor het LANG-nulpunt spansysteem.

## Spankracht:

Aantrekmoment / spankracht ZSG 4 – 80 mm

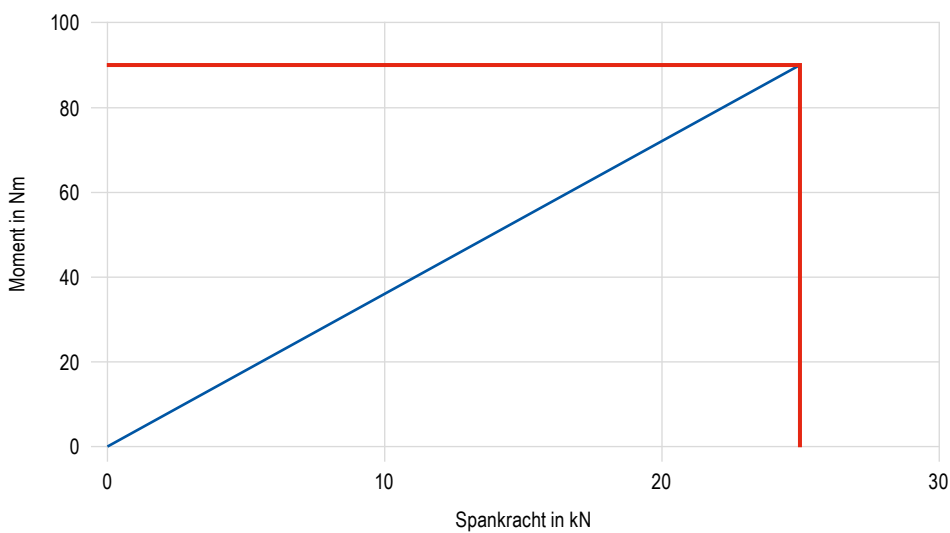



## Spankracht:

## Aantrekmoment / spankracht ZSG 4 – 125 mm

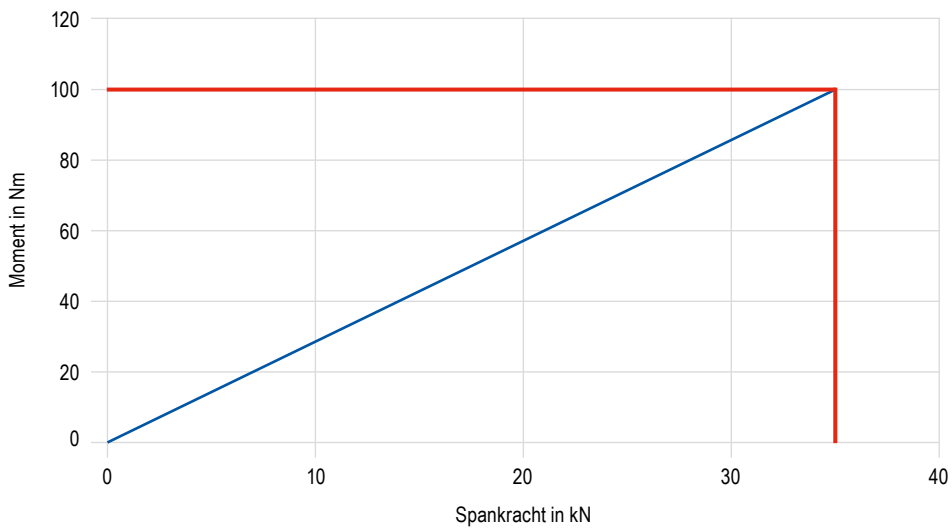

## Aantrekmoment / spankracht ZSG 4 – 160 mm

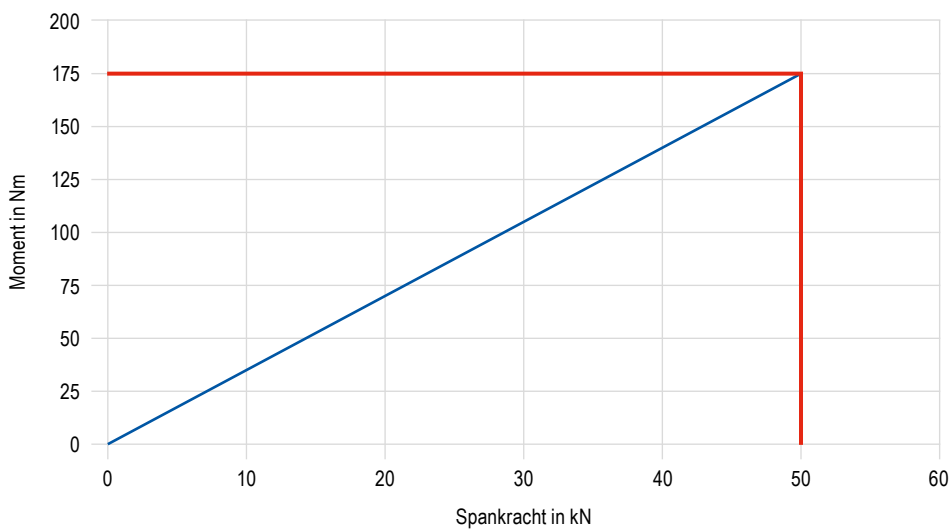

# CentriClamp – ZSG 4

- ▲ Ingekapselde centrumspanner
- ▲ zonder systeembekken
- ▲ kogelgelagerde spindel
- ▲ ± 0,01 mm repeteernauwkeurigheid
- ▲ passend voor PNG er MNG

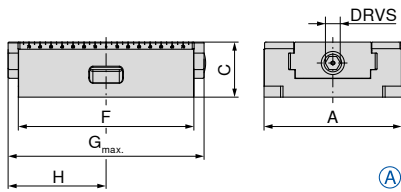

interne aandrijfspindel

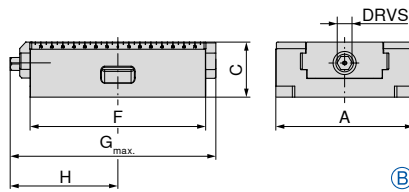

externe aandrijfspindel



A	C ±0.01	F	G <sub>max</sub>	H	DRVS	MXC	WT	omschrijving	80 878 ...
mm	mm	mm	mm	mm	mm	kN	kg		EUR Y4
80	50	130	157	81	12	25	3,1	A	553,00 08500
80	50	190	206	104	12	25	4,5	B	665,00 08600
125	50	160	200	111,5	12	35	6,3	A	726,00 15000
125	50	235	272	143,5	12	35	9,5	B	927,00 15100
125	50	300	340	181	12	35	12,5	B	1.130,00 15200
160	70	280	315	172	14	50	25,0	A	1.710,00 26100
160	70	480	524	276	14	50	35,0	B	3.230,00 26200

Artikel-nr.	passend voor nulpuntspansystemen			MNG	MNG mini	PNG	LANG Quick Point	
	type	Breedte in mm	Lengte in mm				96 x 96	52 x 52
80 878 08500	ZSG 4	80	130	✓	✓	✗	✗	✓
80 878 08600		80	190	✓	✗	✓	✗	✓
80 878 15000		125	160	✓	✗	✓	✓	✓
80 878 15100		125	235	✓	✗	✓	✓	✗
80 878 15200		125	300	✓	✗	✓	✓	✗
80 878 26100		160	280	✓	✗	✓	✓	✗
80 878 26200		160	480	✓	✗	✓	✗	✗

**Klemmengids**

Maten van de onderzijde	78-79	Maattabellen voor de verschillende bekken	80-83
Systeem-toebehoren	85-90	MNG-/PNG nulpuntspansysteem	134-163
Algemeen toebehoren	164-183		

# CentriClamp – ZSG 4

- ▲ Ingekapselde centrumspanner
- ▲ met getrapte 3 mm gripbek
- ▲ kogelgelagerde spindel
- ▲ ± 0,01 mm repeeteernauwkeurigheid
- ▲ passend voor PNG er MNG

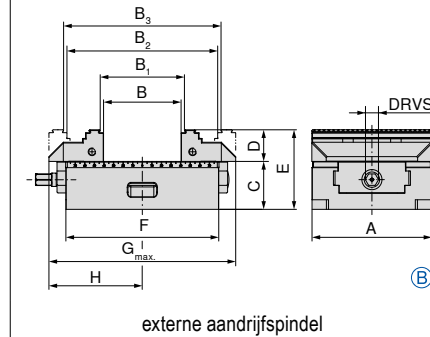
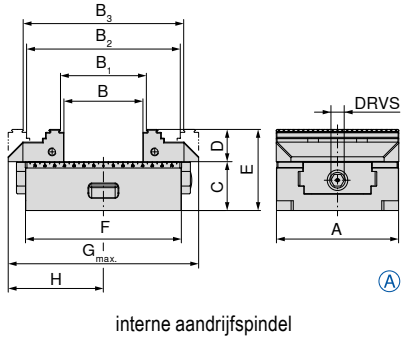
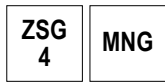

															80 878 ...	
A	B	B <sub>1</sub>	B <sub>2</sub>	B <sub>3</sub>	C ±0,01	D	E	F	G <sub>max</sub>	H	DRVS	MXC	WT	omschrijving	EUR	
mm	mm	mm	mm	mm	mm	mm	mm	mm	mm	mm	mm	kN	kg		Y4	
80	0 - 59	4 - 63	59 - 117	63 - 121	50	28	78	130	157	81	12	25	3,9	A	777,00	08700
80	0 - 123	4 - 127	59 - 181	63 - 185	50	28	78	190	206	104	12	25	5,5	B	889,00	08800
125	0 - 80	8 - 87	77 - 156	84 - 163	50	33	83	160	208	111,5	12	35	8,7	A	980,00	15300
125	0 - 155	8 - 162	77 - 218	84 - 225	50	33	83	235	272	143,5	12	35	12,0	B	1.180,00	15400
125	0 - 220	8 - 227	77 - 296	84 - 303	50	33	83	300	348	181	12	35	14,0	B	1.390,00	15500



Hier passen geen standaard 40 mm voorzetbekken op, indien benodigd dan bek D = 40 mm (80 878 520) gebruiken.

passend voor nulpuntspansystemen							LANG Quick Point		LANG Quick Point	
Artikel-nr.	type	Breedte in mm	Lengte in mm	MNG	MNG mini	PNG	96 x 96	52 x 52		
80 878 08700	ZSG 4	80	130	✓	✓	✗	✗	✓		
80 878 08800		80	190	✓	✗	✓	✗	✓		
80 878 15300		125	160	✓	✗	✓	✓	✓		
80 878 15400		125	235	✓	✗	✓	✓	✗		
80 878 15500		125	300	✓	✗	✓	✓	✗		

### Klemmengids

Maten van de onderzijde	78-79	Maattabellen voor de verschillende bekken	80-83
Systeem-toebehoren	85-90	MNG-/PNG nulpuntspansysteem	134-163
Algemeen toebehoren	164-183		

## CentriClamp – ZSG 4

- ▲ Ingekapselde enkelspanner voor Erowa ITS 148
- ▲ zonder systeembekken
- ▲ kogelgelagerde spindel
- ▲  $\pm 0,01$  mm repeteernauwkeurigheid

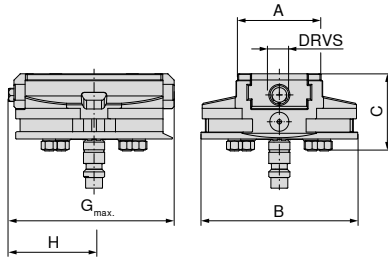
**ZSG  
4****MNG****80 878 ...****EUR  
Y4****1.370,00 08900**

A	B	C	G <sub>max.</sub>	H	DRVS	MXC	WT
mm	mm	mm	mm	mm	mm	kN	kg
80	148	73	157	81	12	25	5,6

### Klemmengids

Maten van de onderzijde	<b>78+79</b>	Maattabellen voor de verschillende bekken	<b>80-83</b>
Systeem-toebehoren	<b>85-90</b>	MNG-/PNG nulpuntspansysteem	<b>134-163</b>
Algemeen toebehoren	<b>164-183</b>		

## Maten van de onderzijde van ZSG 4

Basisbreedte 80 mm  
en lengte 130 mm

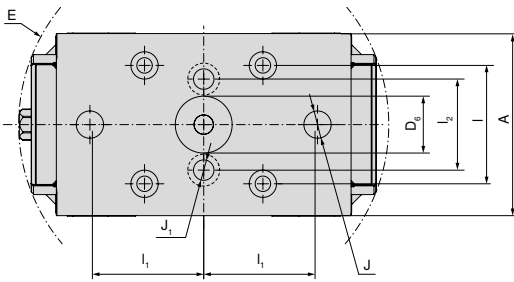

A	D <sub>6 H6</sub>	E	I <sub>1 ±0.015</sub>	I <sub>1 ±0.015</sub>	I <sub>2</sub>	J H <sub>7</sub>	J <sub>1</sub>
mm	mm	mm	mm	mm	mm	mm	mm
80	25	163	52	50	40	12	9

Basisbreedte 80 mm  
en lengte 190 mm

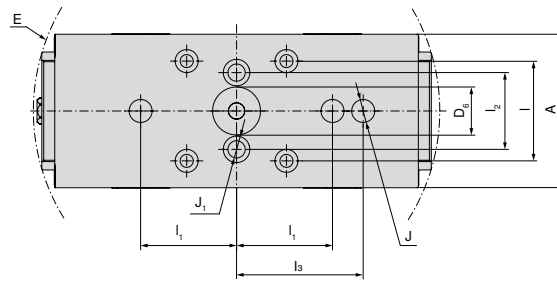

A	D <sub>6 H6</sub>	E	I <sub>1 ±0.015</sub>	I <sub>1 ±0.015</sub>	I <sub>2</sub>	I <sub>3 ±0.015</sub>	J H <sub>7</sub>	J <sub>1</sub>
mm	mm	mm	mm	mm	mm	mm	mm	mm
80	25	213	52	50	40	66	12	9

Basisbreedte 125 mm  
en lengte 160 mm

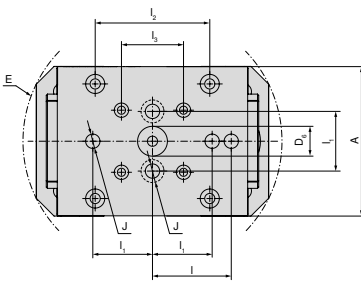

A	D <sub>6 H6</sub>	E	I <sub>1 ±0.015</sub>	I <sub>1 ±0.015</sub>	I <sub>2</sub>	I <sub>3 ±0.015</sub>	J H <sub>7</sub>
mm	mm	mm	mm	mm	mm	mm	mm
125	25	218	66	50	96	52	12

Basisbreedte 125 mm  
en lengte 235 mm

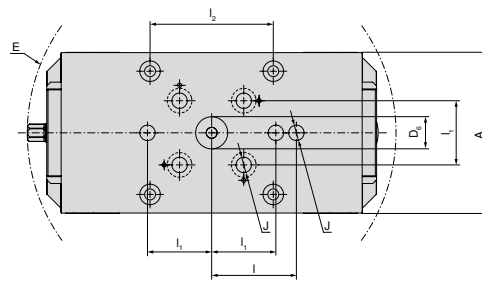

A	D <sub>6 H6</sub>	E	I <sub>1 ±0.015</sub>	I <sub>1 ±0.015</sub>	I <sub>2</sub>	J H <sub>7</sub>
mm	mm	mm	mm	mm	mm	mm
125	25	288	66	50	96	12

Basisbreedte 125 mm  
en lengte 300 mm

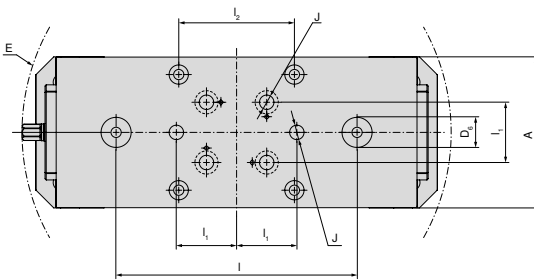

A	D <sub>6 H6</sub>	E	I <sub>1 ±0.015</sub>	I <sub>1 ±0.015</sub>	I <sub>2</sub>	J H <sub>7</sub>
mm	mm	mm	mm	mm	mm	mm
125	25	357	200	50	96	12

## Maten van de onderzijde van ZSG 4

Basisbreedte 160 mm  
en lengte 280 mm

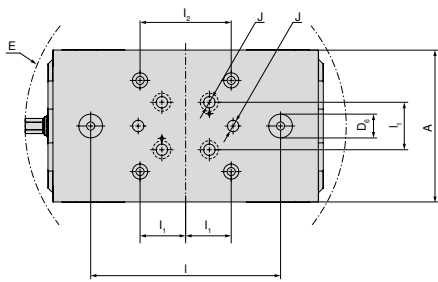

A	D <sub>6</sub> H <sub>6</sub>	E	I <sub>1</sub> ±0,015	I <sub>1</sub> ±0,015	I <sub>2</sub>	J H <sub>7</sub>
mm	mm	mm	mm	mm	mm	mm
160	25	339	200	50	96	12

Basisbreedte 160 mm  
en lengte 480 mm

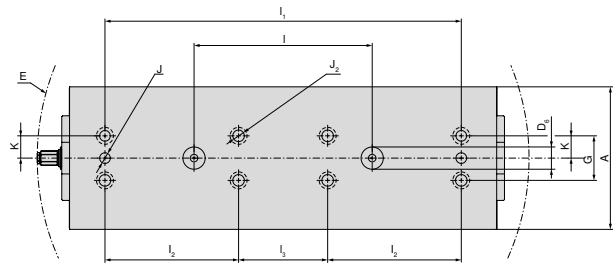

A	D <sub>6</sub> H <sub>6</sub>	E	I <sub>1</sub> ±0,015	I <sub>1</sub> ±0,015	I <sub>2</sub>	I <sub>3</sub> ±0,015	J H <sub>7</sub>	J <sub>2</sub> F <sub>7</sub>	K ±0,02	G
mm	mm	mm	mm	mm	mm	mm	mm	mm	mm	mm
160	25	553	200	400	150	100	12	12	25	50

## ZSG 4 maattabellen voor de verschillende bekken

met combi-bekken

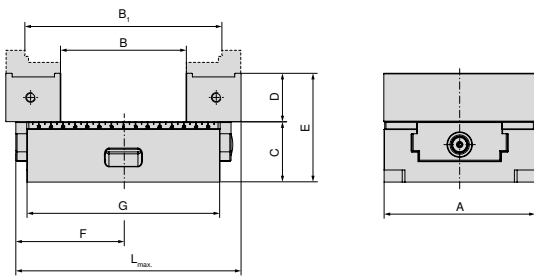

A mm	B mm	B <sub>1</sub> mm	C mm	D mm	E mm	F mm	G mm	L <sub>max</sub> mm	Artikel-nr. Systeembekken
125	23 - 103	82 - 161	50	40	90	111,5	160	208	2 x <b>80 878 530</b>
125	23 - 165	82 - 223	50	40	90	143,5	235	272	2 x <b>80 878 530</b>
125	23 - 241	82 - 300	50	40	90	181	300	348	2 x <b>80 878 530</b>

met pendelbekken en adapterplaten

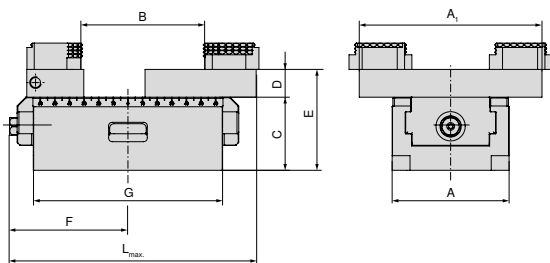

A mm	A <sub>1</sub> mm	B mm	C mm	D mm	E mm	F mm	G mm	L <sub>max</sub> mm	Artikel-nr. Systeembekken
80	125	3 - 84	50	28	78	81	130	157	<b>80 878 890 + 80 878 870</b>
80	125	3 - 145	50	28	78	104	190	206	<b>80 878 890 + 80 878 870</b>
125	180	7 - 126	50	22	90	111,5	160	212	<b>80 878 590 + 80 878 570</b>
125	180	7 - 207	50	22	90	143,5	235	272	<b>80 878 590 + 80 878 570</b>
125	180	7 - 250	50	22	90	181	300	352	<b>80 878 590 + 80 878 570</b>
160	256	16 - 292	70	22	110	170	280	315	<b>80 878 690 + 80 878 670</b>
160	256	16 - 406	70	22	110	276	480	524	<b>80 878 690 + 80 878 670</b>

met aluminium opzetbekken

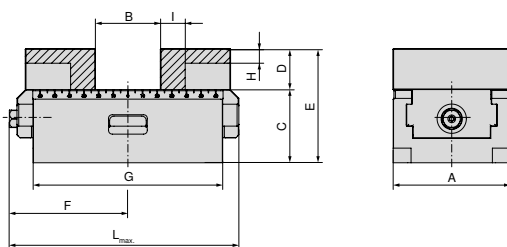

A mm	B mm	C mm	D mm	E mm	F mm	G mm	H mm	I mm	L <sub>max</sub> mm	Artikel-nr. Systeembekken
80	0 - 44	50	28	78	81	130	10	17	157	2 x <b>80 878 850</b>
80	0 - 108	50	28	78	104	190	10	17	206	2 x <b>80 878 850</b>
125	0 - 58	50	40	90	111,5	160	17	27	208	2 x <b>80 878 550</b>
125	0 - 133	50	40	90	143,5	235	17	27	272	2 x <b>80 878 550</b>
125	0 - 198	50	40	90	181	300	17	27	348	2 x <b>80 878 550</b>
160	0 - 123	70	50	120	170	280	26	25	315	2 x <b>80 878 305</b>
160	10 - 336	70	50	120	276	480	26	25	524	2 x <b>80 878 305</b>

## ZSG 4 maattabellen voor de verschillende bekken

met 5-As bekken

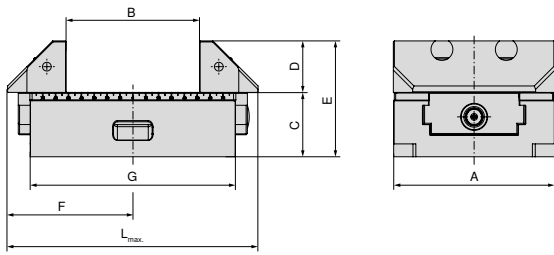

A mm	B mm	C mm	D mm	E mm	F mm	G mm	L <sub>max.</sub> mm	Artikel-nr. Systeembekken
125	22 - 102	50	40	90	115,5	160	208	2 x <b>80 878 625</b>
125	22 - 165	50	40	90	143,5	235	272	2 x <b>80 878 625</b>
125	22 - 242	50	40	90	181	300	348	2 x <b>80 878 625</b>
160	15 - 140	70	50	120	170	280	315	2 x <b>80 878 660</b>
160	28 - 354	70	50	120	276	480	524	2 x <b>80 878 660</b>

met 5-As gripbekken 3 mm, breedte 65 mm

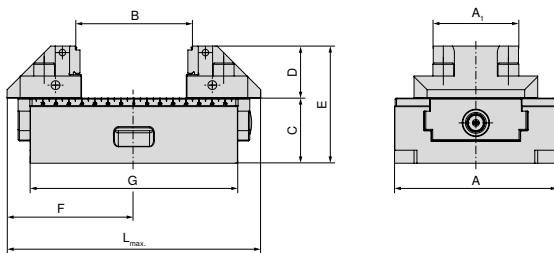

A mm	A <sub>1</sub> mm	B mm	C mm	D mm	E mm	F mm	G mm	L <sub>max.</sub> mm	Artikel-nr. Systeembekken
125	65	8 - 87	50	40	90	115,5	160	208	2 x <b>80 878 665</b>
125	65	8 - 162	50	40	90	143,5	235	272	2 x <b>80 878 665</b>
125	65	8 - 227	50	40	90	181	300	348	2 x <b>80 878 665</b>

met gripbekken 3 mm, breedte 65 mm

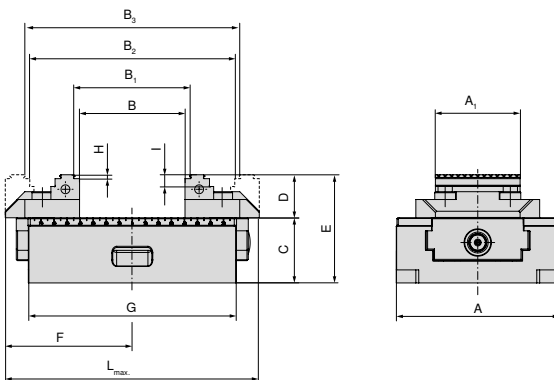

A mm	A <sub>1</sub> mm	B mm	B <sub>1</sub> mm	B <sub>2</sub> mm	B <sub>3</sub> mm	C mm	D mm	E mm	F mm	G mm	H mm	I mm	L <sub>max.</sub> mm	Artikel-nr. Systeembekken
125	65	0 - 80	8 - 87	77 - 156	84 - 163	50	33	83	111,5	160	3	9	208	2 x <b>80 878 51900</b>
125	65	0 - 142	8 - 149	77 - 218	84 - 225	50	33	83	143,5	235	3	9	272	2 x <b>80 878 51900</b>
125	65	0 - 220	8 - 227	77 - 296	84 - 303	50	33	83	181	300	3	9	348	2 x <b>80 878 51900</b>



## ZSG 4 maattabellen voor de verschillende bekken

met gripbekken 3 mm

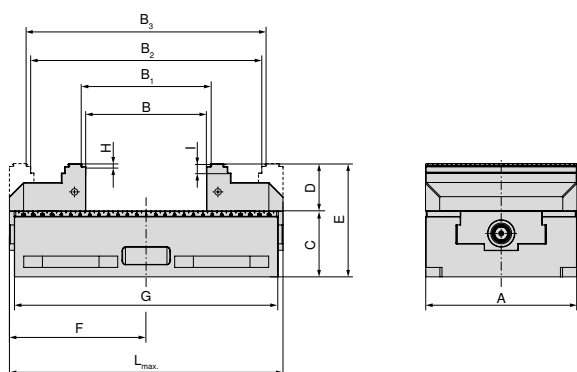

A mm	B mm	B <sub>1</sub> mm	B <sub>2</sub> mm	B <sub>3</sub> mm	C mm	D mm	E mm	F mm	G mm	H mm	I mm	L <sub>max.</sub> mm	Artikel-nr. Systeembekken
160	0 - 127	8 - 134	118 - 244	125 - 251	70	50	120	170	280	3	10	315	2 x <b>80 878 610</b>
160	15 - 341	22 - 348	132 - 458	139 - 465	70	50	120	276	480	3	10	524	2 x <b>80 878 610</b>

met gripbekken 3 mm, hoogte 40 mm

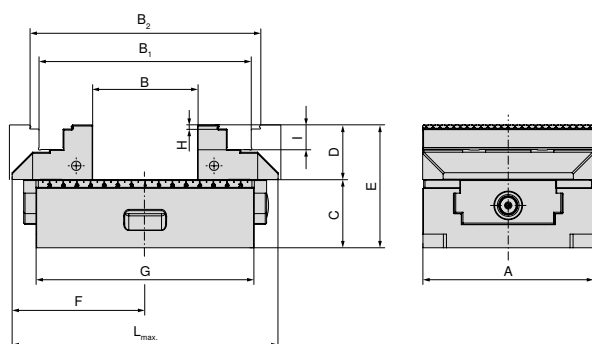

A mm	B mm	B <sub>1</sub> mm	B <sub>2</sub> mm	C mm	D mm	E mm	F mm	G mm	H mm	I mm	L <sub>max.</sub> mm	Artikel-nr. Systeembekken
125	0 - 75	75 - 154	88 - 166	50	40	90	111,5	160	3	9	208	2 x <b>80 878 520</b>
125	0 - 138	75 - 217	88 - 229	50	40	90	143,5	235	3	9	272	2 x <b>80 878 520</b>
125	0 - 215	75 - 294	88 - 306	50	40	90	181	300	3	9	348	2 x <b>80 878 520</b>

met 6-voudig bekkensysteem voor bekbreedte 125 mm

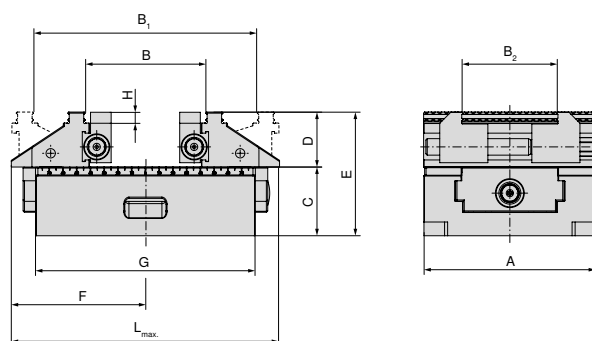

A mm	B mm	B <sub>1</sub> mm	B <sub>2</sub> mm	C mm	D mm	E mm	F mm	G mm	H mm	L <sub>max.</sub> mm	Artikel-nr. Systeembekken
125	39 - 86	83 - 161	37 - 101	50	40	90	111,5	160	8	209	<b>80 878 525</b>
125	39 - 149	83 - 224	37 - 101	50	40	90	143,5	235	8	272	<b>80 878 525</b>
125	39 - 226	83 - 301	37 - 101	50	40	90	181	300	8	349	<b>80 878 525</b>

## ZSG 4 maattabellen voor de verschillende bekken

met met grip tussenbek 3 mm (hoogte 28 mm / 33 mm) voor bekbreedte 125 mm

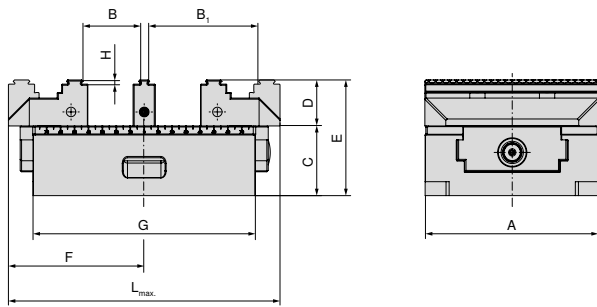

A mm	B mm	B <sub>1</sub> mm	C mm	D mm	E mm	F mm	G mm	H mm	L <sub>max.</sub> mm	Artikel-nr. Systeembekken
80	8 - 28	37 - 57	50	28	78	81	130	3	157	2 x 80 878 810 + 80 878 31200
80	14 - 22	31 - 51	50	28	78	81	130	3	157	2 x 80 878 810 + 80 878 33400
80	8 - 58	37 - 87	50	28	78	104	190	3	206	2 x 80 878 810 + 80 878 31200
80	14 - 52	31 - 81	50	28	78	104	190	3	206	2 x 80 878 810 + 80 878 33400
125	9 - 40	47 - 78	50	33	83	111,5	160	3	208	2 x 80 878 510 + 80 878 31300
125	15 - 34	41 - 72	50	33	83	111,5	160	3	208	2 x 80 878 510 + 80 878 33500
125	9 - 72	47 - 110	50	33	83	143,5	235	3	272	2 x 80 878 510 + 80 878 31300
125	15 - 66	41 - 104	50	33	83	143,5	235	3	272	2 x 80 878 510 + 80 878 33500
125	9 - 110	47 - 148	50	33	83	181	300	3	348	2 x 80 878 510 + 80 878 31300
125	15 - 104	41 - 142	50	33	83	181	300	3	348	2 x 80 878 510 + 80 878 33500

met prismabek, verplaatsbaar – horizontale en verticale prisma

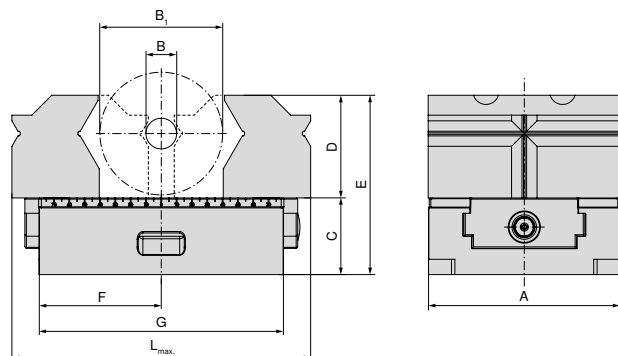

A mm	B mm	B <sub>1</sub> mm	C mm	D mm	E mm	F mm	G mm	L <sub>max.</sub> mm	Artikel-nr. Systeembekken
80	10 - 28	20 - 60	50	52	102	81	130	157	2 x 80 878 31800
80	10 - 28	20 - 60	50	52	102	104	190	206	2 x 80 878 31800
125	10 - 28	26 - 80	50	67	117	111,5	160	200	2 x 80 878 31900
125	10 - 28	26 - 80	50	67	117	143,5	235	272	2 x 80 878 31900
125	10 - 28	26 - 80	50	67	117	181	300	348	2 x 80 878 31900

## ZSG 4 maattabellen voor de verschillende bekken

met prismabek, verplaatsbaar – horizontale prisma

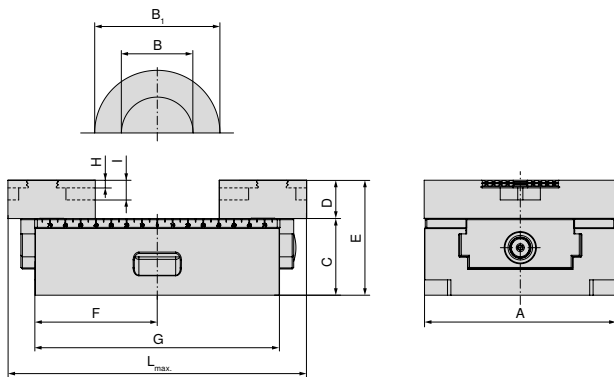

A mm	B mm	B <sub>1</sub> mm	C mm	D mm	E mm	F mm	G mm	H mm	I mm	L <sub>max</sub> mm	Artikel-nr. Systeembekken
80	8 - 55	15 - 76	50	25	75	81	130	5	13	157	2 x <b>80 878 34000</b>
80	8 - 55	15 - 76	50	25	75	104	190	5	13	206	2 x <b>80 878 34000</b>
125	14 - 102	25 - 112	50	25	75	111,5	160	5	13	200	2 x <b>80 878 34100</b>
125	14 - 124	25 - 165	50	25	75	143,5	235	5	13	272	2 x <b>80 878 34100</b>
125	14 - 124	25 - 165	50	25	75	181	300	5	13	348	2 x <b>80 878 34100</b>
160	22 - 158	32 - 170	70	30	100	145	280	5	13	290	2 x <b>80 878 34200</b>
160	22 - 158	32 - 170	70	30	100	273	480	5	13	521	2 x <b>80 878 34200</b>

# Overzicht systeembekken

## 5-As bek, los

▲ prijs per stuk

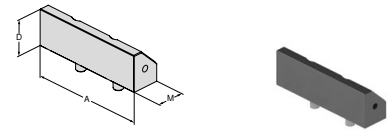

voor basisbreedte	A	A <sub>1</sub>	D	D <sub>1</sub>	D <sub>2</sub>	E	M	M <sub>1</sub>	M <sub>2</sub>	EUR	Y4	NCG	H5G / -S / -Z	X5G-Z / -S	ESG 4	ESG 5	HDG 2	ZSG 4	ZSG mini	DSG 4	Verzo	HSG	
125	125		40				45,5			225,00									●				
160	160		50				73			277,00									●				

## Gripbek 3 mm, breedte 65 mm, los

▲ prijs per stuk

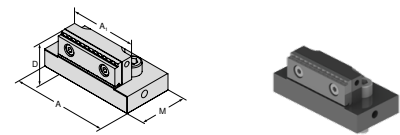

voor basisbreedte	A	A <sub>1</sub>	D	D <sub>1</sub>	D <sub>2</sub>	E	M	M <sub>1</sub>	M <sub>2</sub>	EUR	Y4	NCG	H5G / -S / -Z	X5G-Z / -S	ESG 4	ESG 5	HDG 2	ZSG 4	ZSG mini	DSG 4	Verzo	HSG	
125	95	65,5	40				57			260,00									●				

## Gripbek 3 mm, breedte 65 mm, los

▲ dubbelzijdige getrapte gripbek

▲ prijs per stuk

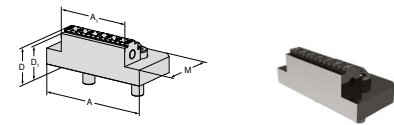

voor basisbreedte	A	A <sub>1</sub>	D	D <sub>1</sub>	D <sub>2</sub>	E	M	M <sub>1</sub>	M <sub>2</sub>	EUR	Y4	NCG	H5G / -S / -Z	X5G-Z / -S	ESG 4	ESG 5	HDG 2	ZSG 4	ZSG mini	DSG 4	Verzo	HSG	
125	95	65	33	30			57			196,00									●				

## Gripbek 3 mm, breedte 40 mm, los

▲ prijs per stuk

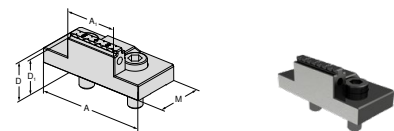

voor basisbreedte	A	A <sub>1</sub>	D	D <sub>1</sub>	D <sub>2</sub>	E	M	M <sub>1</sub>	M <sub>2</sub>	EUR	Y4	NCG	H5G / -S / -Z	X5G-Z / -S	ESG 4	ESG 5	HDG 2	ZSG 4	ZSG mini	DSG 4	Verzo	HSG	
80	80	40	28	25			40			180,00					●			●					

## Gripbek 3 mm, hoogte 40 mm, los

▲ prijs per stuk

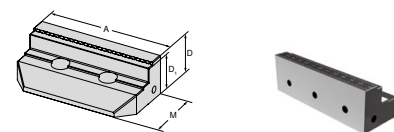

voor basisbreedte	A	A <sub>1</sub>	D	D <sub>1</sub>	D <sub>2</sub>	E	M	M <sub>1</sub>	M <sub>2</sub>	EUR	Y4	NCG	H5G / -S / -Z	X5G-Z / -S	ESG 4	ESG 5	HDG 2	ZSG 4	ZSG mini	DSG 4	Verzo	HSG	
125	125		40	37			59			282,00									●				

## Overzicht systeembekken

### Gripbek 3 mm, los

▲ prijs per stuk

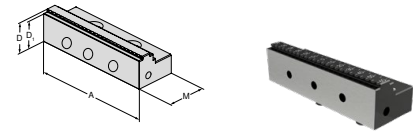

voor basisbreedte	A	A <sub>1</sub>	D	D <sub>1</sub>	D <sub>2</sub>	E	M	M <sub>1</sub>	M <sub>2</sub>	EUR	Y4	NCG	H5G / -S / -Z	X5G-Z / -S	ESG 4	ESG 5	HDC 2	ZSG 4	ZSG mini	DSG 4	Versto	HSG		
80	80		28	25			40			135,00	80 878 810				●	●		●		●				
125	125		33	30			57			151,00	80 878 510				●	●		●						
160	160		50	47			81			404,00	80 878 610				●	●		●						

### Gripbek 5 mm, los

▲ prijs per stuk

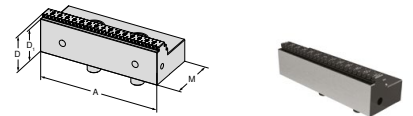

voor basisbreedte	A	A <sub>1</sub>	D	D <sub>1</sub>	D <sub>2</sub>	E	M	M <sub>1</sub>	M <sub>2</sub>	EUR	Y4	NCG	H5G / -S / -Z	X5G-Z / -S	ESG 4	ESG 5	HDC 2	ZSG 4	ZSG mini	DSG 4	Versto	HSG		
80	80		28	23			41			160,00	80 878 81400				●			●		●				
125	125		33	28			57			177,00	80 878 51400				●			●						
160	160		50	45			81			404,00	80 878 34300				●			●						

### Gripbek voor aluminium en kunststof

▲ prijs per stuk

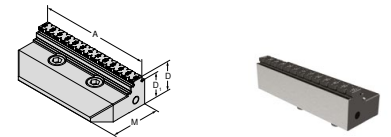

voor basisbreedte	A	A <sub>1</sub>	D	D <sub>1</sub>	D <sub>2</sub>	E	M	M <sub>1</sub>	M <sub>2</sub>	EUR	Y4	NCG	H5G / -S / -Z	X5G-Z / -S	ESG 4	ESG 5	HDC 2	ZSG 4	ZSG mini	DSG 4	Versto	HSG		
80	80		28	23			40			191,00	80 878 81500							●						
125	125		33	28			57			210,00	80 878 51500							●						

### Gripbek met Prägeprofil, losse bek

▲ prijs per stuk

▲ passend op LANG Prägeprofil

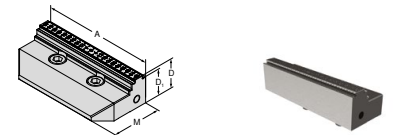

voor basisbreedte	A	A <sub>1</sub>	D	D <sub>1</sub>	D <sub>2</sub>	E	M	M <sub>1</sub>	M <sub>2</sub>	EUR	Y4	NCG	H5G / -S / -Z	X5G-Z / -S	ESG 4	ESG 5	HDC 2	ZSG 4	ZSG mini	DSG 4	Versto	HSG		
80	80		28	25			40			170,00	80 878 81800							●						
125	125		33	30			57			233,00	80 878 51800							●						

## Overzicht systeembekken

### Carbide gripbek 3 mm, los

▲ prijs per stuk

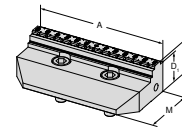

voor basisbreedte	A	A <sub>1</sub>	D	D <sub>1</sub>	D <sub>2</sub>	E	M	M <sub>1</sub>	M <sub>2</sub>	EUR	Y4	NCG	H5G / -S / -Z	X5G-Z / -S	ESG 4	ESG 5	HDG 2	ZSG 4	ZSG mini	DSG 4	Verso	HSG	
80	80		28	25			40			242,00	80 878 81600								●				
125	125		33	30			57			342,00	80 878 51600								●				
160	160		50	47			81			537,00	80 878 31700								●				

### Carbide gripbek 5 mm, los

▲ prijs per stuk

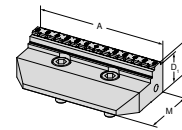

voor basisbreedte	A	A <sub>1</sub>	D	D <sub>1</sub>	D <sub>2</sub>	E	M	M <sub>1</sub>	M <sub>2</sub>	EUR	Y4	NCG	H5G / -S / -Z	X5G-Z / -S	ESG 4	ESG 5	HDG 2	ZSG 4	ZSG mini	DSG 4	Verso	HSG	
80	80		28	23			40			242,00	80 878 81700								●				
125	125		33	28			57			342,00	80 878 51700								●				

### Carbide gripbek 3 mm, breedte 40 mm, los

▲ prijs per stuk

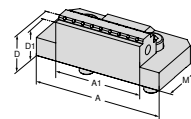

voor basisbreedte	A	A <sub>1</sub>	D	D <sub>1</sub>	D <sub>2</sub>	E	M	M <sub>1</sub>	M <sub>2</sub>	EUR	Y4	NCG	H5G / -S / -Z	X5G-Z / -S	ESG 4	ESG 5	HDG 2	ZSG 4	ZSG mini	DSG 4	Verso	HSG	
80	80	40	28	25			40			234,00	80 878 33200								●				

### Carbide gripbek 3 mm, breedte 65 mm, los

▲ prijs per stuk

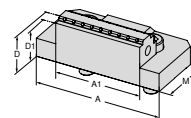

voor basisbreedte	A	A <sub>1</sub>	D	D <sub>1</sub>	D <sub>2</sub>	E	M	M <sub>1</sub>	M <sub>2</sub>	EUR	Y4	NCG	H5G / -S / -Z	X5G-Z / -S	ESG 4	ESG 5	HDG 2	ZSG 4	ZSG mini	DSG 4	Verso	HSG	
125	125	65	33	30			57			324,00	80 878 33300								●				

### Losse bek, glad

▲ prijs per stuk

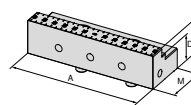

voor basisbreedte	A	A <sub>1</sub>	D	D <sub>1</sub>	D <sub>2</sub>	E	M	M <sub>1</sub>	M <sub>2</sub>	EUR	Y4	NCG	H5G / -S / -Z	X5G-Z / -S	ESG 4	ESG 5	HDG 2	ZSG 4	ZSG mini	DSG 4	Verso	HSG	
80	80		28	20			40			195,00	80 878 34700					●		●					
125	125		33	25			57			378,00	80 878 34600					●		●					

## Overzicht systeembekken

### Getrapte losse bek, glad

▲ prijs per stuk

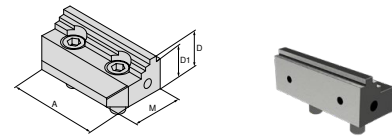

voor basisbreedte	A	A <sub>1</sub>	D	D <sub>1</sub>	D <sub>2</sub>	E	M	M <sub>1</sub>	M <sub>2</sub>	EUR	Y4	NCG	H5G / -S / -Z	X5G-Z / -S	ESG 4	ESG 5	HDG 2	ZSG 4	ZSG mini	DSG 4	Verso	HSG	
80	80		28	24			40			247,00	80 878 34400								●				
125	125		33	27			57			347,00	80 878 34500								●				

### Tussenbek, 3 mm grip, dun

▲ prijs per stuk

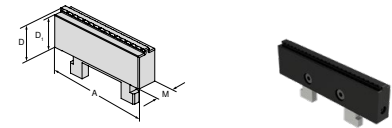

voor basisbreedte	A	A <sub>1</sub>	D	D <sub>1</sub>	D <sub>2</sub>	E	M	M <sub>1</sub>	M <sub>2</sub>	EUR	Y4	NCG	H5G / -S / -Z	X5G-Z / -S	ESG 4	ESG 5	HDG 2	ZSG 4	ZSG mini	DSG 4	Verso	HSG	
80	80		28	25			16			110,00	80 878 31200								●				
125	125		33	30			16			155,00	80 878 31300								●				

### Tussenbek, 3 mm grip, dik

▲ prijs per stuk

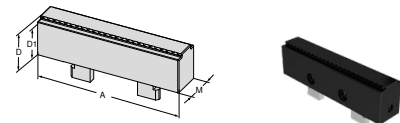

voor basisbreedte	A	A <sub>1</sub>	D	D <sub>1</sub>	D <sub>2</sub>	E	M	M <sub>1</sub>	M <sub>2</sub>	EUR	Y4	NCG	H5G / -S / -Z	X5G-Z / -S	ESG 4	ESG 5	HDG 2	ZSG 4	ZSG mini	DSG 4	Verso	HSG	
80	80		28	25			24			110,00	80 878 33400								●				
125	125		33	30			26			155,00	80 878 33500								●				

### Prismabek, verplaatsbaar

▲ met horizontaal en verticaal prisma

▲ prijs per stuk

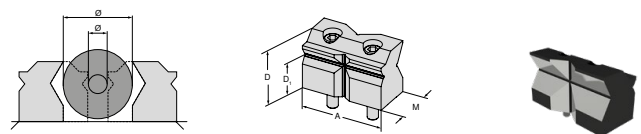

∅ voor spandiameter	A	A <sub>1</sub>	D	D <sub>1</sub>	D <sub>2</sub>	E	M	M <sub>1</sub>	M <sub>2</sub>	EUR	Y4	NCG	H5G / -S / -Z	X5G-Z / -S	ESG 4	ESG 5	HDG 2	ZSG 4	ZSG mini	DSG 4	Verso	HSG	
10 - 60	80		52	32			38,5			319,00	80 878 31800								●				
10 - 80	125		67	42			57			486,00	80 878 31900								●				

## Overzicht systeembekken

### Prismabek, verplaatsbaar

- ▲ met horizontale prisma
- ▲ prijs per stuk

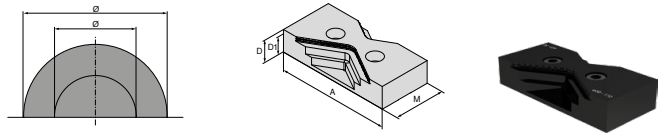

∅ voor spandiameter	A	A <sub>1</sub>	D	D <sub>1</sub>	D <sub>2</sub>	E	M	M <sub>1</sub>	M <sub>2</sub>	EUR	Y4	NCG	H5G / -S / -Z	X5G-Z / -S	ESG 4	ESG 5	HDG 2	ZSG 4	ZSG mini	DSG 4	Verso	HSG	
15 - 75	80		25	20			40			171,00	80 878 34000								●				
25 - 110	125		25	20			57			220,00	80 878 34100								●				
30 - 170	160		30	25			81			285,00	80 878 34200								●				

### Combi-bek, verplaatsbaar

- ▲ prijs per stuk

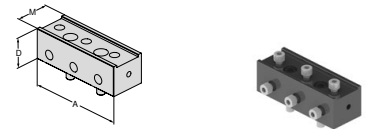

voor basisbreedte	A	A <sub>1</sub>	D	D <sub>1</sub>	D <sub>2</sub>	E	M	M <sub>1</sub>	M <sub>2</sub>	EUR	Y4	NCG	H5G / -S / -Z	X5G-Z / -S	ESG 4	ESG 5	HDG 2	ZSG 4	ZSG mini	DSG 4	Verso	HSG	
125	125		40				45,5			173,00	80 878 530								●				

### Gripbek VS

- ▲ prijs per stuk
- ▲ VS = vergroot spanbereik

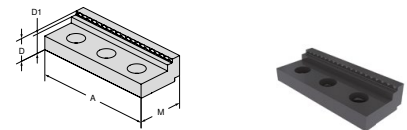

voor basisbreedte	A	A <sub>1</sub>	D	D <sub>1</sub>	D <sub>2</sub>	E	M	M <sub>1</sub>	M <sub>2</sub>	EUR	Y4	NCG	H5G / -S / -Z	X5G-Z / -S	ESG 4	ESG 5	HDG 2	ZSG 4	ZSG mini	DSG 4	Verso	HSG	
125	125		22	17			45			99,30	80 892 245								●				

### Gladde bek VS, WC-gecoat

- ▲ vergroot spanbereik voor de finishbewerking en 2<sup>e</sup> zijde
- ▲ prijs per stuk

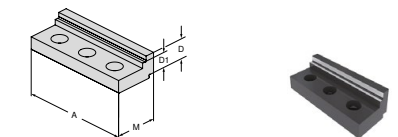

voor basisbreedte	A	A <sub>1</sub>	D	D <sub>1</sub>	D <sub>2</sub>	E	M	M <sub>1</sub>	M <sub>2</sub>	EUR	Y4	NCG	H5G / -S / -Z	X5G-Z / -S	ESG 4	ESG 5	HDG 2	ZSG 4	ZSG mini	DSG 4	Verso	HSG	
125	125		19	14			45			239,00	80 892 240								●				

### Zachte opzetbek (aluminium)

- ▲ voor het maken van vormbekken
- ▲ prijs per stuk

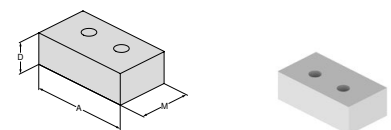

voor basisbreedte	A	A <sub>1</sub>	D	D <sub>1</sub>	D <sub>2</sub>	E	M	M <sub>1</sub>	M <sub>2</sub>	EUR	Y4	NCG	H5G / -S / -Z	X5G-Z / -S	ESG 4	ESG 5	HDG 2	ZSG 4	ZSG mini	DSG 4	Verso	HSG	
80	80		28				48			86,40	80 878 850				●	●			●				
125	125		40				68			98,30	80 878 550				●	●			●				
160	160		50				85			124,00	80 878 305				●	●			●				



## Overzicht systeembekken

### Zachte bek, staal, los

- ▲ materiaal: 16MnCr5
- ▲ voor het maken van vormbekken
- ▲ prijs per stuk

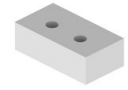
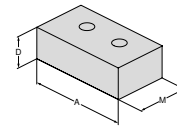

voor basisbreedte	A	A <sub>1</sub>	D	D <sub>1</sub>	D <sub>2</sub>	E	M	M <sub>1</sub>	M <sub>2</sub>	EUR	Y4	NCG	H5G / -S / -Z	X5G-Z / -S	ESG 4	ESG 5	HDG 2	ZSG 4	ZSG mini	DSG 4	Versto	HSG	
80	80		28				48			89,10	80 878 32000				●	●		●					
125	125		40				68			112,00	80 878 32100				●	●		●					

### Pendelbek, los

- ▲ voor opname van 6-voudige bekken
- ▲ prijs per stuk

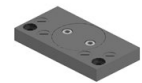
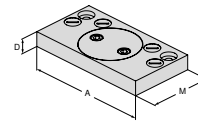

voor basisbreedte	A	A <sub>1</sub>	D	D <sub>1</sub>	D <sub>2</sub>	E	M	M <sub>1</sub>	M <sub>2</sub>	EUR	Y4	NCG	H5G / -S / -Z	X5G-Z / -S	ESG 4	ESG 5	HDG 2	ZSG 4	ZSG mini	DSG 4	Versto	HSG	
80	125		19				76			409,00	80 878 870				●			●		●			
125	180		22				95			426,00	80 878 570				●			●		●			
160	256		22				170			726,00	80 878 670				●			●		●			

### Adapterbek

- ▲ voor opname van 6-voudige bekken
- ▲ prijs per stuk

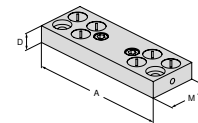

voor basisbreedte	A	A <sub>1</sub>	D	D <sub>1</sub>	D <sub>2</sub>	E	M	M <sub>1</sub>	M <sub>2</sub>	EUR	Y4	NCG	H5G / -S / -Z	X5G-Z / -S	ESG 4	ESG 5	HDG 2	ZSG 4	ZSG mini	DSG 4	Versto	HSG	
80	125		19				39			290,00	80 878 890							●					
125	180		22				62			346,00	80 878 590							●					
160	256		22				125			484,00	80 878 690							●					

### 6-voudige bek

- ▲ 1 = glad, wolframcarbide gecoat
- ▲ 2 = grip met trap 3 mm
- ▲ 3 = grip met trap 8 mm
- ▲ 4 = grip met trap 18 mm
- ▲ 5 = grip met trap 8 mm
- ▲ 6 = grip rond
- ▲ M<sub>max</sub> = 60 Nm
- ▲ incl. bevestigingsbout

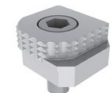
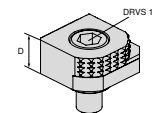

voor basisbreedte	A	A <sub>1</sub>	D	D <sub>1</sub>	D <sub>2</sub>	E	M	M <sub>1</sub>	M <sub>2</sub>	EUR	Y4	NCG	H5G / -S / -Z	X5G-Z / -S	ESG 4	ESG 5	HDG 2	ZSG 4	ZSG mini	DSG 4	Versto	HSG	
			18							80,60	80 892 246	●	●	●	●	●	●	●	●	●	●	●	●

## Overzicht systeembekken

### 6-voudige bek

- ▲ 1 = glad
- ▲ 2 = carbide grip
- ▲ 3 = carbide grip met trap 3 mm
- ▲ 4 = carbide grip met trap 8 mm
- ▲ 5 = carbide grip rond met trap 8 mm
- ▲ 6 = carbide grip rond
- ▲ incl. bevestigingsbout

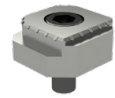
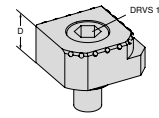

voor basisbreedte	A	A <sub>1</sub>	D	D <sub>1</sub>	D <sub>2</sub>	E	M	M <sub>1</sub>	M <sub>2</sub>	EUR	Y4	NCG	H5G / -S / -Z	X5G-Z / -S	ESG 4	ESG 5	H5G 2	ZSG 4	ZSG mini	DSG 4	Verso	H5G
			18							117,00	80 890 35300	●	●	●	●			●		●	●	

### 6-Voudig bekkensysteem voor bekbreedte 125 mm

**leveromvang:**

2 systeembekken met 2 paar dwarsbekken in T-gleufuitvoering incl. bevestigingsbouten

**ZSG  
4**

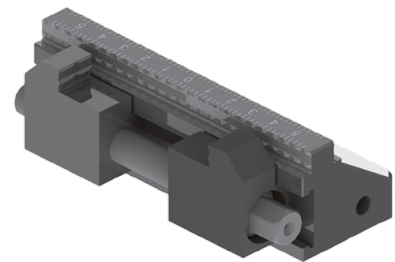
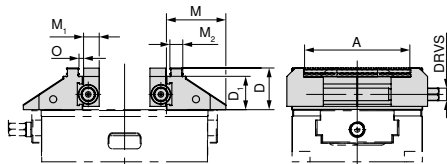

voor breedte	A	D	D <sub>1</sub>	M	M <sub>1</sub>	M <sub>2</sub>	O	DRVS	WT	80 878 ...	
mm	mm	mm	mm	mm	mm	mm	mm	mm	kg	EUR	
125	37 - 101	40	32	57	15	12,4	3,3	12	3,8	Y4	
										1.720,00	525

## ZSG mini



## Centrumspanner voor kleine delen

De ZSG-mini is een mechanische klem met hoge spankracht en snelwissel bekken. Perfect geschikt voor het opspannen van ruwdelen, bewerkte werkstukken, meervoudig spannen en automatisering.

## Uw voordelen:

- ▲ bekken snel verwisselbaar zonder gereedschap
- ▲ compact en nauwkeurig
- ▲ beste toegankelijkheid van alle zijden
- ▲ bekbreedte verwisselbaar (45 en 70 mm)
- ▲ hoge spankracht en groot spanbereik
- ▲ spansysteem voor automatisering
- ▲ RVS en geharde basis



## Opspannen / uitlijnen:



Montage d.m.v. twee M6 schroeven vanaf de bovenkant door de basis.



Montage d.m.v. twee M6 schroeven vanaf de bovenkant door de basis. Uitlijning kan door gebruik van  $\text{Ø } 12^{\text{H7}}$  precisie boringen.



Beide uitvoeringen zijn uitgerust met boringen voor het LANG Quick-Point 52 x 52 nulpuntsysteem.

Spankracht:

Aandraaimoment / Spankracht ZSG-mini

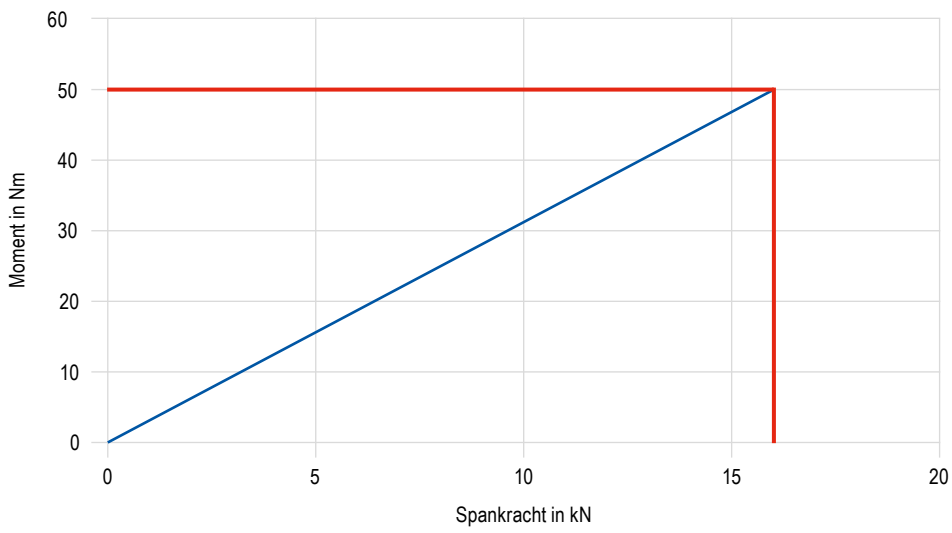

## CentriClamp – ZSG mini

- ▲ Centrumspanner voor kleine delen
- ▲ zonder systeembekken
- ▲ Bekken snel verwisselbaar zonder gereedschap
- ▲ compact en nauwkeurig
- ▲ beste toegankelijkheid van alle zijden
- ▲ Meerdere bekkenbreedtes (45 en 70 mm)
- ▲ Roestvaste en geharde basis

### leveromvang:

ZSG-mini basis met spindel

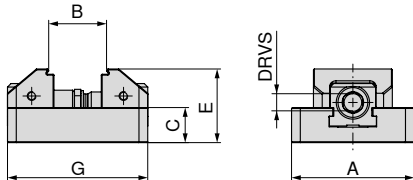

**NEW**

**80 912 ...**

A	B	C	E	G	MXC	DRVS	WT
mm	mm	mm	mm	mm	kN	mm	kg
70	7 - 57	20	42	80	16	11	0,9
70	7 - 77	20	42	100	16	11	1,1

EUR	
Y4	
420,00	07000
476,00	07100

### Klemmengids

Maten van de onderzijde	94	Maattabellen voor de verschillende bekken	95-97
Systeem-toebehoren	98-100	MNG-/PNG nulpuntspansysteem	134-163
Algemeen toebehoren	164-183		

## Maten van de onderzijde van ZSG mini

### Basisbreedte 70 mm

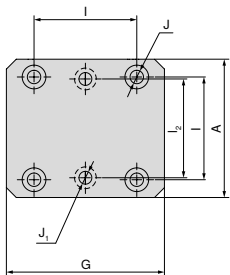

A	J <sub>1</sub>	J <sub>H7</sub>	l <sub>2 ±0.01</sub>	l <sub>±0.01</sub>	G
mm	mm	mm	mm	mm	mm
70	6,5	12	50	52	80
70	6,5	12	50	52	100

## ZSG-mini – Maattabel voor de verschillende bekken

Snelwissel bek, 3 mm gripbek

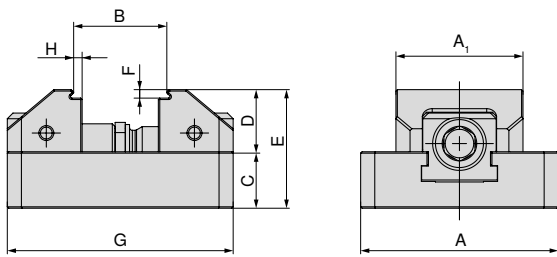

A mm	A <sub>1</sub> mm	B mm	C mm	D mm	E mm	F mm	G mm	H mm	Artikel-nr. Systeembekken
70	45	7 - 33	20	22	42	3	80	3	2 x 80 912 30100
70	70	7 - 33	20	22	42	3	80	3	2 x 80 912 30200
70	45	7 - 53	20	22	42	3	100	3	2 x 80 912 30100
70	70	7 - 53	20	22	42	3	100	3	2 x 80 912 30200

met snelwissel bek, glad 5 mm

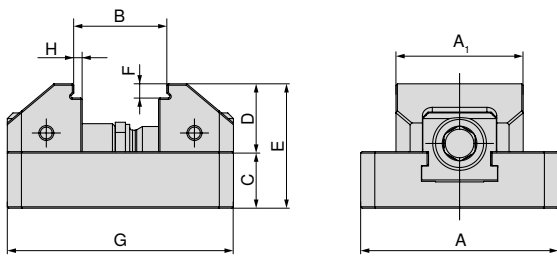

A mm	A <sub>1</sub> mm	B mm	C mm	D mm	E mm	F mm	G mm	H mm	Artikel-nr. Systeembekken
70	45	7 - 33	20	24	44	5	80	3	2 x 80 912 30300
70	70	7 - 33	20	24	44	5	80	3	2 x 80 912 30400
70	45	7 - 53	20	24	44	5	100	3	2 x 80 912 30300
70	70	7 - 53	20	24	44	5	100	3	2 x 80 912 30400

met zachte snelwisselbek (staal)

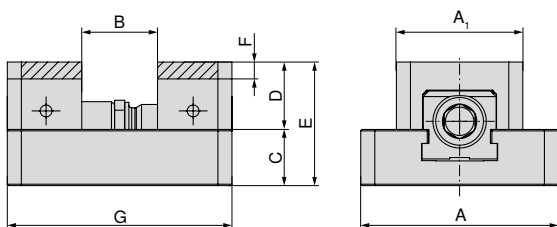

A mm	A <sub>1</sub> mm	B mm	C mm	D mm	E mm	F mm	G mm	Artikel-nr. Systeembekken
70	45	0 - 26	20	24	44	6	80	2 x 80 912 31000
70	70	0 - 26	20	24	44	6	80	2 x 80 912 31100
70	45	0 - 46	20	24	44	6	80	2 x 80 912 31000
70	70	0 - 46	20	24	44	6	80	2 x 80 912 31100

## ZSG-mini – Maattabel voor de verschillende bekken

met Prägeprofil snelwisselbek

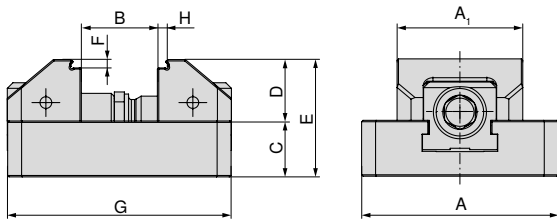

A mm	A <sub>1</sub> mm	B mm	C mm	D mm	E mm	F mm	G mm	H mm	Artikel-nr. Systeembekken
70	45	7 - 32	20	22	44	3	80	3	2 x <b>80 912 31200</b>
70	70	7 - 32	20	22	44	3	80	3	2 x <b>80 912 31300</b>
70	45	7 - 52	20	22	44	3	100	3	2 x <b>80 912 31200</b>
70	70	7 - 52	20	22	44	3	100	3	2 x <b>80 912 31300</b>

met Prägeprofil snelwisselbek, VS

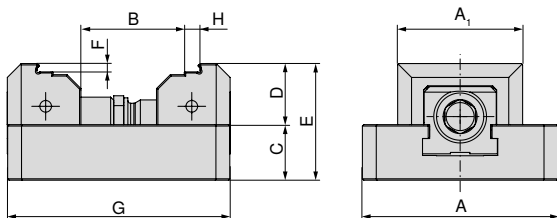

A mm	A <sub>1</sub> mm	B mm	C mm	D mm	E mm	F mm	G mm	H mm	Artikel-nr. Systeembekken
70	45	31 - 56	20	22	44	3	80	5	2 x <b>80 912 31400</b>
70	70	31 - 56	20	22	44	3	80	5	2 x <b>80 912 31500</b>
70	45	31 - 76	20	22	44	3	100	5	2 x <b>80 912 31400</b>
70	70	31 - 76	20	22	44	3	100	5	2 x <b>80 912 31500</b>

## ZSG-mini – Maattabel voor de verschillende bekken

Snelwisselbek VS, 3 mm gripbek

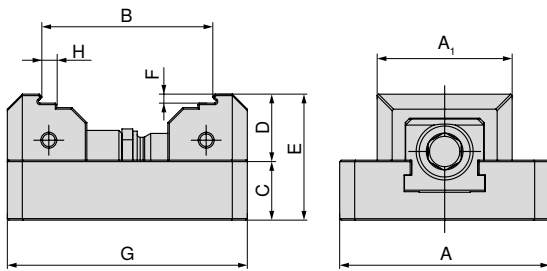

A mm	A <sub>1</sub> mm	B mm	C mm	D mm	E mm	F mm	G mm	H mm	Artikel-nr. Systeembekken
70	45	31 - 57	20	22	42	3	80	5	2 x <b>80 912 30500</b>
70	70	31 - 57	20	22	42	3	80	5	2 x <b>80 912 30600</b>
70	45	31 - 77	20	22	42	3	100	5	2 x <b>80 912 30500</b>
70	70	31 - 77	20	22	42	3	100	5	2 x <b>80 912 30600</b>

met gladde snelwisselbek, 5 mm, VS

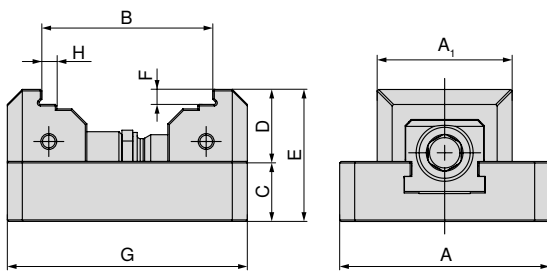

A mm	A <sub>1</sub> mm	B mm	C mm	D mm	E mm	F mm	G mm	H mm	Artikel-nr. Systeembekken
70	45	31 - 56	20	24	44	5	80	5	2 x <b>80 912 30700</b>
70	70	31 - 56	20	24	44	5	80	5	2 x <b>80 912 30800</b>
70	45	31 - 76	20	24	44	5	100	5	2 x <b>80 912 30700</b>
70	70	31 - 76	20	24	44	5	100	5	2 x <b>80 912 30800</b>



## Overzicht systeembekken

### Snelwisselbek 3 mm gripbek

▲ prijs per stuk

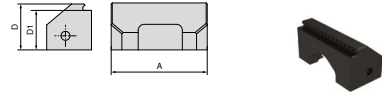

voor basisbreedte	A	A <sub>1</sub>	D	D <sub>1</sub>	D <sub>2</sub>	E	M	M <sub>1</sub>	M <sub>2</sub>	EUR	Y4	NCG	H5G / -S / -Z	X5G-Z / -S	ESG 4	ESG 5	HDG 2	ZSG 4	ZSG mini	DSG 4	Verso	HSG	
70	45		22	19						50,80													
70	70		22	19						66,90										●			

### Snelwisselbek glad 5 mm

▲ prijs per stuk

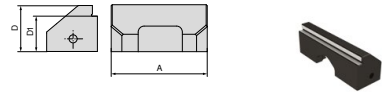

voor basisbreedte	A	A <sub>1</sub>	D	D <sub>1</sub>	D <sub>2</sub>	E	M	M <sub>1</sub>	M <sub>2</sub>	EUR	Y4	NCG	H5G / -S / -Z	X5G-Z / -S	ESG 4	ESG 5	HDG 2	ZSG 4	ZSG mini	DSG 4	Verso	HSG	
70	45		24	19						61,50													
70	70		24	19						77,80										●			

### Snelwisselbek VS, 3 mm gripbek

▲ prijs per stuk

▲ VS = vergroot spanbereik

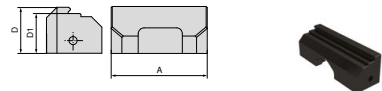

voor basisbreedte	A	A <sub>1</sub>	D	D <sub>1</sub>	D <sub>2</sub>	E	M	M <sub>1</sub>	M <sub>2</sub>	EUR	Y4	NCG	H5G / -S / -Z	X5G-Z / -S	ESG 4	ESG 5	HDG 2	ZSG 4	ZSG mini	DSG 4	Verso	HSG	
70	45		22	19						50,80													
70	70		22	19						66,90										●			

### Snelwisselbek VS, glad 5 mm

▲ prijs per stuk

▲ VS = vergroot spanbereik

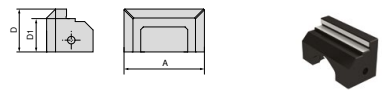

voor basisbreedte	A	A <sub>1</sub>	D	D <sub>1</sub>	D <sub>2</sub>	E	M	M <sub>1</sub>	M <sub>2</sub>	EUR	Y4	NCG	H5G / -S / -Z	X5G-Z / -S	ESG 4	ESG 5	HDG 2	ZSG 4	ZSG mini	DSG 4	Verso	HSG	
70	45		24	19						61,50													
70	70		24	19						77,80										●			

# Overzicht systeembekken

## Zachte snelwisselbek (staal)

- ▲ materiaal: 15NiCr13
- ▲ prijs per stuk

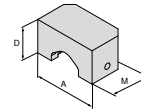

voor basisbreedte	A	A <sub>1</sub>	D	D <sub>1</sub>	D <sub>2</sub>	E	M	M <sub>1</sub>	M <sub>2</sub>	EUR	Y4	NCG	H5G / -S / -Z	X5G-Z / -S	ESG 4	ESG 5	HDG 2	ZSG 4	ZSG mini	DSG 4	Verso	HSG		
70	45		24				26,5			41,00										●				
70	70		24				26,5			41,00										●				

## Snelwisselbek met Prägeprofil

- ▲ prijs per stuk
- ▲ passend op LANG Prägeprofil

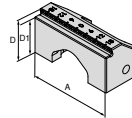

voor basisbreedte	A	A <sub>1</sub>	D	D <sub>1</sub>	D <sub>2</sub>	E	M	M <sub>1</sub>	M <sub>2</sub>	EUR	Y4	NCG	H5G / -S / -Z	X5G-Z / -S	ESG 4	ESG 5	HDG 2	ZSG 4	ZSG mini	DSG 4	Verso	HSG		
70	45		22	19						77,80										●				
70	70		22	19						77,80										●				

## Snelwisselbek met Prägeprofil, VS

- ▲ prijs per stuk
- ▲ passend op LANG Prägeprofil
- ▲ VS = vergroot spanbereik

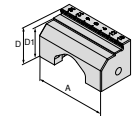

voor basisbreedte	A	A <sub>1</sub>	D	D <sub>1</sub>	D <sub>2</sub>	E	M	M <sub>1</sub>	M <sub>2</sub>	EUR	Y4	NCG	H5G / -S / -Z	X5G-Z / -S	ESG 4	ESG 5	HDG 2	ZSG 4	ZSG mini	DSG 4	Verso	HSG		
70	45		22	19						95,00										●				
70	70		22	19						95,00										●				

## Overzicht systeem-toebehoren

### Dop

▲ passend op vierkant 3/8"

ESG 4	ZSG 4
ZSG mini	DSG 4
MSG 2	



vierkant		DRVS mm	<b>80 875 ...</b>
3/8"		11	EUR Y4 18,20 11100



→ pagina 176+180

Hier vindt u de geschikte „magnetische werkstukaanslag“ en „momentsleutel“ (Artikel-nrs **80 892 23800** en **80 884 402**).

### Cilinderkopschroef met binnenzeskant

▲ prijs per stuk

ZSG mini
-------------



G			<b>80 912 ...</b>
M6x25			EUR Y4 1,20 50100

### Stift

▲ prijs per stuk

ZSG mini
-------------

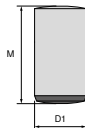

D <sub>1</sub> m6 mm		M mm	<b>80 912 ...</b>
12		18	EUR Y4 2,30 50200

DSG 4

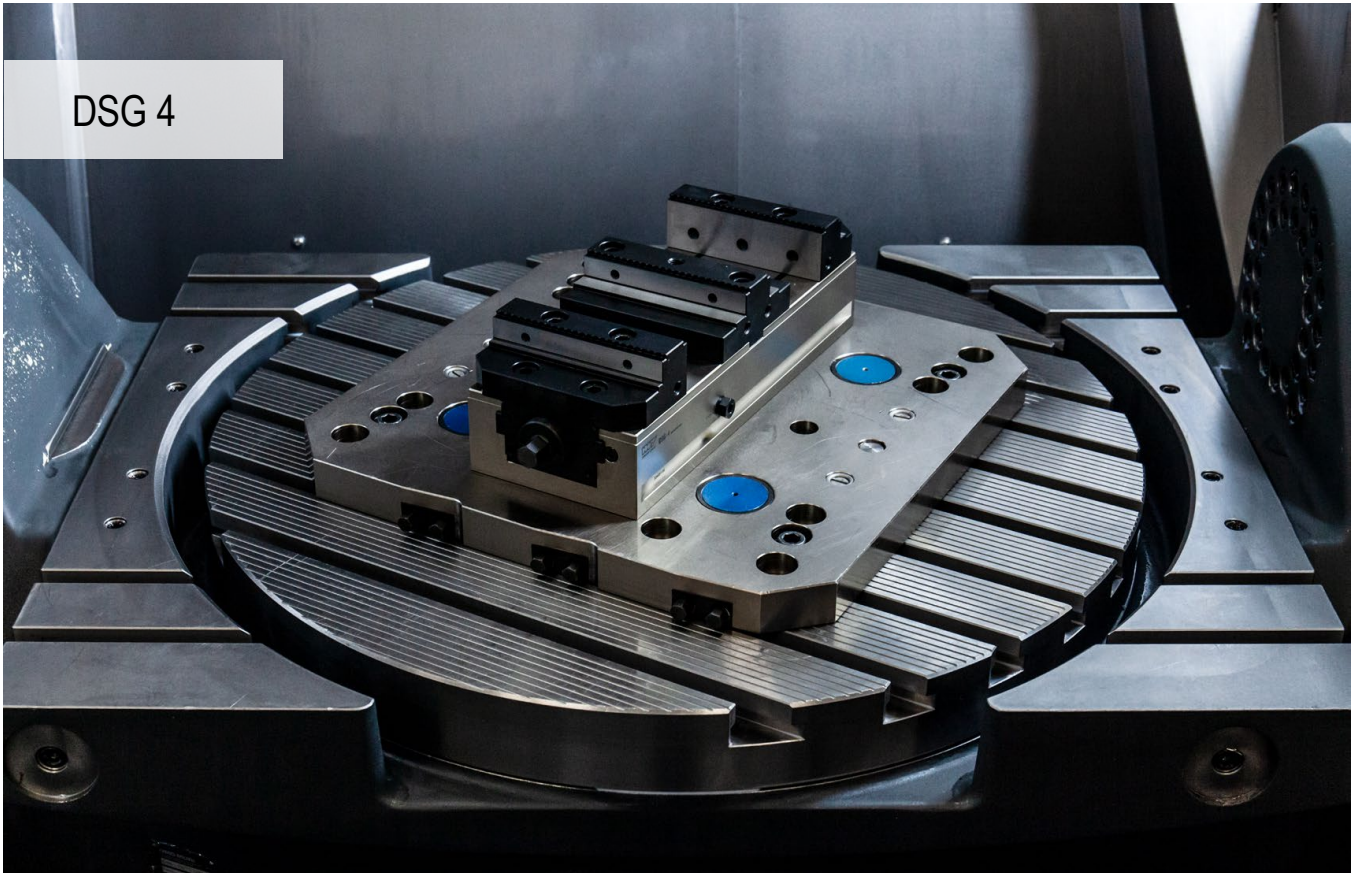

## Hoge nauwkeurigheid en zeer efficiënt

Het gebruiksvriendelijke spansysteem DSG 4 garandeert een langdurige hoge nauwkeurigheid en een breed inzetgebied.

### Uw voordelen:

- ▲ eenvoudige en robuuste derdehand functie
- ▲ eenvoudig en snel positioneren op het MNG-nulpunt spansysteem
- ▲ hoge spankrachten tussen 5 – 40 kN met gering aantrekmoment
- ▲ eenvoudiger en sneller wisselen van bekken met 2 bouten
- ▲ omvangrijk modulair bekkenprogramma

### Opspannen / uitlijnen:



Bevestiging met MNG nulpunt spansysteem  
(2-3 opnamepennen)



Bevestiging door de basis met vier M8 bouten

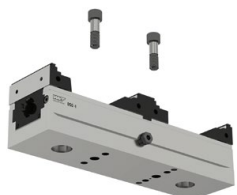

Bevestiging door de basis met twee  
pasbouten Artikel-nr. 80 895 019



Bevestiging met 4-6 klemvingers Artikel-nr. 80 890 315

## Spankracht:

## Aantrekmoment / spankracht DSG 4 – 80 mm

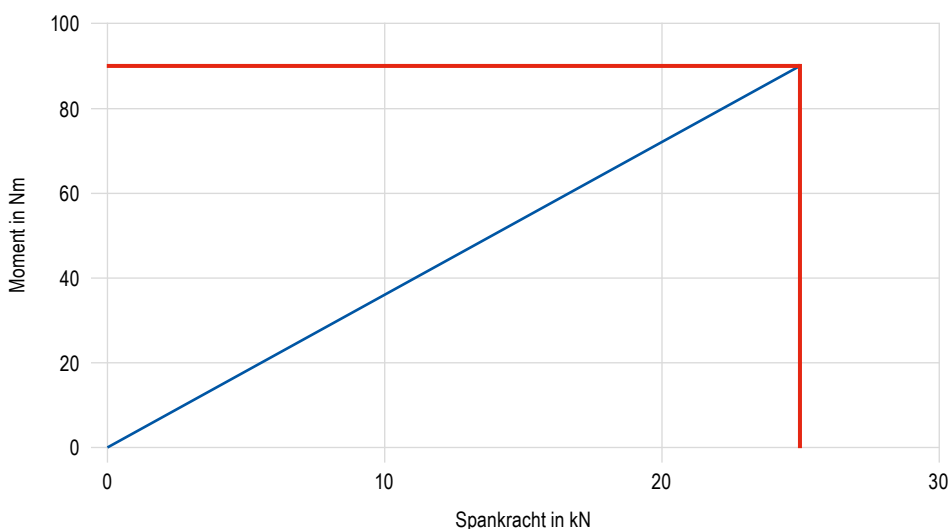

## Aantrekmoment / spankracht DSG 4 – 125 mm

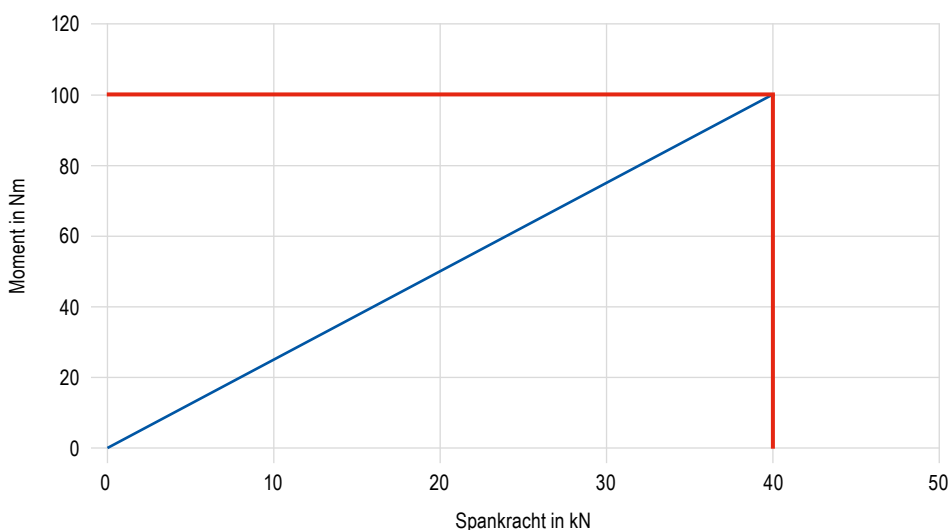

## Derdehand bediening

Het functioneren van de derdehand bediening bij een DSG 4 wordt met behulp van voorspanning op de achterste schuiver door middel van drukveren gewaarborgd.



De zijdelingse klem Schroef A is niet vastgedraaid, maar ca. 1/2 omwenteling los. Bij maximaal geopende klem moeten de losse bekken B en C in de desbetreffende gleuven van de schuiver D en E geplaatst en vastgezet worden, afhankelijk van de werkstuk grootte. Er kunnen ook 2 werkstukken met verschillende grootte opgespannen worden.

## Ombouw naar enkelspanner



Door middel van de inbusbout wordt de achterste schuiver geblokkeerd en kan de DSG 4 ook als enkelspanner gebruikt worden. **Belangrijke tip:** Niet geschikt bij gebruik van meerdere klemmen als enkelspanner naast elkaar. Hier bevelen wij de modificatie aan met extra dwarsgleuf in de basis en de daarbij behorende vaste bek.

## PolyClamp – DSG 4

- ▲ dubbelspanner zonder bekken
- ▲ 100 % ingekapseld
- ▲ snelle demontage en montage
- ▲ flexibel spansysteem

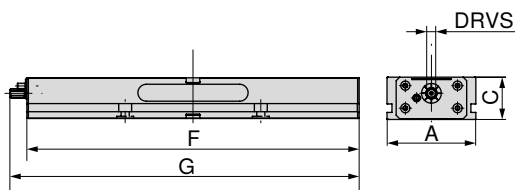
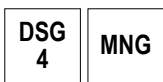

								80 906 ...	
								EUR	
A	C	F	G	TQX	DRVS	MXC	WT	Y4	
mm	mm	mm	mm	Nm	mm	kN	kg		
80	55	300	308	90	12	0 - 25	8	1.560,00	080
125	60	320	347	100	14	0 - 40	14	1.850,00	125
125	60	390	417	100	14	0 - 40	17	2.040,00	12700
125	60	460	487	100	14	0 - 40	20	2.300,00	12800
125	60	530	557	100	14	0 - 40	24	2.510,00	12900
125	60	600	627	100	14	0 - 40	27	2.720,00	13000
125	60	670	697	100	14	0 - 40	30	2.840,00	13100
125	60	740	767	100	14	0 - 40	34	2.950,00	126

### Klemmengids

Maattabellen voor de verschillende bekken	105-107	Systeem-toebehoren	108+110
Derdehand bediening	102	Ombouw naar enkelspanner	103
MNG-/PNG nulpuntspansysteem	134-163	Algemeen toebehoren	164-183

## Maten van de onderzijde van DSG 4

Basisbreedte 80 mm  
en lengte 300 mm

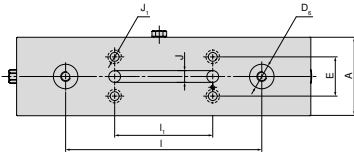

A	D <sub>6</sub> H6	E ±0.015	I ±0.01	I <sub>1</sub> ±0.01	J H7	J <sub>1</sub>
mm	mm	mm	mm	mm	mm	mm
80	25	40	200	100	12	9

Basisbreedte 125 mm  
en lengte 460 mm, 530 mm

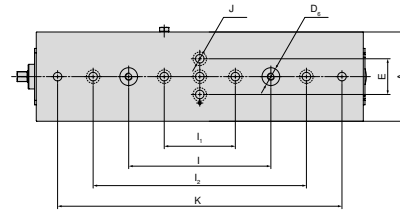

A	D <sub>6</sub> H6	E ±0.015	I ±0.01	I <sub>1</sub> ±0.01	I <sub>2</sub> ±0.002	J H7	K ±0.002
mm	mm	mm	mm	mm	mm	mm	mm
125	25	50	200	100	300	12	400
125	25	50	200	100	300	12	500

Basisbreedte 125 mm  
en lengte 320 mm

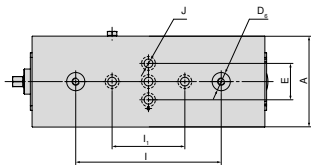

A	D <sub>6</sub> H6	E ±0.015	I ±0.01	I <sub>1</sub> ±0.01	J H7
mm	mm	mm	mm	mm	mm
125	25	50	200	100	12

Basisbreedte 125 mm  
en lengte 600 mm

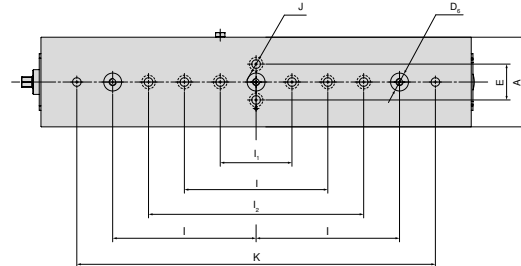

A	D <sub>6</sub> H6	E ±0.015	I ±0.01	I <sub>1</sub> ±0.01	I <sub>2</sub> ±0.002	J H7	K ±0.002
mm	mm	mm	mm	mm	mm	mm	mm
125	25	50	200	100	300	12	500

Basisbreedte 125 mm  
en lengte 390 mm

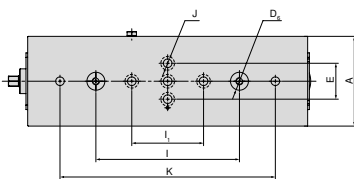

A	D <sub>6</sub> H6	E ±0.015	I ±0.01	I <sub>1</sub> ±0.01	J H7	K ±0.002
mm	mm	mm	mm	mm	mm	mm
125	25	50	200	100	12	300

Basisbreedte 125 mm  
en lengte 670 mm, 740 mm

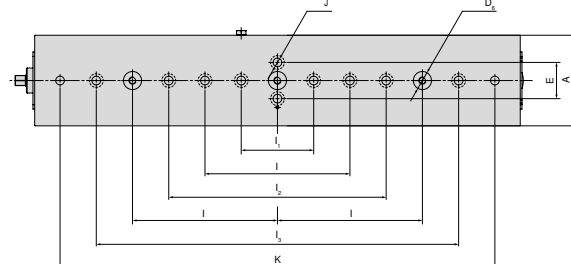

A	D <sub>6</sub> H6	E ±0.015	I ±0.01	I <sub>1</sub> ±0.01	I <sub>2</sub> ±0.002	I <sub>3</sub> ±0.025	J H7	K ±0.002
mm	mm	mm	mm	mm	mm	mm	mm	mm
125	25	50	200	100	300	500	12	600
125	25	50	200	100	300	500	12	700

## DSG 4 maattabellen voor de verschillende bekken

met gripbekken en grip middenbek

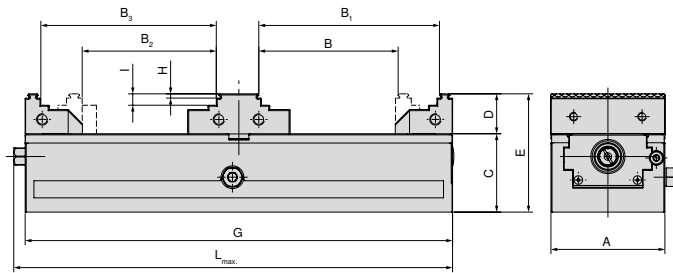

A mm	B mm	B <sub>1</sub> mm	B <sub>2</sub> mm	B <sub>3</sub> mm	C mm	D mm	E mm	G mm	H mm	I mm	L <sub>max</sub> mm	Artikel-nr. Systeembekken
80	25 - 97	54 - 126	31 - 93	51 - 122	55	28	83	300	3	8	308	2 x <b>80 878 810</b> + <b>80 906 300</b>
125	40 - 86	75 - 121	42 - 79	68 - 114	60	40	100	320	3	18	347	2 x <b>80 901 303</b> + <b>80 906 304</b>
125	40 - 121	75 - 156	42 - 114	68 - 149	60	40	100	390	3	18	417	2 x <b>80 901 303</b> + <b>80 906 304</b>
125	40 - 156	75 - 191	42 - 149	68 - 184	60	40	100	460	3	18	487	2 x <b>80 901 303</b> + <b>80 906 304</b>
125	40 - 191	75 - 226	42 - 184	68 - 219	60	40	100	530	3	18	557	2 x <b>80 901 303</b> + <b>80 906 304</b>
125	40 - 226	75 - 261	42 - 219	68 - 254	60	40	100	600	3	18	627	2 x <b>80 901 303</b> + <b>80 906 304</b>
125	40 - 261	75 - 296	42 - 254	68 - 289	60	40	100	670	3	18	697	2 x <b>80 901 303</b> + <b>80 906 304</b>
125	40 - 296	75 - 331	42 - 289	68 - 324	60	40	100	740	3	18	767	2 x <b>80 901 303</b> + <b>80 906 304</b>

met gripbekken en gladde middenbek

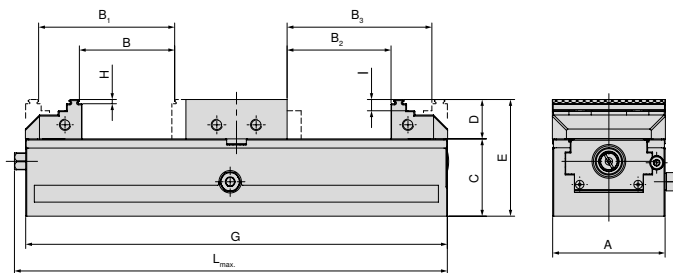

A mm	B mm	B <sub>1</sub> mm	B <sub>2</sub> mm	B <sub>3</sub> mm	C mm	D mm	E mm	G mm	H mm	I mm	L <sub>max</sub> mm	Artikel-nr. Systeembekken
80	5 - 67	34 - 96	0 - 73	40 - 102	55	28	83	300	3	8	308	2 x <b>80 878 810</b> + <b>80 906 301</b>
125	7 - 44	42 - 77	0 - 47	46 - 82	60	40	100	320	3	18	347	2 x <b>80 901 303</b> + <b>80 906 305</b>
125	7 - 79	42 - 112	0 - 82	46 - 117	60	40	100	390	3	18	417	2 x <b>80 901 303</b> + <b>80 906 305</b>
125	7 - 114	42 - 149	0 - 117	46 - 152	60	40	100	460	3	18	487	2 x <b>80 901 303</b> + <b>80 906 305</b>
125	7 - 147	42 - 182	0 - 152	46 - 187	60	40	100	530	3	18	557	2 x <b>80 901 303</b> + <b>80 906 305</b>
125	7 - 184	42 - 217	0 - 187	46 - 222	60	40	100	600	3	18	627	2 x <b>80 901 303</b> + <b>80 906 305</b>
125	7 - 219	42 - 252	0 - 222	46 - 257	60	40	100	670	3	18	697	2 x <b>80 901 303</b> + <b>80 906 305</b>
125	7 - 254	42 - 287	0 - 257	46 - 292	60	40	100	740	3	18	767	2 x <b>80 901 303</b> + <b>80 906 305</b>



## DSG 4 maattabellen voor de verschillende bekken

Met blokbekken en gladde middenbek

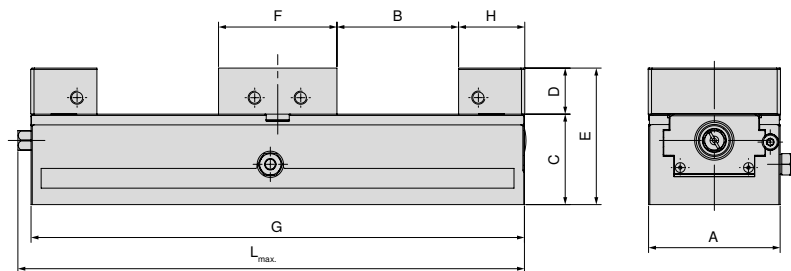

A mm	B mm	C mm	D mm	E mm	F mm	G mm	H mm	L <sub>max.</sub> mm	Artikel-nr. Systeembekken
80	0 - 73	55	28	83	72	300	40	308	2 x 80 901 31300 + 80 906 301
125	0 - 46	60	40	100	98	320	66	347	2 x 80 901 31500 + 80 906 305
125	0 - 81	60	40	100	98	390	66	417	2 x 80 901 31500 + 80 906 305
125	0 - 116	60	40	100	98	460	66	487	2 x 80 901 31500 + 80 906 305
125	0 - 151	60	40	100	98	530	66	557	2 x 80 901 31500 + 80 906 305
125	0 - 186	60	40	100	98	600	66	627	2 x 80 901 31500 + 80 906 305
125	0 - 221	60	40	100	98	670	66	697	2 x 80 901 31500 + 80 906 305
125	0 - 256	60	40	100	98	740	66	767	2 x 80 901 31500 + 80 906 305

met pendelbekken en adapterplaten

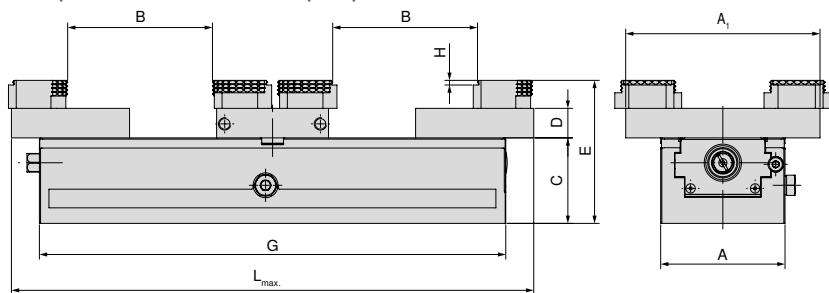

A mm	A <sub>1</sub> mm	B mm	C mm	D mm	E mm	G mm	H mm	L <sub>max.</sub> mm	Artikel-nr. Systeembekken
80	125	0 - 92	55	19	92	300	3	308	2 x 80 878 870 + 80 906 303
125	180	7 - 92	60	22	100	320	3	365	2 x 80 878 570 + 80 906 307
125	180	7 - 133	60	22	100	390	3	435	2 x 80 878 570 + 80 906 307
125	180	7 - 168	60	22	100	460	3	505	2 x 80 878 570 + 80 906 307
125	180	7 - 203	60	22	100	530	3	575	2 x 80 878 570 + 80 906 307
125	180	7 - 238	60	22	100	600	3	645	2 x 80 878 570 + 80 906 307
125	180	7 - 273	60	22	100	670	3	715	2 x 80 878 570 + 80 906 307
125	180	7 - 308	60	22	100	740	3	785	2 x 80 878 570 + 80 906 307

## DSG 4 maattabellen voor de verschillende bekken

Met aluminium bekken en aluminium middenbek

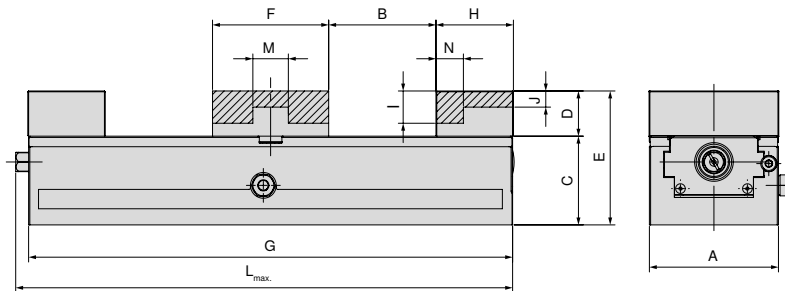

A mm	B mm	C mm	D mm	E mm	F mm	G mm	H mm	I mm	J mm	L <sub>max.</sub> mm	M mm	N mm	Artikel-nr. Systeembekken
80	0 - 66	55	28	83	72	300	40	20	10	308	22	17	2 x <b>80 878 850</b> + <b>80 906 302</b>
125	0 - 42	60	40	100	98	320	68		17	347	38	28	2 x <b>80 878 550</b> + <b>80 906 306</b>
125	0 - 77	60	40	100	98	390	68		17	417	38	28	2 x <b>80 878 550</b> + <b>80 906 306</b>
125	0 - 112	60	40	100	98	460	68		17	487	38	28	2 x <b>80 878 550</b> + <b>80 906 306</b>
125	0 - 147	60	40	100	98	530	68		17	557	38	28	2 x <b>80 878 550</b> + <b>80 906 306</b>
125	0 - 182	60	40	100	98	600	68		17	627	38	28	2 x <b>80 878 550</b> + <b>80 906 306</b>
125	0 - 217	60	40	100	98	670	68		17	697	38	28	2 x <b>80 878 550</b> + <b>80 906 306</b>
125	0 - 252	60	40	100	98	740	68		17	767	38	28	2 x <b>80 878 550</b> + <b>80 906 306</b>

## Overzicht systeembekken

### Gripbek 3 mm, los

▲ prijs per stuk

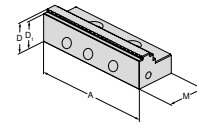

voor basisbreedte	A	A <sub>1</sub>	D	D <sub>1</sub>	D <sub>2</sub>	E	M	M <sub>1</sub>	M <sub>2</sub>	EUR	Y4	NCG	H5G / -S / -Z	X5G-Z / -S	ESG 4	ESG 5	HDG 2	ZSG 4	ZSG mini	DSG 4	Verso	HSG	
125	125		40	37			66			224,00					●	●				●			

### Gripbek 3 mm, los

▲ prijs per stuk

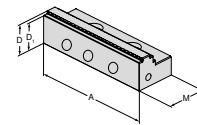

voor basisbreedte	A	A <sub>1</sub>	D	D <sub>1</sub>	D <sub>2</sub>	E	M	M <sub>1</sub>	M <sub>2</sub>	EUR	Y4	NCG	H5G / -S / -Z	X5G-Z / -S	ESG 4	ESG 5	HDG 2	ZSG 4	ZSG mini	DSG 4	Verso	HSG	
80	80		28	25			40			135,00					●	●		●		●			

### Tussenbek, grip

▲ prijs per stuk

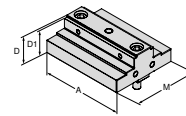

voor basisbreedte	A	A <sub>1</sub>	D	D <sub>1</sub>	D <sub>2</sub>	E	M	M <sub>1</sub>	M <sub>2</sub>	EUR	Y4	NCG	H5G / -S / -Z	X5G-Z / -S	ESG 4	ESG 5	HDG 2	ZSG 4	ZSG mini	DSG 4	Verso	HSG	
80	80		28	25			72			278,00											●		
125	125		40	37			98			370,00											●		

### Tussenbek, glad

▲ prijs per stuk

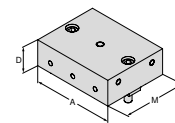

voor basisbreedte	A	A <sub>1</sub>	D	D <sub>1</sub>	D <sub>2</sub>	E	M	M <sub>1</sub>	M <sub>2</sub>	EUR	Y4	NCG	H5G / -S / -Z	X5G-Z / -S	ESG 4	ESG 5	HDG 2	ZSG 4	ZSG mini	DSG 4	Verso	HSG	
80	80		28				72			214,00											●		
125	125		40				98			317,00											●		

## Overzicht systeembekken

### Zachte opzetbek (aluminium)

- ▲ voor het maken van vormbekken
- ▲ prijs per stuk

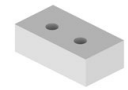
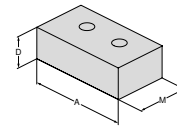

voor basisbreedte	A	A <sub>1</sub>	D	D <sub>1</sub>	D <sub>2</sub>	E	M	M <sub>1</sub>	M <sub>2</sub>	EUR	Y4	NCG	H5G / -S / -Z	X5G-Z / -S	ESG 4	ESG 5	HDG 2	ZSG 4	ZSG mini	DSG 4	Verso	HSG	
80	80		28				48			86,40	80 878 850				●	●		●		●			
125	125		40				68			98,30	80 878 550				●						●		

### Tussenbek, aluminium

- ▲ voor het maken van vormbekken
- ▲ prijs per stuk

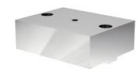
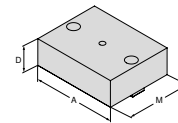

voor basisbreedte	A	A <sub>1</sub>	D	D <sub>1</sub>	D <sub>2</sub>	E	M	M <sub>1</sub>	M <sub>2</sub>	EUR	Y4	NCG	H5G / -S / -Z	X5G-Z / -S	ESG 4	ESG 5	HDG 2	ZSG 4	ZSG mini	DSG 4	Verso	HSG	
80	80		28				72			77,80	80 906 302										●		
125	125		40				98			105,00	80 906 306										●		

### Blokbeek, los

- ▲ prijs per stuk

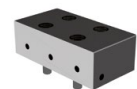
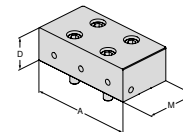

voor basisbreedte	A	A <sub>1</sub>	D	D <sub>1</sub>	D <sub>2</sub>	E	M	M <sub>1</sub>	M <sub>2</sub>	EUR	Y4	NCG	H5G / -S / -Z	X5G-Z / -S	ESG 4	ESG 5	HDG 2	ZSG 4	ZSG mini	DSG 4	Verso	HSG	
80	80		28				40			244,00	80 901 31300				●	●		●		●			
125	125		40				66			342,00	80 901 31500				●						●		

### Pendelbek, los

- ▲ voor opname van 6-voudige bekken
- ▲ prijs per stuk

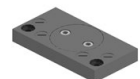
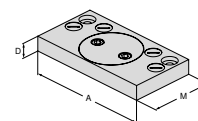

voor basisbreedte	A	A <sub>1</sub>	D	D <sub>1</sub>	D <sub>2</sub>	E	M	M <sub>1</sub>	M <sub>2</sub>	EUR	Y4	NCG	H5G / -S / -Z	X5G-Z / -S	ESG 4	ESG 5	HDG 2	ZSG 4	ZSG mini	DSG 4	Verso	HSG	
80	125		19				76			409,00	80 878 870				●								
125	180		22				95			426,00	80 878 570				●			●		●			

## Overzicht systeembekken

### Tussenbek adapterplaat, vast

- ▲ voor opname van 6-voudige bekken
- ▲ prijs per stuk

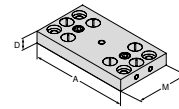

voor basisbreedte	A	A <sub>1</sub>	D	D <sub>1</sub>	D <sub>2</sub>	E	M	M <sub>1</sub>	M <sub>2</sub>	EUR	Y4	NCG	H5G / -S / -Z	X5G-Z / -S	ESG 4	ESG 5	HDG 2	ZSG 4	ZSG mini	DSG 4	Verzo	HSG			
80	125		19				72			291,00															
125	180		22				98			346,00															

### 6-voudige bek

- ▲ 1 = glad, wolframcarbide gecoat
- ▲ 2 = grip met trap 3 mm
- ▲ 3 = grip met trap 8 mm
- ▲ 4 = grip met trap 18 mm
- ▲ 5 = grip met trap 8 mm
- ▲ 6 = grip rond
- ▲ M<sub>max</sub> = 60 Nm
- ▲ incl. bevestigingsbout

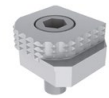
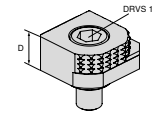

voor basisbreedte	A	A <sub>1</sub>	D	D <sub>1</sub>	D <sub>2</sub>	E	M	M <sub>1</sub>	M <sub>2</sub>	EUR	Y4	NCG	H5G / -S / -Z	X5G-Z / -S	ESG 4	ESG 5	HDG 2	ZSG 4	ZSG mini	DSG 4	Verzo	HSG			
			18							80,60															

### 6-voudige bek

- ▲ 1 = glad
- ▲ 2 = carbide grip
- ▲ 3 = carbide grip met trap 3 mm
- ▲ 4 = carbide grip met trap 8 mm
- ▲ 5 = carbide grip rond met trap 8 mm
- ▲ 6 = carbide grip rond
- ▲ incl. bevestigingsbout

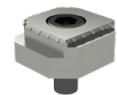
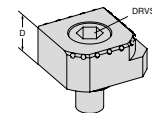

voor basisbreedte	A	A <sub>1</sub>	D	D <sub>1</sub>	D <sub>2</sub>	E	M	M <sub>1</sub>	M <sub>2</sub>	EUR	Y4	NCG	H5G / -S / -Z	X5G-Z / -S	ESG 4	ESG 5	HDG 2	ZSG 4	ZSG mini	DSG 4	Verzo	HSG			
			18							117,00															

## Overzicht systeem-toebehoren

### Afdichtstop kunststof

DSG  
4

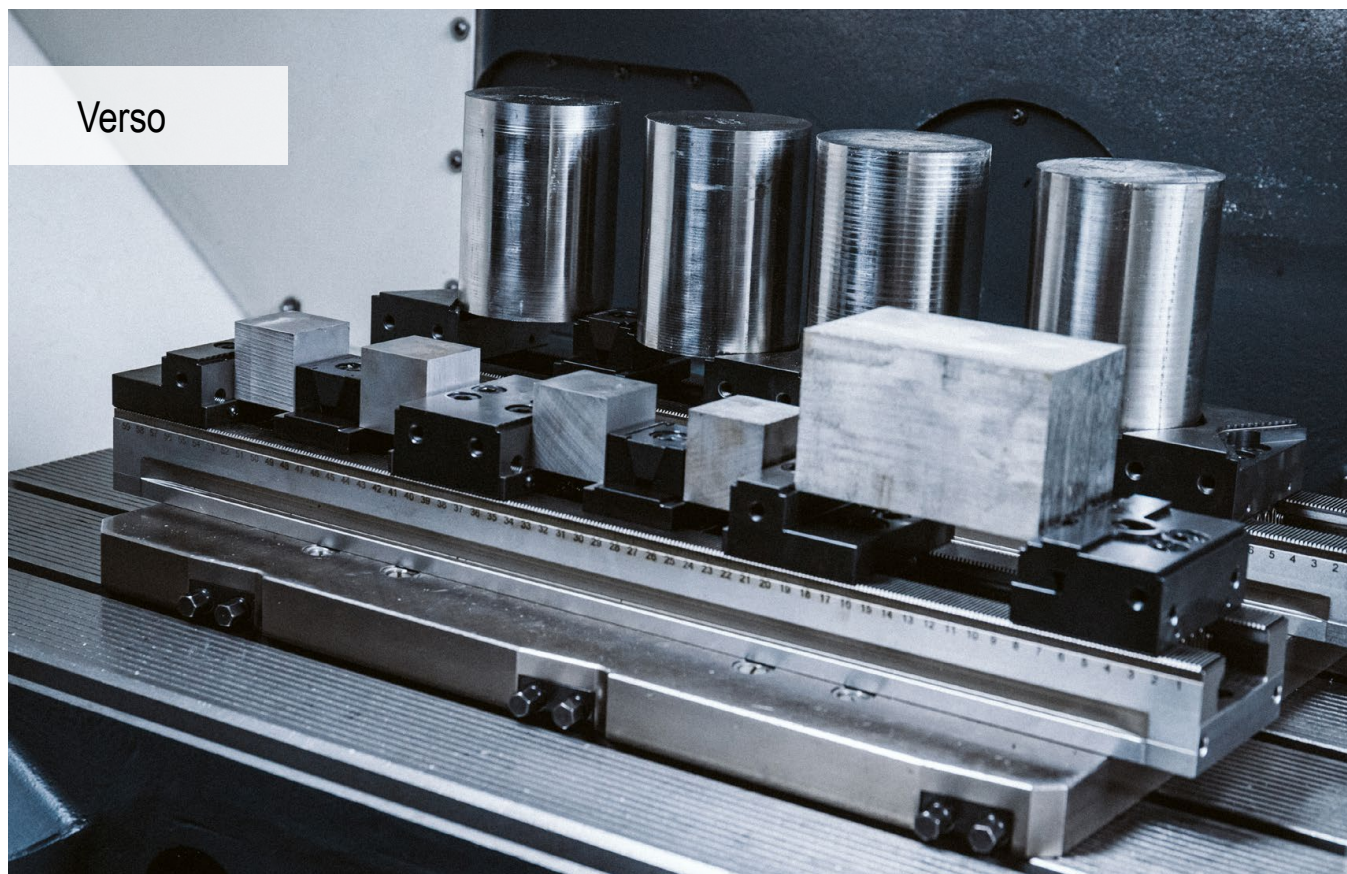

## De allrounder in de werkstukopspanning

Met de nieuwe meervoudige spanner kunnen zowel kleine als grote werkstukken eenvoudig op een 3-, 4- of 5-assige machines gespannen worden. Door gebruik van nog compactere bekken kan er een hoge werkstuk-dichtheid behaald worden.

### Uw voordelen:

- ▲ de geharde en geslepen vertanding zorgt voor de hoogste zekerheid en positienauwkeurigheid
- ▲ snelwisselbekken-systeem bij de vaste en losse bekken
- ▲ compleet programma voor alle soorten freesmachines
- ▲ meervoudige spanner met wig-klemming
- ▲ omvangrijk systeembekken-programma
- ▲ eenvoudige basisverlenging door verbindingstukken



### Opspannen / uitlijnen:

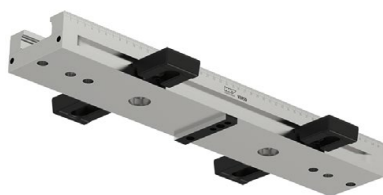

Met T-sleuven of schroeven uit te richten in T-gleuven (14, 16, 18 mm) met de bijpassende uitrichtset voor T-gleuf tafels. Voor T-moeren 12 mm: 2 paspennen Ø 12 gebruiken.



met klemvingers uitrichtset opspannen met aan de zijkant gemonteerde klemvingers.



Via rastergaten positionering en bevestiging via twee passschroeven Ø12f7 / M12, in het eerste en laatste gat van de body. Extra schroef montage met M12-cilinderkopschroeven door de resterende gaten.

## Opspannen / uitlijnen:



## Met nulpuntpansysteem

De basisrail is voorzien van MNG-boringen, waarin de MNG-opnamepennen kunnen worden bevestigd (tot een basislengte van 500 mm = 2 of vanaf 600 mm = 3 opnamepennen).

## Spankracht:

## Aandraaimoment / spankracht Verso

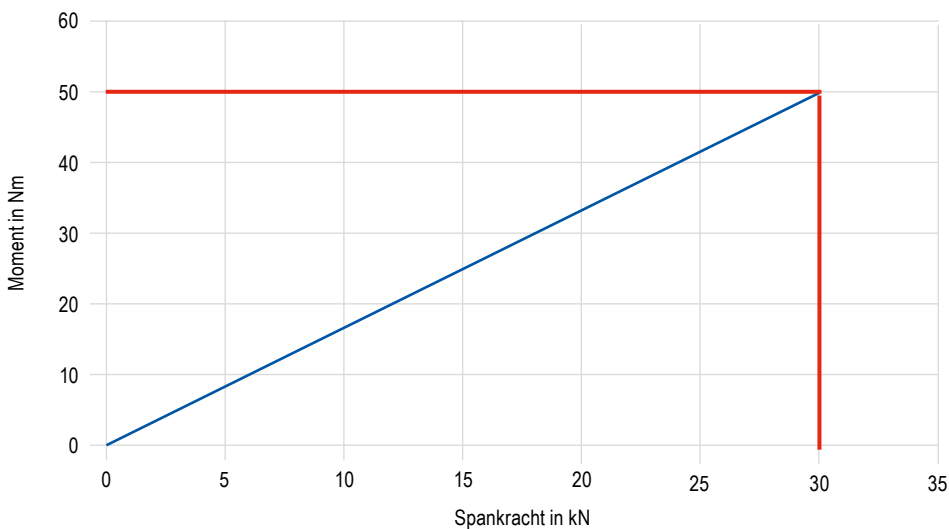

## Snel te wisselen vaste en losse bekken

De meervoudige Verso spanner is standaard met een snelwisselbekken-systeem uitgerust. De vaste en losse bekken kunnen met twee schroeven worden losgemaakt, verwijderd of verplaatst. De bekken worden van bovenaf verwijderd. Op deze manier kan elke bek worden verwijderd zonder een andere te moeten verwijderen. Dit verkort de steltijd en stilstand aanzienlijk.

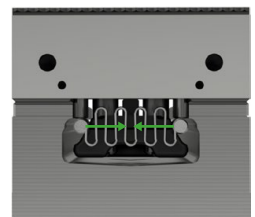

losse situatie

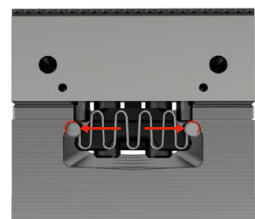

gemonteerde situatie



schroeven losdraaien



verwijderen en verplaatsen



schroeven aandraaien

## Snelwissel van de bekken

De vaste en losse bekken van de meervoudige Verso spanner zijn standaard met een snelwissel-systeem uitgerust. De bekken kunnen eenvoudig met 2 schroeven gemonteerd of gedemonteerd worden. Daardoor zijn snelle wissels mogelijk.

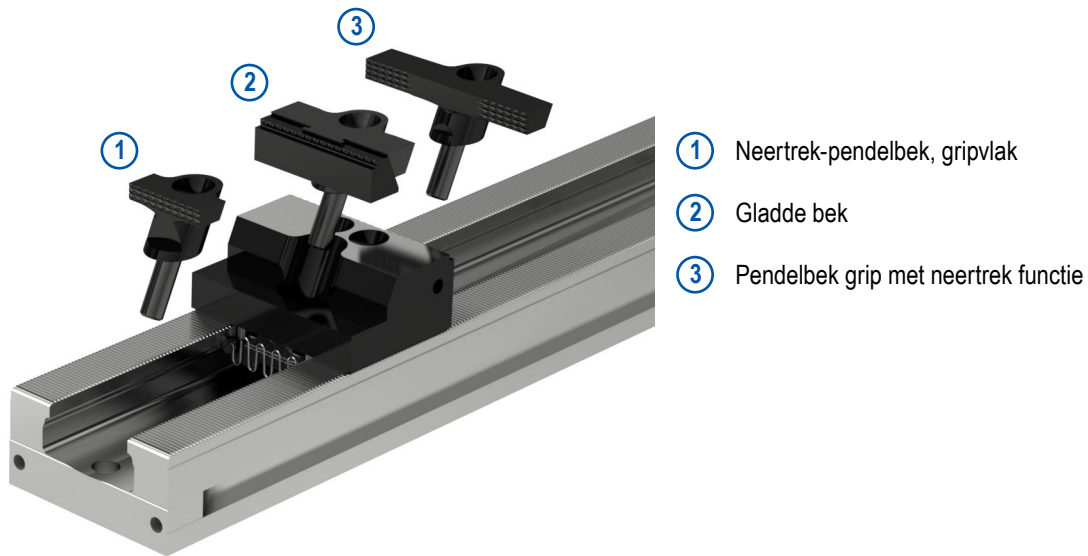

## Verlenging van de basisrails

Door het verbindingsstuk kunnen twee of meerdere Verso-basisrails aan elkaar verbonden worden.

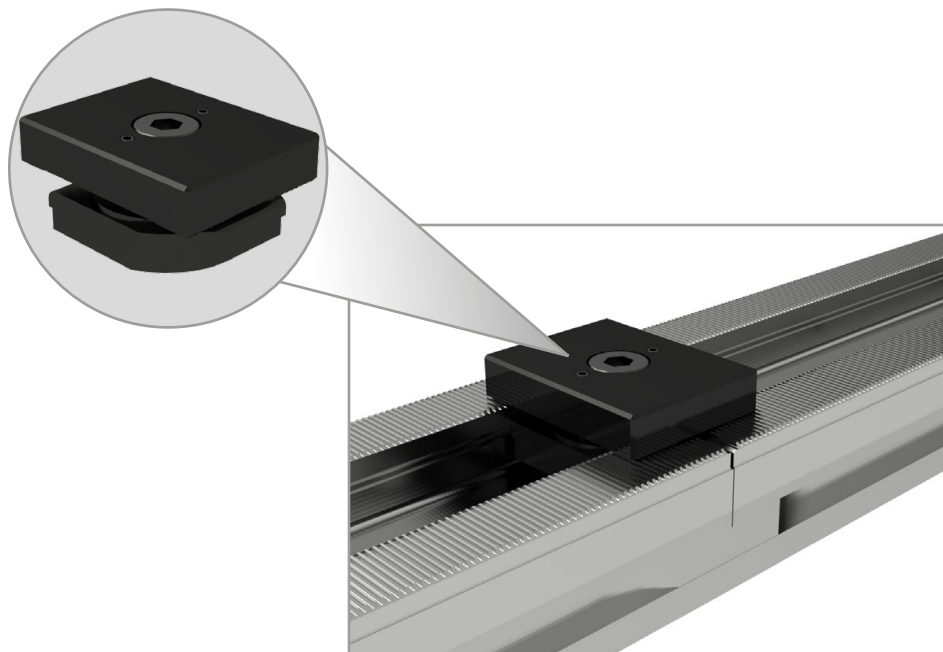



## PolyClamp – Verso

- ▲ inzetbaar voor enkel- en meervoudige opspanning
- ▲ meervoudige spanner met wig-klemelementen
- ▲ werkstukken op 3-, 4- en 5-assige machines op te spannen
- ▲ opname op MNG en adapterplaten is mogelijk

### leveromvang:

basisrail zonder bekken

Verso

MMG

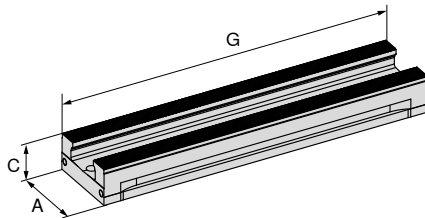

NEW

80 914 ...

EUR

Y4

A mm	C mm	G mm	MXC kN	WT kg	
90	45	260	0 - 50	5,0	804,00 09000
90	45	400	0 - 50	7,7	1.060,00 09100
90	45	500	0 - 50	9,6	1.280,00 09200
90	45	600	0 - 50	11,5	1.540,00 09300
90	45	650	0 - 50	12,5	1.640,00 09400

## Verso – Maattabel voor de verschillende bekken

basisrail

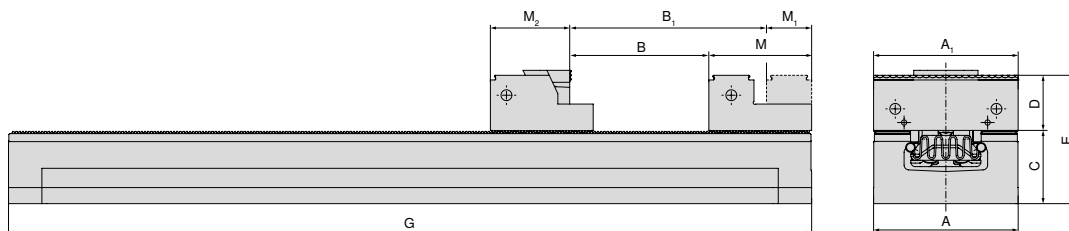

A mm	A <sub>1</sub> mm	B mm	B <sub>1</sub> mm	C mm	D mm	E mm	G mm	M mm	M <sub>1</sub> mm	M <sub>2</sub> mm
90	40 / 65 / 90	145	181	45	35	80	260	64	28	53,5
90	40 / 65 / 90	285	321	45	35	80	400	64	28	53,5
90	40 / 65 / 90	385	421	45	35	80	500	64	28	53,5
90	40 / 65 / 90	485	521	45	35	80	600	64	28	53,5
90	40 / 65 / 90	535	571	45	35	80	650	64	28	53,5



Bij gebruik van de grip-pendelbek 90 mm en gladde bekken kijken de maten B, B<sub>1</sub> en M<sub>2</sub> af.

### Klemmengids

Maten van de onderzijde	115	Overzicht spanbereik	116
Systeem-toebehoren	117-124	Algemeen toebehoren	164-183

## Maten van de onderzijde – Verso

Basisbreedte 90 mm  
en lengte 260 mm

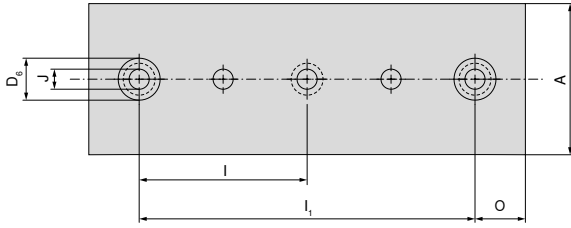

A	D <sub>6</sub> H7	I <sub>±0,015</sub>	I <sub>1±0,015</sub>	J <sub>F7</sub>	O <sub>±0,015</sub>
mm	mm	mm	mm	mm	mm
90	25	100	200	12	30

Basisbreedte 90 mm  
en lengte 600 mm

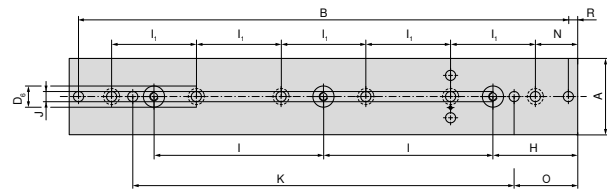

A	B	D <sub>6</sub> H7	H <sub>±0,015</sub>	I <sub>±0,015</sub>	I <sub>1±0,015</sub>	J <sub>F7</sub>	K <sub>±0,015</sub>	N	O <sub>±0,015</sub>	R
mm	mm	mm	mm	mm	mm	mm	mm	mm	mm	mm
90	578	25	100	200	100	12	450	50	75	11

Basisbreedte 90 mm  
en lengte 400 mm

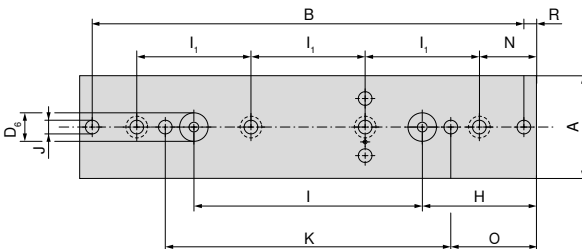

A	B	D <sub>6</sub> H7	H <sub>±0,015</sub>	I <sub>±0,015</sub>	I <sub>1±0,015</sub>	J <sub>F7</sub>	K <sub>±0,015</sub>	N	O <sub>±0,015</sub>	R
mm	mm	mm	mm	mm	mm	mm	mm	mm	mm	mm
90	378	25	100	200	100	12	250	50	75	11

Basisbreedte 90 mm  
en lengte 650 mm

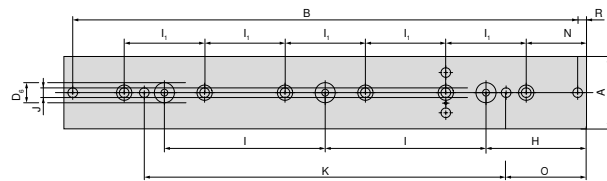

A	B	D <sub>6</sub> H7	H <sub>±0,015</sub>	I <sub>±0,015</sub>	I <sub>1±0,015</sub>	J <sub>F7</sub>	K <sub>±0,015</sub>	N	O <sub>±0,015</sub>	R
mm	mm	mm	mm	mm	mm	mm	mm	mm	mm	mm
90	628	25	125	200	100	12	450	75	100	11

Basisbreedte 90 mm  
en lengte 500 mm

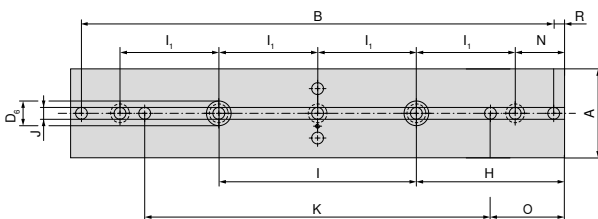

A	B	D <sub>6</sub> H7	H <sub>±0,015</sub>	I <sub>±0,015</sub>	I <sub>1±0,015</sub>	J <sub>F7</sub>	K <sub>±0,015</sub>	N	O <sub>±0,015</sub>	R
mm	mm	mm	mm	mm	mm	mm	mm	mm	mm	mm
90	478	25	150	200	100	12	350	50	75	11

## Overzicht systeembekken – Verso

De spanbreedte geeft de max. werkstukgrootte aan, afhankelijk van het aantal spanpunten voor de afzonderlijke basislengtes.

### Losse bek met neertrekbek grip 40 mm

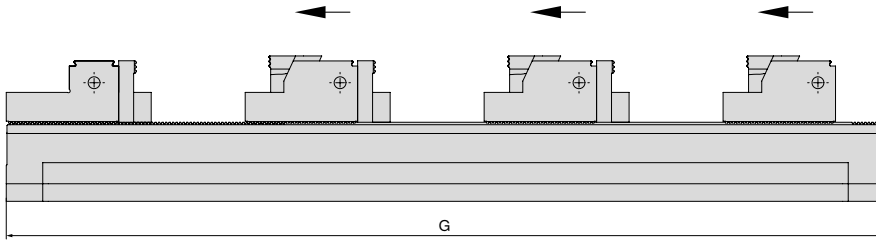

G mm	Aantal werkstukken							Artikel-nr. Machineklemmen
	1	2	3	4	5	6	7	
260	134	36	–	–	–	–	–	<b>80 914 09000</b>
400	274	106	50	22	–	–	–	<b>80 914 09100</b>
500	374	156	82	45	24	–	–	<b>80 914 09200</b>
600	474	206	116	72	44	26	–	<b>80 914 09300</b>
650	524	230	135	84	54	34	20	<b>80 914 09400</b>

### Losse gladde bekken met gladde vaste bek

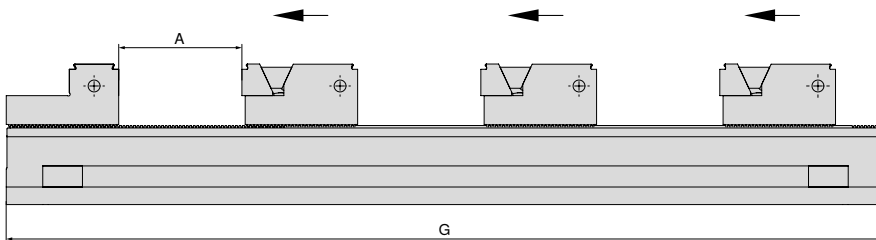

G mm	Aantal werkstukken									Artikel-nr. Machineklemmen
	1 A	2 A	3 A	4 A	5 A	6 A	7 A	8 A	9 A	
260	175	59	–	–	–	–	–	–	–	<b>80 914 09000</b>
400	315	129	67	27	10	–	–	–	–	<b>80 914 09100</b>
500	415	179	100	61	30	15	–	–	–	<b>80 914 09200</b>
600	515	229	133	86	57	32	19	10	–	<b>80 914 09300</b>
650	565	254	150	98	67	46	26	16	8	<b>80 914 09400</b>

### Met klemwig-bekken

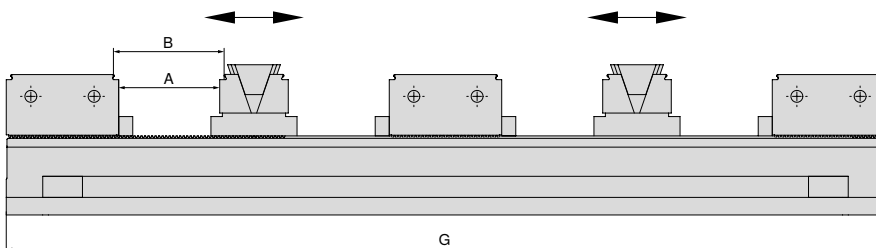

G mm	Aantal werkstukken								Artikel-nr. Machineklemmen
	2		4		6		8		
	A	B	A	B	A	B	A	B	
260	45	50	–	–	–	–	–	–	<b>80 914 09000</b>
400	115	120	31	36	–	–	–	–	<b>80 914 09100</b>
500	165	170	56	61	19	24	–	–	<b>80 914 09200</b>
600	215	220	81	86	36	41	14	19	<b>80 914 09300</b>
650	240	245	93	98	44	49	20	25	<b>80 914 09400</b>

## Overzicht systeembekken

### Vaste bek, grip 2,9 mm

▲ prijs per stuk

voor basisbreedte	A	A <sub>1</sub>	D	D <sub>1</sub>	D <sub>2</sub>	E	M	M <sub>1</sub>	M <sub>2</sub>	EUR	Y4	NCG	H5G / -S / -Z	X5G-Z / -S	ESG 4	ESG 5	HDG 2	ZSG 4	ZSG mini	DSG 4	Versto	HSG	
90	90		32	34,9			64			342,00	80 914 31800											●	

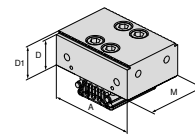

### Getrapte vaste bek, glad

▲ prijs per stuk

voor basisbreedte	A	A <sub>1</sub>	D	D <sub>1</sub>	D <sub>2</sub>	E	M	M <sub>1</sub>	M <sub>2</sub>	EUR	Y4	NCG	H5G / -S / -Z	X5G-Z / -S	ESG 4	ESG 5	HDG 2	ZSG 4	ZSG mini	DSG 4	Versto	HSG	
90	90		34,9	17			64	35,9	28,1	364,00	80 914 32000											●	

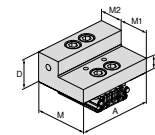

### Vaste bek, grip 2,9 mm

▲ prijs per stuk

voor basisbreedte	A	A <sub>1</sub>	D	D <sub>1</sub>	D <sub>2</sub>	E	M	M <sub>1</sub>	M <sub>2</sub>	EUR	Y4	NCG	H5G / -S / -Z	X5G-Z / -S	ESG 4	ESG 5	HDG 2	ZSG 4	ZSG mini	DSG 4	Versto	HSG	
90	65		34,9	32	17		64	28,1	35,9	352,00	80 914 31100											●	
90	65	40	34,9	32	17		64	28,1	35,9	340,00	80 914 31000											●	
90	90		34,9	32	17		64	28,1	35,9	364,00	80 914 31200											●	

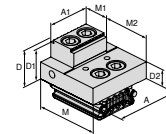

### Losse basisbek, grip 2,9 mm

▲ prijs per stuk

voor basisbreedte	A	A <sub>1</sub>	D	D <sub>1</sub>	D <sub>2</sub>	E	M	M <sub>1</sub>	M <sub>2</sub>	EUR	Y4	NCG	H5G / -S / -Z	X5G-Z / -S	ESG 4	ESG 5	HDG 2	ZSG 4	ZSG mini	DSG 4	Versto	HSG	
90	65		34,9	32	17		64	42	22	352,00	80 914 31400											●	
90	65	40	34,9	32	17		64	42	22	340,00	80 914 31300											●	
90	90		34,9	32	17		64	42	22	364,00	80 914 31500											●	

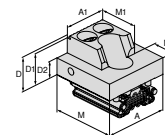

### Losse basisbek, glad

▲ prijs per stuk

voor basisbreedte	A	A <sub>1</sub>	D	D <sub>1</sub>	D <sub>2</sub>	E	M	M <sub>1</sub>	M <sub>2</sub>	EUR	Y4	NCG	H5G / -S / -Z	X5G-Z / -S	ESG 4	ESG 5	HDG 2	ZSG 4	ZSG mini	DSG 4	Versto	HSG	
90	90		34,9	17			64	42	22	364,00	80 914 31600											●	

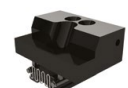
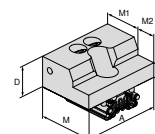

## Overzicht systeembekken

### Losse bek, hoog

▲ prijs per stuk

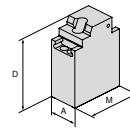

voor basisbreedte	A	A <sub>1</sub>	D	D <sub>1</sub>	D <sub>2</sub>	E	M	M <sub>1</sub>	M <sub>2</sub>
90	65		165				124		

EUR 1.220,00

NEW

Y4

NCG	H5G / -S / -Z	X5G-Z / -S	ESG 4	ESG 5	HDG 2	ZSG 4	ZSG mini	DSG 4	Verzo	HSG
									●	

80 914 31700

### Prisma bek, glad, grip 2,9 mm

▲ prijs per stuk

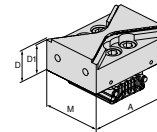

voor basisbreedte	A	A <sub>1</sub>	D	D <sub>1</sub>	D <sub>2</sub>	E	M	M <sub>1</sub>	M <sub>2</sub>
90	90		34,9	32			64		

EUR 364,00

NEW

Y4

NCG	H5G / -S / -Z	X5G-Z / -S	ESG 4	ESG 5	HDG 2	ZSG 4	ZSG mini	DSG 4	Verzo	HSG
									●	

80 914 31900

### Klemwig-bek, glad

▲ prijs per stuk

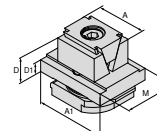

voor basisbreedte	A	A <sub>1</sub>	D	D <sub>1</sub>	D <sub>2</sub>	E	M	M <sub>1</sub>	M <sub>2</sub>
90	40	65	35	11			49		
90	40	65	39	11			49		

EUR 347,00  
236,00

NEW

Y4

NCG	H5G / -S / -Z	X5G-Z / -S	ESG 4	ESG 5	HDG 2	ZSG 4	ZSG mini	DSG 4	Verzo	HSG
									●	
									●	

80 914 32100  
80 914 32400

### Klemwig-bek, gripvlak

▲ prijs per stuk

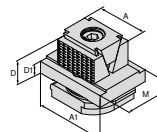

voor basisbreedte	A	A <sub>1</sub>	D	D <sub>1</sub>	D <sub>2</sub>	E	M	M <sub>1</sub>	M <sub>2</sub>
90	40	65	35	11			49		
90	40	65	39	11			49		

EUR 371,00  
236,00

NEW

Y4

NCG	H5G / -S / -Z	X5G-Z / -S	ESG 4	ESG 5	HDG 2	ZSG 4	ZSG mini	DSG 4	Verzo	HSG
									●	
									●	

80 914 32200  
80 914 32500

### Klemwig-bek, grip 3 mm

▲ prijs per stuk

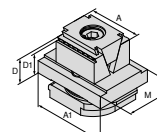

voor basisbreedte	A	A <sub>1</sub>	D	D <sub>1</sub>	D <sub>2</sub>	E	M	M <sub>1</sub>	M <sub>2</sub>
90	40	65	35	32			49		

EUR 371,00

NEW

Y4

NCG	H5G / -S / -Z	X5G-Z / -S	ESG 4	ESG 5	HDG 2	ZSG 4	ZSG mini	DSG 4	Verzo	HSG
									●	

80 914 32300

# Overzicht systeembekken

## Bek, grip

▲ prijs per stuk

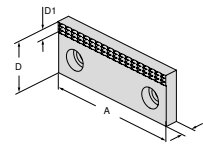

voor basisbreedte	A	A <sub>1</sub>	D	D <sub>1</sub>	D <sub>2</sub>	E	M	M <sub>1</sub>	M <sub>2</sub>	EUR	Y4	NEW	NCG	H5G / -S / -Z	X5G-Z / -S	ESG 4	ESG 5	HDG 2	ZSG 4	ZSG mini	DSG 4	Versto	HSG	
65	65		35	7			10			41,00	80 889 656													
65	40		35	7			10			36,80	80 889 406													●
90	90		35	7			10			46,50	80 889 906													●

## Zachte bek

▲ materiaal: 16MnCr5

▲ prijs per stuk

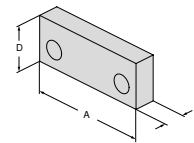

voor basisbreedte	A	A <sub>1</sub>	D	D <sub>1</sub>	D <sub>2</sub>	E	M	M <sub>1</sub>	M <sub>2</sub>	EUR	Y4	NEW	NCG	H5G / -S / -Z	X5G-Z / -S	ESG 4	ESG 5	HDG 2	ZSG 4	ZSG mini	DSG 4	Versto	HSG	
65	65		35				16			41,00	80 889 657													●
65	40		35				16			37,80	80 889 407													●
90	90		35				16			49,70	80 889 907													●

## Basisbek

▲ prijs per stuk

▲ voor Alu bek artikel-nr: 80 914 34200

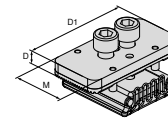

voor basisbreedte	A	A <sub>1</sub>	D	D <sub>1</sub>	D <sub>2</sub>	E	M	M <sub>1</sub>	M <sub>2</sub>	EUR	Y4	NEW	NCG	H5G / -S / -Z	X5G-Z / -S	ESG 4	ESG 5	HDG 2	ZSG 4	ZSG mini	DSG 4	Versto	HSG	
90			9,1	80			40			212,00	80 914 34100													●

## Zachte aluminium bek

▲ prijs per stuk

▲ voor basisbek artikel-nr: 80 914 34100

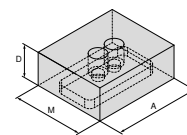

voor basisbreedte	A	A <sub>1</sub>	D	D <sub>1</sub>	D <sub>2</sub>	E	M	M <sub>1</sub>	M <sub>2</sub>	EUR	Y4	NEW	NCG	H5G / -S / -Z	X5G-Z / -S	ESG 4	ESG 5	HDG 2	ZSG 4	ZSG mini	DSG 4	Versto	HSG	
90	90		34,9				75			81,00	80 914 34200													●

## Neertrek-pendelbek, gripvlak

▲ prijs per stuk

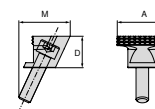

voor basisbreedte	A	A <sub>1</sub>	D	D <sub>1</sub>	D <sub>2</sub>	E	M	M <sub>1</sub>	M <sub>2</sub>	EUR	Y4	NEW	NCG	H5G / -S / -Z	X5G-Z / -S	ESG 4	ESG 5	HDG 2	ZSG 4	ZSG mini	DSG 4	Versto	HSG	
90	40		25				41			105,00	80 914 32600													●

## Overzicht systeembekken

### Neertrekbeek, grip – rond

▲ prijs per stuk

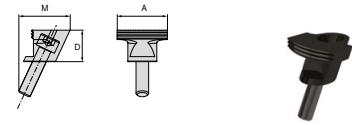

voor basisbreedte	A	A <sub>1</sub>	D	D <sub>1</sub>	D <sub>2</sub>	E	M	M <sub>1</sub>	M <sub>2</sub>
90	40		25				41		

EUR

**NEW**

Y4

118,00

80 914 32700

NCG	H5G / -S / -Z	X5G-Z / -S	ESG 4	ESG 5	HDG 2	ZSG 4	ZSG mini	DSG 4	Versto	HSG
									●	

### Parallelbeek, gripvlak – rond

▲ prijs per stuk

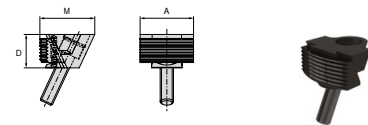

voor basisbreedte	A	A <sub>1</sub>	D	D <sub>1</sub>	D <sub>2</sub>	E	M	M <sub>1</sub>	M <sub>2</sub>
90	40		25				41		

EUR

**NEW**

Y4

219,00

80 914 32800

NCG	H5G / -S / -Z	X5G-Z / -S	ESG 4	ESG 5	HDG 2	ZSG 4	ZSG mini	DSG 4	Versto	HSG
									●	

### Parallelbeek, grip 3 mm

▲ prijs per stuk

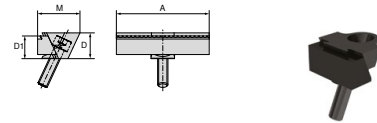

voor basisbreedte	A	A <sub>1</sub>	D	D <sub>1</sub>	D <sub>2</sub>	E	M	M <sub>1</sub>	M <sub>2</sub>
90	40		25	22			41		
90	65		25	22			41		
90	90		25	22			41		

EUR

**NEW**

Y4

175,00

80 914 32900

216,00

80 914 33000

259,00

80 914 33100

NCG	H5G / -S / -Z	X5G-Z / -S	ESG 4	ESG 5	HDG 2	ZSG 4	ZSG mini	DSG 4	Versto	HSG
									●	
									●	
									●	

### Pendelbeek, gripvlak

▲ prijs per stuk

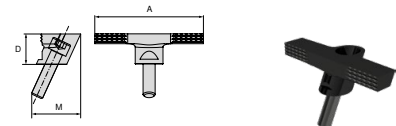

voor basisbreedte	A	A <sub>1</sub>	D	D <sub>1</sub>	D <sub>2</sub>	E	M	M <sub>1</sub>	M <sub>2</sub>
90	90		25				41		

EUR

**NEW**

Y4

182,00

80 914 33200

NCG	H5G / -S / -Z	X5G-Z / -S	ESG 4	ESG 5	HDG 2	ZSG 4	ZSG mini	DSG 4	Versto	HSG
									●	

### Spanspie

▲ prijs per stuk

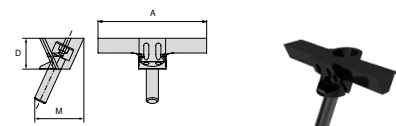

voor basisbreedte	A	A <sub>1</sub>	D	D <sub>1</sub>	D <sub>2</sub>	E	M	M <sub>1</sub>	M <sub>2</sub>
90	90		25				41		

EUR

**NEW**

Y4

200,00

80 914 33300

NCG	H5G / -S / -Z	X5G-Z / -S	ESG 4	ESG 5	HDG 2	ZSG 4	ZSG mini	DSG 4	Versto	HSG
									●	

## Overzicht systeembekken

### Parallelbek, glad

▲ prijs per stuk

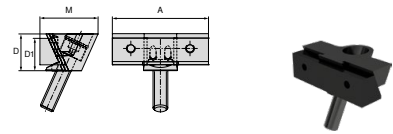

voor basisbreedte	A	A <sub>1</sub>	D	D <sub>1</sub>	D <sub>2</sub>	E	M	M <sub>1</sub>	M <sub>2</sub>	EUR	Y4	NEW	NCG	H5G / -S / -Z	X5G-Z / -S	ESG 4	ESG 5	HDG 2	ZSG 4	ZSG mini	DSG 4	Versto	HSG		
90	40		25	22			41			167,00	80 914 33400														
90	65		25	22			41			271,00	80 914 33500														●
90	90		25	22			41			286,00	80 914 33600														●

### Parallelbek, gripvlak

▲ prijs per stuk

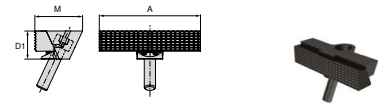

voor basisbreedte	A	A <sub>1</sub>	D	D <sub>1</sub>	D <sub>2</sub>	E	M	M <sub>1</sub>	M <sub>2</sub>	EUR	Y4	NEW	NCG	H5G / -S / -Z	X5G-Z / -S	ESG 4	ESG 5	HDG 2	ZSG 4	ZSG mini	DSG 4	Versto	HSG		
90	90				25		42,5			259,00	80 914 33700														●

### Zachte bek (staal)

▲ materiaal: 16MnCr5

▲ prijs per stuk

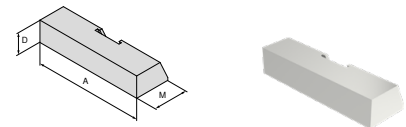

voor basisbreedte	A	A <sub>1</sub>	D	D <sub>1</sub>	D <sub>2</sub>	E	M	M <sub>1</sub>	M <sub>2</sub>	EUR	Y4	NEW	NCG	H5G / -S / -Z	X5G-Z / -S	ESG 4	ESG 5	HDG 2	ZSG 4	ZSG mini	DSG 4	Versto	HSG		
90	90		18				30			83,20	80 914 33800														●

### Zachte bek (aluminium)

▲ prijs per stuk

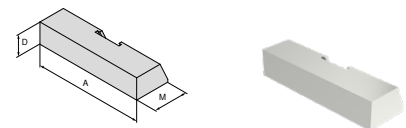

voor basisbreedte	A	A <sub>1</sub>	D	D <sub>1</sub>	D <sub>2</sub>	E	M	M <sub>1</sub>	M <sub>2</sub>	EUR	Y4	NEW	NCG	H5G / -S / -Z	X5G-Z / -S	ESG 4	ESG 5	HDG 2	ZSG 4	ZSG mini	DSG 4	Versto	HSG		
90	90		18				30			83,20	80 914 33900														●

### Adapterplaat, vast

▲ voor opname van 6-voudige bekken

▲ prijs per stuk

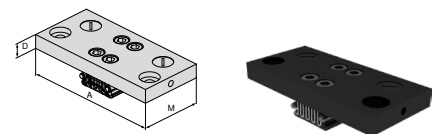

voor basisbreedte	A	A <sub>1</sub>	D	D <sub>1</sub>	D <sub>2</sub>	E	M	M <sub>1</sub>	M <sub>2</sub>	EUR	Y4	NEW	NCG	H5G / -S / -Z	X5G-Z / -S	ESG 4	ESG 5	HDG 2	ZSG 4	ZSG mini	DSG 4	Versto	HSG		
90	160		17				74			453,00	80 914 34000														●



# Overzicht systeembekken

## 6-voudige bek

- ▲ 1 = glad, wolframcarbide gecoat
- ▲ 2 = grip met trap 3 mm
- ▲ 3 = grip met trap 8 mm
- ▲ 4 = grip met trap 18 mm
- ▲ 5 = grip met trap 8 mm
- ▲ 6 = grip rond
- ▲  $M_{max} = 60 \text{ Nm}$
- ▲ incl. bevestigingsbout

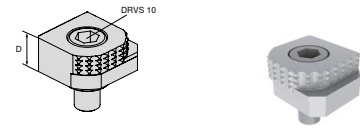

voor basisbreedte	A	A <sub>1</sub>	D	D <sub>1</sub>	D <sub>2</sub>	E	M	M <sub>1</sub>	M <sub>2</sub>	EUR	Y4	NCG	H5G / -S / -Z	X5G-Z / -S	ESG 4	ESG 5	HGG 2	ZSG 4	ZSG mini	DSG 4	Verso	HSG
			18							80,60	80 892 246	●	●	●	●			●		●	●	

## 6-voudige bek

- ▲ 1 = glad
- ▲ 2 = carbide grip
- ▲ 3 = carbide grip met trap 3 mm
- ▲ 4 = carbide grip met trap 8 mm
- ▲ 5 = carbide grip rond met trap 8 mm
- ▲ 6 = carbide grip rond
- ▲ incl. bevestigingsbout

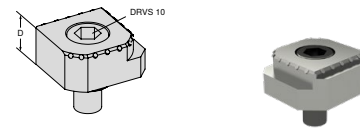

voor basisbreedte	A	A <sub>1</sub>	D	D <sub>1</sub>	D <sub>2</sub>	E	M	M <sub>1</sub>	M <sub>2</sub>	EUR	Y4	NCG	H5G / -S / -Z	X5G-Z / -S	ESG 4	ESG 5	HGG 2	ZSG 4	ZSG mini	DSG 4	Verso	HSG
			18							117,00	80 890 35300	●	●	●	●			●		●	●	

# Overzicht werkstuk onderlegplaten

## Werkstuk onderlegplaten

▲ prijs per 2 stuks

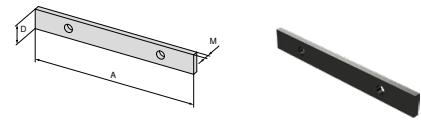

voor basisbreedte	A	A <sub>1</sub>	D	D <sub>1</sub>	D <sub>2</sub>	E	M	M <sub>1</sub>	M <sub>2</sub>
90	90		11				3		

EUR 52,90

NEW

Y4

NCG	H5G / -S / -Z	X5G-Z / -S	ESG 4	ESG 5	HDG 2	ZSG 4	ZSG mini	DSG 4	Verso	HSG
									●	

80 914 73100

## Werkstuk onderlegplaten, getrapt

▲ prijs per 2 stuks

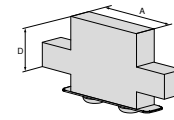

voor basisbreedte	A	A <sub>1</sub>	D	D <sub>1</sub>	D <sub>2</sub>	E	M	M <sub>1</sub>	M <sub>2</sub>
90	40		30						
90	40		25						

EUR 87,40  
87,40

NEW

Y4

NCG	H5G / -S / -Z	X5G-Z / -S	ESG 4	ESG 5	HDG 2	ZSG 4	ZSG mini	DSG 4	Verso	HSG
									●	
									●	

80 914 70200  
80 914 70100

## Werkstuk onderlegplaten, getrapt

▲ prijs per 2 stuks

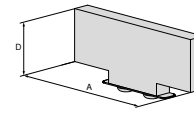

voor basisbreedte	A	A <sub>1</sub>	D	D <sub>1</sub>	D <sub>2</sub>	E	M	M <sub>1</sub>	M <sub>2</sub>
90	65		11						
90	65		17						
90	65		25						
90	65		30						

EUR 87,40  
87,40  
87,40  
87,40

NEW

Y4

NCG	H5G / -S / -Z	X5G-Z / -S	ESG 4	ESG 5	HDG 2	ZSG 4	ZSG mini	DSG 4	Verso	HSG
									●	
									●	
									●	
									●	

80 914 71100  
80 914 71200  
80 914 71300  
80 914 71400

## Werkstuk onderlegplaten, getrapt

▲ prijs per 2 stuks

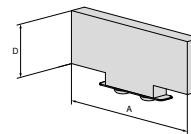

voor basisbreedte	A	A <sub>1</sub>	D	D <sub>1</sub>	D <sub>2</sub>	E	M	M <sub>1</sub>	M <sub>2</sub>
90	90		11						
90	90		17						
90	90		25						
90	90		30						

EUR 87,40  
87,40  
87,40  
87,40

NEW

Y4

NCG	H5G / -S / -Z	X5G-Z / -S	ESG 4	ESG 5	HDG 2	ZSG 4	ZSG mini	DSG 4	Verso	HSG
									●	
									●	
									●	
									●	

80 914 72100  
80 914 72200  
80 914 72300  
80 914 72400

## Overzicht systeem-toebehoren

### Verplaatsbare ondersteuning

- ▲ voor trillingdemping
- ▲ hoogteverstelbaar 16 – 17 mm

Verso

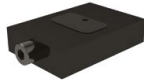
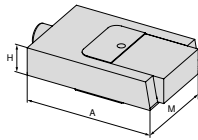

NEW

80 914 ...

EUR  
Y4  
243,00 50100

H mm	A mm	M mm
16	72	50

### Opspanbouten set voor T-sleuf

- leveromvang:  
cilinderkopschoef en T-moer

Verso



NEW

80 914 ...

EUR  
Y4  
42,20 50500  
49,70 50600  
60,50 50700

voor gleuf-breedte mm	G
20	M12
22	M12
24	M12

### Ondersteuning

- ▲ voor trillingdemping: Artikel-nr. 80 914 50100

Verso

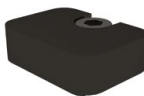
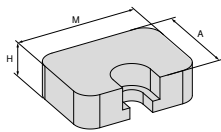

NEW

80 914 ...

EUR  
Y4  
62,70 50200  
62,70 50300

H mm	A mm	M mm
8	20	28
13	20	28

### Uitrichtpennen

Verso



NEW

80 914 ...

EUR  
Y4  
107,00 81400  
107,00 81600  
107,00 81800

D <sub>1</sub> mm	D <sub>2</sub> mm
12	14
12	16
12	18

### Verbindingsstuk

- ▲ voor het verbinden van basisrails

Verso

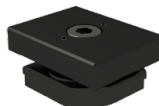
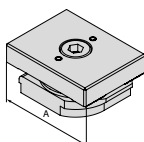

NEW

80 914 ...

EUR  
Y4  
183,00 50400

A mm
90

### Afdekstrip

Verso

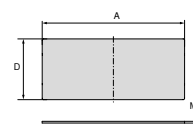

NEW

80 914 ...

EUR  
Y4  
15,80 51000  
6,80 50800  
10,10 50900

A mm	D mm	M mm
50	84	0,5
50	86	0,5
200	86	0,5

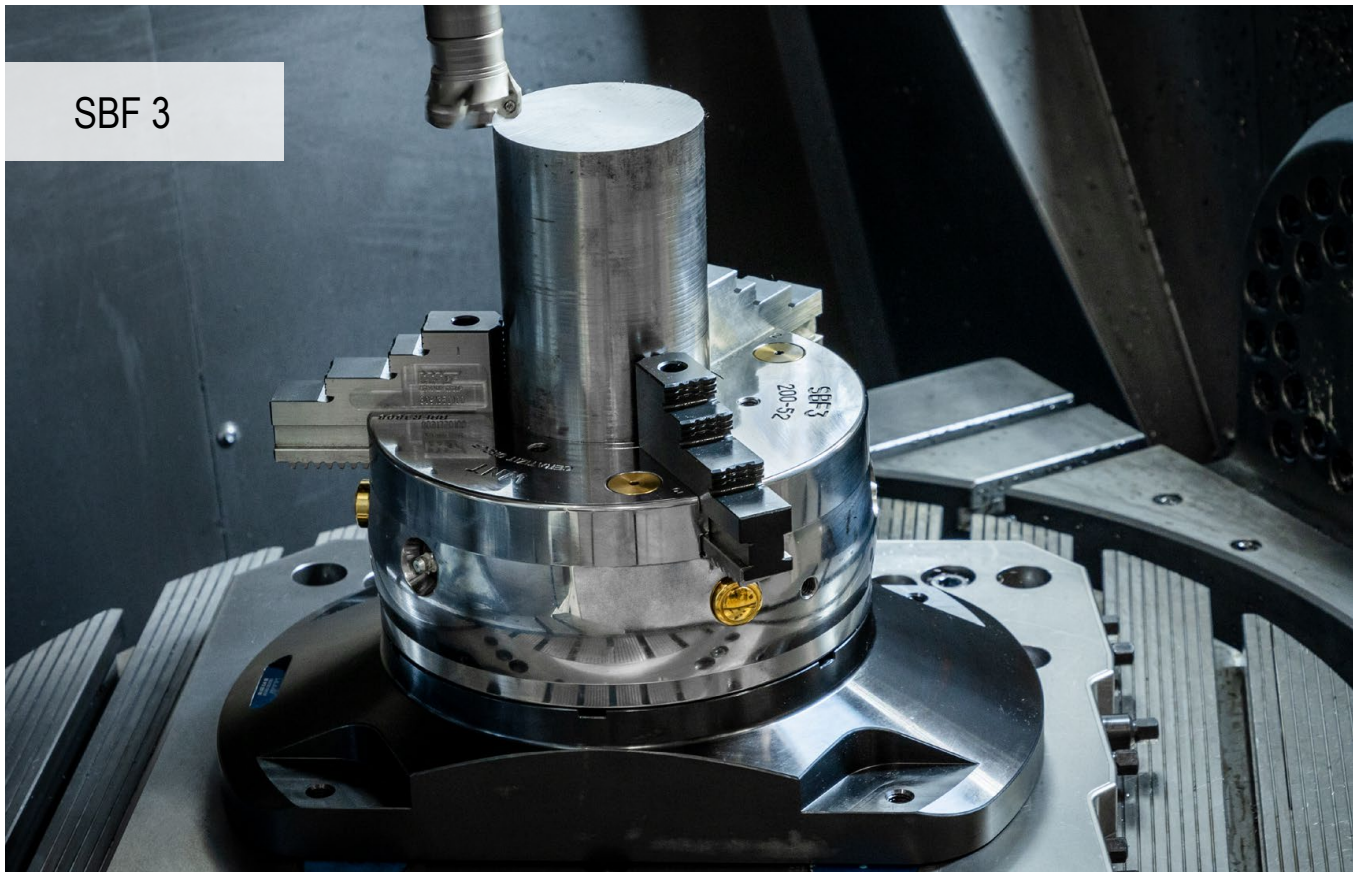

## Met spanning verwacht – efficiënt spannen op rond materiaal

Het bewerken van rond materiaal is inmiddels gewoon geworden. Met de stationaire 3-klawwplaat SBF 3 hebben we nu een oplossing in het programma – volledig passend onze eigen PNG en MNG nulpuntspansystemen voor een snelle en gemakkelijke gebruik.

### Uw voordelen:

- ▲ bijzonder geschikt voor gebruik op een (3/5-assige) freesmachine en ronde werkstukken
- ▲ passend op PNG- en MNG-nulpuntspansystemen
- ▲ bekken snelwissel-systeem met onafhankelijk verwisselbare bekken
- ▲ spindel via zeskant aansluiting



SBF 3 Ø 200 mm

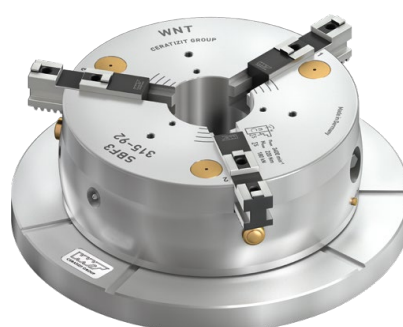

SBF 3 Ø 315 mm

## Technische informatie – doorsnede

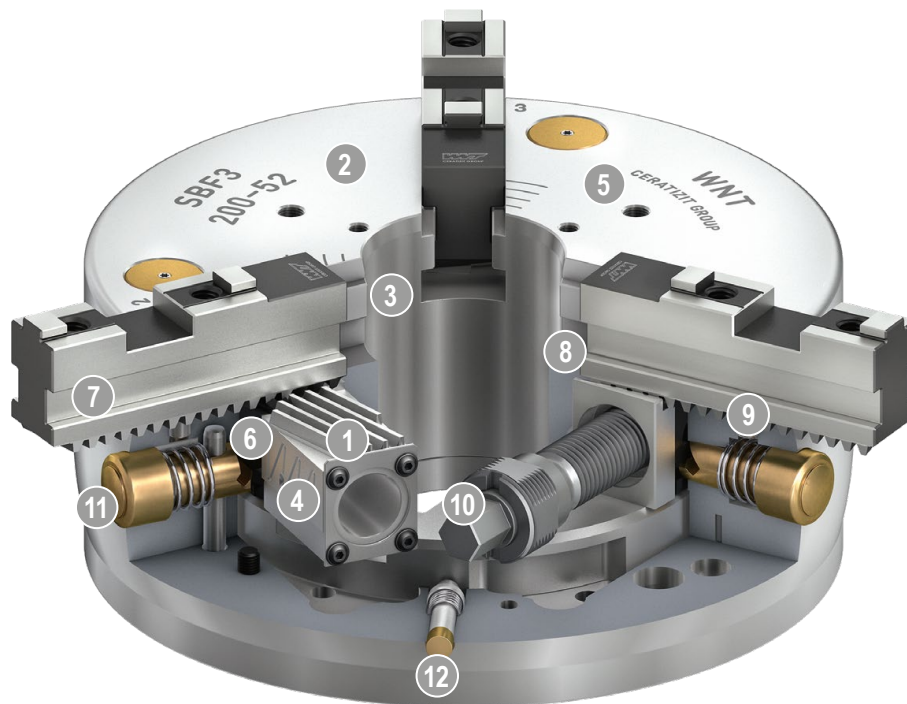

- |  |   |
|--|---|
| <p>1 <b>Spiestang-systeem</b><br/>maakt uitstekende bewerkingsresultaten mogelijk</p>  | <p>7 <b>Grondbekken met schuine vertanding (SGF)</b></p>  |
| <p>2 <b>Geharde en extreem stijve klauwplaat</b><br/>daardoor een lange levensduur met de hoogste precisie – ook bij de hoogste spankracht</p> | <p>8 <b>Vergrendelingsmechanisme</b><br/>garandeert betrouwbaar ingrijpen van de vertanding</p> |
| <p>3 <b>Grote doorvoer boring</b><br/>voor de verwerking van veelvoorkomend stafmateriaal (optioneel: vergroting van de doorvoer boring)</p>   | <p>9 <b>Plunjerpen</b><br/>voor het voor-positioneren van de (grond)bekken</p>                  |
| <p>4 <b>Geoptimaliseerd smeersysteem</b><br/>voor hoge efficiëntie</p>   | <p>10 <b>Aandraaien via standaard zeskant</b><br/>dit zorgt voor een eenvoudige bediening</p>   |
| <p>5 <b>Montagegaten</b><br/>voor bijv. een aanslag voor korte werkstukken</p>   | <p>11 <b>Drukknop voor bekkenwissel</b><br/>voor korte omsteltijden</p>                         |
| <p>6 <b>Bekken snelwissel-systeem</b><br/>de onafhankelijk verwisselbare bekken maken korte omsteltijden mogelijk</p>                          | <p>12 <b>Indicatie stift</b><br/>voor een visuele controle van de slag van de klauwplaat</p>    |

## SBF 3 klauwplaat (Ø 200 mm) met spanplaat

- ▲ bijzonder geschikt voor gebruik op een (3/5-assige) freesmachine met ronde werkstukken
- ▲ passend op PNG- en MNG-nulpuntspansystemen (nulpuntspansystemen apart bestellen)
- ▲ bekken snelwissel-systeem met onafhankelijk verwisselbare bekken
- ▲ Spindel via zeskant aansluiting

### leveromvang:

SBF 3 klauwplaat (Ø 200 mm) incl. spanplaat (PNG en MNG voorbereid)  
1 set grondbekken GBA  
1 set getrapte harde bekken SB-H  
6 bevestigingsschroeven en spansleutel

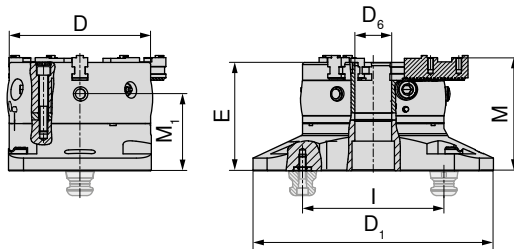

D	D <sub>1</sub>	D <sub>6</sub>	E	I	M	M <sub>1</sub>	MXC	TQX	DRVS	Slag	Steek	WT
mm	mm	mm	mm	mm	mm	mm	kN	Nm	mm	mm	mm	kg
200	340	52	153,3	200	160,1	108,8	100	120	12	7	4,8	49,5

80 913 ...

EUR  
Y4

3.964,00 20000

## SBF 3 klauwplaat (Ø 315 mm) met spanplaat

- ▲ bijzonder geschikt voor gebruik op een (3/5-assige) freesmachine met ronde werkstukken
- ▲ passend op PNG- en MNG-nulpuntspansystemen (nulpuntspansystemen apart bestellen)
- ▲ bekken snelwissel-systeem met onafhankelijk verwisselbare bekken
- ▲ Spindel via zeskant aansluiting

### leveromvang:

SBF 3 klauwplaat (Ø 315 mm) incl. spanplaat (PNG en MNG voorbereid)  
1 set grondbekken GBA  
1 set getrapte harde bekken SB-H  
6 bevestigingsschroeven en spansleutel

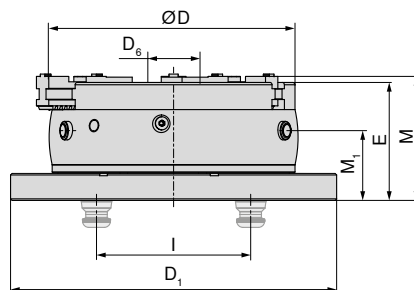

D	D <sub>1</sub>	D <sub>6</sub>	E	I	M	M <sub>1</sub>	MXC	TQX	DRVS	Slag	Steek	WT
mm	mm	mm	mm	mm	mm	mm	kN	Nm	mm	mm	mm	kg
315	423	92	153	200	160,86	90,5	180	220	16	9,9	7	95

80 913 ...

EUR  
Y4

6.537,00 31500



De klauwplaat is uitsluitend ontworpen voor stationair gebruik – niet voor draaibewerkingen gebruiken!

## Overzicht systeembekken

## Grondbekken (GBA) – set

- ▲ grondbekken met schuine vertanding
- ▲ prijs per set van 3 stuks

## leveromvang:

3 grondbekken met schuine vertanding  
inclusief cilinderkopschroeven

SBF  
3

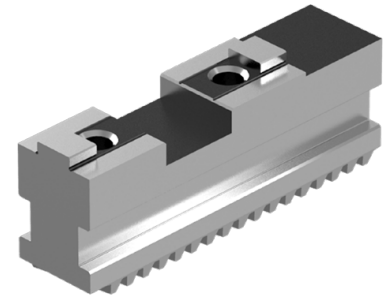
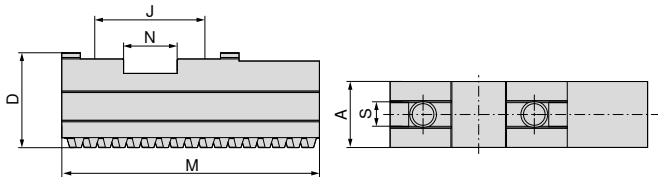

voor	A	D	J	M	N	S	G	WT
	mm	mm	mm	mm	mm	mm		kg
SBF-3.200	22	32	40	90	20	10	M8x1	1,2
SBF-3.315	32	43	54	125	26	12	M12x1,5	3,1

80 913 ...

EUR  
Y4242,00 50300  
400,00 60300

## Zachte opzetbekken (AB-W) – set

- ▲ prijs per set van 3 stuks
- ▲ Materiaal: 16MnCr5

## leveromvang:

3 zachte opzetbekken

SBF  
3

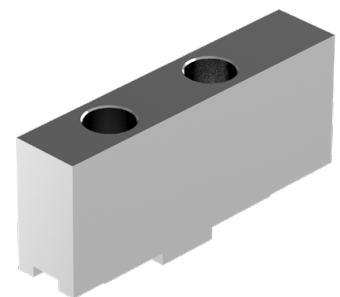
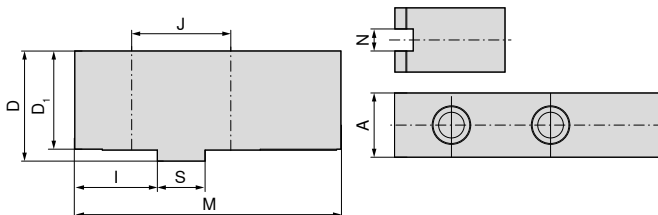

voor	A	D	D <sub>1</sub>	I	J	M	N	S	Boring voor	WT
	mm	mm	mm	mm	mm	mm	mm	mm		kg
SBF-3.200	22	47	43	35	40	105	10	20	M8	2,0
SBF-3.315	35	60	54	45	54	145	12	26	M12	5,6

80 913 ...

EUR  
Y447,30 50400  
98,20 60400

## Overzicht systeembekken

### Getrapte harde opzetbekken (AB-H) – set

▲ prijs per set van 3 stuks

**leveromvang:**

3 getrapte harde opzetbekken

**SBF  
3**

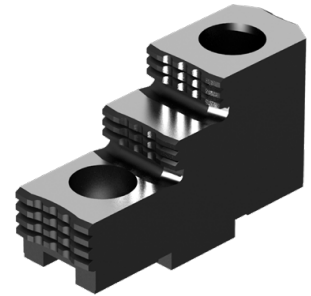
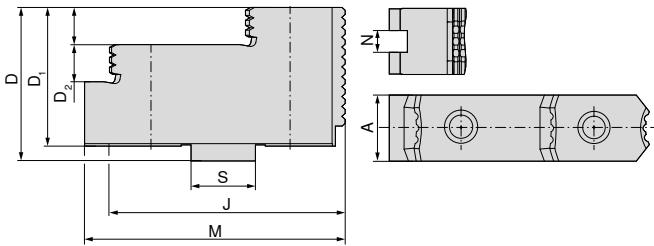

**80 913 ...**

voor	A mm	D mm	D <sub>1</sub> mm	D <sub>2</sub> mm	J mm	M mm	N mm	S mm	Boring voor	WT kg
SBF-3.200	22	42	38	10	40	71,7	10	20	M8	2,4
SBF-3.315	36	62	56	15	54	105	12	26	M12	3,3

EUR  
Y4

207,00 50200  
303,00 60200

### Maattabel – Getrapte harde opzetbekken (AB-H)

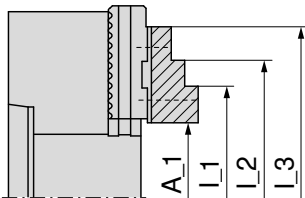

Stellen van de grondbekken 2

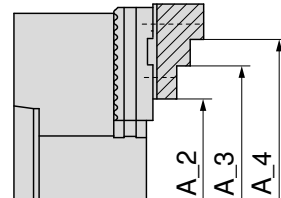

Stellen van de grondbekken 1

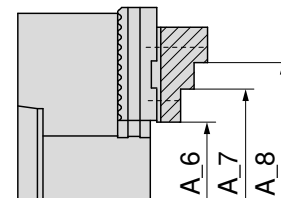

Stellen van de grondbekken 2

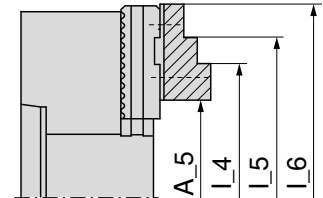

Stellen van de grondbekken 1

3-klawwplaat	Systeembekken	Spannen van buitenaf							
		A_1	A_2	A_3	A_4	A_5	A_6	A_7	A_8
SBF-3.200	<b>80 913 50200</b> SBF-3.AB-H.200.71.7.22.10	7-76	57-125	108-177	135-204	55-125	14-77	66-129	93-156
SBF-3.315	<b>80 913 60200</b> SBF-3.AB-H.315.105.36.15	14-125	93-224	202-333	-	87-219	44-130	153-239	-

3-klawwplaat	Systeembekken	Spannen van binnenuit					
		I_1	I_2	I_3	I_4	I_5	I_6
SBF-3.200	<b>80 913 50200</b> SBF-3.AB-H.200.71.7.22.10	72-141	99-168	151-220	120-189	147-216	199-268
SBF-3.315	<b>80 913 60200</b> SBF-3.AB-H.315.105.36.15	93-204	202-313	-	167-298	276-407	-



## Overzicht systeembekken

### Getrapte harde bekken (SB-H) – set

- ▲ getrapte harde opzetbekken met schuine vertanding
- ▲ prijs per set van 3 stuks

**leveromvang:**

3 getrapte harde bekken

**SBF**  
**3**

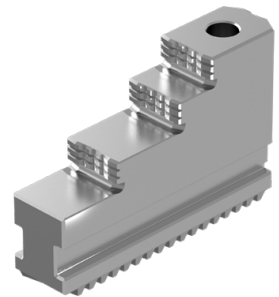
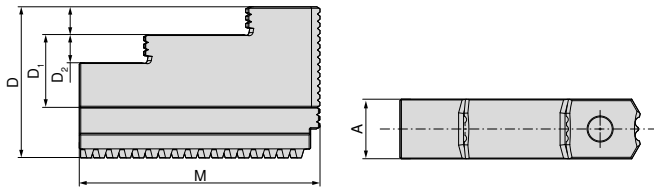

voor	A	D	D <sub>1</sub>	D <sub>2</sub>	M	WT
	mm	mm	mm	mm	mm	kg
SBF-3.200	22	60	35	10	94	1,9
SBF-3.315	32	81	46	15	129	5,5

**80 913 ...**

EUR  
Y4  
420,00 50100  
661,00 60100

### Maattabel – Getrapte harde bekken (SB-H)

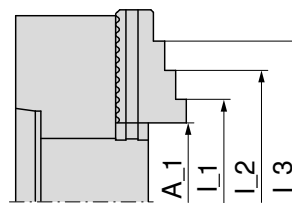

Getrapte harde bekken  
Staal 16MnCr5, oppervlakte gehard

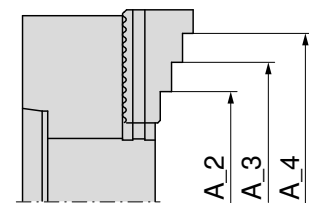

Getrapte harde bekken  
Staal 16MnCr5, oppervlakte gehard

3-klawplaat	Systeembekken	Spannen van buitenaf				Spannen van binnenuit		
		A_1	A_2	A_3	A_4	L_1	L_2	L_3
SBF-3.200	<b>80 913 50100</b> SBF-3.SB-H.200.94.22.10	6–74	59–128	111–180	138–207	70–138	97–165	149–217
SBF-3.315	<b>80 913 60100</b> SBF-3.SB-H.315.129.32.15	12–124	89–210	189–420	–	91–203	199–311	–

## Handmatige machineklem

- ▲ handige, universele klem met groot spanbereik
- ▲ bekken met trap alsmede met horizontaal en verticaal prisma 120°
- ▲ optionele materiaal aanslag aan beide zijden in te zetten

HSG

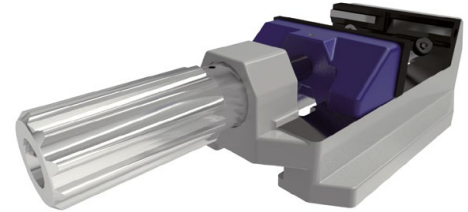
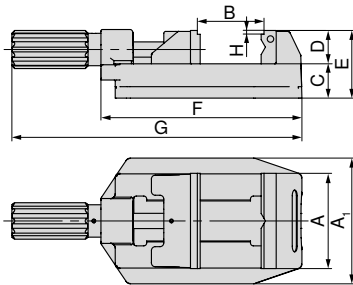

A	A <sub>1</sub>	B	C	D	E	F	G	H	WT
mm	mm	mm	mm	mm	mm	mm	mm	mm	kg
80	112	0 - 81	36	35	71	194	286,5	4	4,5
100	132	0 - 100	36	35	71	211	304,5	4	5,6
125	156	0 - 131	40	40	84	274	386	4	11,2

80 893 ...

EUR

Y4

286,00 080

303,00 100

506,00 125

## Handmatige machineklem met spanhulp

- ▲ veilig en snel werkstuk spannen met de spanhulp
- ▲ handige, universele klem met groot spanbereik
- ▲ bekken met trap alsmede met horizontaal en verticaal prisma 120°
- ▲ optionele materiaal aanslag aan beide zijden in te zetten
- ▲ N = spanweg bij hendelspanning

HSG

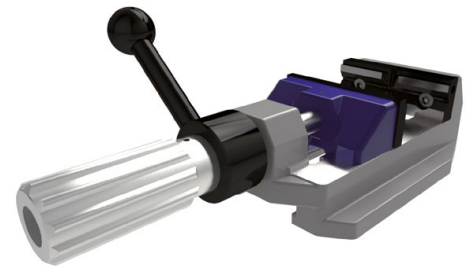
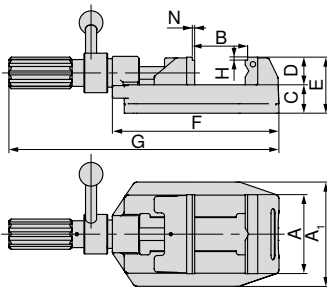

A	A <sub>1</sub>	B	C	D	E	F	G	H	N	WT
mm	mm	mm	mm	mm	mm	mm	mm	mm	mm	kg
100	132	0 - 100	36	35	71	211	342	4	1,5	6,1
125	156	0 - 133	44	40	84	274	405	4	1,5	11,7

80 893 ...

EUR

Y4

491,00 101

702,00 126

### Klemmengids

Systeem-toebehoren

132+133

Algemeen toebehoren

164-183

## Overzicht opzetbekken

### Getrapte bek, glad

▲ prijs per stuk

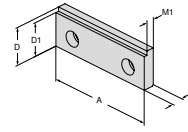

voor basisbreedte	A	A <sub>1</sub>	D	D <sub>1</sub>	D <sub>2</sub>	E	M	M <sub>1</sub>	M <sub>2</sub>	EUR	Y4	NCG	H5G / -S / -Z	X5G-Z / -S	ESG 4	ESG 5	HDG 2	ZSG 4	ZSG mini	DSG 4	Verso	HSG		
80			35	31			10,2	7,2		49,00	80 893 082												●	
100			35	31			10,2	7,2		45,00	80 893 102													●
125			40	36			11,8	8,8		58,00	80 893 127													●

### Getrapte bek 17 mm

▲ prijs per stuk

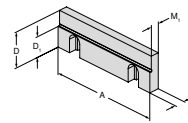

voor basisbreedte	A	A <sub>1</sub>	D	D <sub>1</sub>	D <sub>2</sub>	E	M	M <sub>1</sub>	M <sub>2</sub>	EUR	Y4	NCG	H5G / -S / -Z	X5G-Z / -S	ESG 4	ESG 5	HDG 2	ZSG 4	ZSG mini	DSG 4	Verso	HSG		
125			40	23			11,5	9,5		123,00	80 892 244													●

### Prisma bek

▲ prismabek met horizontaal en verticaal prisma

▲ prijs per stuk

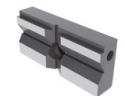
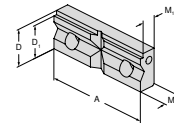

voor spandiameter	A	A <sub>1</sub>	D	D <sub>1</sub>	D <sub>2</sub>	E	M	M <sub>1</sub>	M <sub>2</sub>	EUR	Y4	NCG	H5G / -S / -Z	X5G-Z / -S	ESG 4	ESG 5	HDG 2	ZSG 4	ZSG mini	DSG 4	Verso	HSG			
9 - 31	80		35	31			15,8	12,8		58,00	80 893 083													●	
9 - 31	100		35	31			15,8	12,8		74,00	80 893 103														●
11 - 41	125		40	36			17,8	14,8		129,00	80 893 128														●

→ pagina 164-173  
Hier vindt u verdere geschikte opzetbekken.

## Overzicht systeem-toebehoren

### Werkstukaanslag

- ▲ wordt aan vast deel bevestigd, naar keuze links, rechts of aan beide zijden.
- De lengteverstelling wordt snel en nauwkeurig met een klemschroef uitgevoerd.

HSG



80 893 ...

EUR  
Y4

46,00 265

voor breedte  
mm

80/100/125

### Geleiderail

- ▲ voorkomt ongelukken
- ▲ verhindert ongewenst meedraaien en optillen

HSG

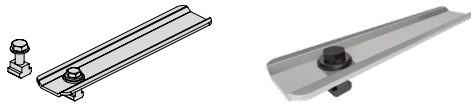

80 893 ...

EUR  
Y4

50,00 260

voor breedte  
mm

80/100/125

### Opspan set

- ▲ door een verschuifbare steun met excentrisch zwenkbare lagering kan elke positie op een machinetafel met T-gleuven worden verkregen. Een tweede bevestigingsmogelijkheid is, zoals bij de geleiderail 80 893 260, via de gleuf in de basis van de klem.
- ▲ prijs per set

leveromvang:

2 positioneer-klemvingers incl. opspantoebehoren

HSG



80 893 ...

EUR  
Y4

132,00 250

voor breedte  
mm

80/100/125

voor gleuf-breedte  
mm

12/14

## Overzicht MNG en PNG nulpuntspansysteem

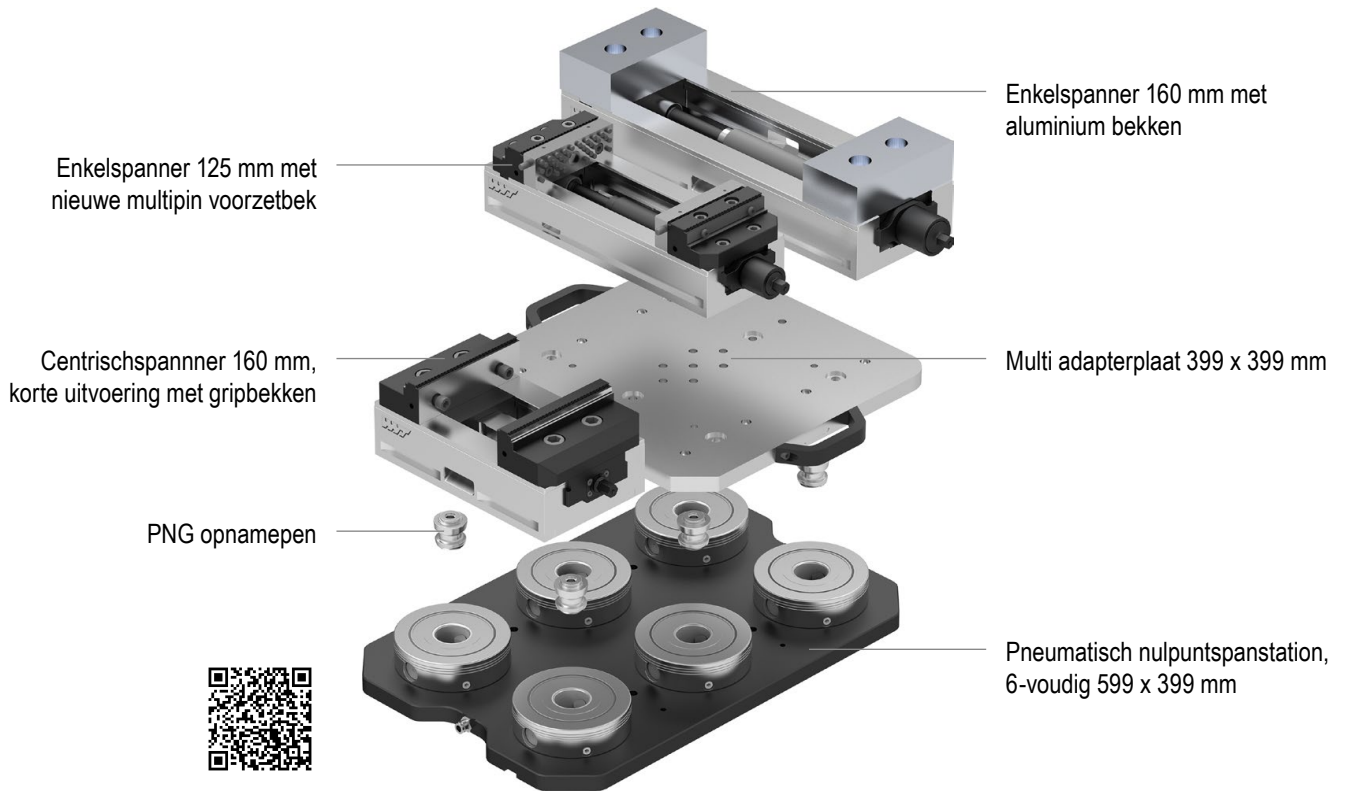

## MNG – Grondplaat rond

- ▲ MNG – Mechanisch nulpuntspansysteem
- ▲ gehard en geslepen
- ▲ repetiteernauwkeurigheid  $\leq 0,01$  mm
- ▲ aantrekkkracht 20 kN
- ▲ aantrekmoment 30 Nm

MNG

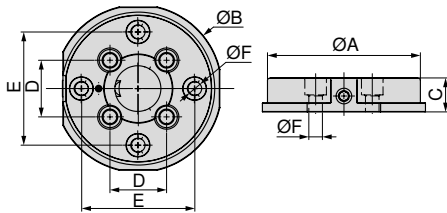

A	B	C <sub>+0,005</sub>	D	E	F <sub>H7</sub>	WT
mm	mm	mm	mm	mm	mm	kg
135	148	30	50	100	12	3,5

80 899 ...

EUR  
Y4  
571,00 125

Klemmengids

Systeem-toebehoren

144+145 Algemeen toebehoren

164-183

## MNG – Rechthoekige grondplaat

- ▲ MNG – Mechanisch nulpuntspansysteem
- ▲ aantrekkkracht steeds 20 kN aan spanpen
- ▲ roestvrij en vacuümgehard
- ▲ repeteernauwkeurigheid  $\leq 0,01$  mm
- ▲ aantrekmoment 30 Nm

MNG

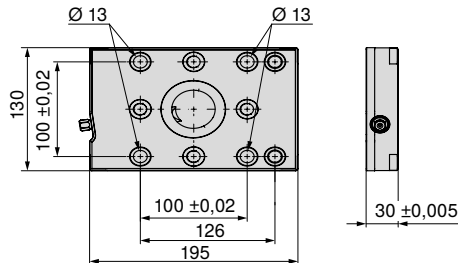

80 899 ...

EUR  
Y4

702,00 65000

grootte	WT kg
195x130 mm	5,2

## MNG – Rechthoekige 2 voudige grondplaat

- ▲ MNG – Mechanisch nulpuntspansysteem
- ▲ aantrekkkracht steeds 20 kN aan spanpen
- ▲ roestvrij en vacuümgehard
- ▲ repeteernauwkeurigheid  $\leq 0,01$  mm
- ▲ aantrekmoment 30 Nm

MNG

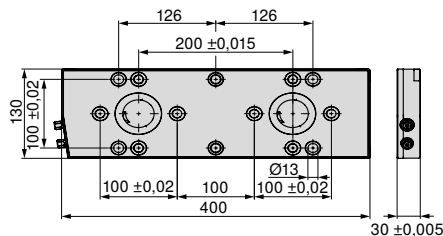

80 899 ...

EUR  
Y4

1.650,00 65100

grootte	WT kg
400x130 mm	11

### Klemmengids

Systeem-toebehoren	144+145	Algemeen toebehoren	164-183
MNG-opspanmogelijkheden	146-148		

## MNG – Rechthoekige 3 voudige grondplaat

- ▲ MNG – Mechanisch nulpuntspansysteem
- ▲ aantrekkkracht steeds 20 kN aan spanpen
- ▲ roestvrij en vacuümgehard
- ▲ repeteernauwkeurigheid  $\leq 0,01$  mm
- ▲ aantrekmoment 30 Nm

MNG

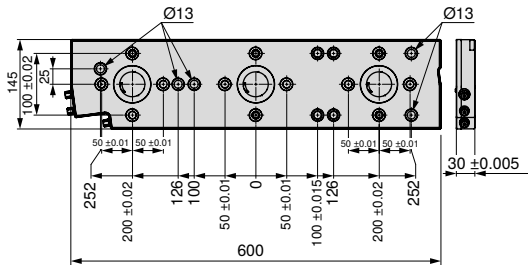

80 899 ...

EUR  
Y4

2.340,00 65200

grootte	WT
	kg
600x145 mm	18

## MNG – Grondplaat 3-voudig, 270 x 190 mm

- ▲ MNG – Mechanisch nulpuntspansysteem
- ▲ aantrekkkracht steeds 20 kN aan spanpen
- ▲ 4 x bevestigingsgaten voor M12, voor T-gleuf afstand 50 mm
- ▲ 8 x rasterbussen Ø12 F7/M12
- ▲ 4 x pasgaten Ø18 H7 voor positionering

MNG

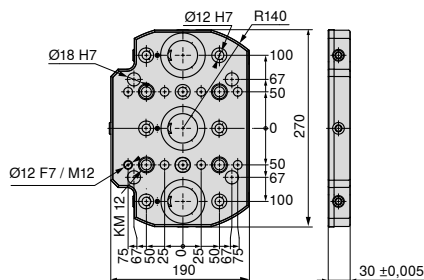

80 899 ...

EUR  
Y4

2.110,00 230

grootte	WT
	kg
270x190 mm	9

### Klemmengids

Systeem-toebehoren	144+145	Algemeen toebehoren	164–183
MNG-opspanmogelijkheden	146–148		

## MNG – Grondplaat 4-voudig, 330 x 400 mm

- ▲ MNG – Mechanisch nulpuntspansysteem
- ▲ aantrekkkracht steeds 20 kN aan spannen
- ▲ 15 x bevestigingsgaten voor M12 voor T-gleuf afstand 50, 63, 100, 125 mm
- ▲ 13 x pasgaten Ø12 F7/M12
- ▲ 2 x pasgaten Ø18 G7 voor positionering
- ▲ 1 x pasgat Ø12 F7 voor positionering

MNG

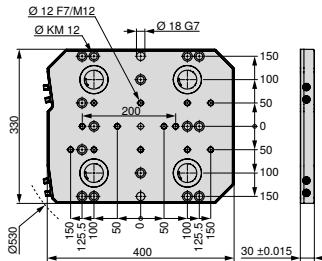

80 899 ...

EUR  
Y43.290,00 63000<sup>1)</sup>

grootte	WT
330x400 mm	28 kg

1) geen voorraadartikel

## MNG – Grondplaat 6-voudig, 400 x 400 mm

- ▲ MNG – Mechanisch nulpuntspansysteem
- ▲ aantrekkkracht steeds 20 kN aan spannen
- ▲ 14 x bevestigingsgaten voor M16 voor T-gleuf afstand 63, 80, 100, 125 mm
- ▲ 2 x bevestigingsgaten voor M12
- ▲ 17 x pasgaten Ø12 F7/M12
- ▲ 2 x pasgaten Ø18 G7 voor positionering
- ▲ 1 x pasgat Ø12 F7 voor positionering

MNG

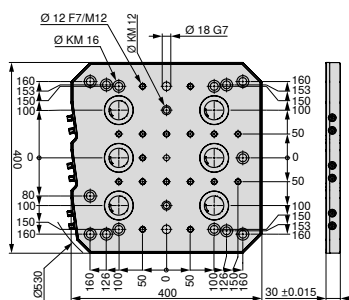

80 899 ...

EUR  
Y44.510,00 63100<sup>1)</sup>

grootte	WT
400x400 mm	33 kg

1) geen voorraadartikel

### Klemmengids

Systeem-toebehoren

144+145 Algemeen toebehoren

164–183



## MNG – Grondplaat 6-voudig, 400 x 530 mm

- ▲ MNG – Mechanisch nulpuntspansysteem
- ▲ aantrekkkracht steeds 20 kN aan spannen
- ▲ 24 x bevestigingsgaten voor M12 voor T-gleuf afstand 63, 100, 125 mm
- ▲ 21 x pasgaten  $\varnothing 12$  F7/M12
- ▲ 2 x pasgaten  $\varnothing 18$  G7 voor positionering
- ▲ 1 x pasgat  $\varnothing 12$  F7 voor positionering

MNG

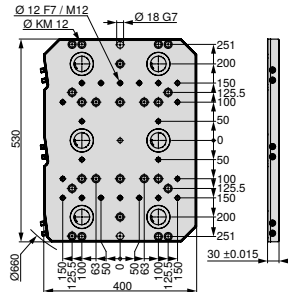

80 899 ...

EUR  
Y44.880,00 63200<sup>1)</sup>

grootte	WT kg
400x530 mm	45

1) geen voorraadartikel

## MNG – Grondplaat 10-voudig, 496,5 x 532 mm

- ▲ MNG – Mechanisch nulpuntspansysteem
- ▲ aantrekkkracht steeds 20 kN aan spannen
- ▲ 27 x bevestigingsgaten voor M12 voor T-gleuf afstand 50, 63, 100, 125 mm en stergleuven 45°
- ▲ 20 x pasgaten  $\varnothing 12$  F7/M12
- ▲ 2 x pasgaten  $\varnothing 18$  G7 voor positionering
- ▲ 1 x pasgat  $\varnothing 12$  F7 voor positionering

MNG

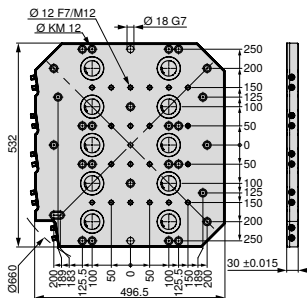

80 899 ...

EUR  
Y46.930,00 63300<sup>1)</sup>

grootte	WT kg
497x532 mm	54

1) geen voorraadartikel

## Klemmengids

Systeem-toebehoren

144+145 Algemeen toebehoren

164–183

## MNG – Centreerpen

▲ MNG – Mechanisch nulpuntspansysteem

MNG

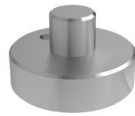

80 899 ...

D <sub>1</sub> n6 mm	D <sub>2</sub> h6 mm	EUR Y4	
12	30	74,00	61700
12	32	73,50	61800
12	50	39,00	61900

## MNG – Uitrichtpen

▲ MNG – Mechanisch nulpuntspansysteem

MNG



80 899 ...

D <sub>1</sub> n6 mm	D <sub>2</sub> h6 mm	EUR Y4	
18	14	46,50	607
18	18	46,50	608
18	20	61,50	609
18	22	61,50	610

## MNG – Opspanbouten set voor T-gleuf

▲ MNG – Mechanisch nulpuntspansysteem

leveromvang:

Opspanbouten en T-moeren

MNG



80 899 ...

voor gleuf-breedte mm	G	EUR Y4	
12	M8	31,10	63800
12	M10	11,50	63400
14	M8	31,10	63900
14	M12	13,80	63500 <sup>1)</sup>
16	M8	31,10	64000
16	M12	13,80	63600 <sup>1)</sup>
18	M8	31,10	64100
18	M12	13,80	63700 <sup>1)</sup>

1) met bouten met lage kop

## MNG – Console met nulpunt spanplaat

- ▲ MNG – Mechanisch nulpuntspansysteem
- ▲ universeel op alle machinetafels in te zetten
- ▲ aantrekkraft 20 kN

### leveromvang:

Console inclusief ronde MNG spanplaat

MNG

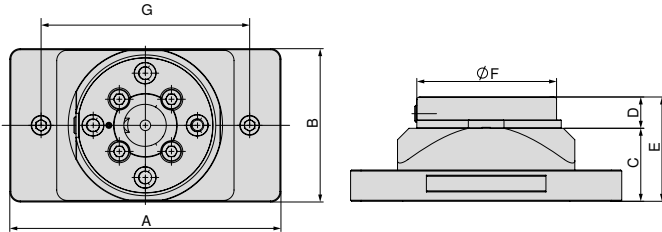

A	B	C	D	E	F	G	WT
mm	mm	mm	mm	mm	mm	mm	kg
260	147	70	30	100	135	200	8,9

80 899 ...

EUR  
Y4

1.080,00 425

## MNG – Console

- ▲ MNG – Mechanisch nulpuntspansysteem
- ▲ universeel op alle machinetafels in te zetten
- ▲ materiaal: hardgeanodiseerd aluminium

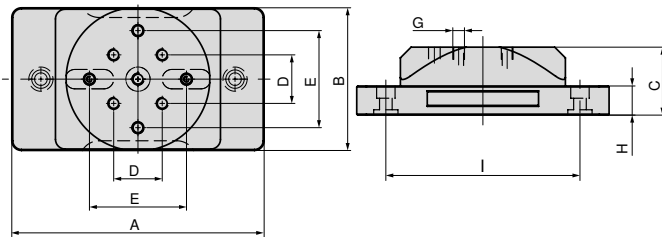

A	B	C	D	E <sub>±0,02</sub>	G	H	I	WT
mm	mm	mm	mm	mm	M12	mm	mm	kg
260	147	70	50	100	M12	30	200	5,5

80 899 ...

EUR  
Y4

519,00 420

### Klemmengids

Systeem-toebehoren

144+145 Algemeen toebehoren

164–183

## MNG – Dubbele console met nulpunt spanplaat

- ▲ MNG – Mechanisch nulpuntspansysteem
- ▲ universeel op alle machines inzetbaar
- ▲ materiaal: hardgeanodiseerd aluminium

### leveromvang:

Console inclusief ronde MNG spanplaat

MNG

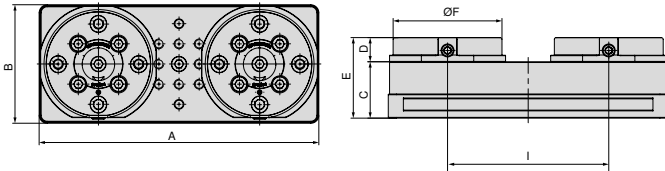

A	B	C	D	E	F	I	WT
mm	mm	mm	mm	mm	mm	mm	kg
347	147	70	30	100	135	200	16,5

80 899 ...

EUR  
Y4

1.950,00 435

## MNG – Dubbele console

- ▲ MNG – Mechanisch nulpuntspansysteem
- ▲ universeel op alle machines inzetbaar
- ▲ materiaal: hardgeanodiseerd aluminium

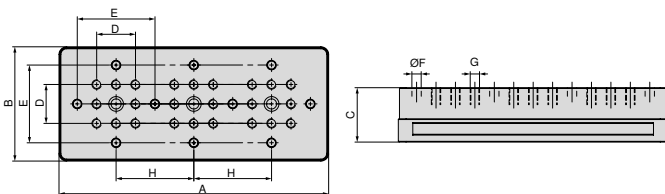

A	B	C	D	E ±0,02	F F7	G	H	WT
mm	mm	mm	mm	mm	mm	M12	mm	kg
347	147	70	50	100	12	M12	100	9,3

80 899 ...

EUR  
Y4

709,00 430

### Klemmengids

Systeem-toebehoren

144+145 Algemeen toebehoren

164–183

## MNG – Console met nulpunt spanplaat

▲ MNG – Mechanisch nulpuntspansysteem

MNG

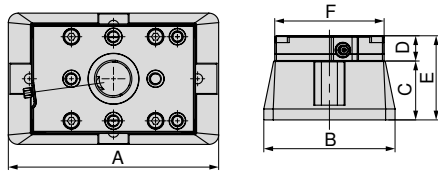

A	B	C	D	E	F
mm	mm	mm	mm	mm	mm
250	156	70	30	100	130

80 878 ...

EUR  
Y4  
1.300,00 54000

## Console

▲ MNG – Mechanisch nulpuntspansysteem

ZSG  
4

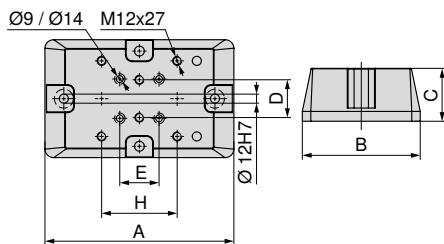

A	B	C	D	E	H	voor
mm	mm	mm	mm	mm	mm	
250	156	70	50	52	100	ZSG 4 - 80 L = 130 mm + 190 mm / ZSG 4 - 125 L = 160 mm
320	197	100	50	50	100	ZSG 4 - 160 L = 280 mm
340	162	100	50	50	100	ZSG 4 - 125 L = 235 mm / 300 mm

80 878 ...

EUR  
Y4  
573,00 54100  
903,00 54400  
900,00 54300

## MNG – Montageset voor console

▲ MNG – Mechanisch nulpuntspansysteem



voor
ZSG-4.125/160.L235-L280
ZSG-4.80.L130-L190

80 878 ...

EUR  
Y4  
11,30 54500  
11,30 54200

Klemmengids

Systeem-toebehoren

144+145 Algemeen toebehoren

164-183

# MNG – Aluminium vormspantang

- ▲ MNG – Mechanisch nulpuntspansysteem
- ▲ voor het infrezen van vormen voor bewerking van 2<sup>e</sup> zijde

**leveromvang:**

spantang met positioneerstiften, zonder bevestigingsbout

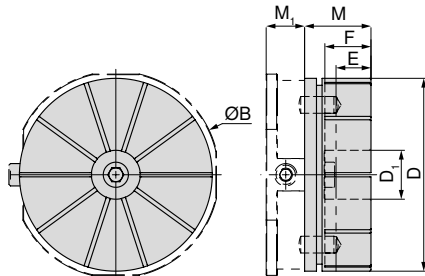

B	D	D <sub>1</sub>	E	F	M	M <sub>1</sub>
mm	mm	mm	mm	mm	mm	mm
148	138	35	22	33	47,5	27,5

**80 899 ...**  
EUR  
Y4  
240,00 500

Op aanvraag verkrijgbaar



Alu-spantang met ingewerkte  
werkstukvorm op MNG rond



Alu-spantang met ingespannen  
werkstuk op MNG rond



raster-pallet



pallet blank

 De maximale uitfreesdiepte E bedraagt 22 mm

## Instelring voor MNG vormspantang

MNG



**80 899 ...**  
EUR  
Y4  
58,30 510

*Klemmengids*

Systeem-toebehoren

144+145

Algemeen toebehoren

164-183

## MNG – opnamepen

▲ MNG – Mechanisch nulpuntspansysteem

leveromvang:

zonder bevestigingsbouten

MNG

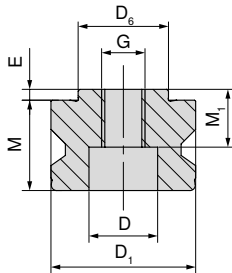

D <sub>6</sub> h6	D <sub>1</sub> h6	M	M <sub>1</sub>	E	D	G
mm	mm	mm	mm	mm	mm	
25	40	27	17	3	19	M12

80 899 ...

EUR  
Y4  
48,60 025

## MNG – Afdichtstop

▲ MNG – Mechanisch nulpuntspansysteem

MNG

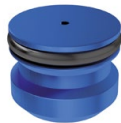

D <sub>1</sub>
mm
40

80 899 ...

EUR  
Y4  
14,30 040

## MNG – paspen-set

▲ MNG – Mechanisch nulpuntspansysteem

▲ voor ESG mini 4V toren en direct spannen van werkstukken

▲ prijs per 2 stuks

MNG

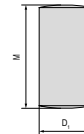

D <sub>1</sub> m6	M
mm	mm
12	24

80 899 ...

EUR  
Y4  
2,40 120

## MNG – Afdichtstop met O-ring

▲ MNG – Mechanisch nulpuntspansysteem

MNG



G
M12

80 899 ...

EUR  
Y4  
2,40 126

## MNG – positioneerpen-set

▲ MNG – Mechanisch nulpuntspansysteem

▲ voor ESG mini en direct spannen van werkstukken

▲ prijs per 2 stuks

MNG

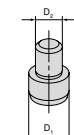

voor breedte	D <sub>1</sub>	D <sub>2</sub>
mm	mm	mm
65	12	8

80 899 ...

EUR  
Y4  
34,70 128

## MNG – indexeerpen

▲ MNG – Mechanisch nulpuntspansysteem

MNG

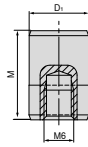

D <sub>1</sub> mm	M mm
12	18

80 899 ...  
EUR  
Y4  
17,30 51500

## MNG –

### Opspanbouten set voor T-gleuf

▲ MNG – Mechanisch nulpuntspansysteem

leveromvang:

Opspanbouten en T-moeren

MNG



voor gleuf-breedte mm	G	EUR Y4	80 899 ...
12	M8	31,10	63800
12	M10	11,50	63400
14	M8	31,10	63900
14	M12	13,80	63500 <sup>1)</sup>
16	M8	31,10	64000
16	M12	13,80	63600 <sup>1)</sup>
18	M8	31,10	64100
18	M12	13,80	63700 <sup>1)</sup>

1) met bouten met lage kop

## MNG –

### Opspan-set voor 14 mm T-gleuf

▲ MNG – Mechanisch nulpuntspansysteem

▲ de T-moeren zijn gemodificeerd voor 63 mm sleuf-afstand

▲ prijs per 2 stuks

MNG



voor gleuf-breedte mm	A mm
14	63

80 899 ...  
EUR  
Y4  
96,10 614

## MNG –

### Uitricht/centreerset voor T-gleuven

▲ MNG – Mechanisch nulpuntspansysteem

▲ A = sleuf afstand

leveromvang:

1 klemlijst, 2 T-moeren, 2 bouten, 2 ringen voor breedte 12 mm, zonder klemlijst!

MNG



A mm	voor gleuf-breedte mm	EUR Y4	80 899 ...
50	12	71,30	012 <sup>1)</sup>
50	14	71,30	014
50	16	71,30	016
50	18	71,30	018
100	12	93,90	81200
100	14	93,90	81400
100	16	93,90	81600
100	18	93,90	81800

1) voor breedte 12 mm, zonder klemlijst

## MNG – Ronde klemvingers

▲ MNG – Mechanisch nulpuntspansysteem

▲ set a 2 stuks

▲ prijs voor 2 stuks

MNG



80 899 ...  
EUR  
Y4  
81,00 300

## MNG – Spaneenheid

▲ MNG – Mechanisch nulpuntspansysteem

▲ set 3-delig

▲ voor MNG rond

MNG



80 899 ...  
EUR  
Y4  
126,00 026

MNG



## MNG-opspanmogelijkheden

## MNG – Rechthoekige grondplaat

## Bevestiging:

- 2 x M12 bouten met lage kop
- 1 x Uitricht- en centreerset

→ pagina 148  
Hier vindt u geschikte bouten.

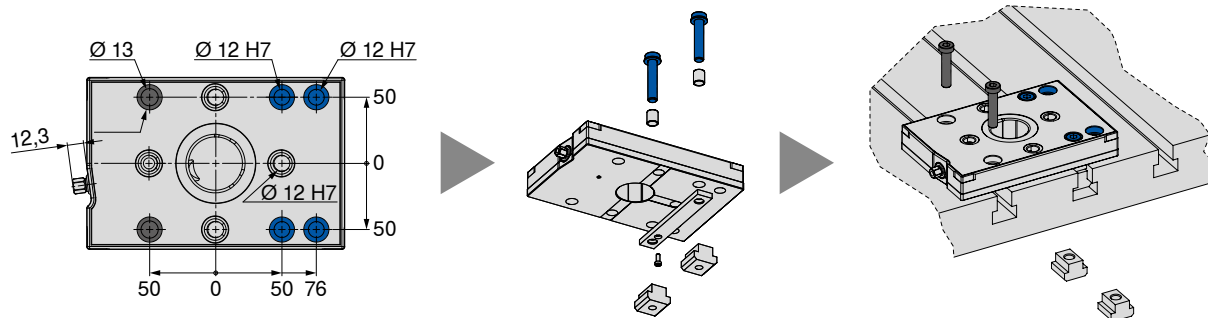

## MNG – Rechthoekige 2 voudige grondplaat

## Bevestiging:

- 4 x M12 bouten met lage kop
- 1 x Uitricht- en centreerset
- 4 x M8 speciale MNG bouten

→ pagina 148  
Hier vindt u geschikte bouten.

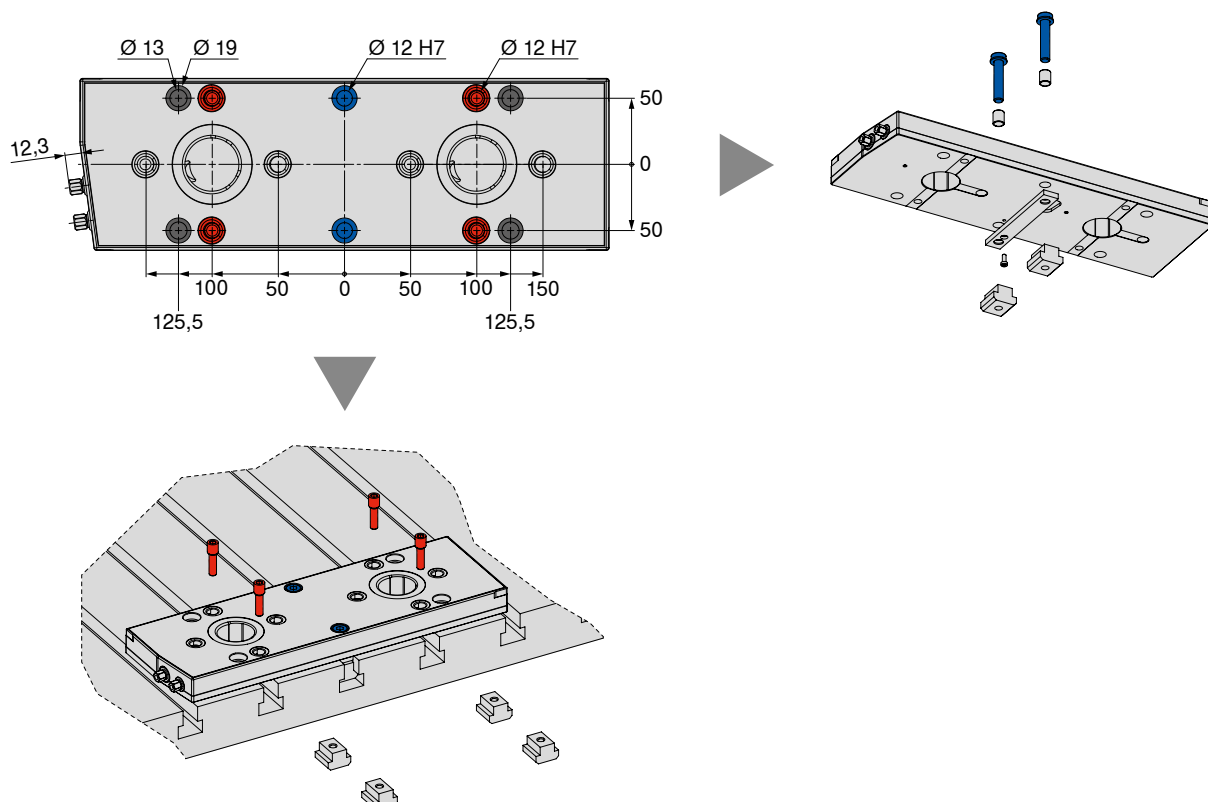

## MNG-opspanmogelijkheden

## MNG – Rechthoekige 3 voudige grondplaat

## Bevestiging:

- 5 x M12 bouten met lage kop
- 1 x Uitricht- en centreerset
- 5 x M8 speciale MNG bouten



→ pagina 148

Hier vindt u geschikte bouten.

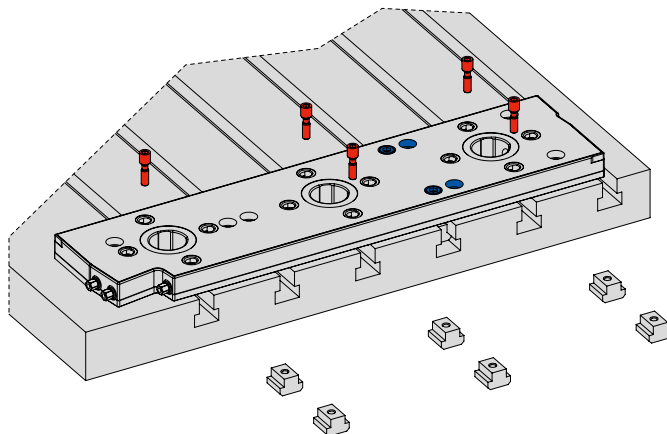
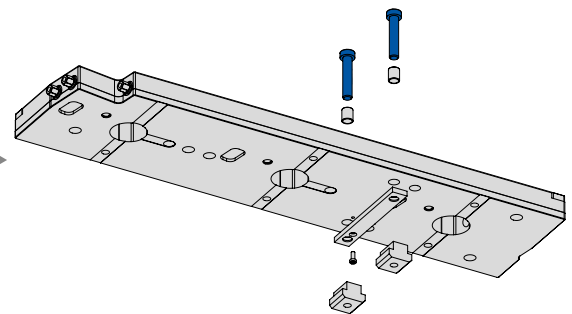
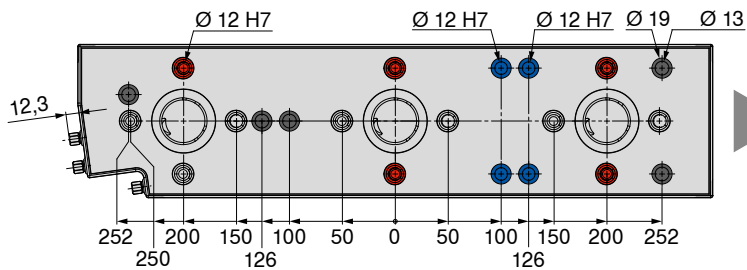

# MNG-opspanmogelijkheden

T-gleuf tafel – afstand 126 mm / 63 mm													
	12 mm			14 mm			16 mm			18 mm			
	●	●	●	●	●	●	●	●	●	●	●	●	
	Uitricht- en centreerset afstand 100 mm 80 899 81200	Opspanset met M10-bouten met lage kop 80 899 63400	Opspanset met M8 speciale MNG bouten 80 899 63800	Uitricht- en centreerset afstand 100 mm 80 899 81400	Opspanset met M12-bouten met lage kop 80 899 63500	Opspanset met M8 speciale MNG bouten 80 899 63900	Uitricht- en centreerset afstand 100 mm 80 899 81600	Opspanset met M12-bouten met lage kop 80 899 63600	Opspanset met M8 speciale MNG bouten 80 899 64000	Uitricht- en centreerset afstand 100 mm 80 899 81800	Opspanset met M12-bouten met lage kop 80 899 63700	Opspanset met M8 speciale MNG bouten 80 899 64100	
	MNG – Rechthoekige grondplaat	1 x	2 x	—	1 x	2 x	—	1 x	2 x	—	1 x	2 x	—
	MNG – Rechthoekige 2 voudige grondplaat	1 x	4 x	—	1 x	4 x	—	1 x	4 x	—	1 x	4 x	—
MNG – Rechthoekige 3 voudige grondplaat	1 x	4 x	2 x	1 x	4 x	2 x	1 x	4 x	2 x	1 x	4 x	2 x	

T-gleuf tafel – afstand 100 mm / 50 mm													
	12 mm			14 mm			16 mm			18 mm			
	●	●	●	●	●	●	●	●	●	●	●	●	
	Uitricht- en centreerset afstand 100 mm 80 899 81200	Opspanset met M10-bouten met lage kop 80 899 63400	Opspanset met M8 speciale MNG bouten 80 899 63800	Uitricht- en centreerset afstand 100 mm 80 899 81400	Opspanset met M12-bouten met lage kop 80 899 63500	Opspanset met M8 speciale MNG bouten 80 899 63900	Uitricht- en centreerset afstand 100 mm 80 899 81600	Opspanset met M12-bouten met lage kop 80 899 63600	Opspanset met M8 speciale MNG bouten 80 899 64000	Uitricht- en centreerset afstand 100 mm 80 899 81800	Opspanset met M12-bouten met lage kop 80 899 63700	Opspanset met M8 speciale MNG bouten 80 899 64100	
	MNG – Rechthoekige grondplaat	1 x	2 x	—	1 x	2 x	—	1 x	2 x	—	1 x	2 x	—
	MNG – Rechthoekige 2 voudige grondplaat	1 x	—	4 x	1 x	—	4 x	1 x	—	4 x	1 x	—	4 x
MNG – Rechthoekige 3 voudige grondplaat	1 x	1 x	5 x	1 x	1 x	5 x	1 x	1 x	5 x	1 x	1 x	5 x	

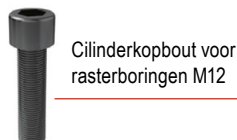
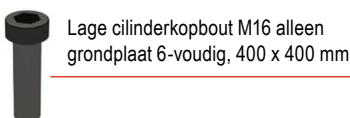

→ pagina 145  
→ pagina 182+183  
Hier vindt u de hierboven afgebeelde artikelen.

## MNG mini – Console

- ▲ met ingebouwd MNG mini nulpuntspansysteem
- ▲ Opnamebouten apart bestellen
- ▲ Materiaal: Hardgeanodiseerd aluminium

**MNG  
mini**

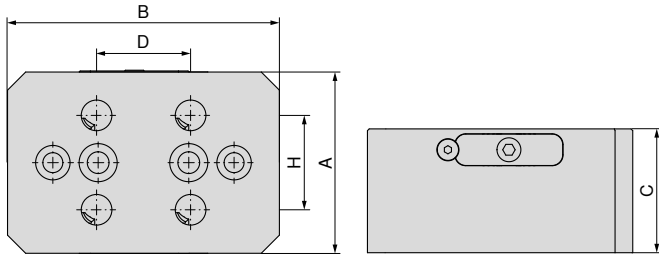

**NEW**

**80 915 ...**

EUR  
Y4

770,00 57000

A	B	C	D	H
mm	mm	mm	mm	mm
100	150	70	52	52

## MNG mini – 3-voudige piramide

- ▲ Incl. 3 x MNG mini nulpuntspansysteem
- ▲ Opnamebouten apart bestellen
- ▲ Materiaal: Hardgeanodiseerd aluminium

**MNG  
mini**

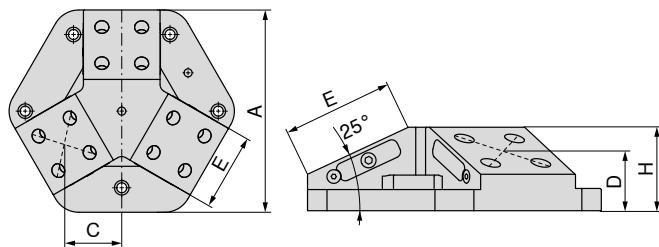

**NEW**

**80 915 ...**

EUR  
Y4

1.980,00 58000

A	C	D	E	H
mm	mm	mm	mm	mm
264	86,68	53,87	100	75

 Passend voor: ESG 5 – 80 L-130 / ZSG 4 – 80 L-130 / ZSG mini – 70 L-80 / ZSG mini – 70 L-100

## Maten van de onderzijde van MNG-mini

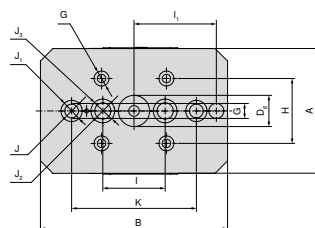

Console

A	B	D <sub>6</sub> H7	G H7	H	I	I <sub>1</sub> ±0,015	J	J <sub>1</sub>	J <sub>2</sub>	J <sub>3</sub>	K ±0,015
mm	mm	mm	mm	mm	mm	mm	mm	mm	mm	mm	mm
100	150	25	12	52	50	66	11	17	13	19	100

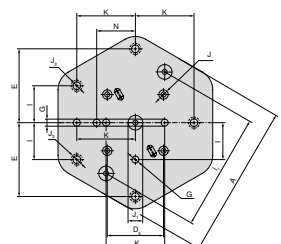

3-voudige piramide

A	D <sub>6</sub> ±0,015	E	G H7	I	I <sub>1</sub> ±0,015	J H7	J <sub>1</sub> H7	J <sub>2</sub>	J <sub>3</sub>	K	N ±0,015
mm	mm	mm	mm	mm	mm	mm	mm	mm	mm	mm	mm
264	96	126	12	63	200	16	25	13	19	100	66

## MNG mini – 4-voudige piramide

- ▲ Incl. 4 x MNG mini nulpuntspansysteem
- ▲ Opnamebouten apart bestellen
- ▲ Materiaal: Hardgeanodiseerd aluminium

MNG mini

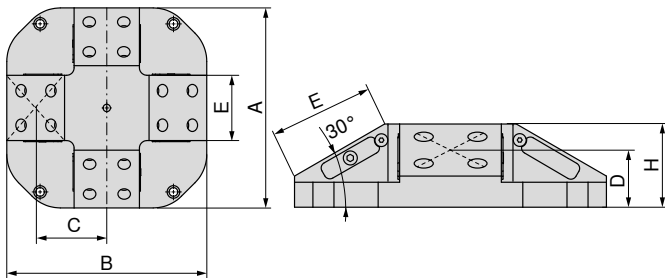

NEW

80 915 ...

EUR  
Y4

2.390,00 57500

A	B	C	D	E	H
mm	mm	mm	mm	mm	mm
300	300	106,7	55	100	80

## MNG mini – Driehoekige toren

- ▲ Incl. 3 x MNG mini nulpuntspansysteem
- ▲ Opnamebouten apart bestellen
- ▲ Materiaal: Hardgeanodiseerd aluminium

MNG mini

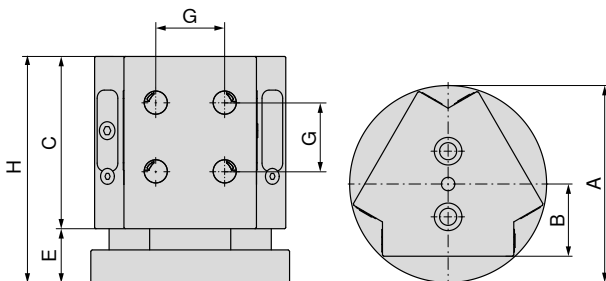

NEW

80 915 ...

EUR  
Y4

1.490,00 51700

A	B	C	E	G	H
mm	mm	mm	mm	mm	mm
148	55	130	41	52	171

 Passend voor: ESG 5 – 80 L-130 / ZSG 4 – 80 L-130 / ZSG mini – 70 L-80 / ZSG mini – 70 L-100

## Maten van de onderzijde van MNG-mini

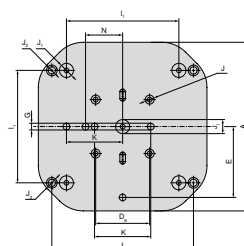

### 4-voudige piramide

A	D <sub>6</sub> ±0.015	E	G <sub>H7</sub>	I	I <sub>1</sub> ±0.015	J <sub>H7</sub>	J <sub>1H7</sub>	J <sub>2</sub>	J <sub>3</sub>	K ±0.015	N ±0.015
mm	mm	mm	mm	mm	mm	mm	mm	mm	mm	mm	mm
300	96	126	12	252	200	16	25	13	19	100	66

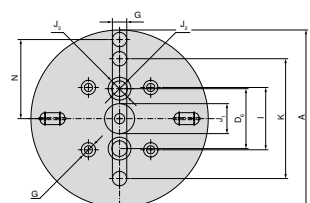

### Driehoekige toren

A	D <sub>6</sub>	G <sub>H7</sub>	I ±0.015	J <sub>1H7</sub>	J <sub>2</sub>	J <sub>3</sub>	K ±0.015	N ±0.015
mm	mm	mm	mm	mm	mm	mm	mm	mm
148	50	12	52	25	13	19	100	66

## Set opnamebouten MNG mini

leveromvang:

Set bevat vier opnamebouten

MNG  
mini

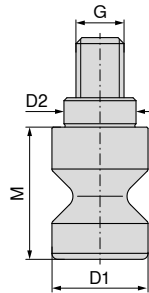

NEW

80 915 ...

EUR  
Y4

67,00 51600

D <sub>1 h6</sub> mm	D <sub>2 h6</sub> mm	M mm	G mm	TQX Nm	Spankracht kN
16	12	22	M8	18	15

## Opspanbouten set voor T-gleuf voor MNG mini

leveromvang:

Opspanbouten en T-moeren

MNG  
mini



NEW

80 915 ...

EUR  
Y4

voor gleuf-breedte mm	G	EUR Y4
12	M10	16,70 61200
14	M12	16,70 61400
16	M12	17,90 61600
18	M12	19,00 61800

## Uitricht/centreerset voor T-gleuven

▲ MNG – Mechanisch nulpuntsysteem

▲ A = sleuf afstand

leveromvang:

1 klemlijst, 2 T-moeren, 2 bouten, 2 ringen voor breedte 12 mm, zonder klemlijst!

MNG  
mini



NEW

80 915 ...

EUR  
Y4

A mm	voor gleuf-breedte mm	EUR Y4
100	12	90,70 81200
100	14	90,70 81400
100	16	90,70 81600
100	18	90,70 81800

## PNG – Spanstation 1-voudig

- ▲ PNG – Pneumatisch nulpuntspansysteem
- ▲ aantrekkraft 8 kN
- ▲ aantrekkraft met turbo 28 kN
- ▲ werkdruk 6 bar
- ▲ luchtaansluiting G 1/8

### leveromvang:

spanstation, bevestigingen, afdichtnippel, pneumatische koppelingen, afdekking, handleiding; zonder opnamepen, zonder indexeerven

PNG

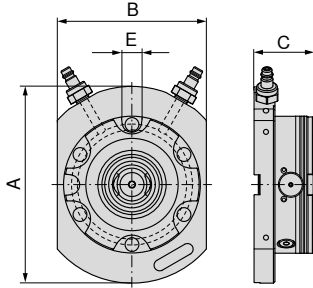

A	B	C	E <sub>H7</sub>	WT
mm	mm	mm	mm	kg
198	150	60	20	7

80 809 ...

EUR  
Y4

1.500,00 01100

## PNG – Spanstation 2-voudig, 399 x 199 mm

- ▲ PNG – Pneumatisch nulpuntspansysteem
- ▲ aantrekkraft 16 kN
- ▲ werkdruk 6 bar
- ▲ luchtaansluiting G 1/8

### leveromvang:

spanstation, bevestigingen, afdichtnippel, pneumatische koppelingen, afdekking, handleiding; zonder opnamepen, zonder indexeerven

PNG

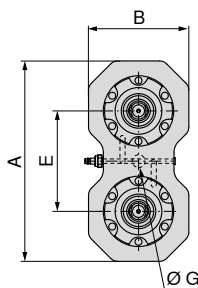

A	B	C	E	G <sub>H7</sub>	WT
mm	mm	mm	mm	mm	kg
399	199	60	200	25	16,9

80 809 ...

EUR  
Y4

2.400,00 02100

## PNG – Spanstation 4-voudig, 399 x 399 mm

- ▲ PNG – Pneumatisch nulpuntspanstelsysteem
- ▲ aantrekkraft 32 kN
- ▲ werkdruk 6 bar
- ▲ luchtaansluiting G 1/8

**leveromvang:**

spanstation, bevestigingen, afdichtnippel, pneumatische koppelingen, afdekking, handleiding; zonder opnamepen, zonder indexeerven

PNG

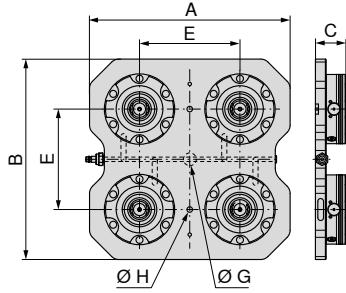

A	B	C	E	G <sub>H7</sub>	H	WT
mm	mm	mm	mm	mm	mm	kg
399	399	60	200	25	11	35,7

80 809 ...  
EUR  
Y4  
4.630,00 04100

## PNG – Spanstation 6-voudig, 599 x 399 mm

- ▲ PNG – Pneumatisch nulpuntspanstelsysteem
- ▲ aantrekkraft 48 kN
- ▲ werkdruk 6 bar
- ▲ luchtaansluiting G 1/8

**leveromvang:**

spanstation, bevestigingen, afdichtnippel, pneumatische koppelingen, afdekking, handleiding; zonder opnamepen, zonder indexeerven

PNG

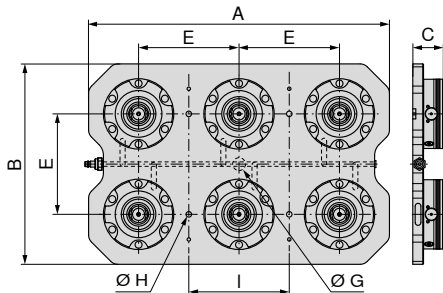

A	B	C	E	G <sub>H7</sub>	H	I	WT
mm	mm	mm	mm	mm	mm	mm	kg
599	399	60	200	25	11	200	54,4

80 809 ...  
EUR  
Y4  
6.240,00 06100



## PNG – Nulpuntspanmodule PNG.SM.138

- ▲ PNG – Pneumatisch nulpuntspanstelsysteem
- ▲ aantrekkraft 8 kN
- ▲ aantrekkraft met turbo 28 kN
- ▲ werkdruk 6 bar
- ▲ luchtaansluiting G 1/8
- ▲ repetiteernauwkeurigheid 0,005

### leveromvang:

spanmodule, bevestigingsbouten, O-ring, afdekking, handleiding; zonder opnamepen

PNG

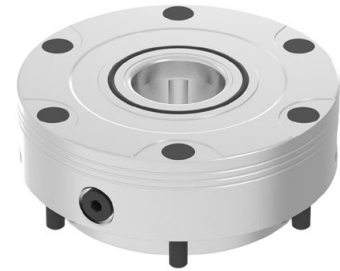
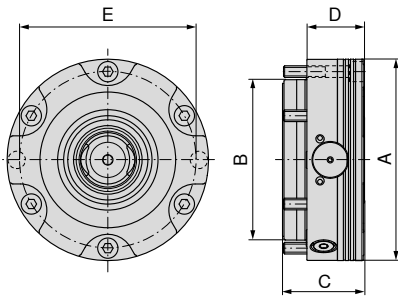

A	B	C	D	E	G	WT
mm	mm	mm	mm	mm		kg
138	110	55,7	39	121	G1/8"	4,4

80 809 ...

EUR

Y4

954,00 10100

## PNG – Nulpuntspanmodule PNG.SM.T.138

- ▲ PNG – Pneumatisch nulpuntspanstelsysteem
- ▲ aantrekkraft 7 kN
- ▲ aantrekkraft met turbo 24 kN
- ▲ werkdruk 6 bar
- ▲ luchtaansluiting G 1/8
- ▲ repetiteernauwkeurigheid 0,005

### leveromvang:

spanmodule, bevestigingsbouten, O-ring, afdekking, handleiding; zonder opnamepen

PNG

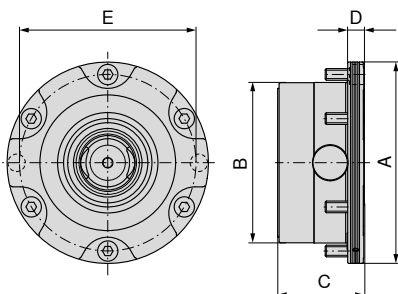

A	B	C	D	E	G	WT
mm	mm	mm	mm	mm		kg
138	110	59	11	121	G1/8"	3,5

80 809 ...

EUR

Y4

1.040,00 12100

## PNG – Nulpuntspanmodule PNG.SM.V.138

- ▲ PNG – Pneumatisch nulpuntspanstelsysteem
- ▲ aantrekkraft 8 kN
- ▲ aantrekkraft met turbo 28 kN
- ▲ werkdruk 6 bar
- ▲ luchtaansluiting G 1/8
- ▲ repetiteernauwkeurigheid 0,005

**leveromvang:**

spanmodule, bevestigingsbouten, pasbout, O-ring, afdekking, handleiding; zonder opnamepen, zonder indexeerven

PNG

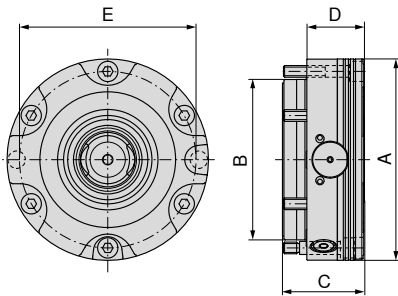

A	B	C	D	E	G	WT
mm	mm	mm	mm	mm		kg
138	110	55,7	39	121	G1/8"	4,4

80 809 ...  
EUR  
Y4  
1.020,00 11100

## PNG – Aluminium vormspantang

- ▲ PNG – Pneumatisch nulpuntspanstelsysteem
- ▲ max. spankracht 50 kN
- ▲ repetiteernauwkeurigheid 0,005
- ▲ spanweg 0,5 mm
- ▲ materiaal aluminium

**leveromvang:**

aluminium vormspantang, instelring, opnamepen, indexeerven, handleiding

PNG

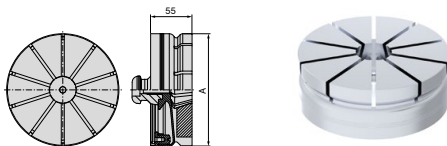

A	WT
mm	kg
149	1,5

80 809 ...  
EUR  
Y4  
324,00 07600

## PNG – indexeerven

- ▲ PNG – Pneumatisch nulpuntspanstelsysteem

PNG

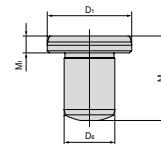

D <sub>1</sub> h5	M	M <sub>1</sub>	D <sub>3</sub> m6
mm	mm	mm	mm
20	20	4	12

80 809 ...  
EUR  
Y4  
52,30 073

## Montage – PNG opnamepen

De te monteren opspanningen of spanners worden met drie soorten opnamepenen gepositioneerd en vastgezet:



**Centreerpen**  
Precisiegeslepen, bedoeld voor de positionering van de opspanning.



**Positioneerpen**  
Deze opnamepenen worden slechts in één axiale richting geslepen zodat het systeem niet overbelast raakt.



**Spanpen**  
Deze opname met een iets korter geslepen conus, is bedoeld om de pallet of spanner vlak op het systeem trekken.

## PNG – opnamepen

- ▲ PNG – Pneumatisch nulpuntspanstelsysteem
- ▲ 3 type penen – ZB (centreerpen), PB (positioneerpen), HB (spanpen)
- ▲ hoognauwkeurige aanpassing van de maten aan de functie
- ▲ klemkracht 50 kN

**leveromvang:**  
incl. bevestigingsbout M10

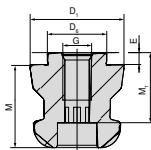

80 809 ...

Type	D <sub>6</sub> h6 mm	D <sub>1</sub> h6 mm	M mm	M <sub>1</sub> mm	E mm	G	EUR Y4	
ZB	25	40	35	27	5	M12	57,40	070
PB	25	40	35	27	5	M12	69,10	071
HB	25	40	35	27	5	M12	52,10	072

## PNG – Conusafsluiting

- ▲ PNG – Pneumatisch nulpuntspanstelsysteem
- ▲ afdekking ter bescherming van de aansluiting

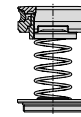

80 809 ...

WT  
kg  
0,11

EUR  
Y4  
121,00 07500

## PNG – afdekking

- ▲ PNG – Pneumatisch nulpuntspanstelsysteem
- ▲ afdekking ter bescherming van de aansluiting

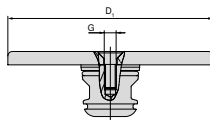

80 809 ...

D <sub>1</sub> mm	G	EUR Y4	
138	M8	94,90	074

## Overzicht multi-adapterpallets



Multi-adapterpallet, 159 x 159 mm

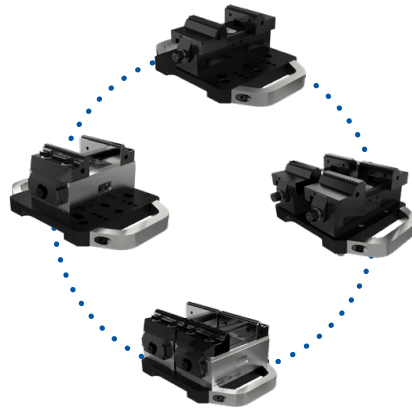

Toepassingsvoorbeelden

## Multi-adapterpallet, 159 x 159 mm

▲ Multi-adapterpallet voor bevestiging op PNG en MNG

### leveromvang:

incl. drukstuk en spanbout  
zonder opnamepen

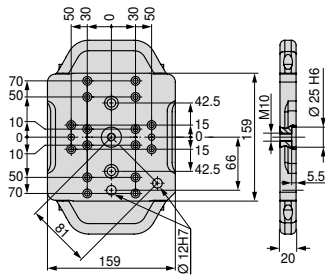

grootte	WT	80 809 ...
159x159 mm	4 kg	EUR Y4 502,00 500

## Montageset – multi-adapterpallet, 159 x 159 mm

▲ prijs per set



voor	80 878 ...
ZSG-4.80	EUR Y4 17,30 503

## Overzicht multi-adapterpallets



Multi-adapterpallet, 399 x 159 mm

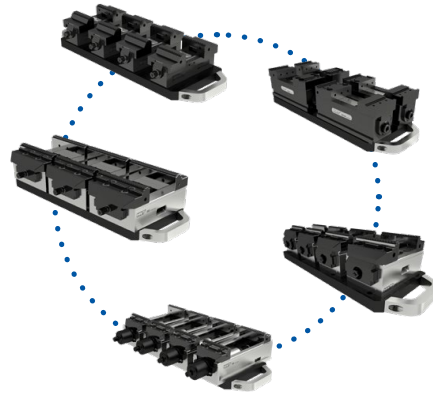

Toepassingsvoorbeelden

## Multi-adapterpallet, 399 x 159 mm

▲ Multi-adapterpallet voor bevestiging op PNG en MNG

### leveromvang:

incl. drukstuk en spanbout  
zonder opnamepen

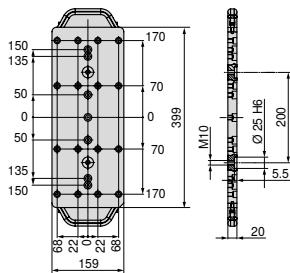

grootte	WT
399x159 mm	10 kg

<b>80 809 ...</b>
EUR
Y4
737,00 501

## Montageset – multi-adapterpallet, 399 x 159 mm

▲ prijs per set



voor
ZSG-3.65/ZSG-4.80/125L160/ESG-4.80

<b>80 884 ...</b>
EUR
Y4
39,00 503

## Overzicht multi-adapterpallets



Multi-adapterpallet, 399 x 399 mm

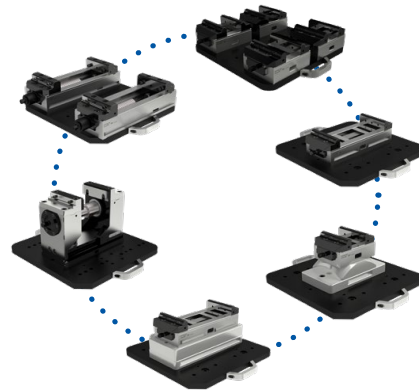

Toepassingsvoorbeelden

## Multi-adapterpallet, 399 x 399 mm

▲ multi-adapterpallet voor bevestiging op PNG en MNG

### leveromvang:

incl. drukstuk en spanbout  
zonder opnamepen

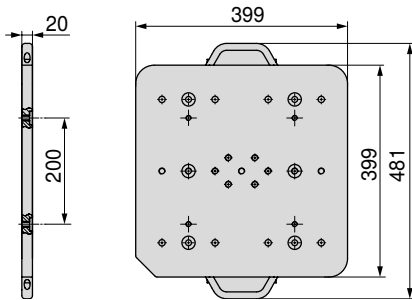

grootte	WT
399x399 mm	25 kg

80 809 ...
EUR Y4
1.380,00 502

## Montageset – multi-adapterpallet, 399 x 399 mm

▲ prijs per set



voor	80 901 ...	80 898 ...	80 878 ...
	EUR Y4	EUR Y4	EUR Y4
ESG4.125	55,10 500		
H5G.125		55,10 500	
ZSG-4.125.L160			17,30 500
ZSG-4.125.L160.K			55,10 502
ZSG-4.125.L300			55,10 501
ZSG-4.125.L300-DK			55,10 504

## Spanpallet staal, 159 x 159 mm

- ▲ spanpallet voor bevestiging op PNG
- ▲ zonder boorpatroon

### leveromvang:

onbewerkte spanpallet PNG-opnamepennen en positioneerstift

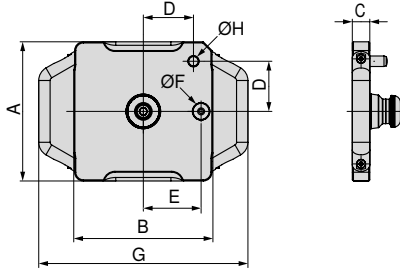

grootte	A	B	C	D	E	F <sub>H5</sub>	G	H <sub>M6</sub>	WT
	mm	mm	mm	mm	mm	mm	mm	mm	kg
159x159 mm	159	159	20	58	66	20	239	12	4,2

80 809 ...

EUR  
Y4

333,00 080

## Spanpallet aluminium, 159 x 159 mm

- ▲ spanpallet voor bevestiging op PNG
- ▲ zonder boorpatroon

### leveromvang:

onbewerkte spanpallet PNG-opnamepennen en positioneerstift

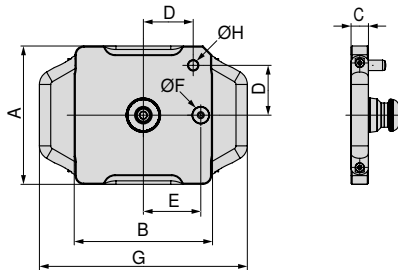

grootte	A	B	C	D	E	F <sub>H5</sub>	G	H <sub>M6</sub>	WT
	mm	mm	mm	mm	mm	mm	mm	mm	kg
159x159 mm	159	159	25	58	66	20	239	12	2,2

80 809 ...

EUR  
Y4

376,00 081

## Spanpallet staal, 399 x 159 mm

- ▲ spanpallet voor bevestiging op PNG en MNG
- ▲ zonder boorpatroon

**leveromvang:**

onbewerkte spanpallet PNG-opnamepennen en positioneerstift

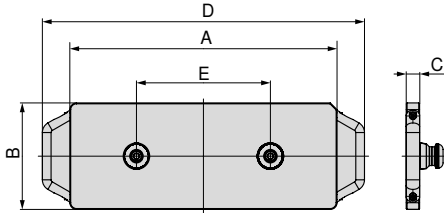

grootte	A mm	B mm	C mm	D mm	E mm	WT kg
399x159 mm	399	159	20	481	200	10,6

80 809 ...  
EUR  
Y4  
668,00 082

## Spanpallet aluminium, 399 x 159 mm

- ▲ spanpallet voor bevestiging op PNG en MNG
- ▲ zonder boorpatroon

**leveromvang:**

onbewerkte spanpallet PNG-opnamepennen en positioneerstift

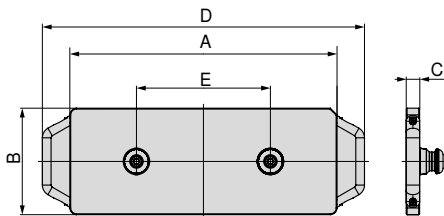

grootte	A mm	B mm	C mm	D mm	E mm	WT kg
399x159 mm	399	159	25	481	200	5,1

80 809 ...  
EUR  
Y4  
584,00 083



## Spanpallet staal, 399 x 399 mm

- ▲ spanpallet voor bevestiging op PNG en MNG
- ▲ zonder boorpatroon

### leveromvang:

onbewerkte spanpallet PNG-opnamepennen en positioneerstift

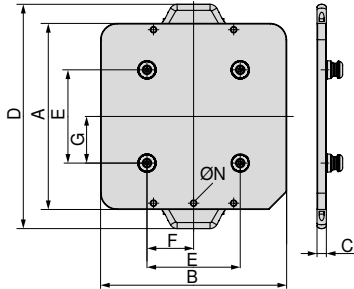

grootte	A	B	C	D	E	F	G	N	WT
	mm	mm	mm	mm	mm	mm	mm	M10	kg
399x399 mm	399	399	20	481	200	100	100	M10	28

80 809 ...

EUR  
Y4

1.460,00 084

## Spanpallet aluminium, 399 x 399 mm

- ▲ spanpallet voor bevestiging op PNG en MNG
- ▲ zonder boorpatroon

### leveromvang:

onbewerkte spanpallet PNG-opnamepennen en positioneerstift

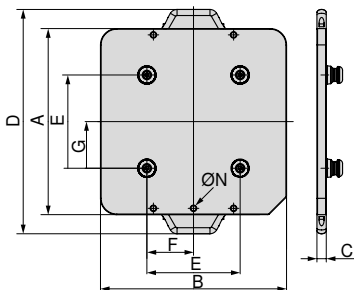

grootte	A	B	C	D	E	F	G	N	WT
	mm	mm	mm	mm	mm	mm	mm	M10	kg
399x399 mm	399	399	25	481	200	100	100	M10	12

80 809 ...

EUR  
Y4

1.070,00 085

## Spanpallet staal, 599 x 159 mm

- ▲ spanpallet voor bevestiging op PNG en MNG
- ▲ zonder boorpatroon

**leveromvang:**

onbewerkte spanpallet PNG-opnamepennen en positioneerstift

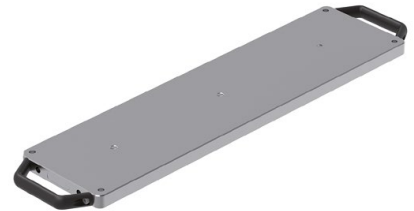
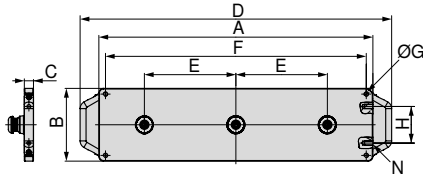

grootte	A	B	C	D	E	F	G	H	N	WT
	mm	mm	mm	mm	mm	mm		mm		kg
599x159 mm	599	159	20	681	200	570	M10	80	M10	15,6

<b>80 809 ...</b>
EUR
Y4
936,00 086

## Spanpallet aluminium, 599 x 159 mm

- ▲ spanpallet voor bevestiging op PNG en MNG
- ▲ zonder boorpatroon

**leveromvang:**

onbewerkte spanpallet PNG-opnamepennen en positioneerstift

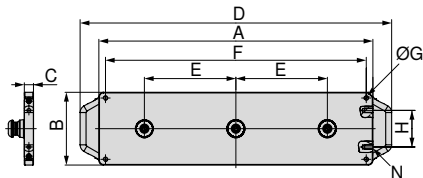

grootte	A	B	C	D	E	F	G	H	N	WT
	mm	mm	mm	mm	mm	mm		mm		kg
599x159 mm	599	159	25	681	200	570	M10	80	M10	7,4

<b>80 809 ...</b>
EUR
Y4
1.020,00 087

# Overzicht algemene bekken

## 6-voudige bek

- ▲ 1 = glad, wolframcarbide gecoat
- ▲ 2 = grip met trap 3 mm
- ▲ 3 = grip met trap 8 mm
- ▲ 4 = grip met trap 18 mm
- ▲ 5 = grip met trap 8 mm
- ▲ 6 = grip rond
- ▲  $M_{max} = 60 \text{ Nm}$
- ▲ incl. bevestigingsbout

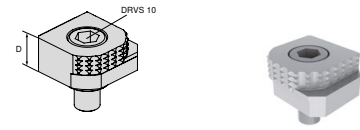

voor basisbreedte	A	A <sub>1</sub>	D	D <sub>1</sub>	D <sub>2</sub>	E	M	M <sub>1</sub>	M <sub>2</sub>	EUR	Y4	NCG	H5G / -S / -Z	X5G-Z / -S	ESG 4	ESG 5	HDG 2	ZSG 4	ZSG mini	DSG 4	Verso	HSG	
			18							80,60	80 892 246	●	●	●	●				●	●	●	●	

## 6-voudige bek

- ▲ 1 = glad
- ▲ 2 = carbide grip
- ▲ 3 = carbide grip met trap 3 mm
- ▲ 4 = carbide grip met trap 8 mm
- ▲ 5 = carbide grip rond met trap 8 mm
- ▲ 6 = carbide grip rond
- ▲ incl. bevestigingsbout

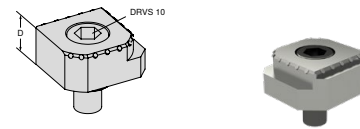

voor basisbreedte	A	A <sub>1</sub>	D	D <sub>1</sub>	D <sub>2</sub>	E	M	M <sub>1</sub>	M <sub>2</sub>	EUR	Y4	NCG	H5G / -S / -Z	X5G-Z / -S	ESG 4	ESG 5	HDG 2	ZSG 4	ZSG mini	DSG 4	Verso	HSG	
			18							117,00	80 890 35300	●	●	●	●				●	●	●	●	

## Positioneerplaat

- ▲ voor getrapte bekken met T-gleuf
- ▲ verschillende inspandieptes door infrezen te bereiken
- ▲ door infrezen van een nok als aanslag in te zetten
- ▲ materiaal 1.7131 daardoor indien gewenst nadien hardbaar
- ▲ prijs per stuk

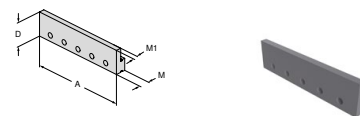

voor basisbreedte	A	A <sub>1</sub>	D	D <sub>1</sub>	D <sub>2</sub>	E	M	M <sub>1</sub>	M <sub>2</sub>	EUR	Y4	NCG	H5G / -S / -Z	X5G-Z / -S	ESG 4	ESG 5	HDG 2	ZSG 4	ZSG mini	DSG 4	Verso	HSG
	100		32				13,5	7		48,90	80 892 338	●						●				●
	125		32				13,5	7		51,30	80 892 339	●	●					●	●		●	●
	160		32				13,5	7		49,70	80 892 340	●						●				●

# Overzicht algemene bekken

## Getrapte bek, grip met T-gleuf

- ▲ T-moer voor opname van positioneerplaat
- ▲ door 6,5 mm breed oplegvlak uitstekend geschikt voor werkstukken met grove kanten
- ▲ ingelaserde verdeling (2 mm) als positioneerhulp
- ▲ prijs per stuk

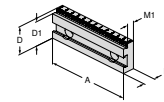

voor basisbreedte	A	A <sub>1</sub>	D	D <sub>1</sub>	D <sub>2</sub>	E	M	M <sub>1</sub>	M <sub>2</sub>	EUR	Y4	NCG	H5G / -S / -Z	X5G-Z / -S	ESG 4	ESG 5	HDG 2	ZSG 4	ZSG mini	DSG 4	Verso	HSG	
100			35	32			17,5	11,5		131,00	80 892 341	●					●						●
100			35	30			17,5	11,5		131,00	80 892 342	●					●						●
100			35	27			17,5	11,5		131,00	80 892 343	●					●						●
125			40	37			17,5	11,5		142,00	80 892 344	●	●		●		●	●			●		●
125			40	35			17,5	11,5		141,00	80 892 345	●	●		●		●	●			●		●
125			40	32			17,5	11,5		141,00	80 892 346	●	●		●		●	●			●		●
160			50	45			20	13,5		158,00	80 892 348	●			●		●	●			●		●
160			50	42			20	13,5		158,00	80 892 349	●			●		●	●					●

## Getrapte bekken, glad

- ▲ prijs per stuk

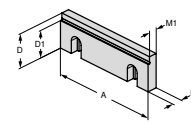

voor basisbreedte	A	A <sub>1</sub>	D	D <sub>1</sub>	D <sub>2</sub>	E	M	M <sub>1</sub>	M <sub>2</sub>	EUR	Y4	NCG	H5G / -S / -Z	X5G-Z / -S	ESG 4	ESG 5	HDG 2	ZSG 4	ZSG mini	DSG 4	Verso	HSG	
100			35	30			10	7,5		86,40	80 892 21400	●					●						●
125			40	32			11,5	9,5		103,00	80 892 21500	●	●		●		●	●			●		●
160			50	42			13,5	10,5		186,00	80 892 21600	●			●		●	●			●		●

## Getrapte bek glad

- ▲ kan als gladde of getrapte bek ingezet worden
- ▲ Bekken gehard en geslepen
- ▲ prijs per stuk

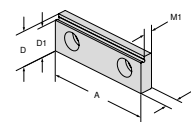

voor basisbreedte	A	A <sub>1</sub>	D	D <sub>1</sub>	D <sub>2</sub>	E	M	M <sub>1</sub>	M <sub>2</sub>	EUR	Y4	NCG	H5G / -S / -Z	X5G-Z / -S	ESG 4	ESG 5	HDG 2	ZSG 4	ZSG mini	DSG 4	Verso	HSG	
65			22	19			8	5,5		72,40	80 895 332	●											

## Getrapte bek 5 mm, gecoat

- ▲ prijs per stuk

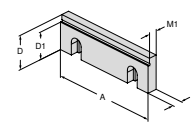

voor basisbreedte	A	A <sub>1</sub>	D	D <sub>1</sub>	D <sub>2</sub>	E	M	M <sub>1</sub>	M <sub>2</sub>	EUR	Y4	NCG	H5G / -S / -Z	X5G-Z / -S	ESG 4	ESG 5	HDG 2	ZSG 4	ZSG mini	DSG 4	Verso	HSG	
80			28	23			10	7,5		156,00	80 878 31400				●			●		●			

# Overzicht algemene bekken

## Getrapte bek 5 mm, gecoat

▲ prijs per stuk

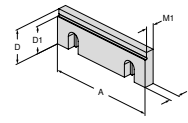

voor basisbreedte	A	A <sub>1</sub>	D	D <sub>1</sub>	D <sub>2</sub>	E	M	M <sub>1</sub>	M <sub>2</sub>	EUR	Y4	NCG	H5G / -S / -Z	X5G-Z / -S	ESG 4	ESG 5	HDG 2	ZSG 4	ZSG mini	DSG 4	Verso	HSG	
	100		35	30			10	7,5		171,00	80 892 36300	●						●					
	125		40	35			11,5	9,5		151,00	80 892 250	●	●		●			●			●		●
	160		50	45			13,5	10,5		213,00	80 892 36400	●						●					●

## Getrapte bek 5 mm

▲ prijs per stuk

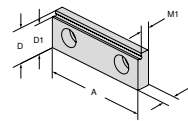

voor basisbreedte	A	A <sub>1</sub>	D	D <sub>1</sub>	D <sub>2</sub>	E	M	M <sub>1</sub>	M <sub>2</sub>	EUR	Y4	NCG	H5G / -S / -Z	X5G-Z / -S	ESG 4	ESG 5	HDG 2	ZSG 4	ZSG mini	DSG 4	Verso	HSG	
	80		28	23			10	7,5		128,00	80 878 830				●				●		●		

## Getrapte bek, grip

▲ prijs per stuk

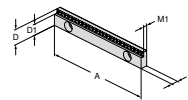

voor basisbreedte	A	A <sub>1</sub>	D	D <sub>1</sub>	D <sub>2</sub>	E	M	M <sub>1</sub>	M <sub>2</sub>	EUR	Y4	NCG	H5G / -S / -Z	X5G-Z / -S	ESG 4	ESG 5	HDG 2	ZSG 4	ZSG mini	DSG 4	Verso	HSG	
	125		18	13			8	5,5		135,00	80 898 252		●		●						●		
	125		18	15			8	5,5		135,00	80 898 250		●		●						●		

## Getrapte gripbek 3 mm

▲ prijs per stuk

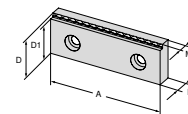

voor basisbreedte	A	A <sub>1</sub>	D	D <sub>1</sub>	D <sub>2</sub>	E	M	M <sub>1</sub>	M <sub>2</sub>	EUR	Y4	NCG	H5G / -S / -Z	X5G-Z / -S	ESG 4	ESG 5	HDG 2	ZSG 4	ZSG mini	DSG 4	Verso	HSG	
	80		28	25			10	7		91,70	80 906 30900				●				●		●		

## Overzicht algemene bekken

Getrapte gripbekken 3, 5 en 8 mm

▲ prijs per stuk

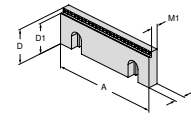

voor basisbreedte	A	A <sub>1</sub>	D	D <sub>1</sub>	D <sub>2</sub>	E	M	M <sub>1</sub>	M <sub>2</sub>	EUR	Y4	NCG	H5G / -S / -Z	X5G-Z / -S	ESG 4	ESG 5	HDG 2	ZSG 4	ZSG mini	DSG 4	Versto	HSG	
100			35	27			10	7,5		108,00	80 892 29200	●					●						●
100			35	30			10	7,5		108,00	80 892 29000	●					●						●
100			35	32			10	7,5		108,00	80 892 29400	●					●						●
125			40	32			11,5	9		124,00	80 892 29300	●	●		●		●	●			●		●
125			40	35			11,5	9		124,00	80 892 29100	●	●		●		●	●			●		●
125			40	37			11,5	9		124,00	80 892 29500	●	●		●		●	●			●		●
160			50	42			13,5	11		138,00	80 892 29900	●			●		●	●			●		●
160			50	45			13,5	11		138,00	80 892 29800	●			●		●	●			●		●
160			50	47			13,5	11		138,00	80 892 29700	●			●		●	●			●		●

## Carbide getrapte gripbek, 3 mm

▲ prijs per stuk

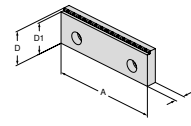

voor basisbreedte	A	A <sub>1</sub>	D	D <sub>1</sub>	D <sub>2</sub>	E	M	M <sub>1</sub>	M <sub>2</sub>	EUR	Y4	NCG	H5G / -S / -Z	X5G-Z / -S	ESG 4	ESG 5	HDG 2	ZSG 4	ZSG mini	DSG 4	Versto	HSG	
100			35	32			7,5			156,00	80 892 37600	●	●		●		●	●			●		●
125			40	37			11,5			171,00	80 892 36500	●	●		●		●	●			●		●
160			50	47			13,5			195,00	80 892 37400	●	●		●		●	●			●		●

## Getrapte carbide gripbek 5 mm

▲ prijs per stuk

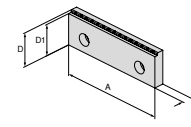

voor basisbreedte	A	A <sub>1</sub>	D	D <sub>1</sub>	D <sub>2</sub>	E	M	M <sub>1</sub>	M <sub>2</sub>	EUR	Y4	NCG	H5G / -S / -Z	X5G-Z / -S	ESG 4	ESG 5	HDG 2	ZSG 4	ZSG mini	DSG 4	Versto	HSG	
100			35	30			12			156,00	80 892 37700	●	●		●		●	●			●		●
125			40	35			13,5			171,00	80 892 37500	●	●		●		●	●			●		●
160			50	45			15,5			195,00	80 892 37300	●	●		●		●	●			●		●

## Getrapte bek 18 mm met 3 mm grip

▲ prijs per stuk

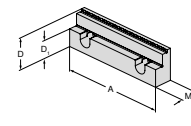

voor basisbreedte	A	A <sub>1</sub>	D	D <sub>1</sub>	D <sub>2</sub>	E	M	M <sub>1</sub>	M <sub>2</sub>	EUR	Y4	NCG	H5G / -S / -Z	X5G-Z / -S	ESG 4	ESG 5	HDG 2	ZSG 4	ZSG mini	DSG 4	Versto	HSG	
125			40	22			21,5			222,00	80 892 288	●	●		●		●	●			●		●

## Overzicht algemene bekken

Getrapte bek 18 mm met 3 mm grip

▲ prijs per stuk

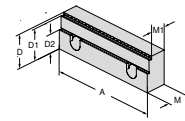

voor basisbreedte	A	A <sub>1</sub>	D	D <sub>1</sub>	D <sub>2</sub>	E	M	M <sub>1</sub>	M <sub>2</sub>
	125		40	37	22		24	19	

EUR

Y4

235,00

80 907 302

NCG	H5G / -S / -Z	X5G-Z / -S	ESG 4	ESG 5	HDG 2	ZSG 4	ZSG mini	DSG 4	Verzo	HSG
•	•		•		•	•		•		•

Getrapte gripbek, 5 mm voor aluminium en kunststof

▲ prijs per stuk

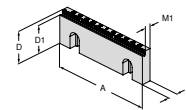

voor basisbreedte	A	A <sub>1</sub>	D	D <sub>1</sub>	D <sub>2</sub>	E	M	M <sub>1</sub>	M <sub>2</sub>
	125		40	35			11,5	8	

EUR

Y4

143,00

80 892 36100

NCG	H5G / -S / -Z	X5G-Z / -S	ESG 4	ESG 5	HDG 2	ZSG 4	ZSG mini	DSG 4	Verzo	HSG
•	•		•		•	•		•		•

Getrapte bek met Prägeprofil

▲ prijs per stuk

▲ passend op LANG Prägeprofil

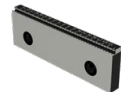
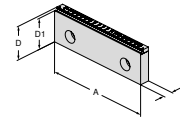

voor basisbreedte	A	A <sub>1</sub>	D	D <sub>1</sub>	D <sub>2</sub>	E	M	M <sub>1</sub>	M <sub>2</sub>
	125		40	37			11,5		

EUR

Y4

138,00

80 892 36200

NCG	H5G / -S / -Z	X5G-Z / -S	ESG 4	ESG 5	HDG 2	ZSG 4	ZSG mini	DSG 4	Verzo	HSG
•	•		•		•	•		•		•

Gripbek

▲ prijs per stuk

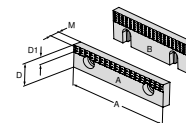

afbeelding	A	A <sub>1</sub>	D	D <sub>1</sub>	D <sub>2</sub>	E	M	M <sub>1</sub>	M <sub>2</sub>
A	40		22	7			7,8		
A	65		22	7			7,8		
A	90		22	7			7,8		
B	100		35	12			10		
B	125		40	14,5			11,5		
B	160		50	14,5			13,5		

EUR

Y4

33,50

80 892 279

37,80

80 892 280

41,00

80 892 284

51,90

80 892 21700

60,50

80 892 21800

83,20

80 892 21900

NCG	H5G / -S / -Z	X5G-Z / -S	ESG 4	ESG 5	HDG 2	ZSG 4	ZSG mini	DSG 4	Verzo	HSG
									•	
									•	
•					•					•
•			•		•			•		•
•			•		•	•				•

## Overzicht algemene bekken

### Opzetbek, grip

▲ prijs per stuk

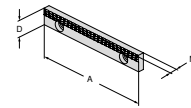

voor basisbreedte	A	A <sub>1</sub>	D	D <sub>1</sub>	D <sub>2</sub>	E	M	M <sub>1</sub>	M <sub>2</sub>	EUR	Y4	NCG	H5G / -S / -Z	X5G-Z / -S	ESG 4	ESG 5	HDG 2	ZSG 4	ZSG mini	DSG 4	Verso	HSG	
	125		18				7,8			66,90	80 898 253	●	●	●							●		

### Opzetbek geslepen

▲ prijs per stuk

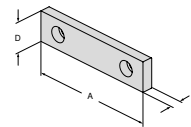

voor basisbreedte	A	A <sub>1</sub>	D	D <sub>1</sub>	D <sub>2</sub>	E	M	M <sub>1</sub>	M <sub>2</sub>	EUR	Y4	NCG	H5G / -S / -Z	X5G-Z / -S	ESG 4	ESG 5	HDG 2	ZSG 4	ZSG mini	DSG 4	Verso	HSG		
	40		22				7,7			33,50	80 889 401											●		
	40		35				10			37,80	80 889 405												●	
	65		22				7,7			37,80	80 889 651												●	
	65		35				10			41,00	80 889 655												●	
	90		22				7,7			41,00	80 889 901													●
	90		35				10			49,70	80 889 905													●

### Opzetbek geslepen

▲ prijs per stuk

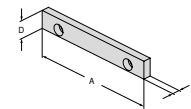

voor basisbreedte	A	A <sub>1</sub>	D	D <sub>1</sub>	D <sub>2</sub>	E	M	M <sub>1</sub>	M <sub>2</sub>	EUR	Y4	NCG	H5G / -S / -Z	X5G-Z / -S	ESG 4	ESG 5	HDG 2	ZSG 4	ZSG mini	DSG 4	Verso	HSG	
	125		18				7,6			50,80	80 898 251	●	●	●							●		

### Opzetbek WC gecoat

▲ met wolframcarbide gecoat

▲ prijs per stuk

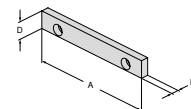

voor basisbreedte	A	A <sub>1</sub>	D	D <sub>1</sub>	D <sub>2</sub>	E	M	M <sub>1</sub>	M <sub>2</sub>	EUR	Y4	NCG	H5G / -S / -Z	X5G-Z / -S	ESG 4	ESG 5	HDG 2	ZSG 4	ZSG mini	DSG 4	Verso	HSG	
	125		18				7,6			102,00	80 898 254	●	●	●							●		



## Overzicht algemene bekken

### Bekken, glad

▲ prijs per stuk

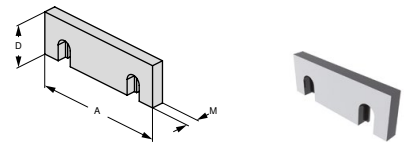

voor basisbreedte	A	A <sub>1</sub>	D	D <sub>1</sub>	D <sub>2</sub>	E	M	M <sub>1</sub>	M <sub>2</sub>	EUR	Y4	NCG	H5G / -S / -Z	X5G-Z / -S	ESG 4	ESG 5	HDC 2	ZSG 4	ZSG mini	DSG 4	Versto	HSG		
100			35				10			40,00	80 892 20400	●					●						●	
125			40				11,5			48,60	80 892 20500	●			●		●				●			●
160			50				13,5			74,70	80 892 20600	●			●		●	●						●

### Bekken, geprofileerd

▲ prijs per stuk

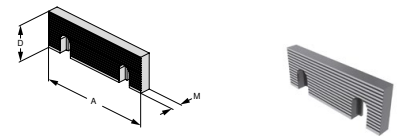

voor basisbreedte	A	A <sub>1</sub>	D	D <sub>1</sub>	D <sub>2</sub>	E	M	M <sub>1</sub>	M <sub>2</sub>	EUR	Y4	NCG	H5G / -S / -Z	X5G-Z / -S	ESG 4	ESG 5	HDC 2	ZSG 4	ZSG mini	DSG 4	Versto	HSG		
100			35				10			45,40	80 892 20700	●												●
125			40				11,5			55,10	80 892 20800	●			●		●	●			●			●
160			50				13,5			90,60	80 892 20900	●			●		●	●						●

### Gripbek, draaibaar

▲ voor verticale (3mm) en horizontale (5 mm) inzet

▲ prijs per stuk

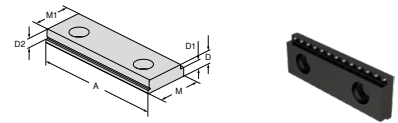

voor basisbreedte	A	A <sub>1</sub>	D	D <sub>1</sub>	D <sub>2</sub>	E	M	M <sub>1</sub>	M <sub>2</sub>	EUR	Y4	NCG	H5G / -S / -Z	X5G-Z / -S	ESG 4	ESG 5	HDC 2	ZSG 4	ZSG mini	DSG 4	Versto	HSG		
65			8	5,5	5		22	19		36,80	80 895 340	●	●											
100			10,5	8	5		35	32		51,90	80 895 343	●					●							●

### Gripbek, draaibaar

▲ voor verticale en horizontale inzet

▲ 3-punt opspanningen

▲ prijs per stuk

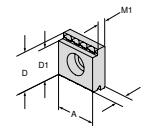

voor basisbreedte	A	A <sub>1</sub>	D	D <sub>1</sub>	D <sub>2</sub>	E	M	M <sub>1</sub>	M <sub>2</sub>	EUR	Y4	NCG	H5G / -S / -Z	X5G-Z / -S	ESG 4	ESG 5	HDC 2	ZSG 4	ZSG mini	DSG 4	Versto	HSG		
65	22		22	19			8	5,5		19,50	80 895 335	●	●					●						
100	35		35	32			10,5	8		31,40	80 895 345	●					●							

## Overzicht algemene bekken

### Bek, getand

▲ prijs per stuk

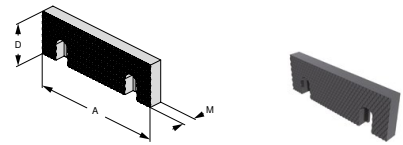

voor basisbreedte	A	A <sub>1</sub>	D	D <sub>1</sub>	D <sub>2</sub>	E	M	M <sub>1</sub>	M <sub>2</sub>	EUR	Y4	NCG	H5G / -S / -Z	X5G-Z / -S	ESG 4	ESG 5	HDG 2	ZSG 4	ZSG mini	DSG 4	Verro	HSG	
	100		35				11			54,00	80 892 20100	●					●						●
	125		40				12,5			65,90	80 892 20200	●			●		●				●		●
	160		50				14,5			76,60	80 892 20300	●			●		●	●					●

### Bek, getand

▲ prijs per stuk

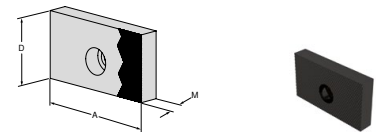

voor basisbreedte	A	A <sub>1</sub>	D	D <sub>1</sub>	D <sub>2</sub>	E	M	M <sub>1</sub>	M <sub>2</sub>	EUR	Y4	NCG	H5G / -S / -Z	X5G-Z / -S	ESG 4	ESG 5	HDG 2	ZSG 4	ZSG mini	DSG 4	Verro	HSG		
	40		35				11			37,80	80 889 408											●		
	40		22				8			33,50	80 889 404												●	
	65		35				11			41,00	80 889 658												●	
	65		22				8			37,80	80 889 654												●	
	90		35				11			49,70	80 889 908												●	
	90		22				8			41,00	80 889 904												●	

### Zachte bek (staal)

- ▲ materiaal: 16MnCr5
- ▲ alleen voor verticale inzet
- ▲ prijs per stuk

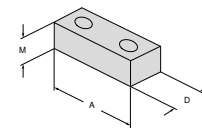

voor basisbreedte	A	A <sub>1</sub>	D	D <sub>1</sub>	D <sub>2</sub>	E	M	M <sub>1</sub>	M <sub>2</sub>	EUR	Y4	NCG	H5G / -S / -Z	X5G-Z / -S	ESG 4	ESG 5	HDG 2	ZSG 4	ZSG mini	DSG 4	Verro	HSG		
	40		22				20			33,50	80 895 244												●	
	65		22				20			37,80	80 895 245		●		●				●					●
	90		22				20			41,00	80 895 246													●

### Zachte bek (staal)

- ▲ materiaal: 14NiCr14
- ▲ voor het maken van vormbekken
- ▲ prijs per stuk

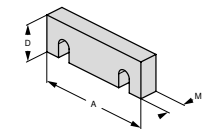

voor basisbreedte	A	A <sub>1</sub>	D	D <sub>1</sub>	D <sub>2</sub>	E	M	M <sub>1</sub>	M <sub>2</sub>	EUR	Y4	NCG	H5G / -S / -Z	X5G-Z / -S	ESG 4	ESG 5	HDG 2	ZSG 4	ZSG mini	DSG 4	Verro	HSG	
	100		35				16			43,20	80 892 24700	●						●					●
	125		40				20			50,80	80 892 24800	●	●		●		●	●			●		●
	160		50				20			83,40	80 892 24900	●			●		●	●					●

## Overzicht algemene bekken

### Prismabekken

- ▲ met horizontaal en verticaal prisma
- ▲ paralleliteit van prisma horizontaal en verticaal geslepen
- ▲ prijs per stuk

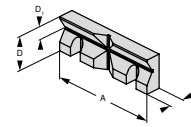

voor spandiameter	A	A <sub>1</sub>	D	D <sub>1</sub>	D <sub>2</sub>	E	M	M <sub>1</sub>	M <sub>2</sub>	EUR	Y4	NCG	H5G / -S / -Z	X5G-Z / -S	ESG 4	ESG 5	HDG 2	ZSG 4	ZSG mini	DSG 4	Verso	HSG	
11 - 41	100		35	13			15,5			128,40	80 892 26100	●					●						●
14 - 48	125		40	16			17,5			142,90	80 892 26200	●	●		●		●				●		●
16 - 60	160		50	20			19,5			214,00	80 892 26300	●			●		●	●					●

### Prismabek

- ▲ met horizontaal en verticaal prisma
- ▲ prijs per stuk

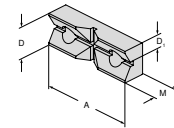

voor spandiameter	A	A <sub>1</sub>	D	D <sub>1</sub>	D <sub>2</sub>	E	M	M <sub>1</sub>	M <sub>2</sub>	EUR	Y4	NCG	H5G / -S / -Z	X5G-Z / -S	ESG 4	ESG 5	HDG 2	ZSG 4	ZSG mini	DSG 4	Verso	HSG	
11 - 22	65		22	11			15			131,00	80 895 337		●					●					

### Precisie neertrek

- ▲ neertrek is alleen geschikt voor gebruik op de losse bek
- ▲ prijs per stuk

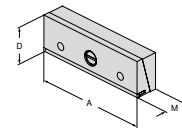

voor basisbreedte	A	A <sub>1</sub>	D	D <sub>1</sub>	D <sub>2</sub>	E	M	M <sub>1</sub>	M <sub>2</sub>	EUR	Y4	NCG	H5G / -S / -Z	X5G-Z / -S	ESG 4	ESG 5	HDG 2	ZSG 4	ZSG mini	DSG 4	Verso	HSG	
	100		35				25			259,00	80 892 370	●						●					●
	125		40				25			268,00	80 892 371	●	●		●		●				●		●
	160		50				27,5			409,00	80 892 372	●			●		●	●					●

### Neertrek tussenbek

- ▲ voor de types NCG, NCG2 en HDG2
- ▲ met aan beide zijden een neertrek veerblad
- ▲ prijs per stuk

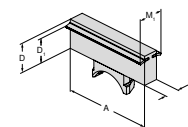

voor basisbreedte	A	A <sub>1</sub>	D	D <sub>1</sub>	D <sub>2</sub>	E	M	M <sub>1</sub>	M <sub>2</sub>	EUR	Y4	NCG	H5G / -S / -Z	X5G-Z / -S	ESG 4	ESG 5	HDG 2	ZSG 4	ZSG mini	DSG 4	Verso	HSG	
	100		35	28			28	45		289,00	80 892 258	●											
	125		40	32,5			20	35		283,00	80 892 259	●					●						
	160		50	42			20	35		337,00	80 892 260	●					●						

## Overzicht algemene bekken

### Multipin voorzetbek

▲ prijs per stuk



80 890 ...

EUR  
Y4  
315,00 30200

A mm	D mm
125	40

### Veerblad neertrekbeek

▲ voor het bewerken van een gereed product  
▲ prijs per stuk

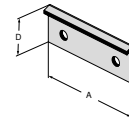

voor basisbreedte	A	A <sub>1</sub>	D	D <sub>1</sub>	D <sub>2</sub>	E	M	M <sub>1</sub>	M <sub>2</sub>	EUR	Y4	NCG	H5G / -S / -Z	X5G-Z / -S	ESG 4	ESG 5	HDG 2	ZSG 4	ZSG mini	DSG 4	Verso	HSG	
	80		24							66,90	80 901 309												
	125		35							87,40	80 901 310				•				•		•		
	160		45							99,30	80 901 311				•				•				

### Veerblad neertrekbeek

▲ voor bewerking van gereed product  
▲ prijs per stuk

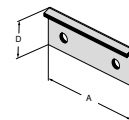

voor basisbreedte	A	A <sub>1</sub>	D	D <sub>1</sub>	D <sub>2</sub>	E	M	M <sub>1</sub>	M <sub>2</sub>	EUR	Y4	NCG	H5G / -S / -Z	X5G-Z / -S	ESG 4	ESG 5	HDG 2	ZSG 4	ZSG mini	DSG 4	Verso	HSG	
	65		23							57,30	80 898 923												
	100		36							73,40	80 898 924	•											•
	125		41							87,40	80 898 925	•											•
	160		51							99,30	80 898 926	•											•

### Veerblad neertrekbeek

▲ prijs per stuk

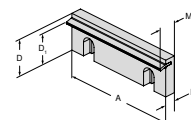

voor basisbreedte	A	A <sub>1</sub>	D	D <sub>1</sub>	D <sub>2</sub>	E	M	M <sub>1</sub>	M <sub>2</sub>	EUR	Y4	NCG	H5G / -S / -Z	X5G-Z / -S	ESG 4	ESG 5	HDG 2	ZSG 4	ZSG mini	DSG 4	Verso	HSG	
	100		35	28			10	18,5		59,50	80 892 22800	•											•
	125		40	32,5			11,5	19		69,10	80 892 22900	•			•								•
	160		50	42			13,5	21		89,60	80 892 23000	•			•								•

# Overzicht werkstuk onderlegplaten

## Werkstuk onderlegplaten, getraapt

- ▲ gehard en geslepen
- ▲ worden met behulp van veren in de basisplaat geklemd
- ▲ prijs per 2 stuks

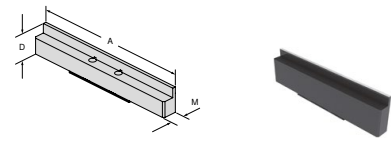

voor basisbreedte	A	A <sub>1</sub>	D	D <sub>1</sub>	D <sub>2</sub>	E	M	M <sub>1</sub>	M <sub>2</sub>	EUR	Y4	NCG	H5G / -S / -Z	X5G-Z / -S	ESG 4	ESG 5	HDG 2	ZSG 4	ZSG mini	DSG 4	Verso	HSG		
100			16				10,5			135,00	80 890 401	●												
100			11				10,5			135,00	80 890 400	●												
100			23				10,5			135,00	80 890 409	●												
100			25,5				10,5			135,00	80 890 411	●												
100			29,5				10,5			135,00	80 890 421	●												
125			32,5				10,5			157,00	80 890 395	●												
125			11				10,5			157,00	80 890 390	●												
125			16				10,5			157,00	80 890 391	●												
125			21				10,5			157,00	80 890 392	●												
125			26				10,5			157,00	80 890 393	●												
125			29				10,5			157,00	80 890 394	●												
125			36				10,5			157,00	80 890 396	●												
125			25				10,5			157,00	80 890 422	●												
160			39				10,5			200,00	80 890 454	●												
160			26				10,5			190,00	80 890 452	●												
160			42,5				10,5			214,00	80 890 456	●												

voor basisbreedte	A	A <sub>1</sub>	D	D <sub>1</sub>	D <sub>2</sub>	E	M	M <sub>1</sub>	M <sub>2</sub>	EUR	Y4	NCG	H5G / -S / -Z	X5G-Z / -S	ESG 4	ESG 5	HDG 2	ZSG 4	ZSG mini	DSG 4	Verso	HSG	
125							10,5			1.030,00	80 890 399	●											

**80 890 399:** Set met 7 sets à 2 stuks werkstuk onderlegplaten in houten kist (exclusief 80 890 422)

## Werkstuk onderlegplaten, getraapt

- ▲ gehard en geslepen
- ▲ worden met behulp van veren in de basisplaat geklemd
- ▲ levering in set van 2 stuks
- ▲ prijs per set

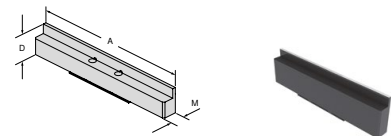

voor basisbreedte	A	A <sub>1</sub>	D	D <sub>1</sub>	D <sub>2</sub>	E	M	M <sub>1</sub>	M <sub>2</sub>	EUR	Y4	NCG	H5G / -S / -Z	X5G-Z / -S	ESG 4	ESG 5	HDG 2	ZSG 4	ZSG mini	DSG 4	Verso	HSG			
125			11				10,5			153,00	80 901 703				●										
125			21				10,5			157,00	80 901 704				●										
125			25				10,5			153,00	80 901 705				●										
160			26				10,5			186,00	80 901 700				●										
125			32,5				10,5			153,00	80 901 706				●										
160			39				10,5			196,00	80 901 701				●										
160			42,5				10,5			210,00	80 901 702				●										

## Werkstuk onderlegplaten, getraapt

- ▲ gehard en geslepen
- ▲ worden met behulp van veren in de basisplaat geklemd
- ▲ levering in set van 2 stuks
- ▲ prijs per set

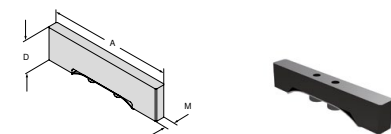

voor basisbreedte	A	A <sub>1</sub>	D	D <sub>1</sub>	D <sub>2</sub>	E	M	M <sub>1</sub>	M <sub>2</sub>	EUR	Y4	NCG	H5G / -S / -Z	X5G-Z / -S	ESG 4	ESG 5	HDG 2	ZSG 4	ZSG mini	DSG 4	Verso	HSG				
80			15				10,5			127,00	80 901 707				●											
80			20				10,5			127,00	80 901 708				●											

# Overzicht werkstuk onderlegplaten

## Werkstuk onderlegplaten, getrapt

- ▲ gehard en geslepen
- ▲ worden met behulp van veren in de basisplaat geklemd
- ▲ levering in set van 2 stuks
- ▲ prijs per set

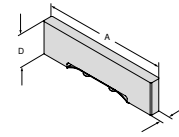

voor basisbreedte	A	A <sub>1</sub>	D	D <sub>1</sub>	D <sub>2</sub>	E	M	M <sub>1</sub>	M <sub>2</sub>	EUR	Y4	NCG	H5G / -S / -Z	X5G-Z / -S	ESG 4	ESG 5	HDG 2	ZSG 4	ZSG mini	DSG 4	Verso	HSG			
125			15				10,5			157,00	80 906 715														
125			22				10,5			157,00	80 906 722														●
125			25				10,5			157,00	80 906 725														●
125			32,5				10,5			157,00	80 906 732														●

## Werkstuk onderlegplaten, getrapt

- ▲ gehard en geslepen
- ▲ worden met behulp van veren in de basisplaat geklemd
- ▲ prijs per 2 stuks

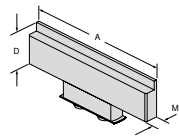

voor basisbreedte	A	A <sub>1</sub>	D	D <sub>1</sub>	D <sub>2</sub>	E	M	M <sub>1</sub>	M <sub>2</sub>	EUR	Y4	NCG	H5G / -S / -Z	X5G-Z / -S	ESG 4	ESG 5	HDG 2	ZSG 4	ZSG mini	DSG 4	Verso	HSG			
100			16				10,5			131,00	80 892 401														
100			25,5				10,5			131,00	80 892 411														
100			29,5				10,5			131,00	80 892 421														
125			11				10,5			157,00	80 892 390														
125			16				10,5			157,00	80 892 391														
125			21				10,5			157,00	80 892 392														
125			26				10,5			157,00	80 892 393														
125			29				10,5			157,00	80 892 394														
125			32,5				10,5			157,00	80 892 395														
125			36				10,5			157,00	80 892 396														
160			26				10,5			190,00	80 892 403														
160			39				10,5			200,00	80 892 413														
160			42,5				10,5			214,00	80 892 423														

voor basisbreedte	A	A <sub>1</sub>	D	D <sub>1</sub>	D <sub>2</sub>	E	M	M <sub>1</sub>	M <sub>2</sub>	EUR	Y4	NCG	H5G / -S / -Z	X5G-Z / -S	ESG 4	ESG 5	HDG 2	ZSG 4	ZSG mini	DSG 4	Verso	HSG		
125							10,5			1.030,00	80 892 399							●						

**80 892 399:** Set met 7 sets à 2 stuks werkstuk onderlegplaten in houten kist

## Magnetische werkstuk onderleglijsten, set



- ▲ met vrije ruimte aan de onderzijde
- ▲ flexibel en doordacht spannen
- ▲ hoogtenauwkeurigheid +/- 0,01 mm
- ▲ met behulp van magneetklemming, eenvoudig en snel gemonteerd

## Overzicht werkstuk onderlegplaten

### Magnetische werkstuk onderleglijsten, set

- ▲ roestvrij verenstaal
- ▲ ingeperste magneten
- ▲ levering in set: 5 paar á 2 stuks
- ▲ prijs per set



A	D	M	EUR	Y4	NCG	H5G /-S /-Z	X5G-Z /-S	ESG 4	ESG 5	HDG 2	ZSG 4	ZSG mini	DSG 4	Verzo	HSG
80	5 / 10 / 15 / 20 / 22	2,5	297,00	80 878 79800	●	●	●	●	●	●	●	●	●	●	●
125	8 / 12 / 15 / 20 / 22	2,5	334,00	80 878 79700	●	●	●	●	●	●	●	●	●	●	●
125	8 / 12 / 20 / 25 / 27	2,5	334,00	80 878 79900	●	●	●	●	●	●	●	●	●	●	●

### Magnetische werkstuk onderleglijsten, set

- ▲ Roestvrij verenstaal
- ▲ Ingeperste magneten
- ▲ Levering in set: 5 paar á 2 stuks
- ▲ Prijs per set



A	D	M	EUR	Y4	NCG	H5G /-S /-Z	X5G-Z /-S	ESG 4	ESG 5	HDG 2	ZSG 4	ZSG mini	DSG 4	Verzo	HSG
100	12 / 20 / 25 / 30 / 32	2,5	325,00	80 892 79700	●	●	●	●	●	●	●	●	●	●	●
125	12 / 25 / 30 / 35 / 37	2,5	342,00	80 892 79800	●	●	●	●	●	●	●	●	●	●	●
160	15 / 30 / 40 / 45 / 47	2,5	360,00	80 892 79900	●	●	●	●	●	●	●	●	●	●	●

### Magnetische werkstuk onderleglijsten, set

- ▲ Roestvrij verenstaal
- ▲ Ingeperste magneten
- ▲ Levering in set: 5 paar á 2 stuks
- ▲ prijs per set



A	D	M	EUR	Y4	NCG	H5G /-S /-Z	X5G-Z /-S	ESG 4	ESG 5	HDG 2	ZSG 4	ZSG mini	DSG 4	Verzo	HSG
125	9 / 22 / 27 / 32 / 34	2,5	334,00	80 901 79900	●	●	●	●	●	●	●	●	●	●	●

# Overzicht werkstuk onderlegplaten

## Magnetische werkstuk onderleglijsten

▲ prijs per paar

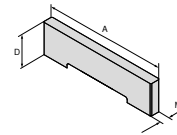

A	D	M	EUR	Y4	NCG	H5G / -S / -Z	X5G-Z / -S	ESG 4	ESG 5	HDG 2	ZSG 4	ZSG mini	DSG 4	Verfo	HSG
80	5	2,5	68,00	80 892 79600											
80	10	2,5	68,00	80 892 79500											
80	15	2,5	68,00	80 892 79400											
80	20	2,5	68,00	80 892 79300											
80	22	2,5	68,00	80 892 79200											
100	12	2,5	71,30	80 892 79100											
100	20	2,5	71,30	80 892 79000											
100	25	2,5	71,30	80 892 78900											
100	27	2,5	71,30	80 892 78800											
100	29	2,5	71,30	80 892 78700											
100	30	2,5	71,30	80 892 78600											
100	31	2,5	71,30	80 892 78500											
100	32	2,5	71,30	80 892 78400											
125	8	2,5	74,50	80 892 78300											
125	9	2,5	74,50	80 892 78200											
125	10	2,5	74,50	80 892 78100											
125	12	2,5	74,50	80 892 78000											
125	15	2,5	74,50	80 892 77900											
125	20	2,5	74,50	80 892 77800											
125	22	2,5	74,50	80 892 77700											
125	23	2,5	74,50	80 892 77600											
125	25	2,5	74,50	80 892 77500											
125	27	2,5	74,50	80 892 77400											
125	30	2,5	74,50	80 892 77300											
125	31	2,5	74,50	80 892 77200											
125	32	2,5	74,50	80 892 77100											
125	33	2,5	74,50	80 892 77000											
125	34	2,5	74,50	80 892 76900											
125	35	2,5	74,50	80 892 76800											
125	36	2,5	74,50	80 892 76700											
125	37	2,5	74,50	80 892 76600											
160	15	2,5	81,00	80 892 76500											
160	22	2,5	81,00	80 892 76400											
160	30	2,5	81,00	80 892 76300											
160	37	2,5	81,00	80 892 76200											
160	40	2,5	81,00	80 892 76100											
160	41	2,5	81,00	80 892 76000											
160	42	2,5	81,00	80 892 75900											
160	43	2,5	81,00	80 892 75800											
160	44	2,5	81,00	80 892 75700											
160	45	2,5	82,00	80 892 75600											
160	46	2,5	81,00	80 892 75500											
160	47	2,5	81,00	80 892 75400											

## Werkstukaanslag, magnetisch

leveromvang:  
inclusief aanslagpen 50 mm / 100 mm



voor breedte mm	grootte	80 892 ...
		EUR Y4
80/100/125/160	60x15	113,00 23800
80/100/125/160	115x15	164,00 23900

## Verlenging voor werkstukaanslag, magnetisch

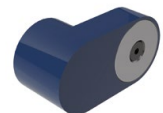

voor breedte mm	grootte	80 892 ...
80/100/125/160	68x30 mm	EUR Y4 87,40 25400



## Overzicht algemene toebehoren

### Uitricht- en centreerset voor T-moeren

▲ prijs per stuk



80 897 ...

l mm	voor gleuf-breedte mm	EUR Y4	
100	14	57,10	114
100	16	57,10	116
100	18	57,10	118

### Uitricht- en centreerset

▲ prijs per stuk

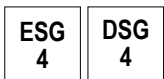

80 906 ...

l mm	voor gleuf-breedte mm	EUR Y4	
80	12	59,50	812
80	14	59,50	814
80	16	59,50	816
80	18	59,50	818

### Opspanbouten set voor T-gleuf voor MNG

▲ prijs per 2 stuks



80 899 ...

voor breedte mm	G	EUR Y4	
12	M10	15,20	312
14	M12	15,20	314
16	M12	20,50	316
18	M12	26,00	318

### Werkstukaanslag



80 892 ...

EUR  
Y4  
81,70 400

### Werkstukaanslag



80 895 ...

EUR  
Y4  
44,80 010

### Werkstukaanslag



80 884 ...

EUR  
Y4  
43,70 400

## Overzicht algemene toebehoren

### Reserve veerblad

- ▲ prijs per stuk
- ▲ voor neertrekbecken en tussenbecken

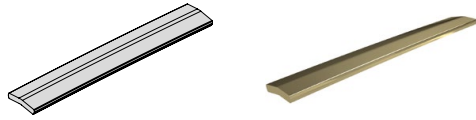

voor breedte mm	80 892 ... EUR Y4	
100	23,90	430
125	24,90	431
160	27,10	432

### Klemvingers

- ▲ prijs per 2 stuks

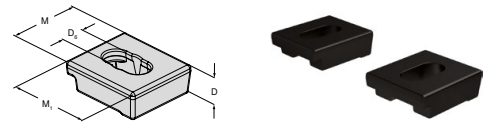

D mm	D <sub>s</sub> mm	M mm	M <sub>1</sub> mm	80 890 ... EUR Y4	
20	16	50	57	38,10	315

# Overzicht spanhendels

## Knie spansleutel

▲ zonder dop



Moment in Nm	vierkant	DRVS	EUR	Y4	NCG	H5G / -S / -Z	X5G-Z / -S	ESG 4	ESG 5	HDC 2	ZSG 4	ZSG mini	DSG 4	Verzo	HSG	MNG	MNG mini
	1/2"		76,10	80 891 600				●			●						

## Momentsleutel

▲ zonder inbusdop



Moment in Nm	vierkant	DRVS	EUR	Y4	NCG	H5G / -S / -Z	X5G-Z / -S	ESG 4	ESG 5	HDC 2	ZSG 4	ZSG mini	DSG 4	Verzo	HSG	MNG	MNG mini
10 - 100	1/2"		280,00	80 884 502				●			●	●	●				
20 - 200	1/2"		280,00	80 884 504				●			●	●	●				

## Momentsleutel

▲ zonder dop



Moment in Nm	vierkant	DRVS	EUR	Y4	NCG	H5G / -S / -Z	X5G-Z / -S	ESG 4	ESG 5	HDC 2	ZSG 4	ZSG mini	DSG 4	Verzo	HSG	MNG	MNG mini
5 - 50	3/8"		280,00	80 884 402								●		●		●	

## Bedieningsset

▲ Momentsleutel inclusief dopsleutel, opsteeksleutel SW10 en 1/2" verlengstuk



Moment in Nm	vierkant	DRVS	EUR	Y4	NCG	H5G / -S / -Z	X5G-Z / -S	ESG 4	ESG 5	HDC 2	ZSG 4	ZSG mini	DSG 4	Verzo	HSG	MNG	MNG mini
8 - 50	3/8"	10	329,00	80 899 410												●	

# Overzicht spanhendels

## Inbusdop

▲ voor vierkant 1/2" of 3/8"



Moment in Nm	vierkant	DRVS	EUR	Y4	NCG	H5G / -S / -Z	X5G-Z / -S	ESG 4	ESG 5	HDC 2	ZSG 4	ZSG mini	DSG 4	Veriso	HSG	MNG	MNG mini
	3/8"	5	18,20	80 877 105													
	3/8"	6	18,20	80 877 10600													
	3/8"	8	18,20	80 877 108										•		•	•
	1/2"	8	18,20	80 877 208													
	1/2"	10	18,20	80 877 210													
	1/2"	14	18,20	80 877 214			•										

## Dop

▲ voor vierkant 1/2" of 3/8"



Moment in Nm	vierkant	DRVS	EUR	Y4	NCG	H5G / -S / -Z	X5G-Z / -S	ESG 4	ESG 5	HDC 2	ZSG 4	ZSG mini	DSG 4	Veriso	HSG	MNG	MNG mini
	3/8"	7	18,20	80 875 107													
	3/8"	11	18,20	80 875 11100								•					
	3/8"	12	18,20	80 875 112				•			•		•				
	1/2"	12	18,20	80 875 212				•			•		•				
	1/2"	14	18,20	80 875 214				•			•		•				

## Overzicht bouten

### Bevestigingsbout voor opzetbekken

▲ DIN EN ISO 4762 (1998-02)



voor basisbreedte	G	J <sub>17</sub>	EUR	Y4	NCG	H5G / -S / -Z	X5G-Z / -S	ESG 4	ESG 5	HDG 2	ZSG 4	ZSG mini	DSG 4	Verzo	HSG	MNG	MNG mini
	M8x12		1,20	80 892 296	•	•				•	•						
	M6x8		1,20	80 895 013								•		•			

### Bevestigingsbout met lage kop voor verwisselbare bekken

▲ vlg. DIN7984 (1985-05)



voor basisbreedte	G	J <sub>17</sub>	EUR	Y4	NCG	H5G / -S / -Z	X5G-Z / -S	ESG 4	ESG 5	HDG 2	ZSG 4	ZSG mini	DSG 4	Verzo	HSG	MNG	MNG mini
	M8x10		1,20	80 889 950	•	•				•	•						

### Bevestigingsbout voor systeembekken

▲ prijs per stuk



voor basisbreedte	G	J <sub>17</sub>	EUR	Y4	NCG	H5G / -S / -Z	X5G-Z / -S	ESG 4	ESG 5	HDG 2	ZSG 4	ZSG mini	DSG 4	Verzo	HSG	MNG	MNG mini
	M12x20		1,20	80 890 630	•	•											
	M12x40		2,30	80 890 632	•	•											

### Cilindrische bout met binnenzeskant

▲ DIN 912



voor basisbreedte	G	J <sub>17</sub>	EUR	Y4	NCG	H5G / -S / -Z	X5G-Z / -S	ESG 4	ESG 5	HDG 2	ZSG 4	ZSG mini	DSG 4	Verzo	HSG	MNG	MNG mini
	M12x45		2,30	80 899 124												•	

### Pasbouten

▲ prijs per 2 stuks



voor basisbreedte	G	J <sub>17</sub>	EUR	Y4	NCG	H5G / -S / -Z	X5G-Z / -S	ESG 4	ESG 5	HDG 2	ZSG 4	ZSG mini	DSG 4	Verzo	HSG	MNG	MNG mini
100	M12x38	12	45,70	80 890 313	•			•									
125 / 160	M16x55	16	60,80	80 890 314	•												

# Overzicht bouten

## Pasbouten

▲ prijs voor 2 stuks



voor basisbreedte	G	J <sub>17</sub>	EUR	Y4	NCG	H5G / -S / -Z	X5G-Z / -S	ESG 4	ESG 5	HDG 2	ZSG 4	ZSG mini	DSG 4	Verso	HSG	MING	MING mini	
125	M12x45	12	26,20	80 895 019	●	●	●	●	●	●	●	●	●	●	●	●	●	●

## Opspanbouten en T-moeren

▲ voor bevestiging van de klemvinger

▲ prijs voor 2 stuks



voor T-sleufbreedte	G	J <sub>17</sub>	EUR	Y4	NCG	H5G / -S / -Z	X5G-Z / -S	ESG 4	ESG 5	HDG 2	ZSG 4	ZSG mini	DSG 4	Verso	HSG	MING	MING mini
12	M10		24,30	80 890 308	●	●	●	●	●	●	●	●	●	●	●	●	●
14	M12		24,30	80 890 309	●	●	●	●	●	●	●	●	●	●	●	●	●
16	M14		25,20	80 890 310	●	●	●	●	●	●	●	●	●	●	●	●	●
18	M16		26,30	80 890 311	●	●	●	●	●	●	●	●	●	●	●	●	●

## Bevestigingsbouten voor ronde klemvingers, T-gleuf

▲ incl. T-moer en ring

▲ prijs per 2 stuks



voor T-sleufbreedte	G	J <sub>17</sub>	EUR	Y4	NCG	H5G / -S / -Z	X5G-Z / -S	ESG 4	ESG 5	HDG 2	ZSG 4	ZSG mini	DSG 4	Verso	HSG	MING	MING mini
12	M10		15,80	80 899 112										●	●	●	●
14	M12		15,80	80 899 114										●	●	●	●
16	M12		17,30	80 899 116										●	●	●	●
18	M12		18,50	80 899 118										●	●	●	●

## Pasblokken incl. bout

▲ prijs per paar van 2 stuks

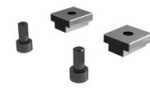

voor T-sleufbreedte	G	J <sub>17</sub>	EUR	Y4	NCG	H5G / -S / -Z	X5G-Z / -S	ESG 4	ESG 5	HDG 2	ZSG 4	ZSG mini	DSG 4	Verso	HSG	MING	MING mini
12	M6		91,20	80 898 412	●	●	●	●	●	●	●	●	●	●	●	●	●
14	M6		91,20	80 898 414	●	●	●	●	●	●	●	●	●	●	●	●	●
16	M6		91,20	80 898 416	●	●	●	●	●	●	●	●	●	●	●	●	●
18	M6		91,20	80 898 418	●	●	●	●	●	●	●	●	●	●	●	●	●