



ZSG 1

MNG mini
CERATIZIT GROUP

ZSG mini
CERATIZIT GROUP

Nye produkter til opspændingsteknik

NEW Mekanisk Nulpunktsspændesystem – MNG mini



149-151

**MNG
mini**

Vægtoptimerede konsoller, pyramider og fastspændingstårne med integreret nulpunktsspændesystem til små skruestik.

NEW CentriClamp – ZSG mini



92-100

**ZSG
mini**

ZSG mini er ideel til opspænding af små emner!

NEW PolyClamp – Verso

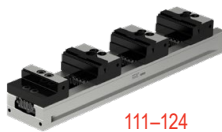

111-124

Verso

Den nye fleksible multiskruestik med hurtigskift-bakke-system til mange små, men også store emner!

Boring og hulbearbejdning

1 HSS-bor

2 Hårdmetal bor

3 Bor med vendeskær

4 Rivaler og forsænkere

5 Udboreværktøjer

Gevindbearbejdning

6 Gevindtappe og -formere

7 Cirkulære- og gevindfræsere

8 Gevindrejeværktøjer

Drejning

9 Drejning med vendeskær

10 Multifunktionsværktøjer – EcoCut og FreeTurn

11 Stikværktøjer

12 Miniaturedrejeværktøjer

Fræsning

13 HSS-fræsere

14 Hårdmetal fræsere

15 Fræsning med vendeskær

Opspændingsteknik

16 Værktøjsholdere og tilbehør

17 Emneopspænding

18 Materialeeksempler og liste over artikelnumre

Indholdsfortegnelse

PolyClamp – Verso	4
Oversigt spændesystemer	5
Toolfinder – spændesystemer	6–9
Produktprogram	10–183
Oversigt almene topbakker	164–173
Oversigt emnestøtter	174–177
Oversigt generelt tilbehør	178+179
Oversigt spændearm	180+181
Oversigt skruer	182+183

WNT \ Performance

Førsteklasses kvalitetsværktøj.

Serien **WNT Performance** er værktøj af højeste kvalitet kendetegnet ved en fremragende ydeevne og effektivitet. Hvis du vil sætte de højeste standarder og opnå de bedste resultater i din produktion, anbefaler vi værktøjsserien WNT Performance.

PolyClamp – Verso

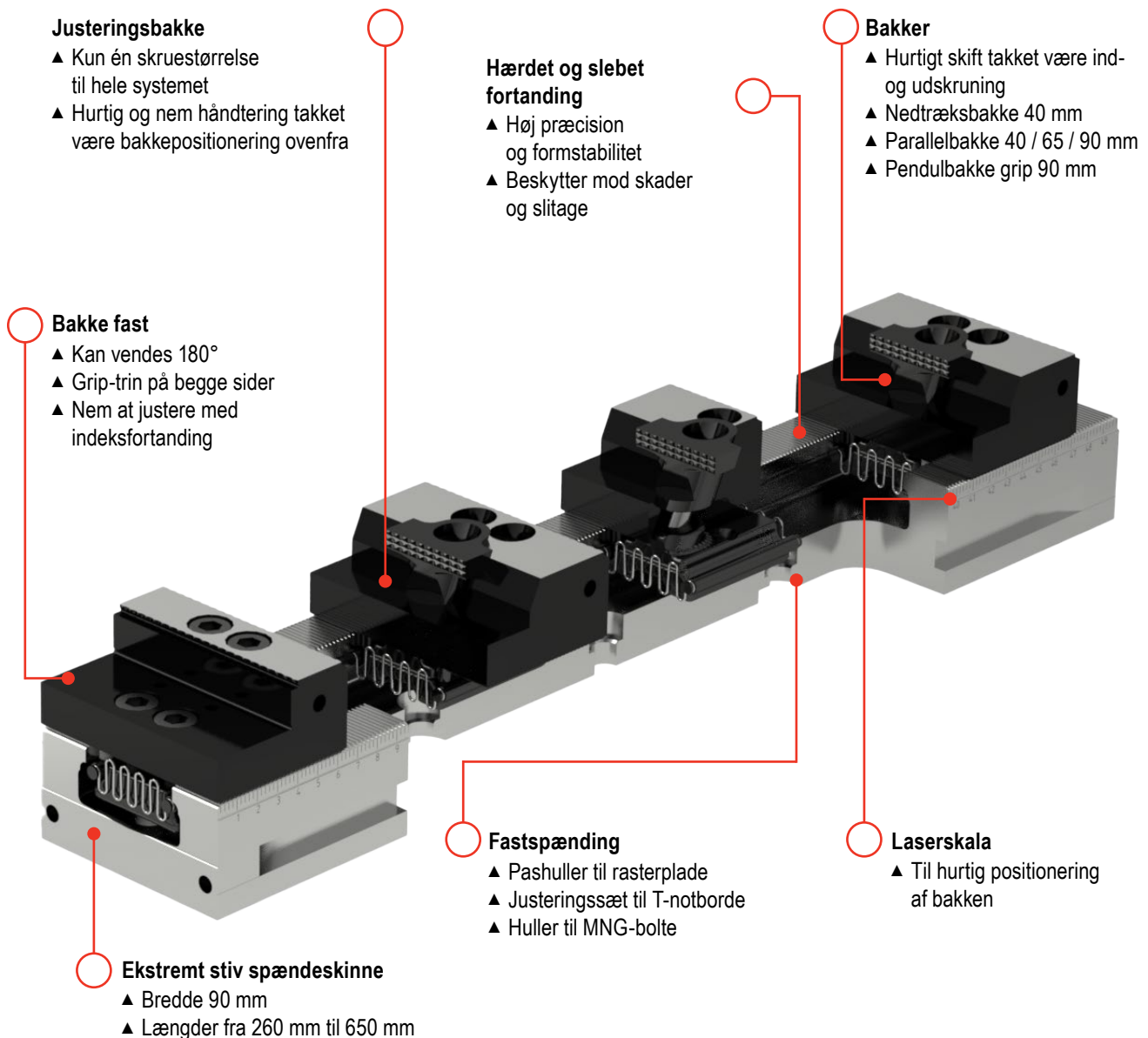

Oversigt spændesystemer

SoloClamp – Enkel skruestik

- ▲ Kraftforstærkede systemer NCG, HDG 2 og H5G
- ▲ Fastbakke som reference
- ▲ Høj gentagelsesnøjagtighed
- ▲ Rigtig god vinkelnøjagtighed



» Høj præcision og kraftforstærkning

CentriClamp – Centrér skruestik

- ▲ Symmetrisk opspænding
- ▲ Meget god adgang til 5-sidet bearbejdning
- ▲ Emne-nulpunkt altid i midten (centreret)
- ▲ Høj gentagelsesnøjagtighed



» Høj processikkerhed med indkapslet system

PolyClamp – Multiskruestik

- ▲ Hurtig emneskift
- ▲ Multifunktionel anvendelse
- ▲ Optimal udnyttelse af maskinbordet
- ▲ Høj gentagelsesnøjagtighed



» Optimering af maskinens driftstider

Stationær trebakkepatron – SBF 3

- ▲ Velegnet til 3/5-akset bearbejdning af runde komponenter
- ▲ kompatibel med PNG- og MNG-nulpunkt-spændesystemer
- ▲ Kilestangsdrev
- ▲ Hærdet og solid grundkrop
- ▲ Optimeret smøresystem



» Den perfekte opspænding til runde komponenter

Nulpunkts paletter

- ▲ Nulpunkt-spændesystem
- ▲ Nulpunkt-spændesystem rasterplade
- ▲ MNG – mekanisk nulpunkt-spændesystem
- ▲ PNG – pneumatisk nulpunkt-spændesystem



» Reduktion af opstillingstider

Opspændingstårn

- ▲ Dobbeltsidet opspændingstårn
- ▲ Trekantet opspændingstårn
- ▲ Kryds-opspændingstårn
- ▲ Flersidet-opspændingstårn



» Let automatisering







Forskellige opspændingstårne findes i vores onlineshop på cuttingtools.ceratzit.com





Toolfinder spændesystemer

Type	Beskrivelse	3-akset	4-akset	5-akset	
SoloClamp – Enkel skruestik	NCG 	<ul style="list-style-type: none"> ▲ 160° hurtigspænding ▲ Hurtig af- og påmontering af spindelmodulet ▲ Opspænding med spændtryk 	✓	✓	
	NCG 5A 	<ul style="list-style-type: none"> ▲ 160° hurtigspænding ▲ Til 5-akset bearbejdning ▲ Opspænding med spændtryk 	✓		✓
	H5G 	<ul style="list-style-type: none"> ▲ Hurtigspænding med håndtag ▲ 5-akset kraft skruestik ▲ 100 % indkapslet 	✓		✓
	H5G -Z 	<ul style="list-style-type: none"> ▲ Hurtigspænding med håndtag ▲ 5-akset kraft skruestik ▲ 100 % indkapslet ▲ Med mobil fastbakke 	✓		✓
	X5G -Z 	<ul style="list-style-type: none"> ▲ 100 % indkapslet ▲ Bedste tilgængelighed ▲ 5- og 6-sidet bearbejdning mulig ▲ Hurtigskift-bakker uden brug af værktøj 	✓		✓
	ESG 4 	<ul style="list-style-type: none"> ▲ 100 % indkapslet ▲ Præcis grundkrop ▲ Høj spændkraft ▲ Stort opspændingsområde 	✓	✓	✓
	ESG 5 	<ul style="list-style-type: none"> ▲ Ny udførelse af den indkapslede center skruestik ZSG 4 som enkel skruestik ▲ Samme dimensioner som ZSG 4 	✓	✓	✓
	HDG 2 	<ul style="list-style-type: none"> ▲ Mekanisk kraftoverførsel ▲ Spændkraft med kun én håndsvings omdrejning ▲ Trinløs spændkraftindstilling 	✓		
CentriClamp – Center skruestik	ZSG 4 	<ul style="list-style-type: none"> ▲ Kuglelejret, sløfri spindel ▲ Høj præcision, spændkraft og processikkerhed ▲ Gentagelsesnøjagtighed $\pm 0,01$ mm 	✓	✓	✓
	ZSG mini 	<ul style="list-style-type: none"> ▲ Hurtigskift-bakker uden værktøj ▲ Kompakt og præcis ▲ Bedste tilgængelighed fra alle sider ▲ Rustfri og hærdet grundkrop 	✓	✓	✓

	Bakkebredde i mm	Grundkrop længde i mm	Maks. opspændingsområde i mm	Kubiske emner	Asymmetriske emner	Runde emner	Maks. spændkraft i kN	Side
	100 125 160	305 390 530	245 343 506	✓	✓	✓	30 40 40	10-21
	100 125	305 390	199 269	✓		✓	18 24	13-21
	125	300	249	✓	✓	✓	40	22-36
	125	330 430 500 630	396 466 578	✓	✓	✓	40	26-36
	125	330 430 500 630 800	80-210 80-310 80-380 80-510 80-688	✓	✓	✓	40	37
	80 125 160	214 362 480	192 308 434	✓	✓	✓	25 40 50	49-58
	80 125 160	130+190 160+235+300 280+480	63-171 84-281 125-448	✓	✓	✓	35 35 50	59-66
	100 125 160	342 400 544	278 338 470	✓		✓	30 40 60	68-71
	80 125 160	130+190 160+235+300 280+480	121-185 163-303 134-462	✓	✓	✓	25 40 50	72-90
	45 70	80 100	7-77	✓	✓	✓	16	92-100



Toolfinder spændesystemer

Type	Beskrivelse	3-akset	4-akset	5-akset
PolyClamp – Multiskruestik	DSG 4  <ul style="list-style-type: none"> ▲ Hurtig på- og afmontering ▲ Flexibelt spændesystem ▲ Kan omdannes til enkel skruestik 	✓	✓	✓
	Verso  <ul style="list-style-type: none"> ▲ Variabelt spændesystem ▲ Opspænder små samt store komponenter ▲ Innovativt multispændesystem 	✓	✓	✓
Stationær trebakkepatron	SBF 3  <ul style="list-style-type: none"> ▲ Eget til 3/5-akset bearbejdning af runde komponenter ▲ Kompatibel med PNG- og MNG-nulpunkt-spændesystemer 	✓		✓
	 <ul style="list-style-type: none"> ▲ Eget til 3/5-akset bearbejdning af runde komponenter ▲ Kompatibel med PNG- og MNG-nulpunkt-spændesystemer 	✓		✓

Type	Beskrivelse	
Nulpunkt-spændesystem	Mekanisk	MNG  <ul style="list-style-type: none"> ▲ Allroundplader til ethvert maskinbord
		MNG mini  <ul style="list-style-type: none"> ▲ Til emneopspænding af små emner
	Pneumatisk	PNG  <ul style="list-style-type: none"> ▲ Processikkerhed via automatisk låsning
Opspændingsstærk	 <ul style="list-style-type: none"> ▲ Optimering af maskinens driftstider 	

Maskinskruestik med håndtag

Boremaskine-skruestik	HSG  <ul style="list-style-type: none"> ▲ Hurtig justering af bakker, kompakt og præcis
-----------------------	--

Bakkebredde i mm	Grundkrop længde i mm	Maks. opspændingsområde i mm	Kubiske emner	Asymmetriske emner	Runde emner	Maks. spændkraft i kN	Side
80	300	102				25	
125	320+390+460 530+600+670+740	114+149+184 219+254+289+324	✓	✓	✓	40	101-110
40 65 90	260 -650	524	✓	✓	✓	30	111-124
	Ø 200	SB-H-bakker 6-180			✓	100	
	Ø 315	SB-H-bakker 12-420			✓	180	125-130
	Mekanisk	Pneumatisk			Bemærkning		Side
	✓						134-148
	✓						149-151
		✓					152-163
	✓				Disse artikler findes i vores onlineshop på cuttingtools.ceratizit.com	 	
	✓						131-133

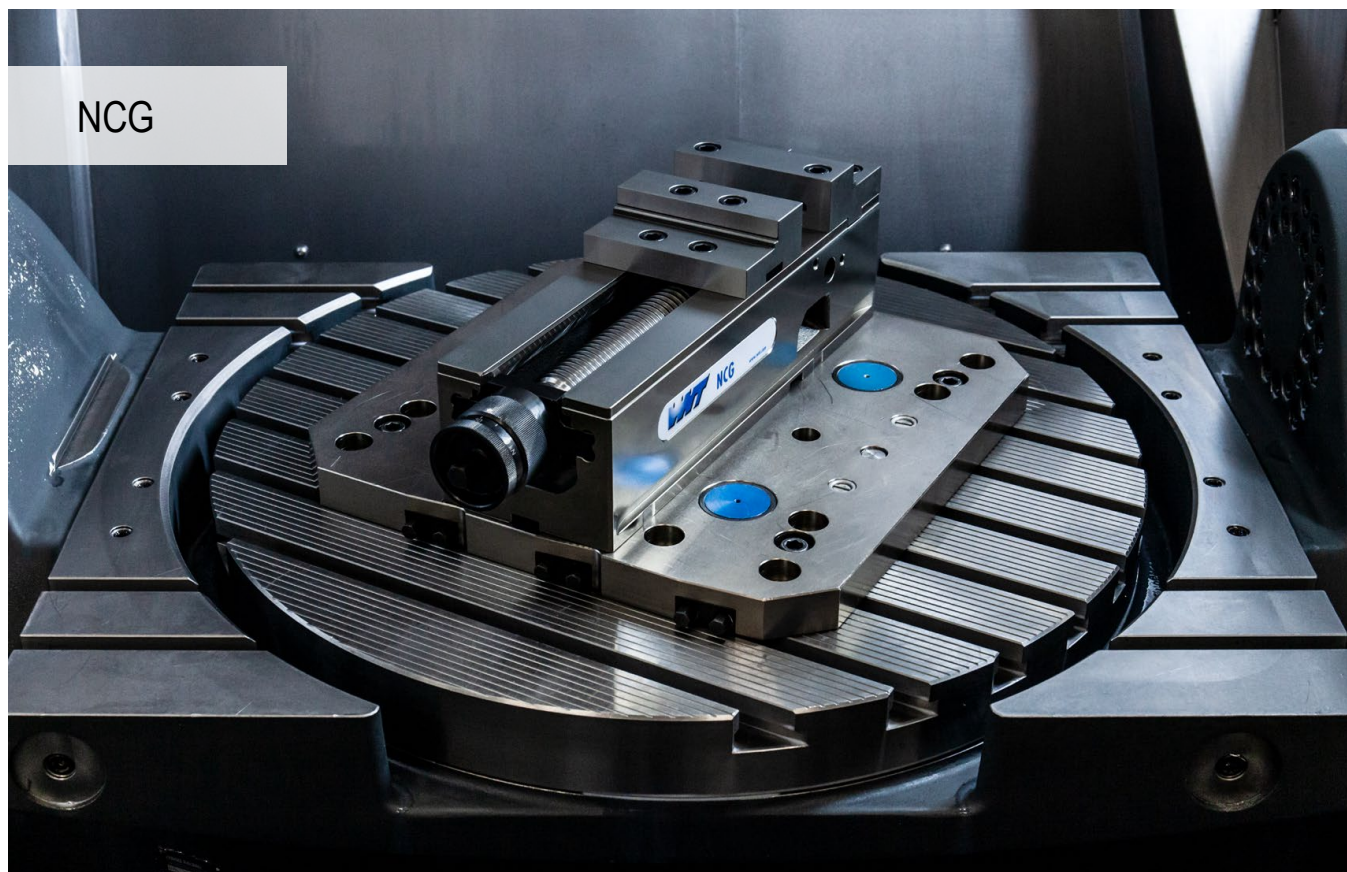

NCG

Systematisk opspænding

Modulopbygget maskinskruestiksystem med spændtryk. Unik, patenteret hurtigspænder håndtag. Mekanisk kraftforstærkning og minimale opsætningstider.

Dine fordele:

- ▲ Håndsving for hurtig justering
- ▲ Hurtig positionering med MNG på maskinbordet uden mellempalette
- ▲ Trinløs kraftindstilling 4-40 kN
- ▲ 160° hurtigspænding
- ▲ Hurtigt og nemt bakkeskift med 4 skruer
- ▲ Nem rengøring takket være hurtig afmontering af hele spindelenheden
- ▲ Omfattende modulopbygget bakke-program



Opspænding/justering:



Opspænding med to passkruer Ø 12_{H7} / M12 (NCG 100) eller Ø 16_{g5} / M16 (NCG 125 / 160)



Justering ved hjælp af præcisions T-not møtrikker 20^{H7} i grundkroppen og opspænding med spændejern



Justering og opspænding med nulpunkt-spændesystem MNG (2-3 antræksbolte)

SoloClamp – NCG

- ▲ NC-skruestik med hurtigspænding med kombi-vendebakke-plus
- ▲ Ekstra gevindhuller muliggør anvendelse af bakker med højden 18 mm og 40 mm

Leveringsomfang:

NC-skruestik med hurtigspænding, inkl. 4 spændejern, 2 x kombi-vendebakke-plus, spændearm inkl. betjeningstilbehør, uden spændeskruer

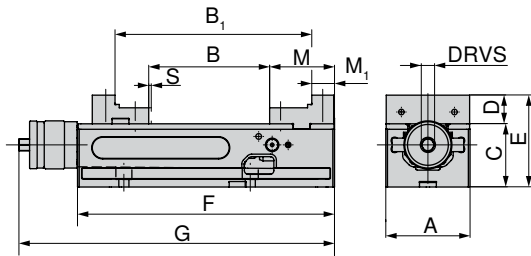

A	B	B ₁	C _{-0.02}	D	E	F	G	M	M ₁	S	DRVS	MXC	WT	80 890 ...	
mm	mm	mm	mm	mm	mm	mm	mm	mm	mm	mm	mm	kN	kg	DKK	
125	0 - 212	96 - 307	100	39	139	390	457	89	39	3	14	4 - 40	34	Y4	12500
														23.263,00	

SoloClamp – NCG

- ▲ NC-skruestik med hurtigspænding med kombi-vendebakke
- ▲ Hurtig 160° håndtagsspænding
- ▲ Hurtig på- og afmontering af spindelmodulet
- ▲ S = Kraftvandring

Leveringsomfang:

NC-skruestik med hurtigspænding, inkl. 4 spændejern, 2-vendebakker (en side med trin, en side glat) spændearm inkl. betjeningstilbehør

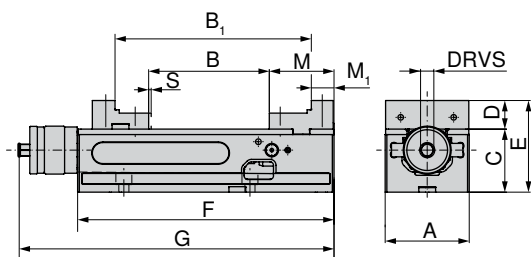
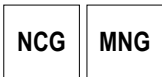

A	B	B ₁	C _{-0.02}	D	E	F	G	M	M ₁	S	DRVS	MXC	WT	80 890 ...	
mm	mm	mm	mm	mm	mm	mm	mm	mm	mm	mm	mm	kN	kg	DKK	
100	0 - 155	91 - 245	75	34	109	305	374	77	27	2,5	14	4 - 30	19	Y4	602
125	0 - 212	96 - 307	100	39	139	390	457	89	39	3	14	4 - 40	34	23.038,00	627
160	0 - 314	113 - 426	115	49	164	530	600	108	52	3	14	4 - 40	68	30.219,00	662

Skruestikguide

Dimensioner	14	Systemtilbehør	16-21
MNG-/PNG-nulpunkt-spændesystem	134-163	Alment tilbehør	164-183

SoloClamp – NCG

- ▲ NC-skruestik med hurtigspænding med standard-vendebakke
- ▲ Hurtig 160° håndtagsspænding
- ▲ Hurtig på- og afmontering af spindelmodul
- ▲ S = Kraftvandring

Leveringsomfang:

NC-skruestik med hurtigspænding, inkl. 4 spændejern, 2 standard-vendebakker (en side med trin, en side glat) spændearm inkl. betjeningsstilbehør

NCG

MNG

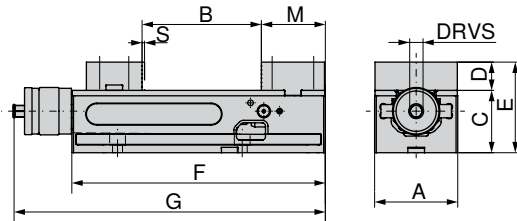

A	B	C _{-0.02}	D	E	F	G	M	S	DRVS	MXC	WT	80 890 ...	
mm	mm	mm	mm	mm	mm	mm	mm	mm	mm	kN	kg	DKK	
100	0 - 155	75	34	109	305	374	77	2,5	14	4 - 30	19,5	19.298,00	600
125	0 - 212	100	39	139	390	457	89	3	14	4 - 40	35,0	22.515,00	625
160	0 - 314	115	49	164	530	600	108	3	14	4 - 40	70,0	29.621,00	660

SoloClamp – NCG

- ▲ NC-skruestik med hurtigspænding med adapter- og pendulbakke
- ▲ Hurtig 160° håndtagsspænding
- ▲ Hurtig på- og afmontering af spindelmodul
- ▲ S = Kraftvandring
- ▲ Nem ræmnespænding
- ▲ Fri positionering af 6-fags vendebakke

Leveringsomfang:

NC-skruestik med hurtigspænding (grundkrop type NCG) med 1 adapterskær fast og 1 pendulbakke, spændearm inkl. betjeningsstilbehør, 4 spændejern, uden 6-dobbelte vendebakker

NCG

MNG

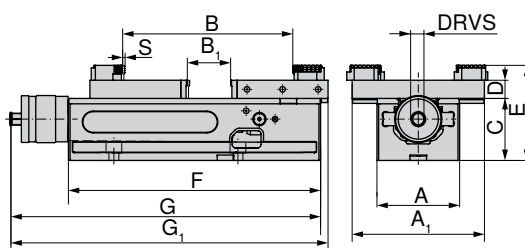

A	A ₁	B	B ₁	C _{-0.02}	D	E	F	G	G ₁	S	DRVS	MXC	WT	80 890 ...	
mm	mm	mm	mm	mm	mm	mm	mm	mm	mm	mm	mm	kN	kg	DKK	
100	160	10 - 230	0 - 77	75	22	115	305	374	383	2,5	14	4 - 30	19	20.720,00	636
125	192	16 - 343	0 - 152	100	22	140	390	457	478	3	14	4 - 40	34	24.086,00	637
160	256	15 - 506	0 - 237	115	22	155	530	600	631	3	14	4 - 40	68	31.790,00	638

Skruestikguide

Dimensioner	14	Systemtilbehør	16-21
MNG-/PNG-nulpunkt-spændesystem	134-163	Alment tilbehør	164-183

SoloClamp – NCG 5A

- ▲ NC-skruestik med hurtigspænding 5A med høje støttebakker
- ▲ Hurtig 160° håndtagsspænding
- ▲ Hurtig på- og afmontering af spindelmodulet
- ▲ S = Kraftvanding
- ▲ Via optimal tilgængelighed ideel til 5-sidet-bearbejdning
- ▲ Bakker til spændeo mrådeudvidelse vendbar
- ▲ Grundkrop 100 mm har 2 noter til forskydning af den faste bakke
- ▲ Grundkrop 125 mm har 3 noter til forskydning af den faste bakke

Leveringsomfang:

NC-skruestik med hurtigspænding, inkl. 2 støttebakke høj, 2 grip-trinbakker 5 mm, 1 spændearm, 4 spændejern

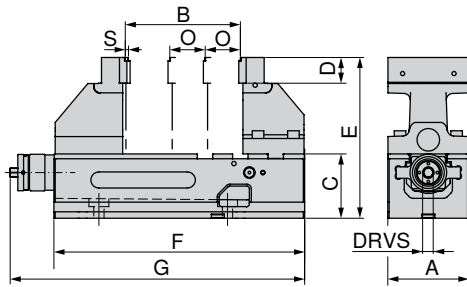

A	B	C	D	E	F	G	O	S	DRVS	MXC	WT	80 890 ...	
mm	mm	mm	mm	mm	mm	mm	mm	mm	mm	kN	kg	DKK	
100	6 - 127	75	35	200	305	374	50	2,5	14	4 - 18 (30)	21,5	24.011,00	605
125	6 - 179	100	40	250	390	457	55	3	14	4 - 24 (40)	42,0	27.751,00	635

Skruestikguide

Dimensioner	14	Dimensionstabeller til de forskellige bakker	15
Systemtilbehør	16-21	MNG-/PNG-nulpunkt-spændesystem	134-163
Alment tilbehør	164-183		

NCG dimensioner

Grundkrop bredde 100 mm

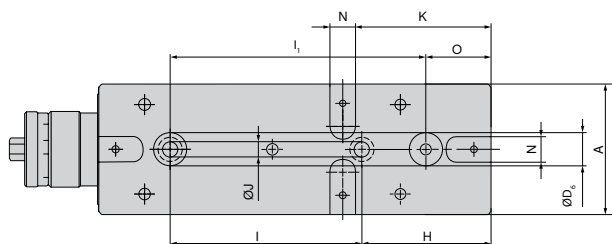

A	H	I _{±0,015}	J _{F7}	K	N _{H7}	O	I _{1±0,015}	D _{6 H7}
mm	mm	mm	mm	mm	mm	mm	mm	mm
100	100	150	12	105	20	50	200	25

Grundkrop bredde 125 mm

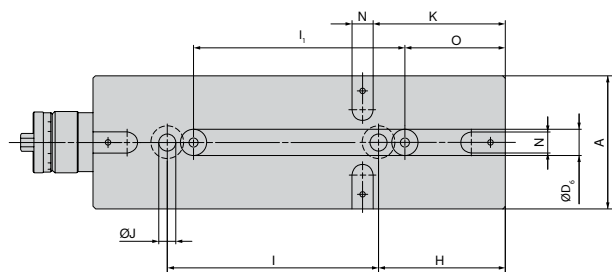

A	H	I _{±0,015}	J _{F7}	K	N _{H7}	O	I _{1±0,015}	D _{6 H7}
mm	mm	mm	mm	mm	mm	mm	mm	mm
125	120	200	16	125	20	95	200	25

Grundkrop bredde 160 mm

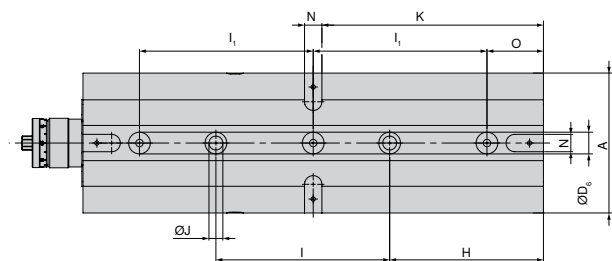

A	H	I _{±0,015}	J _{F7}	K	N _{H7}	O	I _{1±0,015}	D _{6 H7}
mm	mm	mm	mm	mm	mm	mm	mm	mm
160	177	200	16	255	20	65	200	25

NCG 5A Tabel med mål til forskellige bakkeplaceringer

NCG 5A 100 mm

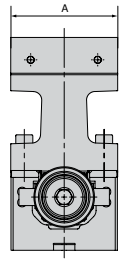
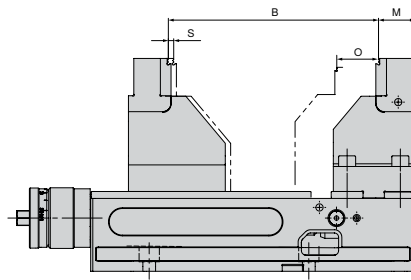
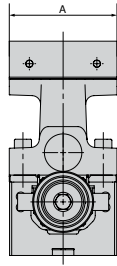
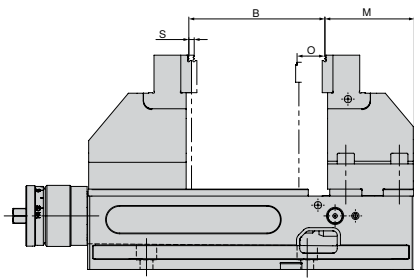

A mm	B mm	M mm	O mm	S mm
100	6 - 127	84,5	50	2,5

A mm	B mm	M mm	O mm	S mm
100	97 - 199	34,5	50	2,5

NCG 5A 125 mm

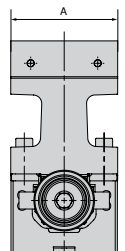
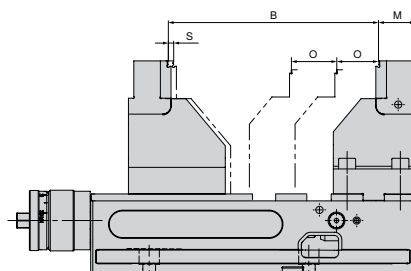
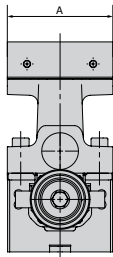
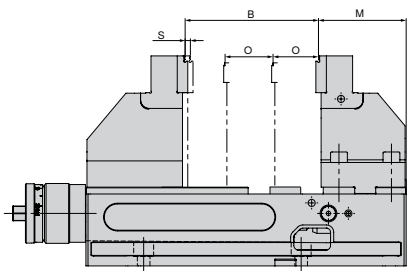

A mm	B mm	M mm	O mm	S mm
125	6 - 182	91	55	3

A mm	B mm	M mm	O mm	S mm
125	117 - 269	36	55	3

Oversigt systembakker

Kombi-vendebakke-plus, fast

- ▲ Til udvidelse af spændeområdet
- ▲ Bakker hærdet
- ▲ Inkl. fastspændingsbolte
- ▲ Pris pr. stk.

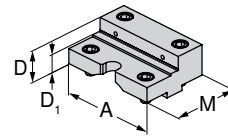

Til skruestikbredde	A	A ₁	D	D ₁	D ₂	E	M	M ₁	M ₂	DKK	Y4	NCG	H5G / -S / -Z	X5G-Z / -S	ESG 4	ESG 5	HDG 2	ZSG 4	ZSG mini	DSG 4	Verso	HSG	
125	125		39,8	22			88			2.820,00		●											

Kombi-vendebakke-plus, bevægelig

- ▲ Til udvidelse af spændeområdet
- ▲ Bakker hærdet
- ▲ Inkl. fastspændingsbolte
- ▲ Pris pr. stk.

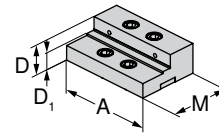

Til skruestikbredde	A	A ₁	D	D ₁	D ₂	E	M	M ₁	M ₂	DKK	Y4	NCG	H5G / -S / -Z	X5G-Z / -S	ESG 4	ESG 5	HDG 2	ZSG 4	ZSG mini	DSG 4	Verso	HSG	
125	125		39,8	22			82			2.820,00		●											

Standard-vendebakke, fast

- ▲ 1 side glat, 1 side riflet
- ▲ Inkl. fastspændingsbolte
- ▲ Pris pr. stk.

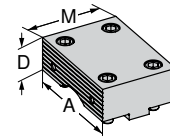

Til skruestikbredde	A	A ₁	D	D ₁	D ₂	E	M	M ₁	M ₂	DKK	Y4	NCG	H5G / -S / -Z	X5G-Z / -S	ESG 4	ESG 5	HDG 2	ZSG 4	ZSG mini	DSG 4	Verso	HSG	
100	100		34				76			1.848,00		●											
125	125		39				88			2.416,00		●											
160	160		49				108			3.044,00		●											

Standard-vendebakke, bevægelig

- ▲ 1 side glat, 1 side riflet
- ▲ Inkl. fastspændingsbolte
- ▲ Pris pr. stk.

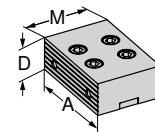

Til skruestikbredde	A	A ₁	D	D ₁	D ₂	E	M	M ₁	M ₂	DKK	Y4	NCG	H5G / -S / -Z	X5G-Z / -S	ESG 4	ESG 5	HDG 2	ZSG 4	ZSG mini	DSG 4	Verso	HSG	
100	100		34				67			1.848,00		●											
125	125		39				82			2.416,00		●											
160	160		49				108			3.044,00		●											

Oversigt systembakker

Kombi-vendebakke, fast

- ▲ Til udvidelse af spændområdet
- ▲ Bakker hærdet
- ▲ Inkl. fastspændingsbolte
- ▲ Pris pr. stk.

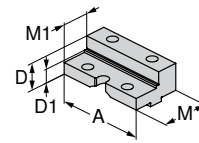

Til skruestikbredde	A	A ₁	D	D ₁	D ₂	E	M	M ₁	M ₂	DKK	Y4	NCG	H5G / -S / -Z	X5G-Z / -S	ESG 4	ESG 5	HDC 2	ZSG 4	ZSG mini	DSG 4	Verso	HSG		
100	100		34	23			76	50		2.132,00	80 890 343	●												
125	125		39	25			88	50		2.715,00	80 890 344	●												
160	160		49	28			108	56		3.336,00	80 890 342	●												

Kombi-vendebakke, bevægelig

- ▲ Til udvidelse af spændområdet
- ▲ Bakker hærdet
- ▲ Inkl. fastspændingsbolte
- ▲ Pris pr. stk.

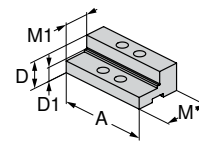

Til skruestikbredde	A	A ₁	D	D ₁	D ₂	E	M	M ₁	M ₂	DKK	Y4	NCG	H5G / -S / -Z	X5G-Z / -S	ESG 4	ESG 5	HDC 2	ZSG 4	ZSG mini	DSG 4	Verso	HSG			
100	100		34	23			67	40		2.132,00	80 890 347	●													
125	125		39	25			82	45		2.715,00	80 890 348	●													
160	160		49	28			108	56		3.336,00	80 890 346	●													

Blød bakke, stål, fast

- ▲ Materiale: 16MnCr5
- ▲ Til fremstilling af formbakker
- ▲ Uden fastspændingsbolte
- ▲ Pris pr. stk.

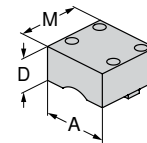

Til skruestikbredde	A	A ₁	D	D ₁	D ₂	E	M	M ₁	M ₂	DKK	Y4	NCG	H5G / -S / -Z	X5G-Z / -S	ESG 4	ESG 5	HDC 2	ZSG 4	ZSG mini	DSG 4	Verso	HSG			
100	100		50				95			1.073,00	80 890 763	●													
125	125		50				110			1.120,00	80 890 764	●													

Blød bakke, stål, bevægelig

- ▲ Materiale: 16MnCr5
- ▲ Til fremstilling af formbakker
- ▲ Uden fastspændingsbolte
- ▲ Pris pr. stk.

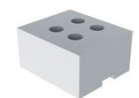
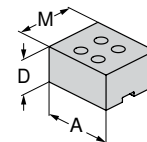

Til skruestikbredde	A	A ₁	D	D ₁	D ₂	E	M	M ₁	M ₂	DKK	Y4	NCG	H5G / -S / -Z	X5G-Z / -S	ESG 4	ESG 5	HDC 2	ZSG 4	ZSG mini	DSG 4	Verso	HSG			
100	100		50				85			1.076,00	80 890 767	●													
125	125		50				100			1.130,00	80 890 768	●													

Oversigt systembakker

5A-støttebakke, fast

- ▲ Pris pr. stk.
- ▲ Med trinbakke grip 5 mm

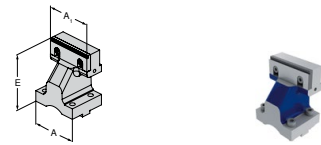

Til skruestikbredde	A	A ₁	D	D ₁	D ₂	E	M	M ₁	M ₂	DKK	Y4	NCG	H5G / -S / -Z	X5G-Z / -S	ESG 4	ESG 5	HDG 2	HDG 4	ZSG 4	ZSG mini	DSG 4	Verso	HSG	
100	100	100				125				4.144,00	80 890 364	●												
125	125	125				150				4.982,00	80 890 366	●												

5A-støttebakke, bevægelig

- ▲ Pris pr. stk.
- ▲ Med trinbakke grip 5 mm

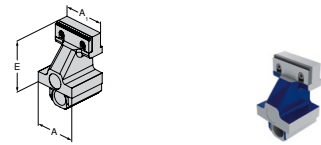

Til skruestikbredde	A	A ₁	D	D ₁	D ₂	E	M	M ₁	M ₂	DKK	Y4	NCG	H5G / -S / -Z	X5G-Z / -S	ESG 4	ESG 5	HDG 2	HDG 4	ZSG 4	ZSG mini	DSG 4	Verso	HSG	
100	100	100				125				4.406,00	80 890 365	●												
125	125	125				150				5.460,00	80 890 367	●												

Adapterbakke, fast

- ▲ Til fastholdelse af 6-fags vendebakker
- ▲ Pris pr. stk.
- ▲ Inkl. 6 dækskruer

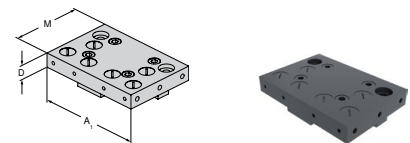

Til skruestikbredde	A	A ₁	D	D ₁	D ₂	E	M	M ₁	M ₂	DKK	Y4	NCG	H5G / -S / -Z	X5G-Z / -S	ESG 4	ESG 5	HDG 2	HDG 4	ZSG 4	ZSG mini	DSG 4	Verso	HSG	
100	100	160	22				110			2.079,00	80 890 321	●												
125	125	192	22				130			2.970,00	80 890 337	●												
160	160	256	22				170			3.897,00	80 890 339	●												

Pendulbakke, bevægelig

- ▲ Til fastholdelse af 6-fags vendebakker
- ▲ Pris pr. stk.
- ▲ Inkl. 6 dækskruer (ved A = 100 mm, 4 stk.)

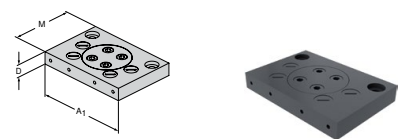

Til skruestikbredde	A	A ₁	D	D ₁	D ₂	E	M	M ₁	M ₂	DKK	Y4	NCG	H5G / -S / -Z	X5G-Z / -S	ESG 4	ESG 5	HDG 2	HDG 4	ZSG 4	ZSG mini	DSG 4	Verso	HSG	
100	100	160	22				110			2.999,00	80 890 322	●												
125	125	192	22				130			3.531,00	80 890 338	●												
160	160	256	22				170			4.353,00	80 890 340	●												

Oversigt systembakker

6-fags vendebakke

- ▲ 1 = Glat, Wolfram-Carbide belagt
- ▲ 2 = Grip med trin 3 mm
- ▲ 3 = Grip med trin 8 mm
- ▲ 4 = Grip med trin 18 mm
- ▲ 5 = Grip rund med trin 8 mm
- ▲ 6 = Grip rund
- ▲ $M_{max} = 60 \text{ Nm}$
- ▲ Inkl. fastspændingsbolte

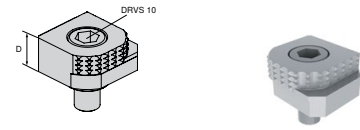

Til skruestikbredde	A	A ₁	D	D ₁	D ₂	E	M	M ₁	M ₂	DKK	Y4	NCG	H5G / -S / -Z	X5G-Z / -S	ESG 4	ESG 5	HGG 2	ZSG 4	ZSG mini	DSG 4	Verso	HSG
			18							603,00	80 892 246	●	●	●	●			●		●	●	

6-fags vendebakke, Carbide grip

- ▲ 1 = Glat
- ▲ 2 = Carbide grip
- ▲ 3 = Carbide grip med trin 3 mm
- ▲ 4 = Carbide grip med trin 8 mm
- ▲ 5 = Carbide grip rund med trin 8 mm
- ▲ 6 = Carbide grip rund
- ▲ Inkl. fastspændingsbolte

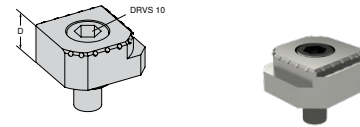

Til skruestikbredde	A	A ₁	D	D ₁	D ₂	E	M	M ₁	M ₂	DKK	Y4	NCG	H5G / -S / -Z	X5G-Z / -S	ESG 4	ESG 5	HGG 2	ZSG 4	ZSG mini	DSG 4	Verso	HSG
			18							875,00	80 890 35300	●	●	●	●			●		●	●	

Oversigt system-tilbehør

Spindelmøtrik

▲ Til ombygning af NCG 5AC til type NCG



		80 890 ...	
Til bredde mm		DKK Y4	
100		1.391,00	385
125		1.474,00	387
160		1.676,00	389

Holdegreb

▲ For nem og sikker transport

Leveringsomfang:

1 stk. holdegreb inkl. fastspændingsbolte

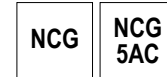

		80 890 ...	
Til bredde mm		DKK Y4	
100/125		136,00	685

Trykstang forlængelse

▲ Til tilslutning af 2 NCG-skruestikker

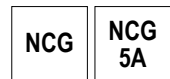

		80 890 ...	
Til bredde mm	B mm	DKK Y4	
100	305 - 460	2.379,00	460
125	390 - 602	2.611,00	470

Beskyttelsesplade

▲ Til bevægelige standard- og kombi-vendebakker og kombi-vendebakker-plus

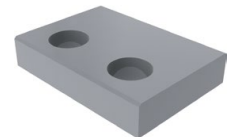
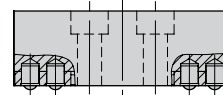

		80 890 ...	
Til bredde mm		DKK Y4	
100		34,00	010
125		26,00	012
160		262,00	013

Afskærmning-sæt

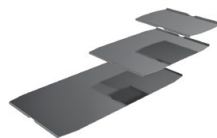
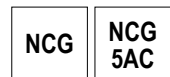

		80 890 ...	
Til bredde mm		DKK Y4	
100		203,00	442
125		232,00	443
160		242,00	444

Fjedrende trykstykke til beskyttelsesplade



		80 890 ...	
Til bredde mm		DKK Y4	
100/125		17,00	008
160		17,00	014

Oversigt system-tilbehør

Spændearm

▲ Inkl. betjeningsstilbehør

NCG	NCG 5A
H5G	



Til bredde mm		DRVS mm	80 890 ...
100/125/160		14	DKK Y4 957,00 501

Hurtigbetjening

▲ Til hurtig spændevidejustering
med aftageligt rundt greb

NCG	NCG 5AC
-----	------------



Til bredde mm		80 890 ...
100		DKK Y4 473,00 550
125/160		562,00 551

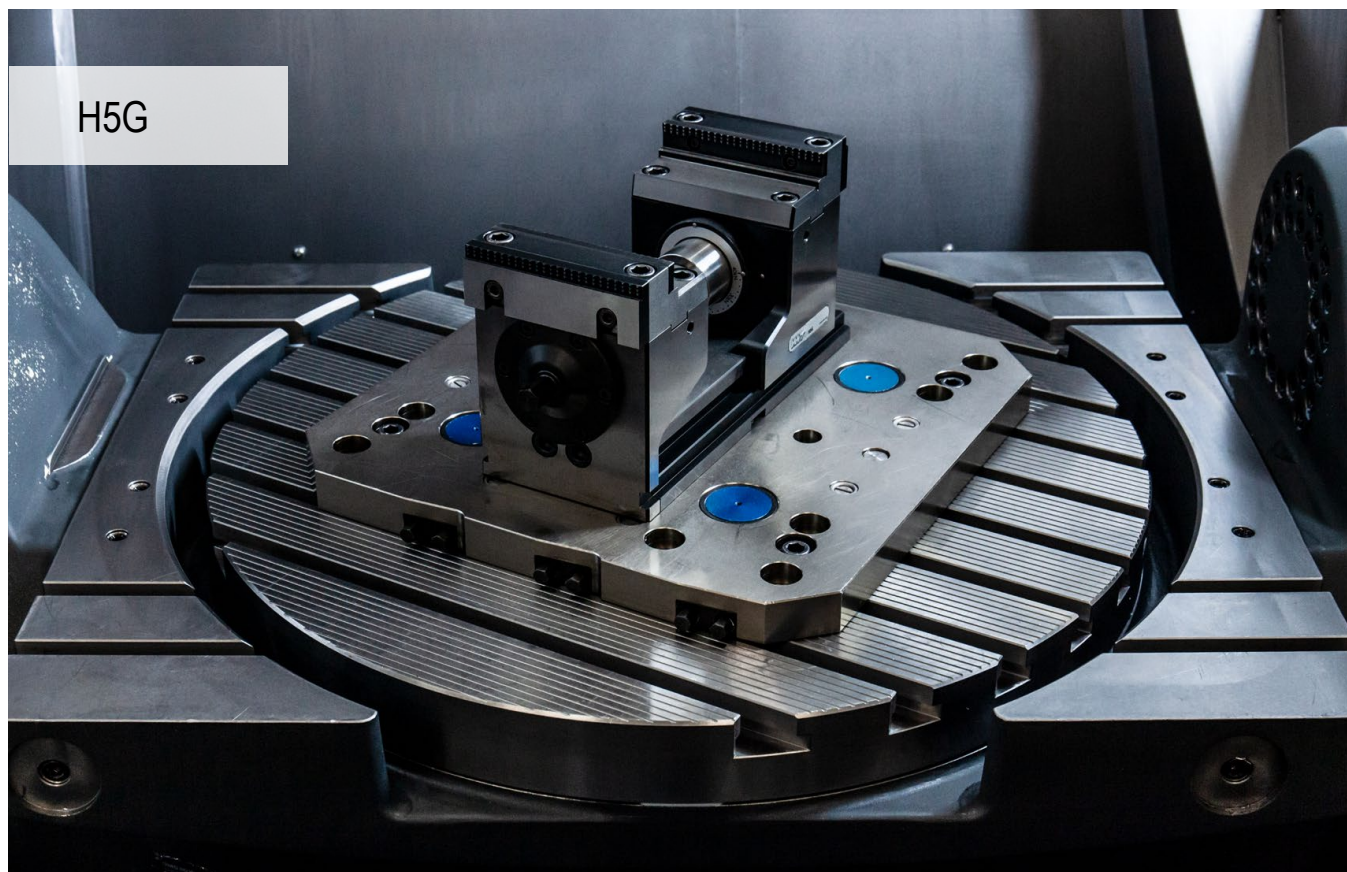

H5G

Spændesystem optimeret til 5 akset

Det forstærkede spændesystem til "ægte" 5-akset komplet- og simultanbearbejdning. 1- og 2-sidet bearbejdning med spændtryk 40 kN direkte på emnet.

Dine fordele:

- ▲ Hurtig konvertering – justering af hele opspændingsområdet på få sekunder
- ▲ Hurtig positionering med MNG på maskinbordet uden mellemlade
- ▲ Spændkraft kan indstilles trinløs 4-40 kN
- ▲ 160° hurtigspænding
- ▲ Drejning af bakker – hurtigt og nemt bakkeskift med 4 skruer
- ▲ Nem rengøring, komplet beskyttet spindel
- ▲ Omfattende modulopbygget bakke-program



Opspænding/justering:

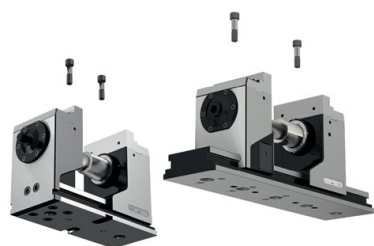

Opspænding med to passkruer Ø 12,7 / M12



Justering via præcisions T-not møtrikker 20^{H7} i grundkroppen (H5G) og justeringssæt 14/16/18 i maskinbordets T-not. Opspænding med spændejern.



Justering og opspænding med nulpunktspændesystem MNG (2-3 antræksbolte). **Valgfri:** Positionerings- og fastgørelshuller efter ønske.

Justerung af forlænger-basisenheden:

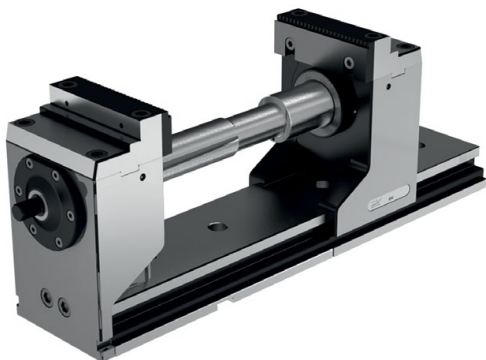

- ▲ Løs montering af forlænger-grundkrop
- ▲ Afstand til grundkrop 0,2-10 mm
- ▲ Skub bevægelig støttebakke overlappende på begge grundkroppe
- ▲ Justér forlænger-grundkrop parallelt med eksisterende grundkrop
- ▲ Fastgør forlænger-grundkrop

Montering af Trykstang forlænger:

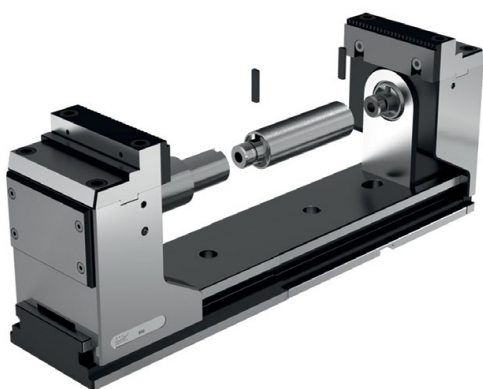

- ▲ Montér grundkroppens forlænger (justering, se ovenfor)
- ▲ Skru Trykstang forlænger på spindlen
- ▲ Indsæt den første drejesikring
- ▲ Skub bevægelig støttebakke på forlænger-grundkroppen
- ▲ Forbind forlænget trykstang med fast støttebakke
- ▲ Indsæt den anden drejesikring

Funktionsprincip for mobil fastbakke:

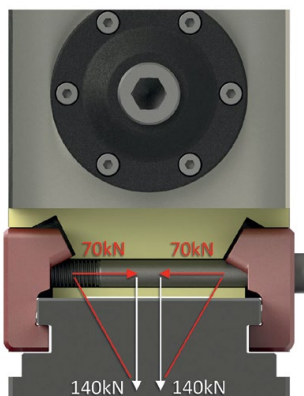

Dobbeltvirkende skrue = Dobbelt kraft
Skrå flader = Dobbelt kraft

Ved H5G-Z og H5G-Z-S kan begge støttebakker forskydes vilkårligt. Den mobile fastbakke kan ved hjælp af 1/2 skruer (1 = H5G-Z / 2 = H5G-Z-S) klemmes fast i enhver vilkårlig position på grundkroppen (fastspænd skrue med 90 Nm). Den faste bakkes holdekraft er næsten identisk med holdekraften ved H5G, som fastgøres med fire skruer.

SoloClamp – H5G

- ▲ 5-akset kraftskruestik med hurtig indstilling, 174 mm høj
- ▲ Håndsving-hurtigspænding
- ▲ Opspænding med spændtryk
- ▲ 100% indkapslet
- ▲ Skruestik udført med længde- og tværnoter 20 H7 og pashuller Ø 12 F7

Leveringsomfang:

Skruestik inkl. 4 spændejern, håndsving og spændenøgle

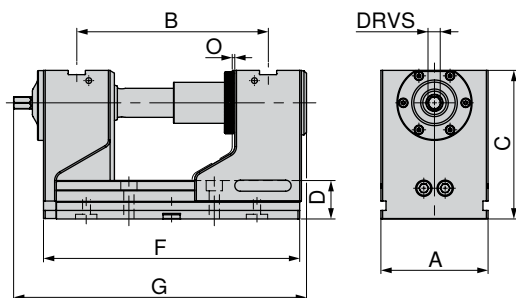
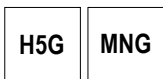

A	B	C	D	F	G	O	DRVS	MXC	WT
mm	mm	mm	mm	mm	mm	mm	mm	kN	kg
125	97 - 223	174	45	300	336,5	1	14	40	30,2

80 898 ...

DKK
Y4
23.786,00 125

SoloClamp – H5G

- ▲ 5-akset kraftskruestik, lang, 174 mm høj

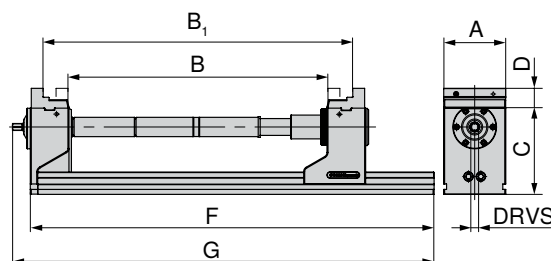
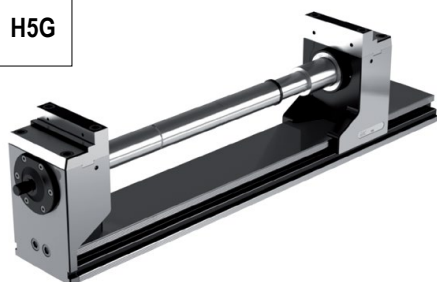

A	C	D	F	G	DRVS	spændkraft
mm	mm	mm	mm	mm	mm	kN
125	174	40	815	851	14	40

B	B ₁	Artikelnummer
0 – 126	123 – 251	80 898 125
125 – 252	248 – 374	80 898 125 + 80 898 826 + 80 898 725
250 – 376	372 – 499	80 898 125 + 80 898 827 + 80 898 725
375 – 501	498 – 624	80 898 125 + 80 898 826 + 80 898 827 + 80 898 725
500 – 626	622 – 749	80 898 125 + 2 x 80 898 827 + 80 898 725



H5G 125 mm kan maksimalt udvides med 2 forlængere på hver 250 mm. For hver forlængelse resulteres i ca. 10 % tab af spændkraft. Lang grundplade med ønsket hulmønster fås kun på forespørgsel.

Skruestikguide

Dimensioner	27	Dimensionstabeller til de forskellige bakker	28–32
Systemtilbehør	33–36	MNG-/PNG-nulpunkt-spændesystem	134–163
Alment tilbehør	164–183		

SoloClamp – H5G-S

- ▲ 5-akset kraftskruestik med hurtig indstilling, 125 mm høj
- ▲ Håndsving-hurtigspænding
- ▲ Opspænding med indstilleligt spændetryk
- ▲ 100% indkapslet
- ▲ Længde F = 300 mm med centrering Ø 25 H7
- ▲ Længde F = 265 mm med centrering Ø 32 H6
- ▲ Grundkrop udført med længde- og tværnoter 20 H7 og huller Ø 12 F7

Leveringsomfang:

Grundkrop inkl. 4 spændejern, håndsving og spændenøgle dog

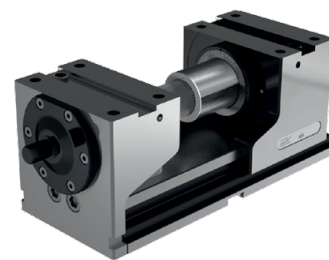
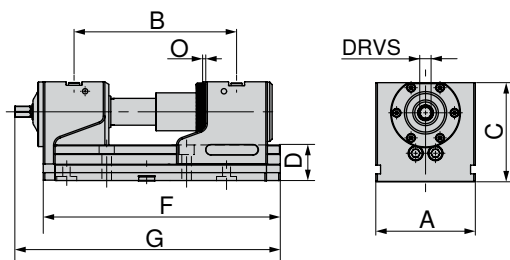

A	B	C	D	F	G	O	DRVS	MXC	WT	80 898 ...	
mm	mm	mm	mm	mm	mm	mm	mm	kN	kg	DKK	
125	97 - 186	125	45	265	301,5	1	14	40	21,0	21.767,00	123 ¹⁾
125	97 - 223	125	45	300	336,5	1	14	40	22,6	22.290,00	124

1) Kan ikke anvendes med MNG

SoloClamp – H5G-S

- ▲ 5-akset skruestik, lang, 125 mm høj

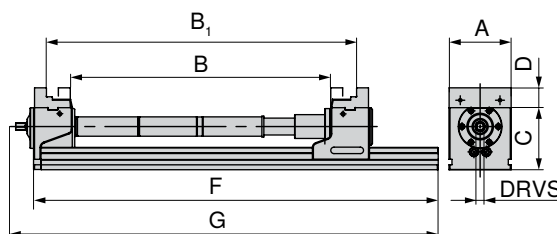

A	C	D	F	G	DRVS	spændkraft
mm	mm	mm	mm	mm	mm	kN
125	125	40	815	851	14	40

B	B ₁	Artikelnummer
0 – 126	123 – 250	80 898 124
125 – 251	248 – 374	80 898 124 + 80 898 826 + 80 898 725
250 – 376	372 – 499	80 898 124 + 80 898 827 + 80 898 725
375 – 501	498 – 624	80 898 124 + 80 898 826 + 80 898 827 + 80 898 725
500 – 626	622 – 749	80 898 124 + 2 x 80 898 827 + 80 898 725



H5G-S 125 mm kan maksimalt udvides med 2 forlængere på hver 250 mm. For hver forlængelse resulteres i ca. 10 % tab af spændkraft. Lang grundplade med ønsket hulmønster fås på forespørgsel.

Skruestikguide

Dimensioner	27	Dimensionstabeller til de forskellige bakker	28–32
Systemtilbehør	33–36	MNG-/PNG-nulpunkt-spændesystem	134–163
Alment tilbehør	164–183		

SoloClamp – H5G-Z

- ▲ 5-akset kraftskruestik med mobil fastbakke, 174 mm høj
- ▲ Håndsving-hurtigspænding
- ▲ Opspænding med indstilleligt spændtryk
- ▲ 100% indkapslet
- ▲ Opspænding på maskinbordet er muligt med MNG/PNG, eller direkte gennem grundkroppen

Leveringsomfang:

Inkl. spændenøgle med sekskantstiftindsats

H5G
-Z

MNG

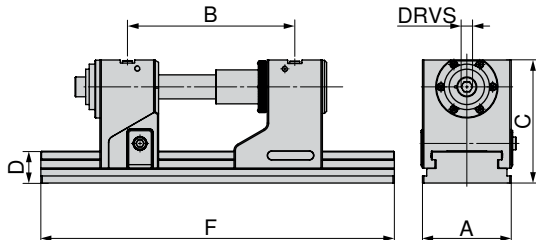

A	B $\pm 0,015$	C	D	F	DRVS	MXC	WT
mm	mm	mm	mm	mm	mm	kN	kg
125	131 - 246	174	45	330	14	40	32,5
125	131 - 352	174	45	430	14	40	36,0
125	131 - 422	174	45	500	14	40	38,5
125	131 - 552	174	45	630	14	40	43,0

80 907 ...

DKK
Y4

26.853,00 12800

27.302,00 125

28.499,00 126

30.892,00 127



→ Side 36

Her finder du ekstra trykstang forlængere, der skal bruges for at nå de maksimale spændeområder.

SoloClamp – H5G-Z-S

- ▲ 5-akset kraftskruestik med mobil fastbakke, 125 mm høj
- ▲ Håndsving-hurtigopspænding
- ▲ Opspænding med indstilleligt spændtryk
- ▲ 100% indkapslet
- ▲ Opspænding på maskinbordet er muligt med MNG/PNG, eller direkte gennem grundkroppen

Leveringsomfang:

Inkl. spændenøgle med sekskantstiftindsats

H5G
-Z-S

MNG

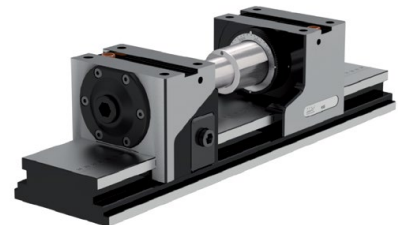
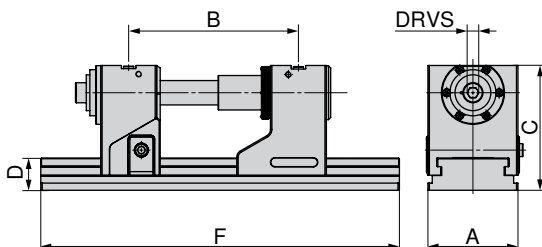

A	B $\pm 0,015$	C	D	F	DRVS	MXC	WT
mm	mm	mm	mm	mm	mm	kN	kg
125	131 - 246	125	45	330	14	40	24,5
125	131 - 352	125	45	430	14	40	28,5
125	131 - 422	125	45	500	14	40	30,5
125	131 - 552	125	45	630	14	40	35,5

80 907 ...

DKK
Y4

25.282,00 22500

25.656,00 22600

27.003,00 22700

29.396,00 22800

H5G/H5G-Z dimensioner

Grundkrop bredde 125 mm
og længde 265 mm

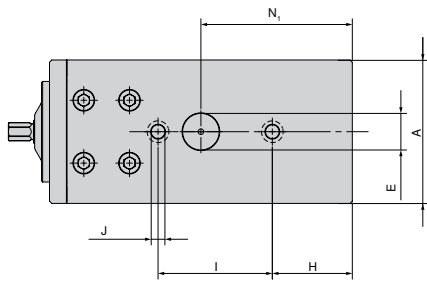

A	E _{H6}	H	I _{±0,015}	J _{F7}	N ₁
mm	mm	mm	mm	mm	mm
125	32	70	100	12	132,5

Grundkrop bredde 125 mm
og længde 430 mm

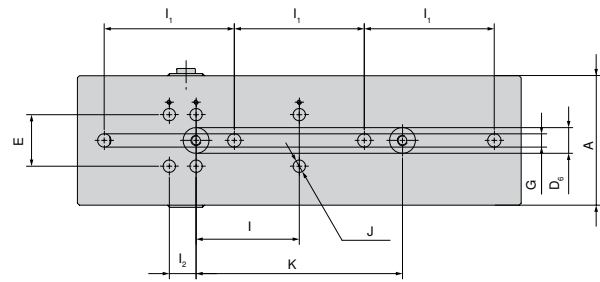

A	E _{±0,01}	I _{1 ±0,3}	I ₂	I _{±0,015}	K _{±0,015}	J _{H7}	G	D _{6 H6}
mm	mm	mm	mm	mm	mm	mm	mm	mm
125	50	126	26	100	200	12	13	25

1 H5G med 265 mm længde er ikke kompatibel med MNG.

Grundkrop bredde 125 mm
og længde 300 mm

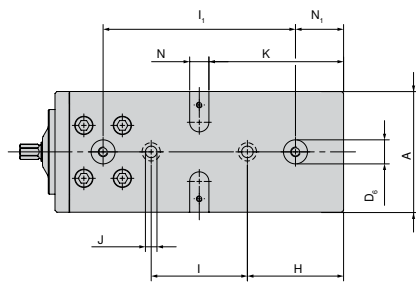

A	D _{6 H7}	H	I _{±0,015}	J _{F7}	K	N _{H7}	I _{1 ±0,015}	N ₁
mm	mm	mm	mm	mm	mm	mm	mm	mm
125	25	100	100	12	140	20	200	50

Grundkrop bredde 125 mm
og længde 500 mm

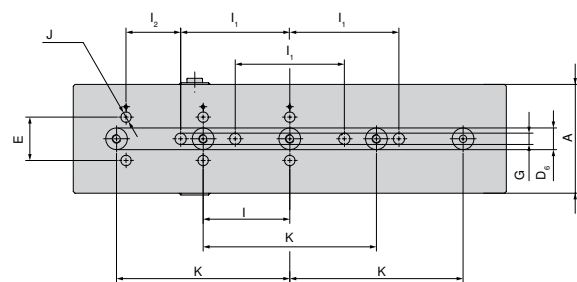

A	E _{±0,01}	I _{1 ±0,3}	I _{±0,015}	K _{±0,015}	I ₂	G	D _{6 H6}	J _{H7}
mm	mm	mm	mm	mm	mm	mm	mm	mm
125	50	126	100	200	63	13	25	12

Grundkrop bredde 125 mm
og længde 330 mm

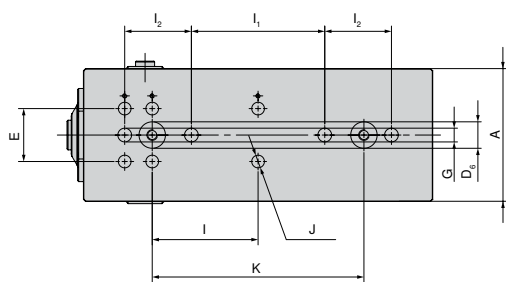

A	E _{±0,01}	I _{±0,015}	I ₂	I _{1 ±0,3}	D _{6 H6}	J _{H7}	K _{±0,015}	G
mm	mm	mm	mm	mm	mm	mm	mm	mm
125	50	100	26	126	25	12	200	13

Grundkrop bredde 125 mm
og længde 630 mm

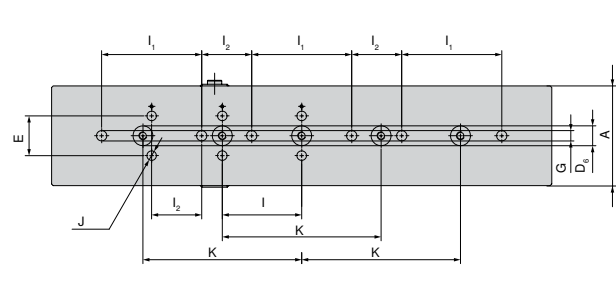

A	E _{±0,01}	I _{1 ±0,3}	I ₂	I _{±0,015}	K _{±0,015}	G	D _{6 H6}	J _{H7}
mm	mm	mm	mm	mm	mm	mm	mm	mm
125	50	126	63	100	200	13	25	12

H5G/H5G-S dimensionstabel til de forskellige bakker

Med kombibakker

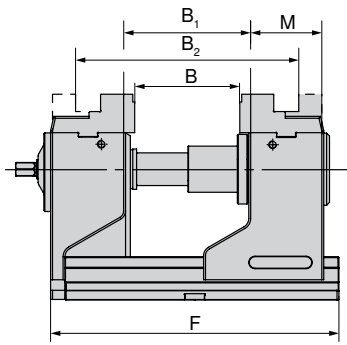

F	B	B ₁	B ₂	M	Art. nr.
mm	mm	mm	mm	mm	Systembakker
265	0 - 89	22 - 112	123 - 212	76	80 898 225
300	0 - 126	22 - 149	123 - 249	76	80 898 225

H5G

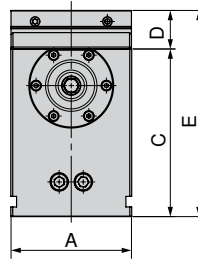

A	C	D	E
mm	mm	mm	mm
-	-	-	-
125	174	40	214

H5G-S

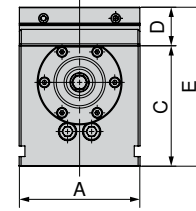

A	C	D	E
mm	mm	mm	mm
125	125	40	165
125	125	40	165

Med 5A-bakker, bakkebredde 65 mm

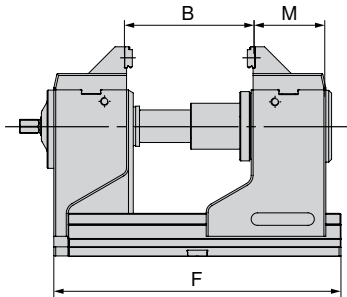

F	B	M	Art. nr.
mm	mm	mm	Systembakker
265	16 - 105	79,5	80 898 325
300	16 - 142	79,5	80 898 325

H5G

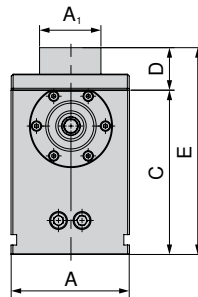

A	A ₁	C	D	E
mm	mm	mm	mm	mm
-	-	-	-	-
125	65	174	45	219

H5G-S

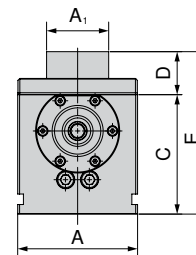

A	A ₁	C	D	E
mm	mm	mm	mm	mm
125	65	125	45	170
125	65	125	45	170

Med 5A-bakker, bakkebredde 125 mm

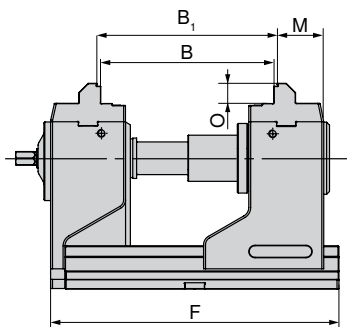

F	B	B ₁	O	M	Art. nr.
mm	mm	mm	mm	mm	Systembakker
265	74 - 162	80 - 168	21	49	80 907 300
300	74 - 199	80 - 205	21	49	80 907 300

H5G

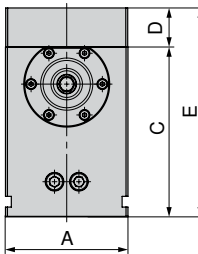

A	C	D	E
mm	mm	mm	mm
-	-	-	-
125	174	40	214

H5G-S

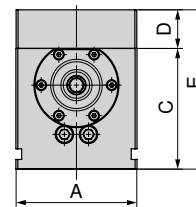

A	C	D	E
mm	mm	mm	mm
125	125	40	165
125	125	40	165

H5G/H5G-S dimensionstabel til de forskellige bakker

Med bløde bakker

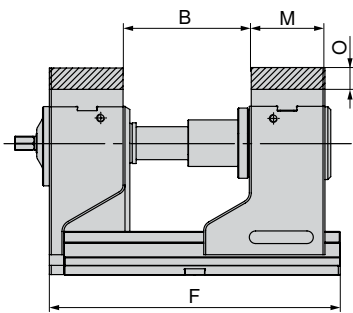

F	B	O	M	Art. nr.
mm	mm	mm	mm	Systembakker
265	23 - 112	22	76	80 898 625
300	23 - 149	22	76	80 898 625

H5G

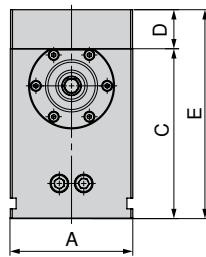

A	C	D	E
mm	mm	mm	mm
-	-	-	-
125	174	40	214

H5G-S

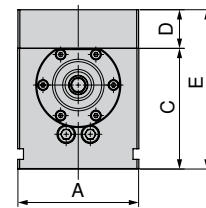

A	C	D	E
mm	mm	mm	mm
125	125	40	165
125	125	40	165

Med vendebakker, grip 3 mm

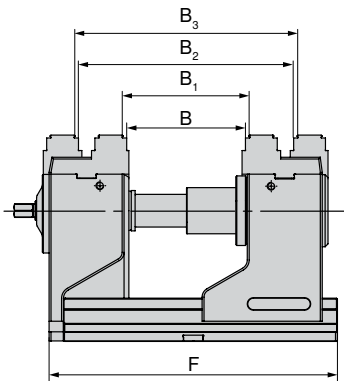

F	B	B ₁	B ₂	B ₃	Art. nr.
mm	mm	mm	mm	mm	Systembakker
265	17 - 106	23 - 112	117 - 206	123 - 212	80 898 35000
300	17 - 140	23 - 146	117 - 240	123 - 246	80 898 35000

H5G

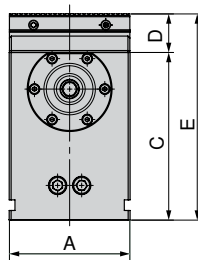

A	C	D	E
mm	mm	mm	mm
-	-	-	-
125	174	40	214

H5G-S

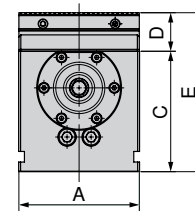

A	C	D	E
mm	mm	mm	mm
125	125	40	165
125	125	40	165

Med pendul- og adapterplade

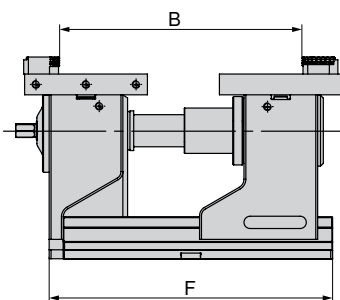

F	B	Art. nr.
mm	mm	Systembakker
265	17 - 236	80 898 525 + 80 898 425
300	17 - 274	80 898 525 + 80 898 425

H5G

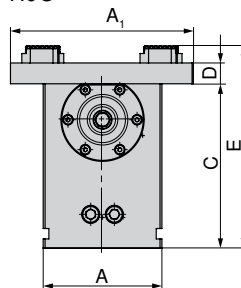

A	A ₁	C	D	E
mm	mm	mm	mm	mm
-	-	-	-	-
125	192	174	22	214

H5G-S

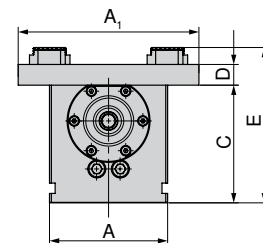

A	A ₁	C	D	E
mm	mm	mm	mm	mm
125	192	125	22	165
125	192	125	22	165

H5G/H5G-S dimensionstabel til de forskellige bakker

Med 6-fags bakkesystem

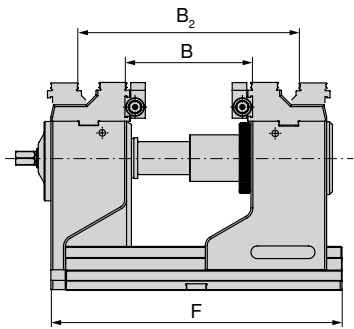

F	B	B ₂	O	M	Art. nr.
mm	mm	mm	mm	mm	Systembakker
265	39-115	119-191	22	76	80 898 230
300	39-152	119-228	22	76	80 898 230

H5G

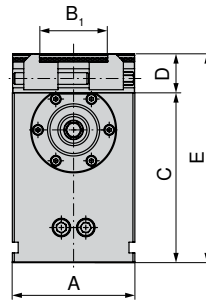

A	B ₁	C	D	E
mm	mm	mm	mm	mm
-	-	-	-	-
125	37-101	174	40	214

H5G-S

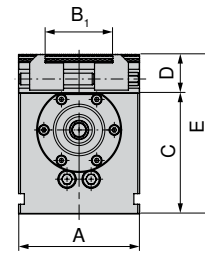

A	B ₁	C	D	E
mm	mm	mm	mm	mm
125	37-101	125	40	165
125	37-101	125	40	165

H5G-Z/-S dimensionstabel til de forskellige bakker

Med kombibakker

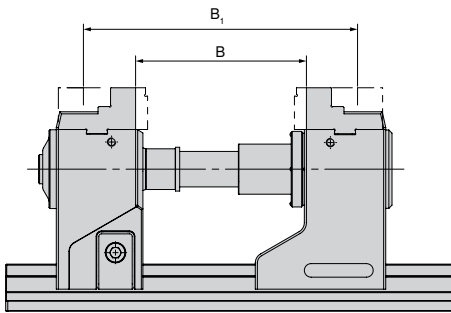

Varianter	B	B ₁	Art. nr.
	mm	mm	Systembakker
H5G-Z	57-182	157-282	80 898 225
H5G-Z-S	47-172	147-272	80 898 225

H5G-Z

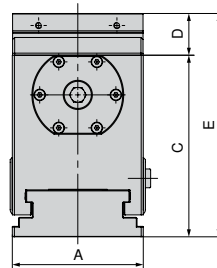

A	C	D	E
mm	mm	mm	mm
125	174	40	214
-	-	-	-

H5G-Z-S

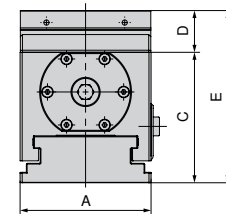

A	C	D	E
mm	mm	mm	mm
-	-	-	-
125	125	40	165

Med 5A-trinbakker

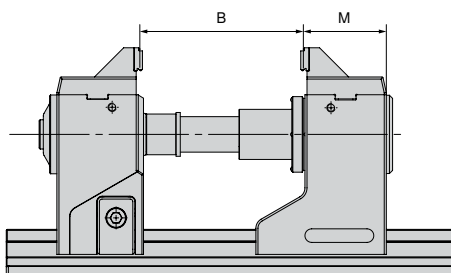

Varianter	B	M	Art. nr.
	mm	mm	Systembakker
H5G-Z	50-175	74	80 898 325
H5G-Z-S	40-165	74	80 898 325

H5G-Z

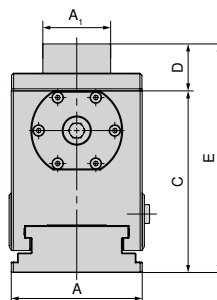

A	A ₁	C	D	E
mm	mm	mm	mm	mm
125	65	174	45	214
-	-	-	-	-

H5G-Z-S

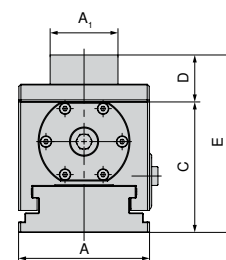

A	A ₁	C	D	E
mm	mm	mm	mm	mm
-	-	-	-	-
125	65	125	45	165

H5G-Z/-S dimensionstabel til de forskellige bakker

Med vendebakke, grip 3 mm og trin, glat 16 mm

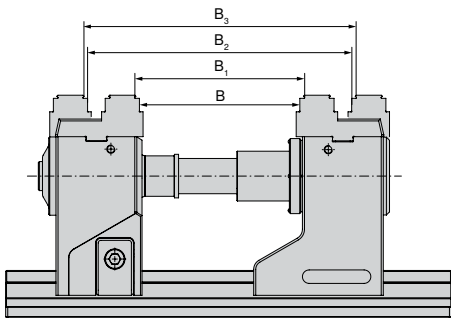

Varianter	B mm	B ₁ mm	B ₂ mm	B ₃ mm	Art. nr. Systembakker
H5G-Z	48-173	54-179	148-273	154-279	2 x 80 898 35000
H5G-Z-S	38-173	44-169	138-263	144-269	2 x 80 898 35000

H5G-Z

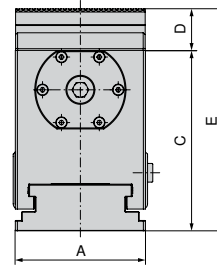

A mm	C mm	D mm	E mm
125	174	40	214
-	-	-	-

H5G-Z-S

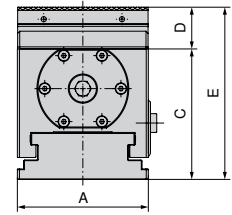

A mm	C mm	D mm	E mm
-	-	-	-
125	125	40	165

Med topbakke 5A, bakkebredde 125 mm

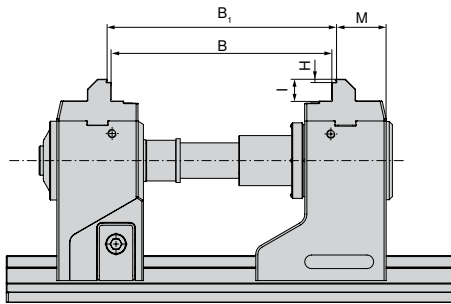

Varianter	B mm	B ₁ mm	H mm	I mm	M mm	Art. nr. Systembakker
H5G-Z	105-230	111-236	3	21	48,7	2 x 80 907 300
H5G-Z-S	95-220	101-226	3	21	48,7	2 x 80 907 300

H5G-Z

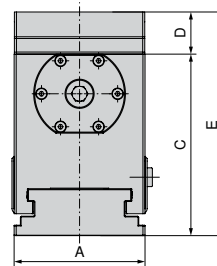

A mm	C mm	D mm	E mm
125	174	40	214
-	-	-	-

H5G-Z-S

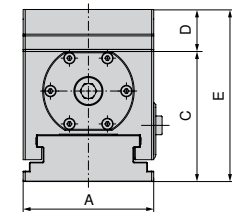

A mm	C mm	D mm	E mm
-	-	-	-
125	125	40	165

Med bløde bakker

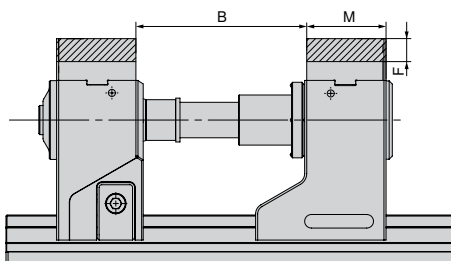

Varianter	B mm	F mm	M mm	Art. nr. Systembakker
H5G-Z	57-182	22	76	80 898 625
H5G-Z-S	47-172	22	76	80 898 625

H5G-Z

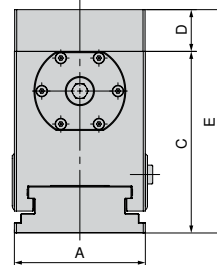

A mm	C mm	D mm	E mm
125	174	40	214
-	-	-	-

H5G-Z-S

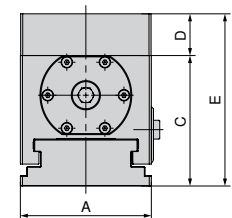

A mm	C mm	D mm	E mm
-	-	-	-
125	125	40	165

H5G-Z/-S dimensionstabel til de forskellige bakker

Med pendul- og adapterplade

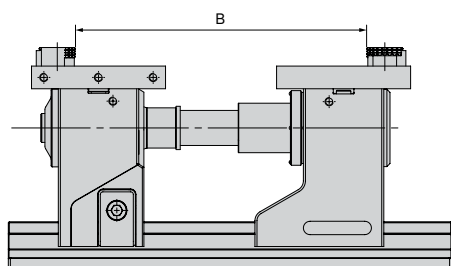

H5G-Z

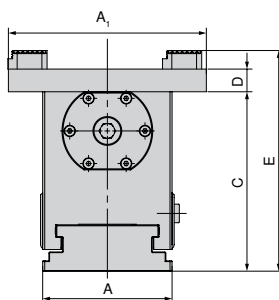

H5G-Z-S

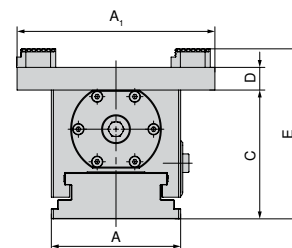

Varianter	B mm	Art. nr. Systembakker
H5G-Z	11 - 300	80 898 525 + 80 898 425
H5G-Z-S	11 - 290	80 898 525 + 80 898 425

A mm	A ₁ mm	C mm	D mm	E mm
125	192	174	40	214
-	-	-	-	-

A mm	A ₁ mm	C mm	D mm	E mm
-	-	-	-	-
125	192	125	40	165

Med 6-fags bakkensystem

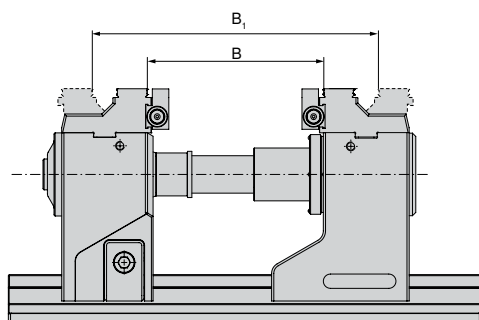

H5G-Z

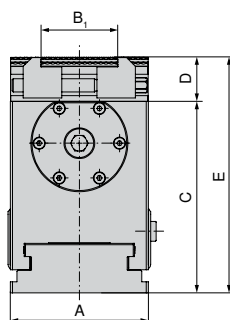

H5G-Z-S

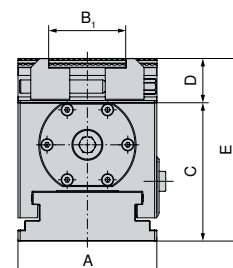

Varianter	B mm	B ₂ mm	Art. nr. Systembakker
H5G-Z	52-177	152-277	80 898 230
H5G-Z-S	42-167	142-267	80 898 230

A mm	B ₁ mm	C mm	D mm	E mm
125	37-101	174	40	214
-	-	-	-	-

A mm	B ₁ mm	C mm	D mm	E mm
-	-	-	-	-
125	37-101	125	40	165



Spændområderne gælder også for grundkroppe 500 mm og 630 mm. Udvidede spændområder er mulige med trykstang forlængelse. De anførte spændområder kan kun delvist opnås med topbakker.

Oversigt systembakker

5A-indsats-trinbakke

- ▲ Inkl. indsats 125/65 mm og 3 mm trinbakke grip
- ▲ Pris pr. stk.

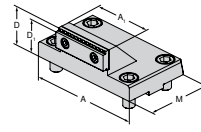

Til skruestikbredde	A	A ₁	D	D ₁	D ₂	E	M	M ₁	M ₂
125	125	65	45	42			76		

DKK

Y4

2.820,00

80 898 325

NCG	H5G / -S / -Z	X5G-Z / -S	ESG 4	ESG 5	HDG 2	ZSG 4	ZSG mini	DSG 4	Verso	HSG
	●									

5A-topbakke

- ▲ Forbedret tilgængelighed via skrånende bagside
- ▲ Pris pr. stk.

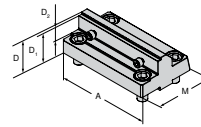

Til skruestikbredde	A	A ₁	D	D ₁	D ₂	E	M	M ₁	M ₂
125	125		40	37	18		78		

DKK

Y4

2.648,00

80 907 300

NCG	H5G / -S / -Z	X5G-Z / -S	ESG 4	ESG 5	HDG 2	ZSG 4	ZSG mini	DSG 4	Verso	HSG
	●									

Kombi-vendebakke

- ▲ Til udvidelse af spændeområdet
- ▲ Pris pr. stk.

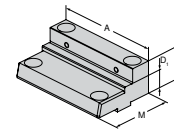

Til skruestikbredde	A	A ₁	D	D ₁	D ₂	E	M	M ₁	M ₂
125	125		40	22			76		

DKK

Y4

2.820,00

80 898 225

NCG	H5G / -S / -Z	X5G-Z / -S	ESG 4	ESG 5	HDG 2	ZSG 4	ZSG mini	DSG 4	Verso	HSG
	●									

Blød alu-bakke

- ▲ Til fremstilling af formbakker
- ▲ Pris pr. stk.

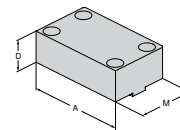

Til skruestikbredde	A	A ₁	D	D ₁	D ₂	E	M	M ₁	M ₂
125	125		40				76		

DKK

Y4

830,00

80 898 625

NCG	H5G / -S / -Z	X5G-Z / -S	ESG 4	ESG 5	HDG 2	ZSG 4	ZSG mini	DSG 4	Verso	HSG
	●									

Oversigt systembakker

Vendebakke, grip 3 mm, trin glat 16 mm, begge sider

▲ Pris pr. stk.

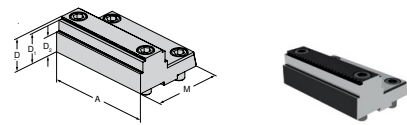

Til skruestikbredde	A	A ₁	D	D ₁	D ₂	E	M	M ₁	M ₂
125	125		40	37	24		82,5		

DKK

Y4

2.985,00

80 898 35000

NCG	H5G / -S / -Z	X5G-Z / -S	ESG 4	ESG 5	HDG 2	ZSG 4	ZSG mini	DSG 4	Verso	HSG
	●									

Pendulbakke, bevægelig

▲ Til montering af 6-fags vendebakker

▲ Pris pr. stk.

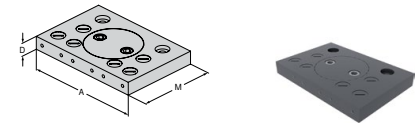

Til skruestikbredde	A	A ₁	D	D ₁	D ₂	E	M	M ₁	M ₂
125	192		22				130		

DKK

Y4

3.673,00

80 898 525

NCG	H5G / -S / -Z	X5G-Z / -S	ESG 4	ESG 5	HDG 2	ZSG 4	ZSG mini	DSG 4	Verso	HSG
	●									

Adapterbakke, fast

▲ Rummer 6 gange vendbare bakker

▲ Pris pr. stk.

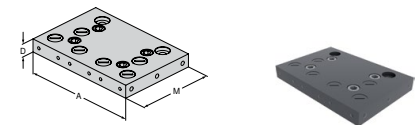

Til skruestikbredde	A	A ₁	D	D ₁	D ₂	E	M	M ₁	M ₂
125	192		22				130		

DKK

Y4

3.097,00

80 898 425

NCG	H5G / -S / -Z	X5G-Z / -S	ESG 4	ESG 5	HDG 2	ZSG 4	ZSG mini	DSG 4	Verso	HSG
	●									

6-fags vendebakke

▲ 1 = Glat, Wolfram-Carbide belagt

▲ 2 = Grip med trin 3 mm

▲ 3 = Grip med trin 8 mm

▲ 4 = Grip med trin 18 mm

▲ 5 = Grip rund med trin 8 mm

▲ 6 = Grip rund

▲ M_{max} = 60 Nm

▲ Inkl. fastspændingsbolte

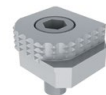
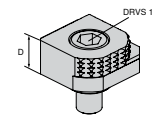

Til skruestikbredde	A	A ₁	D	D ₁	D ₂	E	M	M ₁	M ₂
			18						

DKK

Y4

603,00



80 892 246

NCG	H5G / -S / -Z	X5G-Z / -S	ESG 4	ESG 5	HDG 2	ZSG 4	ZSG mini	DSG 4	Verso	HSG
●	●	●	●			●		●	●	

Oversigt system-tilbehør

Trykstang forlængelse

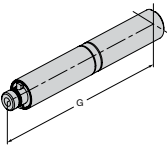
▲ Inkl. anti-twistsikring

H5G	H5G -S			80 898 ...
H5G -Z				
G mm				DKK Y4
125				2.693,00 826
250				3.052,00 827

Blindprop

▲ Pris pr. stk.

H5G -Z		80 907 ...
D₁ mm		DKK Y4
19		9,00 501

Grundplade forlænger

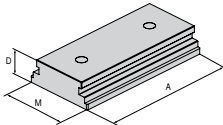
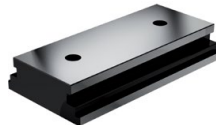

H5G			80 898 ...
A mm	D mm	M mm	DKK Y4
250	45	125,5	4.817,00 725

Spændearm

▲ Inkl. betjenings-tilbehør

NCG	NCG 5A		80 890 ...
H5G			
DRVS mm		DKK Y4	
14		957,00 501	

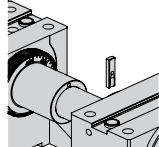
Anti-twist sikring

H5G	H5G -S			80 898 ...
H5G -Z	H5G -Z-S			
				DKK Y4
				93,00 024

Spændearm med led

▲ Uden top

H5G -Z	H5G -Z-S		80 891 ...
ESG 4	ESG mini		
ZSG 4			DKK Y4
			569,00 600
Firkant			
1/2"			

Håndsving

▲ Til hurtigjustering

	H5G-Z X5G-Z	H5G-S H5G-Z-S	H5G
	80 907 ...	80 898 ...	80 898 ...
DRVS mm	DKK Y4	DKK Y4	DKK Y4
14	606,00 500	606,00 026	606,00 025

Unbraco top

▲ Passer til firkant 1/2" eller 3/8"

H5G -Z	ESG mini		80 877 ...
MSG 2	Verso		
MNG			DKK Y4
			136,00 214
Firkant	DRVS mm		
1/2"	14		

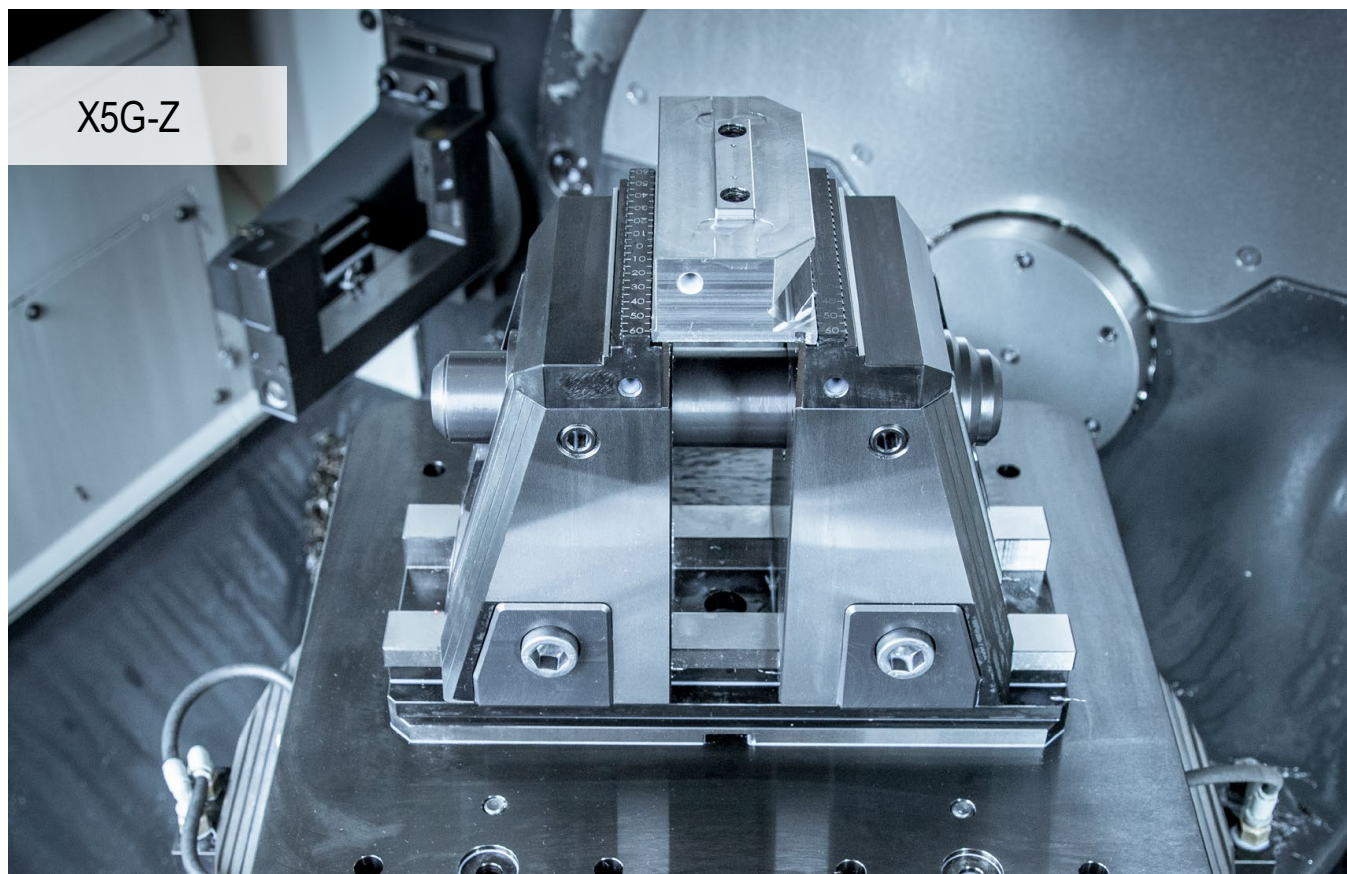

X5G-Z

5-akset bearbejdning til perfektion

Nem håndtering og integreret nedtræk til 6-sidet bearbejdning. X5G-Z er den nye 5-akset-skruestik fra CERATIZIT. Alle fordele ved en optimal og enkel 5- eller 6-sidet bearbejdning samlet i en opspændingsenhed.

Dine fordele:

- ▲ Valgfri 5- eller 6-sidet bearbejdning gennem fastspænding af a en eller begge støttebakker
- ▲ Hurtigskift-bakker uden brug af værktøj
- ▲ Optimal tilgængelighed fra alle sider med et stort basis spændeslag på 130 mm
- ▲ Fuldt indkapslet mekanisk spindel
- ▲ Integreret, indvendig elastomerdæmpning til minimering af vibrationer
- ▲ Omfattende modulopbygget bakke-program



Opspænding/justering:



Opspænding med to passkruer Ø 12,7 / M12 og opspændingsbolte



Justering via præcisions T-not møtrikker 20^{H7} i grundkroppen i maskinbordets T-not. Opspænding med spændejern.



Justering og opspænding med nulpunkt-spændesystem MNG (2-3 antræksbolte). **Valgfri:** Positionerings- og fastgørelseshuller efter ønske.

Spændkraft:

Størrelse		Maks. tilspændingsmoment i Nm	Maks. spændkraft i kN
X5G-Z	Råspænding	100	50
X5G-Z	Præcisionsspænding	120	40
X5G-Z-S	Råspænding	100	50
X5G-Z-S	Præcisionsspænding	120	34

Tilspændingsmoment / spændkraft X5G-Z

Råspænding

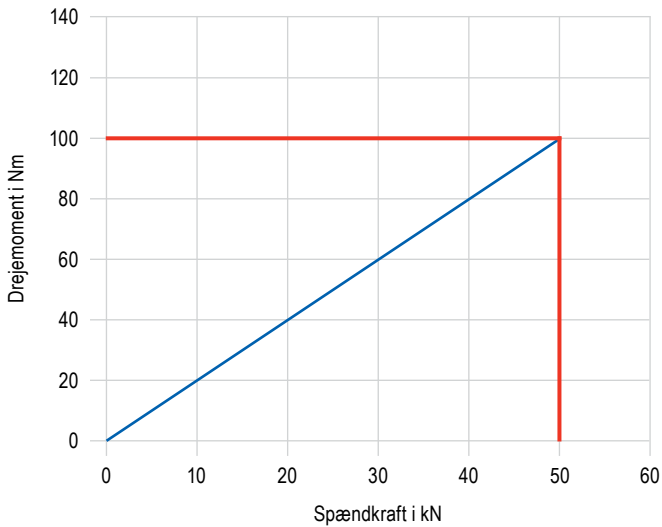

Præcisionsspænding

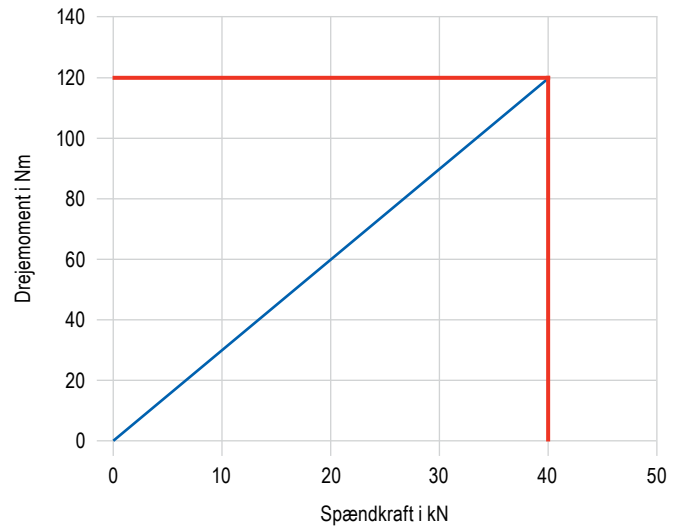

Tilspændingsmoment / spændkraft X5G-Z-S

Råspænding

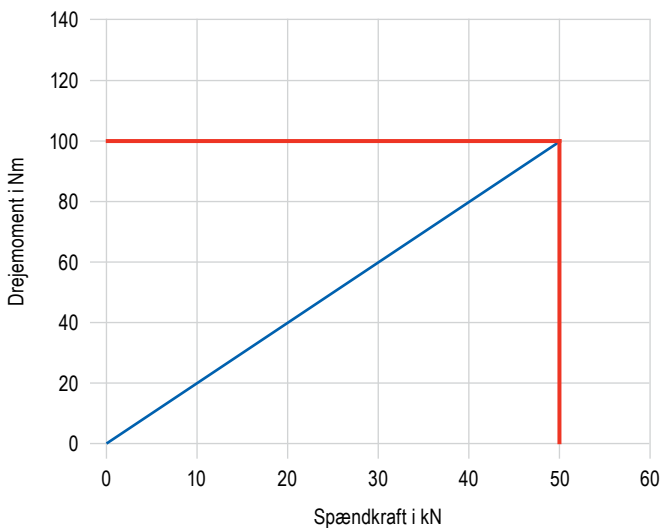

Præcisionsspænding

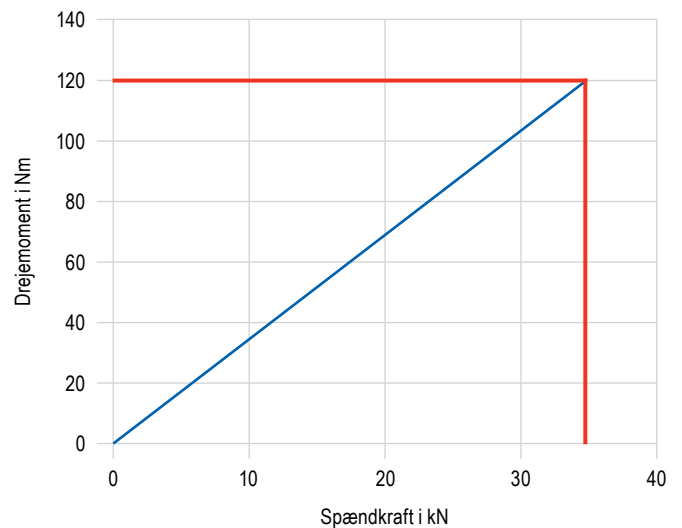

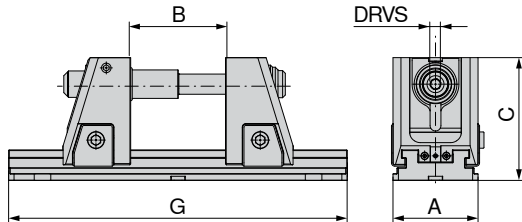
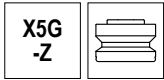

SoloClamp – X5G-Z

- ▲ Mekanisk 5-akset skruestik med mobile fastbakker, højde 181 mm
- ▲ Uden systembakker
- ▲ Bedste tilgængelighed
- ▲ 5- og 6-sidet bearbejdning mulig
- ▲ Hurtigskift-bakker
- ▲ Opspænding på maskinbordet muligt med MNG/PNG, eller direkte gennem grundkroppen



A	B	C	G	DRVS	MXC	WT	80 908 ...	
mm	mm	mm	mm	mm	kN	kg	DKK	
							Y4	
125	4 - 134	181	330	14	40	33,2	23.712,00	52500
125	4 - 234	181	430	14	40	36,1	25.432,00	52600
125	4 - 304	181	500	14	40	38,1	26.479,00	52700
125	4 - 434	181	630	14	40	41,8	28.424,00	52800
125	4 - 604	181	800	14	40	46,6	30.967,00	52900

 Basis spændeslag 130 mm

 → **Side 48**
Her finder du ekstra trykstang forlængere, der skal bruges for at nå de maksimale spændeområder.

 → **Side 42-44**
Her finder du dimensionerne på de forskellige kæber.

Skruestikguide

Dimensioner	41	Systemtilbehør	45
MNG-/PNG-nulpunkt-spændesystem	134-163	Alment tilbehør	164-183

SoloClamp – X5G-Z-S

- ▲ Mekanisk 5-akset skruestik med mobile fastbakker, højde 142 mm
- ▲ Uden systembakker
- ▲ Bedste tilgængelighed
- ▲ 5- og 6-sidet bearbejdning mulig
- ▲ Hurtigskift-bakker
- ▲ Opspænding på maskinbordet muligt med MNG/PNG, eller direkte gennem grundkroppen

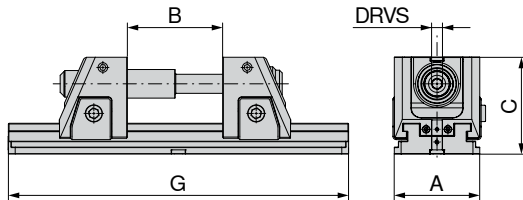
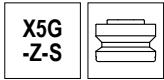

A	B	C	G	DRVS	MXC	WT	80 908 ...	
mm	mm	mm	mm	mm	kN	kg	DKK	
125	4 - 134	142	330	14	40	27,3	21.542,00	42500
125	4 - 234	142	430	14	40	30,2	23.263,00	42600
125	4 - 304	142	500	14	40	32,2	24.310,00	42700
125	4 - 434	142	630	14	40	35,9	26.255,00	42800
125	4 - 604	142	800	14	40	40,7	28.873,00	42900

 Basis spændeslag 130 mm

 → **Side 48**
Her finder du ekstra trykstang forlængere, der skal bruges for at nå de maksimale spændeområder.

 → **Side 42-44**
Her finder du dimensionerne på de forskellige kæber.

Skruestikguide

Dimensioner	41	Systemtilbehør	45
MNG-/PNG-nulpunkt-spændesystem	134-163	Alment tilbehør	164-183

X5G-Z/-S dimensioner

Grundkrop bredde 125 mm
og længde 330 mm

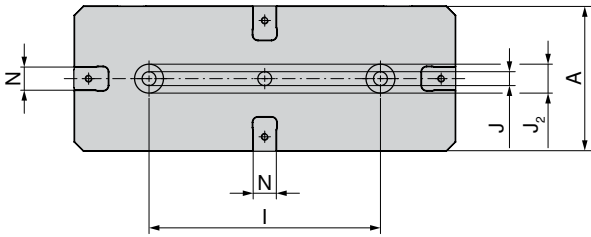

A	I ±0,02	J H7	J ₂ H6	N H7
mm	mm	mm	mm	mm
125	200	12	25	20

Grundkrop bredde 125 mm
og længde 630 mm

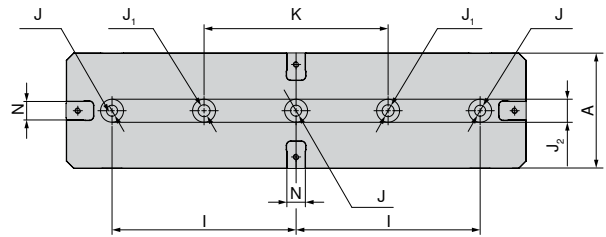

A	I ±0,02	J H7	J ₁	J ₂ H6	K ±0,02	N H7
mm	mm	mm	mm	mm	mm	mm
125	200	12	13	25	200	20

Grundkrop bredde 125 mm
og længde 430 mm

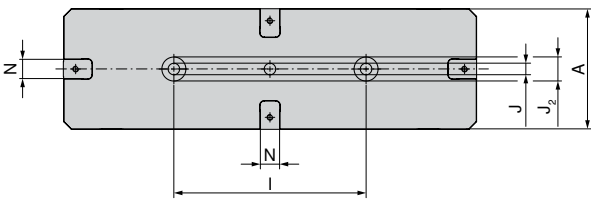

A	I ±0,02	J H7	J ₂ H6	N H7
mm	mm	mm	mm	mm
125	200	12	25	20

Grundkrop bredde 125 mm
og længde 800 mm

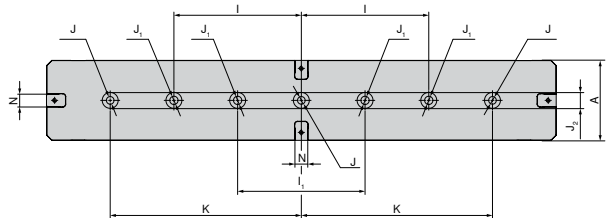

A	I ±0,02	I ₁ ±0,02	J H7	J ₁	J ₂ H6	K ±0,02	N H7
mm	mm	mm	mm	mm	mm	mm	mm
125	200	200	12	13	25	300	20

Grundkrop bredde 125 mm
og længde 500 mm

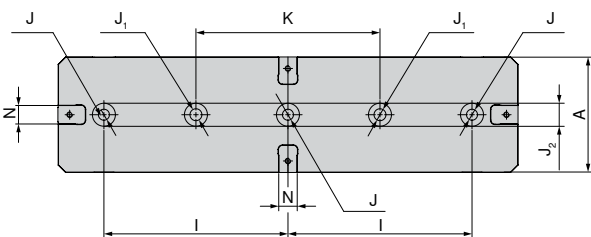

A	I ±0,02	J H7	J ₁	J ₂ H6
mm	mm	mm	mm	mm
125	200	12	13	25

X5G-Z/-S dimensionstabel til de forskellige bakker

Med vendebakker, grip 3 mm

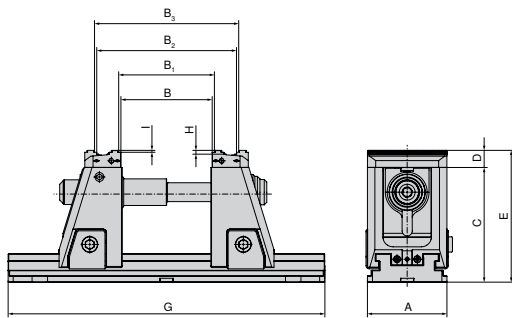

Type	Trykstang forlængelse 430 mm 80 908 80000	Trykstang forlængelse 500 mm 80 908 80100	Trykstang forlængelse 630 mm 80 908 80200	Trykstang forlængelse 800 mm 80 908 80300	A	B	B ₁	B ₂	B ₃	C	D	E	G	H	I
80 908 52500					125	5-134	12-141	80-210	88-217	181	27	208	330	6	3
80 908 42500					125	5-134	12-141	80-210	88-217	142	27	169	330	6	3
80 908 52600	1 x				125	5-234	12-241	80-310	88-317	181	27	208	430	6	3
80 908 42600	1 x				125	5-234	12-241	80-310	88-317	142	27	169	430	6	3
80 908 52700	1 x	1 x			125	5-304	12-311	80-380	88-387	181	27	208	500	6	3
80 908 42700	1 x	1 x			125	5-304	12-311	80-380	88-387	142	27	169	500	6	3
80 908 52800	1 x	1 x	1 x		125	5-434	12-441	80-510	88-517	181	27	208	630	6	3
80 908 42800	1 x	1 x	1 x		125	5-434	12-441	80-510	88-517	142	27	169	630	6	3
80 908 52900	1 x	1 x	1 x	1 x	125	5-604	12-611	80-680	88-687	181	27	208	800	6	3
80 908 42900	1 x	1 x	1 x	1 x	125	5-604	12-611	80-680	88-687	142	27	169	800	6	3

Med vendebakker, grip 5 mm

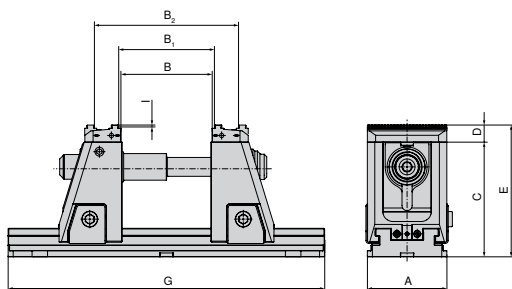

Type	Trykstang forlængelse 430 mm 80 908 80000	Trykstang forlængelse 500 mm 80 908 80100	Trykstang forlængelse 630 mm 80 908 80200	Trykstang forlængelse 800 mm 80 908 80300	A	B	B ₁	B ₂	C	D	E	G	I
80 908 52500					125	5-134	12-141	88-217	181	27	208	330	5
80 908 42500					125	5-134	12-141	88-217	142	27	169	330	5
80 908 52600	1 x				125	5-234	12-241	88-317	181	27	208	430	5
80 908 42600	1 x				125	5-234	12-241	88-317	142	27	169	430	5
80 908 52700	1 x	1 x			125	5-304	12-311	88-387	181	27	208	500	5
80 908 42700	1 x	1 x			125	5-304	12-311	88-387	142	27	169	500	5
80 908 52800	1 x	1 x	1 x		125	5-434	12-441	88-517	181	27	208	630	5
80 908 42800	1 x	1 x	1 x		125	5-434	12-441	88-517	142	27	169	630	5
80 908 52900	1 x	1 x	1 x	1 x	125	5-604	12-611	88-687	181	27	208	800	5
80 908 42900	1 x	1 x	1 x	1 x	125	5-604	12-611	88-687	142	27	169	800	5



→ Side 48

Her finder du passende trykstang forlængere.

X5G-Z/-S dimensionstabel til de forskellige bakker

Med trinbakker, Carbide grip 5 mm

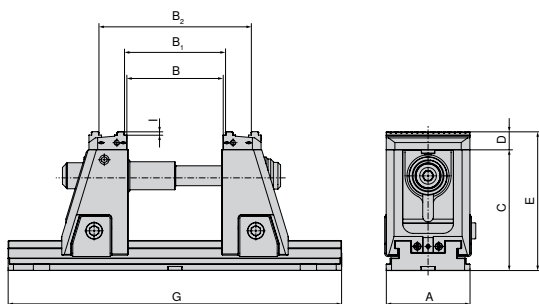

Type	Trykstang forlængelse 430 mm 80 908 80000	Trykstang forlængelse 500 mm 80 908 80100	Trykstang forlængelse 630 mm 80 908 80200	Trykstang forlængelse 800 mm 80 908 80300	A	B	B ₁	B ₂	C	D	E	G	I
80 908 52500					125	5-134	12-141	88-217	181	27	208	330	5
80 908 42500					125	5-134	12-141	88-217	142	27	169	330	5
80 908 52600	1 x				125	5-234	12-241	88-317	181	27	208	430	5
80 908 42600	1 x				125	5-234	12-241	88-317	142	27	169	430	5
80 908 52700	1 x	1 x			125	5-304	12-311	88-387	181	27	208	500	5
80 908 42700	1 x	1 x			125	5-304	12-311	88-387	142	27	169	500	5
80 908 52800	1 x	1 x	1 x		125	5-434	12-441	88-517	181	27	208	630	5
80 908 42800	1 x	1 x	1 x		125	5-434	12-441	88-517	142	27	169	630	5
80 908 52900	1 x	1 x	1 x	1 x	125	5-604	12-611	88-687	181	27	208	800	5
80 908 42900	1 x	1 x	1 x	1 x	125	5-604	12-611	88-687	142	27	169	800	5

Med bløde bakker, stål

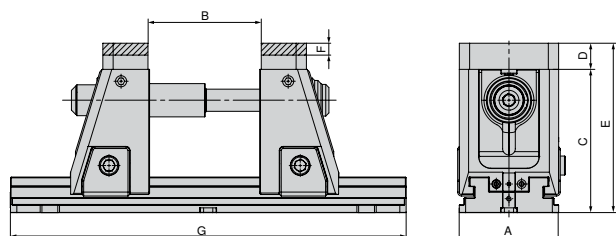
Art. nr.
Systembakker

2 x 80 909 31200

Type	Trykstang forlængelse 430 mm 80 908 80000	Trykstang forlængelse 500 mm 80 908 80100	Trykstang forlængelse 630 mm 80 908 80200	Trykstang forlængelse 800 mm 80 908 80300	A	B	C	D	E	F	G
80 908 52500					125	4-134	181	33	214	15	330
80 908 42500					125	4-134	142	33	175	15	330
80 908 52600	1 x				125	4-234	181	33	214	15	430
80 908 42600	1 x				125	4-234	142	33	175	15	430
80 908 52700	1 x	1 x			125	4-304	181	33	214	15	500
80 908 42700	1 x	1 x			125	4-304	142	33	175	15	500
80 908 52800	1 x	1 x	1 x		125	4-434	181	33	214	15	630
80 908 42800	1 x	1 x	1 x		125	4-434	142	33	175	15	630
80 908 52900	1 x	1 x	1 x	1 x	125	4-604	181	33	214	15	800
80 908 42900	1 x	1 x	1 x	1 x	125	4-604	142	33	175	15	800



→ Side 48

Her finder du passende trykstang forlængere.

X5G-Z/-S dimensionstabel til de forskellige bakker

Med vendebakker prægeprofil

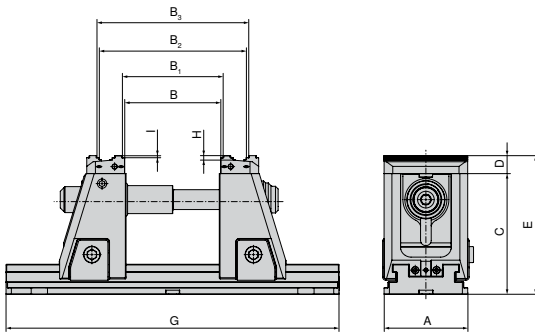
Art. nr.
Systembakker

2 x 80 908 31200

Type	Trykstang forlængelse 430 mm 80 908 80000	Trykstang forlængelse 500 mm 80 908 80100	Trykstang forlængelse 630 mm 80 908 80200	Trykstang forlængelse 800 mm 80 908 80300	A	B	B ₁	B ₂	B ₃	C	D	E	G	H	I
80 908 52500					125	5-134	12-141	82-210	89-217	181	27	208	330	6	3
80 908 42500					125	5-134	12-141	82-210	89-217	142	27	169	330	6	3
80 908 52600	1 x				125	5-234	12-241	82-310	89-317	181	27	208	430	6	3
80 908 42600	1 x				125	5-234	12-241	82-310	89-317	142	27	169	430	6	3
80 908 52700	1 x	1 x			125	5-304	12-311	82-380	89-387	181	27	208	500	6	3
80 908 42700	1 x	1 x			125	5-304	12-311	82-380	89-387	142	27	169	500	6	3
80 908 52800	1 x	1 x	1 x		125	5-434	12-441	82-510	89-517	181	27	208	630	6	3
80 908 42800	1 x	1 x	1 x		125	5-434	12-441	82-510	89-517	142	27	169	630	6	3
80 908 52900	1 x	1 x	1 x	1 x	125	5-604	12-611	82-680	89-687	181	27	208	800	6	3
80 908 42900	1 x	1 x	1 x	1 x	125	5-604	12-611	82-680	89-687	142	27	169	800	6	3

Med pendul- og adapterplade

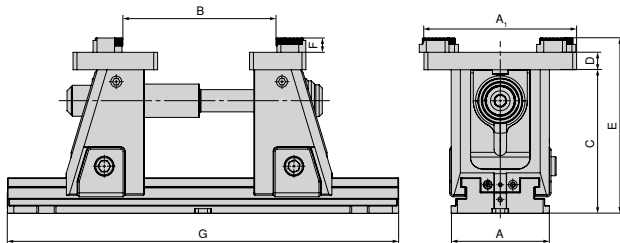
Art. nr.
Systembakker

80 909 31500 + 80 909 31300

Type	Trykstang forlængelse 430 mm 80 908 80000	Trykstang forlængelse 500 mm 80 908 80100	Trykstang forlængelse 630 mm 80 908 80200	Trykstang forlængelse 800 mm 80 908 80300	A	B	C	D	E	F	G
80 908 52500					125	42-210	181	22	221	18	330
80 908 42500					125	42-210	142	22	182	18	330
80 908 52600	1 x				125	42-310	181	22	221	18	430
80 908 42600	1 x				125	42-310	142	22	182	18	430
80 908 52700	1 x	1 x			125	42-380	181	22	221	18	500
80 908 42700	1 x	1 x			125	42-380	142	22	182	18	500
80 908 52800	1 x	1 x	1 x		125	42-510	181	22	221	18	630
80 908 42800	1 x	1 x	1 x		125	42-510	142	22	182	18	630
80 908 52900	1 x	1 x	1 x	1 x	125	42-680	181	22	221	18	800
80 908 42900	1 x	1 x	1 x	1 x	125	42-680	142	22	182	18	800



→ Side 48

Her finder du passende trykstang forlængere.

Oversigt systembakker

Vendebakke, grip 3 mm, bredde 40 mm

▲ Pris pr. stk.

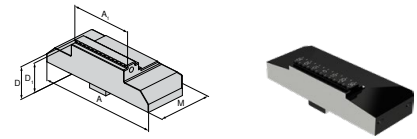

Til skruestikbredde	A	A ₁	D	D ₁	D ₂	E	M	M ₁	M ₂	DKK	Y4	NCG	H5G / -S / -Z	X5G-Z / -S	ESG 4	ESG 5	HDG 2	ZSG 4	ZSG mini	DSG 4	Verso	HSG		
125	125	40	27	24			57			2.259,00	80 908 30300			●										
125	125	65	27	24			57			2.349,00	80 908 30200			●										
125	125	80	27	24			57			2.349,00	80 908 30100			●										
125	125	125	27	24			57			2.424,00	80 908 30000			●										

Vendebakke, grip 5 mm, bredde 40 mm

▲ Pris pr. stk.

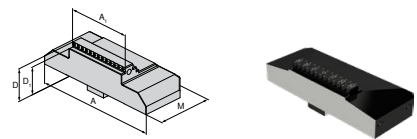

Til skruestikbredde	A	A ₁	D	D ₁	D ₂	E	M	M ₁	M ₂	DKK	Y4	NCG	H5G / -S / -Z	X5G-Z / -S	ESG 4	ESG 5	HDG 2	ZSG 4	ZSG mini	DSG 4	Verso	HSG		
125	125	40	27	22			57			2.259,00	80 908 30700			●										
125	125	65	27	22			57			2.349,00	80 908 30600			●										
125	125	80	27	22			57			2.349,00	80 908 30500			●										
125	125	125	27	22			57			2.424,00	80 908 30400			●										

Vendebakke, glat

▲ Pris pr. stk.

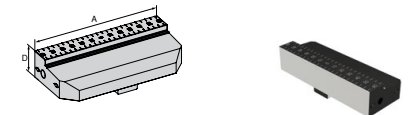

Til skruestikbredde	A	A ₁	D	D ₁	D ₂	E	M	M ₁	M ₂	DKK	Y4	NCG	H5G / -S / -Z	X5G-Z / -S	ESG 4	ESG 5	HDG 2	ZSG 4	ZSG mini	DSG 4	Verso	HSG		
125	125		27							2.424,00	80 908 31400			●										

Trinbakke, HM, grip 5 mm

▲ Pris pr. stk.

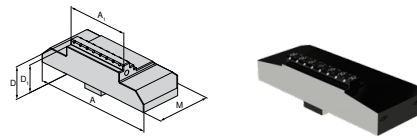

Til skruestikbredde	A	A ₁	D	D ₁	D ₂	E	M	M ₁	M ₂	DKK	Y4	NCG	H5G / -S / -Z	X5G-Z / -S	ESG 4	ESG 5	HDG 2	ZSG 4	ZSG mini	DSG 4	Verso	HSG		
125	125	40	27	22			57			2.678,00	80 908 31100			●										
125	125	65	27	22			57			2.768,00	80 908 31000			●										
125	125	80	27	22			57			2.842,00	80 908 30900			●										
125	125	125	27	22			57			2.932,00	80 908 30800			●										

Oversigt systembakker

Blød bakke

- ▲ Materiale: 16MnCr5
- ▲ Pris pr. stk.

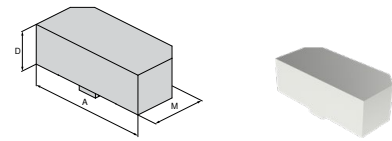

Til skruestikbredde	A	A ₁	D	D ₁	D ₂	E	M	M ₁	M ₂	DKK	Y4	NCG	H5G / -S / -Z	X5G-Z / -S	ESG 4	ESG 5	HDG 2	ZSG 4	ZSG mini	DSG 4	Verso	HSG	
125	125		33				57			1.047,00				●									
											80 909 31200												

Vendebakke prægeprofil

- ▲ Pris pr. stk.
- ▲ Passer til prægeprofil LANG

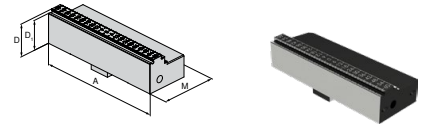

Til skruestikbredde	A	A ₁	D	D ₁	D ₂	E	M	M ₁	M ₂	DKK	Y4	NCG	H5G / -S / -Z	X5G-Z / -S	ESG 4	ESG 5	HDG 2	ZSG 4	ZSG mini	DSG 4	Verso	HSG	
125	125		27	24			57			2.424,00				●									
											80 908 31200												

Adapterbakke

- ▲ Til montering af 6-fags vendebakker
- ▲ Pris pr. stk.
- ▲ Inkl. dækskruer

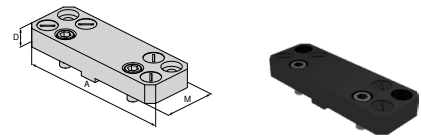

Til skruestikbredde	A	A ₁	D	D ₁	D ₂	E	M	M ₁	M ₂	DKK	Y4	NCG	H5G / -S / -Z	X5G-Z / -S	ESG 4	ESG 5	HDG 2	ZSG 4	ZSG mini	DSG 4	Verso	HSG	
125	180		22				104			3.097,00				●									
											80 909 31500												

Pendulbakke

- ▲ Til montering af 6-fags vendebakker
- ▲ Pris pr. stk.
- ▲ Inkl. dækskruer

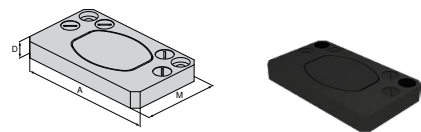

Til skruestikbredde	A	A ₁	D	D ₁	D ₂	E	M	M ₁	M ₂	DKK	Y4	NCG	H5G / -S / -Z	X5G-Z / -S	ESG 4	ESG 5	HDG 2	ZSG 4	ZSG mini	DSG 4	Verso	HSG	
125	180		22				62			4.136,00				●									
											80 909 31300												

Oversigt systembakker

6-fags vendebakke

- ▲ 1 = Glat, Wolfram-Carbide belagt
- ▲ 2 = Grip med trin 3 mm
- ▲ 3 = Grip med trin 8 mm
- ▲ 4 = Grip med trin 18 mm
- ▲ 5 = Grip rund med trin 8 mm
- ▲ 6 = Grip rund
- ▲ $M_{max} = 60 \text{ Nm}$
- ▲ Inkl. fastspændingsbolte

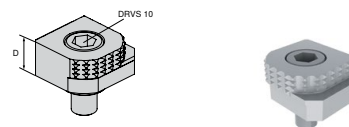

Til skruestikbredde	A	A ₁	D	D ₁	D ₂	E	M	M ₁	M ₂	DKK	Y4	NCG	H5G / -S / -Z	X5G-Z / -S	ESG 4	ESG 5	HDC 2	ZSG 4	ZSG mini	DSG 4	Verso	HSG
			18							603,00	80 892 246	●	●	●	●			●		●	●	●

6-fags vendebakke, Carbide grip

- ▲ 1 = Glat
- ▲ 2 = Carbide grip
- ▲ 3 = Carbide grip med trin 3 mm
- ▲ 4 = Carbide grip med trin 8 mm
- ▲ 5 = Carbide grip rund med trin 8 mm
- ▲ 6 = Carbide grip rund
- ▲ Inkl. fastspændingsbolte

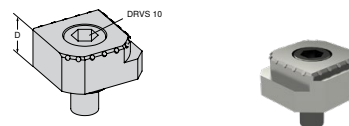

Til skruestikbredde	A	A ₁	D	D ₁	D ₂	E	M	M ₁	M ₂	DKK	Y4	NCG	H5G / -S / -Z	X5G-Z / -S	ESG 4	ESG 5	HDC 2	ZSG 4	ZSG mini	DSG 4	Verso	HSG
			18							875,00	80 890 35300	●	●	●	●			●		●	●	●

Præcisionsbakke

- ▲ Pris pr. sæt

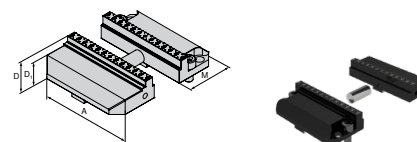

Til skruestikbredde	A	A ₁	D	D ₁	D ₂	E	M	M ₁	M ₂	DKK	Y4	NCG	H5G / -S / -Z	X5G-Z / -S	ESG 4	ESG 5	HDC 2	ZSG 4	ZSG mini	DSG 4	Verso	HSG	
125	125		27	24					57	3.665,00	80 908 31300			●									

Instruktion til hærdet præcisionsbakesæt

X5G-Z imponerer med en ekstrem præcision, alle komponenter er slebet eller hårdfræset med stor præcision. Ikke desto mindre er der anvendelser, hvor den krævede præcision ikke er fuldt ud opnået. I disse tilfælde tilbyder vi et hærdet præcisionsbakesæt (art.nr. **80 908 31300**), som kan hårdfræses af brugeren på spændefladen (begge sider).

Håndbearbejdningen udføres i præcisionsskruestikken (begge skruer på støttebakkerne spændes til 140 Nm). Præcisionsbakkerne skal hårdfræses iht. med de viste standpositioner (1+2). Den medfølgende referencespids bruges til opspænding i standardposition (1). For opspænding i VS-position (2) kan et endemål anvendes.

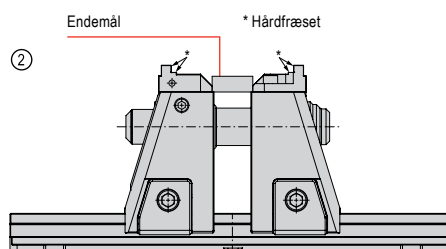
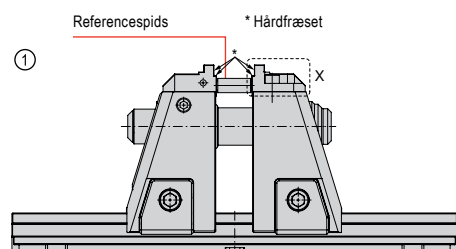

Oversigt system-tilbehør

Spindelenhed X5G-Z

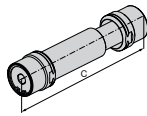

C mm	WT kg
227,5	2,5

80 908 ...
DKK
Y4
2.932,00 50100

Håndsving

- ▲ Designet som sekskant
- ▲ Til hurtigjustering



H5G-Z
X5G-Z
80 907 ...

Til bredde mm	DRVS mm
125	14

DKK
Y4
606,00 500

Trykstang forlængelse

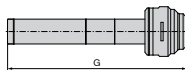

Til bredde mm	G mm
125	430
125	500
125	630
125	800

80 908 ...
DKK
Y4
1.227,00 80000
1.324,00 80100
1.533,00 80200
1.758,00 80300

Unbraco top



Firkant	DRVS mm
1/2"	14

80 877 ...
DKK
Y4
136,00 214

Momentnøgle

- ▲ Uden top



Firkant	TQX Nm
1/2"	10 - 100

80 884 ...
DKK
Y4
2.094,00 502

ESG 4

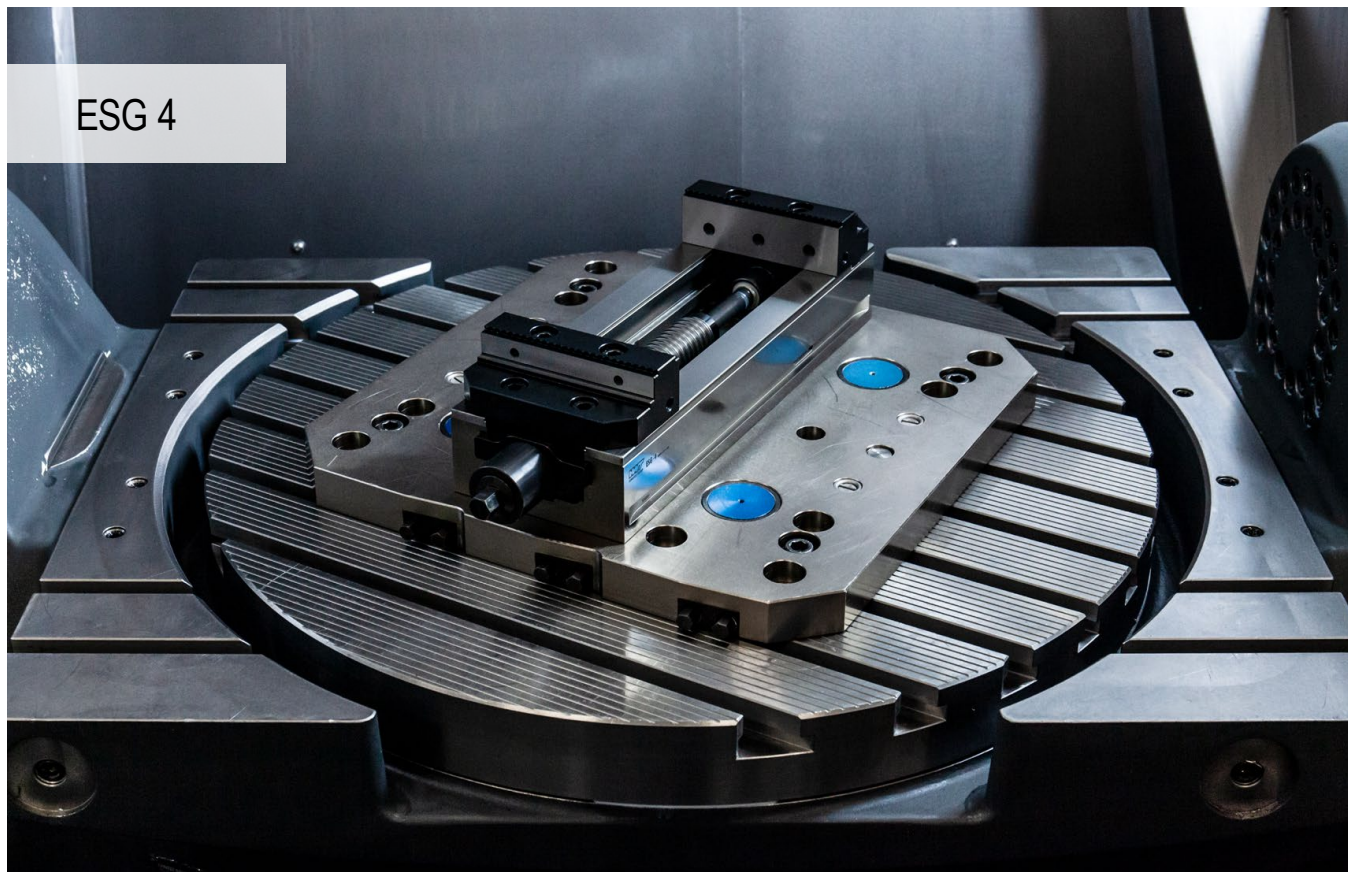

High performance allrounder

Enkel skruestik ESG 4 er overbevisende med hurtig opspænding med håndtag, hurtig justering af spændeområdet, flad konstruktion og lav vægt.

Dine fordele:

- ▲ Flere kølevæskefløb for problemfrit arbejde og kontrolleret afløb
- ▲ Nem og hurtig positionering på MNG-nulpunkt-spændesystem
- ▲ Spændkraft 5-50 kN med lavt tilspændingsmoment
- ▲ Nemt og hurtigt bakkeskift med 2 skruer
- ▲ Hurtig og nem demontering af spindelenheden
- ▲ Omfattende modulopbygget bakke-program

Opspænding/justering:



ESG 4-80 mm = Fastgørelse med M8-skruer gennem grundkroppen
ESG 4 – 125 mm/160 mm = Fastgørelse med M12-skruer og passkrue gennem grundkroppen

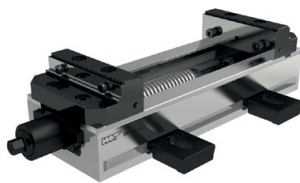

Fastgørelse med 4 spændejern



Fastgørelse med nulpunkt-spændesystem
ESG 4-80 mm = 1 antræksbolt + drejesikring
ESG 4 – 125/160 mm = 2 antræksbolte stikmål 200 mm

Spændkraft:

Tilspændingsmoment / spændkraft ESG 4 – 80 mm

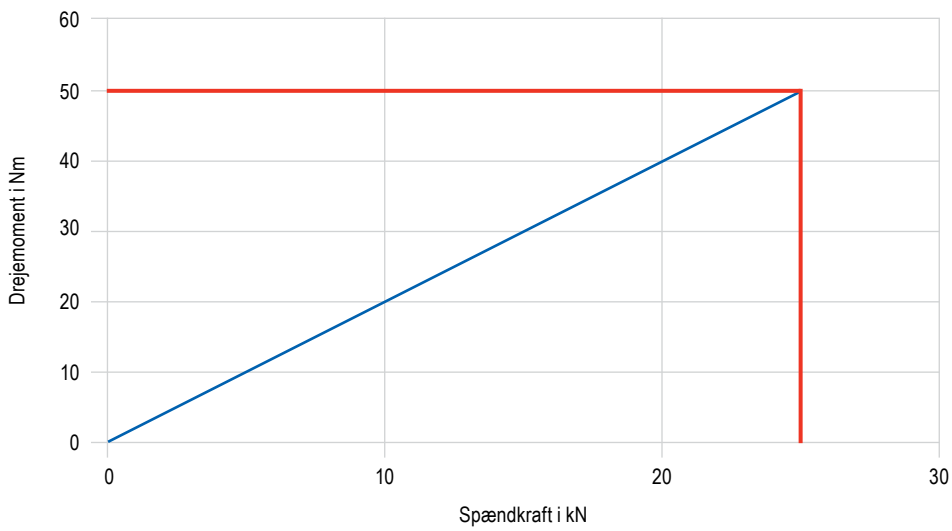

Tilspændingsmoment / spændkraft ESG 4 – 125 mm

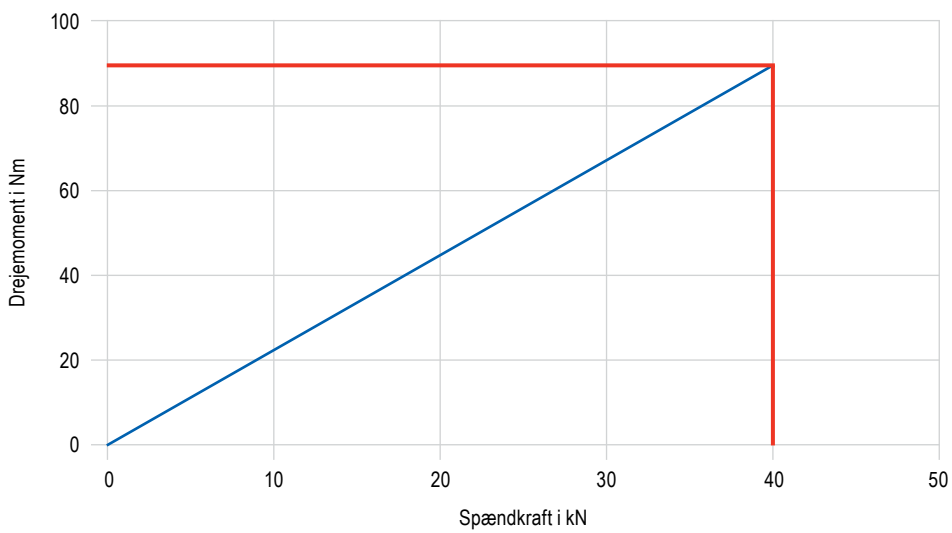

Tilspændingsmoment / spændkraft ESG 4 – 160 mm

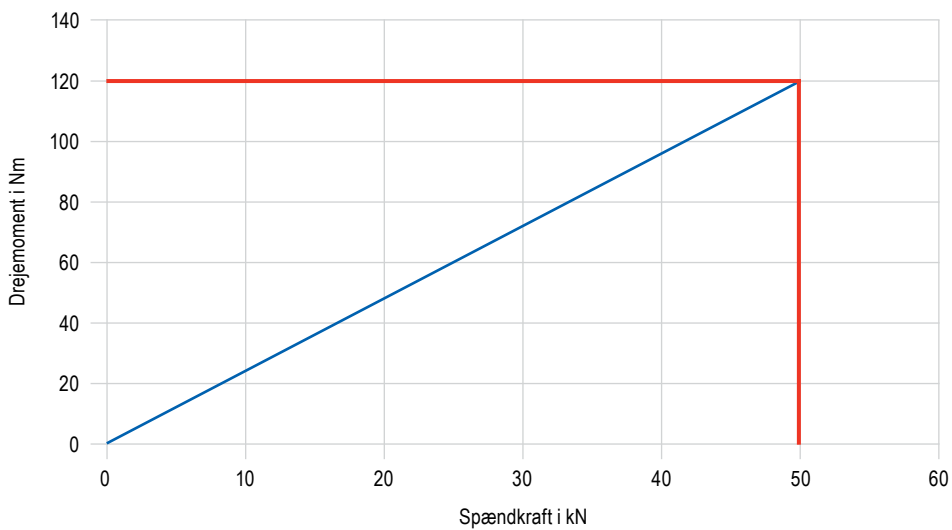

SoloClamp – ESG 4

- ▲ Enkel skruestik uden systembakker
- ▲ Hurtig 160° håndtagsopspænding med drejemomentnøgle
- ▲ Hurtig på- og afmontering af spindelmodulet
- ▲ $\pm 0,01$ mm gentagelsesnøjagtighed ($\pm 0,015$ mm ved A = 160 mm)

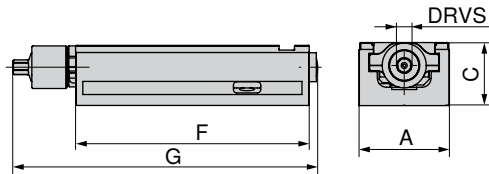
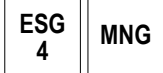

A mm	C _{-0.02} mm	F mm	G mm	DRVS mm	MXC kN	WT kg	Spændeområde mm	80 901 ... DKK Y4
80	55	214	284	12	25	5,0	0-192	9.200,00 080
125	60	362	433	14	40	15,0	0-308	11.370,00 125
160	70	480	559	14	50	28,5	0-434	16.606,00 160

Skruestikguide

Dimensioner	52	Dimensionstabeller til de forskellige bakker	53+54
Systemtilbehør	55–58	MNG-/PNG-nulpunkt-spændesystem	134–163
Alment tilbehør	164–183		

ESG 4 dimensioner

Grundkrop bredde 80 mm
og længde 214 mm

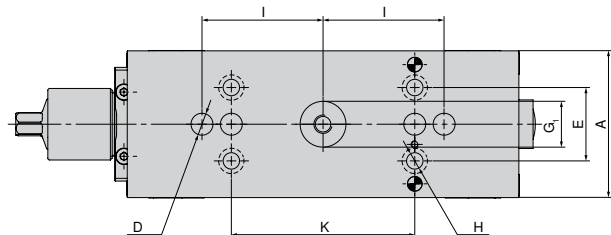

A	D	E	G ₁	H	I	K
mm	mm	mm	mm	mm	mm	mm
80	12	40	25	9	66	100

Grundkrop bredde 125 mm
og længde 362 mm

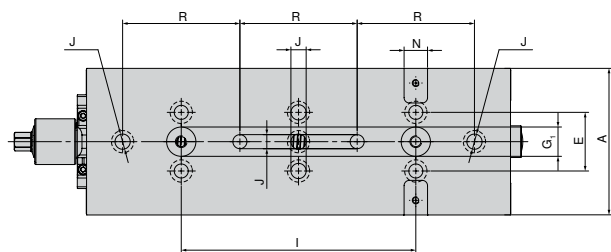

A	E	G ₁	I	J	N _{H7}	R
mm	mm	mm	mm	mm	mm	mm
125	50	25	200	13	20	100

Grundkrop bredde 160 mm
og længde 480 mm

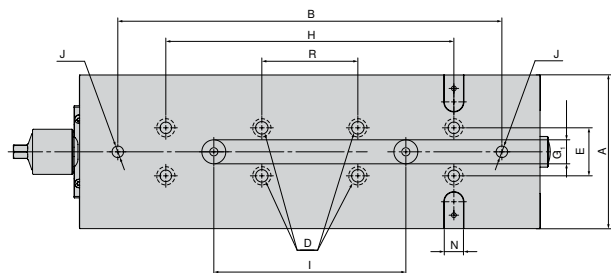

A	B	D	E	G ₁	H	I	J	N _{H7}	R
mm	mm	mm	mm	mm	mm	mm	mm	mm	mm
160	400	13	50	25	300	200	12	20	100

ESG 4 dimensionstabel til de forskellige bakker

Med blokbakker

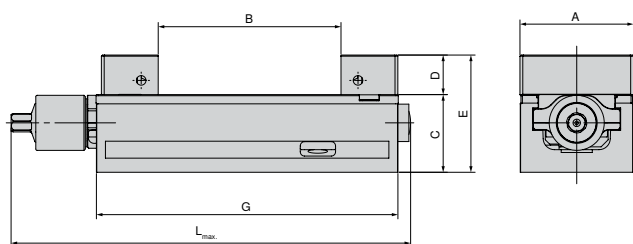

A mm	B mm	C mm	D mm	E mm	G mm	L_max. mm	Art. nr. Systembakker
80	0 - 130	55	28	83	214	308	80 901 31200 + 80 901 31300
125	0 - 231	60	40	100	362	432	80 901 31400 + 80 901 31500
160	0 - 312	70	50	120	480	559	80 901 31600 + 80 901 31700

Med bløde alubakker

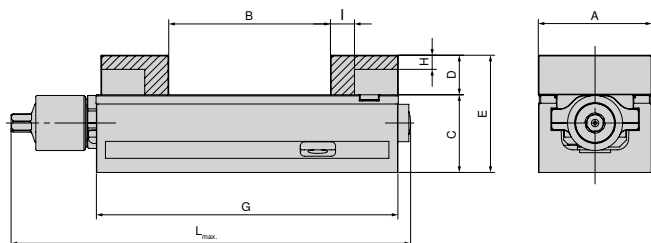

A mm	B mm	C mm	D mm	E mm	G mm	H mm	I mm	L_max. mm	Art. nr. Systembakker
80	0 - 115	55	28	83	214	10	17	284	80 901 307 + 80 878 850
125	0 - 219	60	40	100	362	23	27	432	80 901 304 + 80 878 550
160	0 - 309	70	50	120	480	23	30	559	80 901 301 + 80 878 305

Med pendul- og adapterplade

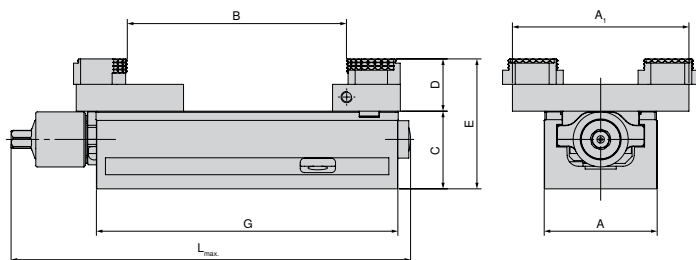

A mm	A1 mm	B mm	C mm	D mm	E mm	G mm	L_max. mm	Art. nr. Systembakker
80	125	5 - 155	55	19	92	214	284	80 878 870 + 80 901 501
125	180	4 - 306	60	22	100	362	432	80 878 570 + 80 901 502
160	256	11 - 463	70	22	110	480	559	80 878 670 + 80 901 503

ESG 4 dimensionstabel til de forskellige bakker

Med vendebakker, grip 3 mm

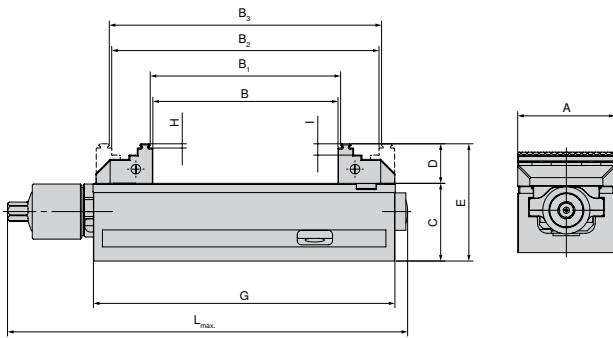

A mm	B mm	B ₁ mm	B ₂ mm	B ₃ mm	C mm	D mm	E mm	G mm	H mm	I mm	L _{max} mm	Art. nr. Systembakker
80	0 - 130	4 - 134	59 - 188	63 - 192	55	28	83	214	3	8	284	80 901 306 + 80 878 810
125	0 - 231	8 - 238	71 - 301	78 - 308	60	40	100	362	3	18	433	80 901 302 + 80 901 303
160	0 - 310	8 - 317	117 - 427	125 - 434	70	50	120	480	3	10	559	80 901 300 + 80 878 610

Med vendebakker, grip 3 mm, bredde 40 mm

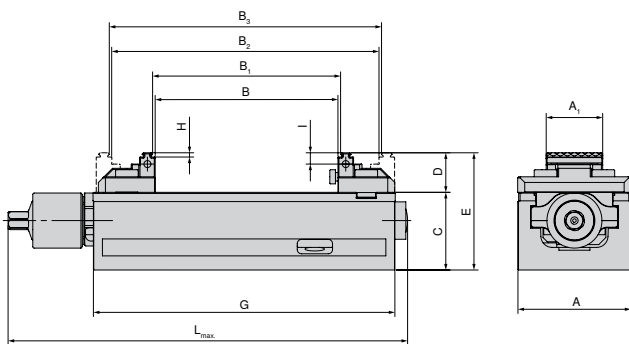

A mm	A ₁ mm	B mm	B ₁ mm	B ₂ mm	B ₃ mm	C mm	D mm	E mm	G mm	H mm	I mm	L _{max} mm	Art. nr. Systembakker
80	40	0 - 130	4 - 134	59 - 188	63 - 192	55	28	83	214	3	8	284	80 901 308 + 80 878 8100

Med vendebakker, grip 3 mm, bredde 65 mm

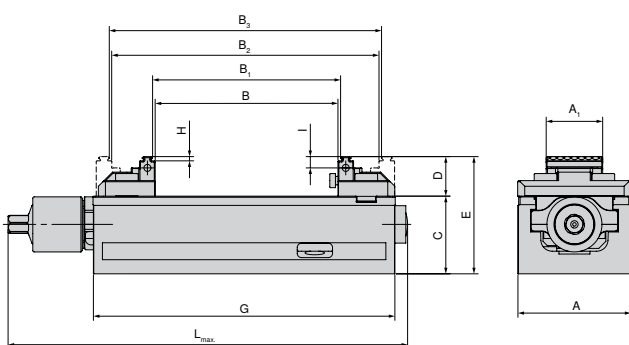

A mm	A ₁ mm	B mm	B ₁ mm	B ₂ mm	B ₃ mm	C mm	D mm	E mm	G mm	H mm	I mm	L _{max} mm	Art. nr. Systembakker
125	65	0 - 240	8 - 247	77 - 317	84 - 324	60	33	93	362	3	9	432	80 901 305 + 80 878 51900

Oversigt systembakker

Vendebakke, grip 3 mm, fast

▲ Pris pr. stk.

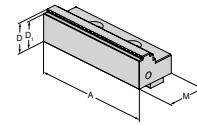

Til skruestikbredde	A	A ₁	D	D ₁	D ₂	E	M	M ₁	M ₂	DKK	Y4	NCG	H5G / -S / -Z	X5G-Z / -S	ESG 4	ESG 5	HDG 2	ZSG 4	ZSG mini	DSG 4	Verso	HSG	
80	80		28	25			40			1.219,00	80 901 306				●	●							
125	125		40	37			66			1.676,00	80 901 302				●	●					●		
160	160		50	47			81			3.022,00	80 901 300				●	●							

Vendebakke, grip 3 mm, bevægelig

▲ Pris pr. stk.

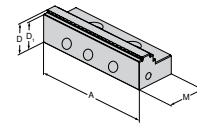

Til skruestikbredde	A	A ₁	D	D ₁	D ₂	E	M	M ₁	M ₂	DKK	Y4	NCG	H5G / -S / -Z	X5G-Z / -S	ESG 4	ESG 5	HDG 2	ZSG 4	ZSG mini	DSG 4	Verso	HSG	
80	80		28	25			40			1.010,00	80 878 810				●	●					●		
125	125		40	37			66			1.676,00	80 901 303				●	●					●		
160	160		50	47			81			3.022,00	80 878 610				●	●							

Blokbakke, fast

▲ Pris pr. stk.

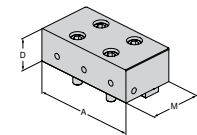

Til skruestikbredde	A	A ₁	D	D ₁	D ₂	E	M	M ₁	M ₂	DKK	Y4	NCG	H5G / -S / -Z	X5G-Z / -S	ESG 4	ESG 5	HDG 2	ZSG 4	ZSG mini	DSG 4	Verso	HSG	
80	80		28				40			1.877,00	80 901 31200				●	●							
125	125		40				66			2.611,00	80 901 31400				●	●							
160	160		50				81			3.299,00	80 901 31600				●	●							

Blokbakke, bevægelig

▲ Pris pr. stk.

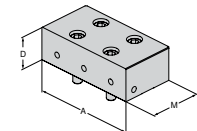

Til skruestikbredde	A	A ₁	D	D ₁	D ₂	E	M	M ₁	M ₂	DKK	Y4	NCG	H5G / -S / -Z	X5G-Z / -S	ESG 4	ESG 5	HDG 2	ZSG 4	ZSG mini	DSG 4	Verso	HSG	
80	80		28				40			1.825,00	80 901 31300				●	●					●		
125	125		40				66			2.558,00	80 901 31500				●	●					●		
160	160		50				81			3.216,00	80 901 31700				●	●							

Oversigt systembakker

Alubakke, fast

- ▲ Til fremstilling af formbakker
- ▲ Pris pr. stk.

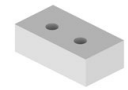
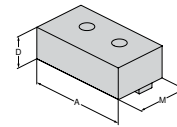

Til skruestikbredde	A	A ₁	D	D ₁	D ₂	E	M	M ₁	M ₂	DKK	Y4	NCG	H5G / -S / -Z	X5G-Z / -S	ESG 4	ESG 5	HDC 2	ZSG 4	ZSG mini	DSG 4	Verso	HSG		
80	80		28				48			755,00	80 901 307				●	●								
125	125		40				68			823,00	80 901 304				●	●								
160	160		50				85			928,00	80 901 301				●	●								

Alubakke

- ▲ Til fremstilling af formbakker
- ▲ Pris pr. stk.

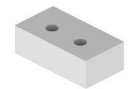
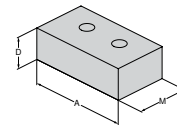

Til skruestikbredde	A	A ₁	D	D ₁	D ₂	E	M	M ₁	M ₂	DKK	Y4	NCG	H5G / -S / -Z	X5G-Z / -S	ESG 4	ESG 5	HDC 2	ZSG 4	ZSG mini	DSG 4	Verso	HSG		
80	80		28				48			646,00	80 878 850				●	●		●		●				
125	125		40				68			735,00	80 878 550				●	●				●				
160	160		50				85			928,00	80 878 305				●	●		●						

Blød bakke, stål, fast

- ▲ Materiale: 16MnCr5
- ▲ Til fremstilling af formbakker
- ▲ Pris pr. stk.

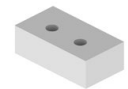
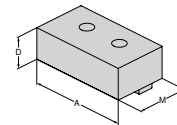

Til skruestikbredde	A	A ₁	D	D ₁	D ₂	E	M	M ₁	M ₂	DKK	Y4	NCG	H5G / -S / -Z	X5G-Z / -S	ESG 4	ESG 5	HDC 2	ZSG 4	ZSG mini	DSG 4	Verso	HSG		
80	80		28				48			778,00	80 901 31800				●	●								
125	125		40				68			935,00	80 901 31900				●	●								

Blød bakke, stål, bevægelig

- ▲ Materiale: 16MnCr5
- ▲ Til fremstilling af formbakker
- ▲ Pris pr. stk.

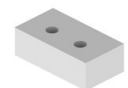
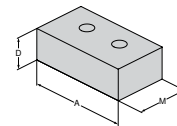

Til skruestikbredde	A	A ₁	D	D ₁	D ₂	E	M	M ₁	M ₂	DKK	Y4	NCG	H5G / -S / -Z	X5G-Z / -S	ESG 4	ESG 5	HDC 2	ZSG 4	ZSG mini	DSG 4	Verso	HSG		
80	80		28				48			666,00	80 878 32000				●	●		●						
125	125		40				68			838,00	80 878 32100				●	●		●						

Oversigt systembakker

Vendebakke, grip, bredde 40 mm, fast

- ▲ Pris pr. stk.
- ▲ Dobbelt-sided griptrin

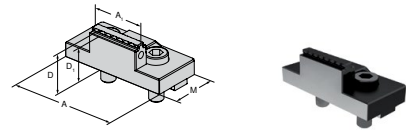

Til skruestikbredde	A	A ₁	D	D ₁	D ₂	E	M	M ₁	M ₂
80	80	40	28	25			40		

DKK
1.466,00

Y4	NCG	H5G / -S / -Z	X5G-Z / -S	ESG 4	ESG 5	HDG 2	ZSG 4	ZSG mini	DSG 4	Verso	HSG
80 901 308				●							

Vendebakke, grip 3 mm, bredde 40 mm, bevægelig

- ▲ Pris pr. stk.

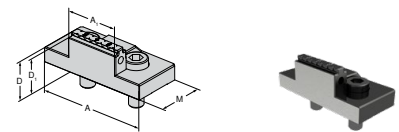

Til skruestikbredde	A	A ₁	D	D ₁	D ₂	E	M	M ₁	M ₂
80	80	40	28	25			40		

DKK
1.346,00

Y4	NCG	H5G / -S / -Z	X5G-Z / -S	ESG 4	ESG 5	HDG 2	ZSG 4	ZSG mini	DSG 4	Verso	HSG
80 878 81900				●			●				

5-akset vendebakke, grip, bredde 65 mm, fast

- ▲ Pris pr. stk.
- ▲ Dobbelt-sided griptrin

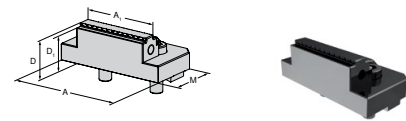

Til skruestikbredde	A	A ₁	D	D ₁	D ₂	E	M	M ₁	M ₂
125	95	65	33	30			57		

DKK
1.601,00

Y4	NCG	H5G / -S / -Z	X5G-Z / -S	ESG 4	ESG 5	HDG 2	ZSG 4	ZSG mini	DSG 4	Verso	HSG
80 901 305				●							

5-akset vendebakke, grip 3 mm, bredde 65 mm, bevægelig

- ▲ Dobbelt-sided griptrin
- ▲ Pris pr. stk.

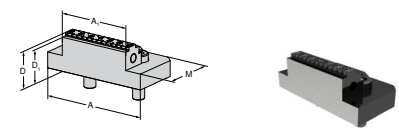

Til skruestikbredde	A	A ₁	D	D ₁	D ₂	E	M	M ₁	M ₂
125	95	65	33	30			57		

DKK
1.466,00

Y4	NCG	H5G / -S / -Z	X5G-Z / -S	ESG 4	ESG 5	HDG 2	ZSG 4	ZSG mini	DSG 4	Verso	HSG
80 878 51900							●				

Oversigt systembakker

Pendulbakke, bevægelig

- ▲ Rummer 6 gange vendbare bakker
- ▲ Pris pr. stk.

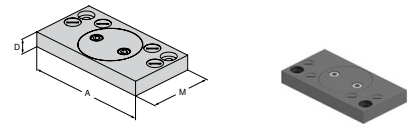

Til skruestikbredde	A	A ₁	D	D ₁	D ₂	E	M	M ₁	M ₂	DKK	Y4	NCG	H5G / -S / -Z	X5G-Z / -S	ESG 4	ESG 5	HDG 2	ZSG 4	ZSG mini	DSG 4	Verso	HSG	
80	125		19				76			3.059,00					●				●		●		
125	180		22				95			3.186,00					●				●		●		
160	256		22				170			5.430,00					●				●		●		

Adapterbakke

- ▲ Rummer 6 gange vendbare bakker
- ▲ Pris pr. stk.

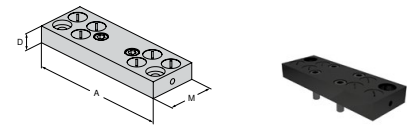

Til skruestikbredde	A	A ₁	D	D ₁	D ₂	E	M	M ₁	M ₂	DKK	Y4	NCG	H5G / -S / -Z	X5G-Z / -S	ESG 4	ESG 5	HDG 2	ZSG 4	ZSG mini	DSG 4	Verso	HSG	
80	125		19				48			2.177,00					●								
125	180		22				62			2.588,00					●								
160	256		22				125			3.620,00					●								

6-fags vendebakke

- ▲ 1 = Glat, Wolfram-Carbid belagt
- ▲ 2 = Grip med trin 3 mm
- ▲ 3 = Grip med trin 8 mm
- ▲ 4 = Grip med trin 18 mm
- ▲ 5 = Grip rund med trin 8 mm
- ▲ 6 = Grip rund
- ▲ M_{max} = 60 Nm
- ▲ Inkl. fastspændingsbolte

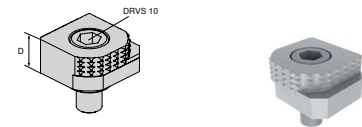

Til skruestikbredde	A	A ₁	D	D ₁	D ₂	E	M	M ₁	M ₂	DKK	Y4	NCG	H5G / -S / -Z	X5G-Z / -S	ESG 4	ESG 5	HDG 2	ZSG 4	ZSG mini	DSG 4	Verso	HSG	
			18							603,00			●	●	●	●					●	●	
													●	●	●	●					●	●	

6-fags vendebakke, Carbide grip

- ▲ 1 = Glat
- ▲ 2 = Carbide grip
- ▲ 3 = Carbide grip med trin 3 mm
- ▲ 4 = Carbide grip med trin 8 mm
- ▲ 5 = Carbide grip rund med trin 8 mm
- ▲ 6 = Carbide grip rund
- ▲ Inkl. fastspændingsbolte

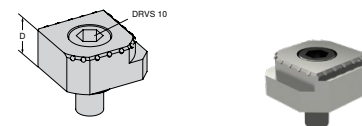

Til skruestikbredde	A	A ₁	D	D ₁	D ₂	E	M	M ₁	M ₂	DKK	Y4	NCG	H5G / -S / -Z	X5G-Z / -S	ESG 4	ESG 5	HDG 2	ZSG 4	ZSG mini	DSG 4	Verso	HSG	
			18							875,00			●	●	●	●					●	●	
													●	●	●	●					●	●	

ESG 5



Den optimerede ESG 5 – maksimal præcision og processikkerhed

Den nye ESG 5 overtager alle de populære funktioner fra sin forgænger og sætter barren en hel del højere i forhold til brugervenlighed og holdbarhed. Optimeret håndtering og forbedret levetid var topprioriteter ved opdateringen af enkel skruestikken.

Dine fordele:

- ▲ Især velegnet til 2-sidet bearbejdning gennem høj vinkelnøjagtighed
- ▲ Kompakt design med ideel tilgængelighed
- ▲ Bakkeskift nemt og hurtigt, med to skruer
- ▲ Samme spændområder, meget bedre interfererenskontur, stort modulopbygget bakkeprogram
- ▲ Bæredygtig model med forniklet grundkrop sikrer lang levetid

Ospænding/justering:



Fastgørelse med nulpunkt-spændesystem
ESG 5 – 80 mm L-130 mm + L-190 mm
ESG 5 – 125 mm L-160 mm + L-235 mm

1 antræksbolt + MNG-positioneringsstift

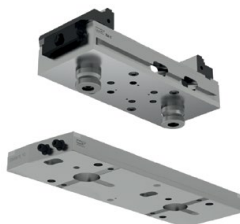

Fastgørelse med nulpunkt-spændesystem
ESG 5 – 125 mm + L-300 mm
ESG 5 – 160 mm + L-280 mm + L-480 mm

2 antræksbolte + MNG-positioneringsstifte



I alle varianter er der 12^{JS} præcisionshuller, som ESG 5 kan positioneres præcist med. Alle varianter kan fastgøres med skruer ovenfra gennem grundkroppen.

Opspænding/justering:

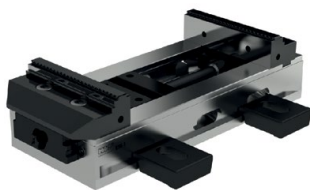

ESG 5 – 125 mm L-235 mm + L-300 mm

ESG 5 – 160 mm L-280 mm + L-480 mm

Disse 4 varianter kan også opspændes med spændejern.

Spændkraft:

Tilspændingsmoment / spændkraft ESG 5 – 80 mm

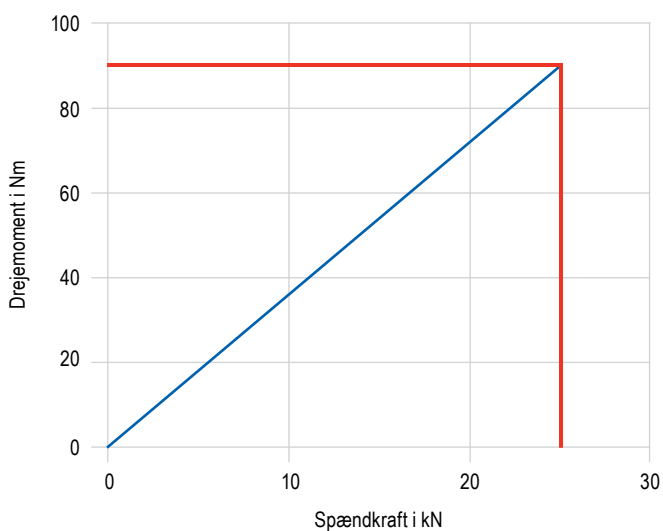

Tilspændingsmoment / spændkraft ESG 5 – 125 mm

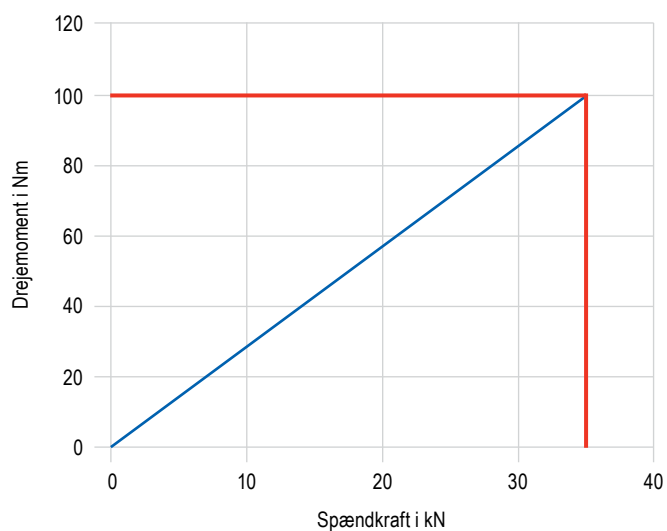

Tilspændingsmoment / spændkraft ESG 5 – 160 mm

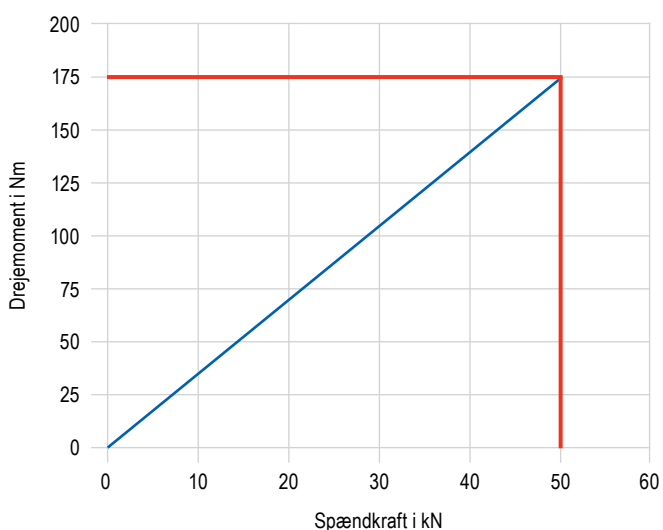

SoloClamp – ESG 5

- ▲ Enkel skruestik uden systembakker
- ▲ Især velegnet til 2-sidet bearbejdning gennem høj vinkeløjagtighed
- ▲ $\pm 0,01$ mm gentagelsesøjagtighed mellem spændeprocesserne
- ▲ til PNG og MNG

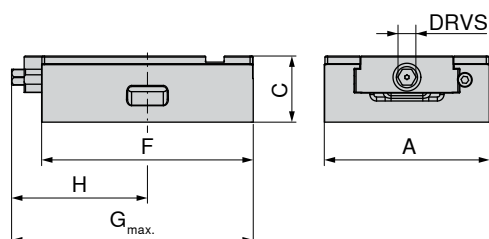
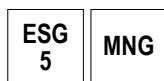

A	C $\pm 0,01$	F	G _{max.}	H	DRVS	MXC	WT	80 857 ...	
mm	mm	mm	mm	mm	mm	kN	kg	DKK	Y4
80	50	130	155,0	82	12	25	2,9	4.136,00	08500
80	50	190	203,0	102	12	25	4,4	4.974,00	08600
125	50	160	169,0	103	12	35	6,0	5.430,00	15000
125	50	235	235,0	132	12	35	8,4	6.934,00	15100
125	50	300	300,0	170	12	35	10,5	9.200,00	15200
160	70	280	309,0	169	14	50	25,0	12.791,00	26100
160	70	480	512,5	267	14	50	30,0	15.259,00	26200

Art. nr.	til nulpunktspændesystem			MNG	MNG mini	PNG	LANG Quick Point	
	Type	Bredde i mm	Højde i mm				96 x 96	52 x 52
80 857 08500	ESG 5	80	130	✓	✓	✗	✗	✓
80 857 08600		80	190	✓	✗	✓	✗	✓
80 857 15000		125	160	✓	✗	✓	✓	✓
80 857 15100		125	235	✓	✗	✓	✓	✗
80 857 15200		125	300	✓	✗	✓	✓	✗
80 857 26100		160	280	✓	✗	✓	✓	✗
80 857 26200		160	480	✓	✗	✓	✗	✗

Skruestikguide

Dimensioner	63+64	Dimensionstabeller til de forskellige bakker	65
Systemtilbehør	66	MNG-/PNG-nulpunkt-spændesystem	134-163
Alment tilbehør	164-183		

SoloClamp – ESG 5

- ▲ indkapslet enkel skruestik til Erowa ITS 148
- ▲ Uden systembakker
- ▲ Især velegnet til 2-sidet bearbejdning gennem høj vinkeløjagtighed
- ▲ $\pm 0,01$ mm gentagelsesøjagtighed mellem spændeprocesserne

ESG
5

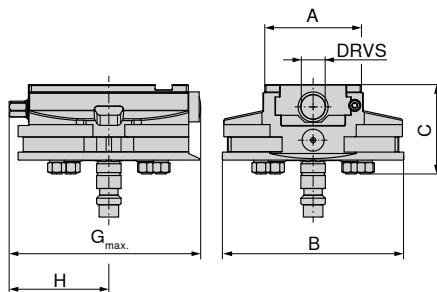

80 857 ...

DKK
Y4

10.248,00 08900

A	B	C	G _{max.}	H	DRVS	MXC	WT
mm	mm	mm	mm	mm	mm	kN	kg
80	148	73	157	81	12	25	5,6

Skruestikguide

Dimensioner	63+64	Dimensionstabeller til de forskellige bakker	65
Systemtilbehør	66	MNG-/PNG-nulpunkt-spændesystem	134-163
Alment tilbehør	164-183		

ESG 5 dimensioner

Grundkrop bredde 80 mm
og længde 130 mm

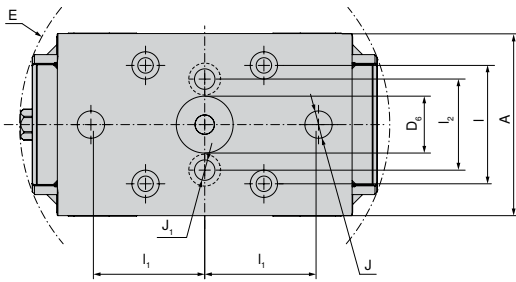

A	D ₆ H ₆	E	l ₁ ±0.015	l ₂ ±0.015	l ₂	J H ₇	J ₁
mm	mm	mm	mm	mm	mm	mm	mm
80	25	163	52	50	40	12	9

Grundkrop bredde 80 mm
og længde 190 mm

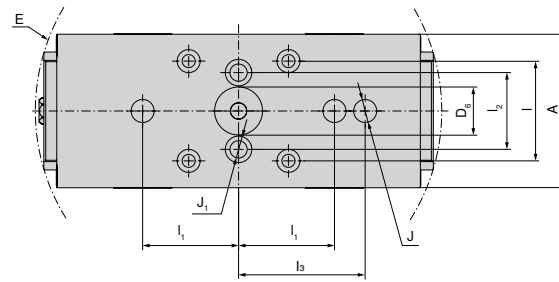

A	D ₆ H ₆	E	l ₁ ±0.015	l ₂ ±0.015	l ₂	l ₃ ±0.015	J H ₇	J ₁
mm	mm	mm	mm	mm	mm	mm	mm	mm
80	25	213	52	50	40	66	12	9

Grundkrop bredde 125 mm
og længde 160 mm

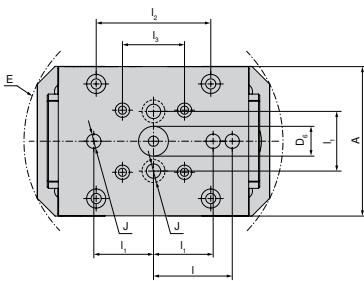

A	D ₆ H ₆	E	l ₁ ±0.015	l ₂ ±0.015	l ₂	l ₃ ±0.015	J H ₇
mm	mm	mm	mm	mm	mm	mm	mm
125	25	218	66	50	96	52	12

Grundkrop bredde 125 mm
og længde 235 mm

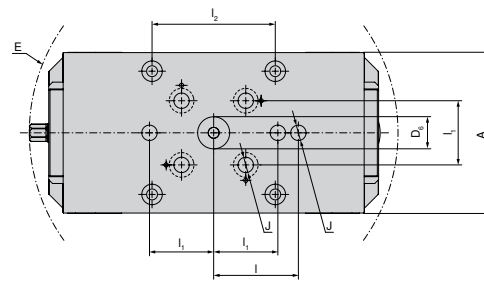

A	D ₆ H ₆	E	l ₁ ±0.015	l ₂ ±0.015	l ₂	J H ₇
mm	mm	mm	mm	mm	mm	mm
125	25	288	66	50	96	12

Grundkrop bredde 125 mm
og længde 300 mm

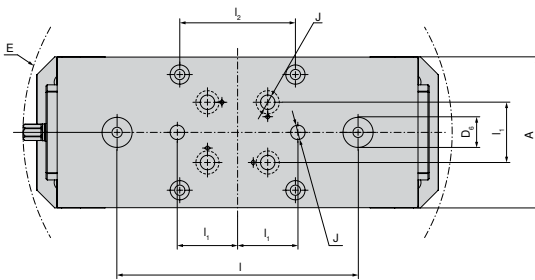

A	D ₆ H ₆	E	l ₁ ±0.015	l ₂ ±0.015	l ₂	J H ₇
mm	mm	mm	mm	mm	mm	mm
125	25	357	200	50	96	12

ESG 5 dimensioner

Grundkrop bredde 160 mm
og længde 280 mm

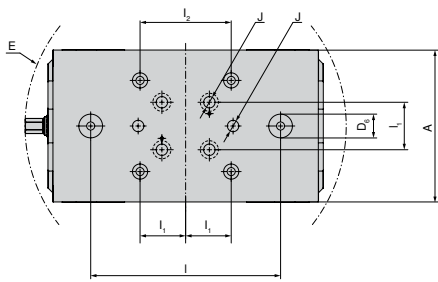

A	D ₆ H6	E	I ±0,015	I ₁ ±0,015	I ₂	J H7
mm	mm	mm	mm	mm	mm	mm
160	25	339	200	50	96	12

Grundkrop bredde 160 mm
og længde 480 mm

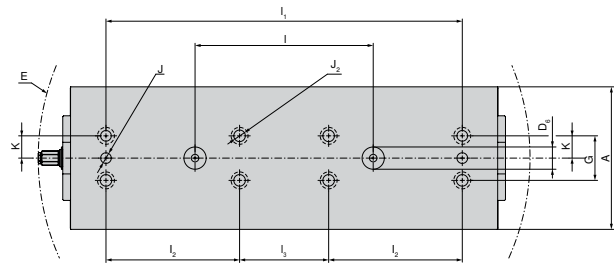

A	D ₆ H6	E	I ±0,015	I ₁ ±0,015	I ₂	I ₃ ±0,015	J H7	J ₂ F7	K ±0,02	G
mm	mm	mm	mm	mm	mm	mm	mm	mm	mm	mm
160	25	553	200	400	150	100	12	12	25	50

ESG 5 dimensionstabel til de forskellige bakker

Med vendebakke grip 3 mm, fast og bevægelig

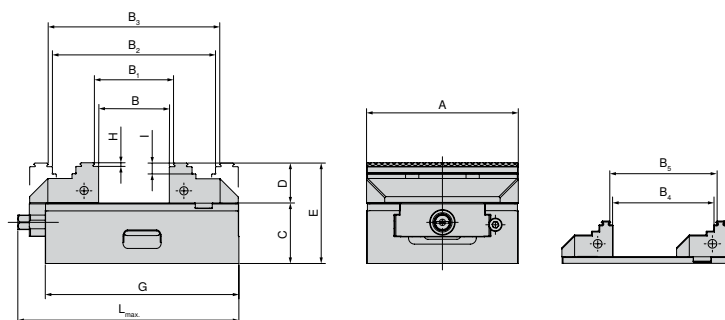

A mm	B mm	B ₁ mm	B ₂ mm	B ₃ mm	B ₄ mm	B ₅ mm	C mm	D mm	E mm	G mm	H mm	I mm	L _{max.} mm	Art. nr. Systembakker
80	0-49	4-53	59-107	63-111	30-78	34-82	50	28	78	130	3	8	155	80 901 306 + 80 878 810
80	0-109	4-113	59-167	63-171	29-134	35-136	50	28	78	190	3	8	206	80 901 306 + 80 878 810
125	0-57	8-64	77-134	84-141	40-95	47-102	50	33	83	160	3	9	183	80 857 30000 + 80 878 510
125	0-127	8-134	77-204	84-211	40-165	47-172	50	33	83	235	3	9	250	80 857 30000 + 80 878 510
125	0-197	8-204	77-274	84-281	40-235	47-242	50	33	83	300	3	9	320	80 857 30000 + 80 878 510
160	0-121	8-128	118-238	125-245	-	-	70	50	120	280	3	10	328	80 901 300 + 80 878 610
160	0-324	8-331	118-441	125-448	-	-	70	50	120	480	3	10	506	80 901 300 + 80 878 610

Med 5-akset bakker

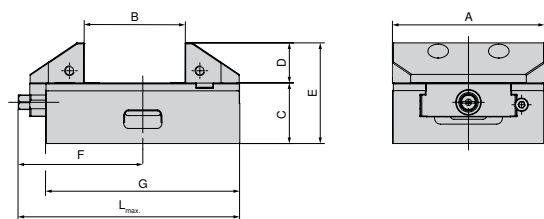

A mm	B mm	C mm	D mm	E mm	F mm	G mm	L _{max.} mm	Art. nr. Systembakker
125	25-82	50	33	83	103	160	183	80 857 30200 + 80 857 30100
125	25-152	50	33	83	132	235	250	80 857 30200 + 80 857 30100
125	25-222	50	33	83	170	300	320	80 857 30200 + 80 857 30100

Oversigt systembakker

Vendebakke, glat, fast

▲ Pris pr. stk.

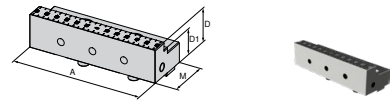

Til skruestikbredde	A	A ₁	D	D ₁	D ₂	E	M	M ₁	M ₂	DKK	Y4	NCG	H5G / -S / -Z	X5G-Z / -S	ESG 4	ESG 5	HDG 2	ZSG 4	ZSG mini	DSG 4	Verso	HSG		
80	80		28	20			40			1.459,00	80 857 30400				●									
125	125		33	25			57			2.827,00	80 857 30300				●									

Vendebakke, glat, bevægelig

▲ Pris pr. stk.

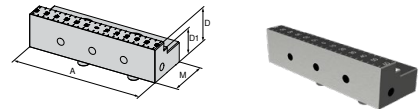

Til skruestikbredde	A	A ₁	D	D ₁	D ₂	E	M	M ₁	M ₂	DKK	Y4	NCG	H5G / -S / -Z	X5G-Z / -S	ESG 4	ESG 5	HDG 2	ZSG 4	ZSG mini	DSG 4	Verso	HSG	
80	80		28	20			40			1.459,00	80 878 34700				●								
125	125		33	25			57			2.827,00	80 878 34600				●		●						

Vendebakke, grip 3 mm, fast

▲ Pris pr. stk.

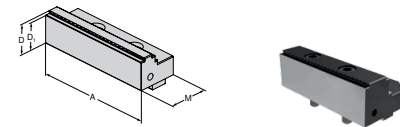

Til skruestikbredde	A	A ₁	D	D ₁	D ₂	E	M	M ₁	M ₂	DKK	Y4	NCG	H5G / -S / -Z	X5G-Z / -S	ESG 4	ESG 5	HDG 2	ZSG 4	ZSG mini	DSG 4	Verso	HSG	
80	80		28	25			40			1.219,00	80 901 306				●	●							
125	125		33	30			57			1.661,00	80 857 30000				●	●							
160	160		50	47			81			3.022,00	80 901 300				●	●							

Vendebakke, grip 3 mm, bevægelig

▲ Pris pr. stk.

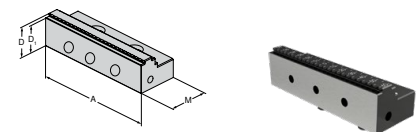

Til skruestikbredde	A	A ₁	D	D ₁	D ₂	E	M	M ₁	M ₂	DKK	Y4	NCG	H5G / -S / -Z	X5G-Z / -S	ESG 4	ESG 5	HDG 2	ZSG 4	ZSG mini	DSG 4	Verso	HSG	
80	80		28	25			40			1.010,00	80 878 810				●	●							
125	125		33	30			57			1.129,00	80 878 510				●	●							
160	160		50	47			81			3.022,00	80 878 610				●	●							

Oversigt systembakker

5-akset vendebakke, fast

▲ Pris pr. stk.

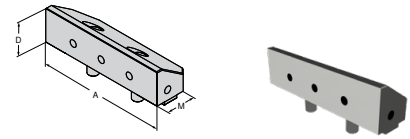

Til skruestikbredde	A	A ₁	D	D ₁	D ₂	E	M	M ₁	M ₂	DKK	Y4	NCG	H5G / -S / -Z	X5G-Z / -S	ESG 4	ESG 5	HDG 2	ZSG 4	ZSG mini	DSG 4	Verso	HSG	
125	125		33				44,5			1.676,00						●							

5-akset vendebakke, grip, fast

▲ Pris pr. stk.

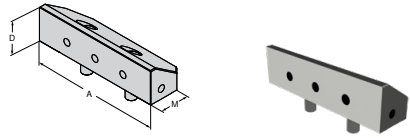

Til skruestikbredde	A	A ₁	D	D ₁	D ₂	E	M	M ₁	M ₂	DKK	Y4	NCG	H5G / -S / -Z	X5G-Z / -S	ESG 4	ESG 5	HDG 2	ZSG 4	ZSG mini	DSG 4	Verso	HSG	
125	125		33				44,5			1.676,00						●							

Blød bakke, stål, fast

- ▲ Materiale: 16MnCr5
- ▲ Til fremstilling af formbakker
- ▲ Pris pr. stk.

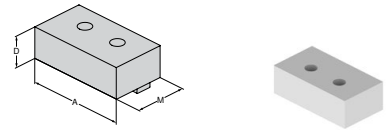

Til skruestikbredde	A	A ₁	D	D ₁	D ₂	E	M	M ₁	M ₂	DKK	Y4	NCG	H5G / -S / -Z	X5G-Z / -S	ESG 4	ESG 5	HDG 2	ZSG 4	ZSG mini	DSG 4	Verso	HSG	
80	80		28				48			778,00					●	●							
125	125		40				68			935,00					●	●							

Blød bakke, stål, bevægelig

- ▲ Materiale: 16MnCr5
- ▲ Til fremstilling af formbakker
- ▲ Pris pr. stk.

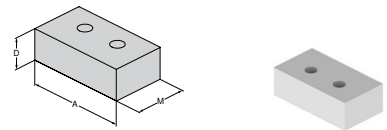

Til skruestikbredde	A	A ₁	D	D ₁	D ₂	E	M	M ₁	M ₂	DKK	Y4	NCG	H5G / -S / -Z	X5G-Z / -S	ESG 4	ESG 5	HDG 2	ZSG 4	ZSG mini	DSG 4	Verso	HSG	
80	80		28				48			666,00					●	●							
125	125		40				68			838,00					●	●		●					

HDG 2

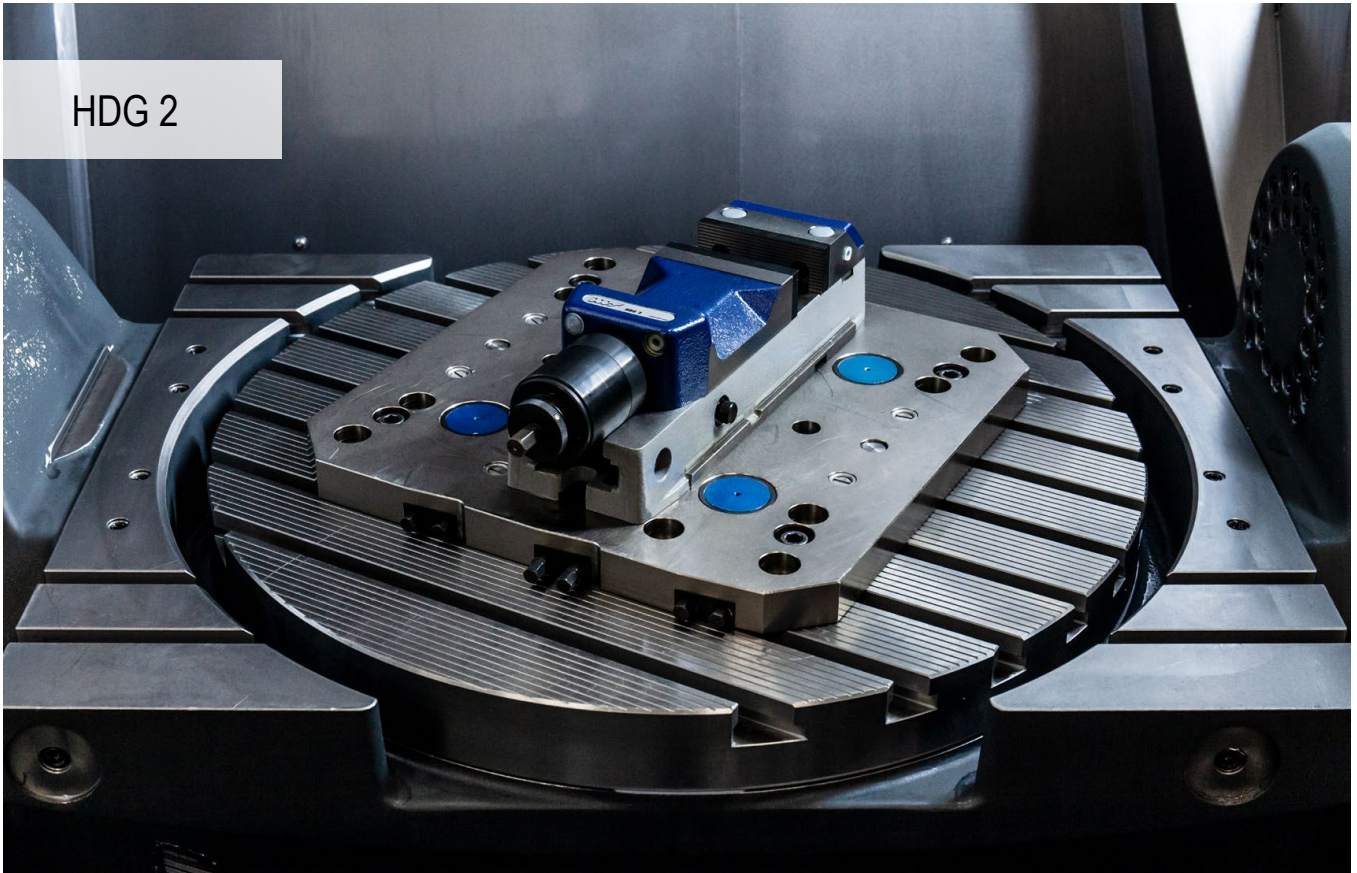

Populært højtryk-spændesystem

Mekanisk maskinskruestik med trinløs kraftindstilling fra 10 % til 100 % med kun en håndsvingsomdrejning og altid samme håndsvingsposition. Hurtig justering af spændområdet via stikbolte.

Dine fordele:

- ▲ Spar både tid og kræfter – kun én håndsvingsomdrejning
- ▲ Spændetid < 1 sekund
- ▲ Nem håndtering
- ▲ Trinløs indstilling uden brug af værktøj
- ▲ Høj bearbejdningspræcision

Opspænding/justering:



Justering via præcisions T-not møtrikker på notbordet med længde- eller tværnot 20^{H7} i grundkroppen



Opspænding med skruer gennem grundkroppen eller med spændejern

SoloClamp – HDG 2

- ▲ Højtryk skruestik
- ▲ Trinløs kraftindstilling
- ▲ Mekanisk krafttransmission
- ▲ Spændkraft med kun en håndsvingsomdrejning
- ▲ Bevægelige bakker, forarbejdet til fastgørelse af bakker til spændeområdeudvidelser

Leveringsomfang:

Højtryk skruestik inkl. 4 spændejern, håndsving, 2 forsatsbakker profileret og hærdet

**HDG
2**

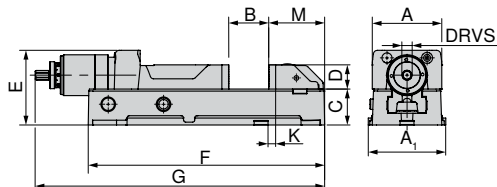

A	A ₁	B	C ^{+0/-0.02}	D	E	F	G _{max.}	K _{±0.015}	M	DRVS	MXC	WT	80 892 ...
mm	mm	mm	mm	mm	mm	mm	mm	mm	mm	mm	kN	kg	DKK Y4
100	112	0 - 159	52	35	108	342	521	11	81	12	4 - 30	20	15.334,00 100
125	140	0 - 201	62	40	118	400	584	28	85	12	4 - 40	27	17.503,00 125
160	176	0 - 300	78	50	149	544	784	40	112	12	5 - 60	55	25.956,00 160

Skruestikguide

Dimensioner	71	Systemtilbehør	69-71
Alment tilbehør	164-183		

Oversigt systembakker

Bakker til udvidelse af spændeområde

▲ Pris pr. sæt (1 fast og 1 bevægelig bakke)

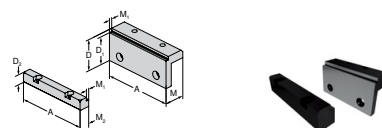

Til skruestikbredde	A	A ₁	D	D ₁	D ₂	E	M	M ₁	M ₂	DKK	Y4	NCG	H5G / +S / -Z	X5G-Z / -S	ESG 4	ESG 5	HDG 2	ZSG 4	ZSG mini	DSG 4	Verso	HSG	
100			56	50	22		37	5	19	2.738,00	80 892 225						●						
125			56	50	22		37	5	19	3.695,00	80 892 226						●						
160			71	65	23		47	5	23,5	4.017,00	80 892 227						●						

Visning af det udvidede spændeområde



A	B	D	Artikelnummer skruestik	Artikelnummer bakker
100	118 - 278	56	80 892 100	80 892 225
125	137 - 338	56	80 892 125	80 892 226
160	169 - 470	71	80 892 160	80 892 227

SoloClamp – HDG 2

▲ Grundkrop forlænger

HDG
2

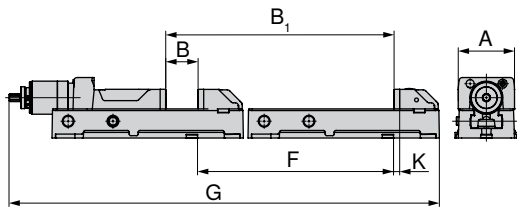

A	B	B ₁	F	G	K
mm	mm	mm	mm	mm	mm
100	0-159	350-509	450	871,3	11
125	0-201	410-611	410	994,1	28
160	0-300	550-850	550	1334,15	40

80 892 ...

DKK
Y4

8.677,00 51000
9.574,00 51100
13.015,00 51200

Vist med grundkrop forlængelse

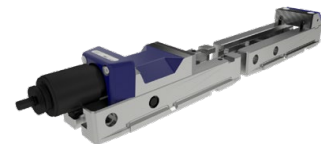

A	B	D	Artikelnummer skruestik	Artikelnummer forlænger
100	350 - 509	35	80 892 100	80 892 51000
125	410 - 611	40	80 892 125	80 892 51100
160	550 - 850	50	80 892 160	80 892 51200

HDG 2 dimensioner

Grundkrop bredde 100 mm, 125 mm, 160 mm

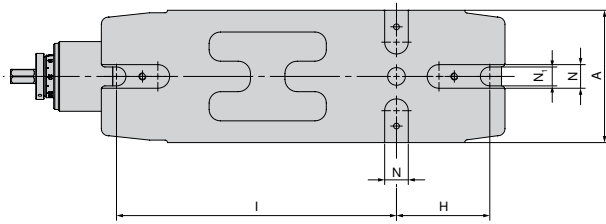

A mm	H mm	I mm	N _{H7} mm	N ₁ mm
100	80	240	20	15
125	100	280	20	18
160	130	380	20	22

Oversigt system-tilbehør

Vinkelgear

HDG
2



80 892 ...

Til bredde mm	DKK Y4	
100/125	3.441,00	314
160	3.733,00	315

Håndsving

▲ Til hurtigjustering

HDG
2



80 892 ...

Til bredde mm	DRVS mm	DKK Y4	
100/125	12	573,00	124
160	12	711,00	164

ZSG 4



Den optimerede ZSG 4 – maksimal præcision og processikkerhed

Den nye ZSG 4 bevarer alle de gode egenskaber fra sin forgænger og hæver standarden markant med hensyn til brugervenlighed og holdbarhed. Optimeret håndtering og forbedret holdbarhed stod øverst på listen i opdateringen for den populære centrerede skruestik.

Dine fordele:

- ▲ Især velegnet til 2-sidet bearbejdning gennem høj vinkeløjagtighed
- ▲ Kompakt design med ideel tilgængelighed
- ▲ Bakkeskift nemt og hurtigt, med to skruer
- ▲ Samme spændområder, meget bedre interfererenskontur, stort modulopbygget bakkeprogram
- ▲ Bæredygtig model med forniklet grundkrop sikrer lang levetid



Ospænding/justering:



Fastgørelse med nulpunkt-spændesystem
ZSG 4 – 80 mm L-130 mm + L-190 mm
ZSG 4 – 125 mm L-160 mm + L-235 mm

1 antræksbolt + MNG-positioneringsstift

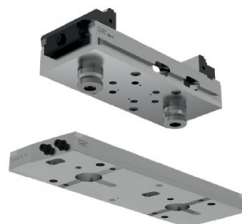

Fastgørelse med nulpunkt-spændesystem
ZSG 4 – 125 mm + L-300 mm
ZSG 4 – 160 mm + L-280 mm + L-480 mm

2 antræksbolt + MNG-positioneringsstift



I alle varianter forefindes Ø12^{IS} præcisionshuller, som ZSG 4 kan positioneres præcist med. Alle varianter kan fastgøres med skruer ovenfra gennem grundkroppen.

Opspænding/justering:



ZSG 4 – 125 mm L-235 mm + L-300 mm
ZSG 4 – 160 mm L-280 mm + L-480 mm

Som alternativ kan disse 4 varianter også opspændes med spændejern.



ZSG 4 – 80 mm L-130 mm + L-190 mm
ZSG 4 – 125 mm L-160 mm + L-235 mm + L-300 mm
ZSG 4 – 160 mm L-280 mm

Alle 5 varianter fås også med monteringshuller til LANG-nulpunkt-spændesystemet.

Spændkraft:

Tilspændingsmoment / spændkraft ZSG 4 – 80 mm

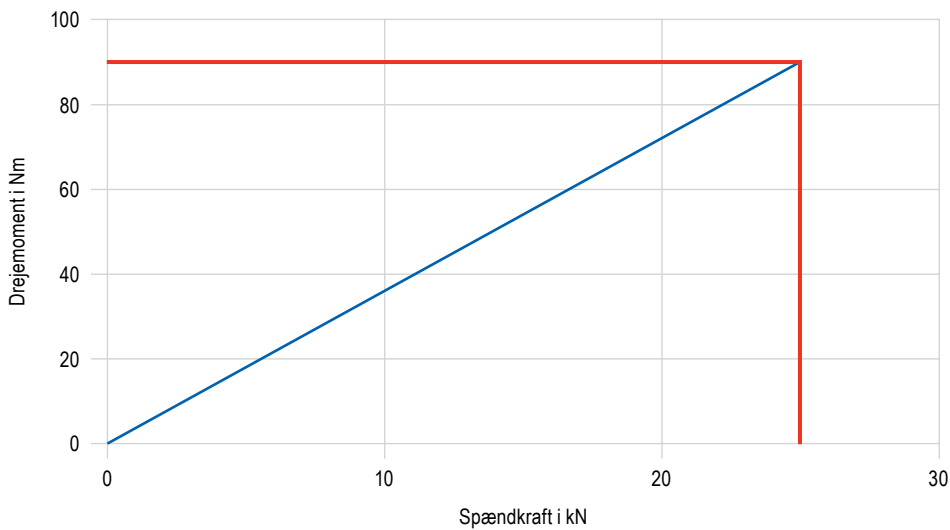

Spændkraft:

Tilspændingsmoment / spændkraft ZSG 4 – 125 mm

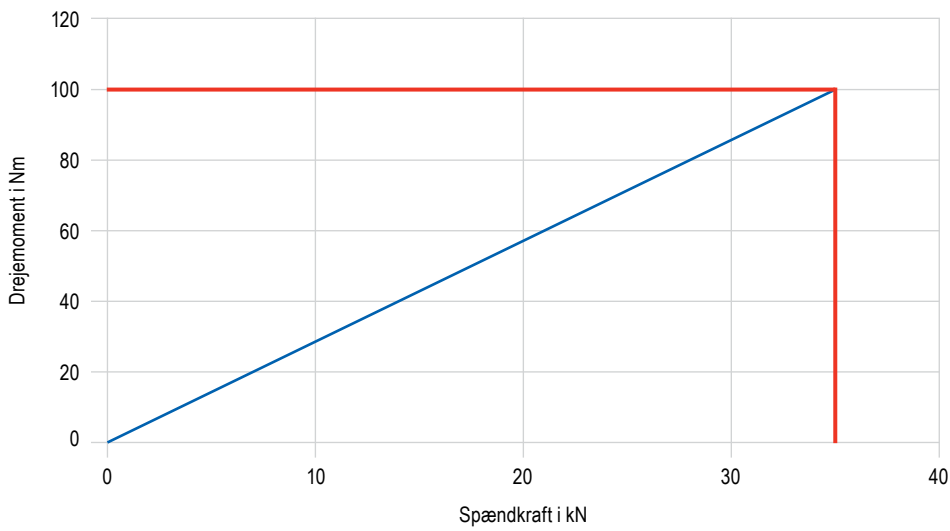

Tilspændingsmoment / spændkraft ZSG 4 – 160 mm

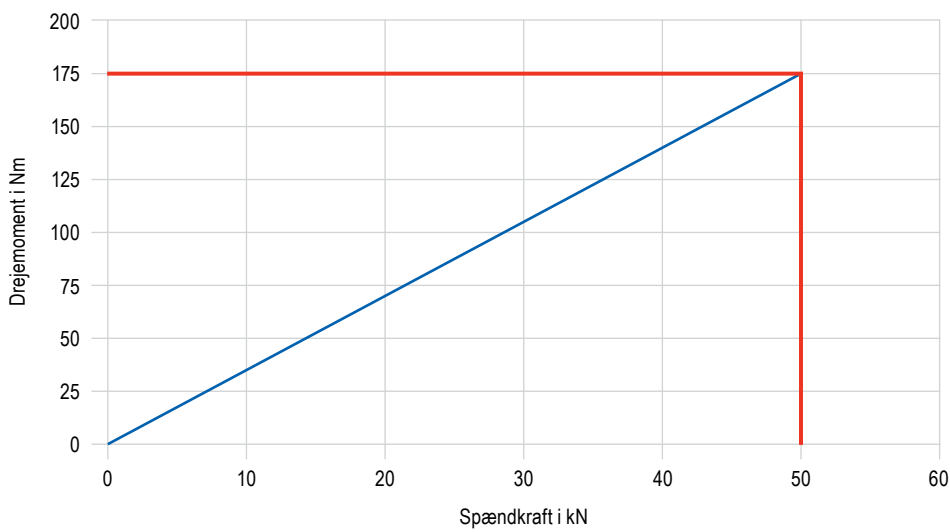

CentriClamp – ZSG 4

- ▲ Indkapslet centrisk skruestik
- ▲ Uden systembakker
- ▲ Kuglelejret spindel
- ▲ ±0,01 mm gentagelsesnøjagtighed mellem spændeprocesserne
- ▲ Til PNG og MNG

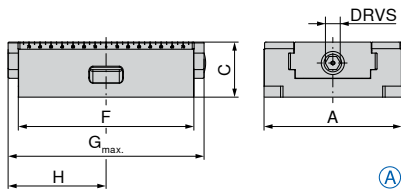

Indvendig betjeningspindel

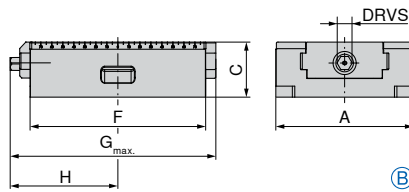

Udvendig betjeningspindel



A	C _{±0.01}	F	G _{max.}	H	DRVS	MXC	WT	Betegnelse	80 878 ...
mm	mm	mm	mm	mm	mm	kN	kg		DKK Y4
80	50	130	157	81	12	25	3,1	A	4.136,00 08500
80	50	190	206	104	12	25	4,5	B	4.974,00 08600
125	50	160	200	111,5	12	35	6,3	A	5.430,00 15000
125	50	235	272	143,5	12	35	9,5	B	6.934,00 15100
125	50	300	340	181	12	35	12,5	B	8.452,00 15200
160	70	280	315	172	14	50	25,0	A	12.791,00 26100
160	70	480	524	276	14	50	35,0	B	24.160,00 26200

Art. nr.	til nulpunktspændesystem			MNG	MNG mini	PNG	LANG Quick Point	
	Type	Bredde i mm	Længde i mm				96 x 96	52 x 52
80 878 08500	ZSG 4	80	130	✓	✓	✗	✗	✓
80 878 08600		80	190	✓	✗	✓	✗	✓
80 878 15000		125	160	✓	✗	✓	✓	✓
80 878 15100		125	235	✓	✗	✓	✓	✗
80 878 15200		125	300	✓	✗	✓	✓	✗
80 878 26100		160	280	✓	✗	✓	✓	✗
80 878 26200		160	480	✓	✗	✓	✗	✗

Skruestikguide

Dimensioner	78+79	Dimensionstabeller til de forskellige bakker	80-83
Systemtilbehør	85-90	MNG-/PNG-nulpunkt-spændesystem	134-163
Alment tilbehør	164-183		

CentriClamp – ZSG 4

- ▲ Indkapslet centrisk skruestik
- ▲ Med bakke, grip 3 mm
- ▲ Kuglelejret spindel
- ▲ ±0,01 mm gentagelsesnøjagtighed i mellem spændeprocesserne
- ▲ Til PNG og MNG

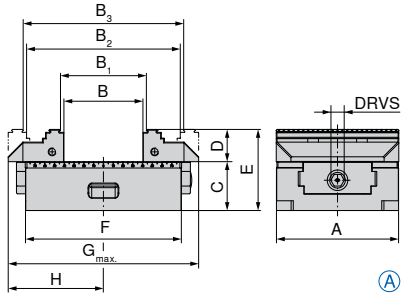
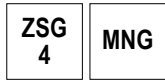

Indvendig betjeningsspindel

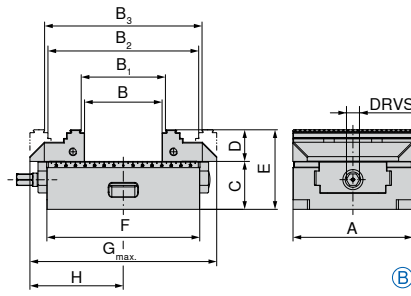

Udvendig betjeningsspindel



A	B	B ₁	B ₂	B ₃	C ±0,01	D	E	F	G _{max}	H	DRVS	MXC	WT	Betegnelse	DKK	
mm	mm	mm	mm	mm	mm	mm	mm	mm	mm	mm	mm	kN	kg		Y4	
80	0 - 59	4 - 63	59 - 117	63 - 121	50	28	78	130	157	81	12	25	3,9	A	5.812,00	08700
80	0 - 123	4 - 127	59 - 181	63 - 185	50	28	78	190	206	104	12	25	5,5	B	6.650,00	08800
125	0 - 80	8 - 87	77 - 156	84 - 163	50	33	83	160	208	111,5	12	35	8,7	A	7.330,00	15300
125	0 - 155	8 - 162	77 - 218	84 - 225	50	33	83	235	272	143,5	12	35	12,0	B	8.826,00	15400
125	0 - 220	8 - 227	77 - 296	84 - 303	50	33	83	300	348	181	12	35	14,0	B	10.397,00	15500

80 878 ...

1 Det er ikke muligt at montere topkæber med en højde på 40 mm, hvis denne højde ønskes, så brug de vendbare bakker D = 40 mm (80 878 520).

til nulpunktspændesystem							LANG Quick Point		LANG Quick Point	
Art. nr.	Type	Bredde i mm	Længde i mm	MNG	MNG mini	PNG	96 x 96	52 x 52		
80 878 08700	ZSG 4	80	130	✓	✓	✗	✗	✓		
80 878 08800		80	190	✓	✗	✓	✗	✓		
80 878 15300		125	160	✓	✗	✓	✓	✓		
80 878 15400		125	235	✓	✗	✓	✓	✗		
80 878 15500		125	300	✓	✗	✓	✓	✗		

Skruestikguide

Dimensioner	78-79	Dimensionstabeller til de forskellige bakker	80-83
Systemtilbehør	85-90	MNG-/PNG-nulpunkt-spændesystem	134-163
Alment tilbehør	164-183		

CentriClamp – ZSG 4

- ▲ Indkapslet centrisk skruestik til Erowa ITS 148
- ▲ Uden systembakker
- ▲ kuglelejret spindel
- ▲ $\pm 0,01$ mm gentagelsesnøjagtighed mellem spændeprocesserne

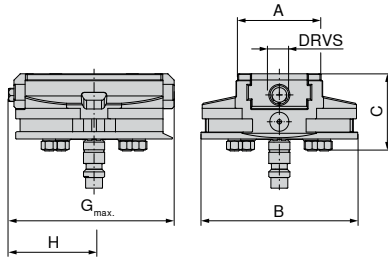

A	B	C	G _{max.}	H	DRVS	MXC	WT
mm	mm	mm	mm	mm	mm	kN	kg
80	148	73	157	81	12	25	5,6

80 878 ...

DKK
Y4

10.248,00 08900

Skruestikguide

Dimensioner	78+79	Dimensionstabeller til de forskellige bakker	80-83
Systemtilbehør	85-90	MNG-/PNG-nulpunkt-spændesystem	134-163
Alment tilbehør	164-183		

ZSG 4 dimensioner

Grundkrop bredde 80 mm og længde 130 mm

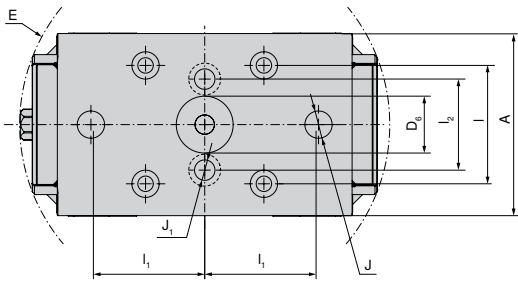

A	D ₆ H6	E	l ₁ ±0,015	l ₁ ±0,015	l ₂	J H7	J ₁
mm	mm	mm	mm	mm	mm	mm	mm
80	25	163	52	50	40	12	9

Grundkrop bredde 80 mm og længde 190 mm

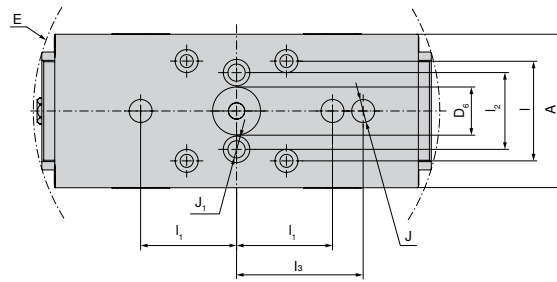

A	D ₆ H6	E	l ₁ ±0,015	l ₁ ±0,015	l ₂	l ₃ ±0,015	J H7	J ₁
mm	mm	mm	mm	mm	mm	mm	mm	mm
80	25	213	52	50	40	66	12	9

Grundkrop bredde 125 mm og længde 160 mm

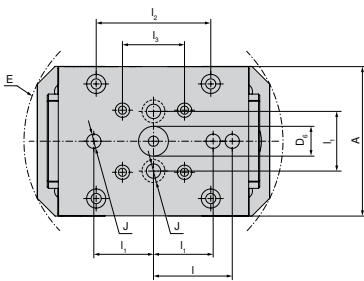

A	D ₆ H6	E	l ₁ ±0,015	l ₁ ±0,015	l ₂	l ₃ ±0,015	J H7
mm	mm	mm	mm	mm	mm	mm	mm
125	25	218	66	50	96	52	12

Grundkrop bredde 125 mm og længde 235 mm

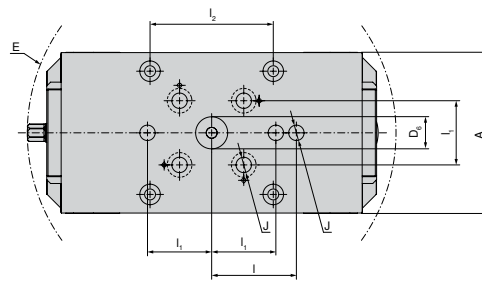

A	D ₆ H6	E	l ₁ ±0,015	l ₁ ±0,015	l ₂	J H7
mm	mm	mm	mm	mm	mm	mm
125	25	288	66	50	96	12

Grundkrop bredde 125 mm og længde 300 mm

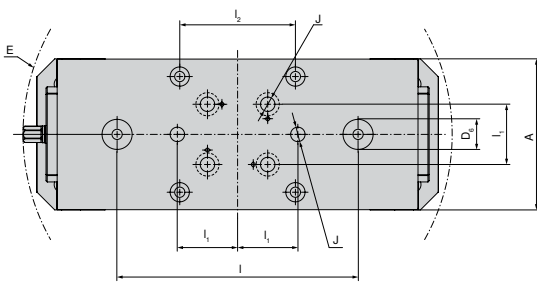

A	D ₆ H6	E	l ₁ ±0,015	l ₁ ±0,015	l ₂	J H7
mm	mm	mm	mm	mm	mm	mm
125	25	357	200	50	96	12

ZSG 4 dimensioner

Grundkrop bredde 160 mm og længde 280 mm

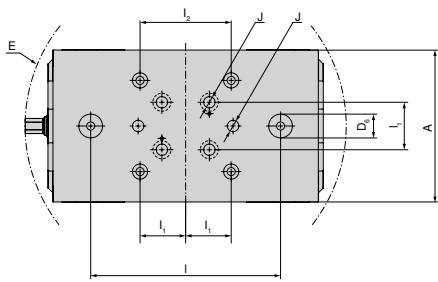

A	D ₆ H6	E	I ±0,015	I ₁ ±0,015	I ₂	J H7
mm	mm	mm	mm	mm	mm	mm
160	25	339	200	50	96	12

Grundkrop bredde 160 mm og længde 480 mm

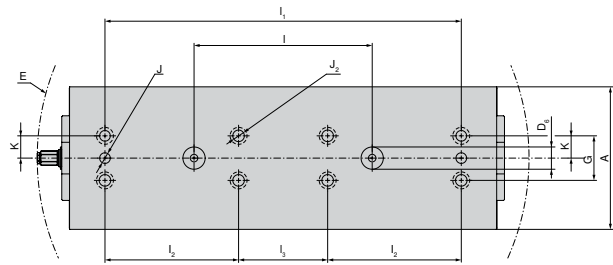

A	D ₆ H6	E	I ±0,015	I ₁ ±0,015	I ₂	I ₃ ±0,015	J H7	J ₂ F7	K ±0,02	G
mm	mm	mm	mm	mm	mm	mm	mm	mm	mm	mm
160	25	553	200	400	150	100	12	12	25	50

ZSG 4 dimensionstabel til de forskellige bakker

Med kombibakker

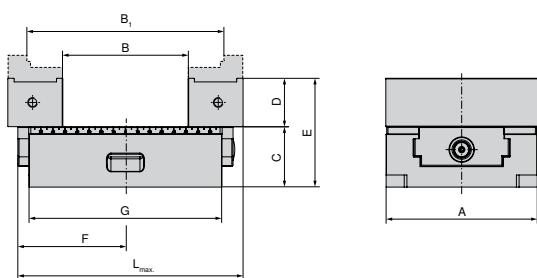

A mm	B mm	B ₁ mm	C mm	D mm	E mm	F mm	G mm	L _{max} mm	Art. nr. Systembakker
125	23 - 103	82 - 161	50	40	90	111,5	160	208	2 x 80 878 530
125	23 - 165	82 - 223	50	40	90	143,5	235	272	2 x 80 878 530
125	23 - 241	82 - 300	50	40	90	181	300	348	2 x 80 878 530

Med pendul- og adapterplade

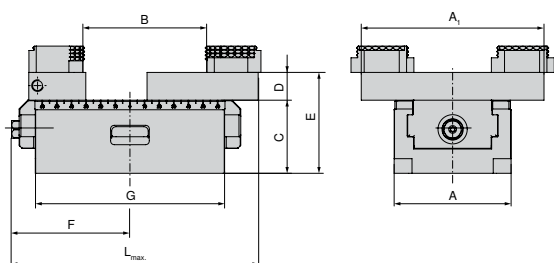

A mm	A ₁ mm	B mm	C mm	D mm	E mm	F mm	G mm	L _{max} mm	Art. nr. Systembakker
80	125	3 - 84	50	28	78	81	130	157	80 878 890 + 80 878 870
80	125	3 - 145	50	28	78	104	190	206	80 878 890 + 80 878 870
125	180	7 - 126	50	22	90	111,5	160	212	80 878 590 + 80 878 570
125	180	7 - 207	50	22	90	143,5	235	272	80 878 590 + 80 878 570
125	180	7 - 250	50	22	90	181	300	352	80 878 590 + 80 878 570
160	256	16 - 292	70	22	110	170	280	315	80 878 690 + 80 878 670
160	256	16 - 406	70	22	110	276	480	524	80 878 690 + 80 878 670

Med alubakker

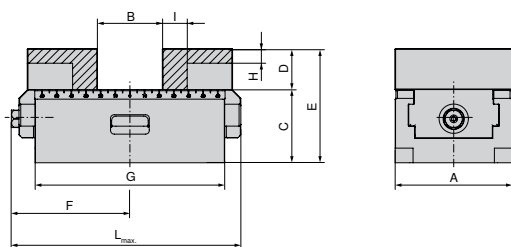

A mm	B mm	C mm	D mm	E mm	F mm	G mm	H mm	I mm	L _{max} mm	Art. nr. Systembakker
80	0 - 44	50	28	78	81	130	10	17	157	2 x 80 878 850
80	0 - 108	50	28	78	104	190	10	17	206	2 x 80 878 850
125	0 - 58	50	40	90	111,5	160	17	27	208	2 x 80 878 550
125	0 - 133	50	40	90	143,5	235	17	27	272	2 x 80 878 550
125	0 - 198	50	40	90	181	300	17	27	348	2 x 80 878 550
160	0 - 123	70	50	120	170	280	26	25	315	2 x 80 878 305
160	10 - 336	70	50	120	276	480	26	25	524	2 x 80 878 305

ZSG 4 dimensionstabel til de forskellige bakker

Med 5-akset bakker

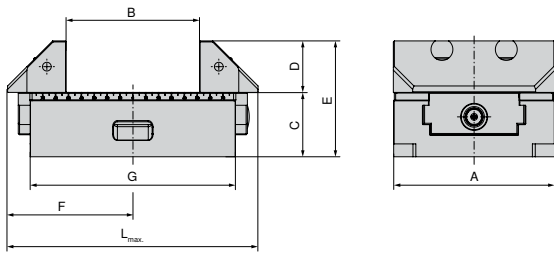

A mm	B mm	C mm	D mm	E mm	F mm	G mm	L _{max.} mm	Art. nr. Systembakker
125	22 - 102	50	40	90	115,5	160	208	2 x 80 878 625
125	22 - 165	50	40	90	143,5	235	272	2 x 80 878 625
125	22 - 242	50	40	90	181	300	348	2 x 80 878 625
160	15 - 140	70	50	120	170	280	315	2 x 80 878 660
160	28 - 354	70	50	120	276	480	524	2 x 80 878 660

Med 5-akset bakker, grip 3 mm, bredde 65 mm

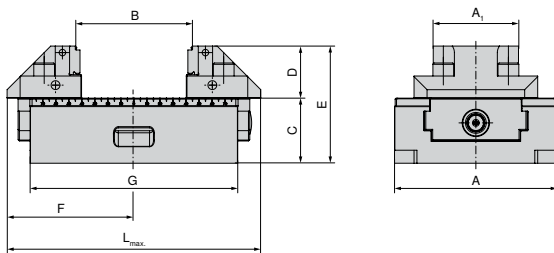

A mm	A ₁ mm	B mm	C mm	D mm	E mm	F mm	G mm	L _{max.} mm	Art. nr. Systembakker
125	65	8 - 87	50	40	90	115,5	160	208	2 x 80 878 665
125	65	8 - 162	50	40	90	143,5	235	272	2 x 80 878 665
125	65	8 - 227	50	40	90	181	300	348	2 x 80 878 665

Med vendebakker, grip 3 mm, bredde 65 mm

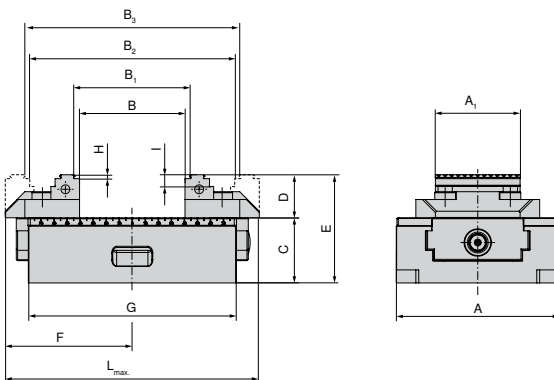

A mm	A ₁ mm	B mm	B ₁ mm	B ₂ mm	B ₃ mm	C mm	D mm	E mm	F mm	G mm	H mm	I mm	L _{max.} mm	Art. nr. Systembakker
125	65	0 - 80	8 - 87	77 - 156	84 - 163	50	33	83	111,5	160	3	9	208	2 x 80 878 51900
125	65	0 - 142	8 - 149	77 - 218	84 - 225	50	33	83	143,5	235	3	9	272	2 x 80 878 51900
125	65	0 - 220	8 - 227	77 - 296	84 - 303	50	33	83	181	300	3	9	348	2 x 80 878 51900

ZSG 4 dimensionstabel til de forskellige bakker

Med vendebakker, grip 3 mm

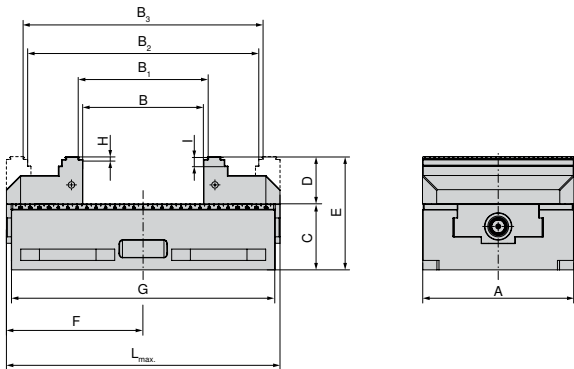

A mm	B mm	B ₁ mm	B ₂ mm	B ₃ mm	C mm	D mm	E mm	F mm	G mm	H mm	I mm	L _{max} mm	Art. nr. Systembakker
160	0 - 127	8 - 134	118 - 244	125 - 251	70	50	120	170	280	3	10	315	2 x 80 878 610
160	15 - 341	22 - 348	132 - 458	139 - 465	70	50	120	276	480	3	10	524	2 x 80 878 610

Med vendebakker, grip 3 mm, højde 40 mm

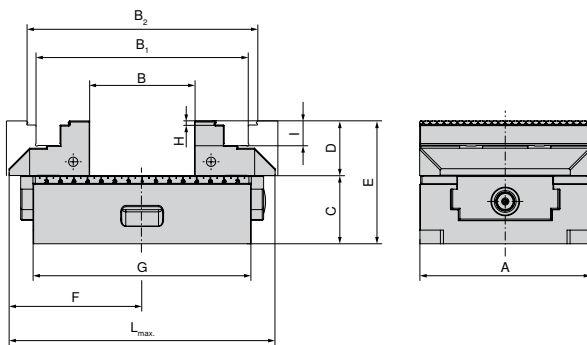

A mm	B mm	B ₁ mm	B ₂ mm	C mm	D mm	E mm	F mm	G mm	H mm	I mm	L _{max} mm	Art. nr. Systembakker
125	0 - 75	75 - 154	88 - 166	50	40	90	111,5	160	3	9	208	2 x 80 878 520
125	0 - 138	75 - 217	88 - 229	50	40	90	143,5	235	3	9	272	2 x 80 878 520
125	0 - 215	75 - 294	88 - 306	50	40	90	181	300	3	9	348	2 x 80 878 520

Med 6-fags bakesystem til bakkebredde 125 mm

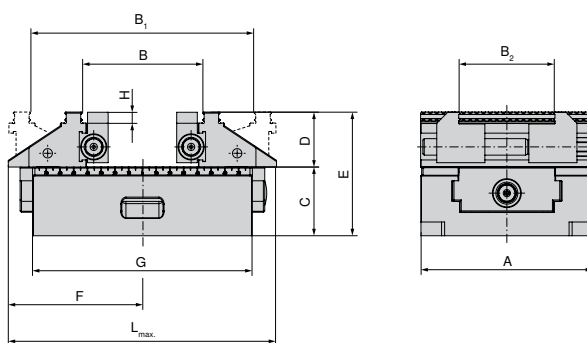

A mm	B mm	B ₁ mm	B ₂ mm	C mm	D mm	E mm	F mm	G mm	H mm	L _{max} mm	Art. nr. Systembakker
125	39 - 86	83 - 161	37 - 101	50	40	90	111,5	160	8	209	80 878 525
125	39 - 149	83 - 224	37 - 101	50	40	90	143,5	235	8	272	80 878 525
125	39 - 226	83 - 301	37 - 101	50	40	90	181	300	8	349	80 878 525

ZSG 4 dimensionstabel til de forskellige bakker

Med mellembakke, grip 3 mm (højde 28 mm / 33 mm) til bakkebredde 125 mm

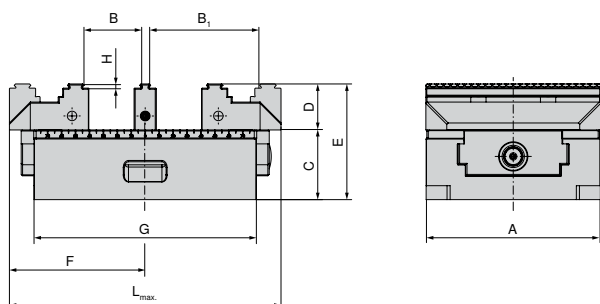

A mm	B mm	B ₁ mm	C mm	D mm	E mm	F mm	G mm	H mm	L _{max.} mm	Art. nr. Systembakker
80	8 - 28	37 - 57	50	28	78	81	130	3	157	2 x 80 878 810 + 80 878 31200
80	14 - 22	31 - 51	50	28	78	81	130	3	157	2 x 80 878 810 + 80 878 33400
80	8 - 58	37 - 87	50	28	78	104	190	3	206	2 x 80 878 810 + 80 878 31200
80	14 - 52	31 - 81	50	28	78	104	190	3	206	2 x 80 878 810 + 80 878 33400
125	9 - 40	47 - 78	50	33	83	111,5	160	3	208	2 x 80 878 510 + 80 878 31300
125	15 - 34	41 - 72	50	33	83	111,5	160	3	208	2 x 80 878 510 + 80 878 33500
125	9 - 72	47 - 110	50	33	83	143,5	235	3	272	2 x 80 878 510 + 80 878 31300
125	15 - 66	41 - 104	50	33	83	143,5	235	3	272	2 x 80 878 510 + 80 878 33500
125	9 - 110	47 - 148	50	33	83	181	300	3	348	2 x 80 878 510 + 80 878 31300
125	15 - 104	41 - 142	50	33	83	181	300	3	348	2 x 80 878 510 + 80 878 33500

Med topbakke, bevægelig – vandret og lodret prisme

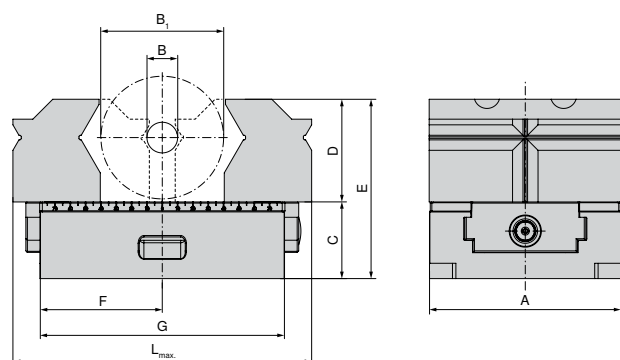

A mm	B mm	B ₁ mm	C mm	D mm	E mm	F mm	G mm	L _{max.} mm	Art. nr. Systembakker
80	10 - 28	20 - 60	50	52	102	81	130	157	2 x 80 878 31800
80	10 - 28	20 - 60	50	52	102	104	190	206	2 x 80 878 31800
125	10 - 28	26 - 80	50	67	117	111,5	160	200	2 x 80 878 31900
125	10 - 28	26 - 80	50	67	117	143,5	235	272	2 x 80 878 31900
125	10 - 28	26 - 80	50	67	117	181	300	348	2 x 80 878 31900

ZSG 4 dimensionstabel til de forskellige bakker

Med topbakke, bevægelig – vandret prisme

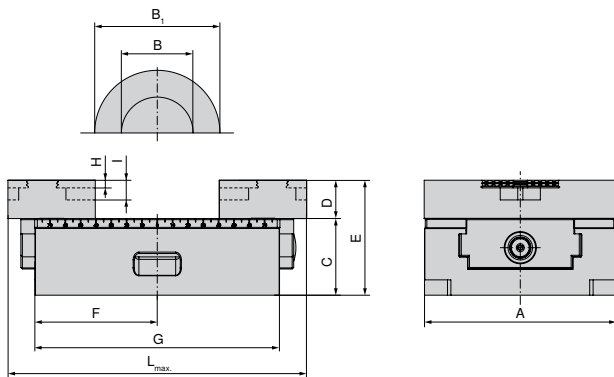

A mm	B mm	B ₁ mm	C mm	D mm	E mm	F mm	G mm	H mm	I mm	L _{max} mm	Art. nr. Systembakker
80	8 - 55	15 - 76	50	25	75	81	130	5	13	157	2 x 80 878 34000
80	8 - 55	15 - 76	50	25	75	104	190	5	13	206	2 x 80 878 34000
125	14 - 102	25 - 112	50	25	75	111,5	160	5	13	200	2 x 80 878 34100
125	14 - 124	25 - 165	50	25	75	143,5	235	5	13	272	2 x 80 878 34100
125	14 - 124	25 - 165	50	25	75	181	300	5	13	348	2 x 80 878 34100
160	22 - 158	32 - 170	70	30	100	145	280	5	13	290	2 x 80 878 34200
160	22 - 158	32 - 170	70	30	100	273	480	5	13	521	2 x 80 878 34200

Oversigt systembakker

5-akset bakke, bevægelig

▲ Pris pr. stk.

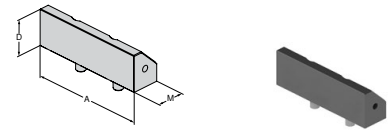

Til skruestikbredde	A	A ₁	D	D ₁	D ₂	E	M	M ₁	M ₂	DKK	Y4	NCG	H5G / -S / -Z	X5G-Z / -S	ESG 4	ESG 5	HDG 2	ZSG 4	ZSG mini	DSG 4	Verso	HSG	
125	125		40				45,5			1.683,00									●				
160	160		50				73			2.072,00									●				

5-akset bakke, grip 3 mm, bredde 65 mm, bevægelig

▲ Pris pr. stk.

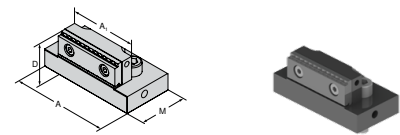

Til skruestikbredde	A	A ₁	D	D ₁	D ₂	E	M	M ₁	M ₂	DKK	Y4	NCG	H5G / -S / -Z	X5G-Z / -S	ESG 4	ESG 5	HDG 2	ZSG 4	ZSG mini	DSG 4	Verso	HSG	
125	95	65,5	40				57			1.945,00									●				

5-akset vendebakke, grip 3 mm, bredde 65 mm, bevægelig

▲ Dobbeltsidet griptrin

▲ Pris pr. stk.

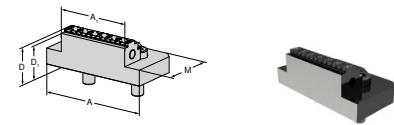

Til skruestikbredde	A	A ₁	D	D ₁	D ₂	E	M	M ₁	M ₂	DKK	Y4	NCG	H5G / -S / -Z	X5G-Z / -S	ESG 4	ESG 5	HDG 2	ZSG 4	ZSG mini	DSG 4	Verso	HSG	
125	95	65	33	30			57			1.466,00									●				

Vendebakke, grip 3 mm, bredde 40 mm, bevægelig

▲ Pris pr. stk.

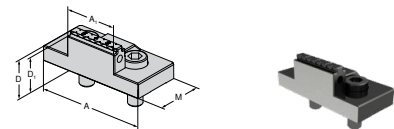

Til skruestikbredde	A	A ₁	D	D ₁	D ₂	E	M	M ₁	M ₂	DKK	Y4	NCG	H5G / -S / -Z	X5G-Z / -S	ESG 4	ESG 5	HDG 2	ZSG 4	ZSG mini	DSG 4	Verso	HSG	
80	80	40	28	25			40			1.346,00					●			●					

Vendebakke, grip 3 mm, højde 40 mm, bevægelig

▲ Pris pr. stk.

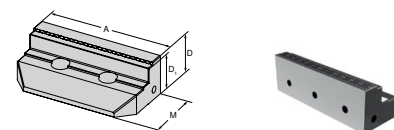

Til skruestikbredde	A	A ₁	D	D ₁	D ₂	E	M	M ₁	M ₂	DKK	Y4	NCG	H5G / -S / -Z	X5G-Z / -S	ESG 4	ESG 5	HDG 2	ZSG 4	ZSG mini	DSG 4	Verso	HSG	
125	125		40	37			59			2.109,00									●				

Oversigt systembakker

Vendebakke, grip 3 mm, bevægelig

▲ Pris pr. stk.

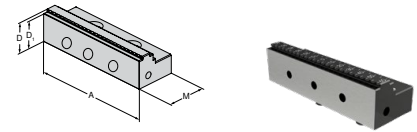

Til skruestikbredde	A	A ₁	D	D ₁	D ₂	E	M	M ₁	M ₂	DKK	Y4	NCG	H5G / -S / -Z	X5G-Z / -S	ESG 4	ESG 5	HDC 2	ZSG 4	ZSG mini	DSG 4	Verso	HSG	
80	80		28	25			40			1.010,00	80 878 810				●	●		●		●			
125	125		33	30			57			1.129,00	80 878 510					●		●					
160	160		50	47			81			3.022,00	80 878 610				●		●	●					

Vendebakke, grip 5 mm, bevægelig

▲ Pris pr. stk.

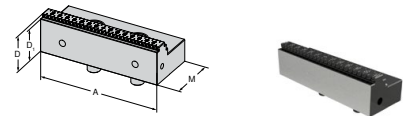

Til skruestikbredde	A	A ₁	D	D ₁	D ₂	E	M	M ₁	M ₂	DKK	Y4	NCG	H5G / -S / -Z	X5G-Z / -S	ESG 4	ESG 5	HDC 2	ZSG 4	ZSG mini	DSG 4	Verso	HSG	
80	80		28	23			41			1.197,00	80 878 81400				●			●		●			
125	125		33	28			57			1.324,00	80 878 51400							●					
160	160		50	45			81			3.022,00	80 878 34300				●		●	●					

Vendebakke, grip til aluminium og plast

▲ Pris pr. stk.

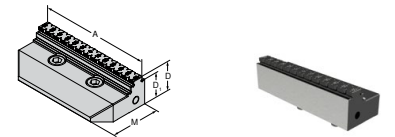

Til skruestikbredde	A	A ₁	D	D ₁	D ₂	E	M	M ₁	M ₂	DKK	Y4	NCG	H5G / -S / -Z	X5G-Z / -S	ESG 4	ESG 5	HDC 2	ZSG 4	ZSG mini	DSG 4	Verso	HSG	
80	80		28	23			40			1.429,00	80 878 81500							●					
125	125		33	28			57			1.571,00	80 878 51500							●					

Vendebakke, prægeprofil, bevægelig

▲ Pris pr. stk.

▲ Passer til prægeprofil LANG

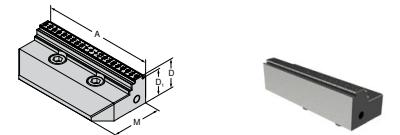

Til skruestikbredde	A	A ₁	D	D ₁	D ₂	E	M	M ₁	M ₂	DKK	Y4	NCG	H5G / -S / -Z	X5G-Z / -S	ESG 4	ESG 5	HDC 2	ZSG 4	ZSG mini	DSG 4	Verso	HSG	
80	80		28	25			40			1.272,00	80 878 81800							●					
125	125		33	30			57			1.743,00	80 878 51800							●					

Oversigt systembakker

Vendebakke, hårdmetal, grip 3 mm, bevægelig

▲ Pris pr. stk.

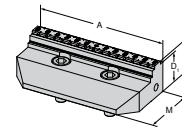

Til skruestikbredde	A	A ₁	D	D ₁	D ₂	E	M	M ₁	M ₂	DKK	Y4	NCG	H5G / -S / -Z	X5G-Z / -S	ESG 4	ESG 5	HDG 2	ZSG 4	ZSG mini	DSG 4	Verso	HSG	
80	80		28	25			40			1.810,00	80 878 81600								●				
125	125		33	30			57			2.558,00	80 878 51600								●				
160	160		50	47			81			4.017,00	80 878 31700								●				

Vendebakke, hårdmetal, grip 5 mm, bevægelig

▲ Pris pr. stk.

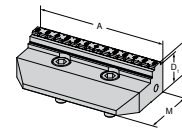

Til skruestikbredde	A	A ₁	D	D ₁	D ₂	E	M	M ₁	M ₂	DKK	Y4	NCG	H5G / -S / -Z	X5G-Z / -S	ESG 4	ESG 5	HDG 2	ZSG 4	ZSG mini	DSG 4	Verso	HSG	
80	80		28	23			40			1.810,00	80 878 81700								●				
125	125		33	28			57			2.558,00	80 878 51700								●				

Vendebakke, hårdmetal, grip 3 mm, bredde 40 mm, bevægelig

▲ Pris pr. stk.

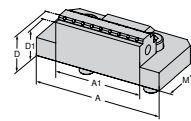

Til skruestikbredde	A	A ₁	D	D ₁	D ₂	E	M	M ₁	M ₂	DKK	Y4	NCG	H5G / -S / -Z	X5G-Z / -S	ESG 4	ESG 5	HDG 2	ZSG 4	ZSG mini	DSG 4	Verso	HSG	
80	80	40	28	25			40			1.750,00	80 878 33200								●				

Vendebakke, hårdmetal, grip 3 mm, bredde 65 mm, bevægelig

▲ Pris pr. stk.

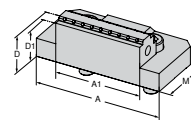

Til skruestikbredde	A	A ₁	D	D ₁	D ₂	E	M	M ₁	M ₂	DKK	Y4	NCG	H5G / -S / -Z	X5G-Z / -S	ESG 4	ESG 5	HDG 2	ZSG 4	ZSG mini	DSG 4	Verso	HSG	
125	125	65	33	30			57			2.424,00	80 878 33300								●				

Vendebakke, glat, bevægelig

▲ Pris pr. stk.

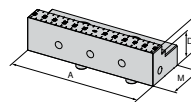

Til skruestikbredde	A	A ₁	D	D ₁	D ₂	E	M	M ₁	M ₂	DKK	Y4	NCG	H5G / -S / -Z	X5G-Z / -S	ESG 4	ESG 5	HDG 2	ZSG 4	ZSG mini	DSG 4	Verso	HSG	
80	80		28	20			40			1.459,00	80 878 34700				●			●					
125	125		33	25			57			2.827,00	80 878 34600				●			●					

Oversigt systembakker

Trinbakke, glat, bevægelig

▲ Pris pr. stk.

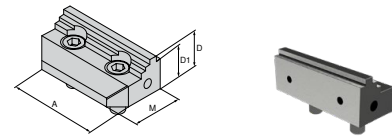

Til skruestikbredde	A	A ₁	D	D ₁	D ₂	E	M	M ₁	M ₂	DKK	Y4	NCG	H5G / -S / -Z	X5G-Z / -S	ESG 4	ESG 5	HDG 2	ZSG 4	ZSG mini	DSG 4	Verso	HSG	
80	80		28	24			40			1.848,00									●				
125	125		33	27			57			2.596,00									●				

Centerbakke, grip 3 mm, smal

▲ Pris pr. stk.

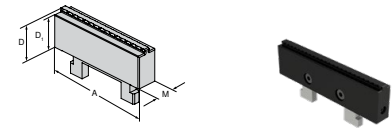

Til skruestikbredde	A	A ₁	D	D ₁	D ₂	E	M	M ₁	M ₂	DKK	Y4	NCG	H5G / -S / -Z	X5G-Z / -S	ESG 4	ESG 5	HDG 2	ZSG 4	ZSG mini	DSG 4	Verso	HSG	
80	80		28	25			16			823,00									●				
125	125		33	30			16			1.159,00									●				

Centerbakke, grip 3 mm, bred

▲ Pris pr. stk.

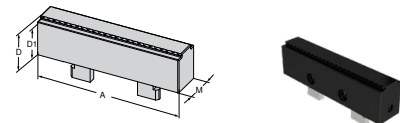

Til skruestikbredde	A	A ₁	D	D ₁	D ₂	E	M	M ₁	M ₂	DKK	Y4	NCG	H5G / -S / -Z	X5G-Z / -S	ESG 4	ESG 5	HDG 2	ZSG 4	ZSG mini	DSG 4	Verso	HSG	
80	80		28	25			24			823,00									●				
125	125		33	30			26			1.159,00									●				

Topbakke, bevægelig

▲ Med vandret og lodret prisme

▲ Pris pr. stk.

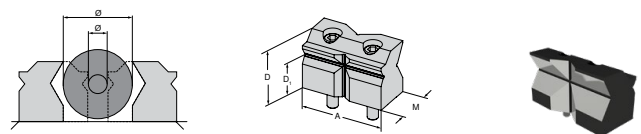

Ø til spænddiameter	A	A ₁	D	D ₁	D ₂	E	M	M ₁	M ₂	DKK	Y4	NCG	H5G / -S / -Z	X5G-Z / -S	ESG 4	ESG 5	HDG 2	ZSG 4	ZSG mini	DSG 4	Verso	HSG	
10 - 60	80		52	32			38,5			2.386,00									●				
10 - 80	125		67	42			57			3.635,00									●				

Oversigt systembakker

Topbakke, bevægelig

- ▲ Med vandret prisme
- ▲ Pris pr. stk.

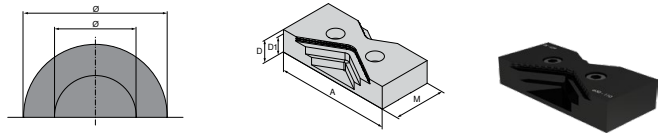

Ø til spænddiameter	A	A ₁	D	D ₁	D ₂	E	M	M ₁	M ₂	DKK	Y4	NCG	H5G / -S / -Z	X5G-Z / -S	ESG 4	ESG 5	HDG 2	ZSG 4	ZSG mini	DSG 4	Verso	HSG	
15 - 75	80		25	20			40			1.279,00	80 878 34000												
25 - 110	125		25	20			57			1.646,00	80 878 34100							●					
30 - 170	160		30	25			81			2.132,00	80 878 34200							●					

Kombibakke, bevægelig

- ▲ Pris pr. stk.

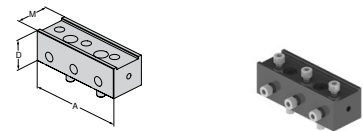

Til skruestikbredde	A	A ₁	D	D ₁	D ₂	E	M	M ₁	M ₂	DKK	Y4	NCG	H5G / -S / -Z	X5G-Z / -S	ESG 4	ESG 5	HDG 2	ZSG 4	ZSG mini	DSG 4	Verso	HSG	
125	125		40				45,5			1.294,00	80 878 530							●					

Bakke, grip, VS

- ▲ Pris pr. stk.
- ▲ VS = øget spændområde

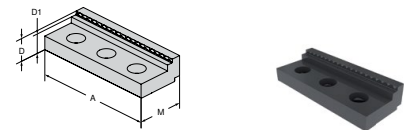

Til skruestikbredde	A	A ₁	D	D ₁	D ₂	E	M	M ₁	M ₂	DKK	Y4	NCG	H5G / -S / -Z	X5G-Z / -S	ESG 4	ESG 5	HDG 2	ZSG 4	ZSG mini	DSG 4	Verso	HSG	
125	125		22	17			45			743,00	80 892 245							●					

Bakker, glat VS, WC-belagt

- ▲ Øget spændområde til færdigbearbejdning og 2-sidet
- ▲ Pris pr. stk.

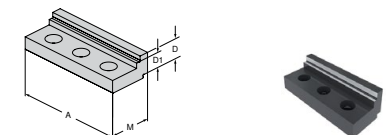

Til skruestikbredde	A	A ₁	D	D ₁	D ₂	E	M	M ₁	M ₂	DKK	Y4	NCG	H5G / -S / -Z	X5G-Z / -S	ESG 4	ESG 5	HDG 2	ZSG 4	ZSG mini	DSG 4	Verso	HSG	
125	125		19	14			45			1.788,00	80 892 240							●					

Alubakke

- ▲ Til fremstilling af formbakker
- ▲ Pris pr. stk.

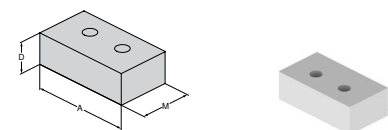

Til skruestikbredde	A	A ₁	D	D ₁	D ₂	E	M	M ₁	M ₂	DKK	Y4	NCG	H5G / -S / -Z	X5G-Z / -S	ESG 4	ESG 5	HDG 2	ZSG 4	ZSG mini	DSG 4	Verso	HSG	
80	80		28				48			646,00	80 878 850				●	●		●					
125	125		40				68			735,00	80 878 550				●	●		●		●			
160	160		50				85			928,00	80 878 305				●	●		●					

Oversigt systembakker

Blød bakke, stål, bevægelig

- ▲ Materiale: 16MnCr5
- ▲ Til fremstilling af formbakker
- ▲ Pris pr. stk.

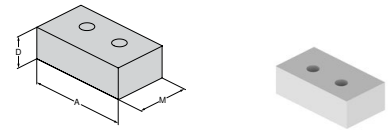

Til skruestikbredde	A	A ₁	D	D ₁	D ₂	E	M	M ₁	M ₂	DKK	Y4	NCG	H5G / -S / -Z	X5G-Z / -S	ESG 4	ESG 5	HDG 2	ZSG 4	ZSG mini	DSG 4	Verso	HSG	
80	80		28				48			666,00					●	●		●					
125	125		40				68			838,00					●	●		●					

Pendulbakke, bevægelig

- ▲ Rummer 6 gange vendbare bakker
- ▲ Pris pr. stk.

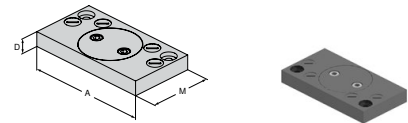

Til skruestikbredde	A	A ₁	D	D ₁	D ₂	E	M	M ₁	M ₂	DKK	Y4	NCG	H5G / -S / -Z	X5G-Z / -S	ESG 4	ESG 5	HDG 2	ZSG 4	ZSG mini	DSG 4	Verso	HSG	
80	125		19				76			3.059,00					●			●					
125	180		22				95			3.186,00					●			●					
160	256		22				170			5.430,00					●			●					

Adapterbakke

- ▲ Rummer 6 gange vendbare bakker
- ▲ Pris pr. stk.

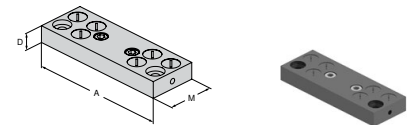

Til skruestikbredde	A	A ₁	D	D ₁	D ₂	E	M	M ₁	M ₂	DKK	Y4	NCG	H5G / -S / -Z	X5G-Z / -S	ESG 4	ESG 5	HDG 2	ZSG 4	ZSG mini	DSG 4	Verso	HSG	
80	125		19				39			2.169,00								●					
125	180		22				62			2.588,00								●					
160	256		22				125			3.620,00								●					

6-fags vendebakke

- ▲ 1 = Glat, Wolfram-Carbide belagt
- ▲ 2 = Grip med trin 3 mm
- ▲ 3 = Grip med trin 8 mm
- ▲ 4 = Grip med trin 18 mm
- ▲ 5 = Grip rund med trin 8 mm
- ▲ 6 = Grip rund
- ▲ M_{max} = 60 Nm
- ▲ Inkl. fastspændingsbolte

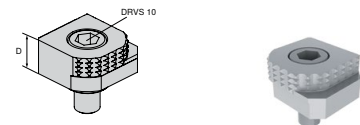

Til skruestikbredde	A	A ₁	D	D ₁	D ₂	E	M	M ₁	M ₂	DKK	Y4	NCG	H5G / -S / -Z	X5G-Z / -S	ESG 4	ESG 5	HDG 2	ZSG 4	ZSG mini	DSG 4	Verso	HSG	
			18							603,00			●	●	●			●		●	●		
													●	●	●			●		●	●		

Oversigt systembakker

6-fags vendebakke, Carbide grip

- ▲ 1 = Glat
- ▲ 2 = Carbide grip
- ▲ 3 = Carbide grip med trin 3 mm
- ▲ 4 = Carbide grip med trin 8 mm
- ▲ 5 = Carbide grip rund med trin 8 mm
- ▲ 6 = Carbide grip rund
- ▲ Inkl. fastspændingsbolte

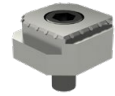
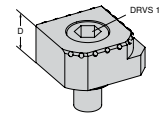

Til skruestikbredde	A	A ₁	D	D ₁	D ₂	E	M	M ₁	M ₂	DKK	Y4	NOG	H5G / -S / -Z	X5G-Z / -S	ESG 4	ESG 5	H5G 2	ZSG 4	ZSG mini	DSG 4	Verso	H5G
			18							875,00	80 890 35300	●	●	●	●			●		●	●	

6-fags bakesystem til bakkebredde 125 mm

Leveringsomfang:

2 systembakker med 2 par tværbakker i T-not-skinne inkl. fastspændingsbolte

ZSG
4

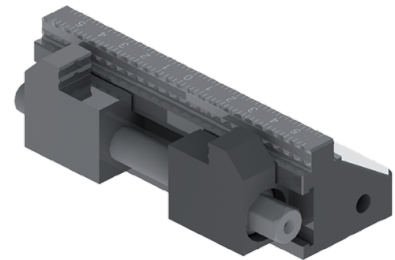
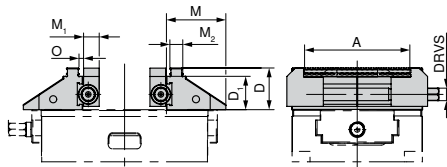

Til bredde	A	D	D ₁	M	M ₁	M ₂	O	DRVS	WT	80 878 ...
mm	mm	mm	mm	mm	mm	mm	mm	mm	kg	DKK
125	37 - 101	40	32	57	15	12,4	3,3	12	3,8	Y4
										12.866,00
										525

ZSG mini



Centrer skruestik til små emner

ZSG mini i mekanisk udgave med høj spændkraft og Hurtigskift-bakker. Velegnet til bearbejdning af råemner og færdigbearbejdning af emner, multiopspænding og automatisering.

Dine fordele:

- ▲ Hurtigskift-bakker uden værktøj
- ▲ Kompakt og præcis
- ▲ God adgang fra alle sider
- ▲ Bakkebredder kan udskiftes (45 mm og 70 mm)
- ▲ Høj spændkraft og stort spændområde
- ▲ Spændesystem til automation
- ▲ Rustfri og hærdet grundkrop



Opspænding/justering:



Opspænding med to M6-skruer ovenfra i gennem grundkroppen.



Opspænding med to M6-skruer ovenfra gennem grundkroppen. Justering via $\text{Ø } 12^{\text{H7}}$ præcisionshuller.



Begge varianter er forberedt med monteringshuller til LANG nulpunkt spændesystemet Quick Point 52 x 52.

Spændkraft:

Tilspændingsmoment / spændkraft ZSG mini

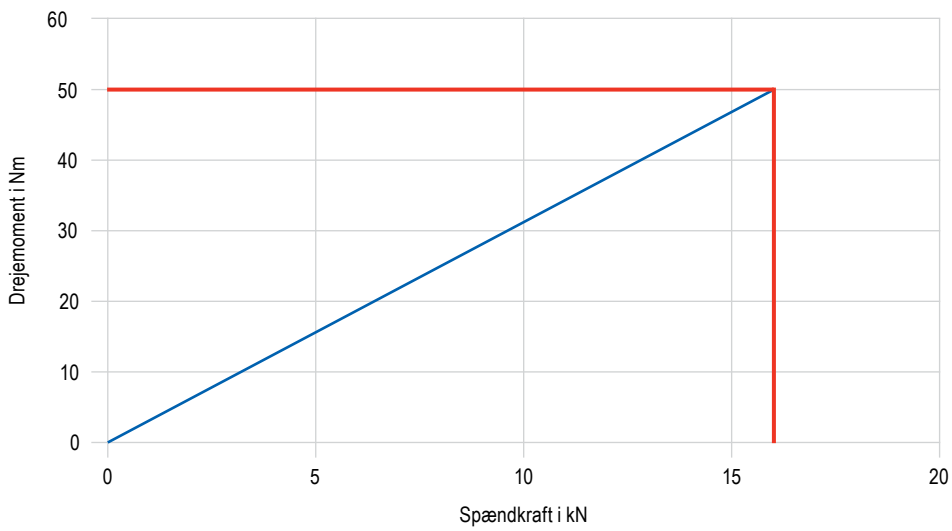

CentriClamp – ZSG mini

- ▲ Centrisk skruestik til små emner
- ▲ Uden systembakker
- ▲ Hurtigskift-bakker uden værktøj
- ▲ Kompakt og præcis
- ▲ Bedste tilgængelighed fra alle sider
- ▲ Bakkebredder kan udskiftes (45 mm og 70 mm)
- ▲ Rustfri og hærdet grundkrop

Leveringsomfang:

ZSG mini grundkrop med spindel

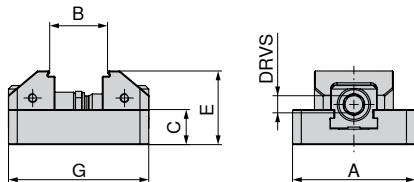

NEW

80 912 ...

A	B	C	E	G	MXC	DRVS	WT
mm	mm	mm	mm	mm	kN	mm	kg
70	7 - 57	20	42	80	16	11	0,9
70	7 - 77	20	42	100	16	11	1,1

DKK
Y4

3.142,00 07000
3.560,00 07100

Skruestikguide

Dimensioner	94	Dimensionstabeller til de forskellige bakker	95-97
Systemtilbehør	98-100	MNG-/PNG-nulpunkt-spændesystem	134-163
Alment tilbehør	164-183		

ZSG mini dimensioner

Grundkrop bredde 70 mm

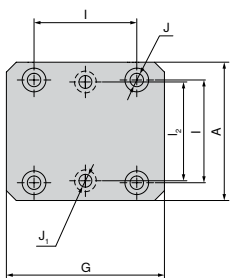

A	J ₁	J _{H7}	l _{2 ±0,01}	l ±0,01	G
mm	mm	mm	mm	mm	mm
70	6,5	12	50	52	80
70	6,5	12	50	52	100

ZSG mini – dimensionstabel til de forskellige bakker

Med hurtigskift-bakke, grip 3 mm

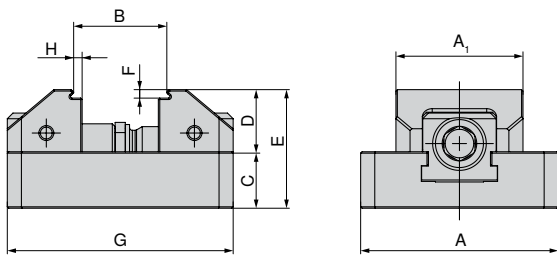

A mm	A ₁ mm	B mm	C mm	D mm	E mm	F mm	G mm	H mm	Art. nr. Systembakker
70	45	7-33	20	22	42	3	80	3	2 x 80 912 30100
70	70	7-33	20	22	42	3	80	3	2 x 80 912 30200
70	45	7-53	20	22	42	3	100	3	2 x 80 912 30100
70	70	7-53	20	22	42	3	100	3	2 x 80 912 30200

Med hurtigskift-bakke, glatte trin 5 mm

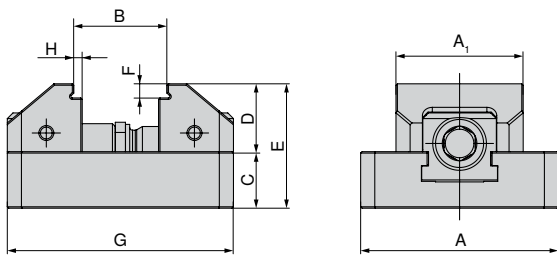

A mm	A ₁ mm	B mm	C mm	D mm	E mm	F mm	G mm	H mm	Art. nr. Systembakker
70	45	7-33	20	24	44	5	80	3	2 x 80 912 30300
70	70	7-33	20	24	44	5	80	3	2 x 80 912 30400
70	45	7-53	20	24	44	5	100	3	2 x 80 912 30300
70	70	7-53	20	24	44	5	100	3	2 x 80 912 30400

Med hurtigskift-bakke, blød, stål

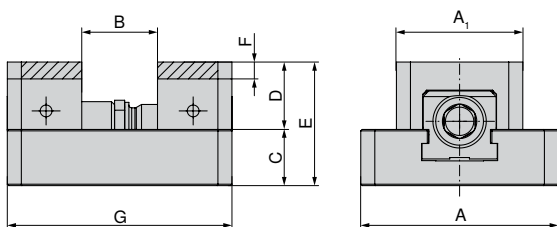

A mm	A ₁ mm	B mm	C mm	D mm	E mm	F mm	G mm	Art. nr. Systembakker
70	45	0-26	20	24	44	6	80	2 x 80 912 31000
70	70	0-26	20	24	44	6	80	2 x 80 912 31100
70	45	0-46	20	24	44	6	80	2 x 80 912 31000
70	70	0-46	20	24	44	6	80	2 x 80 912 31100

ZSG mini – dimensionstabel til de forskellige bakker

Med hurtigskift-bakke, prægeprofil

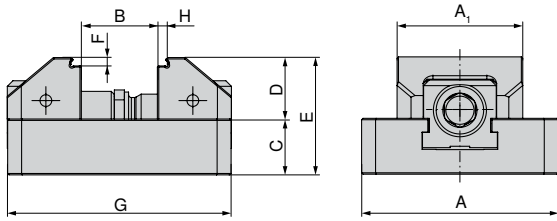

A mm	A ₁ mm	B mm	C mm	D mm	E mm	F mm	G mm	H mm	Art. nr. Systembakker
70	45	7 - 32	20	22	44	3	80	3	2 x 80 912 31200
70	70	7 - 32	20	22	44	3	80	3	2 x 80 912 31300
70	45	7 - 52	20	22	44	3	100	3	2 x 80 912 31200
70	70	7 - 52	20	22	44	3	100	3	2 x 80 912 31300

Med hurtigskift-bakke, prægeprofil, VS

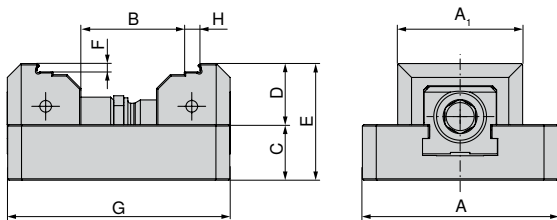

A mm	A ₁ mm	B mm	C mm	D mm	E mm	F mm	G mm	H mm	Art. nr. Systembakker
70	45	31 - 56	20	22	44	3	80	5	2 x 80 912 31400
70	70	31 - 56	20	22	44	3	80	5	2 x 80 912 31500
70	45	31 - 76	20	22	44	3	100	5	2 x 80 912 31400
70	70	31 - 76	20	22	44	3	100	5	2 x 80 912 31500

ZSG mini – dimensionstabel til de forskellige bakker

Med hurtigskift-bakke, VS, grip 3 mm

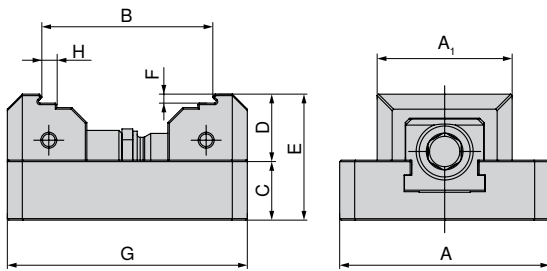

A mm	A ₁ mm	B mm	C mm	D mm	E mm	F mm	G mm	H mm	Art. nr. Systembakker
70	45	31 - 57	20	22	42	3	80	5	2 x 80 912 30500
70	70	31 - 57	20	22	42	3	80	5	2 x 80 912 30600
70	45	31 - 77	20	22	42	3	100	5	2 x 80 912 30500
70	70	31 - 77	20	22	42	3	100	5	2 x 80 912 30600

Med hurtigskift-bakke, VS, glat 5 mm

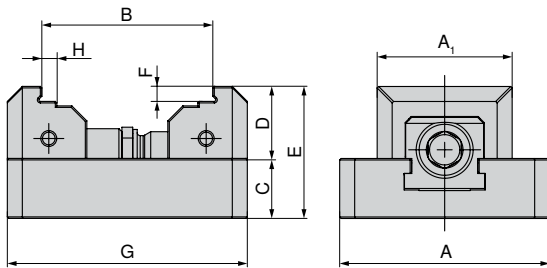

A mm	A ₁ mm	B mm	C mm	D mm	E mm	F mm	G mm	H mm	Art. nr. Systembakker
70	45	31 - 56	20	24	44	5	80	5	2 x 80 912 30700
70	70	31 - 56	20	24	44	5	80	5	2 x 80 912 30800
70	45	31 - 76	20	24	44	5	100	5	2 x 80 912 30700
70	70	31 - 76	20	24	44	5	100	5	2 x 80 912 30800

Oversigt systembakker

Hurtigskift-bakke, grip 3 mm

▲ Pris pr. stk.

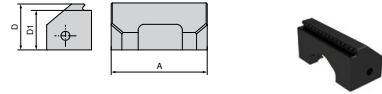

Til skruestikbredde	A	A ₁	D	D ₁	D ₂	E	M	M ₁	M ₂	DKK	Y4	NCG	H5G / -S / -Z	X5G-Z / -S	ESG 4	ESG 5	HDG 2	ZSG 4	ZSG mini	DSG 4	Verso	HSG	
70	45		22	19						380,00										●			
70	70		22	19						500,00										●			

Hurtigskift-bakke, glat 5 mm

▲ Pris pr. stk.

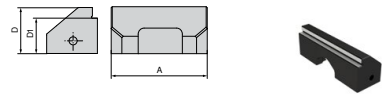

Til skruestikbredde	A	A ₁	D	D ₁	D ₂	E	M	M ₁	M ₂	DKK	Y4	NCG	H5G / -S / -Z	X5G-Z / -S	ESG 4	ESG 5	HDG 2	ZSG 4	ZSG mini	DSG 4	Verso	HSG	
70	45		24	19						460,00										●			
70	70		24	19						582,00										●			

Hurtigskift-bakke, VS, grip 3 mm

▲ Pris pr. stk.

▲ VS = øget spændområde

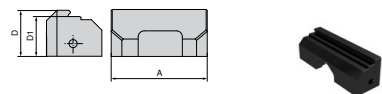

Til skruestikbredde	A	A ₁	D	D ₁	D ₂	E	M	M ₁	M ₂	DKK	Y4	NCG	H5G / -S / -Z	X5G-Z / -S	ESG 4	ESG 5	HDG 2	ZSG 4	ZSG mini	DSG 4	Verso	HSG	
70	45		22	19						380,00										●			
70	70		22	19						500,00										●			

Hurtigskift-bakke, VS, glat 5 mm

▲ Pris pr. stk.

▲ VS = øget spændområde

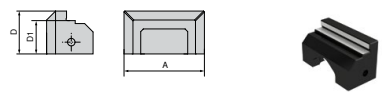

Til skruestikbredde	A	A ₁	D	D ₁	D ₂	E	M	M ₁	M ₂	DKK	Y4	NCG	H5G / -S / -Z	X5G-Z / -S	ESG 4	ESG 5	HDG 2	ZSG 4	ZSG mini	DSG 4	Verso	HSG	
70	45		24	19						460,00										●			
70	70		24	19						582,00										●			

Oversigt systembakker

Hurtigskift-bakke, blød, stål

- ▲ Materiale: 15NiCr13
- ▲ Pris pr. stk.

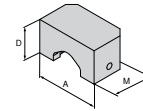

Til skruestikbredde	A	A ₁	D	D ₁	D ₂	E	M	M ₁	M ₂	DKK	Y4	NCG	H5G / -S / -Z	X5G-Z / -S	ESG 4	ESG 5	HDG 2	ZSG 4	ZSG mini	DSG 4	Verso	HSG	
70	45		24				26,5			307,00										●			
70	70		24				26,5			307,00										●			

Hurtigskift-bakke prægeprofil

- ▲ Pris pr. stk.
- ▲ Passer til prægeprofil LANG

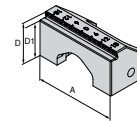

Til skruestikbredde	A	A ₁	D	D ₁	D ₂	E	M	M ₁	M ₂	DKK	Y4	NCG	H5G / -S / -Z	X5G-Z / -S	ESG 4	ESG 5	HDG 2	ZSG 4	ZSG mini	DSG 4	Verso	HSG	
70	45		22	19						582,00										●			
70	70		22	19						582,00										●			

Hurtigskift-bakke prægeprofil, VS

- ▲ Pris pr. stk.
- ▲ Passer til prægeprofil LANG
- ▲ VS = øget spændområde

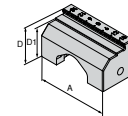

Til skruestikbredde	A	A ₁	D	D ₁	D ₂	E	M	M ₁	M ₂	DKK	Y4	NCG	H5G / -S / -Z	X5G-Z / -S	ESG 4	ESG 5	HDG 2	ZSG 4	ZSG mini	DSG 4	Verso	HSG	
70	45		22	19						711,00										●			
70	70		22	19						711,00										●			

Oversigt system-tilbehør

Unbraco top

▲ Passer til firkant 3/8"

ESG 4	ZSG 4
ZSG mini	DSG 4
MSG 2	



Firkant	DRVS mm	80 875 ...
3/8"	11	DKK Y4 136,00 11100



→ Side 176+180

Her finder du passende "magnetiske emnestop" og "momentnøgle"
(artikelnummer 80 892 23800 og 80 884 402).Umbrako med
indvendig sekskant

▲ Pris pr. stk.

ZSG mini



G	80 912 ...
M6x25	DKK Y4 9,00 50100

Cylinderstift

▲ Pris pr. stk.

ZSG mini

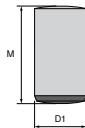

D ₁ m6 mm	M mm	80 912 ...
12	18	DKK Y4 17,00 50200

DSG 4

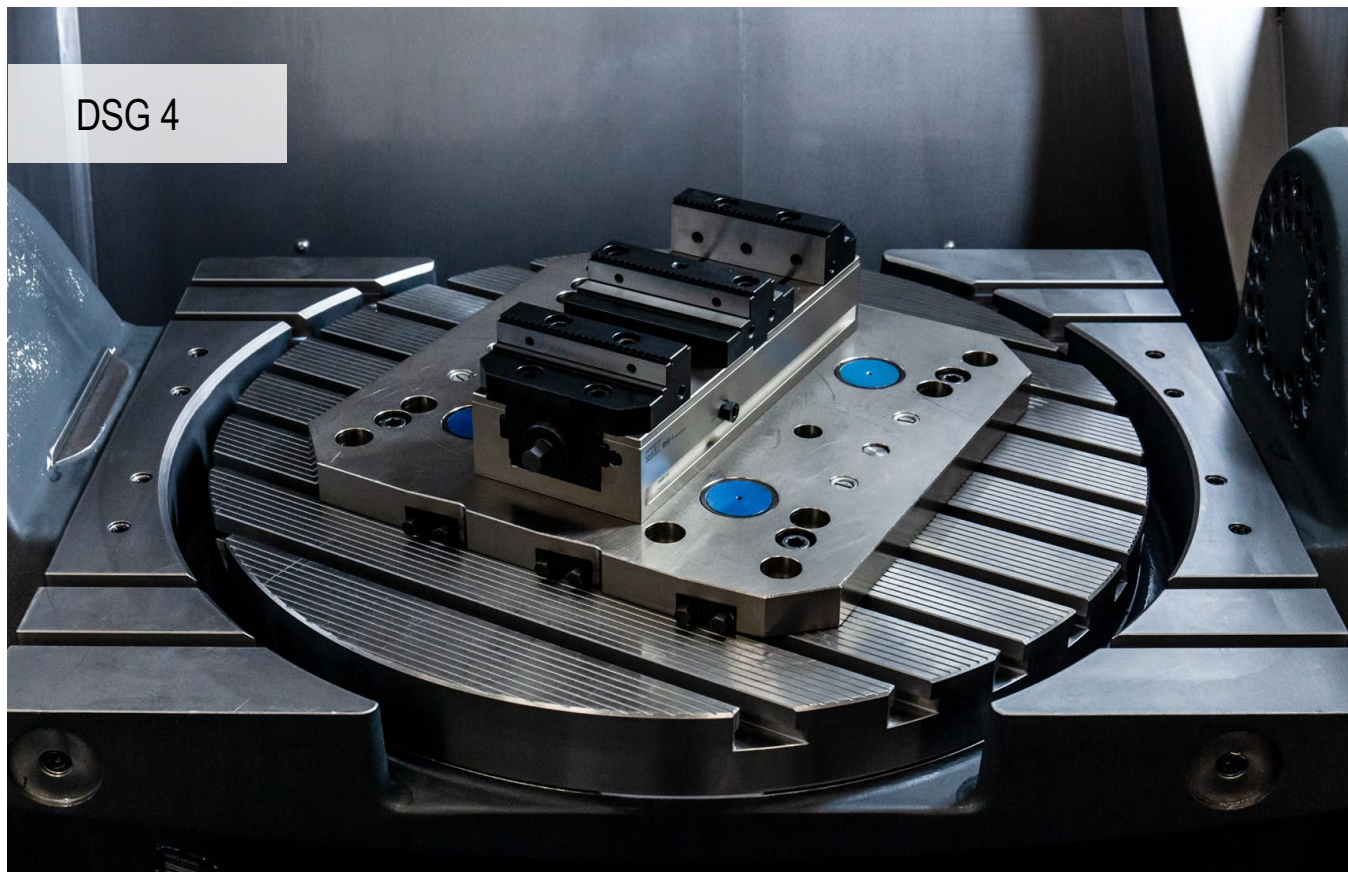

Høj nøjagtighed og høj effektivitet

Det brugervenlige DSG 4-spændesystem garanterer en konstant høj præcision og et bredt anvendelsesområde.

Dine fordele:

- ▲ Enkel og stabil tredjehåndsfunktion
- ▲ Nem og hurtig positionering på MNG-nulpunkt-spændesystem
- ▲ Høj spændkraft mellem 5-40 kN med lavt tilspændingsmoment
- ▲ Nemt og hurtigt skift af bakker med 2 skruer
- ▲ Omfattende modulopbygget bakke-program

Opspænding/justering:

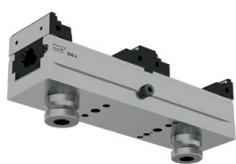

Fastgørelse med MNG-nulpunkt-spændesystem
(2-3 antræksbolte)

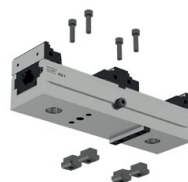

Fastgørelse via grundkroppen med fire M8-skruer

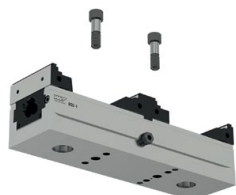

Fastgørelse via grundkroppen med to passkruer



Fastgørelse med 4-6 spændejern.

Spændkraft:

Tilspændingsmoment / spændkraft DSG 4 – 80 mm

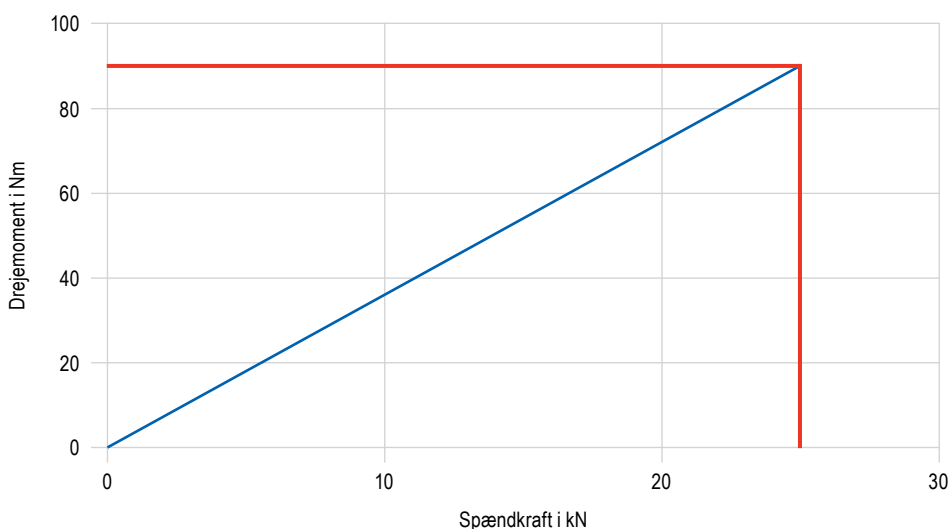

Tilspændingsmoment / spændkraft DSG 4 – 125 mm

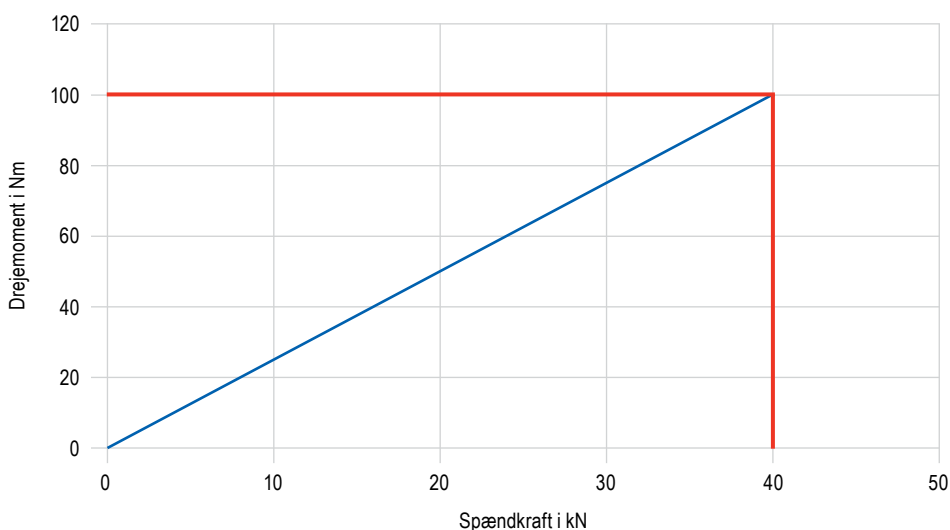

Tredjehånds-betjening

Tredjehånds betjeningsfunktionen på DSG 4 sikres via en forspænding af den bagerste skyder ved hjælp af trykfjedre.



Klemskruen er ikke fastspændt, men åben ca. 1/2 omgang A i siden er ikke spændt, men derimod kun drejet med ca. 1/2 omgang. Når skruestikken er maksimalt åben placeres og fastgøres de bevægelige bakker B og C i skyderens tilpassede riller D og E, afhængigt af emnestørrelse. Der kan opspændes 2 emner i forskellige størrelser.

Ombygning til enkel skruestik



Den bagerste skyder blokeres via gevindstiften med indvendig sekskant, og DSG 4 kan også bruges som skruestikker. **Vigtig information:** Ikke egnet til flere enkelte skruestikke ved siden af hinanden. Her anbefaler vi variationen med ekstra tværnot i grundkroppen og dertilhørende fastbakke.

PolyClamp – DSG 4

- ▲ Dobbelt skruestik uden bakker
- ▲ 100% indkapslet
- ▲ Hurtig på- og afmontering
- ▲ Fleksibel spændesystem

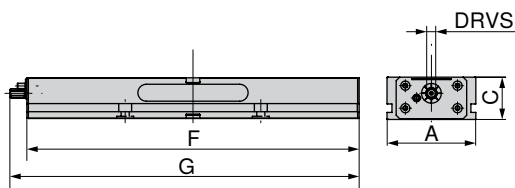
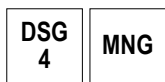

A	C	F	G	TQX	DRVS	MXC	WT	80 906 ...	
mm	mm	mm	mm	Nm	mm	kN	kg	DKK	
80	55	300	308	90	12	0 - 25	8	11.669,00	080
125	60	320	347	100	14	0 - 40	14	13.838,00	125
125	60	390	417	100	14	0 - 40	17	15.259,00	12700
125	60	460	487	100	14	0 - 40	20	17.204,00	12800
125	60	530	557	100	14	0 - 40	24	18.775,00	12900
125	60	600	627	100	14	0 - 40	27	20.346,00	13000
125	60	670	697	100	14	0 - 40	30	21.243,00	13100
125	60	740	767	100	14	0 - 40	34	22.066,00	126

Skruestikguide

Dimensionstabeller til de forskellige bakker	105-107	Systemtilbehør	108+110
Tredjehånds-betjening	102	Ombygning til enkel skruestik	103
MNG-/PNG-nulpunkt-spændesystem	134-163	Alment tilbehør	164-183

DSG 4 dimensioner

Grundkrop bredde 80 mm
og længde 300 mm

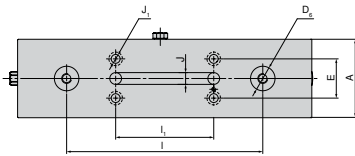

A	D ₆ H6	E ±0.015	I ±0.01	I ₁ ±0.01	J H7	J ₁
mm	mm	mm	mm	mm	mm	mm
80	25	40	200	100	12	9

Grundkrop bredde 125 mm
og længde 460 mm, 530 mm

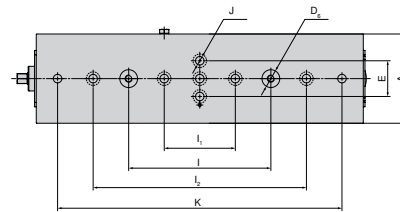

A	D ₆ H6	E ±0.015	I ±0.01	I ₁ ±0.01	I ₂ ±0.002	J H7	K ±0.002
mm	mm	mm	mm	mm	mm	mm	mm
125	25	50	200	100	300	12	400
125	25	50	200	100	300	12	500

Grundkrop bredde 125 mm
og længde 320 mm

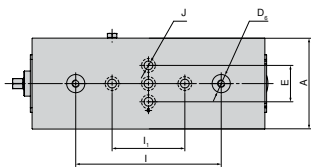

A	D ₆ H6	E ±0.015	I ±0.01	I ₁ ±0.01	J H7
mm	mm	mm	mm	mm	mm
125	25	50	200	100	12

Grundkrop bredde 125 mm
og længde 600 mm

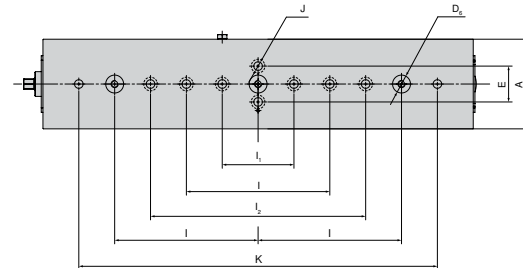

A	D ₆ H6	E ±0.015	I ±0.01	I ₁ ±0.01	I ₂ ±0.002	J H7	K ±0.002
mm	mm	mm	mm	mm	mm	mm	mm
125	25	50	200	100	300	12	500

Grundkrop bredde 125 mm
og længde 390 mm

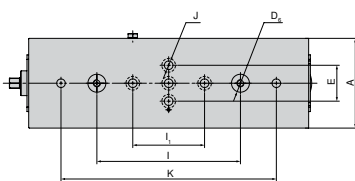

A	D ₆ H6	E ±0.015	I ±0.01	I ₁ ±0.01	J H7	K ±0.002
mm	mm	mm	mm	mm	mm	mm
125	25	50	200	100	12	300

Grundkrop bredde 125 mm
og længde 670 mm, 740 mm

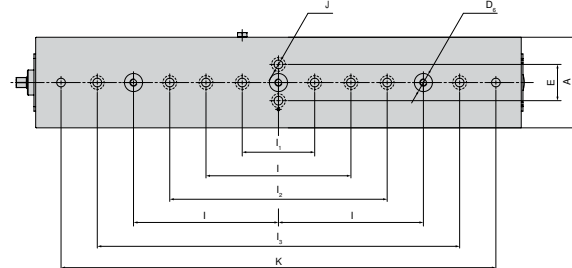

A	D ₆ H6	E ±0.015	I ±0.01	I ₁ ±0.01	I ₂ ±0.002	I ₃ ±0.025	J H7	K ±0.002
mm	mm	mm	mm	mm	mm	mm	mm	mm
125	25	50	200	100	300	500	12	600
125	25	50	200	100	300	500	12	700

DSG 4 dimensionstabel til de forskellige bakker

Med vendebakker grip og mellembakke grip

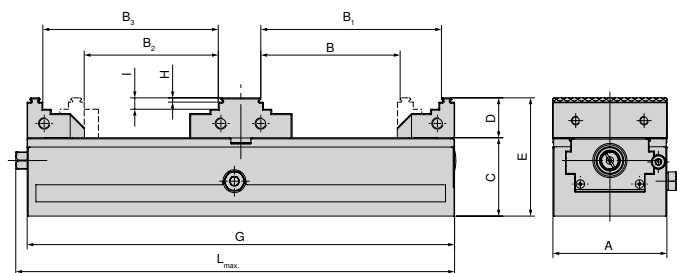

A mm	B mm	B ₁ mm	B ₂ mm	B ₃ mm	C mm	D mm	E mm	G mm	H mm	I mm	L _{max} mm	Art. nr. Systembakker
80	25 - 97	54 - 126	31 - 93	51 - 122	55	28	83	300	3	8	308	2 x 80 878 810 + 80 906 300
125	40 - 86	75 - 121	42 - 79	68 - 114	60	40	100	320	3	18	347	2 x 80 901 303 + 80 906 304
125	40 - 121	75 - 156	42 - 114	68 - 149	60	40	100	390	3	18	417	2 x 80 901 303 + 80 906 304
125	40 - 156	75 - 191	42 - 149	68 - 184	60	40	100	460	3	18	487	2 x 80 901 303 + 80 906 304
125	40 - 191	75 - 226	42 - 184	68 - 219	60	40	100	530	3	18	557	2 x 80 901 303 + 80 906 304
125	40 - 226	75 - 261	42 - 219	68 - 254	60	40	100	600	3	18	627	2 x 80 901 303 + 80 906 304
125	40 - 261	75 - 296	42 - 254	68 - 289	60	40	100	670	3	18	697	2 x 80 901 303 + 80 906 304
125	40 - 296	75 - 331	42 - 289	68 - 324	60	40	100	740	3	18	767	2 x 80 901 303 + 80 906 304

Med vendebakker grip og mellembakke grip

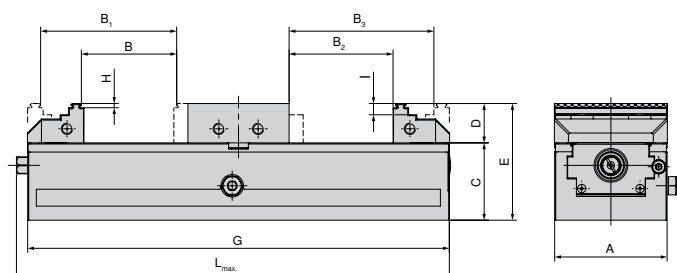

A mm	B mm	B ₁ mm	B ₂ mm	B ₃ mm	C mm	D mm	E mm	G mm	H mm	I mm	L _{max} mm	Art. nr. Systembakker
80	5 - 67	34 - 96	0 - 73	40 - 102	55	28	83	300	3	8	308	2 x 80 878 810 + 80 906 301
125	7 - 44	42 - 77	0 - 47	46 - 82	60	40	100	320	3	18	347	2 x 80 901 303 + 80 906 305
125	7 - 79	42 - 112	0 - 82	46 - 117	60	40	100	390	3	18	417	2 x 80 901 303 + 80 906 305
125	7 - 114	42 - 149	0 - 117	46 - 152	60	40	100	460	3	18	487	2 x 80 901 303 + 80 906 305
125	7 - 147	42 - 182	0 - 152	46 - 187	60	40	100	530	3	18	557	2 x 80 901 303 + 80 906 305
125	7 - 184	42 - 217	0 - 187	46 - 222	60	40	100	600	3	18	627	2 x 80 901 303 + 80 906 305
125	7 - 219	42 - 252	0 - 222	46 - 257	60	40	100	670	3	18	697	2 x 80 901 303 + 80 906 305
125	7 - 254	42 - 287	0 - 257	46 - 292	60	40	100	740	3	18	767	2 x 80 901 303 + 80 906 305

DSG 4 dimensionstabel til de forskellige bakker

Med blokbakker og mellembakke glat

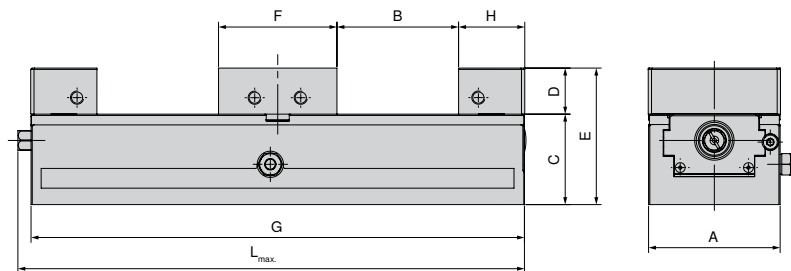

A mm	B mm	C mm	D mm	E mm	F mm	G mm	H mm	L _{max} mm	Art. nr. Systembakker
80	0 - 73	55	28	83	72	300	40	308	2 x 80 901 31300 + 80 906 301
125	0 - 46	60	40	100	98	320	66	347	2 x 80 901 31500 + 80 906 305
125	0 - 81	60	40	100	98	390	66	417	2 x 80 901 31500 + 80 906 305
125	0 - 116	60	40	100	98	460	66	487	2 x 80 901 31500 + 80 906 305
125	0 - 151	60	40	100	98	530	66	557	2 x 80 901 31500 + 80 906 305
125	0 - 186	60	40	100	98	600	66	627	2 x 80 901 31500 + 80 906 305
125	0 - 221	60	40	100	98	670	66	697	2 x 80 901 31500 + 80 906 305
125	0 - 256	60	40	100	98	740	66	767	2 x 80 901 31500 + 80 906 305

Med pendul- og adapterplade

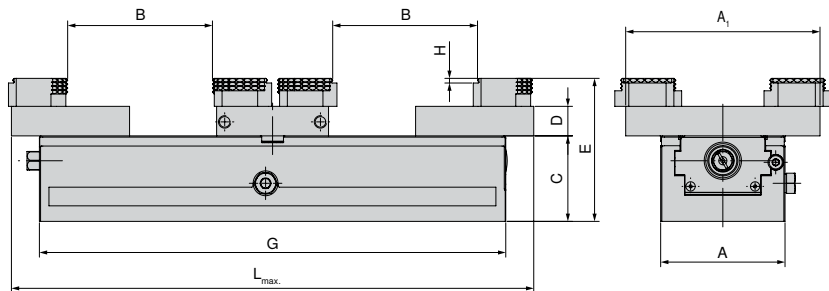

A mm	A ₁ mm	B mm	C mm	D mm	E mm	G mm	H mm	L _{max} mm	Art. nr. Systembakker
80	125	0 - 92	55	19	92	300	3	308	2 x 80 878 870 + 80 906 303
125	180	7 - 92	60	22	100	320	3	365	2 x 80 878 570 + 80 906 307
125	180	7 - 133	60	22	100	390	3	435	2 x 80 878 570 + 80 906 307
125	180	7 - 168	60	22	100	460	3	505	2 x 80 878 570 + 80 906 307
125	180	7 - 203	60	22	100	530	3	575	2 x 80 878 570 + 80 906 307
125	180	7 - 238	60	22	100	600	3	645	2 x 80 878 570 + 80 906 307
125	180	7 - 273	60	22	100	670	3	715	2 x 80 878 570 + 80 906 307
125	180	7 - 308	60	22	100	740	3	785	2 x 80 878 570 + 80 906 307

DSG 4 dimensionstabel til de forskellige bakker

Med alubakker og mellembakke alu

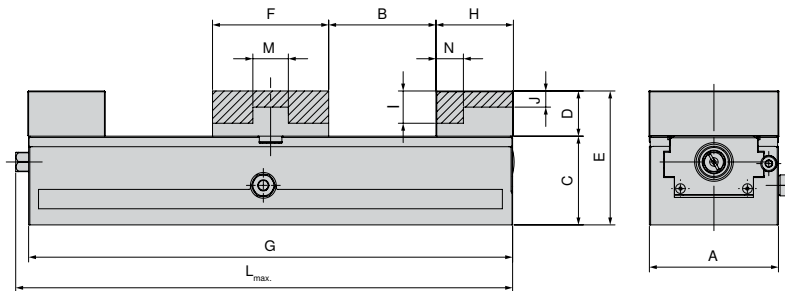

A mm	B mm	C mm	D mm	E mm	F mm	G mm	H mm	I mm	J mm	L _{max.} mm	M mm	N mm	Art. nr. Systembakker
80	0 - 66	55	28	83	72	300	40	20	10	308	22	17	2 x 80 878 850 + 80 906 302
125	0 - 42	60	40	100	98	320	68		17	347	38	28	2 x 80 878 550 + 80 906 306
125	0 - 77	60	40	100	98	390	68		17	417	38	28	2 x 80 878 550 + 80 906 306
125	0 - 112	60	40	100	98	460	68		17	487	38	28	2 x 80 878 550 + 80 906 306
125	0 - 147	60	40	100	98	530	68		17	557	38	28	2 x 80 878 550 + 80 906 306
125	0 - 182	60	40	100	98	600	68		17	627	38	28	2 x 80 878 550 + 80 906 306
125	0 - 217	60	40	100	98	670	68		17	697	38	28	2 x 80 878 550 + 80 906 306
125	0 - 252	60	40	100	98	740	68		17	767	38	28	2 x 80 878 550 + 80 906 306

Oversigt systembakker

Vendebakke, grip 3 mm, bevægelig

▲ Pris pr. stk.

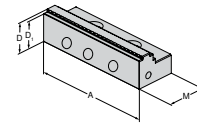

Til skruestikbredde	A	A ₁	D	D ₁	D ₂	E	M	M ₁	M ₂	DKK	Y4	NCG	H5G / -S / -Z	X5G-Z / -S	ESG 4	ESG 5	HDG 2	ZSG 4	ZSG mini	DSG 4	Verso	HSG	
125	125		40	37			66			1.676,00					●	●					●		

Vendebakke, grip 3 mm, bevægelig

▲ Pris pr. stk.

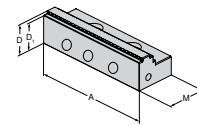

Til skruestikbredde	A	A ₁	D	D ₁	D ₂	E	M	M ₁	M ₂	DKK	Y4	NCG	H5G / -S / -Z	X5G-Z / -S	ESG 4	ESG 5	HDG 2	ZSG 4	ZSG mini	DSG 4	Verso	HSG	
80	80		28	25			40			1.010,00					●	●					●		

Mellembakke, grip

▲ Pris pr. stk.

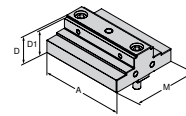

Til skruestikbredde	A	A ₁	D	D ₁	D ₂	E	M	M ₁	M ₂	DKK	Y4	NCG	H5G / -S / -Z	X5G-Z / -S	ESG 4	ESG 5	HDG 2	ZSG 4	ZSG mini	DSG 4	Verso	HSG	
80	80		28	25			72			2.079,00											●		
125	125		40	37			98			2.768,00											●		

Mellembakke, glat

▲ Pris pr. stk.

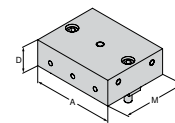

Til skruestikbredde	A	A ₁	D	D ₁	D ₂	E	M	M ₁	M ₂	DKK	Y4	NCG	H5G / -S / -Z	X5G-Z / -S	ESG 4	ESG 5	HDG 2	ZSG 4	ZSG mini	DSG 4	Verso	HSG	
80	80		28				72			1.601,00											●		
125	125		40				98			2.371,00											●		

Oversigt systembakker

Alubakke

- ▲ Til fremstilling af formbakker
- ▲ Pris pr. stk.

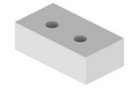
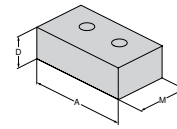

Til skruestikbredde	A	A ₁	D	D ₁	D ₂	E	M	M ₁	M ₂	DKK	Y4	NCG	H5G / -S / -Z	X5G-Z / -S	ESG 4	ESG 5	HDG 2	ZSG 4	ZSG mini	DSG 4	Verso	HSG	
80	80		28				48			646,00	80 878 850				●	●		●		●			
125	125		40				68			735,00	80 878 550				●						●		

Mellembakke alu

- ▲ Til fremstilling af formbakker
- ▲ Pris pr. stk.

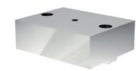
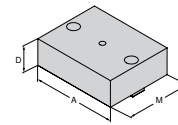

Til skruestikbredde	A	A ₁	D	D ₁	D ₂	E	M	M ₁	M ₂	DKK	Y4	NCG	H5G / -S / -Z	X5G-Z / -S	ESG 4	ESG 5	HDG 2	ZSG 4	ZSG mini	DSG 4	Verso	HSG	
80	80		28				72			582,00	80 906 302										●		
125	125		40				98			785,00	80 906 306										●		

Blokbakke, bevægelig

- ▲ Pris pr. stk.

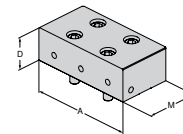

Til skruestikbredde	A	A ₁	D	D ₁	D ₂	E	M	M ₁	M ₂	DKK	Y4	NCG	H5G / -S / -Z	X5G-Z / -S	ESG 4	ESG 5	HDG 2	ZSG 4	ZSG mini	DSG 4	Verso	HSG	
80	80		28				40			1.825,00	80 901 31300				●	●		●		●			
125	125		40				66			2.558,00	80 901 31500				●						●		

Pendulbakke, bevægelig

- ▲ Rummer 6 gange vendbare bakker
- ▲ Pris pr. stk.

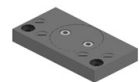
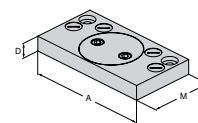

Til skruestikbredde	A	A ₁	D	D ₁	D ₂	E	M	M ₁	M ₂	DKK	Y4	NCG	H5G / -S / -Z	X5G-Z / -S	ESG 4	ESG 5	HDG 2	ZSG 4	ZSG mini	DSG 4	Verso	HSG	
80	125		19				76			3.059,00	80 878 870				●					●			
125	180		22				95			3.186,00	80 878 570				●			●		●			

Oversigt systembakker

Mellembakke adapterplade, fast

- ▲ Rummer 6 gange vendbare bakker
- ▲ Pris pr. stk.

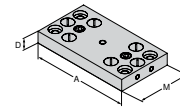

Til skruestikbredde	A	A ₁	D	D ₁	D ₂	E	M	M ₁	M ₂	DKK	Y4	NCG	H5G / -S / -Z	X5G-Z / -S	ESG 4	ESG 5	HGG 2	ZSG 4	ZSG mini	DSG 4	Verso	HSG	
80	125		19				72			2.177,00	80 906 303												
125	180		22				98			2.588,00	80 906 307												

6-fags vendebakke

- ▲ 1 = Glat, Wolfram-Carbide belagt
- ▲ 2 = Grip med trin 3 mm
- ▲ 3 = Grip med trin 8 mm
- ▲ 4 = Grip med trin 18 mm
- ▲ 5 = Grip rund med trin 8 mm
- ▲ 6 = Grip rund
- ▲ M_{max} = 60 Nm
- ▲ Inkl. fastspændingsbolte

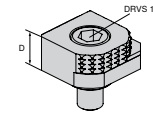

Til skruestikbredde	A	A ₁	D	D ₁	D ₂	E	M	M ₁	M ₂	DKK	Y4	NCG	H5G / -S / -Z	X5G-Z / -S	ESG 4	ESG 5	HGG 2	ZSG 4	ZSG mini	DSG 4	Verso	HSG	
			18							603,00	80 892 246	●	●	●	●	●	●	●	●	●	●	●	●

6-fags vendebakke, Carbide grip

- ▲ 1 = Glat
- ▲ 2 = Carbide grip
- ▲ 3 = Carbide grip med trin 3 mm
- ▲ 4 = Carbide grip med trin 8 mm
- ▲ 5 = Carbide grip rund med trin 8 mm
- ▲ 6 = Carbide grip rund
- ▲ Inkl. fastspændingsbolte

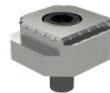
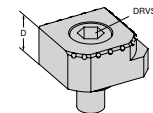

Til skruestikbredde	A	A ₁	D	D ₁	D ₂	E	M	M ₁	M ₂	DKK	Y4	NCG	H5G / -S / -Z	X5G-Z / -S	ESG 4	ESG 5	HGG 2	ZSG 4	ZSG mini	DSG 4	Verso	HSG	
			18							875,00	80 890 35300	●	●	●	●	●	●	●	●	●	●	●	●

Oversigt system-tilbehør

Blindprop kunststof

DSG
4



G	80 906 ...
M10x12	DKK Y4 9,00 500

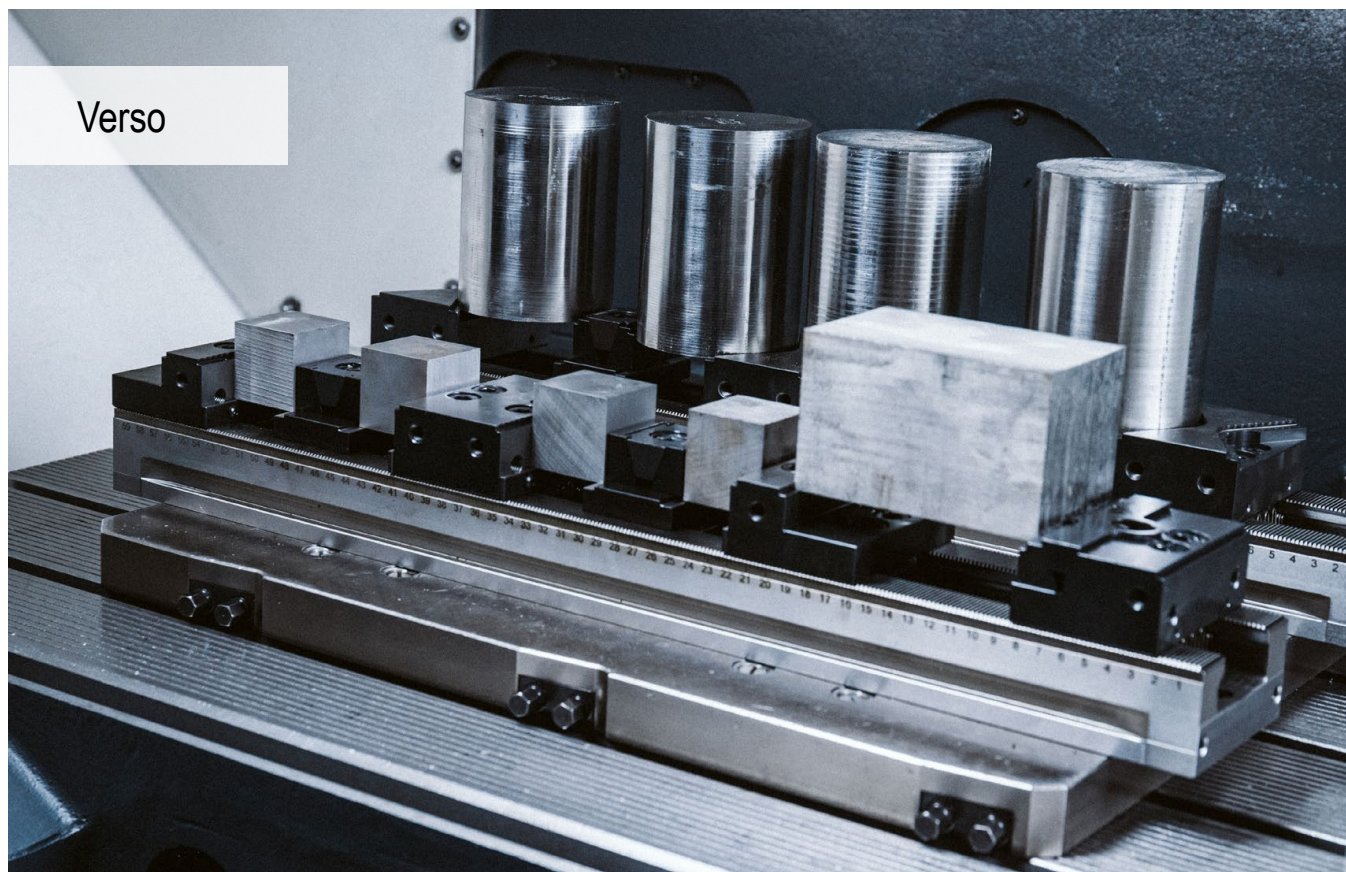

Verso

Allrounderen til emneopspænding

Den nye multiskruestik giver dig mulighed for at opspænde mange små og store emner på en 3-, 4-, eller 5-akset maskine. Endnu smallere bakker giver øget emnetykkelse. Koncentrationen af emner er nu øget yderligere takket være endnu slankere bakker.

Dine fordele:

- ▲ Hærdet og slebet fortanding sikrer den højeste præcision og formstabilitet
- ▲ Hurtigskift-bakke-system ved faste og justerbare bakker
- ▲ Komplet modulprogram til alle typer af bearbejdningscentre
- ▲ Multiopspænding med kile spændeelementer
- ▲ Omfattende bakke-modulsystem
- ▲ Enkel glideskinneforlængelse med tilslutningsstykke



Opspænding/justering:

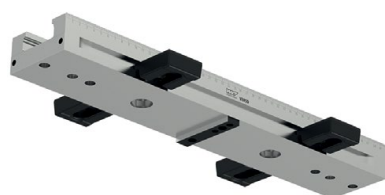

Via T-noter eller skruer
Justeret i T-not (14, 16, 18 mm)
med det dertilhørende justeringssæt
til T-noter. Til T-not 12 mm: Benyt
2 cylinderstifter Ø 12.



Med spændejern
Justeringsæt og opspænding med spændejern,
der sidder i siden.



Via rasterhuller
Placering og fastgørelse gennem to passkruer
Ø12f7 / M12, i det første og sidste hul på glideskinnen.
Yderligere forskruning med M12-cylinderskruer
gennem de øvrige huller.

Opspænding/justering:



Med nulpunktspændesystem

Glideskinnen er forsynet med MNG-interface, som gør det muligt at fastgøre MNG-spændeboltene (op til en grundkroplængde på hhv. 500 mm = 2 og fra 600 mm = 3 spændebolte).

Spændkraft:

Tilspændingsmoment / spændkraft Verso

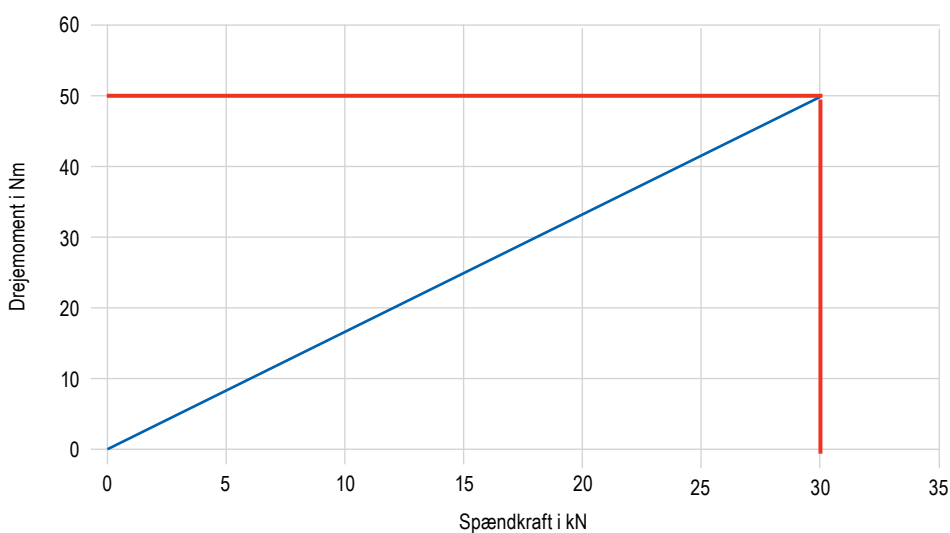

Hurtigskift-bakker til faste og justerbare bakker

Multiskruestikken Verso er som standard udstyret med et hurtigskift-bakke-system. Ved hjælp af to skruer kan de faste og justerbare bakker løsnes, tages ud eller justeres. Bakken tages ud ovenfra. Dermed kan hver bakke fjernes separat, uden at de øvrige skal afmonteres. Det reducerer opstartstiden betydeligt.



Løsn skruerne



Tag af, og sæt ind



Tilspænd skruerne

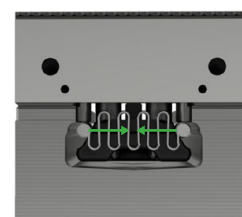

Løsne position

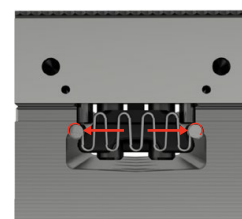

Spænde position

Hurtigskift af bakker

De faste og justerbare bakker på multiskruestiksystemet Verso er som standard udstyret med et hurtigskift-bakke-system. Ved hjælp af to skruer kan bakkerne løsnes og udskiftes. Det sikrer hurtigt bakkeskift.

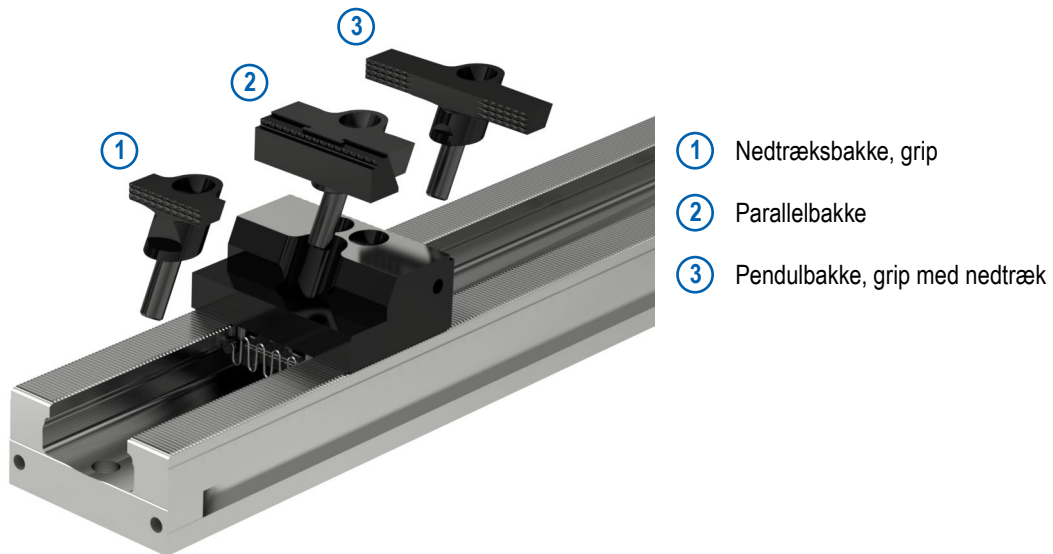

Tilslutning af glideskinnerne

To eller flere Verso-glideskinner kan forbindes med hinanden eller forlænges ved hjælp af et tilslutningsstykke.

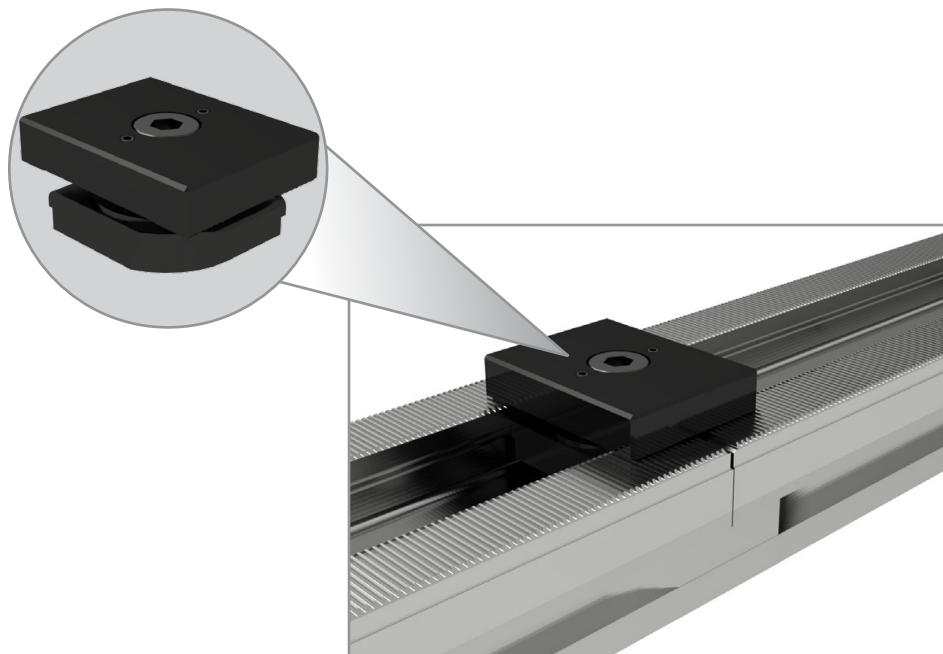

PolyClamp – Verso

- ▲ Kan anvendes til Enkel- og multiopspænding
- ▲ Multiopspænding med kile-spændeelementer
- ▲ Emner kan opspændes på 3-, 4- eller 5-aksede maskiner
- ▲ Montering på MNG med adapterplade muligt

Leveringsomfang:

Grundkrop uden bakker

Verso

MMG

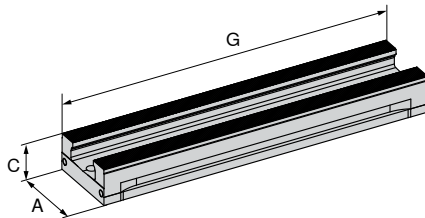

NEW

80 914 ...

DKK
Y4

A mm	C mm	G mm	MXC kN	WT kg	
90	45	260	0 - 50	5,0	6.014,00 09000
90	45	400	0 - 50	7,7	7.929,00 09100
90	45	500	0 - 50	9,6	9.574,00 09200
90	45	600	0 - 50	11,5	11.519,00 09300
90	45	650	0 - 50	12,5	12.267,00 09400

Verso – måltabel

Glideskinne

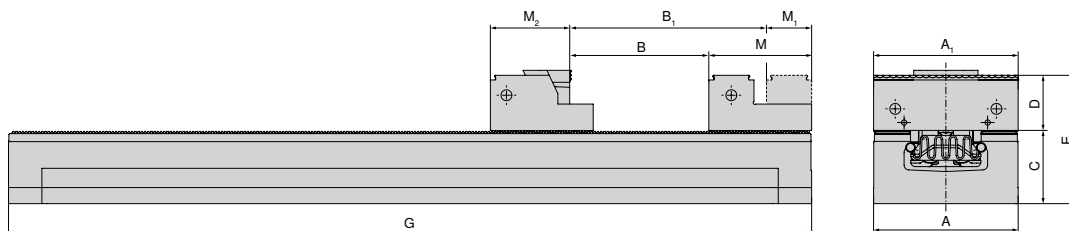

A mm	A ₁ mm	B mm	B ₁ mm	C mm	D mm	E mm	G mm	M mm	M ₁ mm	M ₂ mm
90	40 / 65 / 90	145	181	45	35	80	260	64	28	53,5
90	40 / 65 / 90	285	321	45	35	80	400	64	28	53,5
90	40 / 65 / 90	385	421	45	35	80	500	64	28	53,5
90	40 / 65 / 90	485	521	45	35	80	600	64	28	53,5
90	40 / 65 / 90	535	571	45	35	80	650	64	28	53,5



Ved brug af pendulbakke, grip 90 mm og parallelbakker afviger målene B, B₁ og M₂.

Skruestikguide

Dimensioner	115	Oversigt spændområder	116
Systemtilbehør	117-124	Alment tilbehør	164-183

Verso dimensioner

Grundkrop bredde 90 mm
og længde 260 mm

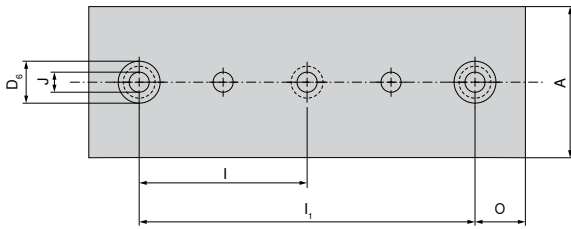

A	D ₆ H7	I ±0,015	I ₁ ±0,015	J F7	O ±0,015
mm	mm	mm	mm	mm	mm
90	25	100	200	12	30

Grundkrop bredde 90 mm
og længde 600 mm

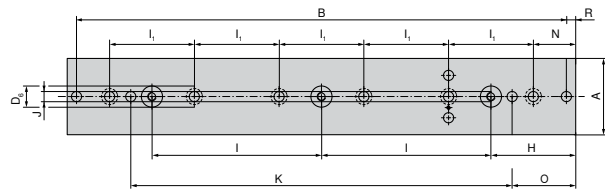

A	B	D ₆ H7	H ±0,015	I ±0,015	I ₁ ±0,015	J F7	K ±0,015	N	O ±0,015	R
mm	mm	mm	mm	mm	mm	mm	mm	mm	mm	mm
90	578	25	100	200	100	12	450	50	75	11

Grundkrop bredde 90 mm
og længde 400 mm

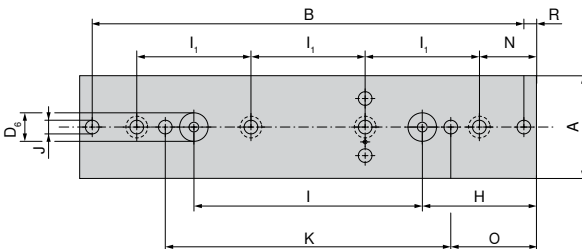

A	B	D ₆ H7	H ±0,015	I ±0,015	I ₁ ±0,015	J F7	K ±0,015	N	O ±0,015	R
mm	mm	mm	mm	mm	mm	mm	mm	mm	mm	mm
90	378	25	100	200	100	12	250	50	75	11

Grundkrop bredde 90 mm
og længde 650 mm

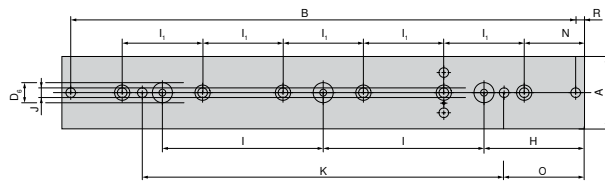

A	B	D ₆ H7	H ±0,015	I ±0,015	I ₁ ±0,015	J F7	K ±0,015	N	O ±0,015	R
mm	mm	mm	mm	mm	mm	mm	mm	mm	mm	mm
90	628	25	125	200	100	12	450	75	100	11

Grundkrop bredde 90 mm
og længde 500 mm

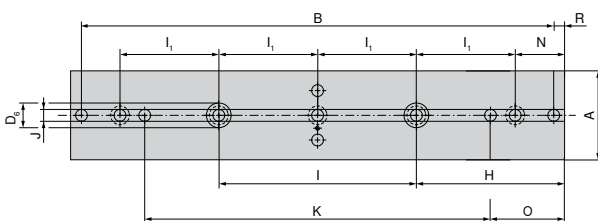

A	B	D ₆ H7	H ±0,015	I ±0,015	I ₁ ±0,015	J F7	K ±0,015	N	O ±0,015	R
mm	mm	mm	mm	mm	mm	mm	mm	mm	mm	mm
90	478	25	150	200	100	12	350	50	75	11

Oversigt Versos spændområde

Spændvidden viser den maksimale emnestørrelse afhængig af antallet af opspændingssteder for de specifikke længder på opspændingsskinne.

Justerbare bakker med nedtræksbakke, grip 40 mm

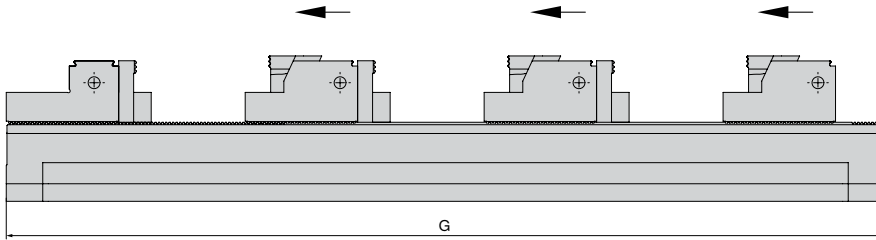

G mm	Antal emner							Art. nr. Skruestik
	1	2	3	4	5	6	7	
260	134	36	–	–	–	–	–	80 914 09000
400	274	106	50	22	–	–	–	80 914 09100
500	374	156	82	45	24	–	–	80 914 09200
600	474	206	116	72	44	26	–	80 914 09300
650	524	230	135	84	54	34	20	80 914 09400

Justerbare bakker med parallelbakker

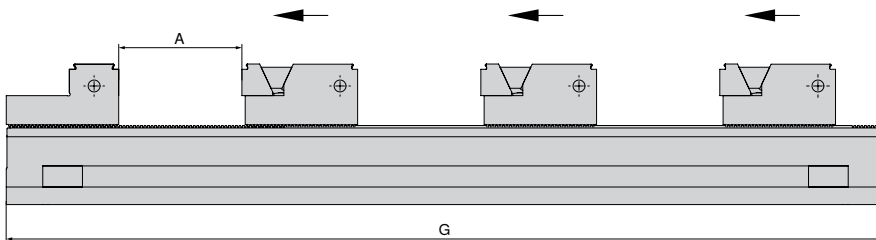

G mm	Antal emner									Art. nr. Skruestik
	1 A	2 A	3 A	4 A	5 A	6 A	7 A	8 A	9 A	
260	175	59	–	–	–	–	–	–	–	80 914 09000
400	315	129	67	27	10	–	–	–	–	80 914 09100
500	415	179	100	61	30	15	–	–	–	80 914 09200
600	515	229	133	86	57	32	19	10	–	80 914 09300
650	565	254	150	98	67	46	26	16	8	80 914 09400

Med kilespændelementer

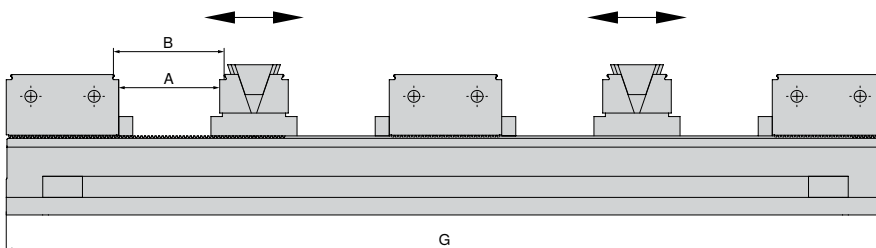

G mm	Antal emner								Art. nr. Skruestik
	2		4		6		8		
	A	B	A	B	A	B	A	B	
260	45	50	–	–	–	–	–	–	80 914 09000
400	115	120	31	36	–	–	–	–	80 914 09100
500	165	170	56	61	19	24	–	–	80 914 09200
600	215	220	81	86	36	41	14	19	80 914 09300
650	240	245	93	98	44	49	20	25	80 914 09400

Oversigt systembakker

Anslagsbakke, fast, grip 2,9 mm

▲ Pris pr. stk.

Til skruestikbredde	A	A ₁	D	D ₁	D ₂	E	M	M ₁	M ₂
90	90		32	34,9			64		

DKK
2.558,00

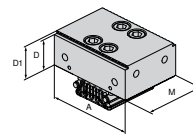

NEW

Y4

80 914 31800	NCG	H5G / -S / -Z	X5G-Z / -S	ESG 4	ESG 5	HDG 2	ZSG 4	ZSG mini	DSG 4	Versto	HSG
--------------	-----	---------------	------------	-------	-------	-------	-------	----------	-------	--------	-----

Vendebakke, fast, glat

▲ Pris pr. stk.

Til skruestikbredde	A	A ₁	D	D ₁	D ₂	E	M	M ₁	M ₂
90	90		34,9	17			64	35,9	28,1

DKK
2.723,00

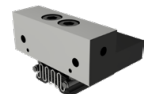
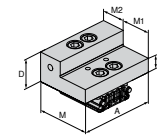

NEW

Y4

80 914 32000	NCG	H5G / -S / -Z	X5G-Z / -S	ESG 4	ESG 5	HDG 2	ZSG 4	ZSG mini	DSG 4	Versto	HSG
--------------	-----	---------------	------------	-------	-------	-------	-------	----------	-------	--------	-----

Anslagsbakke, fast, grip 2,9 mm

▲ Pris pr. stk.

Til skruestikbredde	A	A ₁	D	D ₁	D ₂	E	M	M ₁	M ₂
90	65		34,9	32	17		64	28,1	35,9
90	65	40	34,9	32	17		64	28,1	35,9
90	90		34,9	32	17		64	28,1	35,9

DKK
2.633,00
2.543,00
2.723,00

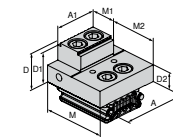

NEW

Y4

80 914 31100	NCG	H5G / -S / -Z	X5G-Z / -S	ESG 4	ESG 5	HDG 2	ZSG 4	ZSG mini	DSG 4	Versto	HSG
80 914 31000											●
80 914 31200											●

Vendbar justerbar bakke, profileret, grip 2,9 mm

▲ Pris pr. stk.

Til skruestikbredde	A	A ₁	D	D ₁	D ₂	E	M	M ₁	M ₂
90	65		34,9	32	17		64	42	22
90	65	40	34,9	32	17		64	42	22
90	90		34,9	32	17		64	42	22

DKK
2.633,00
2.543,00
2.723,00

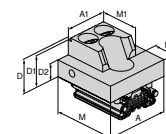

NEW

Y4

80 914 31400	NCG	H5G / -S / -Z	X5G-Z / -S	ESG 4	ESG 5	HDG 2	ZSG 4	ZSG mini	DSG 4	Versto	HSG
80 914 31300											●
80 914 31500											●

Vendbar justerbar bakke, glat

▲ Pris pr. stk.

Til skruestikbredde	A	A ₁	D	D ₁	D ₂	E	M	M ₁	M ₂
90	90		34,9	17			64	42	22

DKK
2.723,00

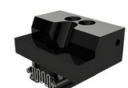
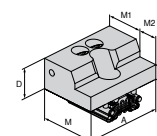

NEW

Y4

80 914 31600	NCG	H5G / -S / -Z	X5G-Z / -S	ESG 4	ESG 5	HDG 2	ZSG 4	ZSG mini	DSG 4	Versto	HSG
--------------	-----	---------------	------------	-------	-------	-------	-------	----------	-------	--------	-----

Oversigt systembakker

Vendbar justerbar bakke, høj

▲ Pris pr. stk.

Til skruestikbredde	A	A ₁	D	D ₁	D ₂	E	M	M ₁	M ₂	DKK	Y4	NEW	NCG	H5G / -S / -Z	X5G-Z / -S	ESG 4	ESG 5	HDG 2	ZSG 4	ZSG mini	DSG 4	Versto	HSG	
90	65		165				124			9.126,00	80 914 31700												●	

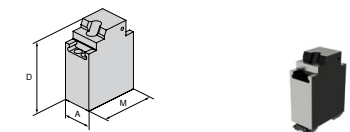

Prisemebakke, glat, grip 2,9 mm

▲ Pris pr. stk.

Til skruestikbredde	A	A ₁	D	D ₁	D ₂	E	M	M ₁	M ₂	DKK	Y4	NEW	NCG	H5G / -S / -Z	X5G-Z / -S	ESG 4	ESG 5	HDG 2	ZSG 4	ZSG mini	DSG 4	Versto	HSG	
90	90		34,9	32			64			2.723,00	80 914 31900												●	

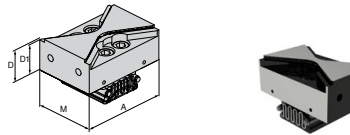

Kilebakke

▲ Pris pr. stk.

Til skruestikbredde	A	A ₁	D	D ₁	D ₂	E	M	M ₁	M ₂	DKK	Y4	NEW	NCG	H5G / -S / -Z	X5G-Z / -S	ESG 4	ESG 5	HDG 2	ZSG 4	ZSG mini	DSG 4	Versto	HSG	
90	40	65	35	11			49			2.596,00	80 914 32100												●	
90	40	65	39	11			49			1.765,00	80 914 32400												●	

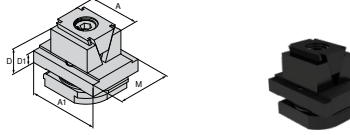

Kilebakke, grip

▲ Pris pr. stk.

Til skruestikbredde	A	A ₁	D	D ₁	D ₂	E	M	M ₁	M ₂	DKK	Y4	NEW	NCG	H5G / -S / -Z	X5G-Z / -S	ESG 4	ESG 5	HDG 2	ZSG 4	ZSG mini	DSG 4	Versto	HSG	
90	40	65	35	11			49			2.775,00	80 914 32200												●	
90	40	65	39	11			49			1.765,00	80 914 32500												●	

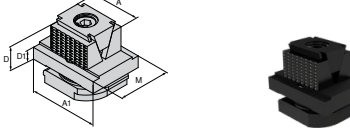

Kilebakke, grip 3 mm

▲ Pris pr. stk.

Til skruestikbredde	A	A ₁	D	D ₁	D ₂	E	M	M ₁	M ₂	DKK	Y4	NEW	NCG	H5G / -S / -Z	X5G-Z / -S	ESG 4	ESG 5	HDG 2	ZSG 4	ZSG mini	DSG 4	Versto	HSG	
90	40	65	35	32			49			2.775,00	80 914 32300												●	

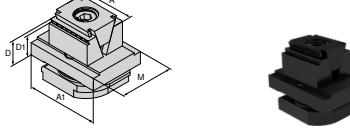

Oversigt systembakker

Bakke, grip

▲ Pris pr. stk.

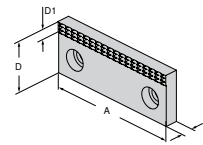

Til skruestikbredde	A	A ₁	D	D ₁	D ₂	E	M	M ₁	M ₂	DKK	NEW	Y4	NCG	H5G / -S / -Z	X5G-Z / -S	ESG 4	ESG 5	HDG 2	ZSG 4	ZSG mini	DSG 4	Verso	HSG	
65	65		35	7			10			307,00		80 889 656												
65	40		35	7			10			275,00		80 889 406												●
90	90		35	7			10			348,00		80 889 906												●

Blød bakke

▲ Materiale: 16MnCr5

▲ Pris pr. stk.

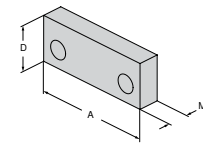

Til skruestikbredde	A	A ₁	D	D ₁	D ₂	E	M	M ₁	M ₂	DKK	NEW	Y4	NCG	H5G / -S / -Z	X5G-Z / -S	ESG 4	ESG 5	HDG 2	ZSG 4	ZSG mini	DSG 4	Verso	HSG	
65	65		35				16			307,00		80 889 657												●
65	40		35				16			283,00		80 889 407												●
90	90		35				16			372,00		80 889 907												●

Basisbakke

▲ Pris pr. stk.

▲ For alu-bakker, artikel nr. 80 914 34200

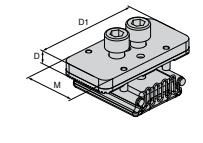

Til skruestikbredde	A	A ₁	D	D ₁	D ₂	E	M	M ₁	M ₂	DKK	NEW	Y4	NCG	H5G / -S / -Z	X5G-Z / -S	ESG 4	ESG 5	HDG 2	ZSG 4	ZSG mini	DSG 4	Verso	HSG	
90			9,1	80			40			1.586,00		80 914 34100											●	

Blød alu-bakke

▲ Pris pr. stk.

▲ Kan kun bruges med basisbakke, artikel nr. 80 914 34100

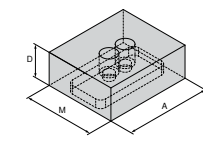

Til skruestikbredde	A	A ₁	D	D ₁	D ₂	E	M	M ₁	M ₂	DKK	NEW	Y4	NCG	H5G / -S / -Z	X5G-Z / -S	ESG 4	ESG 5	HDG 2	ZSG 4	ZSG mini	DSG 4	Verso	HSG	
90	90		34,9				75			606,00		80 914 34200											●	

Nedtræksbakke, grip

▲ Pris pr. stk.

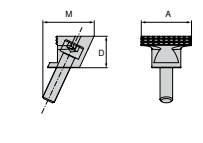

Til skruestikbredde	A	A ₁	D	D ₁	D ₂	E	M	M ₁	M ₂	DKK	NEW	Y4	NCG	H5G / -S / -Z	X5G-Z / -S	ESG 4	ESG 5	HDG 2	ZSG 4	ZSG mini	DSG 4	Verso	HSG	
90	40		25				41			785,00		80 914 32600											●	

Oversigt systembakker

Nedtræksbakke, grip – rund

▲ Pris pr. stk.

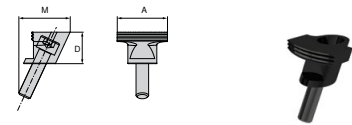

Til skruestikbredde	A	A ₁	D	D ₁	D ₂	E	M	M ₁	M ₂
90	40		25				41		

DKK

NEW

Y4

883,00

80 914 32700

NCG	H5G / -S / -Z	X5G-Z / -S	ESG 4	ESG 5	HDG 2	ZSG 4	ZSG mini	DSG 4	Versto	HSG
									●	

Parallelbakke, grip – rund

▲ Pris pr. stk.

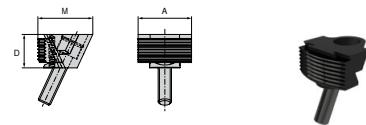

Til skruestikbredde	A	A ₁	D	D ₁	D ₂	E	M	M ₁	M ₂
90	40		25				41		

DKK

NEW

Y4

1.638,00

80 914 32800

NCG	H5G / -S / -Z	X5G-Z / -S	ESG 4	ESG 5	HDG 2	ZSG 4	ZSG mini	DSG 4	Versto	HSG
									●	

Parallelbakke

▲ Pris pr. stk.

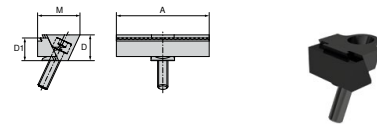

Til skruestikbredde	A	A ₁	D	D ₁	D ₂	E	M	M ₁	M ₂
90	40		25	22			41		
90	65		25	22			41		
90	90		25	22			41		

DKK

NEW

Y4

1.309,00

80 914 32900

1.616,00

80 914 33000

1.937,00

80 914 33100

NCG	H5G / -S / -Z	X5G-Z / -S	ESG 4	ESG 5	HDG 2	ZSG 4	ZSG mini	DSG 4	Versto	HSG
									●	
									●	
									●	

Pendulbakke, grip

▲ Pris pr. stk.

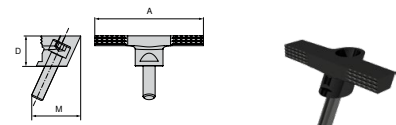

Til skruestikbredde	A	A ₁	D	D ₁	D ₂	E	M	M ₁	M ₂
90	90		25				41		

DKK

NEW

Y4

1.361,00

80 914 33200

NCG	H5G / -S / -Z	X5G-Z / -S	ESG 4	ESG 5	HDG 2	ZSG 4	ZSG mini	DSG 4	Versto	HSG
									●	

Spændkile

▲ Pris pr. stk.

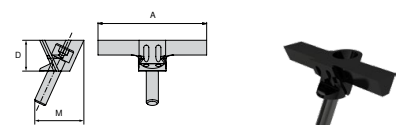

Til skruestikbredde	A	A ₁	D	D ₁	D ₂	E	M	M ₁	M ₂
90	90		25				41		

DKK

NEW

Y4

1.496,00

80 914 33300

NCG	H5G / -S / -Z	X5G-Z / -S	ESG 4	ESG 5	HDG 2	ZSG 4	ZSG mini	DSG 4	Versto	HSG
									●	

Oversigt systembakker

Parallelbakke, glat

▲ Pris pr. stk.

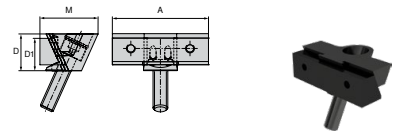

Til skruestikbredde	A	A ₁	D	D ₁	D ₂	E	M	M ₁	M ₂	DKK	NEW	Y4	NCG	H5G / -S / -Z	X5G-Z / -S	ESG 4	ESG 5	HDG 2	ZSG 4	ZSG mini	DSG 4	Veriso	HSG	
90	40		25	22			41			1.249,00		80 914 33400												
90	65		25	22			41			2.027,00		80 914 33500												
90	90		25	22			41			2.139,00		80 914 33600												

Parallelbakke, grip

▲ Pris pr. stk.

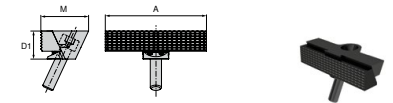

Til skruestikbredde	A	A ₁	D	D ₁	D ₂	E	M	M ₁	M ₂	DKK	NEW	Y4	NCG	H5G / -S / -Z	X5G-Z / -S	ESG 4	ESG 5	HDG 2	ZSG 4	ZSG mini	DSG 4	Veriso	HSG	
90	90			25			42,5			1.937,00		80 914 33700												

Bakke, stål

▲ Materiale: 16MnCr5

▲ Pris pr. stk.

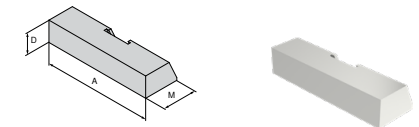

Til skruestikbredde	A	A ₁	D	D ₁	D ₂	E	M	M ₁	M ₂	DKK	NEW	Y4	NCG	H5G / -S / -Z	X5G-Z / -S	ESG 4	ESG 5	HDG 2	ZSG 4	ZSG mini	DSG 4	Veriso	HSG	
90	90		18				30			622,00		80 914 33800												

Bakke, alu

▲ Pris pr. stk.

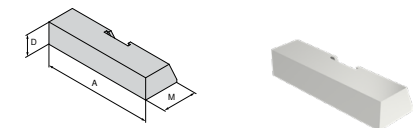

Til skruestikbredde	A	A ₁	D	D ₁	D ₂	E	M	M ₁	M ₂	DKK	NEW	Y4	NCG	H5G / -S / -Z	X5G-Z / -S	ESG 4	ESG 5	HDG 2	ZSG 4	ZSG mini	DSG 4	Veriso	HSG	
90	90		18				30			622,00		80 914 33900												

Adapterbakke, fast

▲ Rummer 6 gange vendbare bakker

▲ Pris pr. stk.

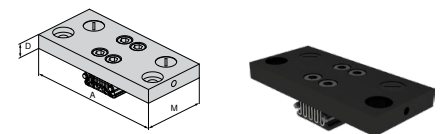

Til skruestikbredde	A	A ₁	D	D ₁	D ₂	E	M	M ₁	M ₂	DKK	NEW	Y4	NCG	H5G / -S / -Z	X5G-Z / -S	ESG 4	ESG 5	HDG 2	ZSG 4	ZSG mini	DSG 4	Veriso	HSG	
90	160		17				74			3.388,00		80 914 34000												

Oversigt systembakker

6-fags vendebakke

- ▲ 1 = Glat, Wolfram-Carbide belagt
- ▲ 2 = Grip med trin 3 mm
- ▲ 3 = Grip med trin 8 mm
- ▲ 4 = Grip med trin 18 mm
- ▲ 5 = Grip rund med trin 8 mm
- ▲ 6 = Grip rund
- ▲ $M_{max} = 60 \text{ Nm}$
- ▲ Inkl. fastspændingsbolte

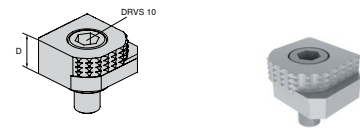

Til skruestikbredde	A	A ₁	D	D ₁	D ₂	E	M	M ₁	M ₂	DKK	Y4	NCG	H5G / -S / -Z	X5G-Z / -S	ESG 4	ESG 5	HDG 2	ZSG 4	ZSG mini	DSG 4	Verso	HSG
			18							603,00	80 892 246	●	●	●	●			●		●	●	

6-fags vendebakke, Carbide grip

- ▲ 1 = Glat
- ▲ 2 = Carbide grip
- ▲ 3 = Carbide grip med trin 3 mm
- ▲ 4 = Carbide grip med trin 8 mm
- ▲ 5 = Carbide grip rund med trin 8 mm
- ▲ 6 = Carbide grip rund
- ▲ Inkl. fastspændingsbolte

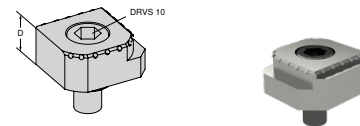

Til skruestikbredde	A	A ₁	D	D ₁	D ₂	E	M	M ₁	M ₂	DKK	Y4	NCG	H5G / -S / -Z	X5G-Z / -S	ESG 4	ESG 5	HDG 2	ZSG 4	ZSG mini	DSG 4	Verso	HSG
			18							875,00	80 890 35300	●	●	●	●			●		●	●	

Oversigt emnestøtter

Emneunderstøtning

▲ Pris pr. 2 stk.

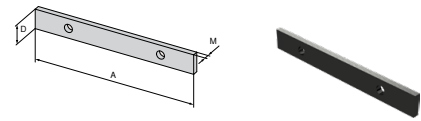

Til skruestikbredde	A	A ₁	D	D ₁	D ₂	E	M	M ₁	M ₂	DKK	NEW	Y4	NCG	H5G / -S / -Z	X5G-Z / -S	ESG 4	ESG 5	HDG 2	ZSG 4	ZSG mini	DSG 4	Verso	HSG	
90	90		11						3	396,00		80 914 73100											•	

Emneunderstøtning, forskudt

▲ Pris pr. 2 stk.

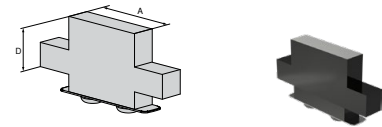

Til skruestikbredde	A	A ₁	D	D ₁	D ₂	E	M	M ₁	M ₂	DKK	NEW	Y4	NCG	H5G / -S / -Z	X5G-Z / -S	ESG 4	ESG 5	HDG 2	ZSG 4	ZSG mini	DSG 4	Verso	HSG	
90	40		30							654,00		80 914 70200											•	
90	40		25							654,00		80 914 70100											•	

Emneunderstøtning, forskudt

▲ Pris pr. 2 stk.

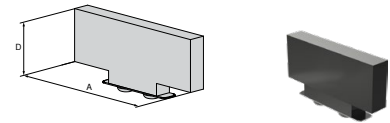

Til skruestikbredde	A	A ₁	D	D ₁	D ₂	E	M	M ₁	M ₂	DKK	NEW	Y4	NCG	H5G / -S / -Z	X5G-Z / -S	ESG 4	ESG 5	HDG 2	ZSG 4	ZSG mini	DSG 4	Verso	HSG	
90	65		11							654,00		80 914 71100											•	
90	65		17							654,00		80 914 71200											•	
90	65		25							654,00		80 914 71300											•	
90	65		30							654,00		80 914 71400											•	

Emneunderstøtning, forskudt

▲ Pris pr. 2 stk.

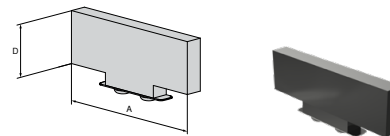

Til skruestikbredde	A	A ₁	D	D ₁	D ₂	E	M	M ₁	M ₂	DKK	NEW	Y4	NCG	H5G / -S / -Z	X5G-Z / -S	ESG 4	ESG 5	HDG 2	ZSG 4	ZSG mini	DSG 4	Verso	HSG	
90	90		11							654,00		80 914 72100											•	
90	90		17							654,00		80 914 72200											•	
90	90		25							654,00		80 914 72300											•	
90	90		30							654,00		80 914 72400											•	

Oversigt system-tilbehør

Justerbar understøtning med grundholder

- ▲ Til vibrationsdæmpning
- ▲ højdejusterbar 16 – 17 mm

Verso

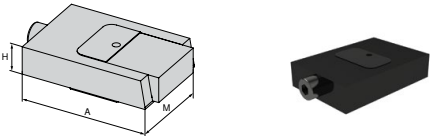

NEW

H mm	A mm	M mm	80 914 ...
16	72	50	DKK Y4 1.818,00 50100

Opspændingsboltsæt til T-not til MNG

- Leveringsomfang:
Opspændingsbolt med T-not

Verso



NEW

Til notbredde mm	G	80 914 ...
20	M12	DKK Y4 316,00 50500
22	M12	DKK Y4 372,00 50600
24	M12	DKK Y4 453,00 50700

Støtte

- ▲ Til vibrationsdæmpning: Artikel-nr. 80 914 50100

Verso

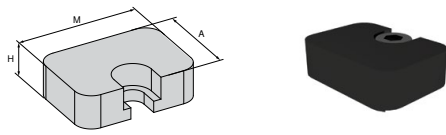

NEW

H mm	A mm	M mm	80 914 ...
8	20	28	DKK Y4 469,00 50200
13	20	28	DKK Y4 469,00 50300

Justeringstap

Verso



NEW

D ₁ mm	D ₂ mm	80 914 ...
12	14	DKK Y4 800,00 81400
12	16	DKK Y4 800,00 81600
12	18	DKK Y4 800,00 81800

Tilslutningsstykke

- ▲ Til tilslutning af 2 grundkroppe

Verso

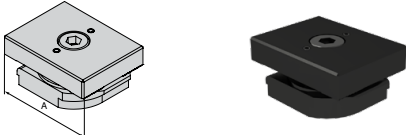

NEW

A mm	80 914 ...
90	DKK Y4 1.369,00 50400

Afskærmning

Verso

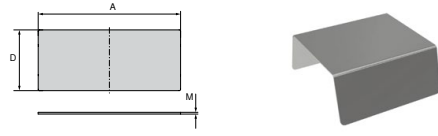

NEW

A mm	D mm	M mm	80 914 ...
50	84	0,5	DKK Y4 118,00 51000
50	86	0,5	DKK Y4 51,00 50800
200	86	0,5	DKK Y4 76,00 50900

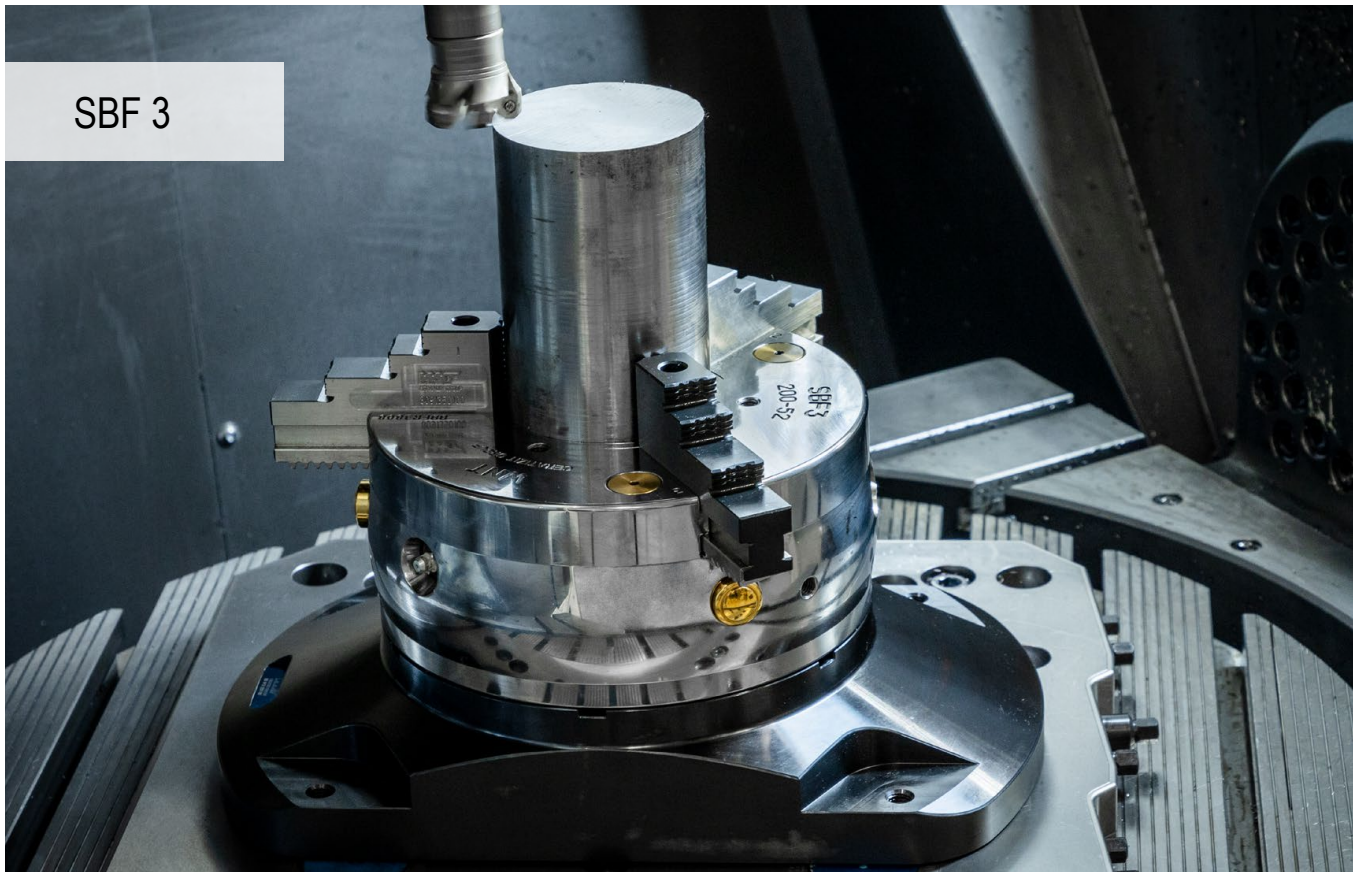

Ventet med spænding – nu også til runde komponenter

Bearbejdningen af runde komponenter er blevet daglig rutine for mange virksomheder. Med den stationære trebakkepatron SBF 3 har vi nu en løsning i sortimentet – fuldt kompatibel med vores egne nulpunktspændesystemer MNG og PNG for hurtig, ukompliceret håndtering.

Dine fordele:

- ▲ Egnet til 3/5-akset bearbejdning af runde komponenter
- ▲ Kompatibel med PNG- og MNG-nulpunkt-spændesystemer
- ▲ Hurtigskift-bakke-system med enkelt oplåsning af bakkerne
- ▲ Spindel med sekskanttilslutning



SBF 3 Ø 200 mm



SBF 3 Ø 315 mm

Teknisk information – tværsnit

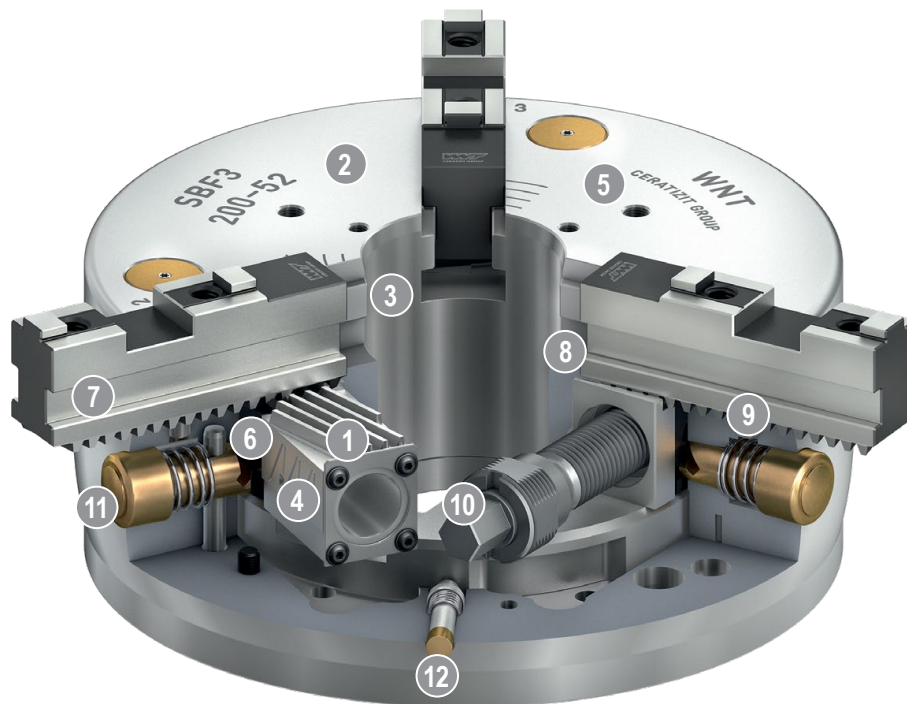

- | | |
|--|--|
| <p>1 Kilestangsdrev
muliggør fremragende bearbejdningsresultater</p> | <p>7 Grundbakker med skrå fortanding (SFG)</p> |
| <p>2 Hærdet og ekstrem solid grundkrop
dermed længere levetid og højeste præcision – selv ved højeste spændkraft</p> | <p>8 Låsemekanisme
garanterer et sikkert indgreb af grundbakkens fortandning med kilestangens fortandning</p> |
| <p>3 Stort gennemgående hul
til bearbejdning af alle gængse stangmateriale diametre (som tilvalg: udvidelse af gennemgangshullet)</p> | <p>9 Låsestift
til forpositionering af grundbakken</p> |
| <p>4 Optimeret smøresystem
for høj effekt</p> | <p>10 Betjening via sekskanttilslutning
dermed lettere betjening</p> |
| <p>5 Fastgørelsesgevind
til emnestop eller dækplade</p> | <p>11 Trykknop til bakkeskift
til korteste opstillingstider</p> |
| <p>6 Hurtigskift-bakke-system
med enkelt oplåsning af bakkerne, hvilket sikrer den korteste omstillingstid</p> | <p>12 Indikatorstift
til slagovervågning af den manuelle borepatron</p> |

Trebakkepatron SBF 3 (Ø 200 mm) med konsol

- ▲ Velegnet til 3/5-akset bearbejdning af runde komponenter
- ▲ Kompatibel med PNG- og MNG-nulpunktspændesystemer (nulpunktspændebolte skal bestilles separat)
- ▲ Hurtigskift-bakke-system med enkel bakke aktivering
- ▲ Spindel med sekskant tilslutning

Leveringsomfang:

Trebakkepatron SBF 3 (Ø 200 mm) inkl. konsol (PNG- og MNG-kompatibel)

1 sæt grundbakker GBA

1 sæt trinbakker SB-H

6 fastspændingsbolte og spændenøgle

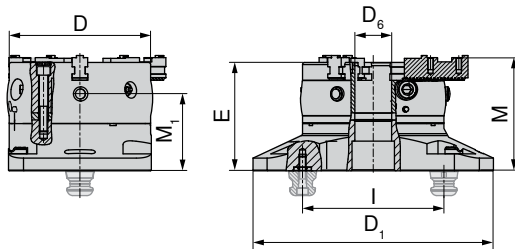

D	D ₁	D ₆	E	I	M	M ₁	MXC	TQX	DRVS	Slag / bakke	Tanddeling	WT
mm	mm	mm	mm	mm	mm	mm	kN	Nm	mm	mm	mm	kg
200	340	52	153,3	200	160,1	108,8	100	120	12	7	4,8	49,5

80 913 ...

DKK
Y4

29.651,00 20000

Trebakkepatron SBF 3 (Ø 315 mm) med konsol

- ▲ Velegnet til 3/5-akset bearbejdning af runde komponenter
- ▲ Kompatibel med PNG- og MNG-nulpunktspændesystemer (nulpunktspændebolte skal bestilles separat)
- ▲ Hurtigskift-bakke-system med enkel bakke aktivering
- ▲ Spindel med sekskant tilslutning

Leveringsomfang:

Trebakkepatron SBF 3 (Ø 315 mm) inkl. konsol (PNG- og MNG-kompatibel)

1 sæt grundbakker GBA

1 sæt trinbakker SB-H

6 fastspændingsbolte og spændenøgle

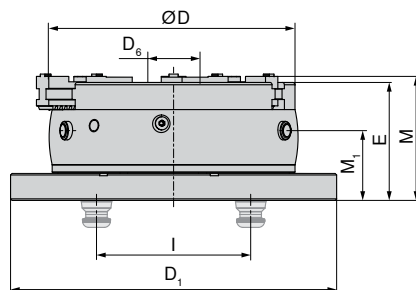

D	D ₁	D ₆	E	I	M	M ₁	MXC	TQX	DRVS	Slag / bakke	Tanddeling	WT
mm	mm	mm	mm	mm	mm	mm	kN	Nm	mm	mm	mm	kg
315	423	92	153	200	160,86	90,5	180	220	16	9,9	7	95

80 913 ...

DKK
Y4

48.897,00 31500



Patronen er udelukkende til stationært brug – må ikke anvendes under omdrejninger!

Oversigt systembakker

Grundbakker (GBA) – sæt

▲ Grundbakke med skrå fortanding

▲ Pris pr. sæt á 3 stk.

Leveringsomfang:

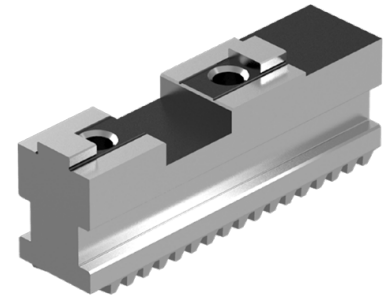
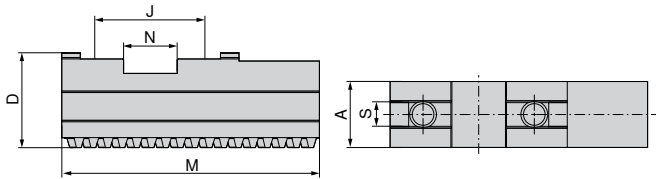
3 grundbakker med skrå fortanding
inkl. cylinderskruerSBF
3

til	A	D	J	M	N	S	G	WT
	mm	mm	mm	mm	mm	mm		kg
SBF-3.200	22	32	40	90	20	10	M8x1	1,2
SBF-3.315	32	43	54	125	26	12	M12x1,5	3,1

80 913 ...

DKK
Y4

1.810,00 50300

2.992,00 60300

Bløde bakker (AB-W) – sæt

▲ Pris pr. sæt á 3 stk.

▲ Materiale: 16MnCr5

Leveringsomfang:

3 bløde bakker

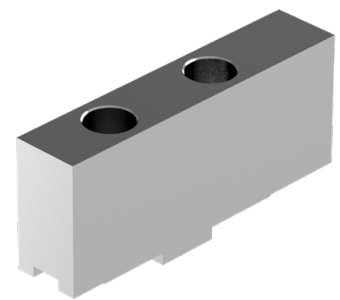
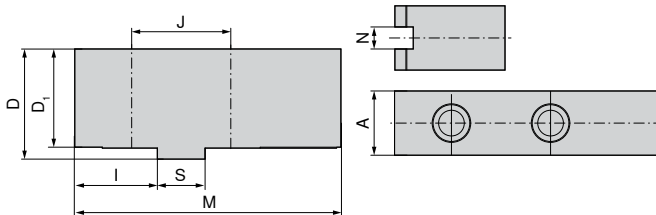
SBF
3

til	A	D	D ₁	I	J	M	N	S	Hul til	WT
	mm	mm	mm	mm	mm	mm	mm	mm		kg
SBF-3.200	22	47	43	35	40	105	10	20	M8	2,0
SBF-3.315	35	60	54	45	54	145	12	26	M12	5,6

80 913 ...

DKK
Y4

354,00 50400

735,00 60400

Oversigt systembakker

Hårde trinbakker (AB-H) – sæt

▲ Pris pr. sæt á 3 stk.

Leveringsomfang:

3 hårde trinbakker

**SBF
3**

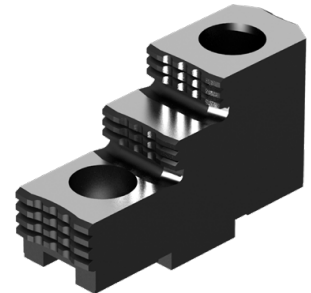
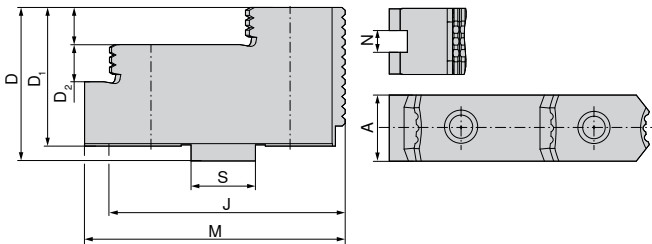

til	A mm	D mm	D ₁ mm	D ₂ mm	J mm	M mm	N mm	S mm	Hul til	WT kg	80 913 ...
SBF-3.200	22	42	38	10	40	71,7	10	20	M8	2,4	DKK Y4 1.548,00 50200
SBF-3.315	36	62	56	15	54	105	12	26	M12	3,3	2.266,00 60200

Måltabel – hårde trinbakker (AB-H)

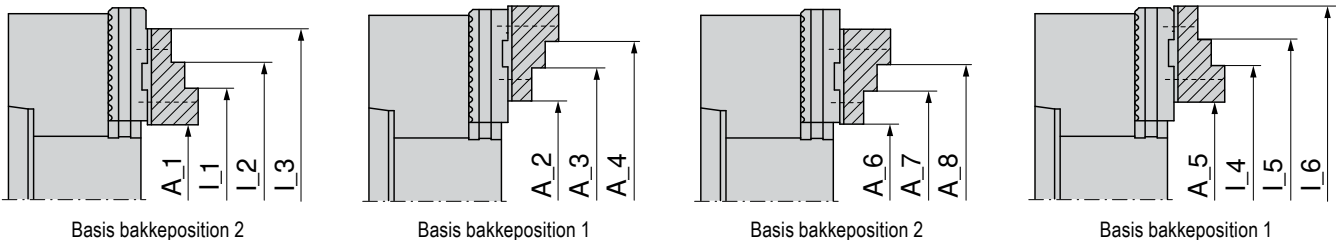

Trebakkepatron	Systembakke	Udvendig opspænding								
		A_1	A_2	A_3	A_4	A_5	A_6	A_7	A_8	
SBF-3.200	80 913 50200	SBF-3.AB-H.200.71.7.22.10	7-76	57-125	108-177	135-204	55-125	14-77	66-129	93-156
SBF-3.315	80 913 60200	SBF-3.AB-H.315.105.36.15	14-125	93-224	202-333	-	87-219	44-130	153-239	-

Trebakkepatron	Systembakke	Indvendig opspænding						
		L_1	L_2	L_3	L_4	L_5	L_6	
SBF-3.200	80 913 50200	SBF-3.AB-H.200.71.7.22.10	72-141	99-168	151-220	120-189	147-216	199-268
SBF-3.315	80 913 60200	SBF-3.AB-H.315.105.36.15	93-204	202-313	-	167-298	276-407	-

Oversigt systembakker

Hårde trinblokbakker (SB-H) – sæt

▲ Trinblokbakker med skrå fortanding

▲ Pris pr. sæt á 3 stk.

Leveringsomfang:

3 hårde trinblokbakker

**SBF
3**

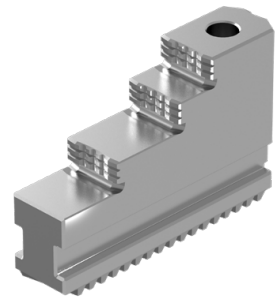
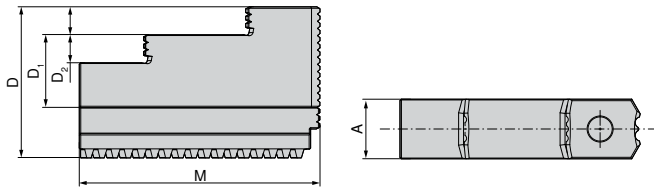

til	A	D	D ₁	D ₂	M	WT
	mm	mm	mm	mm	mm	kg
SBF-3.200	22	60	35	10	94	1,9
SBF-3.315	32	81	46	15	129	5,5

80 913 ...

DKK
Y4

3.142,00 **50100**

4.944,00 **60100**

Måltabel – hårde trinblokbakker (SB-H)

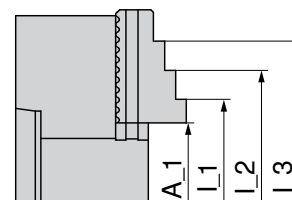

Hårde trinblokbakker
Stål 16MnCr5, indsatshærdede

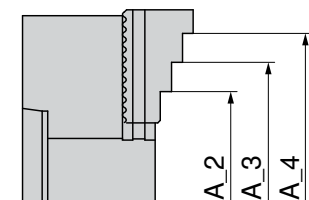

Hårde trinblokbakker
Stål 16MnCr5, indsatshærdede

Trebakkepatron	Systembakke	Udvendig opspænding				Indvendig opspænding			
		A_1	A_2	A_3	A_4	L_1	L_2	L_3	
SBF-3.200	80 913 50100	SBF-3.SB-H.200.94.22.10	6–74	59–128	111–180	138–207	70–138	97–165	149–217
SBF-3.315	80 913 60100	SBF-3.SB-H.315.129.32.15	12–124	89–210	189–420	–	91–203	199–311	–

Maskin-håndskruestik

- ▲ Handy, universal skruestik med stort spændeområde
- ▲ Bakker med trin samt horisontal og vertikal prisme 120°
- ▲ Valgfrit emnestop kan anvendes i begge sider

HSG

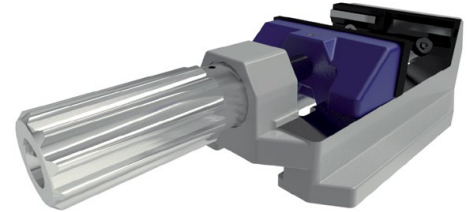
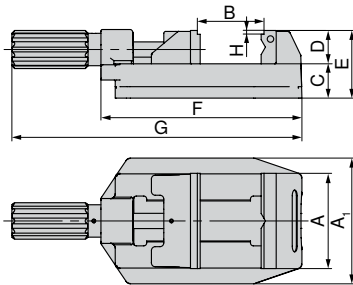

A	A ₁	B	C	D	E	F	G	H	WT
mm	mm	mm	mm	mm	mm	mm	mm	mm	kg
80	112	0 - 81	36	35	71	194	286,5	4	4,5
100	132	0 - 100	36	35	71	211	304,5	4	5,6
125	156	0 - 131	40	40	84	274	386	4	11,2

80 893 ...

DKK
Y4

2.139,00 080

2.266,00 100

3.785,00 125

Maskin-håndskruestik med spændehjælp

- ▲ Sikker og hurtig emneopspænding ved hjælp af spændearm
- ▲ Handy, universal skruestik med stort spændeområde
- ▲ Bakker med trin samt horisontal og vertikal prisme 120°
- ▲ Valgfrit materialestop kan bruges på begge sider
- ▲ N = indstillingsområde med spændearm

HSG

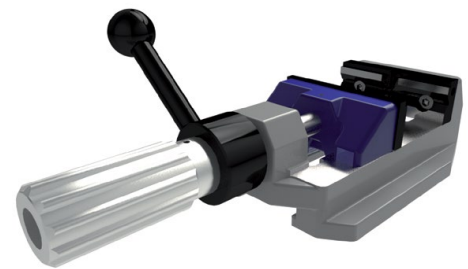
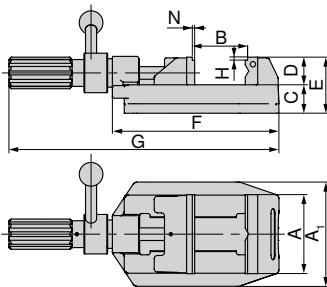

A	A ₁	B	C	D	E	F	G	H	N	WT
mm	mm	mm	mm	mm	mm	mm	mm	mm	mm	kg
100	132	0 - 100	36	35	71	211	342	4	1,5	6,1
125	156	0 - 133	44	40	84	274	405	4	1,5	11,7

80 893 ...

DKK
Y4

3.673,00 101

5.251,00 126

Skruestikguide

Systemtilbehør

132+133 Alment tilbehør

164-183

Oversigt topbakker

Trinbakke, glat

▲ Pris pr. stk.

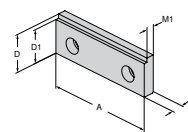

Til skruestikbredde	A	A ₁	D	D ₁	D ₂	E	M	M ₁	M ₂	DKK	Y4	NCG	H5G / -S / -Z	X5G-Z / -S	ESG 4	ESG 5	HDG 2	ZSG 4	ZSG mini	DSG 4	Verso	HSG		
80			35	31			10,2	7,2		367,00	80 893 082												●	
100			35	31			10,2	7,2		337,00	80 893 102													●
125			40	36			11,8	8,8		434,00	80 893 127													●

Trinbakke, 17 mm

▲ Pris pr. stk.

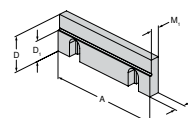

Til skruestikbredde	A	A ₁	D	D ₁	D ₂	E	M	M ₁	M ₂	DKK	Y4	NCG	H5G / -S / -Z	X5G-Z / -S	ESG 4	ESG 5	HDG 2	ZSG 4	ZSG mini	DSG 4	Verso	HSG		
125			40	23			11,5	9,5		920,00	80 892 244													●

Topbakke

▲ Prismebakke med vandret- og lodret prisme

▲ Pris pr. stk.

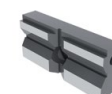
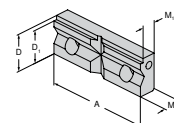

til spænddiameter	A	A ₁	D	D ₁	D ₂	E	M	M ₁	M ₂	DKK	Y4	NCG	H5G / -S / -Z	X5G-Z / -S	ESG 4	ESG 5	HDG 2	ZSG 4	ZSG mini	DSG 4	Verso	HSG			
9 - 31	80		35	31			15,8	12,8		434,00	80 893 083													●	
9 - 31	100		35	31			15,8	12,8		554,00	80 893 103														●
11 - 41	125		40	36			17,8	14,8		965,00	80 893 128														●



→ Side 164–173

Her finder du andre matchende topbakker.

Oversigt system-tilbehør

Emnestop

- ▲ Fastgøres på hoveddelen, evt. venstre, højre eller i begge sider.
Længdejusteringen udføres hurtigt og sikkert via en spændeskru.

HSG



Til bredde mm
80/100/125

80 893 ...

DKK
Y4
344,00 265

Ledeskinne

- ▲ Forhindrer rundtrækning og op hævnning

HSG

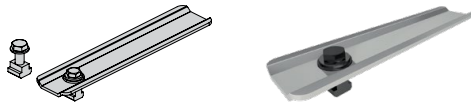

Til bredde mm
80/100/125

80 893 ...

DKK
Y4
374,00 260

Opspændingssæt

- ▲ Via en forskydelig understøtning med excentrisk drejeplade kan der oprettes vilkårlige opspændingspositioner på maskinbordet med forskellige T-not-anordninger. Skruestikgrundkroppens indvendige not giver en ekstra fastgørelsesmulighed, ligesom 80 893 260 ledeskinne.
- ▲ Pris pr. sæt

Leveringsomfang:

2 positionerings-klamper inkl. opspændingstilbehør.

HSG



Til bredde mm
80/100/125

Til notbredde mm
12/14

80 893 ...

DKK
Y4
987,00 250

Oversigt MNG- og PNG-nulpunkt-spændesystem

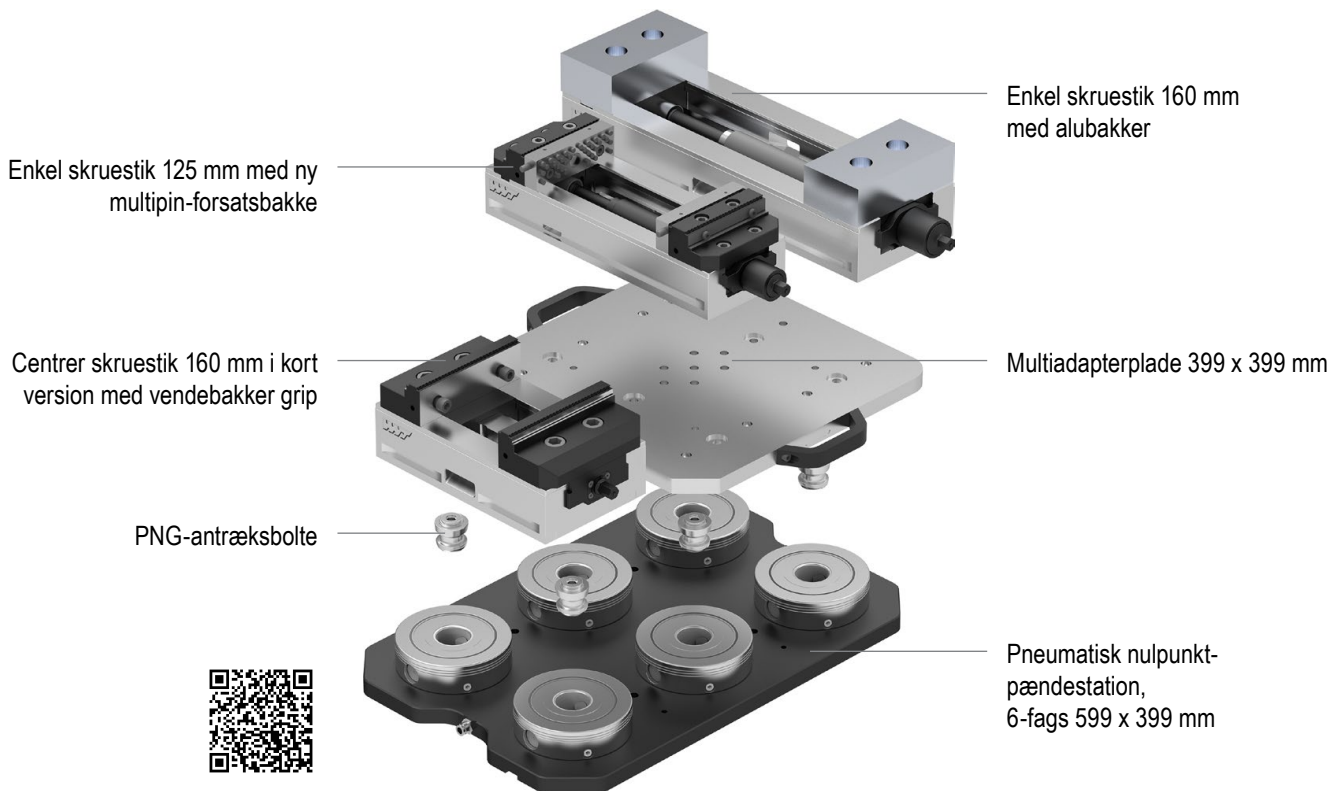

MNG – Grundplade rund

- ▲ MNG – Mekanisk Nulpunktsspændesystem
- ▲ Hærdet og slebet
- ▲ Gentagelsesnøjagtighed $\leq 0,01\text{mm}$
- ▲ Nedtrækskraft 20 kN
- ▲ Tilspændingsmoment 30 Nm

MNG

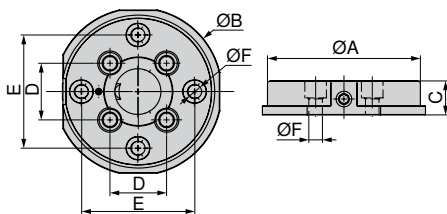

A	B	C _{+0,005}	D	E	F _{H7}	WT
mm	mm	mm	mm	mm	mm	kg
135	148	30	50	100	12	3,5

80 899 ...

DKK
Y4
4.271,00 125

Skruestikguide

Systemtilbehør

144+145 Alment tilbehør

164–183

MNG – Grundplade

- ▲ MNG – Mekanisk Nulpunktsspændesystem
- ▲ Nedtrækskraft 20 kN på hver spændebolt
- ▲ Rustfri og vakuumhærdet
- ▲ Gentagelsesnøjagtighed $\leq 0,01$ mm
- ▲ Tilspændingsmoment 30 Nm

MNG

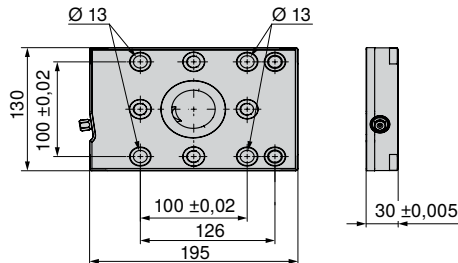

80 899 ...

DKK
Y4

5.251,00 65000

Størrelse	WT
195x130 mm	5,2

MNG – Grundplade 2-fags

- ▲ MNG – Mekanisk Nulpunktsspændesystem
- ▲ Nedtrækskraft 20 kN på hver spændebolt
- ▲ Rustfri og vakuumhærdet
- ▲ Gentagelsesnøjagtighed $\leq 0,01$ mm
- ▲ Tilspændingsmoment 30 Nm

MNG

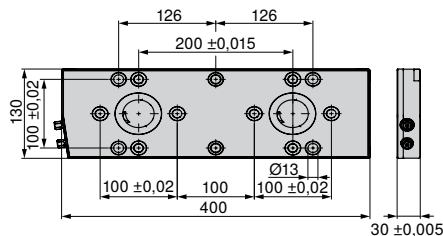

80 899 ...

DKK
Y4

12.342,00 65100

Størrelse	WT
400x130 mm	11

Skruestikguide

Systemtilbehør	144+145	Alment tilbehør	164-183
MNG-opspændingsmuligheder	146-148		

MNG – Grundplade 3-fags

- ▲ MNG – Mekanisk Nulpunktsspændesystem
- ▲ Nedtrækskraft 20 kN på hver spændebolt
- ▲ Rustfri og vakuumhærdet
- ▲ Gentagelsesnøjagtighed $\leq 0,01$ mm
- ▲ Tilspændingsmoment 30 Nm

MNG

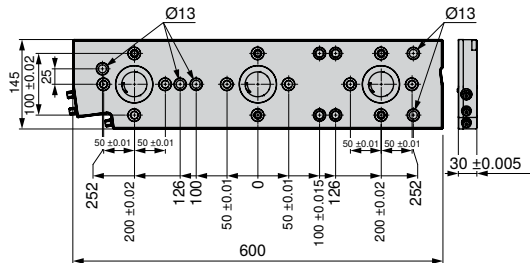

80 899 ...

DKK
Y4

17.503,00 65200

Størrelse	WT
600x145 mm	18 kg

MNG – Grundplade 3-fags, 270 x 190 mm

- ▲ MNG – Mekanisk Nulpunktsspændesystem
- ▲ Nedtrækskraft 20 kN på hver spændebolt
- ▲ 4 x fastgørelseshuller til M12, til T-not afstand 50 mm
- ▲ 8 x pasbøsninger Ø12 F7/M12
- ▲ 4 x pashuller Ø18 H7 til positionering

MNG

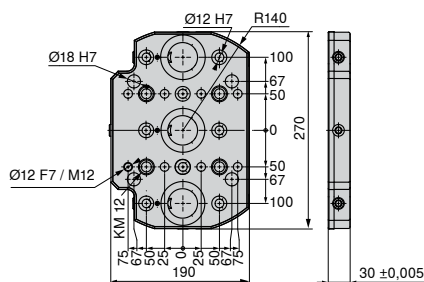

80 899 ...

DKK
Y4

15.783,00 230

Størrelse	WT
270x190 mm	9 kg

Skruestikguide

Systemtilbehør	144+145	Alment tilbehør	164–183
MNG-opspændingsmuligheder	146–148		

MNG – Grundplade 4-fags, 330 x 400 mm

- ▲ MNG – Mekanisk Nulpunktsspændesystem
- ▲ Rustfri og vakuumhærdet
- ▲ Nedtrækskraft 20 kN på hver spændebolt
- ▲ 15 x fastgørelshuller til M12, til T-not afstand 50, 63, 100, 125 mm
- ▲ 13 x pashuller Ø12 F7/M12
- ▲ 2 x fastgørelshuller til M12
- ▲ 2 x pashuller Ø18 G7 til positionering
- ▲ 1 x pashul Ø12 F7 til positionering

MNG

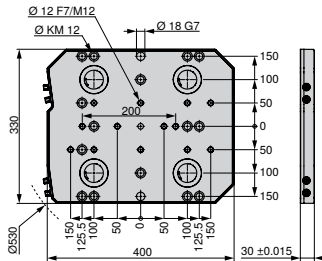

80 899 ...

DKK
Y424.609,00 63000¹⁾

Størrelse WT

330x400 mm 28

1) Ikke på lager

MNG – Grundplade 6-fags, 400 x 400 mm

- ▲ MNG – Mekanisk Nulpunktsspændesystem
- ▲ Rustfri og vakuumhærdet
- ▲ Nedtrækskraft 20 kN på hver spændebolt
- ▲ 14 x fastgørelshuller til M16, til T-not afstand 63, 80, 100, 125 mm
- ▲ 2 x fastgørelshuller til M12
- ▲ 17 x pashuller Ø12 F7/M12
- ▲ 2 x pashuller Ø18 G7 til positionering
- ▲ 1 x pashul Ø12 F7 til positionering

MNG

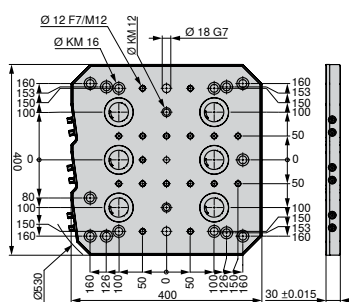

80 899 ...

DKK
Y433.735,00 63100¹⁾

Størrelse WT

400x400 mm 33

1) Ikke på lager

Skruestikguide

Systemtilbehør

144+145 Alment tilbehør

164–183

MNG – Grundplade 6-fags, 400 x 530 mm

- ▲ MNG – Mekanisk Nulpunktsspændesystem
- ▲ Rustfri og vakuumhærdet
- ▲ Nedtrækskraft 20 kN på hver spændebolt
- ▲ 24 x fastgørelseshuller til M12, til T-not afstand 63, 100, 125 mm
- ▲ 21 x pashuller Ø12 F7/M12
- ▲ 2 x pashuller Ø18 G7 til positionering
- ▲ 1 x pashul Ø12 F7 til positionering

MNG

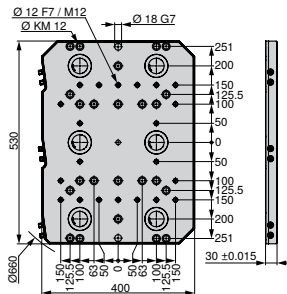

80 899 ...

DKK
Y436.502,00 63200¹⁾

Størrelse	WT kg
400x530 mm	45

1) Ikke på lager

MNG – Grundplade 10-fags, 496,5 x 532 mm

- ▲ MNG – Mekanisk Nulpunktsspændesystem
- ▲ Rustfri og vakuumhærdet
- ▲ Nedtrækskraft 20 kN på hver spændebolt
- ▲ 27 x fastgørelseshuller M12 til T-not afstand 50, 63, 100, 125 mm og stjerneroter 45°
- ▲ 20 x pashuller Ø12 F7/M12
- ▲ 2 x pashuller Ø18 G7 til positionering
- ▲ 1 x pashul Ø12 F7 til positionering

MNG

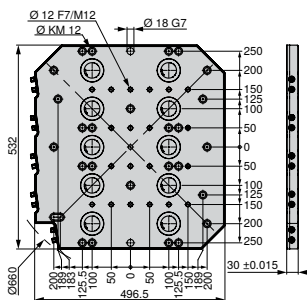

80 899 ...

DKK
Y451.836,00 63300¹⁾

Størrelse	WT kg
497x532 mm	54

1) Ikke på lager

Skruestikguide

Systemtilbehør

144+145 Alment tilbehør

164–183

MNG – Centrertap

▲ MNG – Mekanisk Nulpunktsspændesystem

MNG



80 899 ...

D ₁ n ₆ mm	D ₂ h ₆ mm	DKK Y4	
12	30	554,00	61700
12	32	550,00	61800
12	50	292,00	61900

MNG – Justeringstap

▲ MNG – Mekanisk Nulpunktsspændesystem

MNG



80 899 ...

D ₁ n ₆ mm	D ₂ h ₆ mm	DKK Y4	
18	14	348,00	607
18	18	348,00	608
18	20	460,00	609
18	22	460,00	610

MNG – Opspændingsbolt-sæt til T-not

▲ MNG – Mekanisk Nulpunktsspændesystem

Leveringsomfang:

Opspændingsbolt med T-not møtrik

MNG



80 899 ...

Til notbredde mm	G	DKK Y4	
12	M8	233,00	63800
12	M10	86,00	63400
14	M8	233,00	63900
14	M12	103,00	63500 ¹⁾
16	M8	233,00	64000
16	M12	103,00	63600 ¹⁾
18	M8	233,00	64100
18	M12	103,00	63700 ¹⁾

1) Med skruer med lavt hoved

MNG – Konsol med nulpunktsspændemodul

- ▲ MNG – Mekanisk Nulpunktsspændesystem
- ▲ Universel anvendelse til alle maskinborde
- ▲ Nedtrækskraft 20 kN

Leveringsomfang:

Konsol inklusive MNG spændemodul rund

MNG

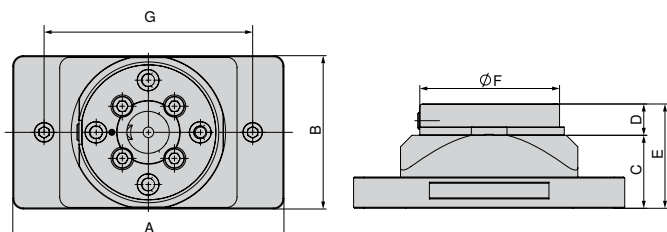

A	B	C	D	E	F	G	WT
mm	mm	mm	mm	mm	mm	mm	kg
260	147	70	30	100	135	200	8,9

80 899 ...

DKK
Y4

8.078,00 425

MNG – Konsol

- ▲ MNG – Mekanisk Nulpunktsspændesystem
- ▲ Universel anvendelse til alle maskinborde
- ▲ Materiale: Aluminium hårdanodiseret

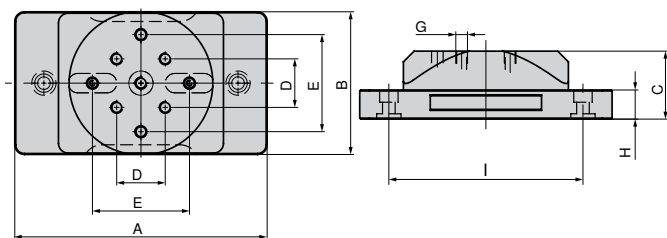

A	B	C	D	E _{±0,02}	G	H	I	WT
mm	mm	mm	mm	mm	M12	mm	mm	kg
260	147	70	50	100	M12	30	200	5,5

80 899 ...

DKK
Y4

3.882,00 420

Skruestikguide

Systemtilbehør

144+145 Alment tilbehør

164–183

MNG – Dobbeltkonsol med nulpunkt spændemodul

- ▲ MNG – Mekanisk Nulpunktsspændesystem
- ▲ Universel anvendelse til alle maskinborde
- ▲ Materiale: Aluminium hårdanodiseret

Leveringsomfang:

Konsol inklusive MNG spændemodul rund

MNG

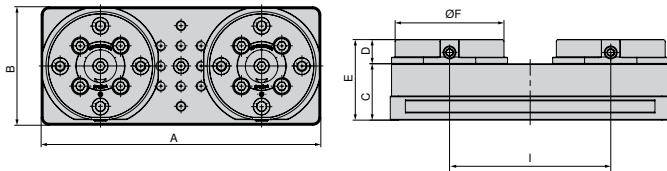

A	B	C	D	E	F	I	WT
mm	mm	mm	mm	mm	mm	mm	kg
347	147	70	30	100	135	200	16,5

80 899 ...

DKK
Y4

14.586,00 435

MNG – Dobbeltkonsol

- ▲ MNG – Mekanisk Nulpunktsspændesystem
- ▲ Universel anvendelse til alle maskinborde
- ▲ Materiale: Aluminium hårdanodiseret

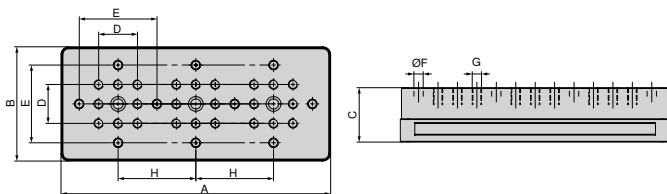

A	B	C	D	E ±0,02	F F7	G	H	WT
mm	mm	mm	mm	mm	mm	M12	mm	kg
347	147	70	50	100	12	M12	100	9,3

80 899 ...

DKK
Y4

5.303,00 430

Skruestikguide

Systemtilbehør

144+145 Alment tilbehør

164–183

MNG – Konsol med nulpunkt spændemodul

▲ MNG – Mekanisk Nulpunktsspændesystem

MNG

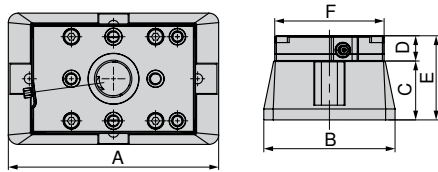

A	B	C	D	E	F
mm	mm	mm	mm	mm	mm
250	156	70	30	100	130

80 878 ...

DKK
Y4

9.724,00 54000

Konsol

▲ MNG – Mekanisk Nulpunktsspændesystem

ZSG
4

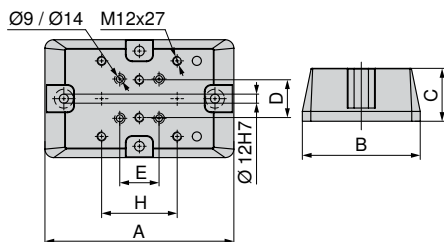

A	B	C	D	E	H	til
mm	mm	mm	mm	mm	mm	
250	156	70	50	52	100	ZSG 4 - 80 L = 130 mm + 190 mm / ZSG 4 - 125 L = 160 mm
320	197	100	50	50	100	ZSG 4 - 160 L = 280 mm
340	162	100	50	50	100	ZSG 4 - 125 L = 235 mm / 300 mm

80 878 ...

DKK
Y4

4.286,00 54100

6.754,00 54400

6.732,00 54300

MNG – Montagesæt til konsol

▲ MNG – Mekanisk Nulpunktsspændesystem



til
ZSG-4.125/160.L235-L280
ZSG-4.80.L130-L190

80 878 ...

DKK
Y4

85,00 54500

85,00 54200

Skruestikguide

Systemtilbehør

144+145 Alment tilbehør

164-183

MNG – Aluminium formspændetang

- ▲ MNG – Mekanisk Nulpunktsspændesystem
- ▲ Til indarbejdning af forme til 2-sidet bearbejdning

Leveringsomfang:

Spændetang med positioneringsstifter, uden bolte

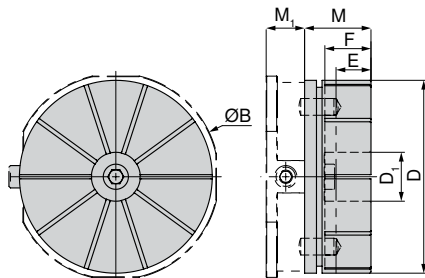

B	D	D ₁	E	F	M	M ₁
mm	mm	mm	mm	mm	mm	mm
148	138	35	22	33	47,5	27,5

80 899 ...

DKK
Y4

1.795,00 500



Alu-spændetang med indarbejdet emneform til MNG rund



Alu-spændetang med opspændt emne på MNG rund

Fås på forespørgsel



Palette med huller



Blank palette

 Den maksimale udfræsningsdybde E er 22 mm

Justeringsring til MNG formspændetang

MNG



80 899 ...

DKK
Y4

436,00 510

Skruestikguide

Systemtilbehør

144+145 Alment tilbehør

164–183

MNG – antræksbolt

▲ MNG – Mekanisk Nulpunktsspændesystem

Leveringsomfang:

Inkl. fastspændingsbolte

MNG

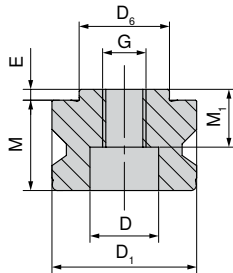

D ₆ h6	D ₁ h6	M	M ₁	E	D	G
mm	mm	mm	mm	mm	mm	
25	40	27	17	3	19	M12

80 899 ...

DKK

Y4

364,00

025

MNG – Blindprop

▲ MNG – Mekanisk Nulpunktsspændesystem

MNG

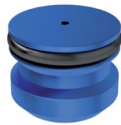

D ₁
mm
40

80 899 ...

DKK

Y4

107,00

040

MNG – cylinderstiftsæt

▲ MNG – Mekanisk Nulpunktsspændesystem

▲ Til ESG mini 4V tårn og direkte opspænding af emne

▲ Pris pr. 2 stk.

MNG



D ₁ m6	M
mm	mm
12	24

80 899 ...

DKK

Y4

18,00

120

MNG – Blindprop med O-ring

▲ MNG – Mekanisk Nulpunktsspændesystem

MNG



G
M12

80 899 ...

DKK

Y4

18,00

126

MNG – positioneringsstiftsæt

▲ MNG – Mekanisk Nulpunktsspændesystem

▲ Til ESG mini og direkte opspænding af emne

▲ Pris pr. 2 stk.

MNG

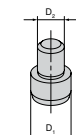

Til bredde	D ₁	D ₂
mm	mm	mm
65	12	8

80 899 ...

DKK

Y4

260,00

128

MNG – positioneringsstift

▲ MNG – Mekanisk Nulpunktsspændesystem

MNG

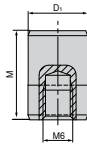

D ₁ mm	M mm
12	18

80 899 ...
DKK
Y4
129,00 51500

MNG – Opspændingsbolt-sæt til T-not

▲ MNG – Mekanisk Nulpunktsspændesystem

Leveringsomfang:

Opspændingsbolt med T-not møtrik

MNG



Til notbredde mm	G	DKK Y4	80 899 ...
12	M8	233,00	63800
12	M10	86,00	63400
14	M8	233,00	63900
14	M12	103,00	63500 ¹⁾
16	M8	233,00	64000
16	M12	103,00	63600 ¹⁾
18	M8	233,00	64100
18	M12	103,00	63700 ¹⁾

1) Med skruer med lavt hoved

MNG – Opspændings-sæt til 14 mm T-not

▲ MNG – Mekanisk Nulpunktsspændesystem

▲ T-notmøtrikkerne er modificeret til 63 mm not-afstand

▲ Pris pr. 2 stk.

MNG



Til notbredde mm	A mm
14	63

80 899 ...
DKK
Y4
719,00 614

MNG – Justerings-/centrersæt til T-noter

▲ MNG – Mekanisk Nulpunktsspændesystem

▲ A = Not afstand

Leveringsomfang:

1 klemliste, 2 T-not møtrikker, 2 skruer, 2 underlagsskiver til bredde 12 mm, uden klemliste!

MNG



A mm	Til notbredde mm	DKK Y4	80 899 ...
50	12	533,00	012 ¹⁾
50	14	533,00	014
50	16	533,00	016
50	18	533,00	018
100	12	702,00	81200
100	14	702,00	81400
100	16	702,00	81600
100	18	702,00	81800

1) Til bredde 12 mm uden klemliste

MNG – Rund spændejern

▲ MNG – Mekanisk Nulpunktsspændesystem

▲ Sæt a 2 stk.

▲ Pris pr. 2 stk.

MNG



80 899 ...
DKK
Y4
606,00 300

MNG – Reserve spændeenhed

▲ MNG – Mekanisk Nulpunktsspændesystem

▲ Sæt a 3 dele

▲ Til MNG rund

MNG



80 899 ...
DKK
Y4
942,00 026

MNG

MNG-opspændingsmuligheder

MNG – Grundplade

Fastgørelse:

- 2 x M12-skruer med lavt hoved
- 1 x Juster- og centreringssæt

→ Side 148
Her finder du passende bolte.

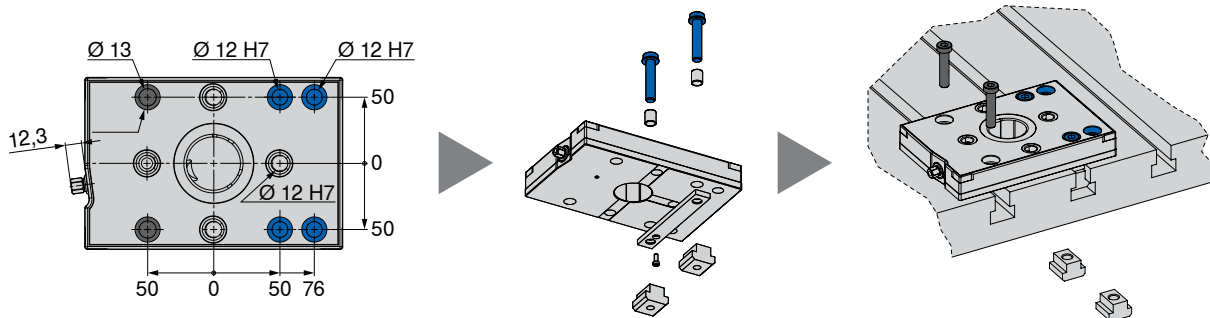

MNG – Grundplade 2-delt

Fastgørelse:

- 4 x M12-skruer med lavt hoved
- 1 x Juster- og centreringssæt
- 4 x M8-MNG-specialskruer

→ Side 148
Her finder du passende bolte.

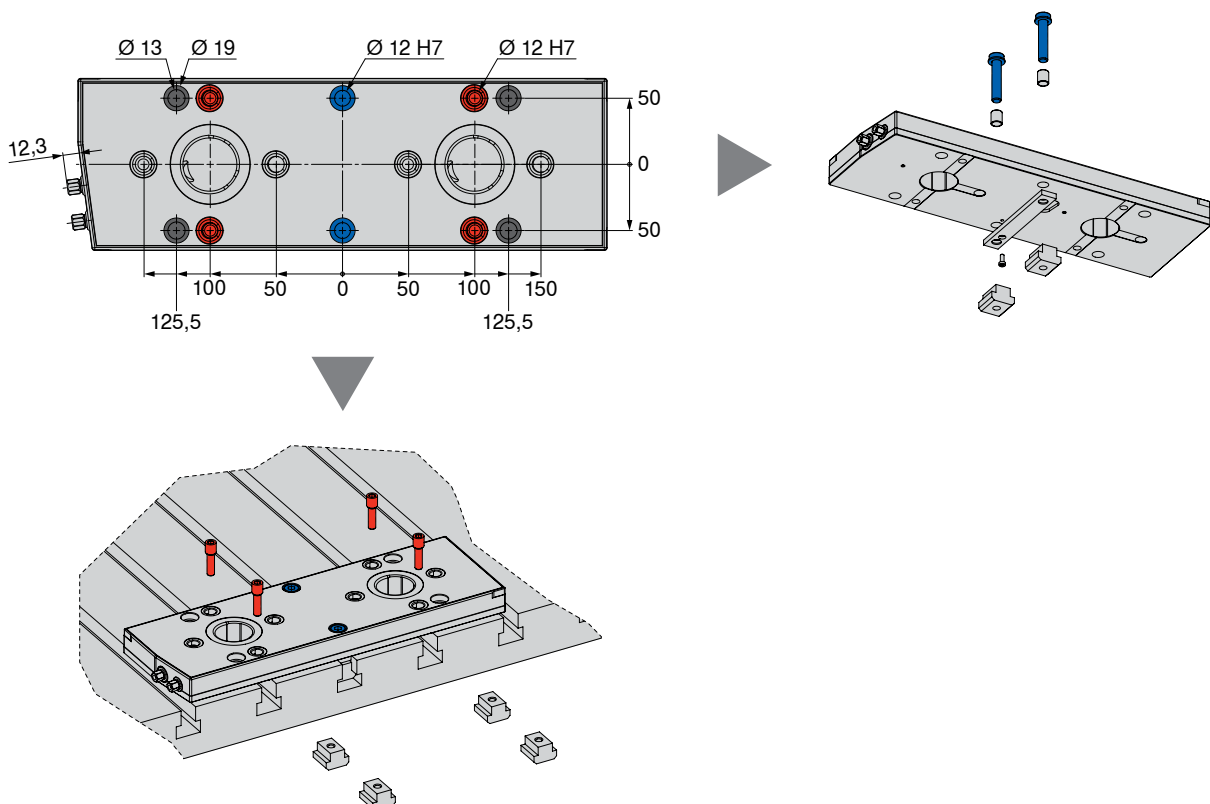

MNG-opspændingsmuligheder

MNG – Grundplade 3-delt

Fastgørelse:

- 5 x M12-skruer med lavt hoved
- 1 x Juster- og centreringssæt
- 5 x M8-MNG-specialskruer



→ Side 148
Her finder du passende bolte.

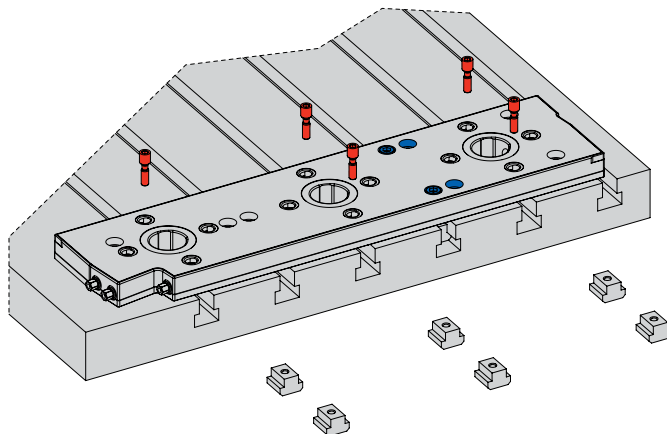
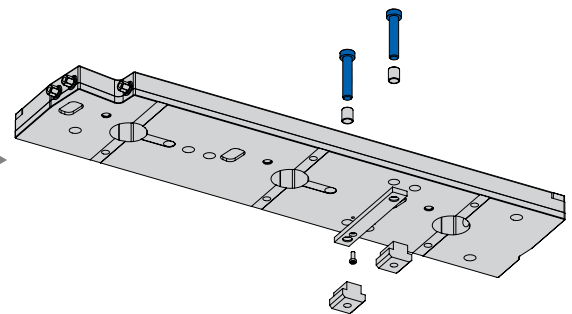
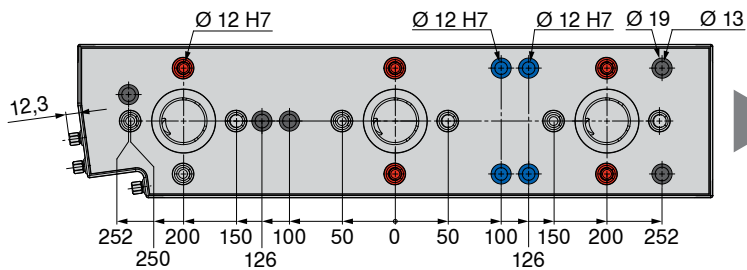

MNG-opspændingsmuligheder

T-not-bord – afstand 126 mm/63 mm												
	12 mm			14 mm			16 mm			18 mm		
	●	●	●	●	●	●	●	●	●	●	●	
	Juster- og centreringssæt afstand 100 mm 80 899 81200	Opspændingssæt med M10-skruer med lavt hoved 80 899 63400	Opspændingssæt med M8-MNG-specialskruer 80 899 63800	Juster- og centreringssæt afstand 100 mm 80 899 81400	Opspændingssæt med M12-skruer med lavt hoved 80 899 63500	Opspændingssæt med M8-MNG-specialskruer 80 899 63900	Juster- og centreringssæt afstand 100 mm 80 899 81600	Opspændingssæt med M12-skruer med lavt hoved 80 899 63600	Opspændingssæt med M8-MNG-specialskruer 80 899 64000	Juster- og centreringssæt afstand 100 mm 80 899 81800	Opspændingssæt med M12-skruer med lavt hoved 80 899 63700	Opspændingssæt med M8-MNG-specialskruer 80 899 64100
MNG – Grundplade	1 x	2 x	—	1 x	2 x	—	1 x	2 x	—	1 x	2 x	—
MNG – Grundplade 2-delt	1 x	4 x	—	1 x	4 x	—	1 x	4 x	—	1 x	4 x	—
MNG – Grundplade 3-delt	1 x	4 x	2 x	1 x	4 x	2 x	1 x	4 x	2 x	1 x	4 x	2 x

T-not-bord – afstand 100 mm/50 mm												
	12 mm			14 mm			16 mm			18 mm		
	●	●	●	●	●	●	●	●	●	●	●	
	Juster- og centreringssæt afstand 100 mm 80 899 81200	Opspændingssæt med M10-skruer med lavt hoved 80 899 63400	Opspændingssæt med M8-MNG-specialskruer 80 899 63800	Juster- og centreringssæt afstand 100 mm 80 899 81400	Opspændingssæt med M12-skruer med lavt hoved 80 899 63500	Opspændingssæt med M8-MNG-specialskruer 80 899 63900	Juster- og centreringssæt afstand 100 mm 80 899 81600	Opspændingssæt med M12-skruer med lavt hoved 80 899 63600	Opspændingssæt med M8-MNG-specialskruer 80 899 64000	Juster- og centreringssæt afstand 100 mm 80 899 81800	Opspændingssæt med M12-skruer med lavt hoved 80 899 63700	Opspændingssæt med M8-MNG-specialskruer 80 899 64100
MNG – Grundplade	1 x	2 x	—	1 x	2 x	—	1 x	2 x	—	1 x	2 x	—
MNG – Grundplade 2-delt	1 x	—	4 x	1 x	—	4 x	1 x	—	4 x	1 x	—	4 x
MNG – Grundplade 3-delt	1 x	1 x	5 x	1 x	1 x	5 x	1 x	1 x	5 x	1 x	1 x	5 x

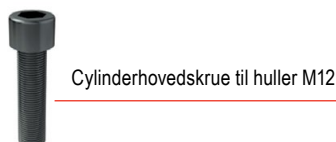
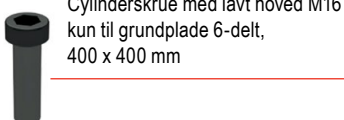
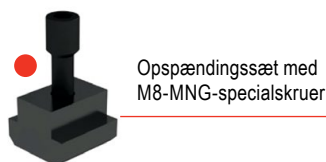

→ Side 145
→ Side 182+183

Her finder du de artikler, der er vist ovenfor.

MNG mini – Konsol

- ▲ med integreret MNG mini nulpunktspændesystem
- ▲ Monteringsbolte skal bestilles separat
- ▲ Materiale: Aluminium, hårdanodiseret

MNG
mini

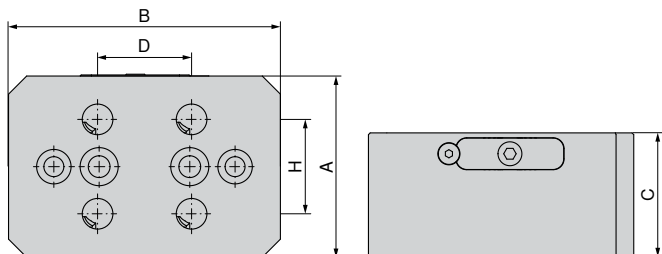

NEW

80 915 ...

DKK
Y4

5.760,00 57000

A	B	C	D	H
mm	mm	mm	mm	mm
100	150	70	52	52

MNG mini – Pyramide, 3-delt

- ▲ inkl. 3 x MNG mini nulpunktspændesystem
- ▲ Monteringsbolte skal bestilles separat
- ▲ Materiale: Aluminium, hårdanodiseret

MNG
mini

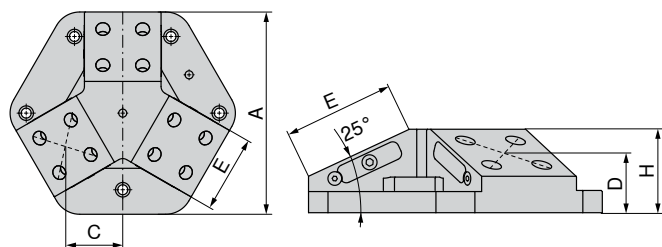

NEW

80 915 ...

DKK
Y4

14.810,00 58000

A	C	D	E	H
mm	mm	mm	mm	mm
264	86,68	53,87	100	75

 Eget til: ESG 5 – 80 L-130 / ZSG 4 – 80 L-130 / ZSG mini – 70 L-80 / ZSG mini – 70 L-100

MNG mini dimensioner

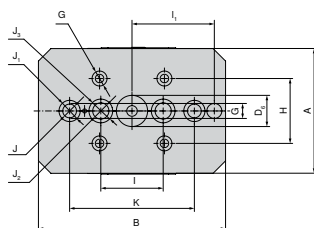

Konsol

A	B	D ₆ H7	G H7	H	I	I ₁ ±0.015	J	J ₁	J ₂	J ₃	K ±0.015
mm	mm	mm	mm	mm	mm	mm	mm	mm	mm	mm	mm
100	150	25	12	52	50	66	11	17	13	19	100

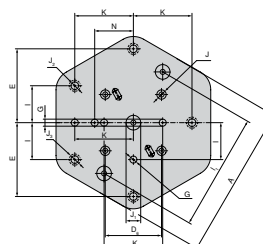

Pyramide, 3-delt

A	D ₆ ±0.015	E	G H7	I	I ₁ ±0.015	J H7	J ₁ H7	J ₂	J ₃	K	N ±0.015
mm	mm	mm	mm	mm	mm	mm	mm	mm	mm	mm	mm
264	96	126	12	63	200	16	25	13	19	100	66

MNG mini – Pyramide, 4-delt

- ▲ inkl. 4 x MNG mini nulpunktspændesystem
- ▲ Monteringsbolte skal bestilles separat
- ▲ Materiale: Aluminium, hårdanodiseret

MNG mini

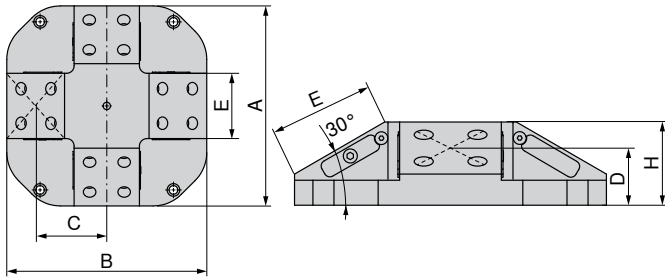

NEW

80 915 ...

DKK
Y4

17.877,00 57500

A	B	C	D	E	H
mm	mm	mm	mm	mm	mm
300	300	106,7	55	100	80

MNG mini – Trekantet opspændingstårn

- ▲ inkl. 3 x MNG mini nulpunktspændesystem
- ▲ Monteringsbolte skal bestilles separat
- ▲ Materiale: Aluminium, hårdanodiseret

MNG mini

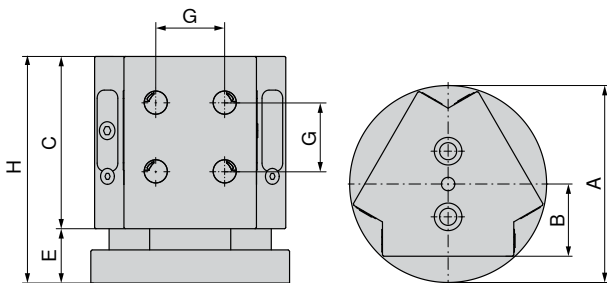

NEW

80 915 ...

DKK
Y4

11.145,00 51700

A	B	C	E	G	H
mm	mm	mm	mm	mm	mm
148	55	130	41	52	171

 Egnet til: ESG 5 – 80 L-130 / ZSG 4 – 80 L-130 / ZSG mini – 70 L-80 / ZSG mini – 70 L-100

MNG mini dimensioner

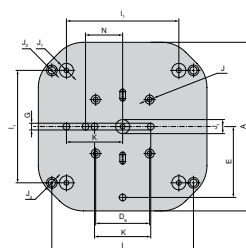

Pyramide, 4-delt

A	D ₆ ±0.015	E	G _{H7}	I	I ₁ ±0.015	J _{H7}	J _{1H7}	J ₂	J ₃	K ±0.015	N ±0.015
mm	mm	mm	mm	mm	mm	mm	mm	mm	mm	mm	mm
300	96	126	12	252	200	16	25	13	19	100	66

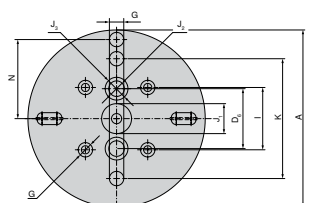

Trekantet opspændingstårn

A	D ₆	G _{H7}	I ±0.015	J _{1H7}	J ₂	J ₃	K ±0.015	N ±0.015
mm	mm	mm	mm	mm	mm	mm	mm	mm
148	50	12	52	25	13	19	100	66

Monteringsboltesæt MNG mini

Leveringsomfang:

Sættet indeholder fire monteringsbolte

**MNG
mini**

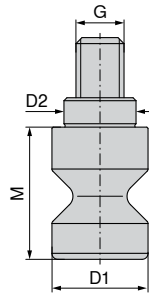

NEW

80 915 ...

DKK
Y4

501,00 51600

D ₁ h6	D ₂ h6	M	G	TQX	Holdestyrke
mm	mm	mm	mm	Nm	kN
16	12	22	M8	18	15

Opspændingsbolt-sæt til T-not til MNG mini

Leveringsomfang:

Opspændingsbolt med T-not møtrik

**MNG
mini**



NEW

80 915 ...

DKK
Y4

125,00 61200
125,00 61400
134,00 61600
142,00 61800

Til notbredde mm	G
12	M10
14	M12
16	M12
18	M12

Justerings-/centrersæt til T-noter

▲ MNG – Mekanisk Nulpunktsspændesystem

▲ A = Not afstand

Leveringsomfang:

1 klemme, 2 T-not møtrikker, 2 skruer, 2 underlagsskiver til bredde 12 mm, uden klemme!

**MNG
mini**



NEW

80 915 ...

DKK
Y4

678,00 81200
678,00 81400
678,00 81600
678,00 81800

A mm	Til notbredde mm
100	12
100	14
100	16
100	18

PNG – Spændestation, 1-fags

- ▲ PNG – pneumatisk nulpunkt-spændesystem
- ▲ Nedtrækskraft 8 kN
- ▲ Nedtrækskraft med turbo 28 kN
- ▲ Frigørelsestryk 6 bar
- ▲ Lufttilslutning G 1/8

Leveringsomfang:

Spændestation, fastgørelsesklemmer, lukkenippel, pneumatiske stiktilslutninger, støvbeskyttelseskapper, betjeningsvejledning, uden spændebolte, uden positioneringsstifte

PNG

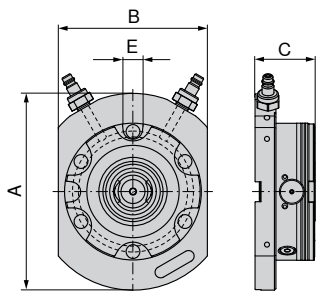

A	B	C	E _{H7}	WT
mm	mm	mm	mm	kg
198	150	60	20	7

80 809 ...

DKK
Y4

11.220,00 01100

PNG – Spændestation 2-fags, 399 x 199 mm

- ▲ PNG – pneumatisk nulpunkt-spændesystem
- ▲ Nedtrækskraft 16 kN
- ▲ Frigørelsestryk 6 bar
- ▲ Lufttilslutning G 1/8

Leveringsomfang:

Spændestation, fastgørelsesklemmer, lukkenippel, pneumatiske stiktilslutninger, støvbeskyttelseskapper, betjeningsvejledning, uden spændebolte, uden positioneringsstifte

PNG

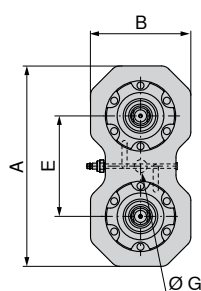

A	B	C	E	G _{H7}	WT
mm	mm	mm	mm	mm	kg
399	199	60	200	25	16,9

80 809 ...

DKK
Y4

17.952,00 02100

PNG – Spændestation 4-fags, 399 x 399 mm

- ▲ PNG – pneumatisk nulpunkt-spændesystem
- ▲ Nedtrækskraft 32 kN
- ▲ Sliptryk 6 bar
- ▲ Lufttilslutning G 1/8

Leveringsomfang:

Spændestation, fastgørelsesklemmer, lukkenippel, pneumatiske stiktilslutninger, støvbeskyttelseskapper, betjeningsvejledning, uden spændebolte, uden positioneringsstifte

PNG

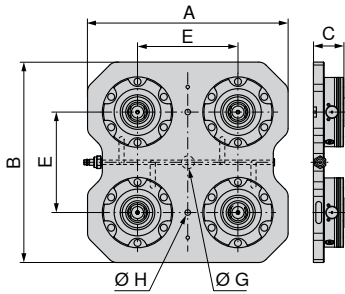

A	B	C	E	G _{H7}	H	WT
mm	mm	mm	mm	mm	mm	kg
399	399	60	200	25	11	35,7

80 809 ...

DKK
Y4

34.632,00 04100

PNG – Spændestation 6-fags, 599 x 399 mm

- ▲ PNG – pneumatisk nulpunkt-spændesystem
- ▲ Nedtrækskraft 48 kN
- ▲ Frigørelsestryk 6 bar
- ▲ Lufttilslutning G 1/8

Leveringsomfang:

Spændestation, fastgørelsesklemmer, lukkenippel, pneumatiske stiktilslutninger, støvbeskyttelseskapper, betjeningsvejledning, uden spændebolte, uden positioneringsstifte

PNG

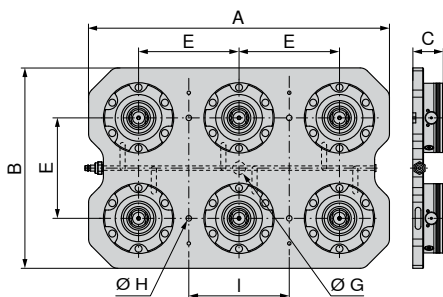

A	B	C	E	G _{H7}	H	I	WT
mm	mm	mm	mm	mm	mm	mm	kg
599	399	60	200	25	11	200	54,4

80 809 ...

DKK
Y4

46.675,00 06100

PNG – Nulpunkt-spændemodul PNG.SM.138

- ▲ PNG – pneumatisk nulpunkt-spændesystem
- ▲ Nedtrækskraft 8 kN
- ▲ Nedtrækskraft med turbo 28 kN
- ▲ Oplåsningstryk 6 bar
- ▲ Lufttilslutning G 1/8
- ▲ Gentagelsesnøjagtighed 0,005

Leveringsomfang:

Spændemodul, fastgørelsesskruer, O-ringe, dækkapper, betjeningsvejledning, uden spændebolte

PNG

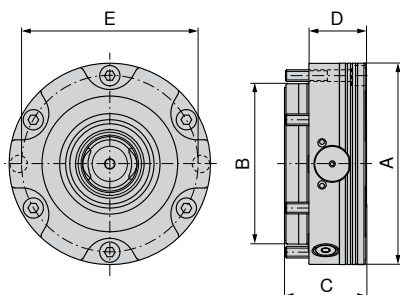

A	B	C	D	E	G	WT
mm	mm	mm	mm	mm		kg
138	110	55,7	39	121	G1/8"	4,4

80 809 ...

DKK
Y4

7.136,00 10100

PNG – Nulpunkt-spændemodul PNG.SM.T.138

- ▲ PNG – pneumatisk nulpunkt-spændesystem
- ▲ Nedtrækskraft 7 kN
- ▲ Nedtrækskraft med turbo 24 kN
- ▲ Frigørelsestryk 6 bar
- ▲ Lufttilslutning G 1/8
- ▲ Gentagelsesnøjagtighed 0,005

Leveringsomfang:

Spændemodul, fastgørelsesskruer, O-ringe, dækkapper, betjeningsvejledning, uden positioneringsstifte

PNG

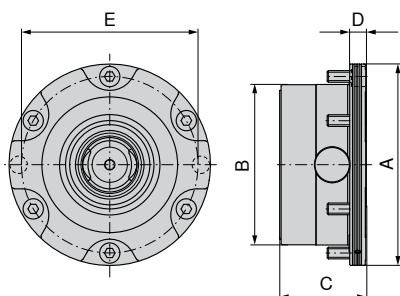

A	B	C	D	E	G	WT
mm	mm	mm	mm	mm		kg
138	110	59	11	121	G1/8"	3,5

80 809 ...

DKK
Y4

7.779,00 12100

PNG – Nulpunkt-spændemodul PNG.SM.V.138

- ▲ PNG – pneumatisk nulpunkt-spændesystem
- ▲ Nedtrækskraft 8 kN
- ▲ Nedtrækskraft med turbo 28 kN
- ▲ Frigørelsestryk 6 bar
- ▲ Lufttilslutning G 1/8
- ▲ Gentagelsesnøjagtighed 0,005

Leveringsomfang:

Spændemodul, fastgørelsesskruer, passkrue, O-ringe, dækkapper, betjeningsvejledning, uden spændebolte, uden indekseringsbolte

PNG

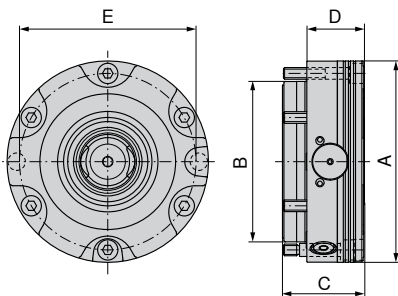

A	B	C	D	E	G	WT
mm	mm	mm	mm	mm		kg
138	110	55,7	39	121	G1/8"	4,4

80 809 ...

DKK
Y4

7.630,00 11100

PNG – Aluminium formspændetang

- ▲ PNG – pneumatisk nulpunkt-spændesystem
- ▲ Maks. spændkraft 50 kN
- ▲ Gentagelsesnøjagtighed 0,005
- ▲ Spændeslag 0,5 mm
- ▲ Materiale aluminium

Leveringsomfang:

Aluminium-formspændetang, justeringsring, antræksbolt, positioneringsstift, driftsvejledning

PNG

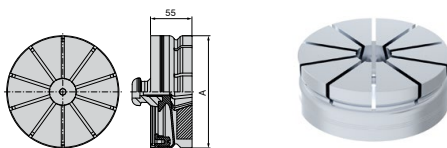

A	WT
mm	kg
149	1,5

80 809 ...

DKK
Y4

2.424,00 07600

PNG – positioneringsstift

- ▲ PNG – pneumatisk nulpunkt-spændesystem

PNG

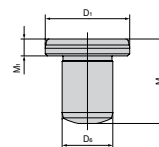

D ₁ h5	M	M ₁	D ₂ m6
mm	mm	mm	mm
20	20	4	12

80 809 ...

DKK
Y4

391,00 073

Montage – spændebolt

De emner eller enheder, der skal monteres, positioneres og fastgøres ved hjælp af tre forskellige spændebolte:



Centreringsbolt

Præcisionslebet, benyttes til præcis positionering af spændeanordningen.



Positioneringsbolt

Denne bolt, der også betegnes diamantbolt, slibes kun i aksial retning, så systemet ikke overbelastes.



Klemmebolt

Sørger for, at paletterne ligger fladt på spændesystemet, mindre slebet på kort konus.

PNG – antræksbolte

- ▲ PNG – pneumatisk nulpunkt-spændesystem
- ▲ 3 bolttyper – ZB (centerbolt), PB (positioneringsbolt), HB (holdebolt)
- ▲ Højpræcis tilpasning af målene til funktionen
- ▲ Holdekraft 50 kN

Leveringsomfang:

Inkl. fastgørelsesskrue M10

PNG

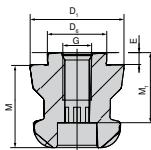

80 809 ...

Type	D ₆ H6 mm	D ₁ h6 mm	M mm	M ₁ mm	E mm	G	DKK Y4	
ZB	25	40	35	27	5	M12	429,00	070
PB	25	40	35	27	5	M12	517,00	071
HB	25	40	35	27	5	M12	390,00	072

PNG – Konuslukning

- ▲ PNG – pneumatisk nulpunkt-spændesystem
- ▲ Effektiv afskærmning af spændemodul

PNG

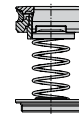

80 809 ...

WT
kg
0,11

DKK
Y4
905,00 07500

PNG – afskærmning

- ▲ PNG – pneumatisk nulpunkt-spændesystem
- ▲ Effektiv afskærmning af spændemodul

PNG

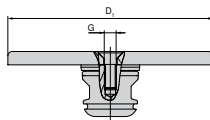

80 809 ...

D ₁ mm	G	DKK Y4	
138	M8	710,00	074

Oversigt multiadapterpaletter



Multiadapterpalette 159 x 159 mm

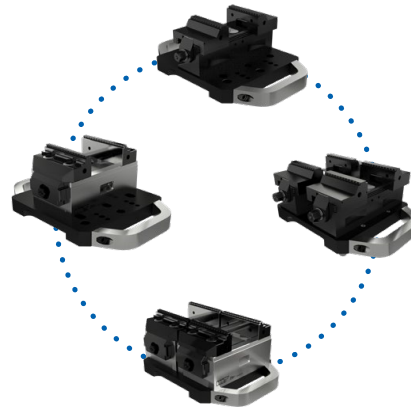

Eksempler på anvendelse

Multiadapterpalette, 159 x 159 mm

▲ Multiadapterpalette til fastgørelse på PNG og MNG

Leveringsomfang:

Inkl. spændebolt og spændeskruer
Uden antræksbolte

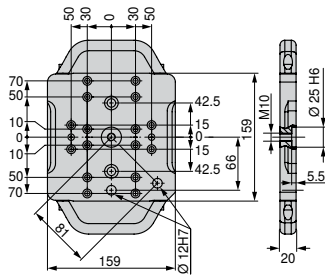

Størrelse	WT	80 809 ...
159x159 mm	4 kg	DKK Y4 3.755,00 500

Montagesæt – multiadapterpalette, 159 x 159 mm

▲ Pris pr. sæt



til	80 878 ...
ZSG-4.80	DKK Y4 129,00 503

Oversigt multiadapterpaletter



Multiadapterpalette 399 x 159 mm

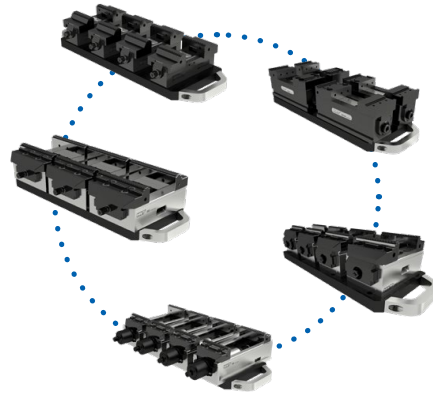

Eksempler på anvendelse

Multiadapterpalette, 399 x 159 mm

▲ Multiadapterpalette til fastgørelse på PNG og MNG

Leveringsomfang:

Inkl. spændebolt og spændeskruer
Uden antræksbolte

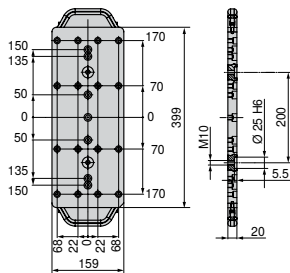

Størrelse	WT
399x159 mm	10 kg

80 809 ...
DKK
Y4
5.513,00 501

Montagesæt – multiadapterpalette, 399 x 159 mm

▲ Pris pr. sæt



til
ZSG-3.65/ZSG-4.80/125L160/ESG-4.80

80 884 ...
DKK
Y4
292,00 503

Oversigt multiadapterpaletter

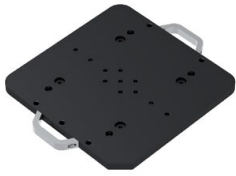

Multiadapterpalette 399 x 399 mm

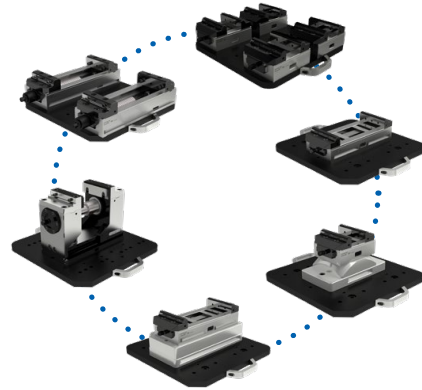

Eksempler på anvendelse

Multiadapterpalette, 399 x 399 mm

▲ Multiadapterpalette til fastgørelse på PNG og MNG

Leveringsomfang:

Inkl. spændebolt og spændeskruer
Uden antræksbolte

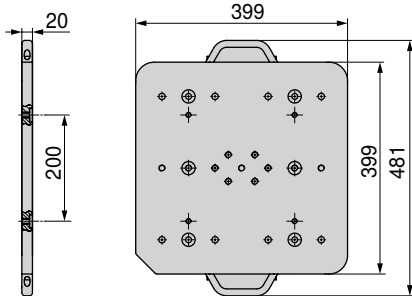

Størrelse	WT	80 809 ...
399x399 mm	25 kg	DKK Y4 10.322,00 502

Montagesæt – multiadapterpalette, 399 x 399 mm

▲ Pris pr. sæt



til	80 901 ...	80 898 ...	80 878 ...
	DKK Y4	DKK Y4	DKK Y4
ESG4.125	412,00 500		
H5G.125		412,00 500	
ZSG-4.125.L160			129,00 500
ZSG-4.125.L160.K			412,00 502
ZSG-4.125.L300			412,00 501
ZSG-4.125.L300-DK			412,00 504

Spændepalette stål, 159 x 159 mm

- ▲ Spændepalette til fastgørelse på PNG
- ▲ Uden hulmønster

Leveringsomfang:

Spændepalette PNG-antræksbolt og positioneringsstift

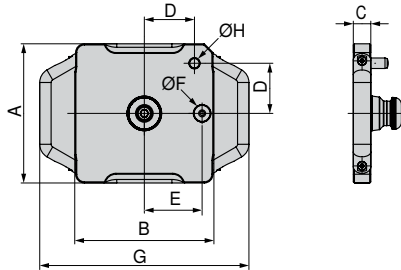

Størrelse	A	B	C	D	E	F _{H5}	G	H _{M6}	WT
	mm	mm	mm	mm	mm	mm	mm	mm	kg
159x159 mm	159	159	20	58	66	20	239	12	4,2

80 809 ...

DKK
Y4

2.491,00 080

Spændepalette aluminium, 159 x 159 mm

- ▲ Spændepalette til fastgørelse på PNG
- ▲ Uden hulmønster

Leveringsomfang:

Spændepalette PNG-antræksbolt og positioneringsstift

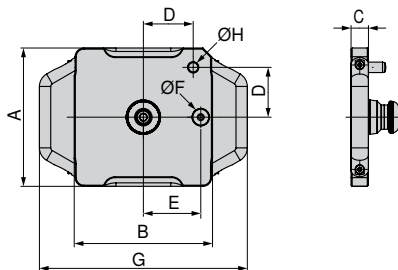

Størrelse	A	B	C	D	E	F _{H5}	G	H _{M6}	WT
	mm	mm	mm	mm	mm	mm	mm	mm	kg
159x159 mm	159	159	25	58	66	20	239	12	2,2

80 809 ...

DKK
Y4

2.812,00 081

Spændepalette stål, 399 x 159 mm

- ▲ Spændepalette til fastgørelse på PNG og MNG
- ▲ Uden hulmønster

Leveringsomfang:

Spændepalette PNG-antræksbolt og positioneringsstift

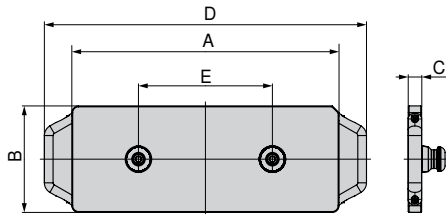

Størrelse	A mm	B mm	C mm	D mm	E mm	WT kg
399x159 mm	399	159	20	481	200	10,6

80 809 ...

DKK
Y4

4.997,00 082

Spændepalette aluminium, 399 x 159 mm

- ▲ Spændepalette til fastgørelse på PNG og MNG
- ▲ Uden hulmønster

Leveringsomfang:

Spændepalette PNG-antræksbolt og positioneringsstift

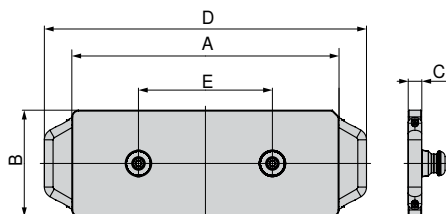

Størrelse	A mm	B mm	C mm	D mm	E mm	WT kg
399x159 mm	399	159	25	481	200	5,1

80 809 ...

DKK
Y4

4.368,00 083

Spændepalette stål, 399 x 399 mm

- ▲ Spændepalette til fastgørelse på PNG og MNG
- ▲ Uden hulmønster

Leveringsomfang:

Spændepalette PNG-antræksbolt og positioneringsstift

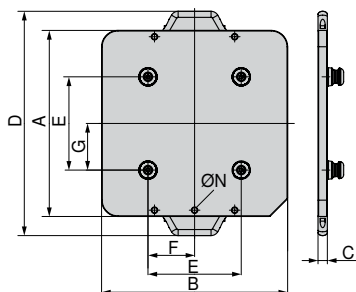

Størrelse	A	B	C	D	E	F	G	N	WT
	mm	mm	mm	mm	mm	mm	mm	M10	kg
399x399 mm	399	399	20	481	200	100	100	M10	28

80 809 ...

DKK
Y4

10.921,00 084

Spændepalette aluminium, 399 x 399 mm

- ▲ Spændepalette til fastgørelse på PNG og MNG
- ▲ Uden hulmønster

Leveringsomfang:

Spændepalette PNG-antræksbolt og positioneringsstift

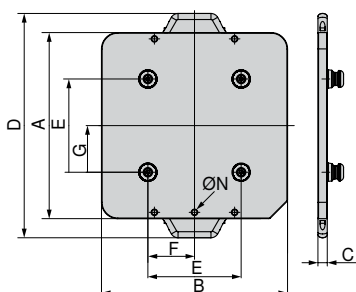

Størrelse	A	B	C	D	E	F	G	N	WT
	mm	mm	mm	mm	mm	mm	mm	M10	kg
399x399 mm	399	399	25	481	200	100	100	M10	12

80 809 ...

DKK
Y4

8.004,00 085

Spændepalette stål, 599 x 159 mm

- ▲ Spændepalette til fastgørelse på PNG og MNG
- ▲ Uden hulmønster

Leveringsomfang:

Spændepalette PNG-antræksbolt og positioneringsstift

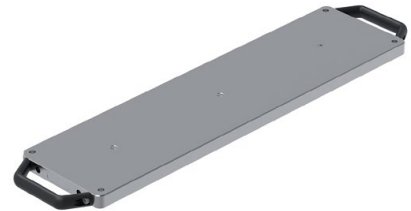
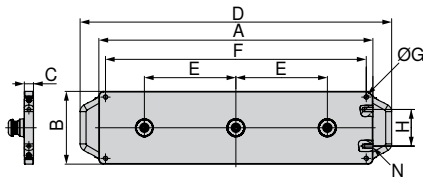

Størrelse	A	B	C	D	E	F	G	H	N	WT
	mm	mm	mm	mm	mm	mm		mm		kg
599x159 mm	599	159	20	681	200	570	M10	80	M10	15,6

80 809 ...

DKK
Y4

7.001,00 086

Spændepalette aluminium, 599 x 159 mm

- ▲ Spændepalette til fastgørelse på PNG og MNG
- ▲ Uden hulmønster

Leveringsomfang:

Spændepalette PNG-antræksbolt og positioneringsstift

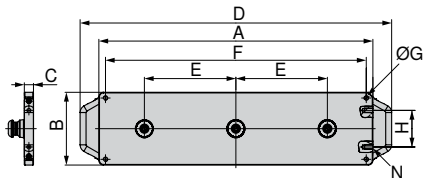

Størrelse	A	B	C	D	E	F	G	H	N	WT
	mm	mm	mm	mm	mm	mm		mm		kg
599x159 mm	599	159	25	681	200	570	M10	80	M10	7,4

80 809 ...

DKK
Y4

7.630,00 087

Oversigt almene topbakker

6-fags vendebakke

- ▲ 1 = Glat, Wolfram-Carbide belagt
- ▲ 2 = Grip med trin 3 mm
- ▲ 3 = Grip med trin 8 mm
- ▲ 4 = Grip med trin 18 mm
- ▲ 5 = Grip rund med trin 8 mm
- ▲ 6 = Grip rund
- ▲ $M_{max} = 60 \text{ Nm}$
- ▲ Inkl. fastspændingsbolte

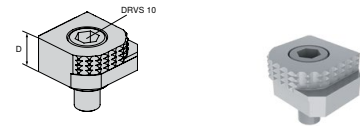

Til skruestikbredde	A	A ₁	D	D ₁	D ₂	E	M	M ₁	M ₂	DKK	Y4	NCG	H5G / -S / -Z	X5G-Z / -S	ESG 4	ESG 5	HDG 2	ZSG 4	ZSG mini	DSG 4	Verso	HSG	
			18							603,00	80 892 246	●	●	●	●				●	●	●	●	

6-fags vendebakke, Carbide grip

- ▲ 1 = Glat
- ▲ 2 = Carbide grip
- ▲ 3 = Carbide grip med trin 3 mm
- ▲ 4 = Carbide grip med trin 8 mm
- ▲ 5 = Carbide grip rund med trin 8 mm
- ▲ 6 = Carbide grip rund
- ▲ Inkl. fastspændingsbolte

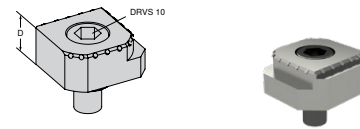

Til skruestikbredde	A	A ₁	D	D ₁	D ₂	E	M	M ₁	M ₂	DKK	Y4	NCG	H5G / -S / -Z	X5G-Z / -S	ESG 4	ESG 5	HDG 2	ZSG 4	ZSG mini	DSG 4	Verso	HSG	
			18							875,00	80 890 35300	●	●	●	●				●	●	●	●	

Positioneringsliste

- ▲ Til trinbakker med T-not
- ▲ Forskellige indspændingsdybder kan opnås ved overfræsning
- ▲ Ved overfræsning af et trin anvendelig som anslagsliste
- ▲ Materiale 1.7131 kan derved efter behov efterfølgende hærdes
- ▲ Pris pr. stk.

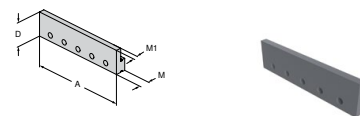

Til skruestikbredde	A	A ₁	D	D ₁	D ₂	E	M	M ₁	M ₂	DKK	Y4	NCG	H5G / -S / -Z	X5G-Z / -S	ESG 4	ESG 5	HDG 2	ZSG 4	ZSG mini	DSG 4	Verso	HSG	
	100		32				13,5	7		366,00	80 892 338	●	●	●	●			●	●	●	●	●	
	125		32				13,5	7		384,00	80 892 339	●	●	●	●			●	●	●	●	●	
	160		32				13,5	7		372,00	80 892 340	●	●	●	●			●	●	●	●	●	

Oversigt almene topbakker

Trinbakke, grip med T-not

- ▲ T-not til fastholdelse af en positioneringsliste
- ▲ Via 6,5 mm bred monteringsflade velegnet til emner med grove overflader
- ▲ Laset stregdeling (2 mm) som positioneringshjælp
- ▲ Pris pr. stk.

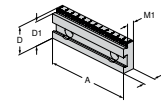

Til skruestikbredde	A	A ₁	D	D ₁	D ₂	E	M	M ₁	M ₂	DKK	Y4	NCG	H5G / -S / -Z	X5G-Z / -S	ESG 4	ESG 5	HDG 2	ZSG 4	ZSG mini	DSG 4	Verso	HSG	
100			35	32			17,5	11,5		980,00	80 892 341	●					●						●
100			35	30			17,5	11,5		980,00	80 892 342	●					●						●
100			35	27			17,5	11,5		980,00	80 892 343	●					●						●
125			40	37			17,5	11,5		1.062,00	80 892 344	●	●		●		●			●			●
125			40	35			17,5	11,5		1.055,00	80 892 345	●	●		●		●			●			●
125			40	32			17,5	11,5		1.055,00	80 892 346	●	●		●		●			●			●
160			50	45			20	13,5		1.182,00	80 892 348	●			●		●			●			●
160			50	42			20	13,5		1.182,00	80 892 349	●			●		●			●			●

Trinbakke, glat

- ▲ Pris pr. stk.

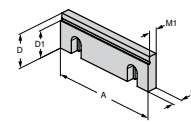

Til skruestikbredde	A	A ₁	D	D ₁	D ₂	E	M	M ₁	M ₂	DKK	Y4	NCG	H5G / -S / -Z	X5G-Z / -S	ESG 4	ESG 5	HDG 2	ZSG 4	ZSG mini	DSG 4	Verso	HSG	
100			35	30			10	7,5		646,00	80 892 21400	●					●						●
125			40	32			11,5	9,5		770,00	80 892 21500	●	●		●		●			●			●
160			50	42			13,5	10,5		1.391,00	80 892 21600	●			●		●			●			●

Trinbakke, glat

- ▲ Kan anvendes som glat bakke eller trinbakke vandret eller lodret
- ▲ Bakke hærdet og slebet
- ▲ Pris pr. stk.

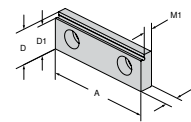

Til skruestikbredde	A	A ₁	D	D ₁	D ₂	E	M	M ₁	M ₂	DKK	Y4	NCG	H5G / -S / -Z	X5G-Z / -S	ESG 4	ESG 5	HDG 2	ZSG 4	ZSG mini	DSG 4	Verso	HSG	
65			22	19			8	5,5		542,00	80 895 332	●											

Trinbakke, belagt 5 mm

- ▲ Pris pr. stk.

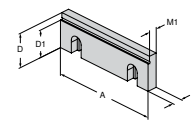

Til skruestikbredde	A	A ₁	D	D ₁	D ₂	E	M	M ₁	M ₂	DKK	Y4	NCG	H5G / -S / -Z	X5G-Z / -S	ESG 4	ESG 5	HDG 2	ZSG 4	ZSG mini	DSG 4	Verso	HSG	
80			28	23			10	7,5		1.167,00	80 878 31400				●			●		●			

Øversigt almene topbakker

Trinbakke, belagt 5 mm

▲ Pris pr. stk.

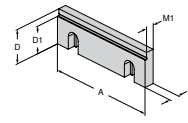

Til skruestikbredde	A	A ₁	D	D ₁	D ₂	E	M	M ₁	M ₂	DKK	Y4	NCG	H5G / -S / -Z	X5G-Z / -S	ESG 4	ESG 5	HDG 2	ZSG 4	ZSG mini	DSG 4	Verso	HSG	
100			35	30			10	7,5		1.279,00	80 892 36300	●					●						
125			40	35			11,5	9,5		1.129,00	80 892 250	●	●		●		●				●		●
160			50	45			13,5	10,5		1.593,00	80 892 36400	●			●		●	●					●

Trinbakke, 5 mm

▲ Pris pr. stk.

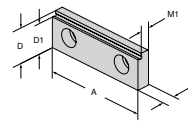

Til skruestikbredde	A	A ₁	D	D ₁	D ₂	E	M	M ₁	M ₂	DKK	Y4	NCG	H5G / -S / -Z	X5G-Z / -S	ESG 4	ESG 5	HDG 2	ZSG 4	ZSG mini	DSG 4	Verso	HSG	
80			28	23			10	7,5		957,00	80 878 830				●				●		●		

Trinbakke, grip

▲ Pris pr. stk.

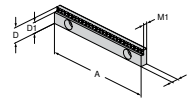

Til skruestikbredde	A	A ₁	D	D ₁	D ₂	E	M	M ₁	M ₂	DKK	Y4	NCG	H5G / -S / -Z	X5G-Z / -S	ESG 4	ESG 5	HDG 2	ZSG 4	ZSG mini	DSG 4	Verso	HSG	
125			18	13			8	5,5		1.010,00	80 898 252		●		●								
125			18	15			8	5,5		1.010,00	80 898 250		●		●						●		

Trinbakke, grip, 3 mm

▲ Pris pr. stk.

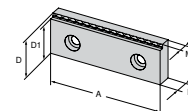

Til skruestikbredde	A	A ₁	D	D ₁	D ₂	E	M	M ₁	M ₂	DKK	Y4	NCG	H5G / -S / -Z	X5G-Z / -S	ESG 4	ESG 5	HDG 2	ZSG 4	ZSG mini	DSG 4	Verso	HSG	
80			28	25			10	7		686,00	80 906 30900				●								

Oversigt almene topbakker

Trinbakke, grip 3, 5 og 8 mm

▲ Pris pr. stk.

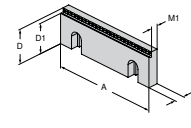

Til skruestikbredde	A	A ₁	D	D ₁	D ₂	E	M	M ₁	M ₂	DKK	Y4	NCG	H5G / -S / -Z	X5G-Z / -S	ESG 4	ESG 5	HDG 2	ZSG 4	ZSG mini	DSG 4	Verso	HSG	
100			35	27			10	7,5		808,00	80 892 29200	●					●					●	
100			35	30			10	7,5		808,00	80 892 29000	●					●						●
100			35	32			10	7,5		808,00	80 892 29400	●					●						●
125			40	32			11,5	9		928,00	80 892 29300	●	●		●		●	●		●			●
125			40	35			11,5	9		928,00	80 892 29100	●	●		●		●	●		●			●
125			40	37			11,5	9		928,00	80 892 29500	●	●		●		●	●		●			●
160			50	42			13,5	11		1.032,00	80 892 29900	●			●		●	●		●			
160			50	45			13,5	11		1.032,00	80 892 29800	●			●		●	●		●			
160			50	47			13,5	11		1.032,00	80 892 29700	●			●		●	●		●			

Trinbakke, hårdmetal, grip 3 mm

▲ Pris pr. stk.

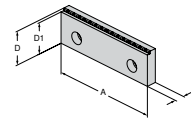

Til skruestikbredde	A	A ₁	D	D ₁	D ₂	E	M	M ₁	M ₂	DKK	Y4	NCG	H5G / -S / -Z	X5G-Z / -S	ESG 4	ESG 5	HDG 2	ZSG 4	ZSG mini	DSG 4	Verso	HSG	
100			35	32			7,5			1.167,00	80 892 37600	●	●		●		●	●		●			
125			40	37			11,5			1.279,00	80 892 36500	●	●		●		●	●		●			
160			50	47			13,5			1.459,00	80 892 37400	●	●		●		●	●		●			

Trinbakke, hårdmetal, grip 5 mm

▲ Pris pr. stk.

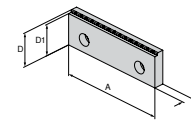

Til skruestikbredde	A	A ₁	D	D ₁	D ₂	E	M	M ₁	M ₂	DKK	Y4	NCG	H5G / -S / -Z	X5G-Z / -S	ESG 4	ESG 5	HDG 2	ZSG 4	ZSG mini	DSG 4	Verso	HSG	
100			35	30			12			1.167,00	80 892 37700	●	●		●		●	●		●			
125			40	35			13,5			1.279,00	80 892 37500	●	●		●		●	●		●			
160			50	45			15,5			1.459,00	80 892 37300	●	●		●		●	●		●			

Trinbakke, 18 mm med 3 mm grip-trin

▲ Pris pr. stk.

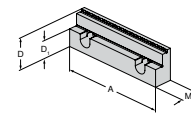

Til skruestikbredde	A	A ₁	D	D ₁	D ₂	E	M	M ₁	M ₂	DKK	Y4	NCG	H5G / -S / -Z	X5G-Z / -S	ESG 4	ESG 5	HDG 2	ZSG 4	ZSG mini	DSG 4	Verso	HSG	
125			40	22			21,5			1.661,00	80 892 288	●	●		●		●	●		●			●

Oversigt almene topbakker

Trinbakke, 18 mm med 3 mm grip-trin

▲ Pris pr. stk.

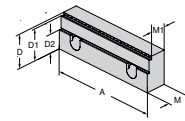

Til skruestikbredde	A	A ₁	D	D ₁	D ₂	E	M	M ₁	M ₂	DKK	Y4	NCG	H5G / -S / -Z	X5G-Z / -S	ESG 4	ESG 5	HDG 2	ZSG 4	ZSG mini	DSG 4	Verso	HSG	
	125		40	37	22		24	19		1.758,00	80 907 302	●	●		●		●	●	●	●		●	●

Trinbakke, grip 5 mm til aluminium og plast

▲ Pris pr. stk.

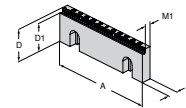

Til skruestikbredde	A	A ₁	D	D ₁	D ₂	E	M	M ₁	M ₂	DKK	Y4	NCG	H5G / -S / -Z	X5G-Z / -S	ESG 4	ESG 5	HDG 2	ZSG 4	ZSG mini	DSG 4	Verso	HSG	
	125		40	35			11,5	8		1.070,00	80 892 36100	●	●		●		●	●	●	●	●	●	●

Trinbakke prægeprofil

▲ Pris pr. stk.

▲ Passer til prægeprofil LANG

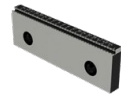
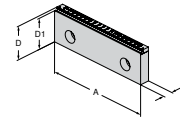

Til skruestikbredde	A	A ₁	D	D ₁	D ₂	E	M	M ₁	M ₂	DKK	Y4	NCG	H5G / -S / -Z	X5G-Z / -S	ESG 4	ESG 5	HDG 2	ZSG 4	ZSG mini	DSG 4	Verso	HSG	
	125		40	37			11,5			1.032,00	80 892 36200	●	●		●		●	●	●	●	●	●	●

Bakke, grip

▲ Pris pr. stk.

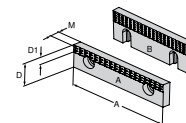
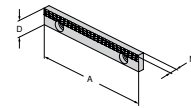

Fig.	A	A ₁	D	D ₁	D ₂	E	M	M ₁	M ₂	DKK	Y4	NCG	H5G / -S / -Z	X5G-Z / -S	ESG 4	ESG 5	HDG 2	ZSG 4	ZSG mini	DSG 4	Verso	HSG	
A	40		22	7			7,8			251,00	80 892 279											●	
A	65		22	7			7,8			283,00	80 892 280											●	
A	90		22	7			7,8			307,00	80 892 284											●	
B	100		35	12			10			388,00	80 892 21700	●					●						●
B	125		40	14,5			11,5			453,00	80 892 21800	●			●		●				●		●
B	160		50	14,5			13,5			622,00	80 892 21900	●			●		●	●					●

Oversigt almene topbakker

Topbakke, grip

▲ Pris pr. stk.



Til skruestikbredde	A	A ₁	D	D ₁	D ₂	E	M	M ₁	M ₂	DKK	Y4	NCG	H5G / -S / -Z	X5G-Z / -S	ESG 4	ESG 5	HDG 2	ZSG 4	ZSG mini	DSG 4	Verso	HSG	
	125		18				7,8			500,00	80 898 253	●	●		●						●		

Topbakke slebet

▲ Pris pr. stk.

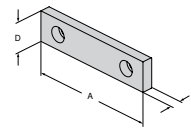

Til skruestikbredde	A	A ₁	D	D ₁	D ₂	E	M	M ₁	M ₂	DKK	Y4	NCG	H5G / -S / -Z	X5G-Z / -S	ESG 4	ESG 5	HDG 2	ZSG 4	ZSG mini	DSG 4	Verso	HSG	
	40		22				7,7			251,00	80 889 401												
	40		35				10			283,00	80 889 405												●
	65		22				7,7			283,00	80 889 651												●
	65		35				10			307,00	80 889 655												●
	90		22				7,7			307,00	80 889 901												●
	90		35				10			372,00	80 889 905												●

Topbakke slebet

▲ Pris pr. stk.

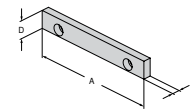

Til skruestikbredde	A	A ₁	D	D ₁	D ₂	E	M	M ₁	M ₂	DKK	Y4	NCG	H5G / -S / -Z	X5G-Z / -S	ESG 4	ESG 5	HDG 2	ZSG 4	ZSG mini	DSG 4	Verso	HSG	
	125		18				7,6			380,00	80 898 251	●	●		●						●		

Topbakke WC belagt

▲ Belagt med wolfram-hårdmetal

▲ Pris pr. stk.

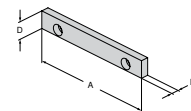

Til skruestikbredde	A	A ₁	D	D ₁	D ₂	E	M	M ₁	M ₂	DKK	Y4	NCG	H5G / -S / -Z	X5G-Z / -S	ESG 4	ESG 5	HDG 2	ZSG 4	ZSG mini	DSG 4	Verso	HSG	
	125		18				7,6			763,00	80 898 254	●	●		●						●		

Oversigt almene topbakker

Bakke, glat

▲ Pris pr. stk.

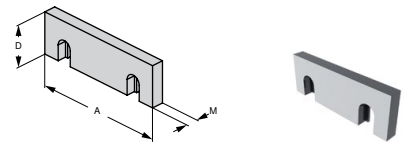

Til skruestikbredde	A	A ₁	D	D ₁	D ₂	E	M	M ₁	M ₂	DKK	Y4	NCG	H5G / -S / -Z	X5G-Z / -S	ESG 4	ESG 5	HDC 2	ZSG 4	ZSG mini	DSG 4	Veriso	HSG	
100			35				10			299,00	80 892 20400	●					●						●
125			40				11,5			364,00	80 892 20500	●			●		●				●		●
160			50				13,5			559,00	80 892 20600	●			●		●	●					●

Bakke, profileret

▲ Pris pr. stk.

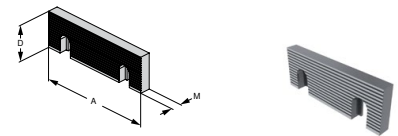

Til skruestikbredde	A	A ₁	D	D ₁	D ₂	E	M	M ₁	M ₂	DKK	Y4	NCG	H5G / -S / -Z	X5G-Z / -S	ESG 4	ESG 5	HDC 2	ZSG 4	ZSG mini	DSG 4	Veriso	HSG	
100			35				10			340,00	80 892 20700	●					●						●
125			40				11,5			412,00	80 892 20800	●			●		●				●		●
160			50				13,5			678,00	80 892 20900	●			●		●	●					●

Grip-bakke, vendbar

▲ Til vertikal og horisontal anvendelse

▲ Pris pr. stk.

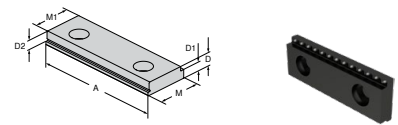

Til skruestikbredde	A	A ₁	D	D ₁	D ₂	E	M	M ₁	M ₂	DKK	Y4	NCG	H5G / -S / -Z	X5G-Z / -S	ESG 4	ESG 5	HDC 2	ZSG 4	ZSG mini	DSG 4	Veriso	HSG	
65			8	5,5	5		22	19		275,00	80 895 340	●	●										
100			10,5	8	5		35	32		388,00	80 895 343	●					●						●

Grip-bakke, vendbar

▲ Til vertikal og horisontal anvendelse

▲ 3-punkt spændinger

▲ Pris pr. stk.

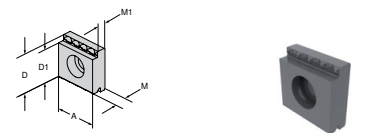

Til skruestikbredde	A	A ₁	D	D ₁	D ₂	E	M	M ₁	M ₂	DKK	Y4	NCG	H5G / -S / -Z	X5G-Z / -S	ESG 4	ESG 5	HDC 2	ZSG 4	ZSG mini	DSG 4	Veriso	HSG	
65	22		22	19			8	5,5		146,00	80 895 335	●	●					●					
100	35		35	32			10,5	8		235,00	80 895 345	●					●						

Oversigt almene topbakker

Bakke, hugget

▲ Pris pr. stk.

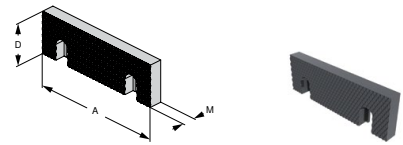

Til skruestikbredde	A	A ₁	D	D ₁	D ₂	E	M	M ₁	M ₂	DKK	Y4	NCG	H5G / -S / -Z	X5G-Z / -S	ESG 4	ESG 5	HDG 2	ZSG 4	ZSG mini	DSG 4	Verso	HSG	
100			35				11			404,00	80 892 20100	●					●						●
125			40				12,5			493,00	80 892 20200	●			●		●				●		●
160			50				14,5			573,00	80 892 20300	●			●		●	●					●

Bakke, hugget

▲ Pris pr. stk.

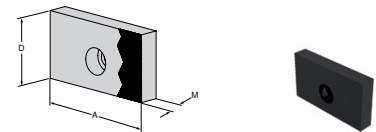

Til skruestikbredde	A	A ₁	D	D ₁	D ₂	E	M	M ₁	M ₂	DKK	Y4	NCG	H5G / -S / -Z	X5G-Z / -S	ESG 4	ESG 5	HDG 2	ZSG 4	ZSG mini	DSG 4	Verso	HSG		
40			35				11			283,00	80 889 408											●		
40			22				8			251,00	80 889 404												●	
65			35				11			307,00	80 889 658												●	
65			22				8			283,00	80 889 654												●	
90			35				11			372,00	80 889 908												●	
90			22				8			307,00	80 889 904												●	

Blød bakke

- ▲ Materiale: 16MnCr5
- ▲ Kun til vertikal anvendelse
- ▲ Pris pr. stk.

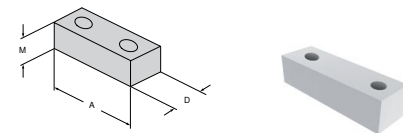

Til skruestikbredde	A	A ₁	D	D ₁	D ₂	E	M	M ₁	M ₂	DKK	Y4	NCG	H5G / -S / -Z	X5G-Z / -S	ESG 4	ESG 5	HDG 2	ZSG 4	ZSG mini	DSG 4	Verso	HSG		
40			22				20			251,00	80 895 244											●		
65			22				20			283,00	80 895 245		●		●			●					●	
90			22				20			307,00	80 895 246												●	

Blød bakke

- ▲ Materiale: 14NiCr14
- ▲ Til fremstilling af forbakker
- ▲ Pris pr. stk.

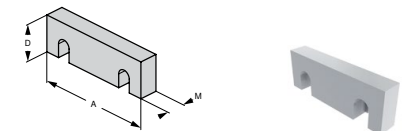

Til skruestikbredde	A	A ₁	D	D ₁	D ₂	E	M	M ₁	M ₂	DKK	Y4	NCG	H5G / -S / -Z	X5G-Z / -S	ESG 4	ESG 5	HDG 2	ZSG 4	ZSG mini	DSG 4	Verso	HSG	
100			35				16			323,00	80 892 24700	●					●						●
125			40				20			380,00	80 892 24800	●	●		●		●	●		●			●
160			50				20			624,00	80 892 24900	●			●		●	●					●

Oversigt almene topbakker

Topbakke

- ▲ Pris pr. stk.
- ▲ Med horisontal og vertikal prisme
- ▲ Prisme-parallellitet horisontal og vertikal slebet

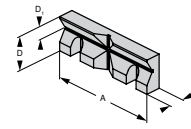

til spænddiameter	A	A ₁	D	D ₁	D ₂	E	M	M ₁	M ₂	DKK	Y4	NCG	H5G / -S / -Z	X5G-Z / -S	ESG 4	ESG 5	HDG 2	ZSG 4	ZSG mini	DSG 4	Verso	HSG	
11 - 41	100		35	13			15,5			960,00	80 892 26100	●						●					●
14 - 48	125		40	16			17,5			1.069,00	80 892 26200	●	●		●		●				●		●
16 - 60	160		50	20			19,5			1.601,00	80 892 26300	●			●		●	●					●

Topbakke

- ▲ Med horisontal og vertikal prisme
- ▲ Pris pr. stk.

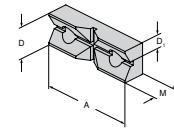

til spænddiameter	A	A ₁	D	D ₁	D ₂	E	M	M ₁	M ₂	DKK	Y4	NCG	H5G / -S / -Z	X5G-Z / -S	ESG 4	ESG 5	HDG 2	ZSG 4	ZSG mini	DSG 4	Verso	HSG	
11 - 22	65		22	11			15			980,00	80 895 337	●						●					

Præcisions-nedtræksbakke

- ▲ Nedtræksbakke er kun beregnet til brug på den bevægelige bakke
- ▲ Pris pr. stk.

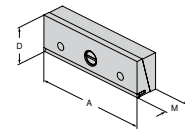

Til skruestikbredde	A	A ₁	D	D ₁	D ₂	E	M	M ₁	M ₂	DKK	Y4	NCG	H5G / -S / -Z	X5G-Z / -S	ESG 4	ESG 5	HDG 2	ZSG 4	ZSG mini	DSG 4	Verso	HSG	
100			35				25			1.937,00	80 892 370	●											●
125			40				25			2.005,00	80 892 371	●	●		●		●				●		●
160			50				27,5			3.059,00	80 892 372	●			●		●	●					●

Mellembakke med nedtræk

- ▲ Til typerne NCG, NCG 2 og HDG 2
- ▲ Med nedtræks-fjederblade i begge sider
- ▲ Pris pr. stk.

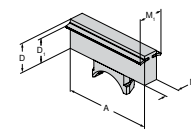

Til skruestikbredde	A	A ₁	D	D ₁	D ₂	E	M	M ₁	M ₂	DKK	Y4	NCG	H5G / -S / -Z	X5G-Z / -S	ESG 4	ESG 5	HDG 2	ZSG 4	ZSG mini	DSG 4	Verso	HSG	
100			35	28			28	45		2.162,00	80 892 258	●											
125			40	32,5			20	35		2.117,00	80 892 259	●					●						
160			50	42			20	35		2.521,00	80 892 260	●					●						

Oversigt almene topbakker

Multipin forsatsbakke

▲ Pris pr. stk.

NCG HDG
2



80 890 ...

DKK
Y4
2.356,00 30200

A mm	D mm
125	40

Fjederplade nedtræksbakke

▲ Pris pr. stk.

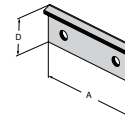

Til skruestikbredde	A	A ₁	D	D ₁	D ₂	E	M	M ₁	M ₂	DKK	Y4	NCG	H5G / -S / -Z	X5G-Z / -S	ESG 4	ESG 5	HDG 2	ZSG 4	ZSG mini	DSG 4	Verso	HSG	
	80		24							500,00	80 901 309												
	125		35							654,00	80 901 310												
	160		45							743,00	80 901 311												

Fjederplade nedtræksbakke

▲ Pris pr. stk.

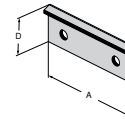

Til skruestikbredde	A	A ₁	D	D ₁	D ₂	E	M	M ₁	M ₂	DKK	Y4	NCG	H5G / -S / -Z	X5G-Z / -S	ESG 4	ESG 5	HDG 2	ZSG 4	ZSG mini	DSG 4	Verso	HSG	
	65		23							429,00	80 898 923												
	100		36							549,00	80 898 924												
	125		41							654,00	80 898 925												
	160		51							743,00	80 898 926												

Fjederplade nedtræksbakke

▲ Pris pr. stk.

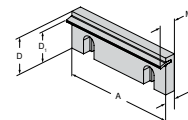

Til skruestikbredde	A	A ₁	D	D ₁	D ₂	E	M	M ₁	M ₂	DKK	Y4	NCG	H5G / -S / -Z	X5G-Z / -S	ESG 4	ESG 5	HDG 2	ZSG 4	ZSG mini	DSG 4	Verso	HSG	
	100		35	28			10	18,5		445,00	80 892 22800												
	125		40	32,5			11,5	19		517,00	80 892 22900												
	160		50	42			13,5	21		670,00	80 892 23000												

Oversigt emnestøtter

Emnestøtte, forskudt

- ▲ Hærdet og slebet
- ▲ Fastholdes i grundpladen af låsefjedre
- ▲ Pris pr. 2 stk.

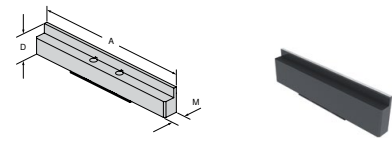

Til skruestikbredde	A	A ₁	D	D ₁	D ₂	E	M	M ₁	M ₂	DKK	Y4	NCG	H5G / -S / -Z	X5G-Z / -S	ESG 4	ESG 5	HDG 2	ZSG 4	ZSG mini	DSG 4	Verso	HSG		
100			16				10,5			1.010,00	80 890 401	●												
100			11				10,5			1.010,00	80 890 400	●												
100			23				10,5			1.010,00	80 890 409	●												
100			25,5				10,5			1.010,00	80 890 411	●												
100			29,5				10,5			1.010,00	80 890 421	●												
125			32,5				10,5			1.174,00	80 890 395	●												
125			11				10,5			1.174,00	80 890 390	●												
125			16				10,5			1.174,00	80 890 391	●												
125			21				10,5			1.174,00	80 890 392	●												
125			26				10,5			1.174,00	80 890 393	●												
125			29				10,5			1.174,00	80 890 394	●												
125			36				10,5			1.174,00	80 890 396	●												
125			25				10,5			1.174,00	80 890 422	●												
160			39				10,5			1.496,00	80 890 454	●												
160			26				10,5			1.421,00	80 890 452	●												
160			42,5				10,5			1.601,00	80 890 456	●												

Til skruestikbredde	A	A ₁	D	D ₁	D ₂	E	M	M ₁	M ₂	DKK	Y4	NCG	H5G / -S / -Z	X5G-Z / -S	ESG 4	ESG 5	HDG 2	ZSG 4	ZSG mini	DSG 4	Verso	HSG	
125							10,5			7.704,00	80 890 399	●											

 **80 890 399:** Sæt med 7 emneholdere à 2 stk. i trækasse (ekskl. **80 890 422**)

Emnestøtte, forskudt

- ▲ Hærdet og slebet
- ▲ Fastholdes i grundplade af låsefjedre
- ▲ Levering i sæt a 2 stk.
- ▲ Pris pr. sæt

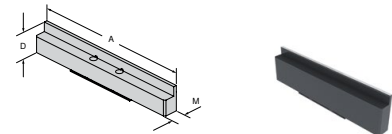

Til skruestikbredde	A	A ₁	D	D ₁	D ₂	E	M	M ₁	M ₂	DKK	Y4	NCG	H5G / -S / -Z	X5G-Z / -S	ESG 4	ESG 5	HDG 2	ZSG 4	ZSG mini	DSG 4	Verso	HSG			
125			11				10,5			1.144,00	80 901 703				●										
125			21				10,5			1.174,00	80 901 704				●										
125			25				10,5			1.144,00	80 901 705				●										
160			26				10,5			1.391,00	80 901 700				●										
125			32,5				10,5			1.144,00	80 901 706				●										
160			39				10,5			1.466,00	80 901 701				●										
160			42,5				10,5			1.571,00	80 901 702				●										

Emnestøtte, forskudt

- ▲ Hærdet og slebet
- ▲ Fastholdes i grundplade af låsefjedre
- ▲ Levering i sæt a 2 stk.
- ▲ Pris pr. sæt

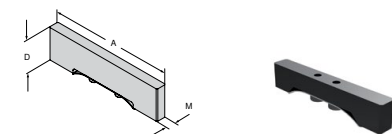

Til skruestikbredde	A	A ₁	D	D ₁	D ₂	E	M	M ₁	M ₂	DKK	Y4	NCG	H5G / -S / -Z	X5G-Z / -S	ESG 4	ESG 5	HDG 2	ZSG 4	ZSG mini	DSG 4	Verso	HSG				
80			15				10,5			950,00	80 901 707				●											
80			20				10,5			950,00	80 901 708				●											

Oversigt emnestøtter

Emnestøtte, forskudt

- ▲ Hærdet og slebet
- ▲ Fastholdes i skruestik af låsefjedre
- ▲ Levering i sæt a 2 stk.
- ▲ Pris pr. sæt

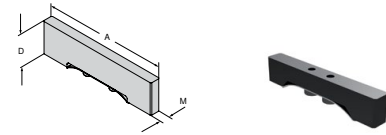

Til skruestikbredde	A	A ₁	D	D ₁	D ₂	E	M	M ₁	M ₂	DKK	Y4	NCG	H5G / -S / -Z	X5G-Z / -S	ESG 4	ESG 5	HDG 2	ZSG 4	ZSG mini	DSG 4	Verso	HSG			
125			15				10,5			1.174,00	80 906 715														
125			22				10,5			1.174,00	80 906 722														●
125			25				10,5			1.174,00	80 906 725														●
125			32,5				10,5			1.174,00	80 906 732														●

Emnestøtte, forskudt

- ▲ Hærdet og slebet
- ▲ Fastholdes i skruestik af låsefjedre
- ▲ Pris pr. 2 stk.

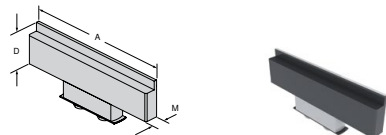

Til skruestikbredde	A	A ₁	D	D ₁	D ₂	E	M	M ₁	M ₂	DKK	Y4	NCG	H5G / -S / -Z	X5G-Z / -S	ESG 4	ESG 5	HDG 2	ZSG 4	ZSG mini	DSG 4	Verso	HSG				
100			16				10,5			980,00	80 892 401															
100			25,5				10,5			980,00	80 892 411															●
100			29,5				10,5			980,00	80 892 421															●
125			11				10,5			1.174,00	80 892 390															●
125			16				10,5			1.174,00	80 892 391															●
125			21				10,5			1.174,00	80 892 392															●
125			26				10,5			1.174,00	80 892 393															●
125			29				10,5			1.174,00	80 892 394															●
125			32,5				10,5			1.174,00	80 892 395															●
125			36				10,5			1.174,00	80 892 396															●
160			26				10,5			1.421,00	80 892 403															●
160			39				10,5			1.496,00	80 892 413															●
160			42,5				10,5			1.601,00	80 892 423															●

Til skruestikbredde	A	A ₁	D	D ₁	D ₂	E	M	M ₁	M ₂	DKK	Y4	NCG	H5G / -S / -Z	X5G-Z / -S	ESG 4	ESG 5	HDG 2	ZSG 4	ZSG mini	DSG 4	Verso	HSG			
125							10,5			7.704,00	80 892 399							●							

80 892 399: Sæt med 7 emneholdere à 2 stk. i trækasse

Magnet-emnestøtte, sæt



- ▲ Med frigang på undersiden
- ▲ Fleksibel og rationel opspænding
- ▲ Højdenøjagtighed +/- 0,01 mm
- ▲ Monteres nemt og hurtigt med magnethæftning

Oversigt emnestøtter

Magnet-emnestøtte, sæt

- ▲ Rustfrit fjederstål
- ▲ Indpressede magneter
- ▲ Levering i sæt: 5 par a 2 stk.
- ▲ Pris pr. sæt



A	D	M	DKK	Y4	NCG	H5G / -S / -Z	X5G-Z / -S	ESG 4	ESG 5	HDG 2	ZSG 4	ZSG mini	DSG 4	Veris	HSG
80	5 / 10 / 15 / 20 / 22	2,5	2.222,00	80 878 79800	●		●	●			●		●		
125	8 / 12 / 15 / 20 / 22	2,5	2.498,00	80 878 79700	●		●	●			●		●		
125	8 / 12 / 20 / 25 / 27	2,5	2.498,00	80 878 79900	●		●	●			●		●		

Magnet-emnestøtte, sæt

- ▲ Rustfrit fjederstål
- ▲ Indpressede magneter
- ▲ Levering i sæt: 5 par a 2 stk.
- ▲ Pris pr. sæt



A	D	M	DKK	Y4	NCG	H5G / -S / -Z	X5G-Z / -S	ESG 4	ESG 5	HDG 2	ZSG 4	ZSG mini	DSG 4	Veris	HSG
100	12 / 20 / 25 / 30 / 32	2,5	2.431,00	80 892 79700	●		●				●				
125	12 / 25 / 30 / 35 / 37	2,5	2.558,00	80 892 79800	●		●				●		●		
160	15 / 30 / 40 / 45 / 47	2,5	2.693,00	80 892 79900	●		●	●			●		●		

Magnet-emnestøtte, sæt

- ▲ Rustfrit fjederstål
- ▲ Indpressede magneter
- ▲ Levering i sæt: 5 par a 2 stk.
- ▲ Pris pr. sæt



A	D	M	DKK	Y4	NCG	H5G / -S / -Z	X5G-Z / -S	ESG 4	ESG 5	HDG 2	ZSG 4	ZSG mini	DSG 4	Veris	HSG
125	9 / 22 / 27 / 32 / 34	2,5	2.498,00	80 901 79900	●		●				●		●		

Øversigt emnestøtter

Magnet-emnestøtte

▲ Pris pr. par

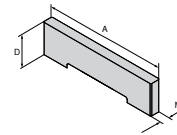

A	D	M	DKK	Y4	NCG	H6G / -S / -Z	X5G-Z / -S	ESG 4	ESG 5	HDG 2	ZSG 4	ZSG mini	DSG 4	Verfo	HSG
80	5	2,5	509,00	80 892 79600											
80	10	2,5	509,00	80 892 79500											
80	15	2,5	509,00	80 892 79400											
80	20	2,5	509,00	80 892 79300											
80	22	2,5	509,00	80 892 79200											
100	12	2,5	533,00	80 892 79100											
100	20	2,5	533,00	80 892 79000											
100	25	2,5	533,00	80 892 78900											
100	27	2,5	533,00	80 892 78800											
100	29	2,5	533,00	80 892 78700											
100	30	2,5	533,00	80 892 78600											
100	31	2,5	533,00	80 892 78500											
100	32	2,5	533,00	80 892 78400											
125	8	2,5	557,00	80 892 78300											
125	9	2,5	557,00	80 892 78200											
125	10	2,5	557,00	80 892 78100											
125	12	2,5	557,00	80 892 78000											
125	15	2,5	557,00	80 892 77900											
125	20	2,5	557,00	80 892 77800											
125	22	2,5	557,00	80 892 77700											
125	23	2,5	557,00	80 892 77600											
125	25	2,5	557,00	80 892 77500											
125	27	2,5	557,00	80 892 77400											
125	30	2,5	557,00	80 892 77300											
125	31	2,5	557,00	80 892 77200											
125	32	2,5	557,00	80 892 77100											
125	33	2,5	557,00	80 892 77000											
125	34	2,5	557,00	80 892 76900											
125	35	2,5	557,00	80 892 76800											
125	36	2,5	557,00	80 892 76700											
125	37	2,5	557,00	80 892 76600											
160	15	2,5	606,00	80 892 76500											
160	22	2,5	606,00	80 892 76400											
160	30	2,5	606,00	80 892 76300											
160	37	2,5	606,00	80 892 76200											
160	40	2,5	606,00	80 892 76100											
160	41	2,5	606,00	80 892 76000											
160	42	2,5	606,00	80 892 75900											
160	43	2,5	606,00	80 892 75800											
160	44	2,5	606,00	80 892 75700											
160	45	2,5	613,00	80 892 75600											
160	46	2,5	606,00	80 892 75500											
160	47	2,5	606,00	80 892 75400											

Emnestop, magnetisk

Leveringsomfang:

Inklusive anslagsstav 50 mm / 100 mm



Til bredde mm	Størrelse
80/100/125/160	60x15
80/100/125/160	115x15

80 892 ...
DKK
Y4
845,00 23800
1.227,00 23900

Forlænger til emnestop, magnetisk

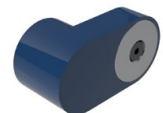

Til bredde mm	Størrelse
80/100/125/160	68x30 mm

80 892 ...
DKK
Y4
654,00 25400

Oversigt generelt tilbehør

Justerings- og centrersæt til T-noter

▲ Pris pr. stk.



80 897 ...

I mm	Til notbredde mm	DKK Y4	
100	14	427,00	114
100	16	427,00	116
100	18	427,00	118

Justerings- og centrersæt til T-noter

▲ Pris pr. stk.

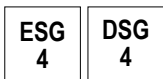

80 906 ...

I mm	Til notbredde mm	DKK Y4	
80	12	445,00	812
80	14	445,00	814
80	16	445,00	816
80	18	445,00	818

Opspændingsboltsæt til T-noter til MNG

▲ Pris pr. 2 stk.



80 899 ...

Til bredde mm	G	DKK Y4	
12	M10	114,00	312
14	M12	114,00	314
16	M12	153,00	316
18	M12	194,00	318

Emnestop



80 892 ...

DKK Y4
611,00 400

Emnestop

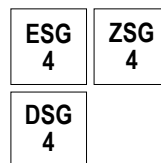

80 895 ...

DKK Y4
335,00 010

Emnestop

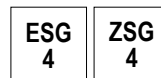

80 884 ...

DKK Y4
327,00 400

Oversigt generelt tilbehør

Ekstra fjederblad

- ▲ Pris pr. stk.
- ▲ Til nedtræksbakker og mellembakker

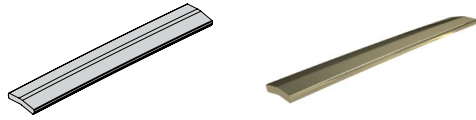

Til bredde mm	80 892 ...	
	DKK	Y4
100	179,00	430
125	186,00	431
160	203,00	432

Spændejern

- ▲ Pris pr. 2 stk.

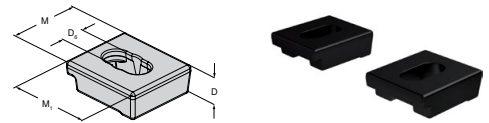

D mm	D ₆ mm	M mm	M ₁ mm	80 890 ...	
				DKK	Y4
20	16	50	57	285,00	315

Oversigt spændearm

Spændearm med led

▲ Uden top

Drejemoment i Nm	Firkant	DRVS	DKK	Y4	NCG	H5G / -S / -Z	X5G-Z / -S	ESG 4	ESG 5	HDC 2	ZSG 4	ZSG mini	DSG 4	Verso	HSG	MNG	MNG mini
	1/2"		569,00	80 891 600				●			●						



Momentnøgle

▲ Uden top

Drejemoment i Nm	Firkant	DRVS	DKK	Y4	NCG	H5G / -S / -Z	X5G-Z / -S	ESG 4	ESG 5	HDC 2	ZSG 4	ZSG mini	DSG 4	Verso	HSG	MNG	MNG mini
10 - 100	1/2"		2.094,00	80 884 502				●									
20 - 200	1/2"		2.094,00	80 884 504				●									



Momentnøgle

▲ Uden top

Drejemoment i Nm	Firkant	DRVS	DKK	Y4	NCG	H5G / -S / -Z	X5G-Z / -S	ESG 4	ESG 5	HDC 2	ZSG 4	ZSG mini	DSG 4	Verso	HSG	MNG	MNG mini
5 - 50	3/8"		2.094,00	80 884 402								●		●		●	



Kontrolsæt

▲ Momentnøgle inkl. møtrik, skruetrækker SW10 og 1/2" forlænger

Drejemoment i Nm	Firkant	DRVS	DKK	Y4	NCG	H5G / -S / -Z	X5G-Z / -S	ESG 4	ESG 5	HDC 2	ZSG 4	ZSG mini	DSG 4	Verso	HSG	MNG	MNG mini
8 - 50	3/8"	10	2.461,00	80 899 410												●	



Oversigt skruer

Spændeskruer til topbakker

▲ DIN EN ISO 4762(1998-02)



Til skruestikbredde	G	J ₁₇	DKK	Y4	NCG	H5G / -S / -Z	X5G-Z / -S	ESG 4	ESG 5	HDG 2	ZSG 4	ZSG mini	DSG 4	Verso	HSG	MNG	MNG mini
M8x12			9,00	80 892 296	●	●					●	●					
M6x8			9,00	80 895 013									●	●			

Spændeskruer med lavt hoved til topbakker

▲ jf. DIN7984 (1985-05)



Til skruestikbredde	G	J ₁₇	DKK	Y4	NCG	H5G / -S / -Z	X5G-Z / -S	ESG 4	ESG 5	HDG 2	ZSG 4	ZSG mini	DSG 4	Verso	HSG	MNG	MNG mini
M8x10			9,00	80 889 950	●	●					●	●					

Opspændingsbolt til systembakker

▲ Pris pr. stk.



Til skruestikbredde	G	J ₁₇	DKK	Y4	NCG	H5G / -S / -Z	X5G-Z / -S	ESG 4	ESG 5	HDG 2	ZSG 4	ZSG mini	DSG 4	Verso	HSG	MNG	MNG mini
M12x20			9,00	80 890 630	●	●											
M12x40			17,00	80 890 632	●	●											

Unbrako bolt

▲ DIN 912



Til skruestikbredde	G	J ₁₇	DKK	Y4	NCG	H5G / -S / -Z	X5G-Z / -S	ESG 4	ESG 5	HDG 2	ZSG 4	ZSG mini	DSG 4	Verso	HSG	MNG	MNG mini
M12x45			17,00	80 899 124												●	

Passkrue

▲ Pris pr. 2 stk.



Til skruestikbredde	G	J ₁₇	DKK	Y4	NCG	H5G / -S / -Z	X5G-Z / -S	ESG 4	ESG 5	HDG 2	ZSG 4	ZSG mini	DSG 4	Verso	HSG	MNG	MNG mini
100	M12x38	12	342,00	80 890 313	●			●									
125 / 160	M16x55	16	455,00	80 890 314	●												

Oversigt skruer

Passkrue

▲ Pris pr. 2 stk.



Til skruestikbredde	G	J ₁₇	DKK	Y4	NCG	H5G / -S / -Z	X5G-Z / -S	ESG 4	ESG 5	HDG 2	ZSG 4	ZSG mini	DSG 4	Verso	HSG	MING	MING mini
125	M12x45	12	196,00	80 895 019	●	●	●	●	●	●	●	●	●			●	

Opspændingsbolt med T-not møtrik

▲ Til fastgørelse af spændejern

▲ Pris pr. 2 stk.



Til notbredde	G	J ₁₇	DKK	Y4	NCG	H5G / -S / -Z	X5G-Z / -S	ESG 4	ESG 5	HDG 2	ZSG 4	ZSG mini	DSG 4	Verso	HSG	MING	MING mini
12	M10		182,00	80 890 308	●	●		●		●	●		●	●			
14	M12		182,00	80 890 309	●	●		●		●	●		●	●			
16	M14		189,00	80 890 310	●	●		●		●	●		●	●			
18	M16		197,00	80 890 311	●	●		●		●	●		●	●			

Opspændingsbolt til runde spændejern, T-not

▲ Inkl. not møtrik og spændeskive

▲ Pris pr. 2 stk.



Til notbredde	G	J ₁₇	DKK	Y4	NCG	H5G / -S / -Z	X5G-Z / -S	ESG 4	ESG 5	HDG 2	ZSG 4	ZSG mini	DSG 4	Verso	HSG	MING	MING mini
12	M10		118,00	80 899 112										●		●	
14	M12		118,00	80 899 114										●		●	
16	M12		129,00	80 899 116										●		●	
18	M12		138,00	80 899 118										●		●	

T-not møtrik inkl. skrue

▲ Pris pr. 2 stk.



Til notbredde	G	J ₁₇	DKK	Y4	NCG	H5G / -S / -Z	X5G-Z / -S	ESG 4	ESG 5	HDG 2	ZSG 4	ZSG mini	DSG 4	Verso	HSG	MING	MING mini
12	M6		682,00	80 898 412	●	●		●		●			●				
14	M6		682,00	80 898 414	●	●		●		●			●				
16	M6		682,00	80 898 416	●	●		●		●			●				
18	M6		682,00	80 898 418	●	●		●		●			●				