

New products for machining technicians

NEW

MaxiMill Slot-SX



→ Page 126-141

New side and face milling system with SX inserts from SX grooving system

NEW

MaxiMill 242



→ Page 90

Update to chamfer milling cutter

NEW

MaxiMill 490



→ Page 78+80

Update to adjustable single angle milling cutter

NEW

CTPX715



New multi-range grade

NEW

MaxiMill 273-08



→ Page 35+36

NEW

MaxiMill 252



→ Page 115+116



Solid drilling and bore machining

- 1 HSS drilling
- 2 Solid carbide drilling
- 3 Indexable insert drilling
- 4 Reaming and Countersinking
- 5 Spindle Tooling

Threading

- 6 Taps and thread formers
- 7 Circular and Thread Milling
- 8 Thread turning

Turning

- 9 Turning Tools
- 10 Multifunctional Tools – EcoCut and FreeTurn
- 11 Grooving Tools
- 12 Miniature turning tools

Milling

- 13 HSS Milling Cutters
- 14 Solid Carbide milling cutters
- 15 Milling tools with indexable inserts

Clamping technology

- 16 Adaptors and Accessories
- 17 Workpiece clamping

- 18 Material examples and article no. Index

Table of contents

Symbol explanation	4
Toolfinder	5–12
Product programme	13–144
Technical Information	
Cutting data standard values	145–148
Application parameters – Face milling	149–158
Application parameters – End milling	159–175
Application parameters – Form milling	176–190
Application parameters – Other milling systems	191+192
Power Screw	193
Abbreviations & dimensions	194
Engagement conditions	195
ISO Designation System	196+197
Cutting Edge Wear Conditions	198
Chip Breakers Overview	199
Chip breaker description	200+201
Grades Overview	202+203
Grade description	204–209

CERATIZIT \ Performance

Premium quality tools for high performance.

The premium quality tools from the **CERATIZIT Performance** product line have been designed for specific applications and are distinguished by their outstanding performance. If you make high demands on the performance of your production and want to achieve the very best results, we recommend the Premium tools in this product line.

Symbol explanation

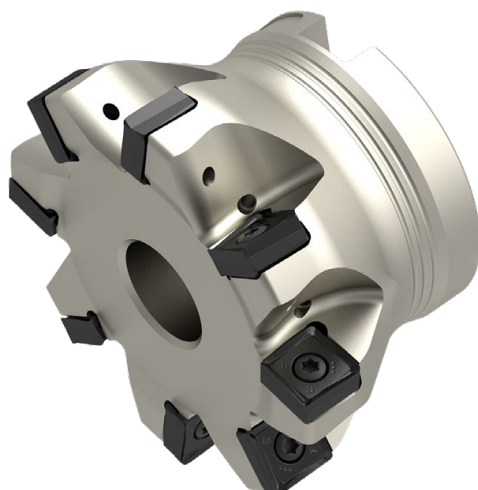
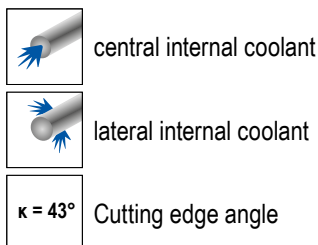

- ZNF = Number of flutes
- = Main Application
- = Extended application

Application symbols

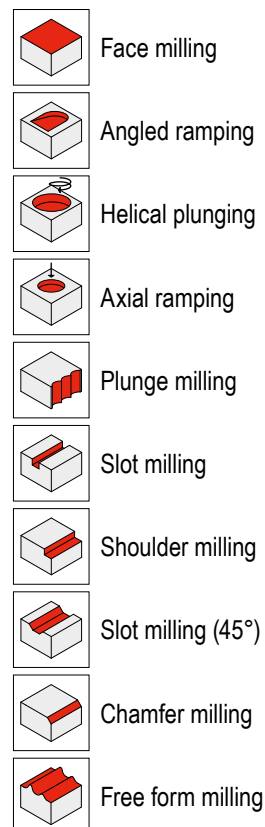



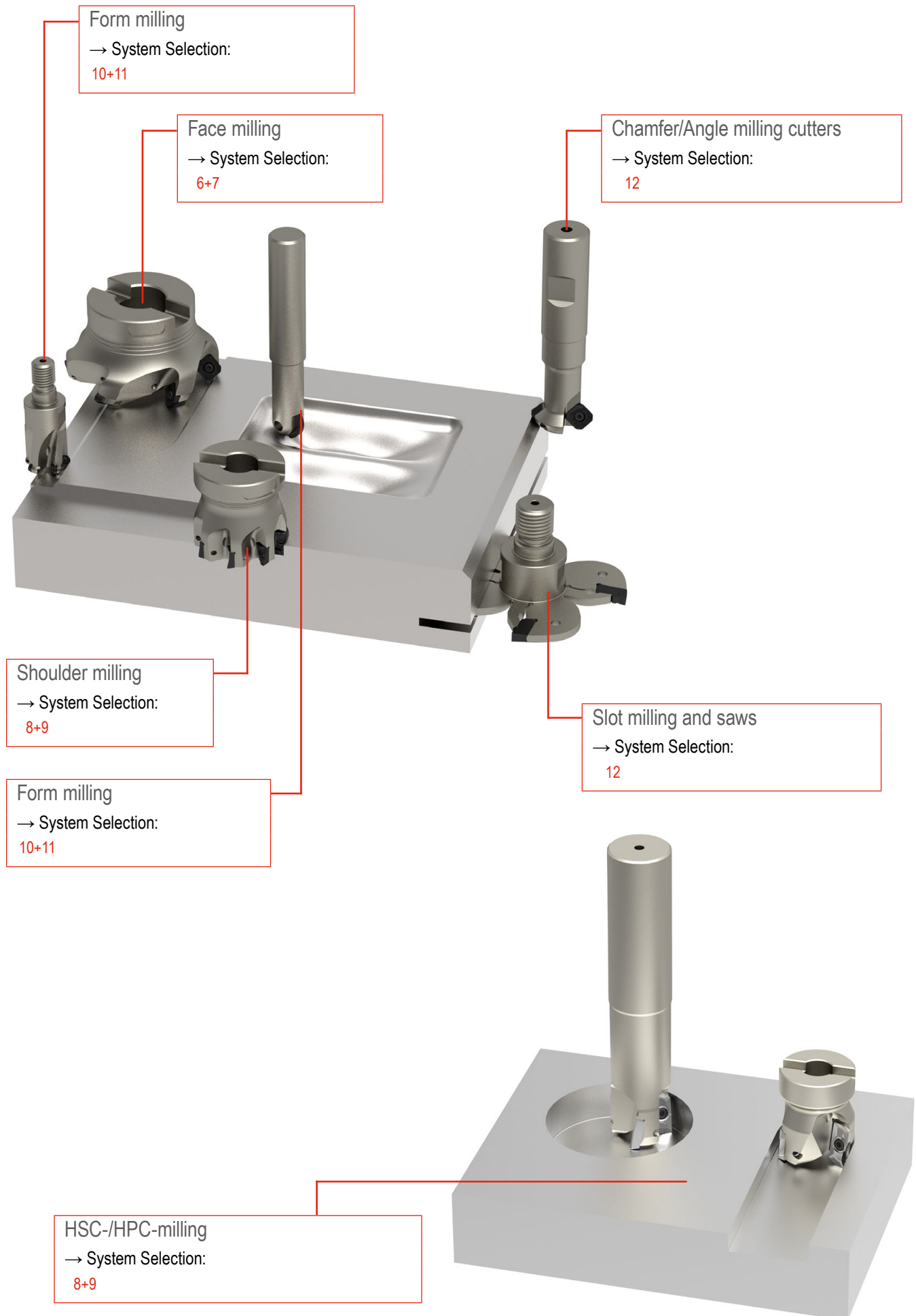



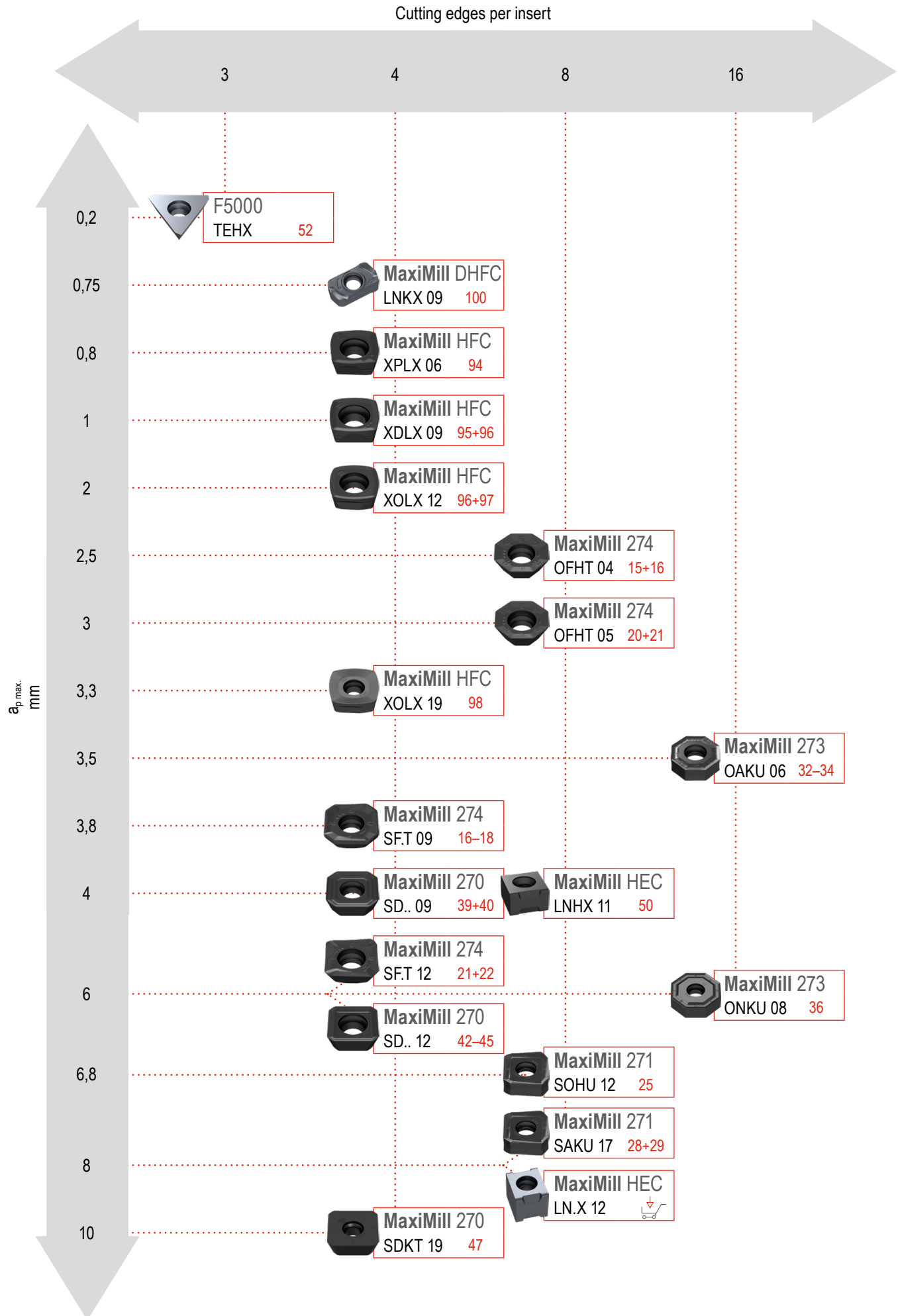









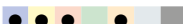

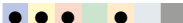



Toolfinder – Application Selection Guide

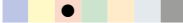

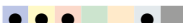

Toolfinder – Face Milling Cutters

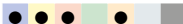

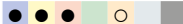
Overview – Face Milling Cutters

System	Inserts	Cutting edges per insert	$a_{p\max}$ mm	\emptyset -range mm		Page No.
MaxiMill 274	OFH. 04.. / 05.. SFT. 09.. / 12..	8 4	2,5–6	  		13–22
MaxiMill 271	SOHU 1204.. SAKU 1706..	8	6,8 8,4	 		23–29
MaxiMill 273	OAKU 0605.. ONKU 0806..	16	3,5 6			30–36
MaxiMill 270	SD.. 0903.. / 1204.. / 19..	4	4–10	 		37–47
MaxiMill HEC	LNHX 1106..	8	4–8			48–50
MaxiMill HEC	LN.X 1210..	8	4–8		 	
F 5000	TEHX 16T3..	3	0,2			51+52
MaxiMill HFC	X..X 06.. / 09.. / 12.. / 19..	4	0,8–3,3	  		92–98
MaxiMill DHFC	LNKX 09..	4	0,75	 		99+100







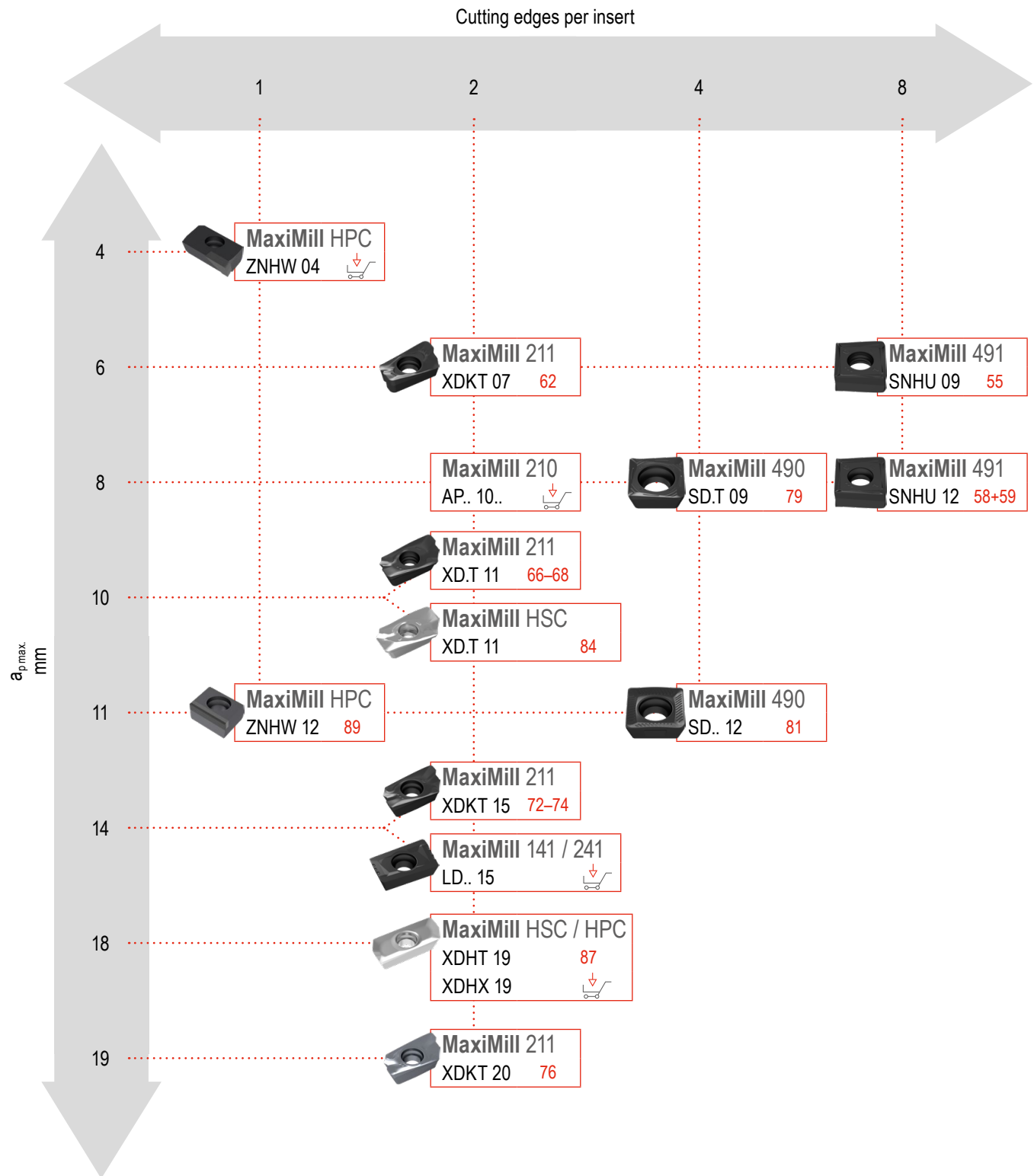





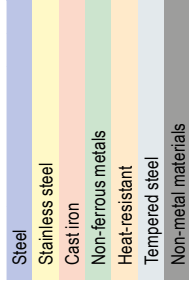





















 Additional diameters are available upon request.

 Indexable inserts for systems that are no longer listed here can be found in our online shop at cuttingtools.ceratizit.com

Toolfinder – shoulder milling



Overview – Shoulder Milling Cutters

System	Inserts	Cutting edges per insert	$a_{p,max}$ mm	Ø-range mm			Material Compatibility	Page No.
MaxiMill 491	SNHU 09T3.. / 1204..	8	6–8	 Ø 25–32	 Ø 25–32	 Ø 40–160		53–59
MaxiMill 211	XD.T 0703.. / 11T3.. / 1505.. / 2007..	2	6–19	 Ø 16–40	 Ø 10–40	 Ø 32–160		60–76
MaxiMill 211KN	XD.T 11T3.. / 1505.. / 2007..	2	27–75,5	 Ø 25–50	 Ø 40–80			65+71
MaxiMill 490	SD.. 09T3.. / 1205..	4	8–11	 Ø 25–32	 Ø 25–32	 Ø 40–125		77
MaxiMill 490K	SD.. 09T3..	4	41			 Ø 40–63		78
MaxiMill HSC	XD.. 11T3.. / 1904..	2	10–18	 Ø 16–40	 Ø 16–32	 Ø 40–125		82–87
MaxiMill HPC	XD.. 1904..	2	10–18	 Ø 22–32	 Ø 40–63	 Ø 25–50	 	
MaxiMill HPC	ZNHW 1205..	1	4–11			 Ø 40–315		88+89
MaxiMill HPC	ZNHW 04T3..	1	4–11	 Ø 20–40	 Ø 20–40		 	
MaxiMill 210	AP.. 1003..	2	8			 Ø 40–80	 	

 Additional diameters are available upon request.

 Indexable inserts for systems that are no longer listed here can be found in our online shop at cuttingtools.ceratizit.com





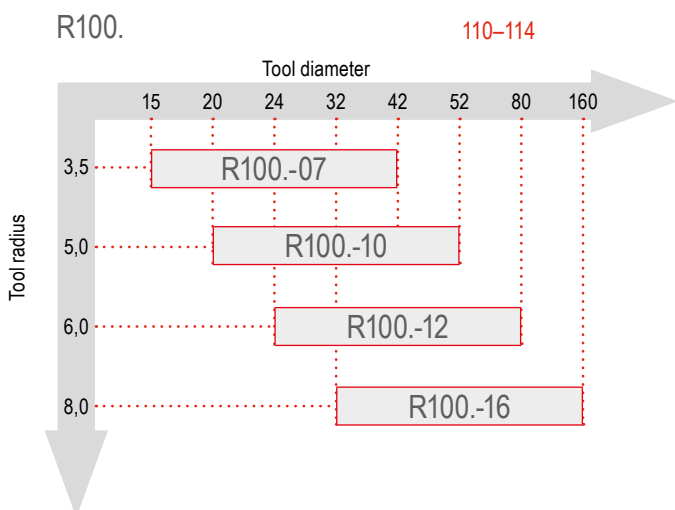
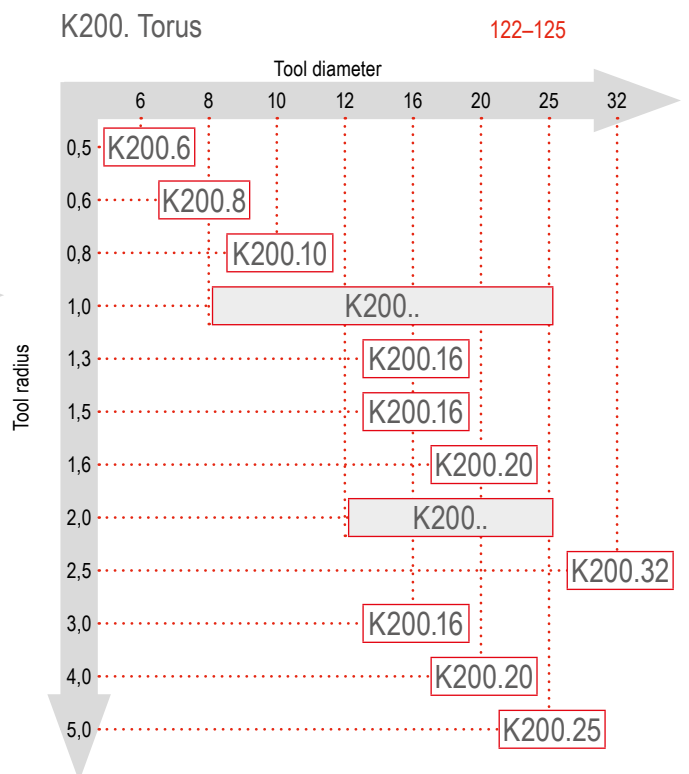
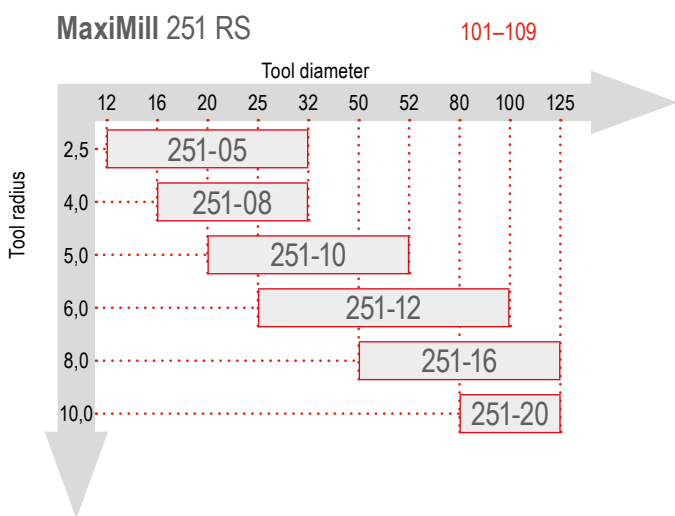
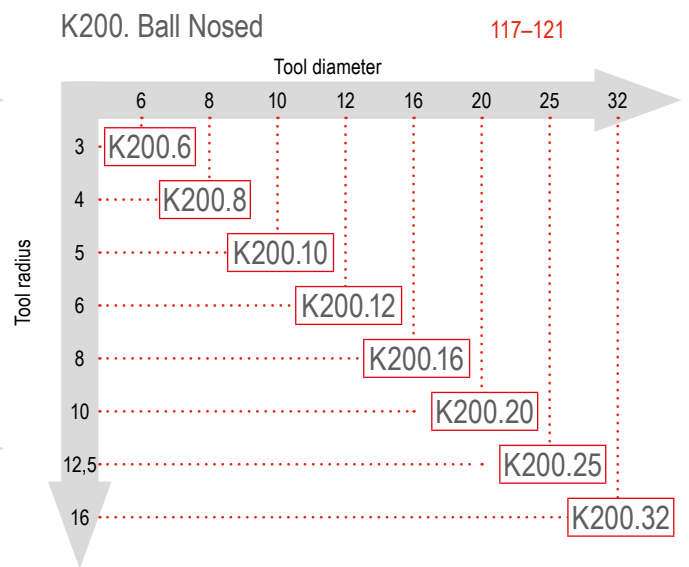
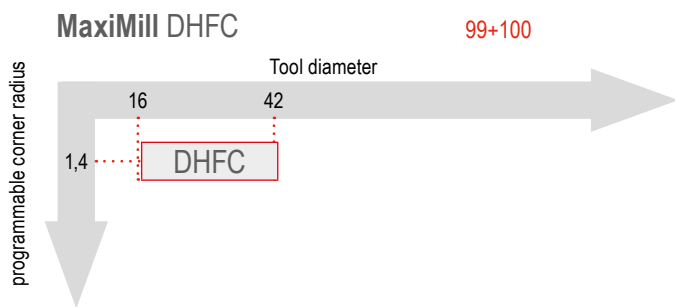
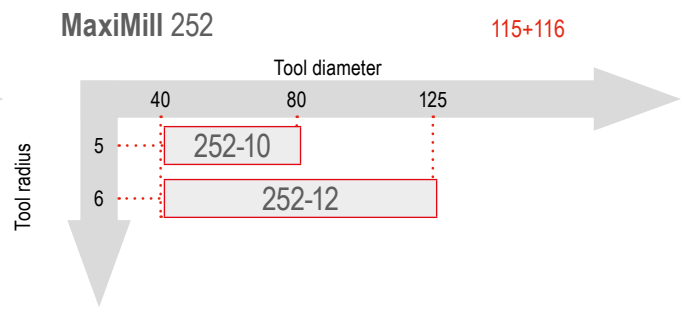
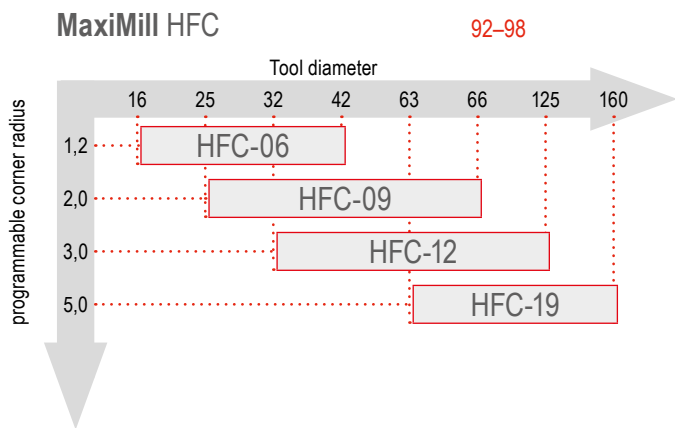







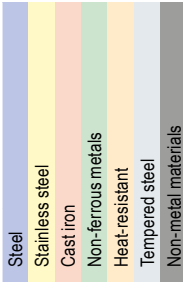









 This article can be found in our online shop at cuttingtools.ceratizit.com

Toolfinder – form milling



Application range
Tool diameter

Overview – form milling

System	Inserts	Cutting edges per insert	a_p max. mm	Ø-range mm			Material Compatibility	Page No.
MaxiMill HFC	X.LX 06.. / 09.. / 12.. / 19..	4	0,8–3,3	 Ø 16–42	 Ø 16–35	 Ø 32–160		92–98
MaxiMill DHFC	LNKX 09..	4	0,75	 Ø 16–42	 Ø 16–20			99+100
MaxiMill 251 RS	R..X 05.. / 08.. / 10.. / 12.. / 16.. / 20..	8	2,5–10	 Ø 10–42	 Ø 10–32	 Ø 40–125		101–109
R100.	RD.X 07.. / 10.. / 12.. / 16..	8	5	 Ø 15–42	 Ø 15–20	 Ø 42–160		110–114
MaxiMill 252	RNHU 10.. / 12..	8	3			 Ø 40–125		115+116
K200. Ball Nosed	RO.X / XOHX	1	0,4–8	 Ø 8–32	 Ø 6–32			117–121
K200. Torus	XO.X	1	0,5–8	 Ø 8–32	 Ø 8–32			122–125

 Additional diameters are available upon request.

 Indexable inserts for systems that are no longer listed here can be found in our online shop at cuttingtools.ceratizit.com

Overview – Chamfer / Angle Milling Cutters

System	Inserts	Cutting edges per insert	$a_{p \max}$ mm	\emptyset -range mm		Page No.
MaxiMill 272	SD.. 0903..	4	4	 \emptyset 6–25		38–40
MaxiMill 242	LD.. 1504..	2		 \emptyset 50–92		90+91
MaxiMill 490	SD.. 09T3.. / 1205..	4	6–11	 \emptyset 20,1–31,5		78–81

Additional diameters are available upon request.

Overview – Saw cutters

System	Inserts	Cutting edges per insert	$a_{p \max}$ mm	\emptyset -range mm		Page No.
MaxiMill Slot-SX	SX E...	1	115	 \emptyset 63–100 \emptyset 80–315		126–141
TX	TX.. R/L	3	64	 \emptyset 80–160 \emptyset 100–200		142–144

Additional diameters are available upon request.

MaxiMill – 274-04/-09 Screw in cutter

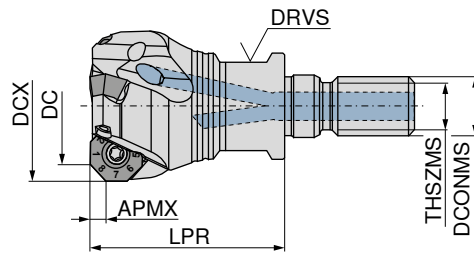
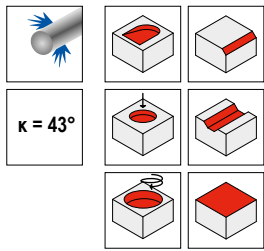

50 742 ...

Designation	DC mm	DCX mm	ZNF	APMX mm	LPR mm	THSZMS mm	DCONMS mm	DRVS mm	torque moment Nm	Insert
G274.20.R.03-09	20	25,8	3	3,8	35	M12	12,5	17	1,2	OF.. 0403 / SF.. 0903
G274.25.R.04-09	25	30,8	4	3,8	35	M12	12,5	17	1,2	OF.. 0403 / SF.. 0903
G274.32.R.05-09	32	37,9	5	3,8	35	M16	17,0	24	1,2	OF.. 0403 / SF.. 0903

020
025
032

MaxiMill – 274-04/-09 End milling cutter

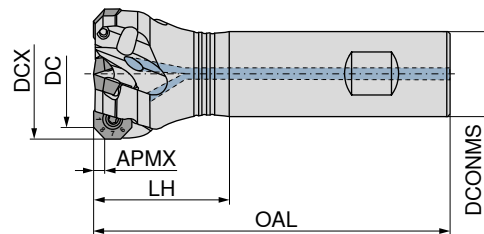
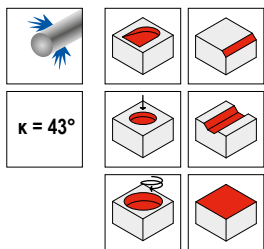

50 743 ...

50 743 ...

Designation	DC mm	DCX mm	ZNF	APMX mm	OAL mm	LH mm	DCONMS mm	torque moment Nm	Insert
C274.20.R.03-09-A/B20-25	20	25,8	3	3,8	77	25	20	1,2	OF.. 0403 / SF.. 0903
C274.25.R.04-09-A/B20-32	25	30,8	4	3,8	84	32	20	1,2	OF.. 0403 / SF.. 0903
C274.32.R.05-09-A/B25-40	32	37,9	5	3,8	98	40	25	1,2	OF.. 0403 / SF.. 0903

020
025
032

120
125
132

MaxiMill – 274-04/-09 Shell mill

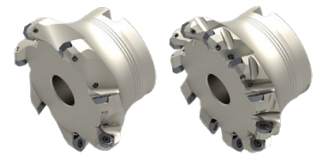
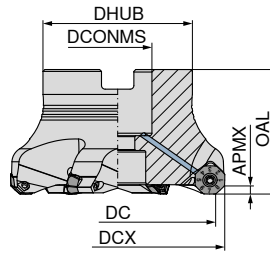
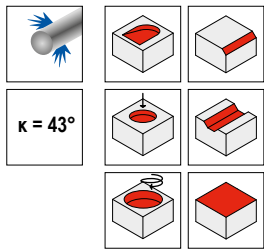

Designation	DC mm	DCX mm	ZNF	APMX mm	OAL mm	DHUB mm	DCONMS _{H6} mm	torque moment Nm	Insert	50 744 ...	
										040	032
A274.32.R.05-09	32	37,9	5	3,8	40	38	16	1,6	OF.. 0403 / SF.. 0903		032
A274.40.R.04-09	40	46,0	4	3,8	40	38	16	1,6	OF.. 0403 / SF.. 0903	040	
A274.40.R.06-09	40	46,0	6	3,8	40	38	16	1,6	OF.. 0403 / SF.. 0903		140
A274.50.R.05-09	50	55,9	5	3,8	40	48	22	1,6	OF.. 0403 / SF.. 0903	050	
A274.50.R.07-09	50	55,9	7	3,8	40	48	22	1,6	OF.. 0403 / SF.. 0903		150
A274.63.R.06-09	63	68,9	6	3,8	40	48	22	1,6	OF.. 0403 / SF.. 0903	063	
A274.63.R.09-09	63	68,9	9	3,8	40	48	22	1,6	OF.. 0403 / SF.. 0903		163
A274.80.R.07-09	80	85,9	7	3,8	50	58	27	1,6	OF.. 0403 / SF.. 0903	080	
A274.80.R.11-09	80	85,9	11	3,8	50	58	27	1,6	OF.. 0403 / SF.. 0903		180
A274.100.R.09-09	100	105,9	9	3,8	50	78	32	1,6	OF.. 0403 / SF.. 0903	100	
A274.100.R.13-09	100	105,9	13	3,8	50	78	32	1,6	OF.. 0403 / SF.. 0903		200
A274.125.R.12-09	125	130,9	12	3,8	63	88	40	1,6	OF.. 0403 / SF.. 0903	125	

Spare parts	TORX® blade	Clamping key – T	Key D	Power Screw	Molykote	Clamping screw	Torque screwdriver
	80 950 ...	80 397 ...	80 950 ...	70 950 ...	70 950 ...	70 950 ...	80 950 ...
DC							
20 - 32		043			303	133	191
32 - 40		043	040		303	133	191
50 - 125		043		151	303	133	191

Two insert types – ONE Cutter



OFHT / OFHW / SFHT / SFKT

Designation	IC mm	D1 mm	L mm	BS mm	S mm	AN °
OFH. 0403..	9,52	3,35	3,94	-	3,18	25
SF.T 0903..	9,80	3,35	9,00	2,25	3,50	25

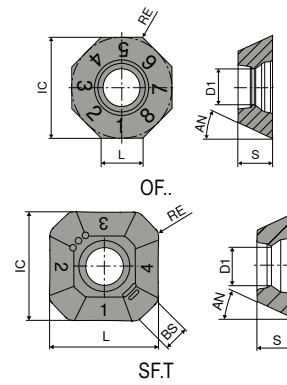

OFHT

-F50 CTCP230 DRAGONSKIN	-M50 CTCP230 DRAGONSKIN	-F50 CTPP235 DRAGONSKIN	-M50 CTPP235 DRAGONSKIN
F OFHT	M OFHT	F OFHT	M OFHT
51 002 ...	51 003 ...	51 002 ...	51 003 ...
005	005	105	105

ISO	RE mm
040305SN	0,5

P	●	●	●	●
M	○	○	○	○
K	○	○	○	○
N				
S				
H				
O				







OFHT / OFHW

-F50 CTCM235 DRAGONSKIN	-F50 CTPM240 DRAGONSKIN	-M50 CTPM240 DRAGONSKIN	-F50 CTPM245 DRAGONSKIN	CTPM245 DRAGONSKIN	-F50 CTCM245 DRAGONSKIN	CTCM245 DRAGONSKIN
F OFHT	F OFHT	M OFHT	F OFHT	F OFHW	F OFHT	F OFHW
51 002 ...	51 002 ...	51 003 ...	51 002 ...	51 105 ...	51 002 ...	51 105 ...
305	405	405	455	452	90501	90201

ISO	RE mm
040302EN	0,2
040305SN	0,5

P	●	○	○	●	●	●	●
M	●	●	●	●	●	●	●
K							
N							
S					○	○	
H							
O							

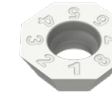
OFHT / OFHW

ISO		RE	NEW					
		mm	-M50 CTCK215	-F10 CTPX715	-F10 CTWN215	-F50 CTC5240	CTC5240	-F50 CTCS245
			DRAGONSKIN	DRAGONSKIN		DRAGONSKIN	DRAGONSKIN	DRAGONSKIN
								
			M	F	F	F	F	F
			OFHT	OFHT	OFHT	OFHT	OFHW	OFHT
			51 003 ...	51 122 ...	50 459 ...	51 002 ...	50 457 ...	51 002 ...
ISO	RE	mm						
040302EN	0,2							
040305FN	0,5							
040305SN	0,5		505	00502	505	15500	504	555
P				○				
M				○				
K			●	●	○			
N				●	●			
S				○		●	●	●
H								
O				○	○			

SFHT / SFKT

ISO		RE	NEW	
		mm	-F50 CTPP225	-M50 CTPP225
			DRAGONSKIN	DRAGONSKIN
				
			F	M
			SFHT	SFKT
			51 012 ...	51 013 ...
ISO	RE	mm		
0903AFSR	1			
			070	070
P			●	●
M				
K				
N				
S				
H				
O				





SFHT / SFKT

ISO	RE mm	-F50 CTCP230 DRAGONSKIN F SFHT 51 012 ... 020	-M50 CTCP230 DRAGONSKIN M SFKT 51 013 ... 020	-F50 CTPP235 DRAGONSKIN F SFHT 51 012 ... 120	-M50 CTPP235 DRAGONSKIN M SFKT 51 013 ... 120
P		●	●	●	●
M				○	○
K		○	○	○	○
N					
S					
H					
O					

SFHT / SFKT

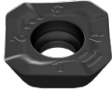
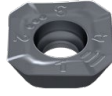
ISO	RE mm	-F50 CTCM235 DRAGONSKIN F SFHT 51 012 ... 320	-F50 CTPM240 DRAGONSKIN F SFHT 51 012 ... 420	-M50 CTPM240 DRAGONSKIN M SFKT 51 013 ... 42000	-F50 CTPM245 DRAGONSKIN F SFHT 51 012 ... 470	-F50 CTCM245 DRAGONSKIN F SFHT 51 012 ... 92001
P		●	○	○	●	●
M		●	●	●	●	●
K						
N						
S						○
H						
O						

SFKT / SFHT

		-R50		NEW -F10	-F10		-F40		
		CTCK215		CTPX715	CTWN215		CTC5240		
		DRAGONSKIN		DRAGONSKIN	DRAGONSKIN		DRAGONSKIN		
									
		R		F	F		F		
		SFKT		SFHT	SFHT		SFHT		
		51 065 ...		51 123 ...	50 514 ...		50 514 ...		
ISO	RE mm	520		620	01502		505		504
0903AFFR	1								
0903AFSR	1								
P					○				
M					○				
K		●		●	●		○		
N					●		●		
S					○				●
H									
O					○		○		

Milling guide



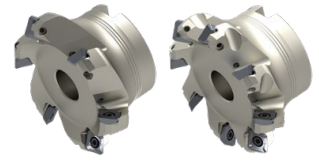
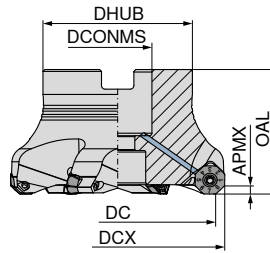
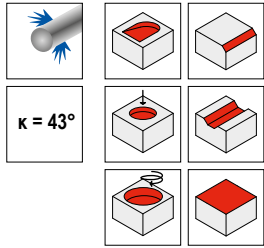

Cutting data standard values	→ 145-148	Machining strategy	→ 149
Starting Parameter	→ 150	Technical Information	→ 193-198
Chip groove description and overview	→ 199-201	Grade description and overview	→ 202-208

MaxiMill – 274-05/-12 Shell mill



Designation	DC mm	DCX mm	ZNF	APMX mm	OAL mm	DHUB mm	DCONMS _{H6} mm	torque moment Nm	Insert	50 772 ...	50 772 ...
										24000	04000
A274.40.R.03-12	40	48,0	3	6	40	38	16	3,2	OFHT 0504 / SFKT 1204		
A274.40.R.04-12	40	48,0	4	6	40	38	16	3,2	OFHT 0504 / SFKT 1204		
A274.50.R.04-12	50	58,0	4	6	40	43	22	3,2	OFHT 0504 / SFKT 1204	25000	050
A274.50.R.05-12	50	58,0	5	6	40	43	22	3,2	OFHT 0504 / SFKT 1204		
A274.63.R.05-12	63	71,1	5	6	40	48	22	3,2	OFHT 0504 / SFKT 1204	26300	063
A274.63.R.06-12	63	71,1	6	6	40	48	22	3,2	OFHT 0504 / SFKT 1204		
A274.80.R.06-12	80	88,0	6	6	50	58	27	3,2	OFHT 0504 / SFKT 1204	28000	080
A274.80.R.08-12	80	88,0	8	6	50	58	27	3,2	OFHT 0504 / SFKT 1204		
A274.100.R.08-12	100	108,0	8	6	50	78	32	3,2	OFHT 0504 / SFKT 1204	30000	100
A274.100.R.10-12	100	108,0	10	6	50	78	32	3,2	OFHT 0504 / SFKT 1204		
A274.125.R.09-12	125	133,0	9	6	63	88	40	3,2	OFHT 0504 / SFKT 1204	32500	125
A274.125.R.12-12	125	133,0	12	6	63	88	40	3,2	OFHT 0504 / SFKT 1204		
A274.160.R.11-12	160	168,0	11	6	63	98	40	3,2	OFHT 0504 / SFKT 1204	36000 ¹⁾	16000 ¹⁾
A274.160.R.14-12	160	168,0	14	6	63	98	40	3,2	OFHT 0504 / SFKT 1204		

1) With threaded holes M12 on the front face, pitch circle diameter = 66.7 mm / Without Through Coolant

				
TORX® blade	Key D	Molykote	Clamping screw	Torque screwdriver
80 950 ...	80 950 ...	70 950 ...	70 950 ...	80 950 ...
054	128	303	340	193

Spare parts
DC

40 - 160

Two insert types – ONE Cutter

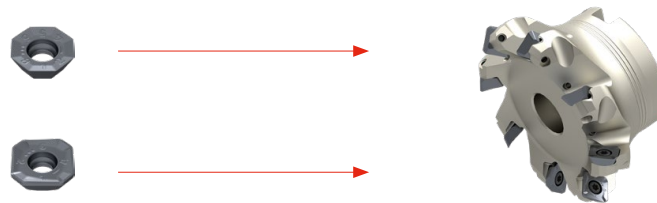

OFHT / SFHT / SFKT

Designation	IC mm	D1 mm	L mm	BS mm	S mm	AN °
OFHT 0504..	12,7	4,8	4,5	-	4,76	25
SF.T 1204..	12,7	4,8	12,7	1,42	4,76	25

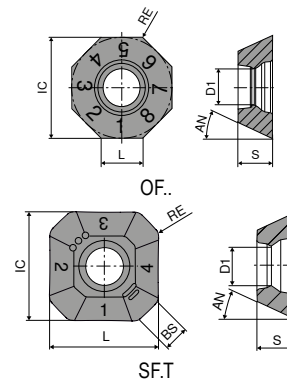

OFHT

-F50 CTCP230 DRAGONSKIN	-M50 CTCP230 DRAGONSKIN	-F50 CTPP235 DRAGONSKIN	-M50 CTPP235 DRAGONSKIN
F OFHT	M OFHT	F OFHT	M OFHT
51 002 ...	51 003 ...	51 002 ...	51 003 ...
010	01000	110	11000

ISO	RE mm
050410SN	1

P	●	●	●	●
M	○	○	○	○
K	○	○	○	○
N				
S				
H				
O				



OFHT

-F50 CTCM235 DRAGONSKIN	-F50 CTPM240 DRAGONSKIN	-M50 CTPM240 DRAGONSKIN	-F50 CTPM245 DRAGONSKIN
F OFHT	F OFHT	M OFHT	F OFHT
51 002 ...	51 002 ...	51 003 ...	51 002 ...
310	410	41000	460

ISO	RE mm
050410SN	1

P	●	○	○	●
M	●	●	●	●
K				
N				
S				
H				
O				

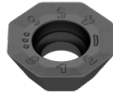

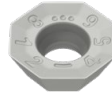
OFHT

	NEW		
-F50 CTCM245	-F10 CTPX715	-F10 CTWN215	-F50 CTC5240
DRAGONSKIN	DRAGONSKIN		DRAGONSKIN
			
F OFHT	F OFHT	F OFHT	F OFHT
51 002 ...	51 122 ...	51 122 ...	51 002 ...
91001	01002	36000	16000

ISO	RE mm
050410FN	1
050410SN	1

P	●	○		
M	●	○		
K		●	○	
N		●	●	
S	○	○		●
H				
O		○	○	

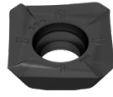
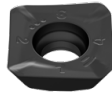
SFHT / SFKT

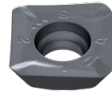
-F50 CTCP230	-M50 CTCP230	-F50 CTPP235	-M50 CTPP235
DRAGONSKIN	DRAGONSKIN	DRAGONSKIN	DRAGONSKIN
			
F SFHT	M SFKT	F SFHT	M SFKT
51 012 ...	51 013 ...	51 012 ...	51 013 ...
02500	025	12500	125

ISO	RE mm
1204AFSR	1

P	●	●	●	●
M			○	○
K	○	○	○	○
N				
S				
H				
O				

SFHT / SFKT

ISO	RE mm	-F50 CTCM235 DRAGONSKIN F SFHT 51 012 ... 325	-M50 CTCM235 DRAGONSKIN M SFKT 51 013 ... 325	-F50 CTPM240 DRAGONSKIN F SFHT 51 012 ... 42500	-M50 CTPM240 DRAGONSKIN M SFKT 51 013 ... 425
P		●	●	○	○
M		●	●	●	●
K					
N					
S					
H					
O					

SFHT

ISO	RE mm	-F50 CTPM245 DRAGONSKIN F SFHT 51 012 ... 47500	-F50 CTCM245 DRAGONSKIN F SFHT 51 012 ... 92501	NEW -F10 CTPX715 DRAGONSKIN F SFHT 51 123 ... 02502	-F10 CTWN215 DRAGONSKIN F SFHT 51 123 ... 37000	-F40 CTC5240 DRAGONSKIN F SFHT 50 514 ... 50900
P		●	●	○	○	○
M		●	●	○	○	○
K				●	○	○
N				●	●	○
S			○	○	○	●
H						
O				○	○	

Milling guide

Cutting data standard values	→ 145-148	Machining strategy	→ 151
Starting Parameter	→ 152	Technical Information	→ 193-198
Chip groove description and overview	→ 199-201	Grade description and overview	→ 202-208

MaxiMill – 271-12 End milling cutter

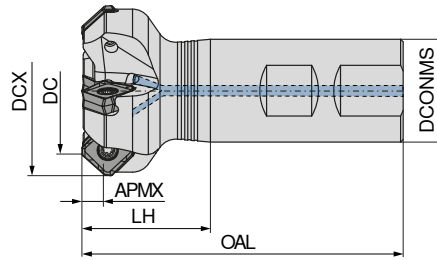
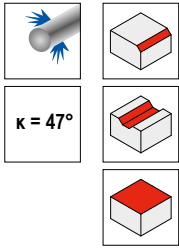





50 786 ...

Designation	DC mm	DCX mm	ZNF	APMX mm	OAL mm	LH mm	DCONMS _{h6} mm	RPMX 1/min.	torque moment Nm	Insert	
C271.32.R.03-12-B-40	32	45	3	6,8	100	40	32	18400	3,2	SOHU 1204.. / XOHU 1204..	03203
C271.40.R.04-12-B32-40	40	53	4	6,8	100	40	32	16800	3,2	SOHU 1204.. / XOHU 1204..	04004

Spare parts
DC

32 - 40

 TORX® blade	 Key D	 Molykote	 Clamping screw	 Torque screwdriver
80 950 ...	80 950 ...	70 950 ...	70 950 ...	80 950 ...
054	120	303	859	193

MaxiMill – 271-12 Face mill

▲ 8 cutting edges per insert

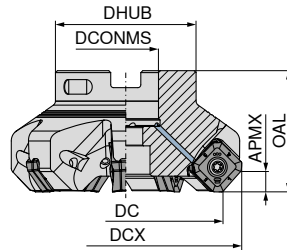
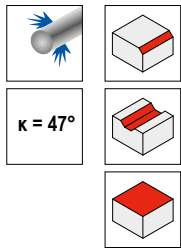

Designation	DC mm	DCX mm	ZNF	APMX mm	OAL mm	DHUB mm	DCONMS _{H6} mm	RPMX 1/min.	torque moment Nm	Insert	50 787 ...	
											04004	05005
A271.40.R.04-12	40	53	4	6,8	40	38	16	17900	3,2	SOHU 1204.. / XOHU 1204..		04004
A271.50.R.05-12	50	63	5	6,8	40	43	22	15200	3,2	SOHU 1204.. / XOHU 1204..		05005
A271.63.R.07-12	63	76	7	6,8	40	48	22	13100	3,2	SOHU 1204.. / XOHU 1204..		06307
A271.80.R.06-12	80	93	6	6,8	50	58	27	11300	3,2	SOHU 1204.. / XOHU 1204..	08006	
A271.80.R.08-12	80	93	8	6,8	50	58	27	11300	3,2	SOHU 1204.. / XOHU 1204..		08008
A271.100.R.07-12	100	113	7	6,8	63	78	32	9900	3,2	SOHU 1204.. / XOHU 1204..	10007	
A271.100.R.10-12	100	113	10	6,8	63	78	32	9900	3,2	SOHU 1204.. / XOHU 1204..		10010
A271.125.R.08-12	125	138	8	6,8	63	88	40	8700	3,2	SOHU 1204.. / XOHU 1204..	12508	
A271.125.R.12-12	125	138	12	6,8	63	88	40	8700	3,2	SOHU 1204.. / XOHU 1204..		12512
A271.160.R.09-12	160	173	9	6,8	63	98	40	7600	3,2	SOHU 1204.. / XOHU 1204..	16009 ¹⁾	
A271.160.R.14-12	160	173	14	6,8	63	98	40	7600	3,2	SOHU 1204.. / XOHU 1204..		16014 ¹⁾
A271.200.R.11-12	200	213	11	6,8	63	132	60	6700	3,2	SOHU 1204.. / XOHU 1204..	20011 ²⁾	
A271.200.R.17-12	200	213	17	6,8	63	132	60	6700	3,2	SOHU 1204.. / XOHU 1204..		20017 ²⁾
A271.250.R.13-12	250	263	13	6,8	63	132	60	6000	3,2	SOHU 1204.. / XOHU 1204..	25013 ²⁾	
A271.250.R.21-12	250	263	21	6,8	63	132	60	6000	3,2	SOHU 1204.. / XOHU 1204..		25021 ²⁾

- 1) With threaded holes M12 on the front face, pitch circle diameter = 66.7 mm / Without Through Coolant
- 2) With threaded holes M16 on the front face, pitch circle diameter = 101.6 mm / Without Through Coolant

MaxiMill – 271-12 HFC Face mill

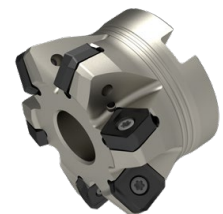
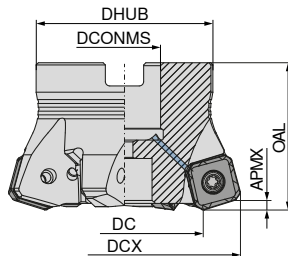
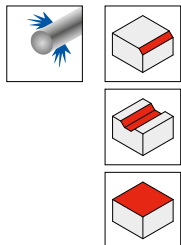

Designation	DC mm	DCX mm	ZNF	APMX mm	OAL mm	DHUB mm	DCONMS _{H6} mm	RPMX 1/min.	torque moment Nm	Insert	50 788 ...	
											05004	06306
A271.50.R.04-12-HFC	30	50	4	2,6	40	43	22	14600	3,2	SOHU 1204..		05004
A271.63.R.06-12-HFC	43	63	6	2,6	40	48	22	12500	3,2	SOHU 1204..		06306
A271.80.R.07-12-HFC	60	80	7	2,6	50	58	27	10800	3,2	SOHU 1204..		08007

Spare parts

DC	TORX® blade	Clamping key – T	Key D	Power Screw	Molykote	Clamping screw	Torque screwdriver
40 (5078704004)	80 950 ...	80 397 ...	80 950 ...	70 950 ...	70 950 ...	70 950 ...	80 950 ...
50 - 250	054	040	120	151	303	859	193
50 (5078805004)	054	050	120	154	303	859	193

SOHU

Designation	IC mm	D1 mm	L mm	BS mm	S mm	AN °
SOHU 1204..	13,36	4,4	8,8	1,7	5,00	7,4

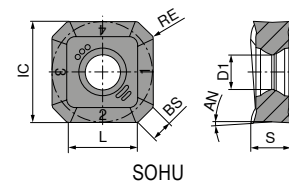

SOHU

ISO	RE mm	-M50 CTCP230	-M50 CTPP235	-M50 CTCM235	-M50 CTPM240	-F50 CTPM245	-F50 CTCM245
1204ABSR	0,8	02000	12000	32000	42000	47000	92001
P		●	●	●	○	●	●
M		○	○	●	●	●	●
K		○	○				
N							
S							○
H							
O							

SOHU

ISO	RE mm	-R50 CTCK215	-R50 CTPK220	-F40 CTC5240	-F50 CTC5240
1204ABSR	0,8	52000	62000	12001	17000
P					
M					
K			●	●	
N					
S				●	●
H					
O					

XOHU

Designation	IC mm	D1 mm	L mm	BS mm	S mm
XOHU 1204..	13,36	4,4	8,8	1,83	5,00

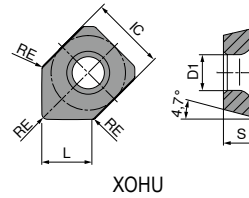

XOHU

▲ Masterfinish indexable insert (sweeper insert)

-M50
CTPP235

DRAGONSKIN

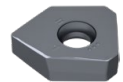

XOHU

51 141 ...

ISO	RE mm
1204ABSR	0,8

12000

P	●
M	○
K	○
N	
S	
H	
O	

Milling guide

Cutting data standard values	→ 145-148	Starting Parameter	→ 153
Technical Information	→ 193-198	Chip groove description and overview	→ 199-201
Grade description and overview	→ 202-208		

MaxiMill – 271-17 Face mill



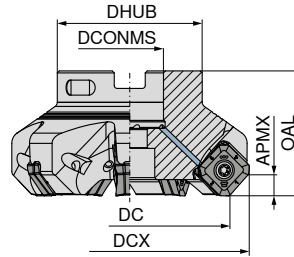
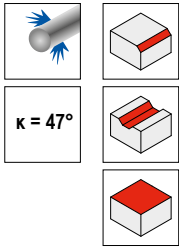

▲ 8 cutting edges per insert



50 767 ...

Designation	DC mm	DCX mm	ZNF	APMX mm	OAL mm	DCONMS mm	DHUB mm	torque moment Nm	Insert	
A271.50.R.04-17	50	66,1	4	8,4	40	22	43	5	SAKU 1706	050
A271.63.R.06-17	63	79,1	6	8,4	40	22	48	5	SAKU 1706	063
A271.80.R.07-17	80	96,1	7	8,4	50	27	58	5	SAKU 1706	080
A271.100.R.08-17	100	116,1	8	8,4	50	32	78	5	SAKU 1706	100
A271.125.R.10-17	125	141,1	10	8,4	63	40	88	5	SAKU 1706	125
A271.160.R.12-17	160	176,1	12	8,4	63	40	104	5	SAKU 1706	16000 ¹⁾
A271.200.R.13-17	200	216,1	13	8,4	63	60	134	5	SAKU 1706	20000 ²⁾
A271.250.R.15-17	250	266,1	15	8,4	63	60	134	5	SAKU 1706	25000 ²⁾

- 1) With threaded holes M12 on the front face, pitch circle diameter = 66.7 mm / Without Through Coolant
- 2) With threaded holes M16 on the front face, pitch circle diameter = 101.6 mm / Without Through Coolant

 TORX® blade	 Key D	 Molykote	 Clamping screw	 Torque screwdriver
80 950 ...	80 950 ...	70 950 ...	70 950 ...	80 950 ...
037	114	303	302	193

Spare parts

DC
50 - 250

SAKU

Designation	IC mm	D1 mm	L mm	BS mm	S mm	AN °
SAKU 1706..	17	5,8	11,85	3,7	6,35	3

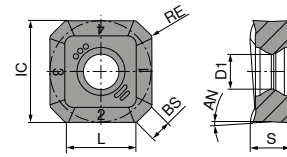

SAKU

SAKU

-F50 CTCP220	-M50 CTCP220	-F50 CTPP225	-M50 CTPP225
DRAGONSKIN	DRAGONSKIN	DRAGONSKIN	DRAGONSKIN
SAKU	SAKU	SAKU	SAKU
51 004 ...	51 005 ...	51 004 ...	51 005 ...
270	270	070	070

ISO	RE mm
1706ABSR	0,8

P	•	•	•	•
M				
K				
N				
S				
H				
O				

SAKU

-F50 CTCP230	-M50 CTCP230	-F50 CTPP235	-M50 CTPP235
DRAGONSKIN	DRAGONSKIN	DRAGONSKIN	DRAGONSKIN
SAKU	SAKU	SAKU	SAKU
51 004 ...	51 005 ...	51 004 ...	51 005 ...
020	020	120	120

ISO	RE mm
1706ABSR	0,8

P	•	•	•	•
M			○	○
K	○	○	○	○
N				
S				
H				
O				

SAKU

ISO	RE mm	-F50 CTPM225 DRAGONSKIN	-M50 CTPM225 DRAGONSKIN	-F50 CTCM235 DRAGONSKIN	-M50 CTCM235 DRAGONSKIN	-F50 CTPM240 DRAGONSKIN	-M50 CTPM240 DRAGONSKIN	-F50 CTPM245 DRAGONSKIN
1706ABSR	0,8	SAKU 51 004 ...	SAKU 51 005 ...	SAKU 51 004 ...	SAKU 51 005 ...	SAKU 51 004 ...	SAKU 51 005 ...	SAKU 51 004 ...
		220	220	320	320	420	420	470
P		●	●	●	●	○	○	●
M		●	●	●	●	●	●	●
K								
N								
S								
H								
O								

SAKU

ISO	RE mm	-F50 CTCM245 DRAGONSKIN	-M50 CTCK215 DRAGONSKIN	-R50 CTCK215 DRAGONSKIN	-M50 CTPK220 DRAGONSKIN	-R50 CTPK220 DRAGONSKIN	-F50 CTC5240 DRAGONSKIN	-F50 CTCS245 DRAGONSKIN
1706ABSR	0,8	SAKU 51 004 ...	SAKU 51 005 ...	SAKU 51 058 ...	SAKU 51 005 ...	SAKU 51 058 ...	SAKU 50 306 ...	SAKU 51 004 ...
		92001	520	520	620	620	520	570
P		●						
M		●						
K			●	●	●	●		
N								
S		○					●	●
H								
O								

Milling guide

Cutting data standard values	→ 145-148	Starting Parameter	→ 153
Technical Information	→ 193-198	Chip groove description and overview	→ 199-201
Grade description and overview	→ 202-208		

MaxiMill – 273-06 Shell mill

▲ 16 cutting edges per insert

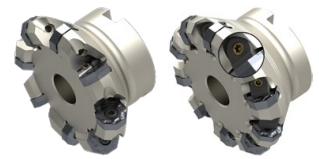
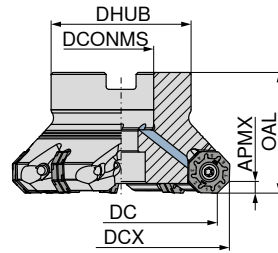
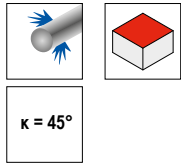

Designation	DC mm	DCX mm	ZNF	APMX mm	OAL mm	DCONMS mm	DHUB mm	torque moment Nm	Insert	50 741 ...	
A273.40.R.03-06	40	50,2	3	3,5	40	16	38	5	OAKU / XAHT 0605	040	
A273.40.R.04-06	40	50,2	4	3,5	40	16	38	5	OAKU / XAHT 0605	140 ⁵⁾	
A273.50.R.05-06	50	60,2	5	3,5	40	22	43	5	OAKU / XAHT 0605	050	
A273.63.R.07-06	63	73,2	7	3,5	40	22	48	5	OAKU / XAHT 0605	063	
A273.80.R.08-06	80	90,2	8	3,5	50	27	58	5	OAKU / XAHT 0605	080	
A273.80.R.10-06	80	90,2	10	3,5	50	27	58	4	OAKU / XAHT 0605		180 ¹⁾
A273.100.R.10-06	100	110,2	10	3,5	50	32	78	5	OAKU / XAHT 0605	100	
A273.100.R.14-06	100	110,2	14	3,5	50	32	78	4	OAKU / XAHT 0605		200 ¹⁾
A273.125.R.12-06	125	135,2	12	3,5	63	40	88	5	OAKU / XAHT 0605	125	
A273.125.R.17-06	125	135,2	17	3,5	63	40	88	4	OAKU / XAHT 0605		225 ¹⁾
A273.160.R.14-06	160	170,2	14	3,5	63	40	104	5	OAKU / XAHT 0605	160 ⁴⁾	
A273.160.R.20-06	160	170,2	20	3,5	63	40	104	4	OAKU / XAHT 0605		260 ²⁾
A273.200.R.25-06	200	210,2	25	3,5	63	60	153	4	OAKU / XAHT 0605		300 ³⁾
A273.250.R.31-06	250	260,2	31	3,5	63	60	153	4	OAKU / XAHT 0605		25031 ³⁾

- 1) Version with Wedge, without internal coolant supply
- 2) Version with Wedge, without internal coolant supply / With threaded holes M12 on the front face, pitch circle diameter = 66.7 mm
- 3) Version with Wedge, without internal coolant supply / With threaded holes M16 on the front face, pitch circle diameter = 101.6 mm
- 4) With threaded holes M12 on the front face, pitch circle diameter = 66.7 mm / Without Through Coolant
- 5) Without Through Coolant

Spare parts DC	TORX® blade	Clamping key – T	Clamping wedge screw	Clamping wedge Face mill	Key D	Power Screw	Clamping screw	Torque screwdriver
	80 950 ...	80 397 ...	70 950 ...	70 950 ...	80 950 ...	70 950 ...	70 950 ...	80 950 ...
40					114	151	302	193
50	037				114	154	302	193
63 - 80	037	040			114		302	193
80 - 100	036			844	845			193
100 - 125	037				114		302	193
125	036			844	845			193
160	037				114		302	193
160 - 250	036			844	845			193

MaxiMill – 273-06 Shell mill

- ▲ 16 cutting edges per indexable insert
- ▲ Axially adjustable

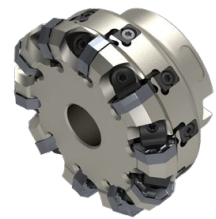
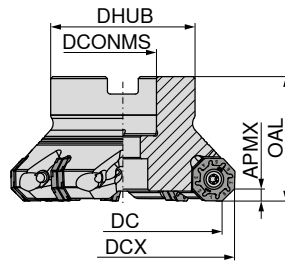
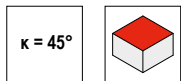

50 777 ...

Designation	DC mm	DCX mm	ZNF	APMX mm	OAL mm	DCONMS _{H6} mm	DHUB mm	torque moment Nm	Insert	
A273.80.R.10A10-06	80	90,2	10	3,5	50	27	58	4	OAKU / XAHT 0605	08010 ¹⁾
A273.100.R.14A14-06	100	110,2	14	3,5	50	32	78	4	OAKU / XAHT 0605	10014 ¹⁾
A273.125.R.17A17-06	125	135,2	17	3,5	63	40	88	4	OAKU / XAHT 0605	12517 ¹⁾
A273.160.R.20A20-06	160	170,2	20	3,5	63	40	104	4	OAKU / XAHT 0605	16020 ²⁾
A273.200.R.25A25-06	200	210,2	25	3,5	63	60	153	4	OAKU / XAHT 0605	20025 ³⁾
A273.250.R.31A31-06	250	260,2	31	3,5	63	60	153	4	OAKU / XAHT 0605	25031 ³⁾

- 1) Version with Wedge
- 2) Version with Wedge / With threaded holes M12 on the front face, pitch circle diameter = 66.7 mm
- 3) Version with Wedge / With threaded holes M16 on the front face, pitch circle diameter = 101.6 mm

Spare parts	TORX® blade	Clamping wedge screw	Clamping wedge Face mill	Key D	Molykote	Wedge	Torque screwdriver
DC	80 950 ...	70 950 ...	70 950 ...	80 950 ...	70 950 ...	70 950 ...	80 950 ...
80 - 250	036	844	845	113	303	199	193

OAKU / XAHT

Designation	IC mm	D1 mm	L mm	BS mm	S mm	AN °
XAHT 0605..	17,08	6,0	-	11,95	5,56	3
OAKU 0605..	17,10	5,8	6	2,00	5,66	3

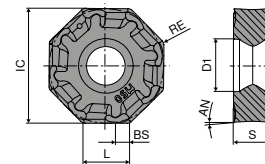

OAKU

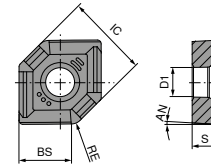

XAHT

OAKU

-F50 CTCP220	-M50 CTCP220	-F50 CTPP225	-M50 CTPP225
DRAGONSKIN	DRAGONSKIN	DRAGONSKIN	DRAGONSKIN
OAKU	OAKU	OAKU	OAKU
51 000 ...	51 001 ...	51 000 ...	51 001 ...
258	258	058	058

ISO	RE mm
060508SR	0,8

P	•	•	•	•
M				
K				
N				
S				
H				
O				





OAKU

-F50 CTCP230	-M50 CTCP230	-F50 CTPP235	-M50 CTPP235
DRAGONSKIN	DRAGONSKIN	DRAGONSKIN	DRAGONSKIN
OAKU	OAKU	OAKU	OAKU
51 000 ...	51 001 ...	51 000 ...	51 001 ...
008	008	108	108



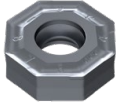

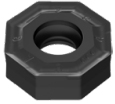
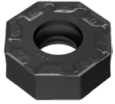

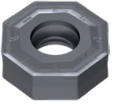
ISO	RE mm
060508SR	0,8

P	•	•	•	•
M				
K	○	○	○	○
N				
S				
H				
O				

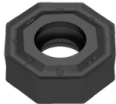
OAKU

		-F50 CTPM225	-M50 CTPM225	-F50 CTCM235	-M50 CTCM235	-F50 CTPM240	-M50 CTPM240	-F40 CTPM245
		DRAGONSKIN	DRAGONSKIN	DRAGONSKIN	DRAGONSKIN	DRAGONSKIN	DRAGONSKIN	DRAGONSKIN
								
		OAKU	OAKU	OAKU	OAKU	OAKU	OAKU	OAKU
		51 000 ...	51 001 ...	51 000 ...	51 001 ...	51 000 ...	51 001 ...	51 104 ...
ISO	RE mm							
060508ER	0,8							458
060508SR	0,8	208	208	308	308	408	408	
P		•	•	•	•	○	○	•
M		•	•	•	•	•	•	•
K								
N								
S								
H								
O								

OAKU

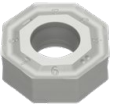
		-F40 CTCM245	-M50 CTCK215	-R50 CTCK215	-M50 CTPK220	-R50 CTPK220	-F40 CTC5240	-F40 CTCS245
		DRAGONSKIN	DRAGONSKIN	DRAGONSKIN	DRAGONSKIN	DRAGONSKIN	DRAGONSKIN	DRAGONSKIN
								
		OAKU	OAKU	OAKU	OAKU	OAKU	OAKU	OAKU
		51 104 ...	51 001 ...	51 027 ...	51 001 ...	51 027 ...	50 446 ...	51 104 ...
ISO	RE mm							
060508ER	0,8	90801					550	50801
060508SR	0,8		508	508	608	608		
P		•						
M		•						
K			•	•	•	•		
N								
S		○					•	•
H								
O								

XAHT

▲ Masterfinish indexable insert (sweeper insert)

ISO	RE mm	-M50 CTCP220 DRAGONSKIN XAHT 51 014 ... 275	-M50 CTPP225 DRAGONSKIN XAHT 51 014 ... 075	-M50 CTCP230 DRAGONSKIN XAHT 51 014 ... 025	-M50 CTPP235 DRAGONSKIN XAHT 51 014 ... 125
060525SR	2,5				
P		●	●	●	●
M					○
K				○	○
N					
S					
H					
O					

XAHT

▲ Masterfinish indexable insert (sweeper insert)

ISO	RE mm	-M50 CTPM225 DRAGONSKIN XAHT 51 014 ... 225	-M50 CTCM235 DRAGONSKIN XAHT 51 014 ... 325	-M50 CTPM240 DRAGONSKIN XAHT 51 014 ... 425	-M50 CTCK215 DRAGONSKIN XAHT 51 014 ... 525	-M50 CTPK220 DRAGONSKIN XAHT 51 014 ... 625
060525SR	2,5					
P		●	●	○		
M		●	●	●		
K					●	●
N						
S						
H						
O						

Milling guide

Cutting data standard values	→ 145–148	Starting Parameter	→ 154
Technical Information	→ 193–198	Chip groove description and overview	→ 199–201
Grade description and overview	→ 202–208		

MaxiMill – 273-08 Shell mill

▲ 16 cutting edges per insert

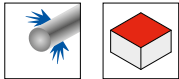

$\kappa = 45^\circ$

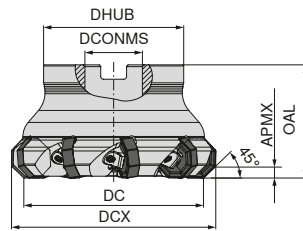

NEW

NEW

Designation	DC mm	DCX mm	ZNF	APMX mm	OAL mm	DCONMS _{H6} mm	DHUB mm	torque moment Nm	Insert	50 779 ...	50 779 ...
A273.63.R.05-08	63	76,7	5	5	50	22	48	5	ONKU 0806	06300	
A273.63.R.06-08	63	76,7	6	5	50	22	48	5	ONKU 0806		16300 ¹⁾
A273.80.R.06-08	80	93,7	6	5	50	27	58	5	ONKU 0806	08000	
A273.80.R.08-08	80	93,7	8	5	50	27	58	4	ONKU 0806		18000 ¹⁾
A273.100.R.07-08	100	113,7	7	5	63	32	78	5	ONKU 0806	10000	
A273.100.R.09-08	100	113,7	9	5	63	32	78	4	ONKU 0806		20000 ¹⁾
A273.125.R.08-08	125	138,7	8	5	63	40	88	5	ONKU 0806	12500	
A273.125.R.11-08	125	138,7	11	5	63	40	88	4	ONKU 0806		22500 ¹⁾
A273.160.R.10-08	160	173,7	10	5	63	40	98	5	ONKU 0806	16000 ³⁾	
A273.160.R.14-08	160	173,7	14	5	63	40	98	4	ONKU 0806		26000 ²⁾

- 1) Version with Wedge
- 2) Version with Wedge, without internal coolant supply / With threaded holes M12 on the front face, pitch circle diameter = 66.7 mm
- 3) With threaded holes M12 on the front face, pitch circle diameter = 66.7 mm / Without Through Coolant

TORX® blade	Clamping wedge screw	Clamping wedge Face mill	Key D	Molykote	Clamping screw	Torque screwdriver
80 950 ...	70 950 ...	70 950 ...	80 950 ...	70 950 ...	70 950 ...	80 950 ...

Spare parts for Article no.

50 779 06300	055			129	303	821	193
50 779 16300	036	844	845	113	303		193
50 779 08000	055			129	303	821	193
50 779 18000	036	844	845	113	303		193
50 779 10000	055			129	303	821	193
50 779 20000	036	844	845	113	303		193
50 779 12500	055			129	303	821	193
50 779 22500	036	844	845	113	303		193
50 779 16000	055			129	303	821	193
50 779 26000	036	844	845	113	303		193

ONKU

Designation	IC mm	D1 mm	L mm	S mm
ONKU 0806..	22	5,8	8,45	6,45

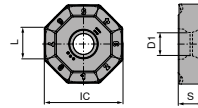

ONKU

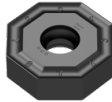
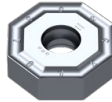
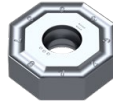
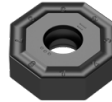
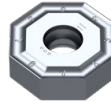
	NEW	NEW	NEW	NEW	NEW
	-M50 CTCP230	-M50 CTPP235	-M50 CTPM240	-M50 CTCK215	-M50 CTPK220
	DRAGONSKIN	DRAGONSKIN	DRAGONSKIN	DRAGONSKIN	DRAGONSKIN
					
	ONKU	ONKU	ONKU	ONKU	ONKU
	51 163 ...	51 163 ...	51 163 ...	51 163 ...	51 163 ...
ISO	RE mm				
080608SN	0,8	00800	10800	20800	50800 60800

P	●	●	○		
M		○	●		
K	○	○		●	●
N					
S					
H					
O					

ONKU

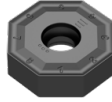
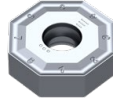
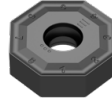
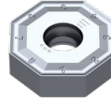
	NEW	NEW	NEW	NEW
	-R50 CTCP230	-R50 CTPP235	-R50 CTCK215	-R50 CTPK220
	DRAGONSKIN	DRAGONSKIN	DRAGONSKIN	DRAGONSKIN
				
	ONKU	ONKU	ONKU	ONKU
	51 164 ...	51 164 ...	51 164 ...	51 164 ...
ISO	RE mm			
080608SN	0,8	00800	10800	50800 60800

P	●	●		
M		○		
K	○	○	●	●
N				
S				
H				
O				

Milling guide

Cutting data standard values	→ 145-148	Starting Parameter	→ 155
Technical Information	→ 193-198	Chip groove description and overview	→ 199-201
Grade description and overview	→ 202-208		

MaxiMill – 270-09 End milling cutter

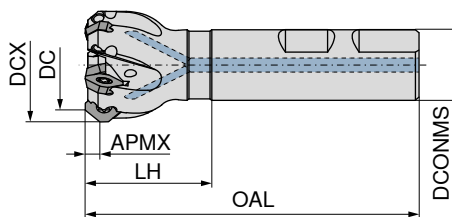
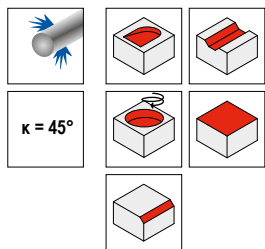

50 666 ...

Designation	DC mm	DCX mm	ZNF	APMX mm	OAL mm	LH mm	DCONMS	torque moment Nm	Insert
C270.06.R.01-09	6	14,4	1	4	80	32	16	1,2	SD.. 0903..
C270.12.R.01-09	12	20,4	1	4	80	32	16	1,2	SD.. 0903..
C270.16.R.02-09	16	24,4	2	4	90	40	20	1,8	SD.. 0903..
C270.20.R.03-09	20	28,4	3	4	90	40	20	1,8	SD.. 0903..
C270.25.R.04-09	25	33,4	4	4	100	44	25	1,8	SD.. 0903..
C270.32.R.05-09	32	40,4	5	4	95	36	25	1,8	SD.. 0903..

006
012
016
020
025
032

MaxiMill – 270-09 Shell mill

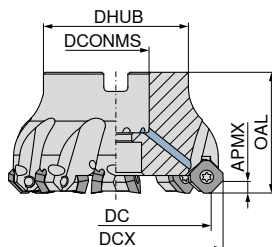
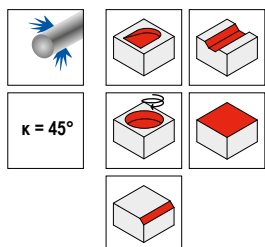

50 705 ...

50 706 ...

Designation	DC mm	DCX mm	ZNF	APMX mm	OAL mm	DHUB mm	DCONMS _{H6} mm	torque moment Nm	Insert
A270.32.R.05-09	32	40,4	5	4	40	34	16	1,8	SD../XD.. 0903..
A270.40.R.04-09	40	48,4	4	4	40	38	16	1,8	SD../XD.. 0903..
A270.40.R.06-09	40	48,4	6	4	40	38	16	1,8	SD../XD.. 0903..
A270.50.R.06-09	50	58,4	6	4	40	43	22	1,8	SD../XD.. 0903..
A270.50.R.08-09	50	58,4	8	4	40	43	22	1,8	SD../XD.. 0903..
A270.63.R.08-09	63	71,4	8	4	40	48	22	1,8	SD../XD.. 0903..
A270.63.R.10-09	63	71,4	10	4	40	48	22	1,8	SD../XD.. 0903..
A270.80.R.10-09	80	88,4	10	4	50	58	27	1,8	SD../XD.. 0903..
A270.80.R.12-09	80	88,4	12	4	50	58	27	1,8	SD../XD.. 0903..
A270.100.R.12-09	100	108,4	12	4	50	78	32	1,8	SD../XD.. 0903..
A270.100.R.14-09	100	108,4	14	4	50	78	32	1,8	SD../XD.. 0903..
A270.125.R.12-09	125	133,4	12	4	63	88	40	1,8	SD../XD.. 0903..

540
550
563
580
600
625

532
540
550
563
580
600



- ▲ 50 705 ... Normal pitch for a broad spectrum of use on aluminum alloys, non-ferrous metals, and soft steel materials
- ▲ 50 706 ... Fine pitch for highest feed rates, predominantly used on steel and cast materials

MaxiMill – 272-09 Chamfer milling cutter

▲ Usable on front and rear cutting edges

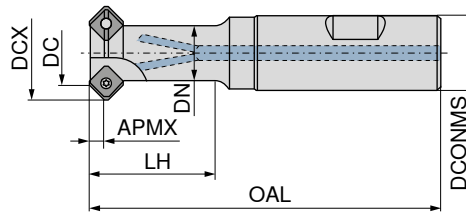
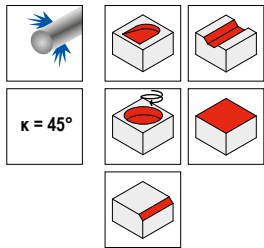

50 669 ...

Designation	DC mm	DCX mm	ZNF	APMX mm	DN mm	OAL mm	LH mm	DCONMS mm	torque moment Nm	Insert	
C272.06.R.01-09	6	14,4	1	4	10	91	24,0	16	1,2	SD.. 0903..	10600
C272.08.R.01-09	8	16,4	1	4	10	91	25,5	16	1,2	SD.. 0903..	008
C272.12.R.01-09	12	20,4	1	4	12	91	26,0	16	1,2	SD.. 0903..	012
C272.16.R.02-09	16	24,4	2	4	15	97	30,0	20	1,8	SD.. 0903..	016
C272.18.R.02-09	18	26,4	2	4	16	97	30,0	20	1,8	SD.. 0903..	018
C272.25.R.03-09	25	33,4	3	4	21	109	35,0	25	1,8	SD.. 0903..	025

Spare parts

DC	TORX® blade	Key D	Molykote	Clamping screw	Torque screwdriver
6 - 12	80 950 ...	80 950 ...	70 950 ...	70 950 ...	80 950 ...
16 - 25	033	110	303	365	191
	033	110	303	115	191

SDHW / SDNT / SDHT / XDHW

Designation	IC mm	D1 mm	L mm	BS mm	S mm
XDHW 0903..	9,52	3,4	5,50	1,68	3,18
SD.. 0903..	9,52	3,4	9,52	1,68	3,18

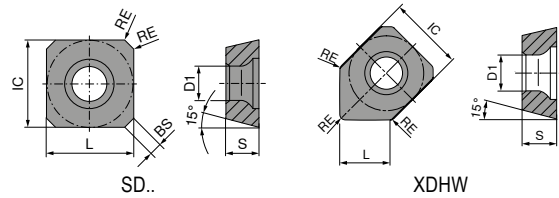

SDHW / SDNT / SDHT

ISO	RE mm	TCM10	-29 CTCP230 DRAGONSKIN	-29 CTPP235 DRAGONSKIN	-33 CTPM240 DRAGONSKIN	-33P CTPM240 DRAGONSKIN	-F50 CTPM245 DRAGONSKIN	-F50 CTCM245 DRAGONSKIN
		CERMET SDHW	SDNT	SDNT	SDHT	SDHT	SDHT	SDHT
		50 428 ...	51 011 ...	51 011 ...	51 028 ...	51 086 ...	51 109 ...	51 109 ...
0903AESN	1	898	020	120	420	420	470	92001
P		●	●	●	○	○	●	●
M				○	●	●	●	●
K		○	○	○				
N								
S								○
H								
O								

SDNT / SDHT

ISO	RE mm	-31 CTCK215 DRAGONSKIN	NEW -F10 CTPX715 DRAGONSKIN	-27P H216T	-M31 CTC5240 DRAGONSKIN	-F50 CTCS245 DRAGONSKIN
		SDNT	SDHT	SDHT	SDHT	SDHT
		51 029 ...	51 160 ...	50 426 ...	50 421 ...	51 109 ...
0903AEFN	1		02002	548		
0903AESN	1	520			509	57100
P				○		
M				○		
K		●	●	○		
N			●	●		
S			○		●	●
H						
O			○	○		

XDHW

▲ Masterfinish indexable insert (sweeper insert)

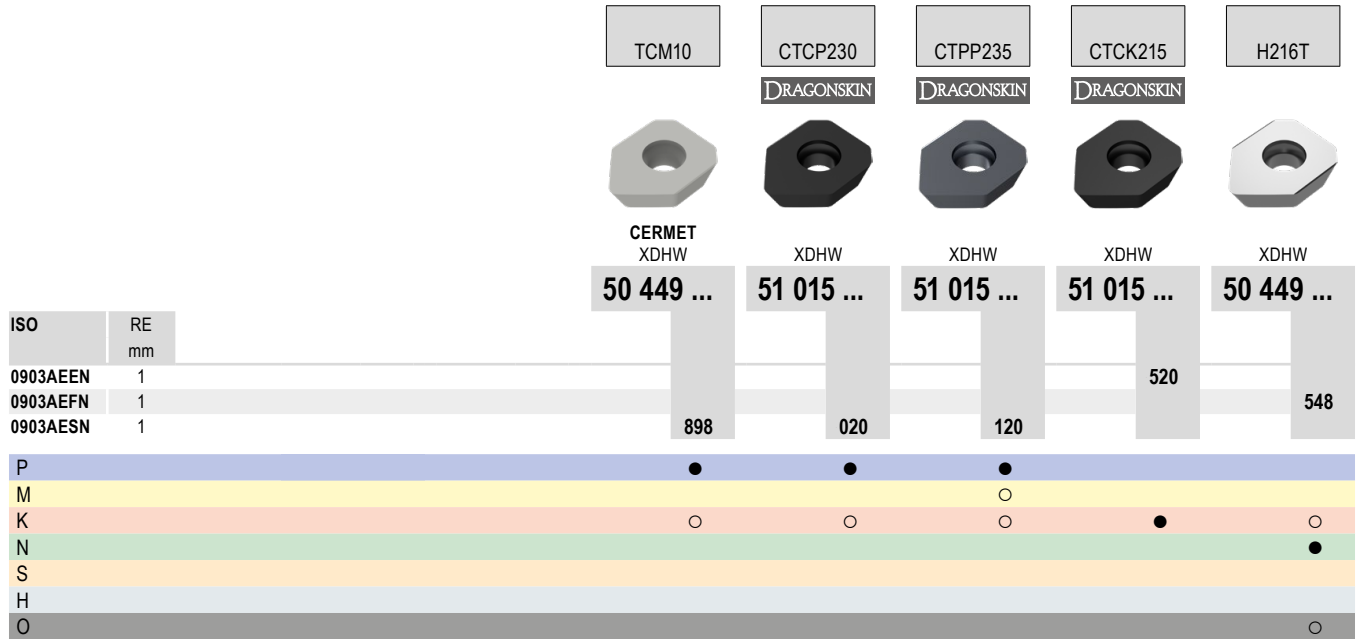

Milling guide

Cutting data standard values	→ 145-148	Machining strategy	→ 156
Technical Information	→ 193-198	Chip groove description and overview	→ 199-201
Grade description and overview	→ 202-208		

MaxiMill – 270-12 Shell mill

- ▲ 50 705 ... Normal pitch for a broad spectrum of use on aluminum alloys, non-ferrous metals, up to soft steel materials
- ▲ 50 706 ... Predominantly fine pitch for highest feed rates, use on steel and cast materials

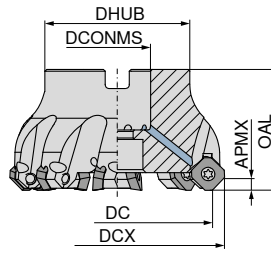
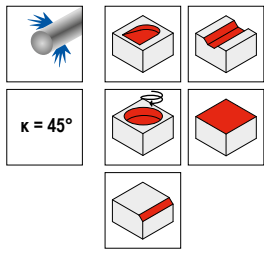

Designation	DC mm	DCX mm	ZNF	APMX mm	DCONMS _{HS} mm	OAL mm	DHUB mm	torque moment Nm	Insert	Series	
										50 705 ...	50 706 ...
A270.40.R.03-12	40	54	3	6	16	40	38	5	SD../XD.. 1204..	040	
A270.40.R.04-12	40	54	4	6	16	40	38	5	SD../XD.. 1204..		040
A270.50.R.04-12	50	64	4	6	22	40	43	5	SD../XD.. 1204..	050	
A270.50.R.05-12	50	64	5	6	22	40	43	5	SD../XD.. 1204..		050
A270.63.R.04-12	63	77	4	6	22	40	48	5	SD../XD.. 1204..	063	
A270.63.R.06-12	63	77	6	6	22	40	48	5	SD../XD.. 1204..		063
A270.80.R.05-12	80	94	5	6	27	50	58	5	SD../XD.. 1204..	080	
A270.80.R.08-12	80	94	8	6	27	50	58	5	SD../XD.. 1204..		080
A270.100.R.06-12	100	114	6	6	32	50	78	5	SD../XD.. 1204..	100	
A270.100.R.10-12	100	114	10	6	32	50	78	5	SD../XD.. 1204..		100
A270.125.R.07-12	125	139	7	6	40	63	88	5	SD../XD.. 1204..	125	
A270.125.R.12-12	125	139	12	6	40	63	88	5	SD../XD.. 1204..		125
A270.160.R.08-12	160	174	8	6	40	63	94	5	SD../XD.. 1204..	160 ¹⁾	

1) With threaded holes M12 on the front face, pitch circle diameter = 66.7 mm / Without Through Coolant

Spare parts	TORX® blade	Clamping key – T	Key D	Power Screw	Molykote	Clamping screw	Torque screwdriver	
	80 950 ...	80 397 ...	80 950 ...	70 950 ...	70 950 ...	70 950 ...	80 950 ...	
DC								
40		037	040	114	151	303	01200	193
50 - 160		037		114		303	01200	193

SDHT / SDHW / SDMT / XDHW

Designation	IC	D1	L	BS	S
	mm	mm	mm	mm	mm
XDHW 1204..	12,7	5,5	7,5	1,74	4,76
SD.. 1204..	12,7	5,5	12,7	1,74	4,76

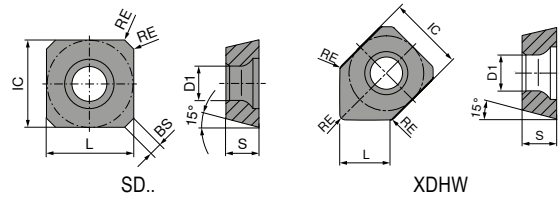

SDHT / SDHW / SDMT

ISO	RE	TCM10	-R TCM10	-29R CTCP230	-R CTCP230	CTCP230
	mm			DRAGONSKIN	DRAGONSKIN	DRAGONSKIN
		CERMET SDHT	CERMET SDHW	SDMT	SDHT	SDHW
		50 426 ...	50 428 ...	51 010 ...	51 006 ...	51 008 ...
1204AESN	0,2	900	899	020	020	020
1204AESN	1,0					
P		●	●	●	●	●
M						
K		○	○	○	○	○
N						
S						
H						
O						

SDMT / SDHT / SDHW

ISO	RE	-29R CTPP235	-R CTPP235	-R CTPP235	-33 CTPM240	-F50 CTPM245	-F50 CTCM245
		DRAGONSKIN	DRAGONSKIN	DRAGONSKIN	DRAGONSKIN	DRAGONSKIN	DRAGONSKIN
		SDMT	SDHT	SDHW	SDHT	SDHT	SDHT
		51 010 ...	51 006 ...	51 008 ...	51 028 ...	51 109 ...	51 109 ...
1204AESN	1	120	120	120	425	475	92501
P		●	●	●	○	●	●
M		○	○	○	●	●	●
K		○	○	○			
N							
S							○
H							
O							

SDMT / SDHW / SDHT

ISO		RE							
		mm							
1204AEEN		1,0		520	520				
1204AEFN		0,2				504	02502		
1204AEFN		1,0						554	
1204AESN		0,2							600

P									
M									
K			•	•	○	•	○	○	○
N					•	•	•	•	•
S							○		
H									
O						○	○	○	○

SDHT

ISO		RE		
		mm		
1204AESN		1		

P				
M				
K				
N				
S			•	•
H				
O				

XDHW

▲ Masterfinish indexable insert (sweeper insert)

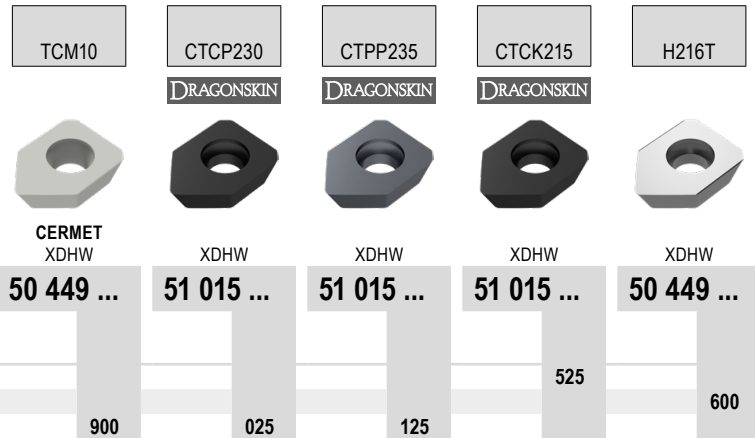

ISO	RE mm
1204AEEN	1
1204AEFN	1
1204AESN	1

P	●	●	●		
M			○		
K	○	○	○	●	○
N					●
S					
H					
O					○

SDHW

Designation	IC mm	D1 mm	L mm	S mm
SDHW 1204..	12,7	5,5	12,7	4,76

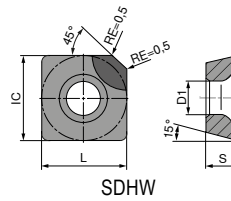

SDHW

	CTDPS30	CTBS10U
DIAMOND SDHW	51 900 ...	51 900 ...
CBN SDHW		
ISO		
1204AEFN-2	100 ¹⁾	
1204AEFN-3	102 ²⁾	
1204AETN-2		300 ¹⁾

P		
M		
K		●
N	●	
S		
H		○
O		

- 1) $a_{p,max} = 2.0$ mm
- 2) $a_{p,max} = 3,5$ mm

Milling guide

Cutting data standard values	→ 145-148	Machining strategy	→ 156
Technical Information	→ 193-198	Chip groove description and overview	→ 199-201
Grade description and overview	→ 202-208		

MaxiMill – 270-19 Shell mill

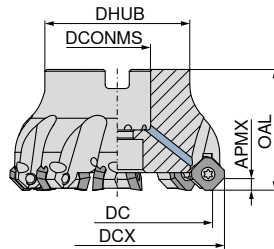
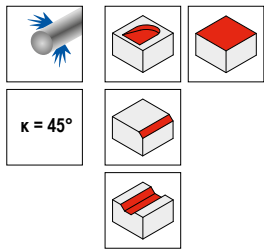

Designation	DC mm	DCX mm	ZNF	APMX mm	DCONMS _{HE} mm	OAL mm	DHUB mm	torque moment Nm	Insert	Left-hand	Right-hand
										50 698 ...	50 698 ...
A270.125.R.07-19	125	146,4	7	10	40	63	88	5	SD.. 1907..		12507
A270.160.R.09-19	160	181,4	9	10	40	63	104	5	SD.. 1907..		16009 ¹⁾
A270.200.R.11-19	200	221,1	11	10	60	63	134	5	SD.. 1907..		20011 ²⁾
A270.250.L.14-19	250	271,4	14	10	60	63	134	5	SD.. 1907..	75014 ²⁾	
A270.250.R.14-19	250	271,4	14	10	60	63	134	5	SD.. 1907..		25014 ²⁾
A270.315.L.17-19	315	336,4	17	10	60	63	226	5	SD.. 1907..	81517 ⁴⁾	
A270.315.R.17-19	315	336,4	17	10	60	63	226	5	SD.. 1907..		31517 ³⁾

- 1) With threaded holes M12 on the front face, pitch circle diameter = 66.7 mm / Without Through Coolant
- 2) With threaded holes M16 on the front face, pitch circle diameter = 101.6 mm / Without Through Coolant
- 3) With 4 threaded holes M16 on the front face, pitch circle diameter = 101.6 mm and with 4 threaded holes M20 on the front face, pitch circle diameter = 177.8 mm / Without Through Coolant
- 4) With 4 threaded holes M16 on the front face, pitch circle diameter = 101.6 mm and with 4 threaded holes M20 on the front face, pitch circle diameter = 177.8 mm

Spare parts	TORX® blade	Key D	Molykote	Clamping screw	Solid Carbide support S	Threaded sleeve	Torque screwdriver
DC	80 950 ...	80 950 ...	70 950 ...	70 950 ...	70 950 ...	70 950 ...	80 950 ...
125 - 315	037	114	303	302	01500	01400	193

SDKT

Designation	IC mm	D1 mm	L mm	BS mm	S mm	AN °
SDKT 1907..	19,15	6	19,15	1,5	7,15	15

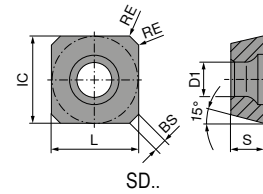

SDKT

ISO	RE mm	-M50 CTCP220	-R50 CTPP225	-R50 CTCP230	-M50 CTPP235	-R50 CTPP235	-R50 CTPM225	-R50 CTCK215
1907AESN	1,6	22001	07000	02100	12000	12300	22200	52000
P		•	•	•	•	•	•	•
M					○	○	•	
K				○	○	○		•
N								
S								
H								
O								

Milling guide

Cutting data standard values	→ 145-148	Technical Information	→ 193-198
Chip groove description and overview	→ 199-201	Grade description and overview	→ 202-208

MaxiMill – HEC 11 Shell mill

▲ not adjustable

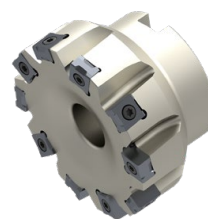
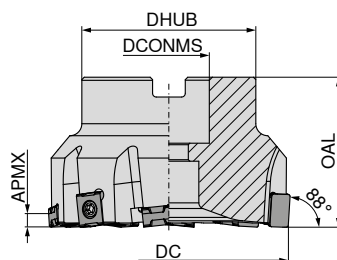
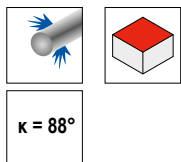

50 725 ...

Designation	DC mm	ZNF	APMX mm	OAL mm	DHUB mm	DCONMS _{H6} mm	RPMX 1/min.	torque moment Nm	Insert
AHEC.50.R.06-11	50	6	6	40	48	22	12700	3,2	LNHX 1106
AHEC.63.R.08-11	63	8	6	40	48	22	10100	3,2	LNHX 1106
AHEC.80.R.10-11	80	10	6	50	58	27	8000	3,2	LNHX 1106
AHEC.100.R.12-11	100	12	6	50	78	32	6400	3,2	LNHX 1106
AHEC.125.R.12-11	125	12	6	63	88	40	5100	3,2	LNHX 1106
AHEC.125.R.16-11	125	16	6	63	88	40	5100	3,2	LNHX 1106
AHEC.160.R.20-11	160	20	6	63	100	40	4000	3,2	LNHX 1106

050
063
080
100
125
12516
160 ¹⁾

1) With threaded holes M12 on the front face, pitch circle diameter = 66.7 mm / Without Through Coolant

MaxiMill – HEC 11 Shell mill

▲ Axially adjustable with same tooth pitch

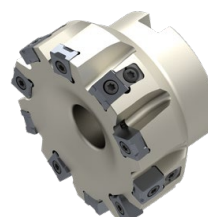
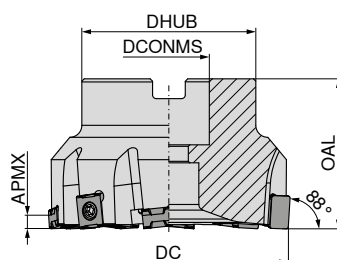
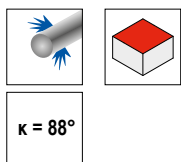

50 733 ...

Designation	DC mm	ZNF	APMX mm	OAL mm	DHUB mm	DCONMS _{H6} mm	RPMX 1/min.	torque moment Nm	Insert
AHEC.50.R.06A03-11	50	6	6	40	48	22	12700	3,2	LNHX 1106
AHEC.63.R.08A04-11	63	8	6	40	48	22	10100	3,2	LNHX 1106
AHEC.80.R.10A05-11	80	10	6	50	58	27	8000	3,2	LNHX 1106
AHEC.100.R.12A06-11	100	12	6	50	78	32	6400	3,2	LNHX 1106
AHEC.125.R.16A08-11	125	16	6	63	88	40	5100	3,2	LNHX 1106
AHEC.160.R.20A10-11	160	20	6	63	100	40	4000	3,2	LNHX 1106

050
063
080
100
125
160 ¹⁾

1) With threaded holes M12 on the front face, pitch circle diameter = 66.7 mm / Without Through Coolant

MaxiMill – HEC 11 Shell mill

▲ with irregular pitch, non adjustable

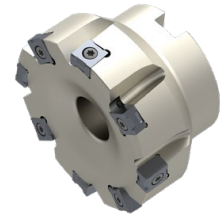
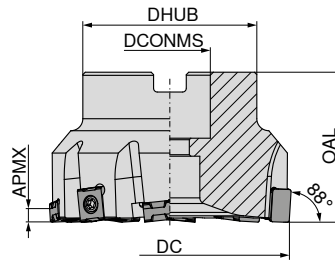
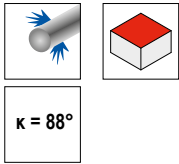

50 733 ...

Designation	DC mm	ZNF	APMX mm	OAL mm	DHUB mm	DCONMS _{H6} mm	RPMX 1/min.	torque moment Nm	Insert	
AHEC.50.R.04B-11	50	4	6	40	48	22	12700	3,2	LNHX 1106	550
AHEC.63.R.06B-11	63	6	6	40	48	22	10100	3,2	LNHX 1106	563
AHEC.80.R.08B-11	80	8	6	50	58	27	8000	3,2	LNHX 1106	580
AHEC.100.R.10B-11	100	10	6	50	78	32	6400	3,2	LNHX 1106	600
AHEC.125.R.12B-11	125	12	6	63	88	40	5100	3,2	LNHX 1106	625
AHEC.160.R.14B-11	160	14	6	63	100	40	4000	3,2	LNHX 1106	660 ¹⁾

1) With threaded holes M12 on the front face, pitch circle diameter = 66.7 mm / Without Through Coolant

Spare parts	TORX® blade	Molykote	Coolant Disc	Clamping screw	Wedge	Torque screwdriver
DC	80 950 ...	70 950 ...	70 950 ...	70 950 ...	70 950 ...	80 950 ...
50 - 63	036	303	852	113		193
80	036	303	853	113	199	193
100	036	303	854	113		193
125	036	303	855	113		193
160	036	303		113		193

LNHX

Designation	IC mm	D1 mm	L mm	S mm
LNHX 1106..	10	4,27	11	6,35

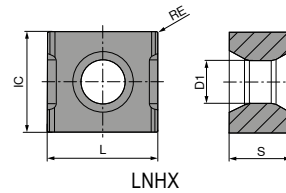

LNHX

Grade	Material	ISO	RE (mm)
CTEP210	DRAGONSKIN	51 046 ...	0,5
CTCK215	DRAGONSKIN	51 046 ...	0,5
-R50 CTCK215	DRAGONSKIN	51 024 ...	0,8
-Q CTCK215	DRAGONSKIN	51 045 ...	1,6

ISO	RE (mm)	51 046 ...	51 046 ...	51 024 ...	51 045 ...
1106PNER	0,5		520	520	520 ¹⁾
1106ZZER	0,5				
1106PNER	0,8	820			
110616EN	1,6		51600		

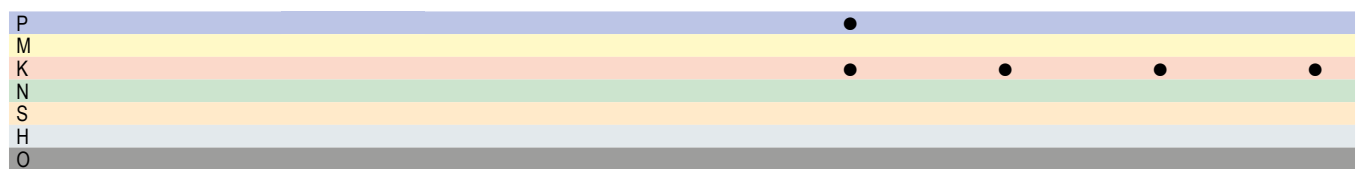

1) -Q = trailing edge insert

LNHX

Grade	Material	ISO	RE (mm)
CTPK220	DRAGONSKIN	51 046 ...	0,5
-R50 CTPK220	DRAGONSKIN	51 024 ...	0,8
CTN3105	CERAMIC	50 500 ...	0,5
CTL3215	CBN	51 046 ...	0,5
-Q CTL3215	CBN	51 045 ...	1,6

ISO	RE (mm)	51 046 ...	51 024 ...	50 500 ...	51 046 ...	51 045 ...
110608EN	0,8		608			
1106PNER	0,5	620	620			
1106PNSR	0,5			904		
1106PNSR					87200	
1106ZZER						87000 ¹⁾

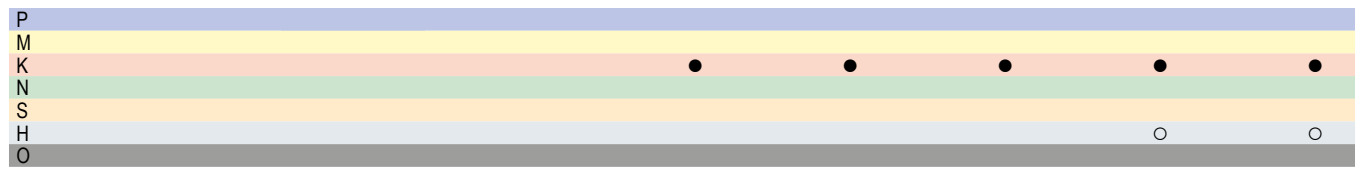

1) -Q = trailing edge insert

Milling guide			
Cutting data standard values	→ 145-148	Assembly instructions	→ 157
Technical Information	→ 193-198	Chip groove description and overview	→ 199-201
Grade description and overview	→ 202-208		

Finishing cutter F 5000 A

- ▲ With μm -adjustable inserts
- ▲ Adjust with screw (56 950 017) and set with Torx 20 key (80 950 114)

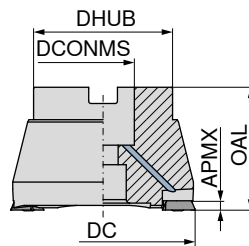
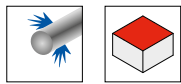

56 511 ...

Designation	DC mm	ZNF	APMX mm	OAL mm	DCONMS mm	DHUB mm	torque moment Nm	Insert	
F5000A.42.2.43.IK	42	2	0,2	43	16	35	3,2	TEHX 16T3..	421
F5000A.52.2.43.IK	52	2	0,2	43	22	48	3,2	TEHX 16T3..	521
F5000A.66.2.53.IK	66	2	0,2	53	27	60	3,2	TEHX 16T3..	661
F5000A.80.2.53.IK	80	2	0,2	53	27	60	3,2	TEHX 16T3..	801
F5000A.100.2.53	100	2	0,2	53	32	70	3,2	TEHX 16T3..	910 ¹⁾

1) Without Through Coolant

Spare parts	TORX® blade	Key-T	Key D	Power Screw	Axial runout adjustment screw	Molykote	Clamping screw	Torque screwdriver
DC	80 950 ...	80 950 ...	80 950 ...	56 950 ...	56 950 ...	70 950 ...	56 950 ...	80 950 ...
42	036	088	114	121	017	303	028	193
52	036	088	113		017	303	028	193
66	036	088	113		017	303	028	193
80	036	088	113		017	303	028	193
100	036	088	113	121	017	303	028	193

Description of article

- ▲ Tightening torque of the indexable insert clamping screw 56 950 028 is 3.2 Nm.
- ▲ This tool produces surfaces with excellent surface quality $R_z \leq 2.5 \mu\text{m}$ with high axial run-out precision.
- ▲ The two precision adjustment screws make adjustment to μm accuracy possible.
- ▲ Additional grinding is therefore avoided, so machining time and costs are reduced.
- ▲ The tool is also well-suited for unstable workpieces and low power machines.



The screws for the adjustment of the axial run-out are mounted on every milling cutter and have to be tightened to a preset value. Otherwise there is the danger that the screws loosen during the machining operation. This can result in damage of the workpiece or tool and also cause danger for the machine operator. Should the screws for fine adjustment not be needed we recommend to remove them from the tool.

Material	v_c m/min	f_z mm	a_p mm
Steel	150–250*)	0,5–2	0,05–0,2
Cast iron	150–250*)	0,5–2	0,05–0,2
Hardened materials ≤ 56 HRC	35–200*)	0,2–1	0,05–0,1

*) Depending on the machining and structural state of the processed workpiece.

TEHX

Designation	L mm	S mm	D1 mm
TEHX 16T3..	14,32	4,00	3,9

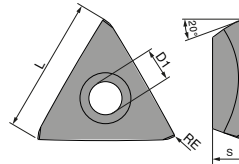

TEHX

WTN1205



TEHX

56 327 ...

ISO	RE mm
16T3ZF	0,2

151

P	●
M	●
K	●
N	●
S	●
H	●
O	●

Milling guide

Cutting data standard values	→ 145-148	Technical Information	→ 193-198
Chip groove description and overview	→ 199-201	Grade description and overview	→ 202-208

MaxiMill – 491-09 Screw in cutter

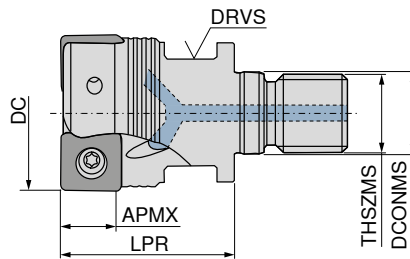
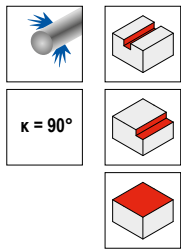

50 773 ...

Designation	DC mm	ZNF	APMX mm	LPR mm	THSZMS	DCONMS mm	DRVS mm	torque moment Nm	Insert
G491.25.R.03-09	25	3	6	35	M12	12,5	17	2	SNHU 09T3
G491.32.R.03-09	32	3	6	35	M16	17,0	24	2	SNHU 09T3
G491.32.R.04-09	32	4	6	35	M16	17,0	24	2	SNHU 09T3

125
132
232

MaxiMill – 491-09 End milling cutter

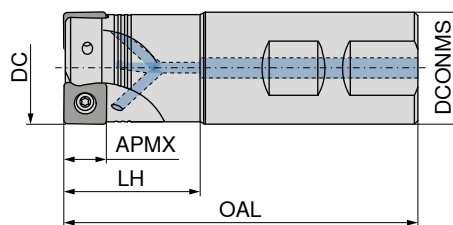
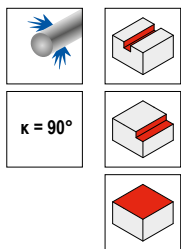

50 774 ... 50 774 ...

Designation	DC mm	ZNF	APMX mm	OAL mm	LH mm	DCONMS _{h6} mm	RPMX 1/min.	torque moment Nm	Insert
C491.25.R.03-09-B-32	25	3	6	89	32	25	23500	2	SNHU 09T3
C491.25.R.03-09-A-50-225	25	3	6	225	50	25	23500	2	SNHU 09T3
C491.32.R.03-09-B-40	32	3	6	101	40	32	19600	2	SNHU 09T3
C491.32.R.04-09-B-40	32	4	6	101	40	32	19600	2	SNHU 09T3
C491.32.R.03-09-A-63-250	32	3	6	250	63	32	19600	2	SNHU 09T3
C491.32.R.04-09-A-63-250	32	4	6	250	63	32	19600	2	SNHU 09T3

325
632
432
532
332





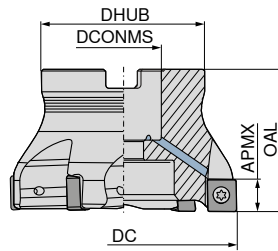
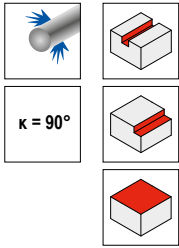

Spare parts
DC
25 - 32

TORX® blade	Key D	Molykote	Clamping screw	Torque screwdriver
80 950 ...	80 950 ...	70 950 ...	70 950 ...	80 950 ...
053	119	303	710	193

MaxiMill – 491-09 Shell mill



Designation	DC mm	ZNF	APMX mm	OAL mm	DHUB mm	DCONMS _{H6} mm	RPMX 1/min.	torque moment Nm	Insert	50 776 ...		50 775 ...	
A491.40.R.03-09	40	3	6	40	38	16	16800	2	SNHU 09T3				240
A491.40.R.05-09	40	5	6	40	38	16	16800	2	SNHU 09T3	240			
A491.50.R.04-09	50	4	6	40	43	22	14600	2	SNHU 09T3				250
A491.50.R.06-09	50	6	6	40	43	22	14600	2	SNHU 09T3	250			
A491.63.R.05-09	63	5	6	40	48	22	12700	2	SNHU 09T3				263
A491.63.R.08-09	63	8	6	40	48	22	12700	2	SNHU 09T3	263			
A491.80.R.06-09	80	6	6	50	58	27	11100	2	SNHU 09T3				280
A491.80.R.10-09	80	10	6	50	58	27	11100	2	SNHU 09T3	280			
A491.100.R.07-09	100	7	6	50	78	32	9800	2	SNHU 09T3				300
A491.100.R.12-09	100	12	6	50	78	32	9800	2	SNHU 09T3	300			
A491.125.R.08-09	125	8	6	63	88	40	8700	2	SNHU 09T3				325
A491.125.R.15-09	125	15	6	63	88	40	8700	2	SNHU 09T3	325			

Spare parts	 TORX® blade  Clamping key – T  Key D  Power Screw  Molykote  Clamping screw  Torque screwdriver							
	80 950 ...	80 397 ...	80 950 ...	70 950 ...	70 950 ...	70 950 ...	80 950 ...	
DC								
40		053	040	119	151	303	710	193
50 - 125		053		119		303	710	193

SNHU

Designation	IC mm	L mm	S mm	D1 mm
SNHU 09T3..	9,15	9,15	3,70	3,85

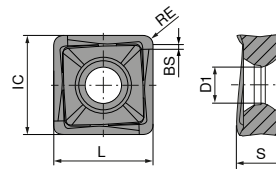

SNHU

ISO	RE mm	-M50 CTCP230	-M50 CTPP235	-F50 CTPM240	-M50 CTPM240	-F40 CTPM245	-F40 CTCM245
		DRAGONSKIN	DRAGONSKIN	DRAGONSKIN	DRAGONSKIN	DRAGONSKIN	DRAGONSKIN
		SNHU	SNHU	SNHU	SNHU	SNHU	SNHU
		51 120 ...	51 120 ...	51 119 ...	51 120 ...	51 126 ...	51 126 ...
09T308ER	0,8	008	108	408	408	45800	90801
09T308SR	0,8	01200	11200	41200	41200		
09T312SR	1,2	01600	11600	41600	41600		
09T316SR	1,6						
P		●	●	○	○	●	●
M			○	●	●	●	●
K		○	○				
N							
S							○
H							
O							

SNHU

ISO	RE mm	-R50 CTCK215	-R50 CTPK220	NEW -F10 CTPX715	-F10 CTWN215	-F40 CTC5240	-F40 CTCS245
		DRAGONSKIN	DRAGONSKIN	DRAGONSKIN	DRAGONSKIN	DRAGONSKIN	DRAGONSKIN
		SNHU	SNHU	SNHU	SNHU	SNHU	SNHU
		51 121 ...	51 121 ...	51 118 ...	51 118 ...	51 126 ...	51 126 ...
09T308ER	0,8			00802	358	15800	55800
09T308FR	0,8						
09T308SR	0,8	508	60800				
09T312FR	1,2						
09T312SR	1,2	51200					
09T316FR	1,6						
09T316SR	1,6	51600					
P				○			
M				○			
K		●	●	●	○		
N				●	●		
S				○		●	●
H							
O				○	○		

Milling guide

Cutting data standard values	→ 145-148	Starting Parameter	→ 159
Technical Information	→ 193-198	Chip groove description and overview	→ 199-201
Grade description and overview	→ 202-208		

MaxiMill – 491-12 Screw in cutter

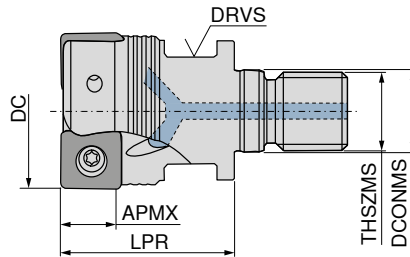
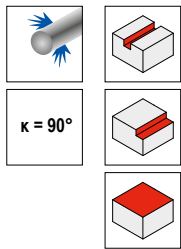

50 773 ...

Designation	DC mm	ZNF	APMX mm	LPR mm	THSZMS M16	DCONMS mm	DRVS mm	torque moment Nm	Insert
G491.32.R.02-12	32	2	8	35	M16	17	24	3,2	SNHU 1204

032

MaxiMill – 491-12 End milling cutter

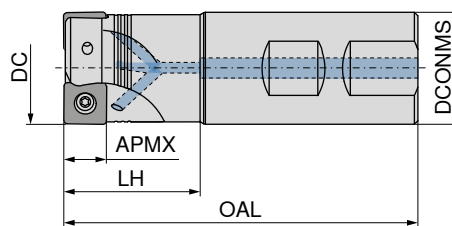
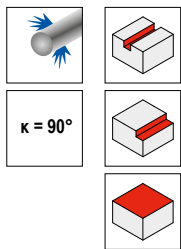

50 774 ...





50 774 ...

Designation	DC mm	ZNF	APMX mm	OAL mm	LH mm	DCONMS _{h6} mm	RPMX 1/min.	torque moment Nm	Insert
C491.32.R.02-12-B-40	32	2	8	102	40	32	13600	3,2	SNHU 1204
C491.32.R.02-12-A-63-250	32	2	8	250	63	32	10200	3,2	SNHU 1204

232

032

Spare parts
DC
32

 TORX® blade	 Key D	 Molykote	 Clamping screw	 Torque screwdriver
80 950 ...	80 950 ...	70 950 ...	70 950 ...	80 950 ...
054	128	303	859	193

MaxiMill – 491-12 Shell mill

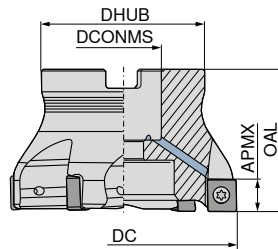
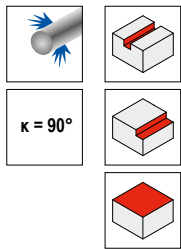

Designation	DC mm	ZNF	APMX mm	OAL mm	DHUB mm	DCONMS _{H6} mm	RPMX 1/min.	torque moment Nm	Insert	50 776 ...		50 775 ...	
A491.40.R.03-12	40	3	8	40	38	16	11500	3,2	SNHU 1204				040
A491.40.R.04-12	40	4	8	40	38	16	11500	3,2	SNHU 1204	040			
A491.50.R.04-12	50	4	8	40	43	22	9800	3,2	SNHU 1204				050
A491.50.R.05-12	50	5	8	40	43	22	9800	3,2	SNHU 1204	050			
A491.63.R.05-12	63	5	8	40	48	22	8500	3,2	SNHU 1204				063
A491.63.R.06-12	63	6	8	40	48	22	8500	3,2	SNHU 1204	063			
A491.80.R.06-12	80	6	8	50	58	27	7400	3,2	SNHU 1204				080
A491.80.R.08-12	80	8	8	50	58	27	7400	3,2	SNHU 1204	080			
A491.100.R.07-12	100	7	8	50	78	32	6500	3,2	SNHU 1204				100
A491.100.R.10-12	100	10	8	50	78	32	6500	3,2	SNHU 1204	100			
A491.125.R.08-12	125	8	8	63	88	40	5700	3,2	SNHU 1204				125
A491.125.R.12-12	125	12	8	63	88	40	5700	3,2	SNHU 1204	125			
A491.160.R.09-12	160	9	8	63	98	40	5000	3,2	SNHU 1204				160 ¹⁾
A491.160.R.14-12	160	14	8	63	98	40	5000	3,2	SNHU 1204	160 ¹⁾			

1) With threaded holes M12 on the front face, pitch circle diameter = 66.7 mm / Without Through Coolant

Spare parts DC	TORX® blade	Clamping key – T	Key D	Power Screw	Molykote	Clamping screw	Torque screwdriver
	80 950 ...	80 397 ...	80 950 ...	70 950 ...	70 950 ...	70 950 ...	80 950 ...
40	054	040	128	151	303	859	193
50 - 160	054		128		303	859	193

SNHU

Designation	IC mm	L mm	S mm	D1 mm
SNHU 1204..	12,2	12,2	5,00	4,4

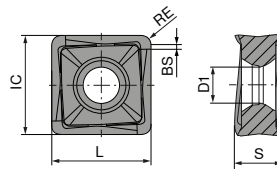

SNHU

ISO	RE mm	-M50 CTCP230 DRAGONSKIN SNHU 51 100 ...	-M50 CTPP235 DRAGONSKIN SNHU 51 100 ...	-F50 CTPM240 DRAGONSKIN SNHU 51 102 ...	-M50 CTPM240 DRAGONSKIN SNHU 51 100 ...	-F40 CTPM245 DRAGONSKIN SNHU 51 128 ...	-F40 CTCM245 DRAGONSKIN SNHU 51 128 ...
120408ER	0,8						
120408SR	0,8	008	108	408	408	45800	90801
120412SR	1,2		112	412			
120416SR	1,6		116	416			
120420SR	2,0		120	420			
P		●	●	○	○	●	●
M			○	●	●	●	●
K		○	○				
N							
S							○
H							
O							

SNHU

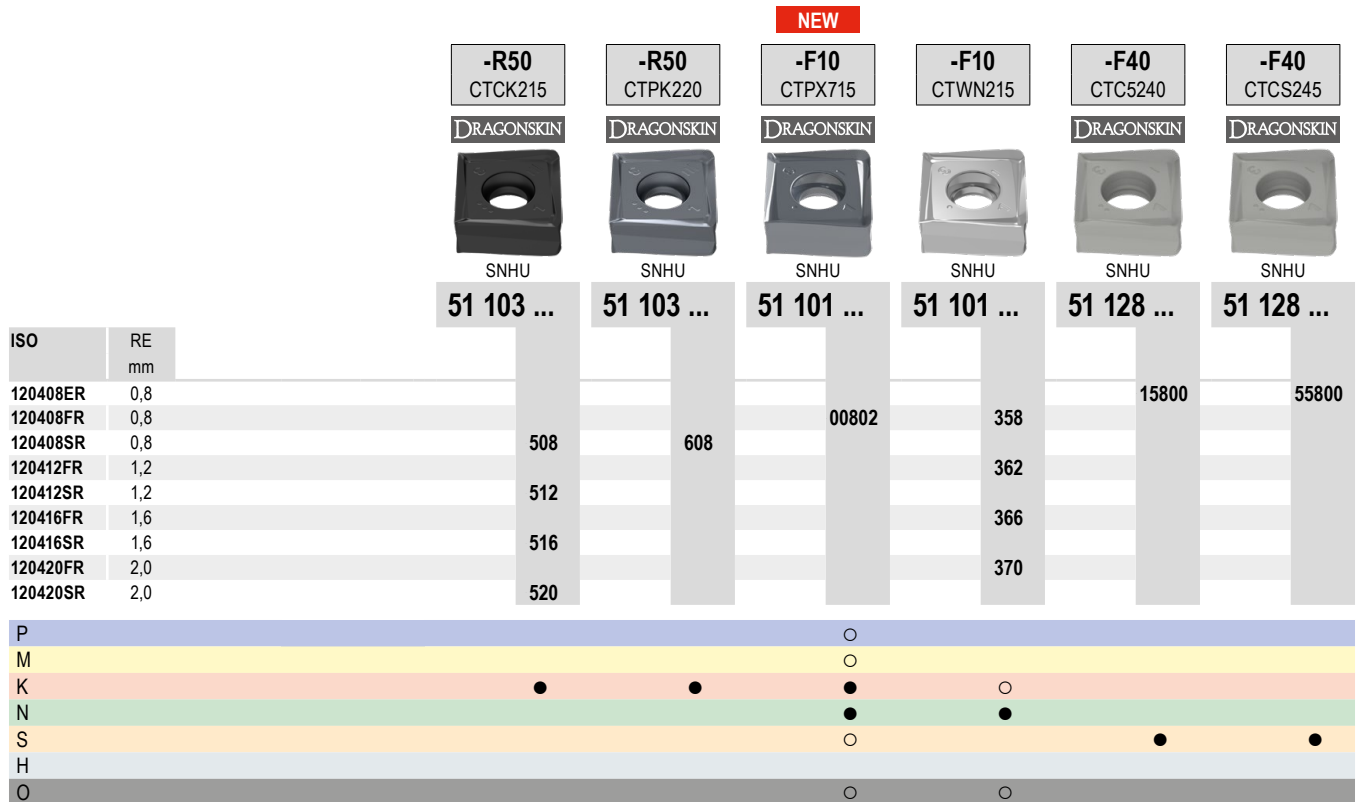

Milling guide

Cutting data standard values	→ 145-148	Starting Parameter	→ 159
Technical Information	→ 193-198	Chip groove description and overview	→ 199-201
Grade description and overview	→ 202-208		

MaxiMill – 211-07 Screw in cutter

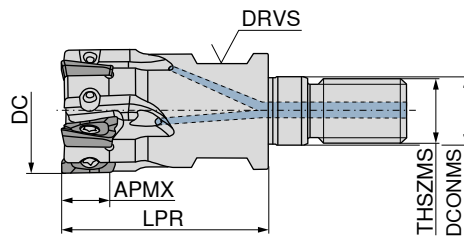
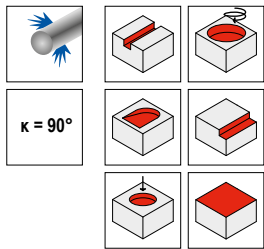

50 751 ...

Designation	DC mm	ZNF	APMX mm	LPR mm	DCONMS mm	THSZMS mm	DRVS mm	RPMX 1/min.	torque moment Nm	Insert	
G211.16.R.04-07	16	4	6	27	8,5	M8	10	50400	1	XD.T 0703	016
G211.20.R.05-07	20	5	6	33	10,5	M10	15	44280	1	XD.T 0703	020
G211.25.R.06-07	25	6	6	35	12,5	M12	17	39480	1	XD.T 0703	025
G211.32.R.08-07	32	8	6	35	17,0	M16	24	36240	1	XD.T 0703	032

MaxiMill – 211-07 End milling cutter

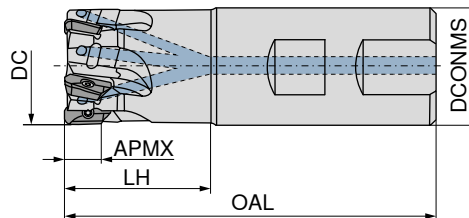
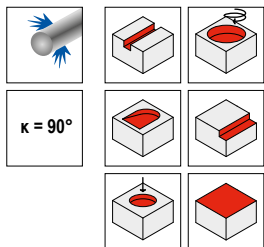

Designation	DC mm	ZNF	APMX mm	OAL mm	LH mm	DCONMS mm	RPMX 1/min.	torque moment Nm	Insert	50 752 ...	50 752 ...
C211.10.R.01-07-A-20	10	1	6	61,0	20	10	72000	1	XD.T 0703	010	
C211.12.R.02-07-A-20	12	2	6	66,5	20	12	66600	1	XD.T 0703	012	
C211.16.R.04-07-A/B-25	16	4	6	74,5	25	16	50400	1	XD.T 0703	016	216
C211.16.R.03-07-A-32-165	16	3	6	165,0	32	16	17760	1	XD.T 0703	016	
C211.20.R.05-07-A/B-25	20	5	6	77,0	25	20	44280	1	XD.T 0703	020	220
C211.20.R.04-07-A-40-200	20	4	6	200,0	40	20	12600	1	XD.T 0703	020	
C211.25.R.06-07-A/B20-32	25	6	6	84,0	32	20	39840	1	XD.T 0703	025	225
C211.25.R.05-07-A20-50-225	25	5	6	225,0	50	20	11280	1	XD.T 0703	025	
C211.32.R.08-07-A/B25-40	32	8	6	98,0	40	25	36240	1	XD.T 0703	032	232

MaxiMill – 211-07 Shell mill

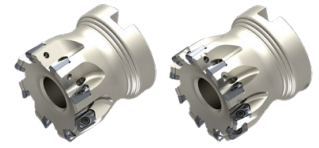
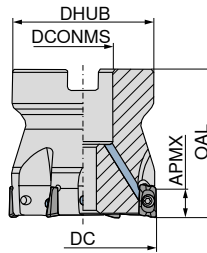
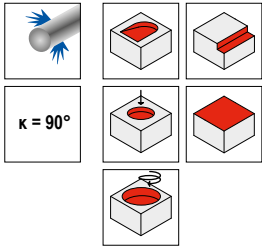

Designation	DC mm	ZNF	APMX mm	OAL mm	DCONMS _{H6} mm	DHUB mm	RPMX 1/min.	torque moment Nm	Insert	50 753 ...		50 754 ...	
A211.32.R.06-07	32	6	6	40	16	38	36240	1	XD.T 0703	032			
A211.32.R.08-07	32	8	6	40	16	38	36240	1	XD.T 0703				032
A211.40.R.08-07	40	8	6	40	16	38	33240	1	XD.T 0703	040			
A211.40.R.10-07	40	10	6	40	16	38	33240	1	XD.T 0703				040
A211.50.R.10-07	50	10	6	40	22	43	30480	1	XD.T 0703	050			
A211.50.R.12-07	50	12	6	40	22	43	30480	1	XD.T 0703				050

Spare parts DC	TORX® blade	Clamping key – T	Key D	Power Screw	Molykote	Clamping screw	Torque screwdriver
	80 950 ...	80 397 ...	80 950 ...	70 950 ...	70 950 ...	70 950 ...	80 950 ...
10 - 32	051		124		303	137	191
32	051	040	124	151	303	137	191
40 - 50	051		124		303	137	191

XDKT

Designation	IC mm	D1 mm	L mm	BS mm	S mm
XDKT 0703..	4,9	2,5	7,8	1,2	3,18

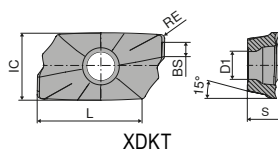

XDKT

Grade	CTCP230	CTCP230	CTPP235	CTPP235
DRAGONSKIN	DRAGONSKIN	DRAGONSKIN	DRAGONSKIN	DRAGONSKIN
F	M	F	M	
XDKT	XDKT	XDKT	XDKT	
51 033 ...	51 036 ...	51 033 ...	51 036 ...	
004	004	104	104	
008	008	108	108	

ISO	RE mm
070304SR	0,4
070308SR	0,8

P	●	●	●	●
M			○	○
K	○	○	○	○
N				
S				
H				
O				

XDKT

Grade	CTPM240	CTPM240	CTPM245	CTCM245	CTWN215	CTC5240	CTCS245
DRAGONSKIN	DRAGONSKIN	DRAGONSKIN	DRAGONSKIN	DRAGONSKIN		DRAGONSKIN	DRAGONSKIN
F	M	F	F	F	F	F	F
XDKT	XDKT	XDKT	XDKT	XDKT	XDKT	XDKT	XDKT
51 033 ...	51 036 ...	51 112 ...	51 112 ...	50 507 ...	50 498 ...	51 112 ...	
404	404	454	90401	504	544		
408	408	458	90801	508	548	558	

ISO	RE mm
070304ER	0,4
070304FR	0,4
070304SR	0,4
070308ER	0,8
070308FR	0,8
070308SR	0,8

P	○	○	●	●			
M	●	●	●	●			
K					○		
N					●		
S				○		●	●
H							
O					○		

Milling guide

Cutting data standard values	→ 145-148	Machining strategy	→ 160
Starting Parameter	→ 160	Technical Information	→ 193-198
Chip groove description and overview	→ 199-201	Grade description and overview	→ 202-208

MaxiMill – 211-11 Screw in cutter

▲ Insert radius >1,6 mm: Modify cutter body

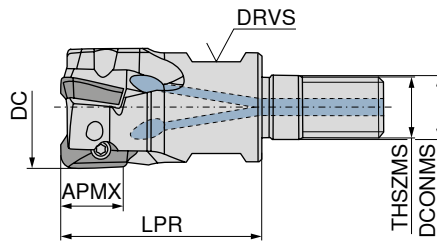
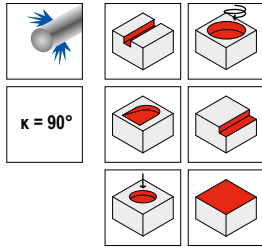

50 736 ...

Designation	DC mm	ZNF	APMX mm	LPR mm	DCONMS mm	THSZMS	DRVS mm	RPMX 1/min.	torque moment Nm	Insert	
G211.16.R.02-11	16	2	10	27	8,5	M8	10	42000	1,6	XD.T 11T3	016
G211.20.R.03-11	20	3	10	33	10,5	M10	15	36900	1,6	XD.T 11T3	020
G211.25.R.03-11	25	3	10	35	12,5	M12	17	33200	1,6	XD.T 11T3	12500
G211.25.R.04-11	25	4	10	35	12,5	M12	17	33200	1,6	XD.T 11T3	025
G211.32.R.04-11	32	4	10	35	17,0	M16	24	30200	1,6	XD.T 11T3	13200
G211.32.R.05-11	32	5	10	35	17,0	M16	24	30200	1,6	XD.T 11T3	032
G211.40.R.06-11	40	6	10	35	17,0	M16	27	27700	1,6	XD.T 11T3	040

MaxiMill – 211-11 End milling cutter

▲ Insert radius >1,6 mm: Modify cutter body

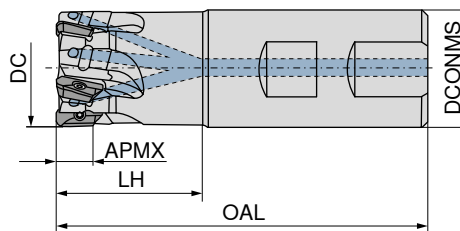
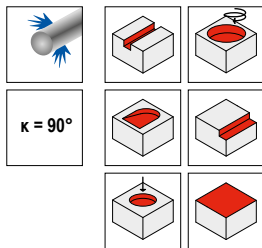

Designation	DC mm	ZNF	APMX mm	OAL mm	LH mm	DCONMS _{h6} mm	RPMX 1/min.	torque moment Nm	Insert	50 737 ...	50 737 ...
C211.12.R.01-11-B-20	12	1	10	75	20	16	55000	1,6	XD.T 11T3		012
C211.16.R.02-11-A/B-25	16	2	10	75	25	16	42000	1,6	XD.T 11T3	116	016
C211.16.R.02-11-A15-32-165	16	2	10	165	32	15	14800	1,6	XD.T 11T3	316	
C211.16.R.02-11-A-32-165	16	2	10	165	32	16	14800	1,6	XD.T 11T3	216	
C211.20.R.03-11-A-25	20	3	10	77	25	20	36900	1,6	XD.T 11T3	120	
C211.20.R.03-11-B-25	20	3	10	77	25	20	36900	1,6	XD.T 11T3		020
C211.20.R.02-11-B-25	20	2	10	77	25	20	36900	1,6	XD.T 11T3		02002
C211.20.R.02-11-A-25	20	2	10	77	25	20	36900	1,6	XD.T 11T3	12002	
C211.20.R.03-11-A-32-165	20	3	10	165	32	20	15800	1,6	XD.T 11T3	320	
C211.20.R.02-11-A-40-200	20	2	10	200	40	20	10500	1,6	XD.T 11T3	420	
C211.20.R.02-11-A19-40-200	20	2	10	200	40	19	10500	1,6	XD.T 11T3	620	
C211.25.R.03-11-A/B-32	25	3	10	90	32	25	33200	1,6	XD.T 11T3	625	725
C211.25.R.04-11-A/B-32	25	4	10	90	32	25	33200	1,6	XD.T 11T3	125	025
C211.25.R.04-11-A-40-165	25	4	10	165	40	25	19900	1,6	XD.T 11T3	325	
C211.25.R.03-11-A-50-225	25	3	10	225	50	25	9400	1,6	XD.T 11T3	425	
C211.25.R.03-11-A24-50-225	25	3	10	225	50	24	9400	1,6	XD.T 11T3	825	
C211.25.R.02-11-A-50-225	25	2	10	225	50	25	9400	1,6	XD.T 11T3	02502	
C211.32.R.04-11-A-40	32	4	10	102	40	32	30200	1,6	XD.T 11T3	13204	
C211.32.R.05-11-A/B-40	32	5	10	102	40	32	30200	1,6	XD.T 11T3	132	032
C211.32.R.04-11-B-25	32	4	10	102	40	32	30200	1,6	XD.T 11T3		83200
C211.32.R.05-11-B25-40	32	5	10	102	40	25	30200	1,6	XD.T 11T3		73200
C211.32.R.04-11-A25-40	32	4	10	102	40	25	30200	1,6	XD.T 11T3	53204	
C211.32.R.05-11-A-50-165	32	5	10	165	50	32	20900	1,6	XD.T 11T3	332	
C211.32.R.04-11-A-64-250	32	4	10	250	64	32	8500	1,6	XD.T 11T3	432	
C211.40.R.06-11-B32-50	40	6	10	110	50	32	27700	1,6	XD.T 11T3		04000
C211.40.R.06-11-B-50	40	6	10	122	50	40	27700	1,6	XD.T 11T3		14000

15

MaxiMill – 211-11 Shell mill

▲ Insert radius >1,6 mm: Modify cutter body

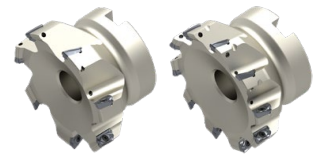
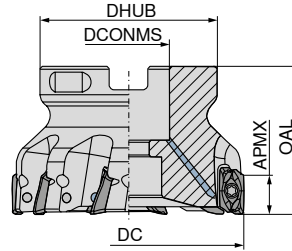
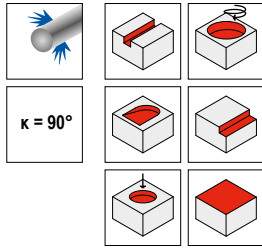

Designation	DC mm	ZNF	APMX mm	OAL mm	DCONMS _{H6} mm	DHUB mm	RPMX 1/min.	torque moment Nm	Insert	50 738 ...		50 739 ...	
A211.40.R.04-11	40	4	10	40	16	38	27700	1,6	XD.T 11T3	040			
A211.40.R.06-11	40	6	10	40	16	38	27700	1,6	XD.T 11T3				040
A211.50.R.05-11	50	5	10	40	22	43	25400	1,6	XD.T 11T3	050			
A211.50.R.08-11	50	8	10	40	22	43	25400	1,6	XD.T 11T3				050
A211.63.R.06-11	63	6	10	40	22	48	23300	1,6	XD.T 11T3	063			
A211.63.R.10-11	63	10	10	40	22	48	23300	1,6	XD.T 11T3				063
A211.80.R.07-11	80	7	10	50	27	58	21300	1,6	XD.T 11T3	080			
A211.80.R.10-11	80	10	10	50	27	58	21300	1,6	XD.T 11T3				180
A211.80.R.12-11	80	12	10	50	27	58	21300	1,6	XD.T 11T3				08012
A211.100.R.08-11	100	8	10	50	32	78	19600	1,6	XD.T 11T3	10000			
A211.100.R.14-11	100	14	10	50	32	78	19600	1,6	XD.T 11T3				10014
A211.125.R.10-11	125	10	10	63	40	88	17900	1,6	XD.T 11T3	12500			

Spare parts DC	TORX® blade	Clamping key – T	Key D	Power Screw	Molykote	Clamping screw	Torque screwdriver
	80 950 ...	80 397 ...	80 950 ...	70 950 ...	70 950 ...	70 950 ...	80 950 ...
12	043		125		303	92000	191
16 - 32	043		125		303	128	191
40	043	040	125		303	131	191
50	043	050	125	151	303	131	191
63 - 125	043		125		303	131	191

MaxiMill – 211-11KN shell end mill shank

▲ ZEFP = Number of inserts
▲ ZNP = Number of teeth

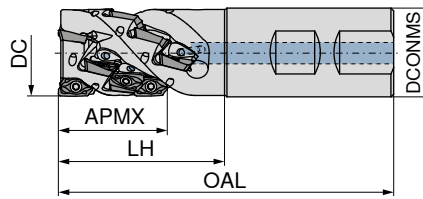
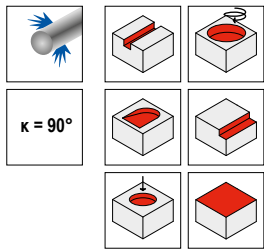

50 784 ...

Designation	DC mm	ZNF	APMX mm	OAL mm	LH mm	DCONMS mm	ZEFP	ZNP	torque moment Nm	Insert	
C211.25.R.02KN3-11-B-40	25	2	28	97	40	25	6	3	1,6	XD.T 11T3	02523
C211.25.R.02KN4-11-B-50	25	2	37	107	50	25	8	4	1,6	XD.T 11T3	02524
C211.25.R.02KN5-11-B-60	25	2	46	117	60	25	10	5	1,6	XD.T 11T3	02525
C211.32.R.02KN4-11-B-50	32	2	37	111	50	32	8	4	1,6	XD.T 11T3	03224
C211.32.R.03KN5-11-B-60	32	3	46	121	60	32	15	5	1,6	XD.T 11T3	03235
C211.40.R.03KN4-11-B32-50	40	3	37	111	50	32	12	4	1,6	XD.T 11T3	04034
C211.40.R.04KN5-11-B32-60	40	4	46	121	60	32	20	5	1,6	XD.T 11T3	04045





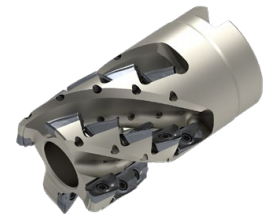
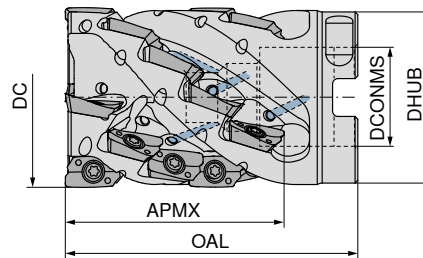
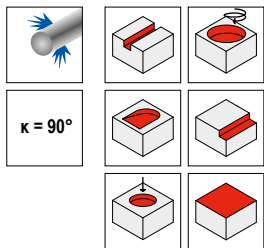

MaxiMill – 211-11KN shell end face mill

▲ ZEFP = Number of inserts
▲ ZNP = Number of teeth



50 794 ...

Designation	DC mm	ZNF	APMX mm	ZEFP	ZNP	OAL mm	DCONMS _{H6} mm	DHUB mm	torque moment Nm	Insert	
A211.40.R.03KN4-11	40	3	37	12	4	65	22	38	1,6	XD.T 11T3	04034
A211.40.R.04KN4-11	40	4	37	16	4	65	22	38	1,6	XD.T 11T3	04044
A211.40.R.04KN5-11	40	4	46	20	5	74	22	38	1,6	XD.T 11T3	04045
A211.50.R.04KN5-11	50	4	46	20	5	75	27	48	1,6	XD.T 11T3	05045
A211.50.R.05KN5-11	50	5	46	25	5	75	27	48	1,6	XD.T 11T3	05055
A211.50.R.05KN6-11	50	5	55	30	6	85	27	48	1,6	XD.T 11T3	05056

	 Cylindrical screw	 TORX® blade	 Key D	 Molykote	 Clamping screw	 Socket head screw	 Torque screwdriver
Spare parts							
Designation							
A211.40.R.03KN4-11			043	125	303	20400	191
A211.40.R.04KN4-11			043	125	303	20400	191
A211.40.R.04KN5-11			043	125	303	20400	191
A211.50.R.04KN5-11	002		043	125	303	20400	191
A211.50.R.05KN5-11	002		043	125	303	20400	191
A211.50.R.05KN6-11	002		043	125	303	20400	191
C211.25.R.02KN3-11-B-40			043	125	303	20700	191
C211.25.R.02KN4-11-B-50			043	125	303	20700	191
C211.25.R.02KN5-11-B-60			043	125	303	20700	191
C211.32.R.02KN4-11-B-50			043	125	303	20700	191
C211.32.R.03KN5-11-B-60			043	125	303	20700	191
C211.40.R.03KN4-11-B32-50			043	125	303	20400	191
C211.40.R.04KN5-11-B32-60			043	125	303	20400	191

XDKT / XDHT

Designation	IC	D1	L	BS	S
	mm	mm	mm	mm	mm
XD.T 11T302..	6,8	2,8	10,6	2	3,80
XD.T 11T304..	6,8	2,8	10,6	1,8	3,80
XD.T 11T308..	6,8	2,8	10,6	1,4	3,80
XD.T 11T312..	6,8	2,8	10,6	1,4	3,80
XD.T 11T316..	6,8	2,8	10,6	1,4	3,80
XD.T 11T320..	6,8	2,8	10,6	1,4	3,80
XD.T 11T325..	6,8	2,8	10,6	1,4	3,80
XD.T 11T332..	6,8	2,8	10,6	0,8	3,80
XD.T 11T340..	6,8	2,8	10,6	-	3,80
XDHT 11T350..	6,8	2,8	10,6	-	3,80
XDKT 11T332..	6,8	2,8	10,6	1,4	3,80

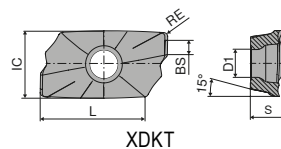

XDKT

-F50	-M50	-F50	-M50
CTCP220	CTCP220	CTPP225	CTPP225
DRAGONSKIN	DRAGONSKIN	DRAGONSKIN	DRAGONSKIN
F	M	F	M
XDKT	XDKT	XDKT	XDKT
51 034 ...	51 037 ...	51 034 ...	51 037 ...
258	258	058	058

ISO	RE
	mm
11T308SR	0,8

P	●	●	●	●
M				
K				
N				
S				
H				
O				

XDKT

-F50	-M50	-R50	-F50	-M50	-R50
CTCP230	CTCP230	CTCP230	CTPP235	CTPP235	CTPP235
DRAGONSKIN	DRAGONSKIN	DRAGONSKIN	DRAGONSKIN	DRAGONSKIN	DRAGONSKIN
F	M	R	F	M	R
XDKT	XDKT	XDKT	XDKT	XDKT	XDKT
51 034 ...	51 037 ...	51 039 ...	51 034 ...	51 037 ...	51 039 ...
004	004	004	104	104	104
008	008	008	108	108	108
	012			112	
020 ¹⁾	020 ¹⁾	020 ¹⁾	120 ¹⁾	120 ¹⁾	120 ¹⁾
025 ¹⁾	025 ¹⁾	025 ¹⁾	125 ¹⁾	125 ¹⁾	125 ¹⁾

ISO	RE
	mm
11T304SR	0,4
11T308SR	0,8
11T312SR	1,2
11T320SR	2,0
11T325SR	2,5

P	●	●	●	●	●
M					
K	○	○	○	○	○
N					
S					
H					
O					

1) Insert radius >1.6 mm: Modify cutter body

XDKT

ISO	RE mm	-F50 CTPM225 DRAGONSKIN F XDKT 51 034 ... 208	-M50 CTPM225 DRAGONSKIN M XDKT 51 037 ... 208	-R50 CTPM225 DRAGONSKIN R XDKT 51 039 ... 208	-F50 CTCM235 DRAGONSKIN F XDKT 51 034 ... 308	-M50 CTCM235 DRAGONSKIN M XDKT 51 037 ... 308	-R50 CTCM235 DRAGONSKIN R XDKT 51 039 ... 308
11T308SR	0,8						
P		•	•	•	•	•	•
M		•	•	•	•	•	•
K							
N							
S							
H							
O							

XDKT

ISO	RE mm	-F50 CTPM240 DRAGONSKIN F XDKT 51 034 ...	-M50 CTPM240 DRAGONSKIN M XDKT 51 037 ...	-R50 CTPM240 DRAGONSKIN R XDKT 51 039 ...	-F40 CTPM245 DRAGONSKIN F XDKT 51 113 ...	-F50 CTPM245 DRAGONSKIN F XDKT 51 034 ...	-F40 CTCM245 DRAGONSKIN F XDKT 51 113 ...	-F50 CTCM245 DRAGONSKIN F XDKT 51 034 ...
11T304ER	0,4				454		90401	
11T304SR	0,4		404		458		90801	
11T308ER	0,8				462		91201	
11T308SR	0,8	408	408	408	466	458	91601	90801
11T312ER	1,2	412	412	412	470 ¹⁾		92001 ¹⁾	
11T312SR	1,2				475 ¹⁾		92501 ¹⁾	
11T316ER	1,6				482 ¹⁾		93201 ¹⁾	
11T320ER	2,0				490 ¹⁾		94001 ¹⁾	
11T320SR	2,0	420 ¹⁾	420 ¹⁾	420 ¹⁾				
11T325ER	2,5							
11T332ER	3,2							
11T332SR	3,2	432 ¹⁾	432 ¹⁾	432 ¹⁾				
11T340ER	4,0							
P		○	○	○	•	•	•	•
M		•	•	•	•	•	•	•
K								
N								
S							○	○
H								
O								

1) Insert radius >1.6 mm: Modify cutter body

XDKT / XDHT

		-M50 CTCK215 DRAGONSKIN	-R50 CTCK215 DRAGONSKIN	-M50 CTPK220 DRAGONSKIN	-F20 CTWN215	NEW -F10 CTPX715 DRAGONSKIN	-27P H216T
		M	R	M	F	F	F
		XDKT	XDKT	XDKT	XDKT	XDHT	XDHT
		51 037 ...	51 039 ...	51 037 ...	50 478 ...	51 155 ...	50 477 ...
ISO	RE mm						
11T302FR	0,2						
11T304FR	0,4				502	00202	502
11T304SR	0,4	504			504	00402	504
11T308FR	0,8				508	00802	508
11T308SR	0,8	508	508	608			508
11T312FR	1,2					01202	512
11T316FR	1,6					01602	516
11T320FR	2,0				520 ¹⁾	02002 ¹⁾	520 ¹⁾
11T325FR	2,5				525 ¹⁾	02502 ¹⁾	525 ¹⁾
11T332FR	3,2					03202 ¹⁾	532 ¹⁾
11T340FR	4,0					04002 ¹⁾	540 ¹⁾
11T350FR	5,0					05002 ¹⁾	550 ¹⁾
P						○	
M						○	
K		●	●	●	○	●	○
N					●	●	●
S						○	
H							
O					○	○	○

1) Insert radius >1.6 mm: Modify cutter body

XDKT

		-F40 CTC5240 DRAGONSKIN	-F40 CTCS245 DRAGONSKIN	-R60 CTP6215
		F	F	R
		XDKT	XDKT	XDKT
		50 463 ...	51 113 ...	50 464 ...
ISO	RE mm			
11T304ER	0,4			
11T308ER	0,8			
11T308SR	0,8			
11T312ER	1,2			
11T316ER	1,6			
11T320ER	2,0			
11T325ER	2,5			
11T332ER	3,2			
11T340ER	4,0			
P				
M				
K				●
N				
S		●	●	
H				●
O				

1) Insert radius >1.6 mm: Modify cutter body

Milling guide

Cutting data standard values	→ 145-148	Machining strategy	→ 161
Starting Parameter	→ 161	Technical Information	→ 193-198
Chip groove description and overview	→ 199-201	Grade description and overview	→ 202-208

MaxiMill – 211-15 Screw in cutter

▲ Insert radius >2,5 mm: Modify cutter body

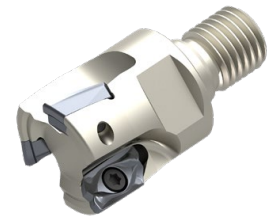
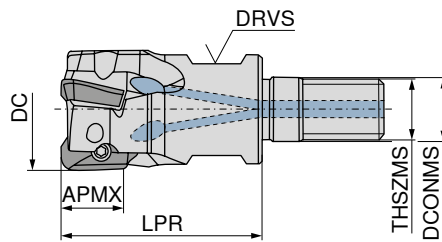
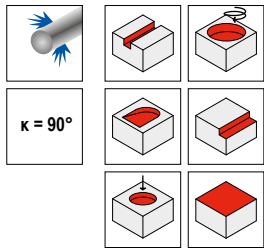

50 746 ...

Designation	DC mm	ZNF	APMX mm	LPR mm	DCONMS mm	THSZMS	DRVS mm	RPMX 1/min.	torque moment Nm	Insert	
G211.25.R.02-15	25	2	14	35	12,5	M12	17	26560	3,2	XD.T 1505	025
G211.32.R.03-15	32	3	14	35	17,0	M16	24	30200	3,2	XD.T 1505	032
G211.40.R.04-15	40	4	14	40	17,0	M16	27	27700	3,2	XD.T 1505	040

MaxiMill – 211-15 End milling cutter

▲ Insert radius >2,5 mm: Modify cutter body

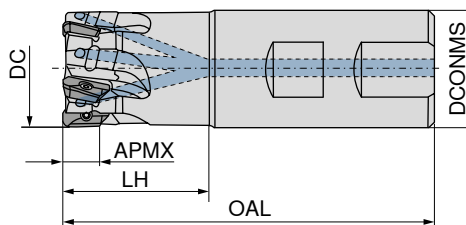
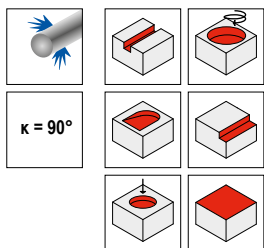

50 747 ...

50 747 ...

Designation	DC mm	ZNF	APMX mm	OAL mm	LH mm	DCONMS mm	RPMX 1/min.	torque moment Nm	Insert		
C211.25.R.02-15-B20-32	25	2	14	83	32	20	26560	3,2	XD.T 1505		125
C211.25.R.02-15-B/A-32	25	2	14	90	32	25	26560	3,2	XD.T 1505	225	025
C211.25.R.02-15-A-50-225	25	2	14	225	50	25	7520	3,2	XD.T 1505	325	
C211.32.R.03-15-B25-40	32	3	14	96	40	25	22160	3,2	XD.T 1505		132
C211.32.R.03-15-A-40	32	3	14	103	40	32	24160	3,2	XD.T 1505	232	
C211.32.R.03-15-B-40	32	3	14	103	40	32	24160	3,2	XD.T 1505		032
C211.32.R.03-15-A-63-250	32	3	14	250	63	32	6800	3,2	XD.T 1505	332	
C211.40.R.04-15-A-50	40	4	14	110	50	32	22160	3,2	XD.T 1505	240	
C211.40.R.04-15-B32-50	40	4	14	110	50	32	22160	3,2	XD.T 1505		040
C211.40.R.03-15-A-50-275	40	3	14	275	50	32	6120	3,2	XD.T 1505	340	

MaxiMill – 211-15 Shell mill

▲ Insert radius >2,5 mm: Modify cutter body

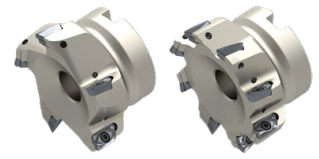
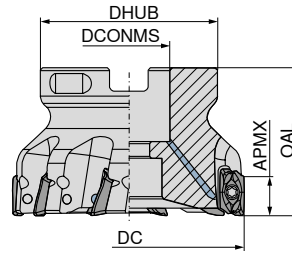
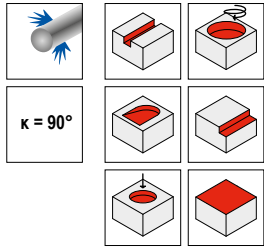

Designation	DC mm	ZNF	APMX mm	OAL mm	DCONMS _{H6} mm	DHUB mm	RPMX 1/min.	torque moment Nm	Insert	50 748 ...		50 749 ...	
A211.40.R.03-15	40	3	14	40	16	38	22160	3,2	XD.T 1505	040			
A211.40.R.04-15	40	4	14	40	16	38	22160	3,2	XD.T 1505				040
A211.50.R.03-15	50	3	14	40	22	43	20320	3,2	XD.T 1505	050			
A211.50.R.05-15	50	5	14	40	22	43	20320	3,2	XD.T 1505				050
A211.63.R.04-15	63	4	14	45	22	48	18640	3,2	XD.T 1505	063			
A211.63.R.06-15	63	6	14	45	22	48	18640	3,2	XD.T 1505				063
A211.80.R.05-15	80	5	14	50	27	58	17040	3,2	XD.T 1505	080			
A211.80.R.08-15	80	8	14	50	27	58	17040	3,2	XD.T 1505				080
A211.100.R.06-15	100	6	14	50	32	78	15680	3,2	XD.T 1505	100			
A211.100.R.10-15	100	10	14	50	32	78	15680	3,2	XD.T 1505				100
A211.125.R.07-15	125	7	14	63	40	88	14320	3,2	XD.T 1505	125			
A211.125.R.11-15	125	11	14	63	40	88	14320	3,2	XD.T 1505				125
A211.160.R.08-15	160	8	14	63	40	93	13200	3,2	XD.T 1505	160 ¹⁾			
A211.160.R.12-15	160	12	14	63	40	93	13200	3,2	XD.T 1505				160 ¹⁾

1) Without Through Coolant

Spare parts DC	TORX® blade	Clamping key – T	Key D	Power Screw	Molykote	Clamping screw	Torque screwdriver
	80 950 ...	80 397 ...	80 950 ...	70 950 ...	70 950 ...	70 950 ...	80 950 ...
25 - 32	054		128		303	839	193
40	054	040	128	151	303	839	193
50	054	050	128	154	303	839	193
63 - 160	054		128		303	839	193

MaxiMill – 211-15KN shell end mill shank

▲ ZEFP = Number of Inserts

▲ ZNP = Number of rows

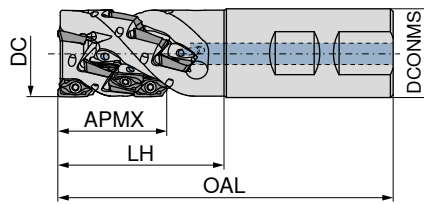
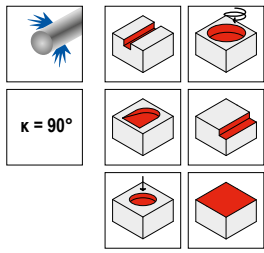

50 783 ...

Designation	DC mm	ZNF	APMX mm	OAL mm	LH mm	DCONMS mm	ZEFP	ZNP	torque moment Nm	Insert	
C211.40.R.03KN3-15-B32-60	40	3	39,6	121	60	32	9	3	3,2	XD.T 1505	04033
C211.50.R.03KN4-15-B40-68	50	3	52,6	138	67	40	12	4	3,2	XD.T 1505	05034

MaxiMill – 211-15KN shell end face mill

▲ ZEFP = Number of Inserts

▲ ZNP = Number of rows

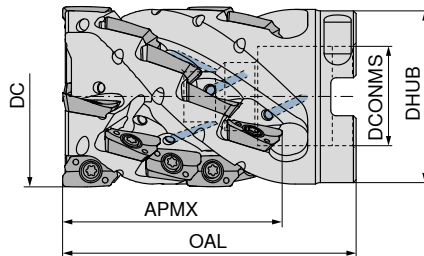
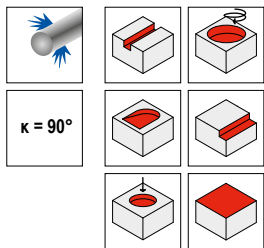

50 781 ...

Designation	DC mm	ZNF	APMX mm	ZEFP	ZNP	OAL mm	DCONMS _{H6} mm	DHUB mm	torque moment Nm	Insert	
A211.50.R.03KN4-15	50	3	52,6	12	4	87	27	48	3,2	XD.T 1505	05034
A211.50.R.03KN5-15	50	3	65,8	15	5	100	27	48	3,2	XD.T 1505	05035
A211.50.R.04KN5-15	50	4	65,8	20	5	100	27	48	3,2	XD.T 1505	05045
A211.63.R.03KN4-15	63	3	52,6	12	4	76	27	58	3,2	XD.T 1505	06334
A211.63.R.03KN5-15	63	3	65,8	15	5	90	27	58	3,2	XD.T 1505	06335
A211.63.R.04KN6-15	63	4	78,5	24	6	102	27	58	3,2	XD.T 1505	06346
A211.63.R.05KN5-15	63	5	65,8	25	5	90	27	58	3,2	XD.T 1505	06355
A211.80.R.04KN5-15	80	4	65,8	20	5	90	32	78	3,2	XD.T 1505	08045
A211.80.R.05KN6-15	80	5	78,5	30	6	102	32	78	3,2	XD.T 1505	08056

Cylindrical screw	TORX® blade	Key D	Molykote	Clamping screw	Socket head screw	Torque screwdriver
70 950 ...	80 950 ...	80 950 ...	70 950 ...	70 950 ...	70 950 ...	80 950 ...

Spare parts

Designation	002	054	128	303	20800	181	193
A211.50.R.03KN4-15	002	054	128	303	20800	181	193
A211.50.R.03KN5-15	002	054	128	303	20800	181	193
A211.50.R.04KN5-15	002	054	128	303	20800	181	193
A211.63.R.03KN4-15	002	054	128	303	20500	181	193
A211.63.R.03KN5-15	002	054	128	303	20500	181	193
A211.63.R.04KN6-15	002	054	128	303	20500	181	193
A211.63.R.05KN5-15	002	054	128	303	20500	181	193
A211.80.R.04KN5-15	004	054	128	303	20500	234	193
A211.80.R.05KN6-15	004	054	128	303	20500	234	193
C211.40.R.03KN3-15-B32-60		054	128	303	20800		193
C211.50.R.03KN4-15-B40-68		054	128	303	20800		193

XDKT

Designation	IC mm	D1 mm	L mm	BS mm	S mm
XDKT 150508..	9,3	4,4	14,8	1,6	5,56
XDKT 150512..	9,3	4,4	14,8	1,6	5,56
XDKT 150516..	9,3	4,4	14,8	1,6	5,56
XDKT 150520..	9,3	4,4	14,8	1,6	5,56
XDKT 150525..	9,3	4,4	14,8	1,6	5,56
XDKT 150530..	9,3	4,4	14,8	1,6	5,56
XDKT 150532..	9,3	4,4	14,8	1,9	5,56
XDKT 150540..	9,3	4,4	14,8	1,2	5,56
XDKT 150560..	9,3	4,4	14,8	-	5,56

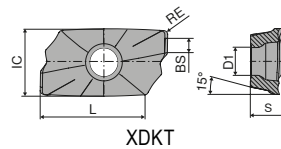

XDKT

-F50 CTCP220 DRAGONSKIN	-M50 CTCP220 DRAGONSKIN	-F50 CTPP225 DRAGONSKIN	-M50 CTPP225 DRAGONSKIN
F XDKT	M XDKT	F XDKT	M XDKT
51 035 ...	51 038 ...	51 035 ...	51 038 ...
258	258	058	058

ISO	RE mm
150508SR	0,8

P	•	•	•	•
M				
K				
N				
S				
H				
O				

XDKT

-F50 CTCP230 DRAGONSKIN	-M50 CTCP230 DRAGONSKIN	-R50 CTCP230 DRAGONSKIN	-F50 CTPP235 DRAGONSKIN	-M50 CTPP235 DRAGONSKIN	-R50 CTPP235 DRAGONSKIN
F XDKT	M XDKT	R XDKT	F XDKT	M XDKT	R XDKT
51 035 ...	51 038 ...	51 040 ...	51 035 ...	51 038 ...	51 040 ...
008	008	008	108	108	108
	012			112	
	016			116	
		020		120	120
	030 ¹⁾			130 ¹⁾	
	040 ¹⁾			140 ¹⁾	

ISO	RE mm
150508SR	0,8
150512SR	1,2
150516SR	1,6
150520SR	2,0
150530SR	3,0
150540SR	4,0

P	•	•	•	•	•
M				○	○
K	○	○	○	○	○
N					
S					
H					
O					

1) Insert radius >2.5 mm: Modify cutter body

XDKT

ISO	RE mm	-F50 CTPM225 DRAGONSKIN F XDKT 51 035 ... 208	-M50 CTPM225 DRAGONSKIN M XDKT 51 038 ... 208	-F50 CTCM235 DRAGONSKIN F XDKT 51 035 ... 308	-M50 CTCM235 DRAGONSKIN M XDKT 51 038 ... 308
150508SR	0,8				
P		•	•	•	•
M		•	•	•	•
K					
N					
S					
H					
O					

XDKT

ISO	RE mm	-F50 CTPM240 DRAGONSKIN F XDKT 51 035 ... 408	-M50 CTPM240 DRAGONSKIN M XDKT 51 038 ... 408	-R50 CTPM240 DRAGONSKIN R XDKT 51 040 ... 408	-F40 CTPM245 DRAGONSKIN F XDKT 51 114 ... 458	-F40 CTCM245 DRAGONSKIN F XDKT 51 114 ... 90801
150508ER	0,8					
150508SR	0,8					
150512ER	1,2					91201
150512SR	1,2					
150516ER	1,6					91601
150516SR	1,6					
150520ER	2,0					92001
150525ER	2,5					92501
150530SR	3,0					
150532ER	3,2					93201 ¹⁾
150540ER	4,0					94001 ¹⁾
150540SR	4,0					
150560ER	6,0					96001 ¹⁾
P		○	○	○	•	•
M		•	•	•	•	•
K						
N						
S						○
H						
O						

1) Insert radius >2.5 mm: Modify cutter body

XDKT

ISO	RE mm	-M50 CTCK215 DRAGONSKIN M XDKT 51 038 ...	-R50 CTCK215 DRAGONSKIN R XDKT 51 040 ...	-M50 CTPK220 DRAGONSKIN M XDKT 51 038 ...	-R50 CTPK220 DRAGONSKIN R XDKT 51 040 ...	-F20 CTWN215 F XDKT 50 479 ...
150508FR	0,8	508	508	608	608	508
150508SR	0,8					

P	
M	
K	•
N	•
S	•
H	
O	○

XDKT

ISO	RE mm	-F40 CTC5240 DRAGONSKIN F XDKT 50 473 ...	-F40 CTCS245 DRAGONSKIN F XDKT 51 114 ...	-R60 CTP6215 R XDKT 50 469 ...
150508ER	0,8	508	558	
150508SR	0,8			300
150532ER	3,2	532 ¹⁾	58201 ¹⁾	
150540ER	4,0	540 ¹⁾	59000 ¹⁾	

P	
M	
K	•
N	
S	•
H	•
O	

1) Insert radius >2.5 mm: Modify cutter body

Milling guide

Cutting data standard values	→ 145-148	Machining strategy	→ 162
Starting Parameter	→ 162	Technical Information	→ 193-198
Chip groove description and overview	→ 199-201	Grade description and overview	→ 202-208

MaxiMill – 211-20 Shell mill

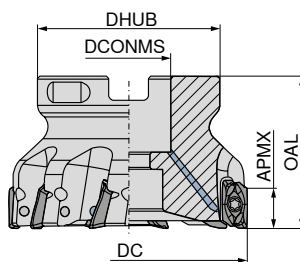
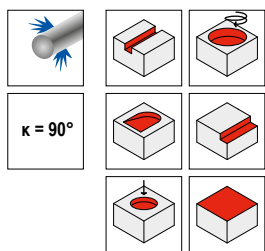

50 778 ...

Designation	DC mm	ZNF	APMX mm	OAL mm	DCONMS _{H6} mm	DHUB mm	RPMX 1/min.	torque moment Nm	Insert	
A211.63.R.05-20	63	5	19	45	22	48	14400	5	XD.. 2007..	06305
A211.80.R.06-20	80	6	19	50	27	58	12400	5	XD.. 2007..	08006
A211.100.R.07-20	100	7	19	50	32	78	10900	5	XD.. 2007..	10007

MaxiMill – 211-20K shell end face mill

▲ ZEFP = Number of Inserts
▲ ZNP = Number of rows

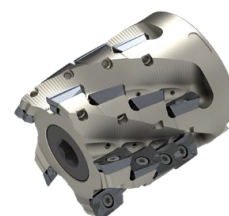
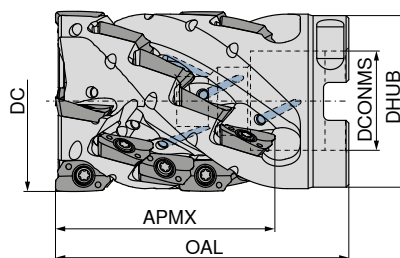
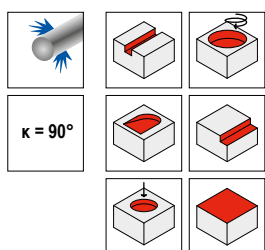

50 780 ...

Designation	DC mm	ZNF	APMX mm	ZEFP	ZNP	OAL mm	DCONMS _{H6} mm	DHUB mm	torque moment Nm	Insert	
A211.63.R.04K4-20	63	4	68	16	4	92	27	58	5	XD.. 2007..	06304
A211.80.R.05K4-20	80	5	68	20	4	92	32	76	5	XD.. 2007..	08005

Spare parts

DC	Cylindrical screw	TORX® blade	Key D	Molykote	Clamping screw	Socket head screw	Torque screwdriver
63		037	106	303	01200	180	193
80		037	106	303	01200	181	193
63	003	037	106	303	01200	181	193
80	004	037	106	303	01200	234	193
100		037	106	303	01200		193

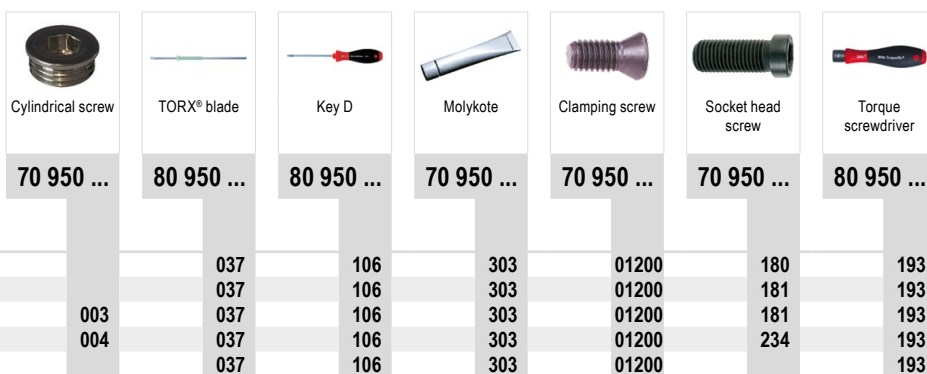

XDKT

Designation	IC mm	D1 mm	L mm	S mm
XDKT 200708..	12,5	5,5	18,8	6,93
XDKT 200716..	12,5	5,5	18,8	6,89
XDKT 200732..	12,5	5,5	18,8	6,82
XDKT 200740..	12,5	5,5	18,8	6,80
XDKT 200760..	12,5	5,5	18,8	6,80

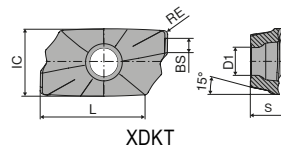

XDKT

		-M50 CTPP235 DRAGONSKIN	-M50 CTCP230 DRAGONSKIN	-F40 CTPM245 DRAGONSKIN	-F40 CTCM245 DRAGONSKIN	-M50 CTPK220 DRAGONSKIN	-F40 CTC5240 DRAGONSKIN	-F40 CTCS245 DRAGONSKIN	
		M	M	F	F	M	F	F	
		XDKT	XDKT	XDKT	XDKT	XDKT	XDKT	XDKT	
		51 145 ...	51 145 ...	51 127 ...	51 127 ...	51 145 ...	51 127 ...	51 127 ...	
ISO	RE mm								
200708ER	0,8	10800	00800	45800	90801	60800	15800	55800	
200716ER	1,6	11600	01600	46600	91601	61600	16600	56600	
200732ER	3,2			48200	93201		18200	58200	
200740ER	4,0				94001		19000		
200760ER	6,0				96001		19200		
P		●	●	●	●				
M		○							
K		○	○			●			
N									
S					○		●	●	
H									
O									

Milling guide

Cutting data standard values	→ 145-148	Machining strategy	→ 163
Starting Parameter	→ 163	Technical Information	→ 193-198
Chip groove description and overview	→ 199-201	Grade description and overview	→ 202-208

MaxiMill – 490-09 Screw in cutter

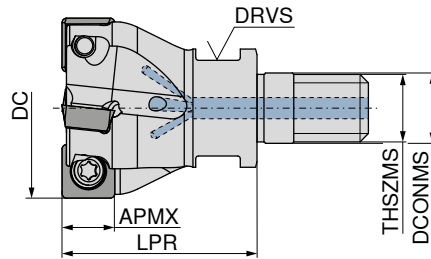
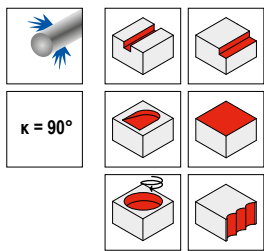

50 726 ...

Designation	DC mm	ZNF	APMX mm	LPR mm	THSZMS mm	DCONMS mm	DRVS mm	torque moment Nm	Insert	
G490.25.R.03-09	25	3	8	35	M12	12,5	17	3,2	SD..09T3..	025
G490.32.R.04-09	32	4	8	35	M16	17,0	24	3,2	SD..09T3..	032

MaxiMill – 490-09 End milling cutter

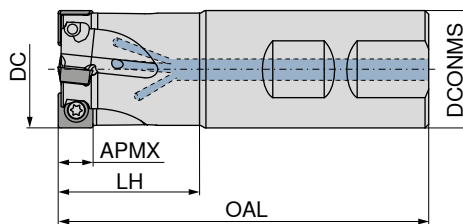
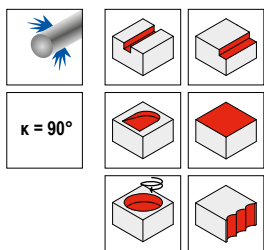

50 727 ...

50 727 ...

Designation	DC mm	ZNF	APMX mm	DCONMS mm	OAL mm	LH mm	torque moment Nm	Insert	
C490.25.R.03-09-B-32	25	3	8	25	88	32	3,2	SD..09T3..	025
C490.25.R.02-09-A-20	25	2	8	20	165	40	3,2	SD..09T3..	225
C490.25.R.02-09-A-40-165	25	2	8	25	165	40	3,2	SD..09T3..	125
C490.32.R.04-09-B-25	32	4	8	25	100	40	3,2	SD..09T3..	132
C490.32.R.04-09-B-40	32	4	8	32	100	40	3,2	SD..09T3..	032

MaxiMill – 490-09 Shell mill

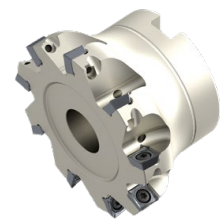
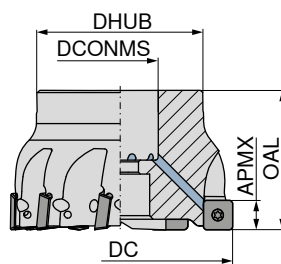
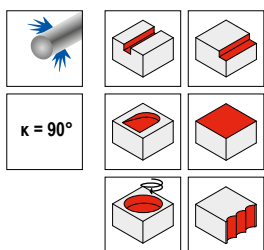

50 728 ...

Designation	DC mm	ZNF	APMX mm	DHUB mm	DCONMS _{H6} mm	OAL mm	torque moment Nm	Insert	
A490.40.R.05-09	40	5	8	38	16	40	3,2	SD..09T3..	040
A490.42.R.06-09	42	6	8	38	16	40	3,2	SD..09T3..	042
A490.50.R.06-09	50	6	8	43	22	40	3,2	SD..09T3..	050
A490.52.R.07-09	52	7	8	43	22	40	3,2	SD..09T3..	052
A490.63.R.07-09	63	7	8	48	22	40	3,2	SD..09T3..	063
A490.66.R.08-09	66	8	8	48	22	40	3,2	SD..09T3..	066
A490.80.R.09-09	80	9	8	58	27	50	3,2	SD..09T3..	080
A490.100.R.10-09	100	10	8	78	32	50	3,2	SD..09T3..	100

MaxiMill – 490-09K shell end face mill

▲ ZEFP = Number of Inserts
▲ ZNP = Number of rows

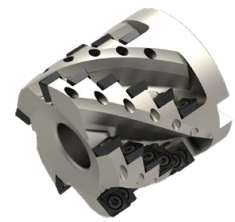
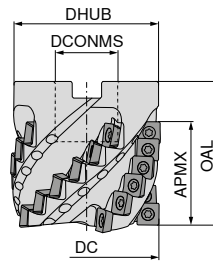
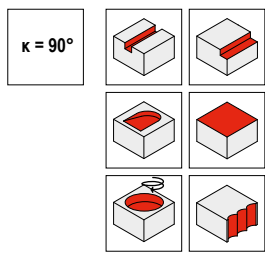

50 761 ...

Designation	DC mm	ZNF	APMX mm	ZEFP	ZNP	OAL mm	DCONMS _{H6} mm	DHUB mm	torque moment Nm	Insert	
A490.40.R.03K6-09	40	3	41	18	6	55	16	38	3,2	SD..09T3..	040
A490.50.R.04K6-09	50	4	41	24	6	55	22	48	3,2	SD..09T3..	050
A490.63.R.05K6-09	63	5	41	30	6	60	27	61	3,2	SD..09T3..	063

Spare parts

DC	TORX® blade	Clamping key – T	Key D	Power Screw	Molykote	Clamping screw	Torque screwdriver
25 - 32	80 950 ...	80 397 ...	80 950 ...	70 950 ...	70 950 ...	70 950 ...	80 950 ...
40 - 42			036	113	151	110	192
50 - 100		040	036	113		110	192

MaxiMill – 490-09 Adjustable single angle milling cutter

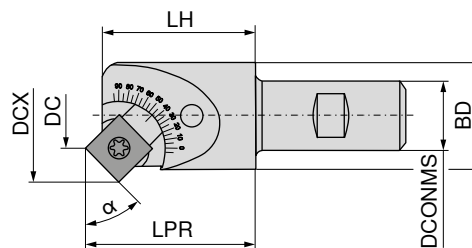
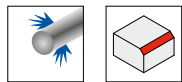

NEW

50 690 ...

Designation	DC mm	DCX mm	LH mm	BD mm	LPR mm	ZNF	DCONMS mm	torque moment Nm	Insert	
C490.20.R.01	1,6 - 11,1	20,1 - 23,6	32	18,65	32,9 - 34,6	1	16	3,2	SD..09T3..	01600

Spare parts for Article no. 50 690 01600

Cylindrical screw	Adjustment wedge	TORX® blade	Key D	Molykote	Clamping screw	Torque screwdriver
70 950 ...	70 950 ...	80 950 ...	80 950 ...	70 950 ...	70 950 ...	80 950 ...
87500	87200	036	113	303	110	192

Angle-dependent dimensions can be found on → Page 164

SDHT / SDNT

Designation	IC mm	D1 mm	L mm	BS mm	S mm
SD.T 09T3..	9,52	4,4	9,52	2,5	3,97

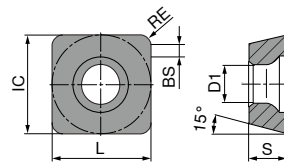

SDHT / SDNT

ISO	RE mm	TCM10	-29 CTCP230 DRAGONSKIN	CTPP235 DRAGONSKIN	-29 CTPP235 DRAGONSKIN	-33 CTPM240 DRAGONSKIN	-F50 CTPM245 DRAGONSKIN	-F50 CTCM245 DRAGONSKIN
		CERMET SDHT	SDNT	SDNT	SDNT	SDNT	SDNT	SDNT
		50 424 ...	51 011 ...	51 082 ...	51 011 ...	51 030 ...	51 111 ...	51 111 ...
09T308ER	0,8			108	108		458	90801
09T308SR	0,8	900	008		108	408		
P		●	●	●	●	○	●	●
M				○	○	●	●	●
K		○	○	○	○			
N								
S								○
H								
O								

SDNT / SDHT

ISO	RE mm	-31 CTCK215 DRAGONSKIN	NEW -F10 CTPX715 DRAGONSKIN	-27P H216T	-27 CTC5240 DRAGONSKIN	-M31 CTC5240 DRAGONSKIN	-F10 CTCS245 DRAGONSKIN
		SDNT	SDHT	SDHT	SDHT	SDNT	SDHT
		51 029 ...	51 125 ...	50 424 ...	50 496 ...	50 425 ...	51 125 ...
09T308ER	0,8			550	508	508	55800
09T308FR	0,8		00802				
09T308SR	0,8	508					
P			○				
M			○				
K		●	●	○			
N			●	●			
S			○		●	●	●
H							
O			○	○			

Milling guide

Cutting data standard values	→ 145-148	Starting Parameter	→ 164
Technical Information	→ 193-198	Chip groove description and overview	→ 199-201
Grade description and overview	→ 202-208		

MaxiMill – 490-12 Shell mill

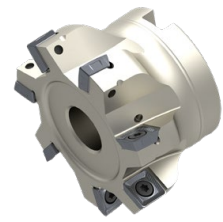
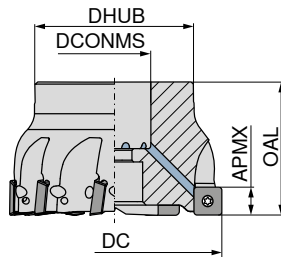
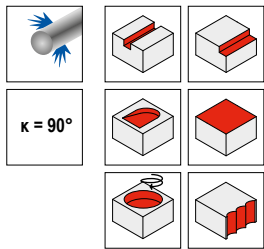

50 703 ...

Designation	DC mm	ZNF	APMX mm	DHUB mm	DCONMS mm	OAL mm	torque moment Nm	Insert	
A490.40.R.04-12	40	4	11	38	16	40	5	SD.. 1205..	54000
A490.50.R.05-12	50	5	11	43	22	40	5	SD.. 1205..	550
A490.63.R.06-12	63	6	11	48	22	40	5	SD.. 1205..	563
A490.80.R.07-12	80	7	11	58	27	50	5	SD.. 1205..	580
A490.100.R.08-12	100	8	11	75	32	50	5	SD.. 1205..	600
A490.125.R.10-12	125	10	11	88	40	63	5	SD.. 1205..	625

Spare parts

DC	TORX® blade	Clamping key – T	Key D	Power Screw	Molykote	Clamping screw	Torque screwdriver
40	80 950 ...	80 397 ...	80 950 ...	70 950 ...	70 950 ...	70 950 ...	80 950 ...
50							
63 - 125							

MaxiMill – 490-12 Adjustable single angle milling cutter

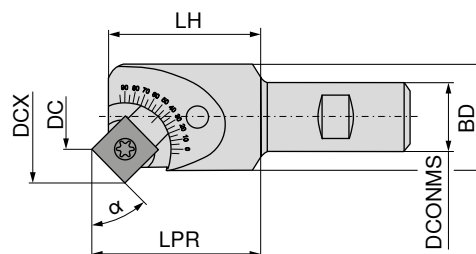
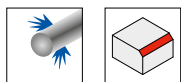

NEW

50 690 ...

Designation	DC mm	DCX mm	LH mm	BD mm	LPR mm	ZNF	DCONMS mm	torque moment Nm	Insert	
C490.26.R.01	1,1 - 14,1	26,6 - 31,5	37	25	38,2 - 40,6	1	20	5	SD.. 1205..	02000

Spare parts
for Article no.
50 690 02000

Cylindrical screw	Adjustment wedge	TORX® blade	Key D	Molykote	Clamping screw	Torque screwdriver
70 950 ...	70 950 ...	80 950 ...	80 950 ...	70 950 ...	70 950 ...	80 950 ...
87400	87300	037	114	303	01200	193

Angle-dependent dimensions can be found on → Page 165

SDHW / SDMT / SDHT

Designation	IC mm	D1 mm	L mm	BS mm	S mm
SDH. 120508..	12,7	5,5	12,7	2,2	5,00
SDHT 120512..	12,7	5,5	12,7	1,8	5,00
SDHT 120520..	12,7	5,5	12,7	1,0	5,00
SDHT 120525..	12,7	5,5	12,7	1,5	5,00
SDMT 120508..	12,7	5,5	12,7	3,0	5,00
SDMT 1205ZZ..	12,7	5,5	12,7	0,9	5,00

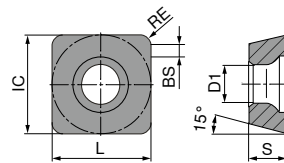

SDHW / SDMT / SDHT

ISO	RE mm	TCM10	-29 CTCP230 DRAGONSKIN	-29 CTPP235 DRAGONSKIN	-29 CTPM240 DRAGONSKIN	-33 CTPM240 DRAGONSKIN	-F50 CTPM245 DRAGONSKIN	-F50 CTCM245 DRAGONSKIN
		CERMET SDHW	SDMT	SDMT	SDMT	SDHT	SDMT	SDMT
		50 428 ...	51 081 ...	51 081 ...	51 081 ...	51 028 ...	51 110 ...	51 110 ...
120508ER	0,8	901	020	120	420	412 421	458	90801
120508SR	0,8							
120512SR	1,2							
120520SR	2,0							
1205ZZSN	0,8							
P		●	●	●	○	○	●	●
M				○	●	●	●	●
K		○	○	○				
N								
S								○
H								
O								

SDMT / SDHT

ISO	RE mm	-31 CTCK215 DRAGONSKIN	NEW -F10 CTPX715 DRAGONSKIN	-27P H216T	-M31 CTC5240 DRAGONSKIN	-F50 CTCS245 DRAGONSKIN
		SDMT	SDHT	SDHT	SDMT	SDMT
		51 059 ...	51 161 ...	50 426 ...	50 580 ...	51 110 ...
120508ER	0,8	521	00802	555 559	508	55800
120508FR	0,8					
120525FR	2,5					
1205ZZSN	0,8					
P				○		
M				○		
K		●	●	○		
N			●	●		
S			○		●	●
H						
O				○		○

Milling guide

Cutting data standard values	→ 145-148	Starting Parameter	→ 165
Technical Information	→ 193-198	Chip groove description and overview	→ 199-201
Grade description and overview	→ 202-208		

MaxiMill – HSC-11 Screw in cutter

▲ Insert radius >3.2 mm: Modify cutter body

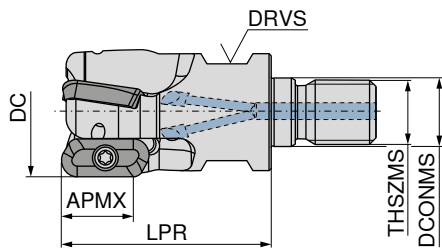
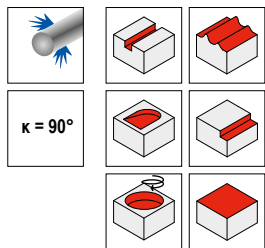

55 107 ...

Designation	DC mm	ZNF	APMX mm	DCONMS mm	LPR mm	THSZMS mm	RPMX 1/min.	DRVS mm	torque moment Nm	Insert	
GHSC.16.R.02-11	16	2	10	8,5	27	M8	56000	10	1,8	XDHT 11T3..	016
GHSC.20.R.02-11	20	2	10	10,5	33	M10	50100	15	1,8	XDHT 11T3..	020
GHSC.25.R.03-11	25	3	10	12,5	35	M12	45000	17	1,8	XDHT 11T3..	025
GHSC.32.R.03-11	32	3	10	17,0	35	M16	39800	24	1,8	XDHT 11T3..	032
GHSC.40.R.03-11	40	3	10	17,0	35	M16	35500	24	1,8	XDHT 11T3..	040

MaxiMill – HSC-11 End milling cutter

▲ Insert radius >3.2 mm: Modify cutter body

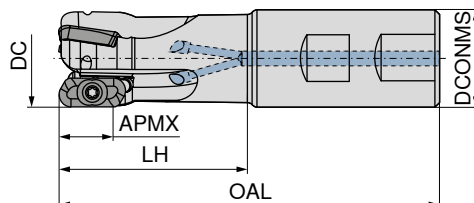
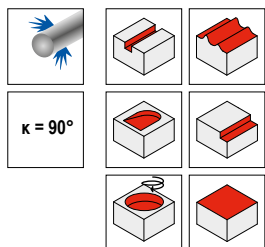

50 675 ... 50 675 ...

Designation	DC mm	ZNF	APMX mm	DCONMS _{h6} mm	OAL mm	LH mm	RPMX 1/min.	torque moment Nm	Insert		
CHSC.16.R.02-11-B/A-25	16	2	10	16	75	25	56200	1,8	XDHT 11T3..	016	416
CHSC.16.R.02-11-A-32	16	2	10	16	165	32	18800	1,8	XDHT 11T3..	116	
CHSC.20.R.02-11-A-32	20	2	10	20	84	32	50100	1,8	XDHT 11T3..	020	
CHSC.20.R.03-11-B-32	20	3	10	20	84	32	50100	1,8	XDHT 11T3..		420
CHSC.20.R.02-11-A-40	20	2	10	20	165	40	26700	1,8	XDHT 11T3..	120	
CHSC.25.R.03-11-A-40	25	3	10	25	98	40	45000	1,8	XDHT 11T3..	225	
CHSC.25.R.04-11-B-40	25	4	10	25	98	40	45000	1,8	XDHT 11T3..		425
CHSC.25.R.02-11-A-50	25	2	10	25	165	50	31700	1,8	XDHT 11T3..	125	
CHSC.25.R.03-11-A-50	25	3	10	25	165	50	31700	1,8	XDHT 11T3..	325	

MaxiMill – HSC-11 Shell mill

▲ Insert radius >3.2 mm: Modify cutter body

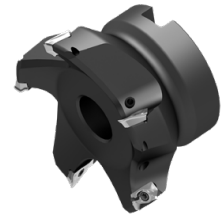
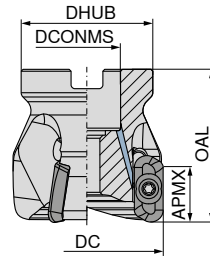
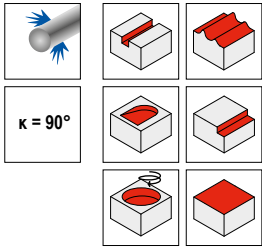

50 718 ...

Designation	DC mm	ZNF	APMX mm	DCONMS _{H6} mm	DHUB mm	OAL mm	RPMX 1/min.	torque moment Nm	Insert	
AHSC.40.R.04-11	40	4	10	16	38	50	35500	1,8	XDHT 11T3..	040
AHSC.50.R.04-11	50	4	10	22	43	50	31800	1,8	XDHT 11T3..	050
AHSC.63.R.05-11	63	5	10	22	43	50	28300	1,8	XDHT 11T3..	063
AHSC.80.R.05-11	80	5	10	27	58	50	25100	1,8	XDHT 11T3..	080
AHSC.100.R.05-11	100	5	10	32	78	50	22400	1,8	XDHT 11T3..	100

Spare parts	TORX® blade	Clamping key – T	Key D	Power Screw	Molykote	Clamping screw	Torque screwdriver
DC	80 950 ...	80 397 ...	80 950 ...	70 950 ...	70 950 ...	70 950 ...	80 950 ...
16 - 25	043		125		303	128	192
32	043		125		303	131	192
40	043	040	125	151	303	131	192
50 - 63	043	050	125	154	303	131	192
80 - 100	043		125		303	131	192

XDKT / XDHT

Designation	IC mm	D1 mm	L mm	BS mm	S mm
XD.T 11T302FR	6,8	2,8	10,6	2	3,80
XD.T 11T304FR	6,8	2,8	10,6	1,8	3,80
XD.T 11T308FR	6,8	2,8	10,6	1,4	3,80
XD.T 11T320FR	6,8	2,8	10,6	1,4	3,80
XD.T 11T325FR	6,8	2,8	10,6	1,4	3,80
XDHT 11T312FR	6,8	2,8	10,6	1,4	3,80
XDHT 11T316FR	6,8	2,8	10,6	1,4	3,80
XDHT 11T332FR	6,8	2,8	10,6	0,8	3,80
XDHT 11T340FR	6,8	2,8	10,6	-	3,80
XDHT 11T350FR	6,8	2,8	10,6	-	3,80

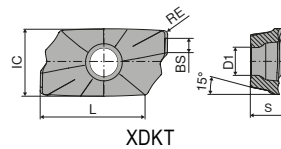

XDKT / XDHT

ISO	RE mm
11T302FR	0,2
11T304FR	0,4
11T308FR	0,8
11T312FR	1,2
11T316FR	1,6
11T320FR	2,0
11T325FR	2,5
11T332FR	3,2
11T340FR	4,0
11T350FR	5,0

-F20 CTWN215		-27P H216T	
F XDKT		F XDHT	
50 478 ...		50 477 ...	
502		502	
504		504	
508		508	
		512	
		516	
520 ¹⁾		520 ¹⁾	
525 ¹⁾		525 ¹⁾	
		532 ¹⁾	
		540 ¹⁾	
		550 ¹⁾	

P		
M		
K		○
N		●
S		
H		
O		○

1) Insert radius >1.6 mm: Modify cutter body

Milling guide

Safety advice	→ 166	Cutting data standard values	→ 167
Machining strategy	→ 168+169	Technical Information	→ 193-198
Chip groove description and overview	→ 199-201	Grade description and overview	→ 202-208

MaxiMill – HSC-19 Screw-in cutter

▲ Insert radius >4.0 mm: Modify cutter body

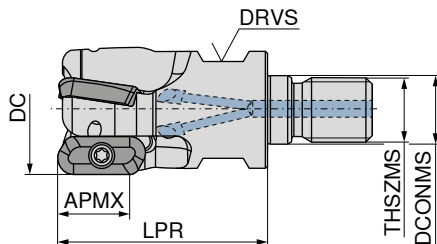
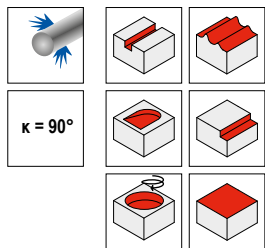

55 108 ...

Designation	DC mm	ZNF	APMX mm	DCONMS mm	LPR mm	THSZMS	DRVS mm	RPMX 1/min.	torque moment Nm	Insert	
GHSC.25.R.02-19	25	2	18	12,5	45	M12	17	34400	5	XDHT 1904..	025
GHSC.32.R.03-19	32	3	18	17,0	52	M16	24	29100	5	XDHT 1904..	032
GHSC.40.R.03-19	40	3	18	17,0	52	M16	24	24900	5	XDHT 1904..	040

MaxiMill – HSC-19 End milling cutter

▲ Insert radius >4.0 mm: Modify cutter body

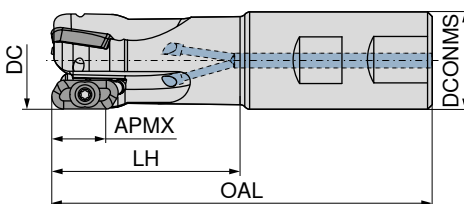
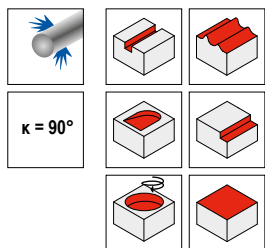

50 679 ...

50 679 ...

Designation	DC mm	ZNF	APMX mm	DCONMS _{h5} mm	OAL mm	LH mm	RPMX 1/min.	torque moment Nm	Insert		
CHSC.25.R.02-19-A-50	25	2	18	25	121	50	32400	5	XDHT 1904..	225	
CHSC.25.R.02-19	25	2	18	25	121	65	32400	5	XDHT 1904..		025
CHSC.25.R.02-19-A-63	25	2	18	25	165	63	24700	5	XDHT 1904..	325	
CHSC.32.R.02-19-A-63	32	2	18	32	125	63	28900	5	XDHT 1904..	232	
CHSC.32.R.03-19-A-63	32	3	18	32	125	63	28900	5	XDHT 1904..	432	
CHSC.32.R.03-19	32	3	18	32	125	65	28900	5	XDHT 1904..		033
CHSC.32.R.02-19	32	2	18	32	125	65	28900	5	XDHT 1904..		032
CHSC.32.R.02-19-A-80	32	2	18	32	165	80	24400	5	XDHT 1904..	332	
CHSC.32.R.03-19-A-80	32	3	18	32	165	80	24400	5	XDHT 1904..	532	

MaxiMill – HSC-19 Shell mill

▲ Insert radius >4.0 mm: Modify cutter body

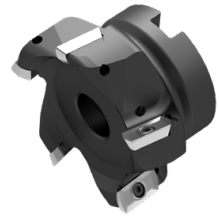
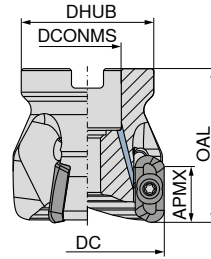
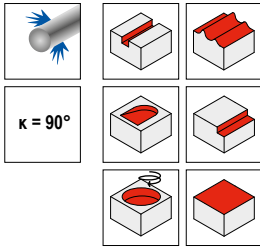

50 716 ...

Designation	DC mm	ZNF	APMX mm	DCONMS _{H8} mm	DHUB mm	OAL mm	RPMX 1/min.	torque moment Nm	Insert	
AHSC.40.R.03-19	40	3	18	16	38	50	24900	5	XDHT 1904..	040
AHSC.50.R.04-19	50	4	18	22	43	50	21600	5	XDHT 1904..	050
AHSC.63.R.04-19	63	4	18	22	48	50	18800	5	XDHT 1904..	163
AHSC.63.R.05-19	63	5	18	22	48	50	18800	5	XDHT 1904..	063
AHSC.80.R.04-19	80	4	18	27	58	50	16400	5	XDHT 1904..	180
AHSC.80.R.05-19	80	5	18	27	58	50	16400	5	XDHT 1904..	080
AHSC.100.R.04-19	100	4	18	32	78	50	14500	5	XDHT 1904..	200
AHSC.100.R.05-19	100	5	18	32	78	50	14500	5	XDHT 1904..	100
AHSC.125.R.05-19	125	5	18	40	88	63	12800	5	XDHT 1904..	125
AHSC.125.R.06-19	125	6	18	40	88	63	12800	5	XDHT 1904..	225

Spare parts
DC

DC	TORX® blade 80 950 ...	Clamping key – T 80 397 ...	Key D 80 950 ...	Power Screw 70 950 ...	Molykote 70 950 ...	Clamping screw 70 950 ...	Torque screwdriver 80 950 ...
25	036		113		303	172	193
32	036		113		303	173	193
40	036	040	113	151	303	173	193
50 - 63	036	050	113	154	303	174	193
80 - 125	036		113		303	174	193

XDHT

Designation	IC mm	D1 mm	L mm	BS mm	S mm
XDHT 190402..	9,52	4,65	19	2	4,76
XDHT 190404..	9,52	4,65	19	2	4,76
XDHT 190408..	9,52	4,65	19	2	4,76
XDHT 190412..	9,52	4,65	19	2	4,76
XDHT 190416..	9,52	4,65	19	2	4,76
XDHT 190420..	9,52	4,65	19	2	4,76
XDHT 190425..	9,52	4,65	19	1,4	4,76
XDHT 190432..	9,52	4,65	19	1	4,76
XDHT 190440..	9,52	4,65	19	1	4,76
XDHT 190450..	9,52	4,65	19	-	4,76

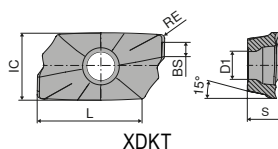

XDHT

NEW

-F10
CTPX715

-27P
H216T

DRAGONSKIN

F **F**
XDHT XDHT

51 159 ... **50 487 ...**

ISO	RE mm		
190402FR	0,2		
190404FR	0,4		
190408FR	0,8		
190412FR	1,2		
190416FR	1,6		
190420FR	2,0		
190425FR	2,5		
190432FR	3,2		
190440FR	4,0		
190450FR	5,0		
P		○	
M		○	
K		●	○
N		●	●
S		○	
H			
O		○	○

1) Insert radius > 4.0 mm: Modify cutter body

Milling guide

Cutting data standard values	→ 145-148	Safety advice	→ 166
Machining strategy	→ 170-172	Technical Information	→ 193-198
Chip groove description and overview	→ 199-201	Grade description and overview	→ 202-208

MaxiMill – HPC 12 Shell mill

- ▲ 50 723 ... normal pitch
- ▲ 50 724 ... fine pitch

Scope of supply:

Tool, adjustment wedges and setting key; incl. wooden box

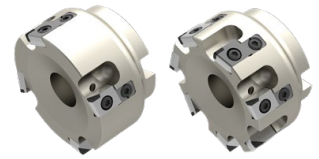
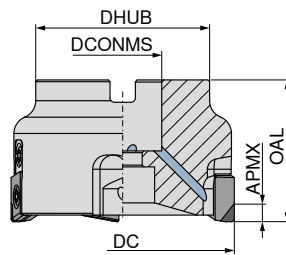
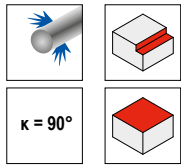





Designation	DC mm	ZNF	APMX mm	OAL mm	DHUB mm	DCONMS _{H6} mm	RPMX 1/min.	torque moment Nm	Insert	50 723 ...	50 724 ...
AHPC.40.R.04-12	40	4	11	40	34	16	32000	5	ZNHW 1205..	040	
AHPC.50.R.04-12	50	4	11	40	49	22	32000	5	ZNHW 1205..	050	
AHPC.50.R.05-12	50	5	11	40	49	22	32000	5	ZNHW 1205..		050
AHPC.63.R.04-12	63	4	11	40	49	22	29000	5	ZNHW 1205..	063	
AHPC.63.R.07-12	63	7	11	40	49	22	29000	5	ZNHW 1205..		063
AHPC.80.R.05-12	80	5	11	50	60	27	26000	5	ZNHW 1205..	080	
AHPC.80.R.09-12	80	9	11	50	60	27	26000	5	ZNHW 1205..		080
AHPC.100.R.06-12	100	6	11	50	70	32	24000	5	ZNHW 1205..	100	
AHPC.100.R.12-12	100	12	11	50	70	32	24000	5	ZNHW 1205..		100
AHPC.125.R.08-12	125	8	11	63	72	40	22000	5	ZNHW 1205..	125	
AHPC.125.R.14-12	125	14	11	63	72	40	22000	5	ZNHW 1205..		12514
AHPC.160.R.10-12	160	10	11	63	118	40	18000	5	ZNHW 1205..	16010 ¹⁾	
AHPC.160.R.16-12	160	16	11	63	118	40	18000	5	ZNHW 1205..		16016 ¹⁾
AHPC.200.R.12-12	200	12	11	63	153	60	16000	5	ZNHW 1205..	20000 ¹⁾	
AHPC.250.R.14-12	250	14	11	63	200	60	14000	5	ZNHW 1205..	25014 ¹⁾	
AHPC.315.R.18-12	315	18	11	80	265	60	12000	5	ZNHW 1205..	31518 ¹⁾	

1) Without Through Coolant

Spare parts

DC

40 - 315

 TORX® blade	 Molykote	 Clamping screw	 Wedge	 Torque screwdriver
80 950 ...	70 950 ...	70 950 ...	70 950 ...	80 950 ...
036	303	174	199	193

ZNHW

Designation	LE mm	D1 mm	IC mm	S mm
ZNHW 120504ER-1503	3	4,85	10	5,40
ZNHW 120504FR-0007	7	4,85	10	5,40
ZNHW 120508ER-1503	3	4,85	10	5,40
ZNHW 120508SR-0003	3	4,85	10	5,40
ZNHW 1205EOER-1002	2	4,85	10	5,40
ZNHW 1205POER-1511	11	4,85	10	5,40
ZNHW 1205POFR-1003	3	4,85	10	5,40
ZNHW 1205POSR-1503	3	4,85	10	5,40
ZNHW 1205POSR-1506	6	4,85	10	5,40
ZNHW 1205POSR-3003	3	4,85	10	5,40
ZNHW 1205ZZSR-5003	3	4,85	10	5,40

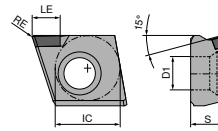

ZNHW

ISO	RE mm	CTL3215 CBN ZNHW 50 515 ...	CTD4205 DIAMOND ZNHW 50 467 ...	-R CTD4205 DIAMOND ZNHW 50 517 ...	CTD4205 DIAMOND ZNHW 50 468 ...	-Q CTD4205 DIAMOND ZNHW 50 466 ...
120504ER-1503	0,4				906	
120504FR-0007	0,4				904	
120508ER-1503	0,8				910	
120508SR-0003	0,8				908	
1205EOER-1002		952				
1205POER-1511			902			
1205POFR-1003			90600			
1205POSR-1503			900			
1205POSR-1506			90800	90800		
1205POSR-3003			904			
1205ZZSR-5003						900 ¹⁾
P						
M						
K		•				
N			•	•	•	•
S						
H		○				
O			○	○	○	○

1) -Q = trailing edge insert

Milling guide

Cutting data standard values	→ 145–148	Machining strategy	→ 173
Technical Information	→ 193–198	Chip groove description and overview	→ 199–201
Grade description and overview	→ 202–208		

MaxiMill – 242 Chamfer Cutter

- ▲ Caution: Use only inserts with a corner radius of less than 1.6 mm
- ▲ ZEFP = number of inserts
- ▲ ZNP = tooth rows

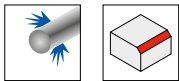

$\kappa = 45^\circ$

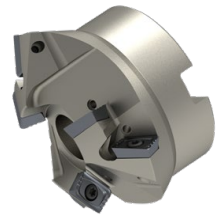
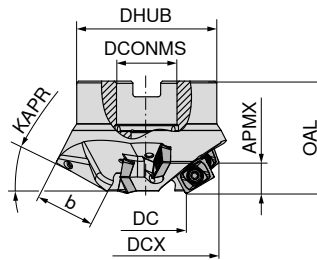

NEW

50 768 ...

KAPR	DC mm	DCX mm	ZNF	APMX mm	ZEFP	$b_{\pm 0,3}$ mm	OAL mm	DCONMS mm	DHUB mm	ZNP	torque moment Nm	Insert	
15°	35	89,60	3	7,0	6	27,6	50	27	62,5	2	3,2	LD.. 15...	11503
30°	35	83,60	3	13,6	6	27,6	50	27	62,5	2	3,2	LD.. 15...	13003
45°	35	74,60	3	19,3	6	27,6	50	27	62,5	2	3,2	LD.. 15...	14503
60°	35	62,70	3	23,6	6	27,6	50	22	49,0	2	3,2	LD.. 15...	16003
75°	35	49,48	3	26,7	6	27,6	60	22	49,0	2	3,2	LD.. 15...	17503¹⁾

1) Version with Powerscrew

Spare parts	TORX® blade	Clamping key – T	Key D	Power Screw	Molykote	Clamping screw	Torque screwdriver	clamping screw
KAPR								
15 - 60								
75								
	80 950 ...	80 397 ...	80 950 ...	70 950 ...	70 950 ...	70 950 ...	80 950 ...	83 950 ...
	036	050	113	154	303	304	192	125
	036	050	113	154	303	304	192	125

LDFT / LDFW / LDMT

Designation	IC mm	D1 mm	L mm	BS mm	S mm
LD.. 1504PD..	9,52	4,4	15	1,2	4,76
LDFT 150408..	9,52	4,4	15	1,2	4,76
LDFT 1504PD..	9,52	4,4	15	0,8	4,76

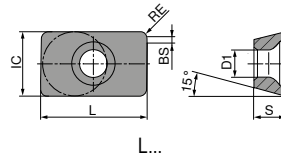

LDMT / LDFT / LDFW

ISO	RE mm	LDMT 51 080 ...	LDMT 51 080 ...	LDFT 51 042 ...	LDFW 51 043 ...	LDFT 51 157 ...	LDFT 50 409 ...
150408FR	0,8	020	120	420	520	00802	550
1504PDSR	0,8						
1504PDSR	1,2						

	P	M	K	N	S	H	O
LDMT 51 080 ...	●		○				
LDMT 51 080 ...		○	○				
LDFT 51 042 ...		●					
LDFW 51 043 ...			●				
LDFT 51 157 ...			●	●	○		
LDFT 50 409 ...			○	●			○

Milling guide

Cutting data standard values	→ 145-148	Technical Information	→ 193-198
Chip groove description and overview	→ 199-201	Grade description and overview	→ 202-208

MaxiMill – HFC high-feed screw-in cutter

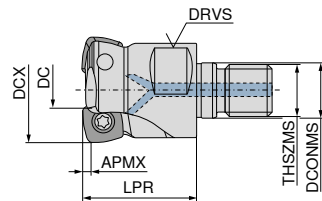
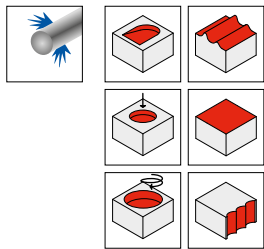

50 682 ...

Designation	DC mm	DCX mm	ZNF	APMX mm	LPR mm	DCONMS mm	THSZMS	DRVS mm	RPMX 1/min.	torque moment Nm	Insert	
GHFC.16.R.02-06	7	16	2	0,8	27	8,5	M8	10	20800	1,2	XPLX 0603..	616
GHFC.20.R.03-06	11	20	3	0,8	33	10,5	M10	15	19800	1,2	XPLX 0603..	620
GHFC.25.R.04-06	16	25	4	0,8	35	12,5	M12	17	18700	1,2	XPLX 0603..	625
GHFC.32.R.05-06	23	32	5	0,8	35	17,0	M16	24	22000	1,2	XPLX 0603..	632
GHFC.42.R.07-06	33	42	7	0,8	35	17,0	M16	24	15000	1,2	XPLX 0603..	04207
GHFC.25.R.02-09	12	25	2	1,0	35	12,5	M12	17	30000	3,2	XDLX 09T3..	025
GHFC.25.R.03-09	12	25	3	1,0	35	12,5	M12	17	30000	3,2	XDLX 09T3..	125
GHFC.32.R.03-09	19	32	3	1,0	35	17,0	M16	24	27000	3,2	XDLX 09T3..	032
GHFC.42.R.05-09	19	42	5	1,0	35	17,0	M16	24	26100	3,2	XDLX 09T3..	04205
GHFC.32.R.02-12	15	32	2	2,0	35	17,0	M16	24	21600	5	XOLX 1204..	132
GHFC.35.R.03-12	18	35	3	2,0	35	17,0	M16	24	21360	5	XOLX 1204..	035
GHFC.42.R.04-12	25	42	4	2,0	35	17,0	M16	24	20800	5	XOLX 1204..	04204

MaxiMill – HFC high-feed end mill

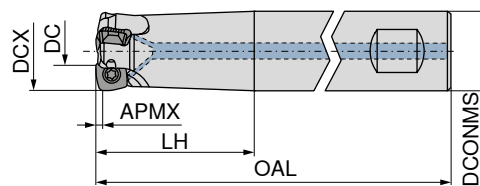
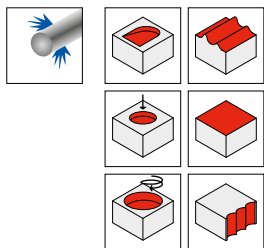

50 681 ...

50 681 ...

Designation	DC mm	DCX mm	ZNF	APMX mm	OAL mm	LH mm	DCONMS _{ns} mm	RPMX 1/min.	torque moment Nm	Insert		
CHFC.16.R.02-06-B-40	7,0	16	2	0,8	89	40	16	17300	1,2	XPLX 0603..		616
CHFC.16.R.02-06-A-40-200	7,0	16	2	0,8	200	40	16	4600	1,2	XPLX 0603..	716	
CHFC.20.R.03-06-B-50	11,0	20	3	0,8	101	50	20	14500	1,2	XPLX 0603..		620
CHFC.20.R.03-06-A-50-225	11,0	20	3	0,8	225	50	20	4200	1,2	XPLX 0603..	720	
CHFC.25.R.04-06-B-50	16,0	25	4	0,8	107	50	25	15600	1,2	XPLX 0603..		625
CHFC.25.R.04-06-A-50-225	16,0	25	4	0,8	225	50	25	4600	1,2	XPLX 0603..	725	
CHFC.32.R.05-06-B-25-60	23,0	32	5	0,8	117	60	25	11000	1,2	XPLX 0603..		632
CHFC.32.R.05-06-A-25-60-225	23,0	32	5	0,8	225	60	25	3900	1,2	XPLX 0603..	732	
CHFC.25.R.02-09-A-50-225	12,3	25	2	1,0	225	50	25	9000	3,2	XDLX 09T3..	025	
CHFC.25.R.03-09-A-50-225	12,3	25	3	1,0	225	50	25	9000	3,2	XDLX 09T3..	125	
CHFC.32.R.03-09-A-63-250	19,3	32	3	1,0	250	63	32	8100	3,2	XDLX 09T3..	032	
CHFC.32.R.02-12-A-63-250	14,8	32	2	2,0	250	63	32	6480	5	XOLX 1204..	132	
CHFC.35.R.03-12-A-63-250	17,8	35	3	2,0	250	63	32	6480	5	XOLX 1204..	035	

MaxiMill – HFC high-feed face mill

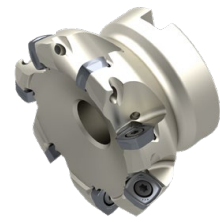
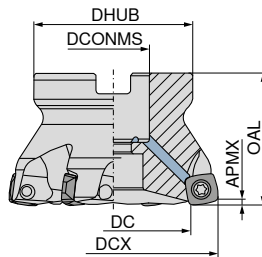
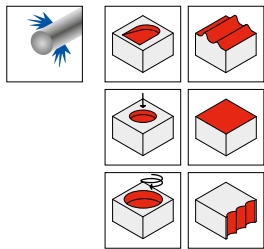

50 683 ...

Designation	DC mm	DCX mm	ZNF	APMX mm	OAL mm	DCONMS _{H6} mm	DHUB mm	RPMX 1/min.	torque moment Nm	Insert	
AHFC.32.R.03-09	19,3	32	3	1,0	40	16	38	27700	3,2	XDLX 09T3..	032
AHFC.35.R.04-09	19,3	35	4	1,0	40	16	38	26700	3,2	XDLX 09T3..	035
AHFC.40.R.04-09	27,3	40	4	1,0	40	16	38	26400	3,2	XDLX 09T3..	140
AHFC.42.R.05-09	29,3	42	5	1,0	40	16	38	26100	3,2	XDLX 09T3..	142
AHFC.50.R.05-09	37,3	50	5	1,0	40	22	43	23500	3,2	XDLX 09T3..	150
AHFC.52.R.06-09	39,3	52	6	1,0	40	22	43	23000	3,2	XDLX 09T3..	152
AHFC.63.R.06-09	50,3	63	6	1,0	40	22	48	20500	3,2	XDLX 09T3..	163
AHFC.66.R.07-09	53,3	66	7	1,0	40	22	48	20000	3,2	XDLX 09T3..	16600
AHFC.40.R.03-12	22,8	40	3	2,0	40	16	38	21120	5	XOLX 1204..	040
AHFC.42.R.04-12	24,8	42	4	2,0	40	16	38	20880	5	XOLX 1204..	042
AHFC.50.R.04-12	32,8	50	4	2,0	40	22	43	18800	5	XOLX 1204..	050
AHFC.52.R.05-12	34,8	52	5	2,0	40	22	43	18400	5	XOLX 1204..	052
AHFC.63.R.05-12	45,8	63	5	2,0	40	22	48	16400	5	XOLX 1204..	063
AHFC.66.R.06-12	48,8	66	6	2,0	40	22	48	16000	5	XOLX 1204..	066
AHFC.80.R.07-12	62,8	80	7	2,0	50	27	58	14000	5	XOLX 1204..	080
AHFC.100.R.08-12	82,8	100	8	2,0	50	32	78	12000	5	XOLX 1204..	100
AHFC.63.R.05-19	36,7	63	5	3,3	40	22	48	5500	5	XOLX 1906..	263
AHFC.80.R.06-19	53,7	80	6	3,3	50	27	58	4700	5	XOLX 1906..	280
AHFC.100.R.08-19	73,7	100	8	3,3	52	32	78	4100	5	XOLX 1906..	300
AHFC.125.R.10-19	98,7	125	10	3,3	63	40	88	3600	5	XOLX 1906..	325
AHFC.160.R.11-19	133,7	160	11	3,3	63	40	98	3100	5	XOLX 1906..	360 ¹⁾

1) With threaded holes M12 on the front face, pitch circle diameter = 66.7 mm / Without Through Coolant

Spare parts							
	80 950 ...	80 397 ...	80 950 ...	70 950 ...	70 950 ...	70 950 ...	80 950 ...
Insert							
XDLX 09T3..	036		113			303	110
XDLX 09T3.. (Ø32 – Ø42)	036	040	113	151		303	304
XOLX 1204..	037		114			303	01200
XOLX 1204.. (Ø40 – Ø42)	037	040	114	151		303	01200
XOLX 1906..	037		114			303	302
XPLX 0603..	033		110			303	116

XPLX / XDLX / XOLX / XOHX

Designation	IC mm	D1 mm	L mm	BS mm	S mm	AN °
XPLX 0603..	6,35	2,8	6	1	2,75	11
XDLX 09T3..	9,52	4,4	9	1,9	3,97	15
XO.X 1204..	12,70	5,5	12	1,3	4,76	10
XOLX 1906..	19,14	6,0	19	-	6,35	10

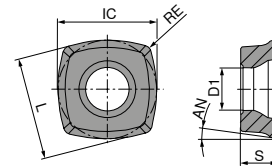

XPLX

ISO	RE mm	51 019 ...	51 019 ...	51 019 ...	51 019 ...	51 019 ...	51 116 ...	51 116 ...
060305ER	0,5						455	90501
060305SR	0,5	255	055	105	205	405		
P		●	●	●	●	○	●	●
M					○	●	●	●
K					○			
N								
S								○
H								
O								

-M50
CTCP220
DRAGONSKIN



XPLX
51 019 ...

-M50
CTPP225
DRAGONSKIN



XPLX
51 019 ...

-M50
CTPP235
DRAGONSKIN



XPLX
51 019 ...

-M50
CTPM225
DRAGONSKIN



XPLX
51 019 ...

-M50
CTPM240
DRAGONSKIN



XPLX
51 019 ...

-F40
CTPM245
DRAGONSKIN



XPLX
51 116 ...

-F40
CTCM245
DRAGONSKIN



XPLX
51 116 ...

XPLX

ISO	RE mm	51 019 ...	50 518 ...	51 116 ...
060305ER	0,5			
060305SR	0,5	505	558	55500
P				
M				
K				●
N				
S				●
H				●
O				

-M50
CTCK215
DRAGONSKIN



XPLX
51 019 ...

-F40
CTC5240
DRAGONSKIN



XPLX
50 518 ...

-F40
CTCS245
DRAGONSKIN



XPLX
51 116 ...

XDLX

ISO	RE mm				
09T308SR	0,8				
P			•	•	•
M					○
K					○
N					
S					
H					
O					



Insert	Material	RE
-M50 CTCP220 DRAGONSKIN	XDLX	258
-M50 CTPP225 DRAGONSKIN	XDLX	058
-M50 CTCP230 DRAGONSKIN	XDLX	008
-M50 CTPP235 DRAGONSKIN	XDLX	108

XDLX

ISO	RE mm					
09T308ER	0,8					
09T308SR	0,8					
P		•	•	○	•	•
M		•	•	•	•	•
K						
N						
S						○
H						
O						

Insert	Material	RE
-M50 CTPM225 DRAGONSKIN	XDLX	208
-M50 CTCM235 DRAGONSKIN	XDLX	308
-M50 CTPM240 DRAGONSKIN	XDLX	408
-F40 CTPM245 DRAGONSKIN	XDLX	458
-M50 CTPM245 DRAGONSKIN	XDLX	458
-M50 CTCM245 DRAGONSKIN	XDLX	90801



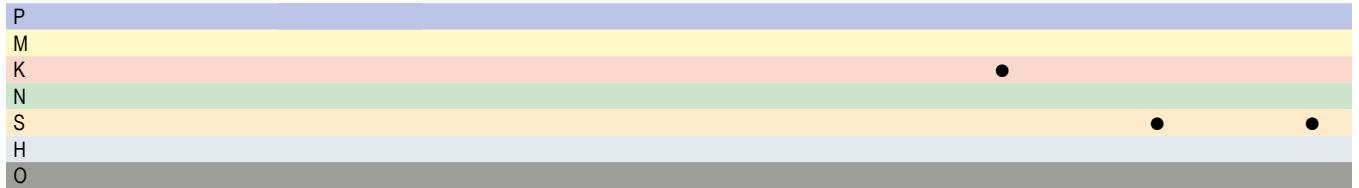

XDLX

-M50 CTCK215	-F40 CTC5240	-F40 CTCS245
DRAGONSKIN	DRAGONSKIN	DRAGONSKIN
		
XDLX	XDLX	XDLX
51 016 ...	50 503 ...	51 115 ...
508	558	558

ISO	RE mm
09T308ER	0,8
09T308SR	0,8









XOLX

-M50 CTCP220	-M50 CTPP225	-M50 CTCP230	-M50 CTPP235	-R50 CTPP235
DRAGONSKIN	DRAGONSKIN	DRAGONSKIN	DRAGONSKIN	DRAGONSKIN
				
XOLX	XOLX	XOLX	XOLX	XOLX
51 017 ...	51 017 ...	51 017 ...	51 017 ...	51 018 ...
260	060	010	110	110





ISO	RE mm
120410SR	1,0

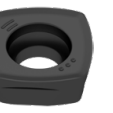

XOLX





ISO		RE	-M50 CTPM225		-M50 CTCM235		-M50 CTPM240		-F40 CTPM245		-M50 CTPM245		-F40 CTCM245		-M50 CTCM245	
		mm	DRAGONSKIN		DRAGONSKIN		DRAGONSKIN		DRAGONSKIN		DRAGONSKIN		DRAGONSKIN		DRAGONSKIN	
																
			XOLX		XOLX		XOLX		XOLX		XOLX		XOLX		XOLX	
			51 017 ...		51 017 ...		51 017 ...		51 022 ...		51 017 ...		51 022 ...		51 017 ...	
120410ER	1,0								460				91001			
120410SR	1,0		210		310		410		460				91001		91001	
P			●		●		○		●		●		●		●	
M			●		●		●		●		●		●		●	
K																
N																
S													○		○	
H																
O																

XOLX / XOHX

ISO		RE	-M50 CTCK215		-F40 CTC5240		-F50 CTC5240		-F40 CTC5245		-F50 CTC5245	
		mm	DRAGONSKIN		DRAGONSKIN		DRAGONSKIN		DRAGONSKIN		DRAGONSKIN	
												
			XOLX		XOLX		XOHX		XOLX		XOHX	
			51 017 ...		50 504 ...		51 124 ...		51 022 ...		51 124 ...	
120410ER	1,0				558				560			
120410SR	1,0		510		558		16000		560		56000	
P												
M												
K					●							
N												
S							●		●		●	
H												
O												

XOLX





ISO	RE mm				
190615ER	1,5				
190615SR	1,5				

	-M50 CTCP230	-M50 CTPP235	-M50 CTPM240	-F40 CTPM245
	DRAGONSKIN	DRAGONSKIN	DRAGONSKIN	DRAGONSKIN
				
	XOLX	XOLX	XOLX	XOLX
	51 017 ...	51 017 ...	51 017 ...	51 022 ...
	015	115	415	465

P	●	●	○	●
M		○	●	●
K	○	○		
N				
S				
H				
O				

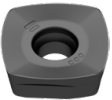
XOLX

ISO	RE mm				
190615ER	1,5				
190615SR	1,5				

	-F40 CTCM245	-M50 CTCK215	-M50 CTPK220	-F40 CTC5240	-F40 CTCS245
	DRAGONSKIN	DRAGONSKIN	DRAGONSKIN	DRAGONSKIN	DRAGONSKIN
					
	XOLX	XOLX	XOLX	XOLX	XOLX
	51 022 ...	51 017 ...	51 017 ...	50 504 ...	51 022 ...
	91501	515	61500	515	56500

P	●				
M	●				
K		●	●		
N					
S	○			●	●
H					
O					

Milling guide

Cutting data standard values	→ 145–148	Machining strategy	→ 176–179
Starting Parameter	→ 176–179	Technical Information	→ 193–198
Chip groove description and overview	→ 199–201	Grade description and overview	→ 202–208

MaxiMill – DHFC high-feed screw-in cutter

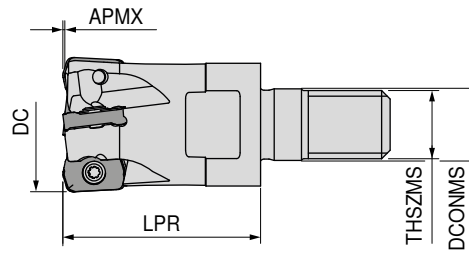
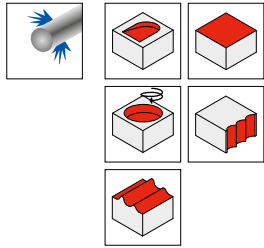

56 411 ...

Designation	DC mm	ZNF	APMX mm	LPR mm	DCONMS mm	THSZMS	torque moment Nm	Insert	
GDHFC.16.R.02-09	16	2	0,75	29	8,5	M8	0,65	LNKX 0925..	01602
GDHFC.16.R.03-09	16	3	0,75	29	8,5	M8	0,65	LNKX 0925..	01603
GDHFC.20.R.04-09	20	4	0,75	29	10,5	M10	0,65	LNKX 0925..	02004
GDHFC.25.R.05-09	25	5	0,75	33	12,5	M12	0,65	LNKX 0925..	02505
GDHFC.32.R.05-09	32	5	0,75	42	17,0	M16	0,65	LNKX 0925..	03205
GDHFC.35.R.06-09	35	6	0,75	42	17,0	M16	0,65	LNKX 0925..	03506
GDHFC.42.R.06-09	42	6	0,75	42	17,0	M16	0,65	LNKX 0925..	04206

MaxiMill – DHFC high-feed end mill

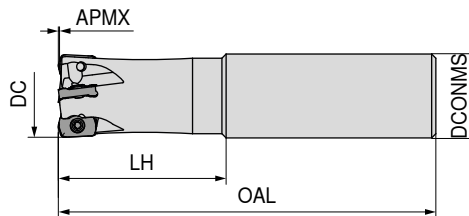
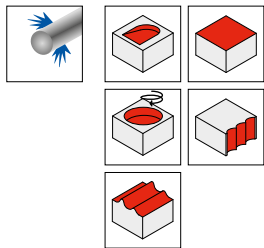





56 417 ...

Designation	DC mm	ZNF	APMX mm	OAL mm	LH mm	DCONMS ₁₆ mm	torque moment Nm	Insert	
CDHFC.16.R.05-09-A-32	16	3	0,75	80	32	16	0,65	LNKX 0925..	01603
CDHFC.20.R.04-09-A-40	20	4	0,75	90	40	20	0,65	LNKX 0925..	02004

Spare parts

DC

16 - 42

 TORX® blade 80 950 ...	 Key D 80 950 ...	 Molykote 70 950 ...	 Clamping screw 56 950 ...	 Torque screwdriver 80 950 ...
051	117	303	15000	191

LNKX

Designation	L mm	S mm
LNKX 0925..	9	2,50

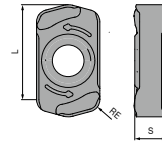

LNKX

	-R50 CTPP231	-M50 CTPP236	-R50 CTPP236	-M50 CTPM241	-R50 CTPK221	
	LNKX 56 353 ...	LNKX 56 355 ...	LNKX 56 353 ...	LNKX 56 355 ...	LNKX 56 353 ...	
ISO						
RE mm						
0925ZSR	1	12000	02500	02000	42500	27000

P	●	●	●	○	○
M	○	○	○	●	○
K	○	○	○	○	●
N					
S				○	
H					
O					

Milling guide

Cutting data standard values	→ 145-148	Machining strategy	→ 180
Technical Information	→ 193-198	Chip groove description and overview	→ 199-201
Grade description and overview	→ 202-208		

MaxiMill – 251 RS Screw in cutter

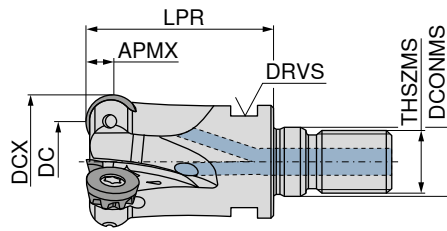
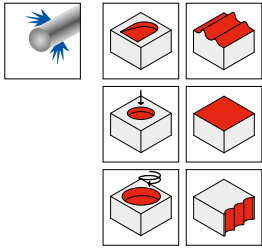

50 684 ...

Designation	DC mm	DCX mm	ZNF	APMX mm	DCONMS mm	LPR mm	THSZMS	DRVS mm	RPMX 1/min.	torque moment Nm	Insert	
G251.20.R.05-05-RS	15	20	5	2,5	10,5	33	M10	15	31800	0,7	RDHX 0501..	220
G251.25.R.06-05-RS	20	25	6	2,5	12,5	35	M12	17	24450	0,7	RDHX 0501..	225
G251.32.R.07-05-RS	27	32	7	2,5	17,0	35	M16	24	19850	0,7	RDHX 0501..	232
G251.20.R.03-08-RS	12	20	3	4,0	10,5	33	M10	15	25000	1,2	RDHX 0802..	120
G251.25.R.04-08-RS	17	25	4	4,0	12,5	35	M12	17	19000	1,2	RDHX 0802..	125
G251.32.R.05-08-35-RS	24	32	5	4,0	17,0	35	M16	24	19000	1,2	RDHX 0802..	132
G251.20.R.02-10-RS	10	20	2	5,0	10,5	33	M10	15	30000	2	RP.X 10T3..	020
G251.25.R.03-10-RS	15	25	3	5,0	12,5	35	M12	17	30000	2	RP.X 10T3..	025
G251.32.R.04-10-RS	22	32	4	5,0	17,0	35	M16	24	25000	2	RP.X 10T3..	032
G251.25.R.02-12-35-RS	13	25	2	6,0	12,5	35	M12	17	25000	3,2	RP.X 1204..	525
G251.32.R.03-12-35-RS	20	32	3	6,0	17,0	35	M16	24	19850	3,2	RP.X 1204..	532
G251.35.R.03-12-35-RS	23	35	3	6,0	17,0	35	M16	24	15900	3,2	RP.X 1204..	535
G251.42.R.04-12-42-RS	30	42	4	6,0	17,0	42	M16	24	15000	3,2	RP.X 1204..	542

	TORX® blade	Key D	Molykote	Clamping screw	Torque screwdriver
	80 950 ...	80 950 ...	70 950 ...	70 950 ...	80 950 ...
Spare parts					
Insert					
RDHX 0501..	031	108	303	149	191
RDHX 0802..	033	110	303	116	191
RP.X 10T3..	035	112	303	840	192
RP.X 1204..	036	113	303	304	192

MaxiMill – 251 RS End milling cutter

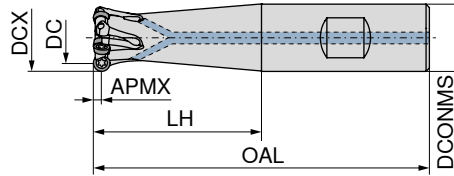
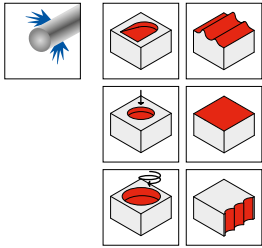





Designation	DC mm	DCX mm	ZNF	APMX mm	OAL mm	LH mm	DCONMS mm	RPMX 1/min.	Insert	50 685 ...	
										50 685 ...	50 685 ...
C251.12.R-03-05-B-16-25-RS	7	12	3	2,5	75	25	16	40000	RDHX 0501..		012
C251.12.R-03-05-A-32-165-RS	7	12	3	2,5	165	32	12	16000	RDHX 0501..	112	316
C251.16.R-04-05-B-32-RS	11	16	4	2,5	81	32	16	40000	RDHX 0501..		620
C251.16.R-04-05-A-40-165-RS	11	16	4	2,5	165	40	16	18000	RDHX 0501..	016	
C251.20.R-05-05-B-40-RS	15	20	5	2,5	91	40	20	31800	RDHX 0501..		620
C251.20.R-05-05-A-50-165-RS	15	20	5	2,5	165	50	20	18000	RDHX 0501..	120	
C251.16.R-02-08-B-32-RS	8	16	2	4,0	81	32	16	40000	RDHX 0802..		116
C251.16.R-02-08-A-40-165-RS	8	16	2	4,0	165	40	16	18000	RDHX 0802..	216	
C251.20.R-03-08-B-40-RS	12	20	3	4,0	91	40	20	31800	RDHX 0802..		220
C251.20.R-03-08-A-60-RS	12	20	3	4,0	110	50	20	30000	RDHX 0802..	020	
C251.20.R-03-08-A-50-200-RS	12	20	3	4,0	200	50	20	25000	RDHX 0802..	320	
C251.25.R-04-08-B-50-RS	17	25	4	4,0	107	50	25	25500	RDHX 0802..		625
C251.25.R-04-08-A-60-RS	17	25	4	4,0	116	60	25	19000	RDHX 0802..	125	
C251.25.R-04-08-A-60-225-RS	17	25	4	4,0	225	60	25	18000	RDHX 0802..	225	
C251.20.R-02-10-A-50-RS	10	20	2	5,0	102	50	20	25000	RP.X 10T3..	420	
C251.20.R-02-10-A-50-200-RS	10	20	2	5,0	200	50	20	25000	RP.X 10T3..	520	
C251.25.R-03-10-A-60-RS	15	25	3	5,0	116	60	25	25000	RP.X 10T3..	025	
C251.25.R-03-10-B-60-RS	15	25	3	5,0	116	60	25	20000	RP.X 10T3..		325
C251.25.R-03-10-A-60-225-RS	15	25	3	5,0	225	60	25	18000	RP.X 10T3..	425	
C251.32.R-04-10-A-70-RS	22	32	4	5,0	130	70	32	25000	RP.X 10T3..	032	
C251.25.R-02-12-B-30-RS	13	25	2	6,0	86	30	25	25000	RP.X 1204..		525
C251.32.R-03-12-A-RS	20	32	3	6,0	100	40	32	19000	RP.X 1204..	232	
C251.32.R-03-12-B-40-RS	20	32	3	6,0	100	40	32	19000	RP.X 1204..		132

Spare parts

Insert

Insert	80 950 ...	80 950 ...	70 950 ...	70 950 ...	80 950 ...
RDHX 0501..	031	108	303	149	191
RDHX 0802..	033	110	303	116	191
RP.X 10T3..	035	112	303	840	192
RP.X 10T3..		112	303	840	
RP.X 1204..	036	113	303	304	192

				
TORX® blade	Key D	Molykote	Clamping screw	Torque screwdriver
80 950 ...	80 950 ...	70 950 ...	70 950 ...	80 950 ...

MaxiMill – 251 RS Shell mill

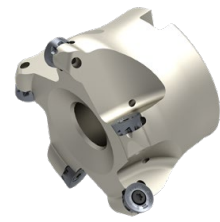
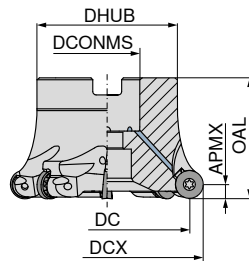
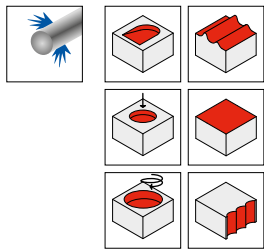

50 686 ...

Designation	DC mm	DCX mm	ZNF	APMX mm	OAL mm	DHUB mm	DCONMS _{H6} mm	RPMX 1/min.	torque moment Nm	Insert	
A251.40.R.03-10-RS	30	40	3	5	40	38	16	15900	2	RP.X 10T3..	240
A251.40.R.05-10-RS	30	40	5	5	40	38	16	16000	2	RP.X 10T3..	140
A251.42.R.06-10-RS	32	42	6	5	40	38	16	16000	2	RP.X 10T3..	142
A251.50.R.04-10-RS	40	50	4	5	40	43	22	12700	2	RP.X 10T3..	350
A251.50.R.06-10-RS	40	50	6	5	40	43	22	12500	2	RP.X 10T3..	150
A251.52.R.06-10-RS	42	52	6	5	40	43	22	12500	2	RP.X 10T3..	152
A251.40.R.04-12-RS	28	40	4	6	40	38	16	15900	3,2	RP.X 1204..	340
A251.50.R.04-12-RS	38	50	4	6	40	43	22	12700	3,2	RP.X 1204..	250
A251.50.R.05-12-RS	38	50	5	6	40	43	22	12500	3,2	RP.X 1204..	050
A251.52.R.05-12-RS	40	52	5	6	40	43	22	12500	3,2	RP.X 1204..	052
A251.63.R.06-12-RS	51	63	6	6	40	48	22	10000	3,2	RP.X 1204..	063
A251.66.R.07-12-RS	54	66	7	6	40	48	22	9000	3,2	RP.X 1204..	166
A251.80.R.05-12-RS	68	80	5	6	50	58	27	7950	3,2	RP.X 1204..	180
A251.80.R.07-12-RS	68	80	7	6	50	58	27	8000	3,2	RP.X 1204..	080
A251.100.R.06-12-RS	88	100	6	6	50	78	32	6350	3,2	RP.X 1204..	100
A251.100.R.10-12-RS	88	100	10	6	50	78	32	6350	3,2	RP.X 1204..	200
A251.50.R.04-16-RS	34	50	4	8	40	48	22	12700	5	RP.X 1605..	450
A251.52.R.04-16-RS	36	52	4	8	40	48	22	10100	5	RP.X 1605..	452
A251.63.R.05-16-RS	47	63	5	8	40	48	22	10100	5	RP.X 1605..	163
A251.66.R.05-16-RS	50	66	5	8	40	48	22	7950	5	RP.X 1605..	466
A251.80.R.06-16-RS	64	80	6	8	50	58	27	7950	5	RP.X 1605..	280
A251.100.R.07-16-RS	84	100	7	8	50	78	32	6350	5	RP.X 1605..	300
A251.125.R.08-16-RS	109	125	8	8	63	88	40	5050	5	RP.X 1605..	225
A251.80.R.05-20-RS	60	80	5	10	50	58	27	7950	5	RP.X 2006..	380
A251.100.R.06-20-RS	80	100	6	10	50	78	32	6350	5	RP.X 2006..	400
A251.125.R.06-20-RS	105	125	6	10	63	88	40	5050	5	RP.X 2006..	125

Spare parts

Insert

	TORX® blade	Clamping key – T	Key D	Power Screw	Molykote	Clamping screw	Torque screwdriver
RP.X 10T3..	035	040	112	151	303	840	192
RP.X 1204..	036	040	113	151	303	304	192
RP.X 1605..	037	050	114	154	303	01200	193
RP.X 2006..	037		114		303	302	193

RDHX / RPHX / RPNX

Designation	IC mm	D1 mm	S mm
RDHX 0501..	5	2,5	1,59
RDHX 0802..	8	2,8	2,38
RP.X 10T3..	10	3,4	3,97
RP.X 1204..	12	4,4	4,76
RP.X 1605..	16	5,5	5,56
RP.X 2006..	20	6,0	6,35

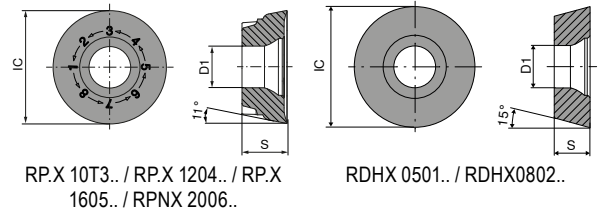

RDHX

ISO	-SN CTCP230 DRAGONSKIN		-SN CTPP235 DRAGONSKIN		-F50 CTPM240 DRAGONSKIN		-F50 CTPM245 DRAGONSKIN		-F50 CTCM245 DRAGONSKIN	
	RDHX 51 048 ...	RDHX 51 048 ...	RDHX 51 083 ...	RDHX 51 083 ...	RDHX 51 083 ...	RDHX 51 083 ...	RDHX 51 083 ...			
0501M0SN	020	120				465				
0802M0SN	025	125	420			470	92001			
0802M4SN						471	92101			
P	●	●	○	●	●	●	●			
M		○	●	●	●	●	●			
K	○	○								
N										
S							○			
H										
O										

RDHX

ISO	-FN H216T		-M31 CTC5240 DRAGONSKIN		-F50 CTCS245 DRAGONSKIN	
	RDHX 50 481 ...	RDHX 50 481 ...	RDHX 51 083 ...	RDHX 51 083 ...	RDHX 51 083 ...	RDHX 51 083 ...
0501M0FN		600				
0802M0EN				500		
0802M0FN		602				
0802M0SN						570
0802M4EN				50100		
P						
M						
K			○			
N			●			
S				●	●	●
H						
O			○			

RPHX / RPNX

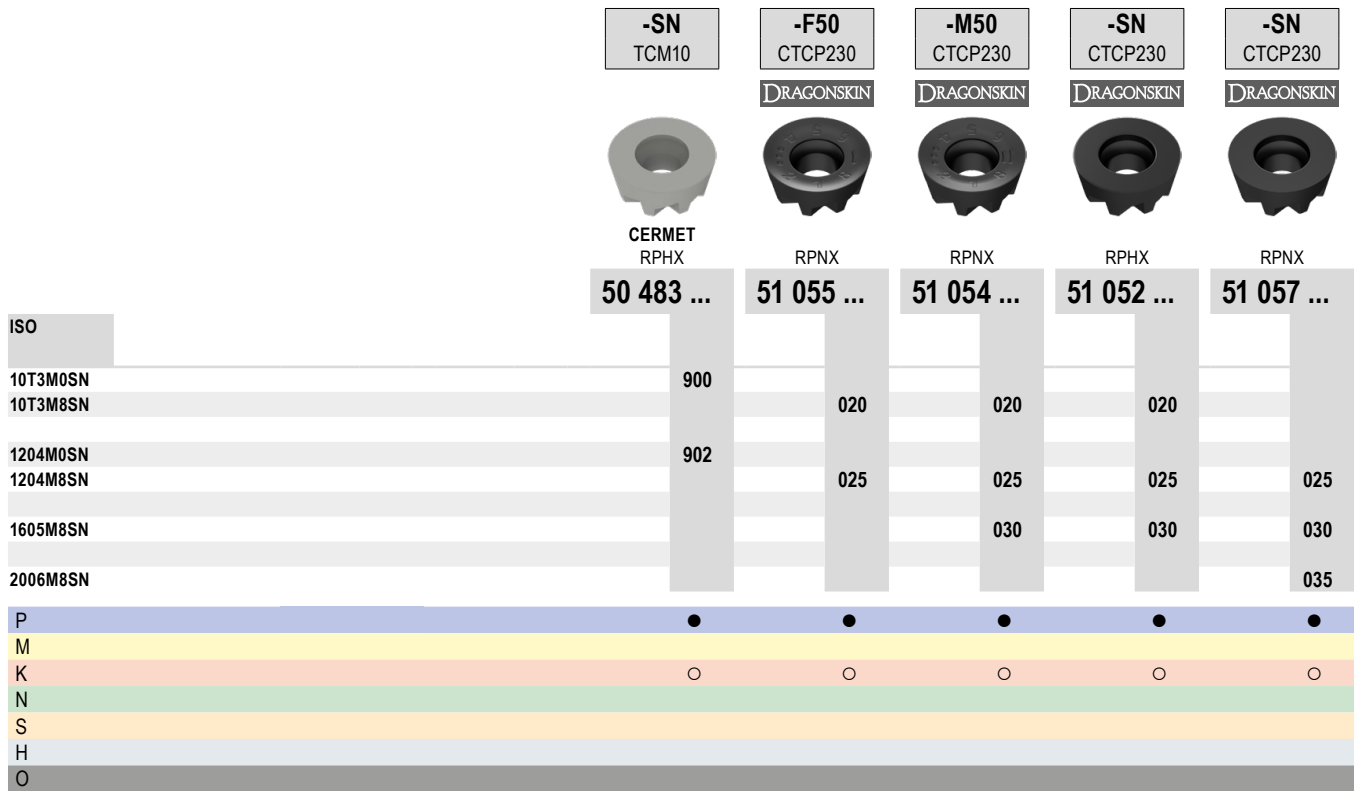

RPHX / RPNX

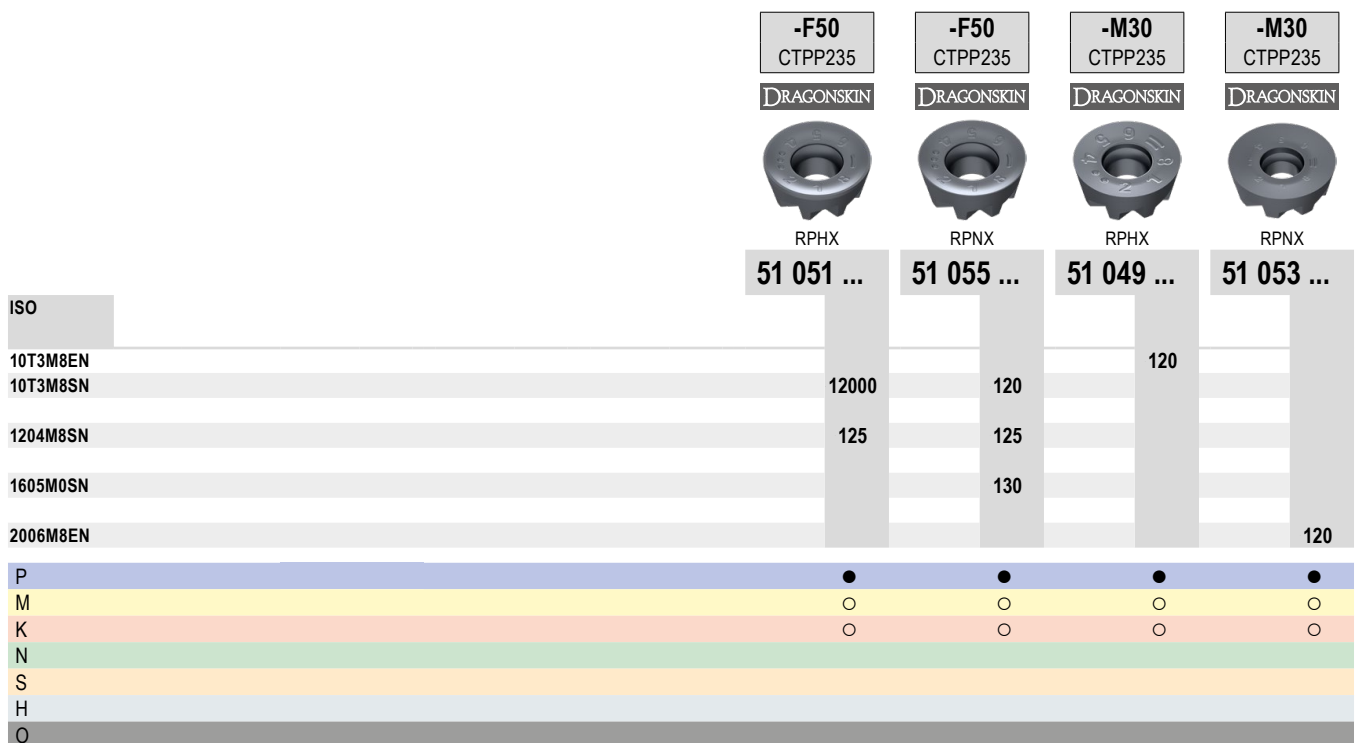

RPNX / RPHX

	-M50 CTPP235 DRAGONSKIN RPNX 51 054 ...	-M50 CTPP235 DRAGONSKIN RPHX 51 050 ...	-SN CTPP235 DRAGONSKIN RPHX 51 052 ...	-SN CTPP235 DRAGONSKIN RPNX 51 057 ...
ISO				
10T3M8SN	12000	12000	120	
1204M8SN	125		125	125
1605M8SN	130		130	130
2006M8SN				135
P	●	●	●	●
M	○	○	○	○
K	○	○	○	○
N				
S				
H				
O				

RPHX

	-F50 CTPM225 DRAGONSKIN RPHX 51 051 ...	-M30 CTPM225 DRAGONSKIN RPHX 51 049 ...	-SN CTPM225 DRAGONSKIN RPHX 51 052 ...	-F50 CTCM235 DRAGONSKIN RPHX 51 051 ...	-M30 CTCM235 DRAGONSKIN RPHX 51 049 ...
ISO					
1204M8EN		225			325
1204M8SN	225		225	325	
P	●	●	●	●	●
M	●	●	●	●	●
K					
N					
S					
H					
O					

RPHX / RPNX

	-F50 CTPM240 DRAGONSKIN RPHX 51 051 ...	-F50 CTPM240 DRAGONSKIN RPNX 51 055 ...	-M30 CTPM240 DRAGONSKIN RPHX 51 049 ...	-M30 CTPM240 DRAGONSKIN RPNX 51 053 ...	-M50 CTPM240 DRAGONSKIN RPHX 51 050 ...
ISO					
10T3M8EN			420		420
10T3M8SN	420				420
1204M8EN			425		425
1204M8SN	425				425
1605M8EN			430		
1605M8SN	430				
2006M8EN				420	
2006M8SN		435			
P	○	○	○	○	○
M	●	●	●	●	●
K					
N					
S					
H					
O					

RPHX / RPNX

	CTPM245 DRAGONSKIN RPHX 51 052 ...	-F50 CTPM245 DRAGONSKIN RPHX 51 051 ...	-F50 CTPM245 DRAGONSKIN RPNX 51 055 ...	-M32 CTPM245 DRAGONSKIN RPHX 51 108 ...	-M50 CTPM245 DRAGONSKIN RPHX 51 050 ...
ISO					
10T3M4SN		470 ¹⁾	470 ¹⁾		470 ¹⁾
10T3M8SN		471	471		471
1204M4EN	475 ¹⁾			475 ¹⁾	
1204M4SN		475 ¹⁾	475 ¹⁾		475 ¹⁾
1204M6SN		476			476
1204M8SN		477	476		477
1605M8SN		480			
2006M4SN		485 ¹⁾			
2006M8SN			485		
P	●	●	●	●	●
M	●	●	●	●	●
K					
N					
S					
H					
O					

1) Insert with 4 indexes

RPNX / RPHX

	-F50 CTCM245 DRAGONSKIN RPNX 51 055 ...	-M50 CTCM245 DRAGONSKIN RPNX 51 054 ...	-F50 CTCM245 DRAGONSKIN RPHX 51 051 ...	-M50 CTCM245 DRAGONSKIN RPHX 51 050 ...
ISO				
10T3M4SN	92001 ¹⁾		92001 ¹⁾	92001 ¹⁾
10T3M8SN	92101		92101	
1204M4SN	92501 ¹⁾		92501 ¹⁾	92501 ¹⁾
1204M6SN		92601	92601	92601
1204M8SN	92601			92701
1605M8SN	93001		93001	
2006M8SN	93501	93501		
P	•	•	•	•
M	•	•	•	•
K				
N				
S	○	○	○	○
H				
O				

1) Insert with 4 indexes

RPHX / RPNX

	-SN CTCK215 DRAGONSKIN RPHX 51 052 ...	-SN CTCK215 DRAGONSKIN RPNX 51 057 ...	-SN CTPK220 DRAGONSKIN RPNX 51 057 ...	NEW -F10 CTPX715 DRAGONSKIN RPHX 51 156 ...	-27P H216T RPHX 50 483 ...
ISO					
10T3M8FN				02002	600
10T3M8SN	520		620		
1204M8FN				02502	602
1204M8SN	525	525	625		
1605M8FN				03002	604
1605M8SN	530	530	630		
2006M8SN		535	635		
P				○	
M				○	
K	•	•	•	•	○
N				•	•
S				○	
H					
O				○	○

RPNX / RPHX

	-M31 CTC5240 DRAGONSKIN RPNX 51 149 ...	-M31 CTC5240 DRAGONSKIN RPHX 50 493 ...	-F50 CTCS245 DRAGONSKIN RPHX 51 051 ...	-F50 CTCS245 DRAGONSKIN RPNX 51 055 ...	-R60 CTP6215 RPNX 50 508 ...
ISO					
10T3M4EN		550 ¹⁾			
10T3M4SN			570 ¹⁾		
10T3M8EN		551		571	
10T3M8SN					
1204M4EN		552 ¹⁾			
1204M4SN			575		
1204M6EN		56200			
1204M6SN			57800		
1204M8EN		582			300
1204M8SN			577		
1605M8EN		555	58100		
2006M8EN	12001				
2006M8SN				585	
P					
M					
K					
N					
S	•	•	•	•	•
H					
O					

1) Insert with 4 indexes

Milling guide

Cutting data standard values	→ 145-148	Machining strategy	→ 181
Technical Information	→ 193-198	Chip groove description and overview	→ 199-201
Grade description and overview	→ 202-208		

R 1000 screw-in button insert milling cutter

▲ Insert angle 0°

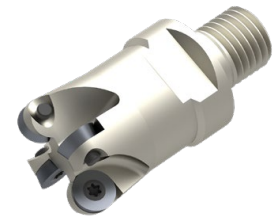
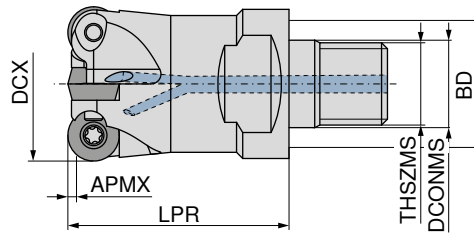
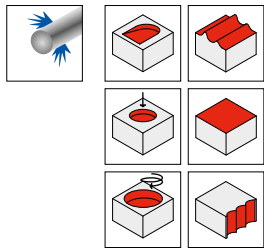

56 403 ...

Designation	DCX mm	ZNF	APMX mm	THSZMS	LPR mm	DCONMS mm	BD mm	torque moment Nm	Insert	
R1000G.15.2.M8-07.IK	15	2	1,5	M8	28,5	8,5	13,8	0,9	RD.X 0702..	153
R1000G.16.3.M8-07.IK	16	3	1,5	M8	28,5	8,5	13,8	0,9	RD.X 0702..	161
R1000G.20.4.M10-07.IK	20	4	1,5	M10	28,5	10,5	18,0	0,9	RD.X 0702..	203
R1000G.25.5.M12-07.IK	25	5	1,5	M12	28,5	12,5	21,0	0,9	RD.X 0702..	252
R1000G.30.5.M16-07.IK	30	5	1,5	M16	28,5	17,0	29,0	0,9	RD.X 0702..	301
R1000G.35.6.M16-07.IK	35	6	1,5	M16	28,5	17,0	29,0	0,9	RD.X 0702..	351
R1000G.42.7.M16-07.IK	42	7	1,5	M16	42,5	17,0	29,0	0,9	RD.X 0702..	421
R1000G.20.2.M10-10.IK	20	2	2,8	M10	29,0	10,5	18,0	2,4	RD.X 1003..	204
R1000G.25.2.M12-10.IK	25	2	2,8	M12	33,0	12,5	21,0	2,4	RD.X 1003..	253
R1000G.25.3.M12-10.IK	25	3	2,8	M12	33,0	12,5	21,0	2,4	RD.X 1003..	254
R1000G.30.4.M12-10.IK	30	4	2,3	M12	33,0	12,5	21,0	2,4	RD.X 1003..	302
R1000G.30.4.M16-10.IK	30	4	2,8	M16	43,0	17,0	23,0	2,4	RD.X 1003..	303
R1000G.35.5.M16-10.IK	35	5	2,8	M16	43,0	17,0	29,0	2,4	RD.X 1003..	352
R1000G.42.5.M16-10.IK	42	5	2,8	M16	43,0	17,0	29,0	2,4	RD.X 1003..	422
R1000G.42.6.M16-10.IK	42	6	2,8	M16	43,0	17,0	29,0	2,4	RD.X 1003..	423
R1000G.24.2.M12-12.IK	24	2	3,0	M12	33,0	12,5	21,0	2,4	RD.X 12T3..	241
R1000G.35.3.M16-12.IK	35	3	3,0	M16	43,0	17,0	29,0	2,4	RD.X 12T3..	353
R1000G.35.4.M16-12.IK	35	4	3,0	M16	43,0	17,0	29,0	2,4	RD.X 12T3..	354
R1000G.42.4.M16-12.IK	42	4	3,0	M16	43,0	17,0	29,0	2,4	RD.X 12T3..	424
R1000G.42.5.M16-12.IK	42	5	3,0	M16	43,0	17,0	29,0	2,4	RD.X 12T3..	425
R1000G.32.2.M16-16.IK	32	2	4,0	M16	43,5	17,0	29,0	4,3	RD.X 1604..	321
R1000G.35.3.M16-16.IK	35	3	4,0	M16	43,5	17,0	29,0	4,3	RD.X 1604..	355

Spare parts

Insert

	80 950 ...	56 950 ...	56 950 ...	80 950 ...	70 950 ...	56 950 ...	80 950 ...
RD.X 0702..		032		109	303	006	191
RD.X 1003..		036		113	303	010	192
RD.X 12T3..		036	022	113	303	010	192
RD.X 1604..		037		114	303	012	192

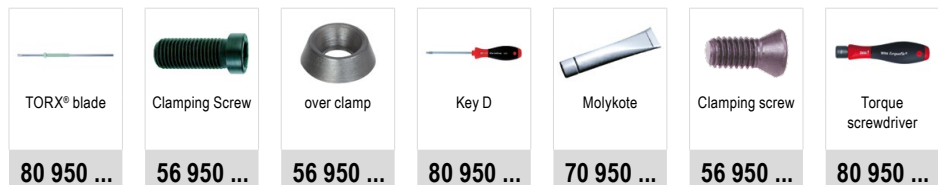

R 1007 screw-in button insert milling cutter

- ▲ Insert angle 7°
- ▲ for Steel < 10 % Cr

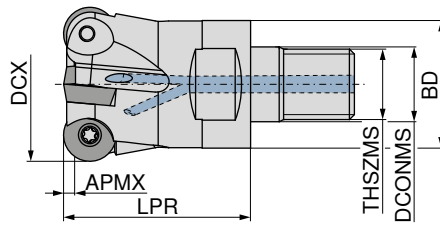
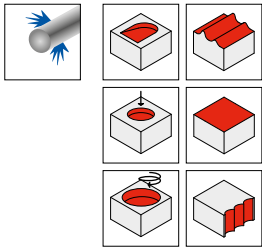







56 405 ...

Designation	DCX mm	ZNF	APMX mm	THSZMS	LPR mm	DCONMS mm	BD mm	torque moment Nm	Insert	
R1007G.25.3.M12-10.IK	25	3	2,5	M12	32,5	12,5	21	2,4	RD.X 1003..	251
R1007G.42.6.M16-10.IK	42	6	2,5	M16	42,5	17,0	29	2,4	RD.X 1003..	421
R1007G.35.4.M16-12.IK	35	4	3,0	M16	42,5	17,0	29	2,4	RD.X 12T3..	352

Spare parts

Insert

RD.X 1003..	036		113	303	010	192
RD.X 12T3..	036	022	113	303	010	192

 TORX® blade	 Clamping Screw	 Key D	 Molykote	 Clamping screw	 Torque screwdriver
80 950 ...	56 950 ...	80 950 ...	70 950 ...	56 950 ...	80 950 ...

R 1002 shank button insert milling cutter

▲ Insert angle 0°

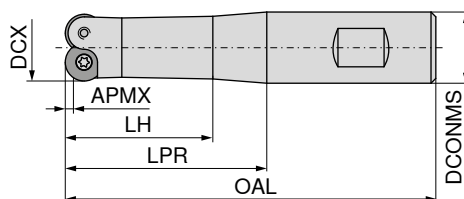
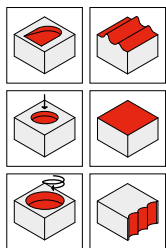

56 443 ...

Designation	DCX mm	ZNF	APMX mm	OAL mm	LPR mm	LH mm	DCONMS mm	Insert	
R1002C.15.2.40-07	15	2	2,6	89	40	23	16	RD.X 0702..	151
R1002C.15.2.60-07	15	2	2,6	109	60	23	16	RD.X 0702..	152
R1002C.15.2.80-07	15	2	2,6	131	80	22	20	RD.X 0702..	153
R1002C.15.2.100-07	15	2	2,6	151	100	22	20	RD.X 0702..	154
R1002C.20.2.40-10	20	2	4,0	91	40	23	20	RD.X 1003..	201
R1002C.20.2.60-10	20	2	4,0	111	60	23	20	RD.X 1003..	202
R1002C.20.2.80-10	20	2	4,0	137	80	23	25	RD.X 1003..	203
R1002C.20.2.100-10	20	2	4,0	157	100	23	25	RD.X 1003..	204
R1002C.20.2.120-10	20	2	4,0	177	125	23	25	RD.X 1003..	205

R 1000 shell button insert milling cutter

▲ Insert angle 0°

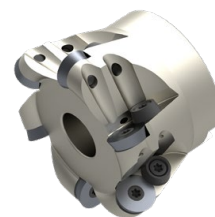
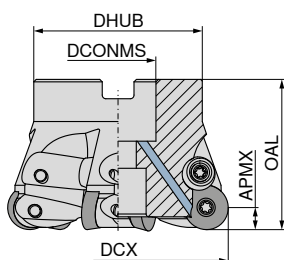
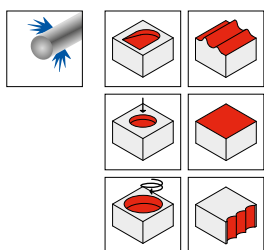







56 407 ...

Designation	DCX mm	ZNF	APMX mm	OAL mm	DCONMS mm	DHUB mm	torque moment Nm	Insert	
R1000A.42.6.43-10.IK	42	6	2,8	43,0	16	35	2,4	RD.X 1003..	420
R1000A.42.4.43-12.IK	42	4	3,0	43,0	16	35	2,4	RD.X 12T3..	421
R1000A.42.5.43-12.IK	42	5	3,0	43,0	16	35	2,4	RD.X 12T3..	422
R1000A.52.5.53-12.IK	52	5	3,5	53,0	22	40	2,4	RD.X 12T3..	521
R1000A.52.4.53,5-16.IK	52	4	4,7	53,5	22	40	4,3	RD.X 1604..	522
R1000A.66.5.53,5-16.IK	66	5	5,1	53,5	27	48	4,3	RD.X 1604..	661
R1000A.80.6.53,5-16.IK	80	6	5,8	53,5	27	60	4,3	RD.X 1604..	801

Spare parts

Insert

RD.X 1003..	036			113	303	010	192
RD.X 12T3..	036	022		113	303	010	192
RD.X 1604..	037		210	114	303	012	192

 TORX® blade	 Clamping Screw	 over clamp	 Key D	 Molykote	 Clamping screw	 Torque screwdriver
80 950 ...	56 950 ...	56 950 ...	80 950 ...	70 950 ...	56 950 ...	80 950 ...

R 1007 shell button insert milling cutter

▲ Insert angle 7°

▲ for Steel < 10 % Cr + Milling machines with low power

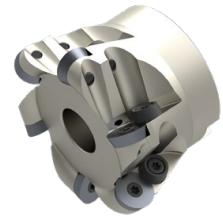
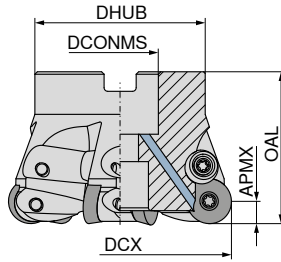
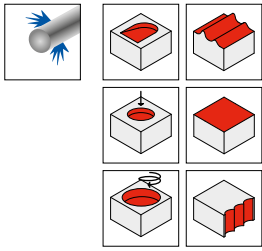

56 409 ...

Designation	DCX mm	ZNF	APMX mm	OAL mm	DCONMS mm	DHUB mm	torque moment Nm	Insert	
R1007A.42.6.42,5-10.IK	42	6	3,5	42,5	16	35	2,4	RD.X 1003..	421
R1007A.52.7.52,5-10.IK	52	7	3,5	52,5	22	40	2,4	RD.X 1003..	521
R1007A.52.5.52,5-12.IK	52	5	3,5	52,5	22	40	2,4	RD.X 12T3..	522
R1007A.66.6.52,5-12.IK	66	6	3,5	52,5	27	48	2,4	RD.X 12T3..	661
R1007A.80.7.54,5-12.IK	80	7	3,5	54,5	27	60	2,4	RD.X 12T3..	801
R1007A.52.5.53-16.IK	52	5	4,1	53,0	22	40	4,3	RD.X 1604..	523
R1007A.66.5.53-16.IK	66	5	4,6	53,0	27	48	4,3	RD.X 1604..	662
R1007A.66.6.53-16.IK	66	6	5,1	53,0	27	48	4,3	RD.X 1604..	663
R1007A.80.6.53-16.IK	80	6	5,1	53,0	27	60	4,3	RD.X 1604..	802
R1007A.100.7.53-16	100	7	5,1	53,0	32	70	4,3	RD.X 1604..	910 ¹⁾
R1007A.125.8.53-16	125	8	5,2	53,0	40	90	4,3	RD.X 1604..	925 ¹⁾
R1007A.160.9.53-16	160	9	5,1	53,0	40	120	4,3	RD.X 1604..	960 ¹⁾

1) Without Through Coolant

Spare parts	TORX® blade	Clamping Screw	over clamp	Key D	Molykote	Clamping screw	Torque screwdriver
Insert	80 950 ...	56 950 ...	56 950 ...	80 950 ...	70 950 ...	56 950 ...	80 950 ...
RD.X 1003..	036			113	303	010	192
RD.X 12T3..	036	022		113	303	010	192
RD.X 1604..	037		210	114	303	012	192

RDHX / RDMX / RDEX / RDPX

Designation	IC mm	S mm
RD.X 0702..	7	2,38
RD.X 1003..	10	3,18
RD.X 12T3..	12	3,97
RD.X 1604..	16	4,76

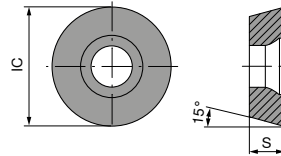

RDHX / RDMX / RDEX / RDPX

	WTN1205 RDHX	WAN1240 RDMX	WAX1240 RDEX	-HP WAN2225 RDPX	-F30P WUN4210 RDHX
	56 302 ...	56 309 ...	56 314 ...	56 348 ...	56 304 ...
ISO					
0702M0E					611
0702M0T	111		611		
1003M0S				231	
1003M0T	131	731	631		631
12T3M0S				241	
12T3M0T	141	741	641		641
1604M0S				251	
1604M0T	151	751	651		651
P	●	●	●		
M	●	○	○	●	
K	●	○	○		○
N					●
S				●	
H	●				
O					○

Milling guide

Cutting data standard values	→ 182-184	Machining strategy	→ 185+186
Technical Information	→ 193-198	Grade description	→ 199-201
Designation System	→ 202-208		

MaxiMill – 252 Shell mill

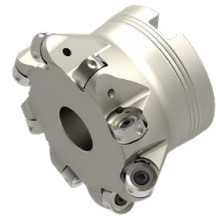
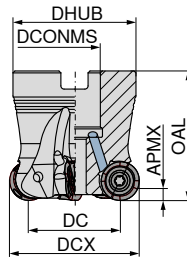
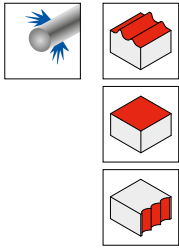







NEW

50 689 ...

Designation	DC mm	DCX mm	ZNF	APMX mm	OAL mm	DCONMS mm	DHUB mm	torque moment Nm	Insert	
A252.40.R.05-10	30	40	5	2,5	40	16	38	2	RNHU 1004..	140
A252.42.R.05-10	32	42	5	2,5	40	16	38	2	RNHU 1004..	142
A252.50.R.06-10	40	50	6	2,5	40	22	43	2	RNHU 1004..	150
A252.52.R.07-10	42	52	7	2,5	40	22	43	2	RNHU 1004..	152
A252.63.R.08-10	53	63	8	2,5	40	22	48	2	RNHU 1004..	16300
A252.80.R.10-10	70	80	10	2,5	50	27	58	2	RNHU 1004..	18000
A252.40.R.04-12	28	40	4	3,0	40	16	38	3,2	RNHU 1205..	240
A252.50.R.05-12	38	50	5	3,0	40	22	43	3,2	RNHU 1205..	250
A252.52.R.05-12	40	52	5	3,0	40	22	43	3,2	RNHU 1205..	252
A252.63.R.06-12	51	63	6	3,0	40	22	48	3,2	RNHU 1205..	263
A252.66.R.07-12	54	66	7	3,0	40	22	48	3,2	RNHU 1205..	266
A252.80.R.08-12	68	80	8	3,0	50	27	58	3,2	RNHU 1205..	280
A252.100.R.10-12	88	100	10	3,0	50	32	78	3,2	RNHU 1205..	30000
A252.125.R.12-12	113	125	12	3,0	63	40	88	3,2	RNHU 1205..	32500

Spare parts
Insert

	80 950 ...	80 397 ...	80 950 ...	70 950 ...	70 950 ...	70 950 ...	80 950 ...
RNHU 1004.. (Ø40 – Ø80)	053		127				192
RNHU 1205.. (Ø40)	054	040	128	151	303	710	192
RNHU 1205.. (Ø50 – Ø125)	054		128		303	839	192

						
TORX® blade	Clamping key – T	Key D	Power Screw	Molykote	Clamping screw	Torque screwdriver
80 950 ...	80 397 ...	80 950 ...	70 950 ...	70 950 ...	70 950 ...	80 950 ...

RNHU

Designation	IC mm	D1 mm	S mm
RNHU 1004..	10	3,4	4,60
RNHU 1205..	12	4,4	5,30

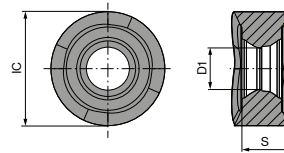

RNHU

	NEW -M50 CTPP235 DRAGONSKIN	NEW -F50 CTPM240 DRAGONSKIN	NEW -M31 CTPM245 DRAGONSKIN	NEW -M32 CTPM245 DRAGONSKIN	NEW -M31 CTC5240 DRAGONSKIN	NEW -M31 CTC5240 DRAGONSKIN
	RNHU	RNHU	RNHU	RNHU	RNHU	RNHU
	51 130 ...	51 129 ...	51 106 ...	51 107 ...	50 520 ...	50 521 ...
ISO						
1004M4ER	12000	42000	470	470	550	
1205M4ER		42500	475	475		552
1205M4SR	12500					
P	●	○	●	●		
M	○	●	●	●		
K	○					
N						
S					●	●
H						
O						

Milling guide

Cutting data standard values	→ 145-148	Machining strategy	→ 187
Technical Information	→ 193-198	Chip groove description and overview	→ 199-201
Grade description and overview	→ 202-208		

K 2000 / K 2001 shank copy milling cutter

▲ with carbide shank

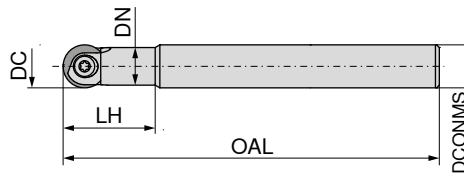
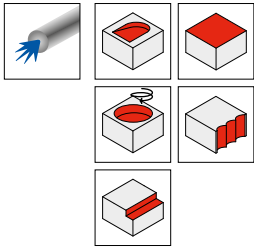



56 100 ...	56 101 ...
060 ¹⁾	
061 ¹⁾	
062 ¹⁾	
063 ¹⁾	
081 ¹⁾	
082 ¹⁾	
083 ¹⁾	
101 ¹⁾	
102 ¹⁾	
103 ¹⁾	
121 ¹⁾	121
122 ¹⁾	122
123 ¹⁾	123
	161
	162
	163
	201
	202
	203
	252
	253

ISO designation	DC mm	DN mm	LH mm	OAL mm	DCONMS mm	torque moment Nm
K2000C.6.16.100	6	5,3	16	100	8	0,5
K2000C.6.20.100	6	5,8	20	100	6	0,5
K2000C.6.70.150	6	5,8	70	150	6	0,5
K2000C.6.100.200	6	5,8	100	200	6	0,5
K2000C.8.25.80	8	7,0	25	80	8	1
K2000C.8.25.100	8	7,0	25	100	8	1
K2000C.8.40.150	8	7,0	40	150	8	1
K2000C.10.35.80	10	8,8	35	80	10	3
K2000C.10.35.120	10	8,8	35	120	10	3
K2000C.10.50.150	10	8,8	50	150	10	3
K2000C.12.35.80	12	10,5	35	80	12	4
K2001C.12.35.80	12	10,5	35	80	12	4
K2000C.12.35.120	12	10,5	35	120	12	4
K2001C.12.35.120	12	10,5	35	120	12	4
K2000C.12.50.160	12	10,5	50	160	12	4
K2001C.12.50.160	12	10,5	50	160	12	4
K2001C.16.40.100	16	14,0	40	100	16	5
K2001C.16.40.140	16	14,0	40	140	16	5
K2001C.16.55.175	16	14,0	55	175	16	5
K2001C.20.50.100	20	18,0	50	100	20	5
K2001C.20.50.140	20	18,0	50	140	20	5
K2001C.20.75.190	20	18,0	75	190	20	5
K2001C.25.60.160	25	22,4	60	160	25	8
K2001C.25.90.210	25	22,4	90	210	25	8

1) Without Through Coolant

Applicable inserts

	ROHX-FM3, ROHX-FM4, ROHX-FM6, ROHX-MR5, ROGX-MR4
---	---

	XOHX06..-MR2, XOHX-FM1
---	------------------------

K 2002 shank copy milling cutter

▲ cylindrical steel shank version

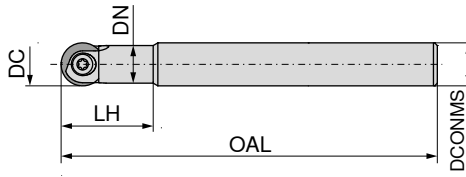
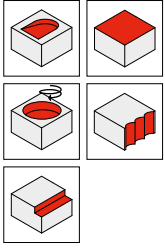

56 102 ...

Designation	DC mm	DN mm	LH mm	OAL mm	DCONMS mm	torque moment		
						Nm		
K2002C.12.32.90	12	10,5	32	90	12	4		121
K2002C.12.32.130	12	10,5	32	130	12	4		122
K2002C.12.46.150	12	10,5	46	150	12	4		123
K2002C.16.36.100	16	14,0	36	100	16	5		161
K2002C.16.36.140	16	14,0	36	140	16	5		162
K2002C.16.53.160	16	14,0	53	160	16	5		163
K2002C.20.45.160	20	18,0	45	160	20	5		202
K2002C.20.61.175	20	18,0	61	175	20	5		203
K2002C.25.45.160	25	22,4	45	160	25	8		252
K2002C.25.70.190	25	22,4	70	190	25	8		253
K2002C.32.56.175	32	28,6	56	175	32	8		322
K2002C.32.80.210	32	28,6	80	210	32	8		323

Applicable inserts

	ROHX-FM3, ROHX-FM4, ROHX-FM6, ROHX-MR5, ROGX-MR4
---	---

	XOHX-FM1
---	----------

K 2003 shank copy milling cutter

▲ tapered execution

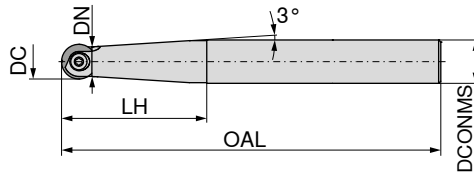
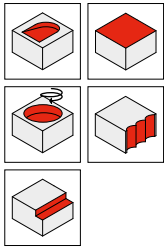

56 104 ...

Designation	DC mm	DN mm	LH mm	OAL mm	DCONMS mm	torque moment Nm	
K2003C.6.16.90	6	5,3	40	90	10	0,5	061
K2003C.8.50.85	8	7,5	50	85	12	1	081
K2003C.8.50.140	8	7,5	50	140	12	1	082
K2003C.10.35.85	10	9,0	35	85	12	3	101
K2003C.10.35.150	10	9,0	35	150	12	3	102
K2003C.12.60.110	12	10,5	60	110	16	4	121
K2003C.12.60.160	12	10,5	60	160	16	4	122
K2003C.16.67.120	16	14,0	67	120	20	5	161
K2003C.16.67.175	16	14,0	67	175	20	5	162
K2003C.20.80.190	20	18,0	80	190	25	5	201
K2003C.25.100.210	25	22,4	100	210	32	8	251
K2003C.32.123.240	32	28,6	123	240	40	8	321

Applicable inserts

	ROHX-FM3, ROHX-FM4, ROHX-FM6, ROHX-MR5, ROGX-MR4
---	---

	XOHX-FM1
---	----------

K 2000 screw-in copy milling cutter

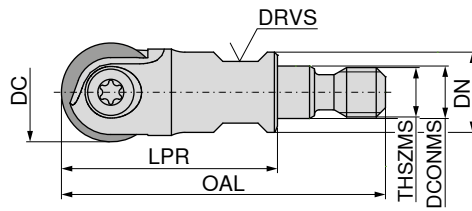
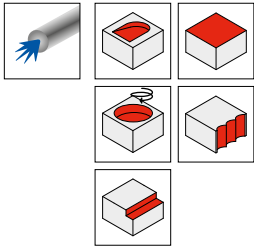



56 120 ...

Designation	DC mm	LPR mm	DN mm	OAL mm	DCONMS mm	THSZMS mm	DRVS mm	torque moment Nm	
K2000G.8.25.M6	8	25	10	39,5	6,5	M6	8	1	081 ¹⁾
K2000G.10.25.M6	10	25	10	39,5	6,5	M6	8	3	101 ¹⁾
K2000G.12.25.M6	12	25	10	39,5	6,5	M6	8	4	121 ¹⁾
K2000G.12.26.M8	12	26	13	43,5	8,5	M8	10	4	122
K2000G.16.26.M8	16	26	13	43,5	8,5	M8	10	5	161
K2000G.20.30.M10	20	30	18	49,5	10,5	M10	15	5	201
K2000G.25.40.M12	25	40	21	62,0	12,5	M12	17	8	251
K2000G.32.45.M16	32	45	30	69,0	17,0	M16	26	8	321

1) Without Through Coolant

Applicable inserts

	ROHX-FM3, ROHX-FM4, ROHX-FM6, ROHX-MR5, ROGX-MR4
---	---

	XOHX-FM1
---	----------

Spare parts

DC	TORX® blade 80 950 ...	Key D 80 950 ...	Molykote 70 950 ...	Clamping screw 56 950 ...	Torque screwdriver 80 950 ...
6	031	108	303	041	191
8	033	110	303	042	191
10	036	113	303	043	193
12	037	114	303	044	193
16	037	114	303	045	193
20	037	114	303	046	193
25		131	303	047	
32		131	303	048	

ROHX / XOHX / ROGX

Designation	IC mm	S mm
ROHX0616R..	6	1,60
ROHX0820R..	8	2,00
ROHX1025R..	10	2,50
XOHX10254..	10	2,50
XOHX12255..	12	2,50
RO.X1225R..	12	2,50
RO.X1630R..	16	3,00
XOHX16307..	16	3,00
XOHX20309..	20	3,00
RO.X2030R..	20	3,00
RO.X2540R..	25	4,00
RO.X3250R..	32	5,00

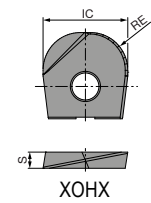
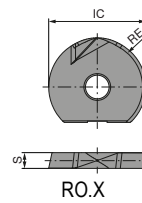

ROHX / XOHX / ROGX

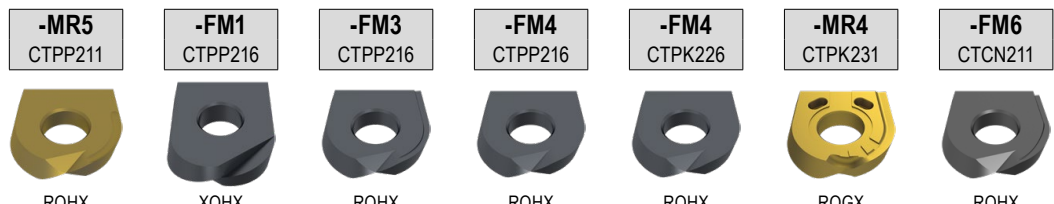

ISO	RE mm	56 149 ...	56 169 ...	56 147 ...	56 141 ...	56 141 ...	56 143 ...	56 145 ...
0616 R3	3,0			30200	90200			602 1)
0820 R4	4,0	71300		31300	71300	11300		613 1)
1025 R5	5,0	72400		32400	72400	12400		624 1)
102540	4,0		92400					
1225 R6	6,0			33500	73500	13500	53500	635 1)
122550	5,0		93500					
1630 R8	8,0			34600	74600	14600	54600	646 1)
163070	7,0		94700					
2030 R10	10,0			35700	75700	15700	55700	
203090	9,0		95900					
2540 R12,5	12,5			36800	76800	16800	56800	
3250 R16	16,0			37900	77900	17900	57900	
P		●	●	●	●	●	●	
M		○	○	○	○	●	●	
K		○	●	●	●	●	●	
N		○	○	○	○	○	○	○
S		○	○	○	○		○	
H		○	●	●	●	○	○	
O		○	○	○	○			●

1) Specifically for machining graphite !

Milling guide

Cutting data standard values	→ 188-189	Depth of Cut	→ 190
Technical Information	→ 193-198	Chip groove description and overview	→ 199-201
Grade description and overview	→ 202-208		

K 2005 / K 2006 shank copy milling cutter

▲ with carbide shank

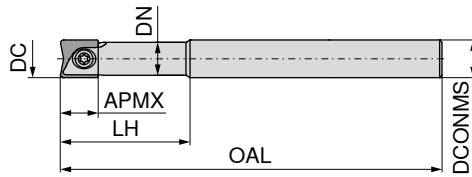
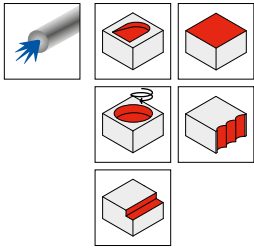

56 110 ...	56 111 ...
081 ¹⁾	
082 ¹⁾	
083 ¹⁾	
101 ¹⁾	
102 ¹⁾	
103 ¹⁾	
121 ¹⁾	121
122 ¹⁾	122
123 ¹⁾	123
	161
	162
	163
	201
	202
	203
	252
	253

Designation	DC mm	APMX mm	DN mm	LH mm	OAL mm	DCONMS mm	torque moment Nm
K2005C.8.27.82	8	9,5	7,0	27	82	8	1
K2005C.8.27.102	8	9,5	7,0	27	102	8	1
K2005C.8.42.152	8	9,5	7,0	42	152	8	1
K2005C.10.37.82	10	11,5	8,8	37	82	10	3
K2005C.10.37.122	10	11,5	8,8	37	122	10	3
K2005C.10.52.152	10	11,5	8,8	52	152	10	3
K2005C/K2006C.12.37.82	12	14,0	10,5	37	82	12	4
K2005C/K2006C.12.37.122	12	14,0	10,5	37	122	12	4
K2005C/K2006C.12.52.162	12	14,0	10,5	52	162	12	4
K2006C.16.42.102	16	16,0	14,0	42	102	16	5
K2006C.16.42.142	16	16,0	14,0	42	142	16	5
K2006C.16.57.177	16	16,0	14,0	57	177	16	5
K2006C.20.52.102	20	18,0	18,0	52	102	20	5
K2006C.20.52.142	20	18,0	18,0	52	142	20	5
K2006C.20.77.192	20	18,0	18,0	77	192	20	5
K2006C.25.62.162	25	23,5	22,4	62	162	25	8
K2006C.25.92.212	25	23,5	22,4	92	212	25	8

1) Without Through Coolant

Applicable inserts

	XOHX-FM2 / -FM5 / -MR2 / -MR3 / -MR6
	XOGX-MF4

K 2007 shank copy milling cutter

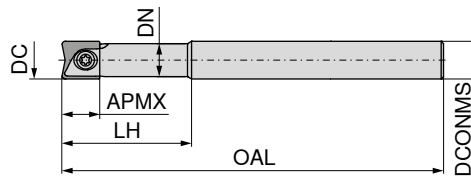
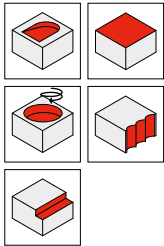

56 112 ...

Designation	DC mm	APMX mm	DN mm	LH mm	OAL mm	DCONMS mm	torque moment Nm	
K2007C.12.34.132	12	14,0	10,5	34	132	12	4	122
K2007C.12.34.92	12	14,0	10,5	34	92	12	4	121
K2007C.12.48.152	12	14,0	10,5	48	152	12	4	123
K2007C.16.38.102	16	16,0	14,0	38	102	16	5	161
K2007C.16.38.142	16	16,0	14,0	38	142	16	5	162
K2007C.16.55.162	16	16,0	14,0	55	162	16	5	163
K2007C.20.47.162	20	18,0	18,0	47	162	20	5	202
K2007C.20.63.177	20	18,0	18,0	63	177	20	5	203
K2007C.25.47.162	25	23,5	22,4	47	162	25	8	252
K2007C.25.72.192	25	23,5	22,4	72	192	25	8	253
K2007C.32.58.177	32	28,0	28,6	58	177	32	8	322
K2007C.32.82.212	32	28,0	28,6	82	212	32	8	323

Applicable inserts

	XOHX-FM2 / -FM5 / -MR2 / -MR3 / -MR6
	XOGX-MF4

K 2005 screw-in copy milling cutter

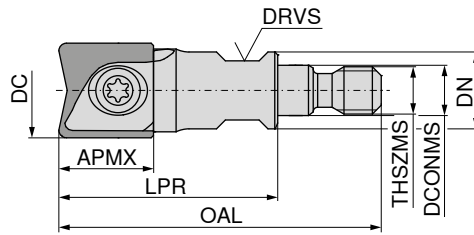
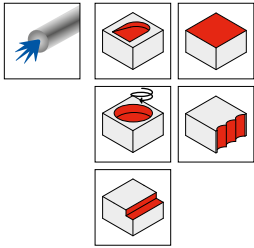

56 130 ...

Designation	DC mm	APMX mm	DN mm	LPR mm	OAL mm	DCONMS mm	THSZMS	DRVS mm	torque moment Nm	
K2005G.8.25.M6	8	9,5	10	25	39,5	6,5	M6	8	1	081 ¹⁾
K2005G.10.25.M6	10	11,5	10	25	39,5	6,5	M6	8	3	101 ¹⁾
K2005G.12.25.M6	12	14,0	10	25	39,5	6,5	M6	8	4	121 ¹⁾
K2005G.12.28.M8	12	14,0	13	28	45,5	8,5	M8	8	4	122
K2005G.16.28.M8	16	16,0	13	28	45,5	8,5	M8	10	5	161
K2005G.20.32.M10	20	18,0	18	32	51,5	10,5	M10	15	5	201
K2005G.25.42.M12	25	23,5	21	42	64,0	12,5	M12	17	8	251
K2005G.32.47.M16	32	28,0	30	47	71,0	17,0	M16	26	8	321

1) Without Through Coolant

Applicable inserts

	XOHX-FM2 / -FM5 / -MR2 / -MR3 / -MR6
	XOGX-MF4

	80 950 ...	80 950 ...	70 950 ...	56 950 ...	80 950 ...
Spare parts					
DC					
8	033	110	303	042	191
10	036	113	303	043	193
12	037	114	303	044	193
16	037	114	303	045	193
20	037	114	303	046	193
25		131	303	047	
32		131	303	048	

XOHX / XOGX

Designation	IC mm	S mm	L mm
XO.X10251..	10	2,50	11,5
XO.X12251..	12	2,50	14,0
XO.X16301..	16	3,00	16,0
XO.X16303..	16	3,00	16,0
XO.X20301..	20	3,00	18,0
XO.X20304..	20	3,00	18,0
XOGX12252..	12	2,50	14,0
XOHX06160..	6	1,60	8,0
XOHX08200..	8	2,00	9,5
XOHX08201..	8	2,00	9,5
XOHX10250..	10	2,50	11,5
XOHX12252..	12	3,00	14,0
XOHX20302..	20	3,00	18,0
XOHX25401..	25	4,00	23,5
XOHX25402..	25	4,00	23,5
XOHX25405..	25	4,00	23,5
XOHX32502..	32	5,00	28,0

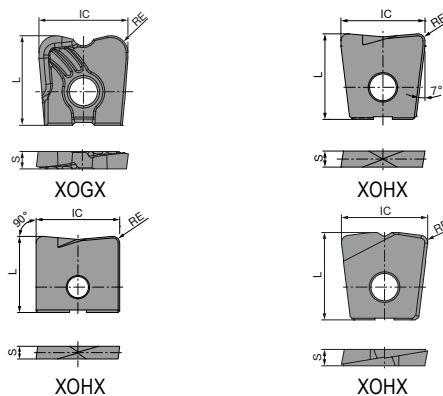

XOHX / XOGX

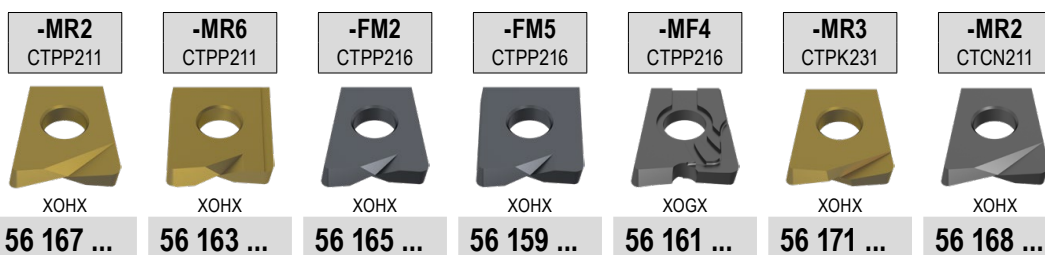

ISO	RE mm	56 167 ...	56 163 ...	56 165 ...	56 159 ...	56 161 ...	56 171 ...	56 168 ...
061605	0,5	71000						610 ¹⁾
082006	0,6		71000	71000	71000			
082010	1,0	71200	71200	71200	71200			612 ¹⁾
102508	0,8		72100	72100	72100		32100	
102510	1,0	72200		72200		92200		622 ¹⁾
122510	1,0	73200	73200	73200	73200	93200	53200	632 ¹⁾
122520	2,0	73500		73500		93500		
163010	1,0	74200		74200		94200		642 ¹⁾
163013	1,3		74300	74300	74300			
163015	1,5						54400	
163030	3,0	74700		74500		94700		
203010	1,0	75200		75200		95200		
203016	1,6		75400	75400	75400			
203020	2,0						55500	
203040	4,0	75800		75800		95800		
254010	1,0	76200		76200				
254020	2,0		76500	76500	76500			
254050	5,0	76900		76900				
325025	2,5		77600		77600			

P	●	●	●	●	●	●	●	
M	○	○	○	○	○	○	●	
K	○	○	●	●	●	●	●	
N	○	○	○	○	○	○	○	○
S	○	○	○	○	○	○	○	
H	○	○	●	●	●	●	○	
O	○	○	○	○	○	○		●

1) Specifically for machining graphite !

Milling guide

Cutting data standard values	→ 188+189	Depth of Cut	→ 190
Technical Information	→ 193-198	Chip groove description and overview	→ 199-201
Grade description and overview	→ 202-208		

Application tips – MaxiMill – Slot-SX

▲ The following components are required to complete the tool:

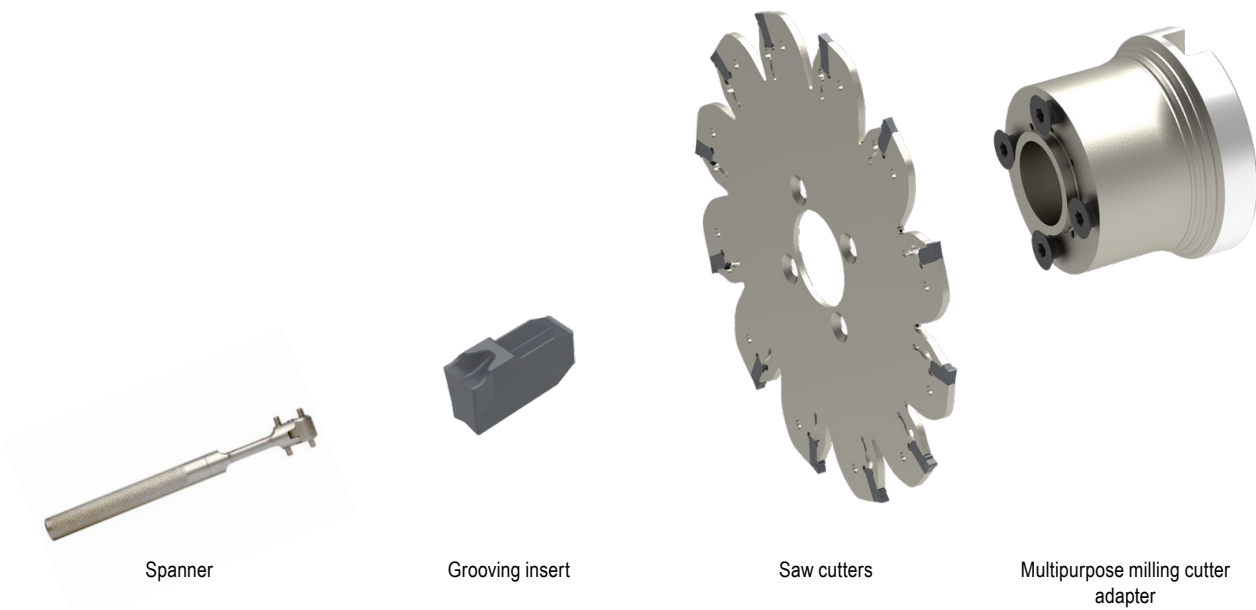

MaxiMill – Slot-SX slot milling and parting off cutter

Scope of supply:

Slot milling and parting off cutters **without** assembly key, **without** clamping screws

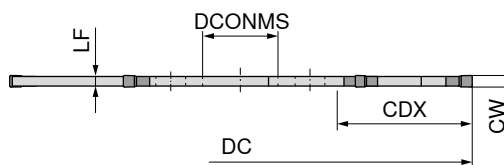
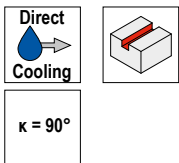

NEW

50 383 ...

Designation	DC mm	CW mm	CDX mm	DCONMS _{H6} mm	LF mm	ZEFP	Insert	Adapter	
ASLOT.80.R.6.13.DC-SX2	80	2	23	13	1,65	6	SX E2 ..	AD.SLOT.13...	08002
ASLOT.80.R.6.13.DC-SX3	80	3	23	13	2,50	6	SX E3 ..	AD.SLOT.13...	08003
ASLOT.80.R.4.13.DC-SX4	80	4	23	13	3,50	4	SX E4 ..	AD.SLOT.13...	08004
ASLOT.80.R.4.13.DC-SX5	80	5	23	13	4,50	4	SX E5 ..	AD.SLOT.13...	08005

Clamping screw	Ejector SX
50 950 ...	70 950 ...
00100	836
00100	836
00100	837
00100	837

Spare parts
for Article no.

50 383 08002	00100	836
50 383 08003	00100	836
50 383 08004	00100	837
50 383 08005	00100	837

Suitable multipurpose milling cutter adapters can be found on → Page 136

MaxiMill – Slot-SX slot milling and parting off cutter

Scope of supply:

Slot milling and parting off cutters **without** assembly key, **without** clamping screws

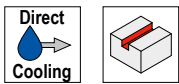

$\kappa = 90^\circ$

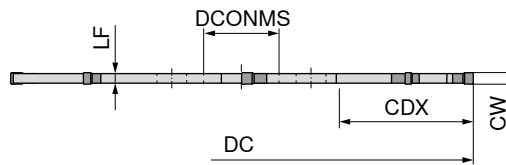

NEW

50 384 ...

Designation	DC mm	CW mm	CDX mm	DCONMS _{H6} mm	LF mm	ZEFP	Insert	Adapter	
ASLOT.100.R.8.22.DC-SX2	100	2	29	22	1,65	8	SX E2 ..	AD.SLOT.22...	10002
ASLOT.100.R.8.22.DC-SX3	100	3	29	22	2,50	8	SX E3 ..	AD.SLOT.22...	10003
ASLOT.100.R.6.22.DC-SX4	100	4	29	22	3,50	6	SX E4 ..	AD.SLOT.22...	10004
ASLOT.100.R.6.22.DC-SX5	100	5	29	22	4,50	6	SX E5 ..	AD.SLOT.22...	10005
ASLOT.100.R.4.22.DC-SX6	100	6	29	22	5,40	4	SX E6 ..	AD.SLOT.22...	10006

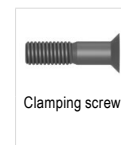

Clamping screw

50 950 ...



Ejector SX

70 950 ...

**Spare parts
for Article no.**

50 384 10002	00100	836
50 384 10003	00100	836
50 384 10004	00100	837
50 384 10005	00100	837
50 384 10006	00100	837

Suitable multipurpose milling cutter adapters can be found on → **Page 136**

MaxiMill – Slot-SX slot milling and parting off cutter

Scope of supply:

Slot milling and parting off cutters **without** assembly key, **without** clamping screws

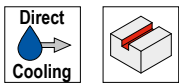

$\kappa = 90^\circ$

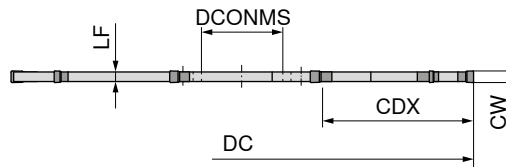

NEW

50 385 ...

Designation	DC mm	CW mm	CDX mm	DCONMS _{H6} mm	LF mm	ZEFP	Insert	Adapter	
ASLOT.125.R.10.22.DC-SX2	125	2	42	22	1,65	10	SX E2 ..	AD.SLOT.22...	12502
ASLOT.125.R.10.22.DC-SX3	125	3	42	22	2,50	10	SX E3 ..	AD.SLOT.22...	12503

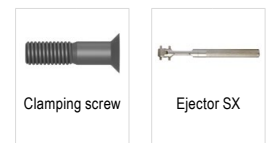

50 950 ...

70 950 ...

**Spare parts
for Article no.**

50 385 12502	00100	836
50 385 12503	00100	836

Suitable multipurpose milling cutter adapters can be found on → **Page 136**

MaxiMill – Slot-SX slot milling and parting off cutter

Scope of supply:

Slot milling and parting off cutters **without** assembly key, **without** clamping screws

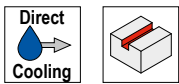

$\kappa = 90^\circ$

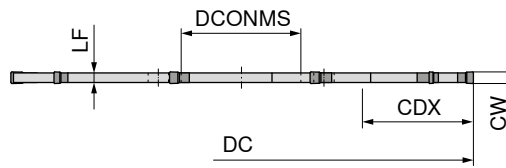

NEW

50 386 ...

Designation	DC mm	CW mm	CDX mm	DCONMS _{H6} mm	LF mm	ZEFP	Insert	Adapter	
ASLOT.125.R.10.32.DC-SX2	125	2	30	32	1,65	10	SX E2 ..	AD.SLOT.32...	12502
ASLOT.125.R.10.32.DC-SX3	125	3	30	32	2,50	10	SX E3 ..	AD.SLOT.32...	12503
ASLOT.125.R.8.32.DC-SX4	125	4	30	32	3,50	8	SX E4 ..	AD.SLOT.32...	12504
ASLOT.125.R.8.32.DC-SX5	125	5	30	32	4,50	8	SX E5 ..	AD.SLOT.32...	12505
ASLOT.125.R.8.32.DC-SX6	125	6	30	32	5,40	8	SX E6 ..	AD.SLOT.32...	12506

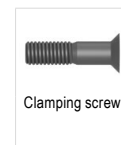

50 950 ...



70 950 ...

**Spare parts
for Article no.**

50 386 12502	00200	836
50 386 12503	00200	836
50 386 12504	00200	837
50 386 12505	00200	837
50 386 12506	00200	837

Suitable multipurpose milling cutter adapters can be found on → **Page 136**

MaxiMill – Slot-SX slot milling and parting off cutter

Scope of supply:

Slot milling and parting off cutters **without** assembly key, **without** clamping screws

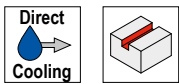

$\kappa = 90^\circ$

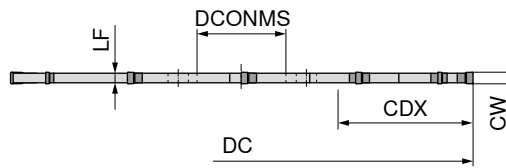

NEW

50 387 ...

Designation	DC mm	CW mm	CDX mm	DCONMS _{H6} mm	LF mm	ZEFP	Insert	Adapter	
ASLOT.160.R.12.32.DC-SX2	160	2	48	32	1,65	12	SX E2 ..	AD.SLOT.32...	16002
ASLOT.160.R.12.32.DC-SX3	160	3	48	32	2,50	12	SX E3 ..	AD.SLOT.32...	16003

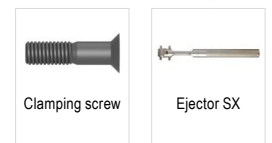

50 950 ...

70 950 ...

**Spare parts
for Article no.**

50 387 16002	00200	836
50 387 16003	00200	836

Suitable multipurpose milling cutter adapters can be found on → **Page 136**

MaxiMill – Slot-SX slot milling and parting off cutter

Scope of supply:

Slot milling and parting off cutters **without** assembly key, **without** clamping screws

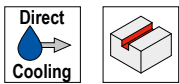

$\kappa = 90^\circ$

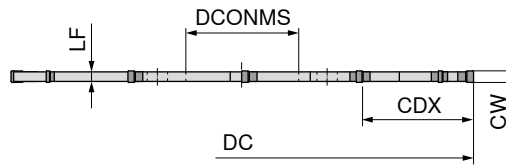

NEW

50 388 ...

Designation	DC mm	CW mm	CDX mm	DCONMS _{H6} mm	LF mm	ZEFP	Insert	Adapter	
ASLOT.160.R.12.40.DC-SX2	160	2	39	40	1,65	12	SX E2 ..	AD.SLOT.40...SK	16002
ASLOT.160.R.12.40.DC-SX3	160	3	39	40	2,50	12	SX E3 ..	AD.SLOT.40...SK	16003
ASLOT.160.R.10.40.DC-SX4	160	4	39	40	3,50	10	SX E4 ..	AD.SLOT.40...SK	16004
ASLOT.160.R.10.40.DC-SX5	160	5	39	40	4,50	10	SX E5 ..	AD.SLOT.40...SK	16005
ASLOT.160.R.10.40.DC-SX6	160	6	39	40	5,40	10	SX E6 ..	AD.SLOT.40...SK	16006

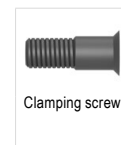

Clamping screw

50 950 ...

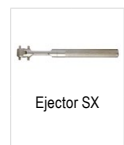

Ejector SX

70 950 ...

Spare parts for Article no.

50 388 16002	00300	836
50 388 16003	00300	836
50 388 16004	00300	837
50 388 16005	00300	837
50 388 16006	00300	837

Suitable multipurpose milling cutter adapters can be found on → **Page 136**

MaxiMill – Slot-SX slot milling and parting off cutter

Scope of supply:

Slot milling and parting off cutters **without** assembly key, **without** clamping screws

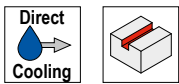

$\kappa = 90^\circ$

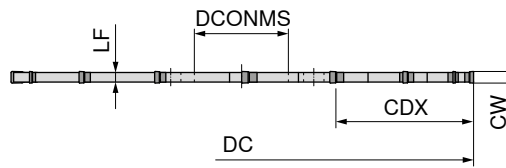

NEW

50 389 ...

Designation	DC mm	CW mm	CDX mm	DCONMS _{H6} mm	LF mm	ZEFP	Insert	Adapter	
ASLOT.200.R.16.40.DC-SX2	200	2	59	40	1,65	16	SX E2 ..	AD.SLOT.40...SK	20002
ASLOT.200.R.16.40.DC-SX3	200	3	59	40	2,50	16	SX E3 ..	AD.SLOT.40...SK	20003
ASLOT.200.R.14.40.DC-SX4	200	4	59	40	3,50	14	SX E4 ..	AD.SLOT.40...SK	20004
ASLOT.200.R.14.40.DC-SX5	200	5	59	40	4,50	14	SX E5 ..	AD.SLOT.40...SK	20005
ASLOT.200.R.14.40.DC-SX6	200	6	59	40	5,40	14	SX E6 ..	AD.SLOT.40...SK	20006

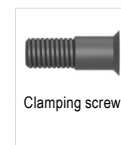

Clamping screw

50 950 ...

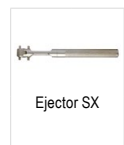

Ejector SX

70 950 ...

**Spare parts
for Article no.**

50 389 20002	00300	836
50 389 20003	00300	836
50 389 20004	00300	837
50 389 20005	00300	837
50 389 20006	00300	837

Suitable multipurpose milling cutter adapters can be found on → **Page 136**

MaxiMill – Slot-SX slot milling and parting off cutter

Scope of supply:

Slot milling and parting off cutters **without** assembly key, **without** clamping screws

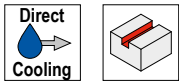

$\kappa = 90^\circ$

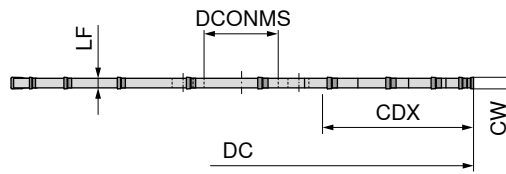

NEW

50 380 ...

Designation	DC mm	CW mm	CDX mm	DCONMS _{H6} mm	LF mm	ZEFP	Insert	Adapter	
ASLOT.250.R.20.40.DC-SX3	250	3	84	40	2,5	20	SX E3 ..	AD.SLOT.40...ZK	25003
ASLOT.250.R.18.40.DC-SX4	250	4	84	40	3,5	18	SX E4 ..	AD.SLOT.40...ZK	25004
ASLOT.250.R.18.40.DC-SX5	250	5	84	40	4,5	18	SX E5 ..	AD.SLOT.40...ZK	25005
ASLOT.250.R.18.40.DC-SX6	250	6	84	40	5,4	18	SX E6 ..	AD.SLOT.40...ZK	25006¹⁾

1) Not ex-stock

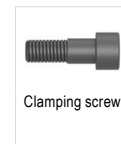

Clamping screw

50 950 ...



Ejector SX

70 950 ...

**Spare parts
for Article no.**

50 380 25003	00400	836
50 380 25004	00400	837
50 380 25005	00400	837
50 380 25006	00400	837

Suitable multipurpose milling cutter adapters can be found on → **Page 136**

MaxiMill – Slot-SX slot milling and parting off cutter

Scope of supply:

Slot milling and parting off cutters **without** assembly key, **without** clamping screws

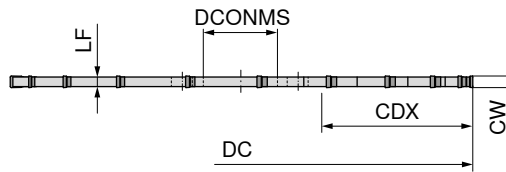
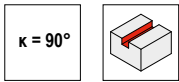

NEW

50 390 ...

Designation	DC mm	CW mm	CDX mm	DCONMS _{H6} mm	LF mm	ZEFP	Insert	Adapter	
ASLOT.250.R.20.40-SX3	250	3	84	40	2,5	20	SX E3 ..	AD.SLOT.40...ZK	25003
ASLOT.250.R.18.40-SX4	250	4	84	40	3,5	18	SX E4 ..	AD.SLOT.40...ZK	25004
ASLOT.250.R.18.40-SX5	250	5	84	40	4,5	18	SX E5 ..	AD.SLOT.40...ZK	25005
ASLOT.250.R.18.40-SX6	250	6	84	40	5,4	18	SX E6 ..	AD.SLOT.40...ZK	25006¹⁾

1) Not ex-stock



50 950 ...

70 950 ...

**Spare parts
for Article no.**

50 390 25003	00400	836
50 390 25004	00400	837
50 390 25005	00400	837
50 390 25006	00400	837

Suitable multipurpose milling cutter adapters can be found on → **Page 136**

MaxiMill – Slot-SX slot milling and parting off cutter

Scope of supply:

Slot milling and parting off cutters **without** assembly key, **without** clamping screws

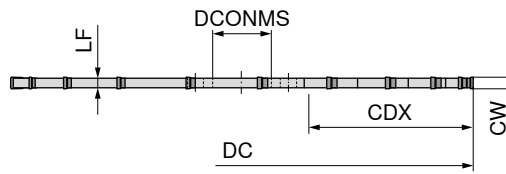
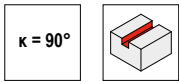



NEW

50 391 ...

Designation	DC mm	CW mm	CDX mm	DCONMS _{H6} mm	LF mm	ZEFP	Insert	Adapter	
ASLOT.315.R.22.40-SX4	315	4	115	40	3,5	22	SX E4 ..	AD.SLOT.40...ZK	31504
ASLOT.315.R.22.40-SX5	315	5	115	40	4,5	22	SX E5 ..	AD.SLOT.40...ZK	31505
ASLOT.315.R.22.40-SX6	315	6	115	40	5,4	22	SX E6 ..	AD.SLOT.40...ZK	31506¹⁾

1) Not ex-stock

	
Clamping screw	Ejector SX
50 950 ...	70 950 ...
00400	837
00400	837
00400	837

**Spare parts
for Article no.**

50 391 31504
50 391 31505
50 391 31506

 Suitable multipurpose milling cutter adapters can be found on → **Page 136**

MaxiMill – Slot-SX multipurpose milling cutter adapter

Scope of supply:

Multipurpose milling cutter adapter including screws

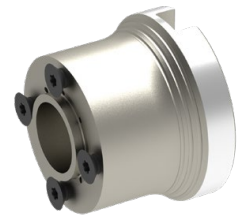
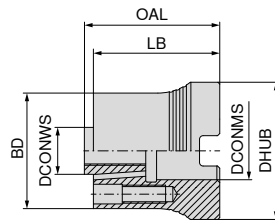

NEW

50 395 ...

Designation	DCONMS mm	DCONWS _{h6} mm	DHUB mm	LB mm	OAL mm	BD mm	
AD.SLOT.13.32.A16	16	13	38	35	37,5	32	01300
AD.SLOT.22.40.A22	22	22	48	35	37,5	40	02200
AD.SLOT.22.40.A22.40	22	22	40	35	37,5	40	02300
AD.SLOT.32.63.A27	27	32	58	45	47,5	63	03200
AD.SLOT.40.80.A32.SK	32	40	78	55	57,5	80	04000
AD.SLOT.40.80.A32.ZK	32	40	78	55	57,5	80	04100

**Spare parts
for Article no.**

- 50 395 01300
- 50 395 02200
- 50 395 03200
- 50 395 04000
- 50 395 04100

Clamping screw	Clamping screw	Clamping screw	Power Screw
50 950 ...	50 950 ...	50 950 ...	70 950 ...
00100			151
00100			
00200			
	00400	00300	

MaxiMill – Slot-SX screw-in multipurpose milling cutter

Scope of supply:

Screw-in multipurpose milling cutter **without** assembly key

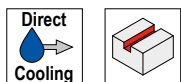

$\kappa = 90^\circ$

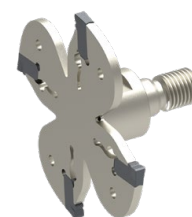
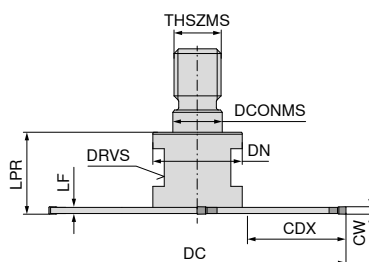

NEW

50 392 ...

Designation	DC mm	CW mm	CDX mm	DCONMS mm	THSZMS	LF mm	DN mm	LPR mm	DRVS mm	ZEFP	Insert	
GSLOT.63.R.4.M10.DC-SX2	63	2	21	10,5	M10	1,65	19	18	15	4	SX E2 ..	06302
GSLOT.63.R.4.M10.DC-SX3	63	3	21	10,5	M10	2,50	19	18	15	4	SX E3 ..	06303

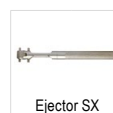

70 950 ...

Spare parts
for Article no.

50 392 06302	836
50 392 06303	836

MaxiMill – Slot-SX screw-in multipurpose milling cutter

Scope of supply:

Screw-in multipurpose milling cutter **without** assembly key

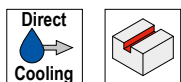

$\kappa = 90^\circ$

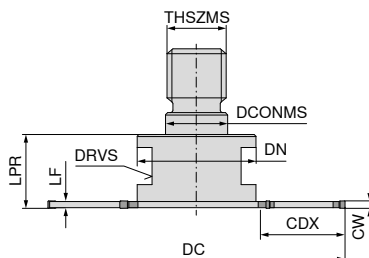

NEW

50 393 ...

Designation	DC mm	CW mm	CDX mm	DCONMS mm	THSZMS	LF mm	DN mm	LPR mm	DRVS mm	ZEFP	Insert	
GSLOT.80.R.6.M16.DC-SX2	80	2	23	17	M16	1,65	32	20	24	6	SX E2 ..	08002
GSLOT.80.R.6.M16.DC-SX3	80	3	23	17	M16	2,50	32	20	24	6	SX E3 ..	08003
GSLOT.80.R.4.M16.DC-SX4	80	4	23	17	M16	3,50	32	20	24	4	SX E4 ..	08004

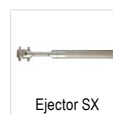

70 950 ...

Spare parts
for Article no.

50 393 08002	836
50 393 08003	836
50 393 08004	837

MaxiMill – Slot-SX screw-in multipurpose milling cutter

Scope of supply:

Screw-in multipurpose milling cutter **without** assembly key

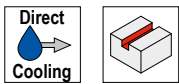

$\kappa = 90^\circ$

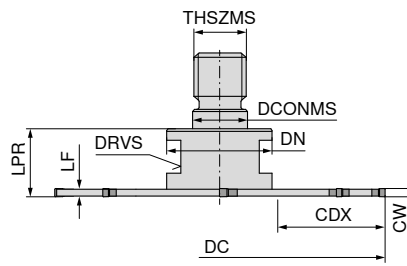

NEW

50 394 ...

Designation	DC mm	CW mm	CDX mm	DCONMS mm	THSZMS	LF mm	DN mm	LPR mm	DRVS mm	ZEFP	Insert	
GSLOT.100.R.8.M16.DC-SX2	100	2	33	17	M16	1,65	32	20	24	8	SX E2 ..	10002
GSLOT.100.R.8.M16.DC-SX3	100	3	33	17	M16	2,50	32	20	24	8	SX E3 ..	10003
GSLOT.100.R.6.M16.DC-SX4	100	4	33	17	M16	3,50	32	20	24	6	SX E4 ..	10004



70 950 ...

**Spare parts
for Article no.**

50 394 10002	836
50 394 10003	836
50 394 10004	837

Suitable adapters for screw-in cutters can be found in – Chapter 16 Adapters and accessories

Insert SX

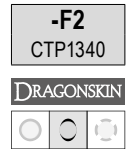
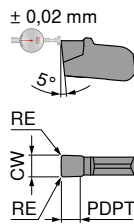
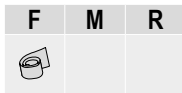

Designation	CW mm	RE mm	PDPT mm	for tool holder
SX E2.00 N 0.20	2	0,2	1,5	-SX2
SX E3.00 N 0.30	3	0,3	2,0	-SX3
SX E4.00 N 0.40	4	0,4	2,5	-SX4

70 346 ...

622
623
624

P	●
M	●
K	○
N	○
S	●
H	
O	

Insert SX

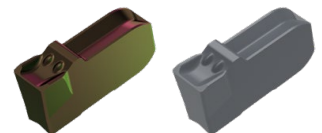
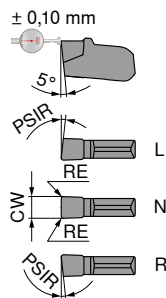
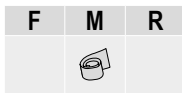
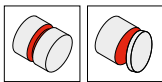

Designation	IH	CW mm	RE mm	for tool holder
SX E2.00 N 0.20	N	2	0,2	-SX2
SX E3.00 N 0.20	N	3	0,2	-SX3
SX E4.00 N 0.30	N	4	0,3	-SX4
SX E5.00 N 0.30	N	5	0,3	-SX5
SX E6.00 N 0.40	N	6	0,4	-SX6

70 342 ...

70 342 ...

52200
523
524
52500
52600

622
623
624
625
626

P	●	●
M	○	●
K	●	○
N		○
S		●
H		
O		

Insert SX

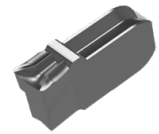
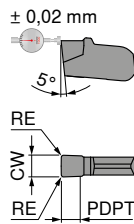
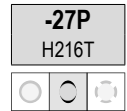

Designation	CW mm	RE mm	PDPT mm	for tool holder
SX E2.00 N 0.20	2	0,2	2,0	-SX2
SX E3.00 N 0.30	3	0,3	2,5	-SX3
SX E4.00 N 0.40	4	0,4	3,0	-SX4

70 349 ...

122
123
124

P	
M	
K	○
N	●
S	
H	
O	○

Insert SX

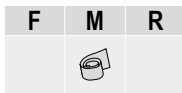
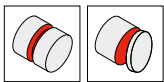

NEW

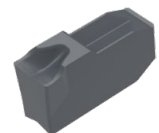
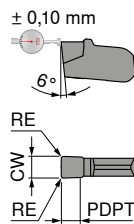

Designation	CW mm	RE mm	PDPT mm	for tool holder
SX E2.00 N 0.20	2	0,2	1,5	-SX2
SX E3.00 N 0.20	3	0,2	2,0	-SX3
SX E4.00 N 0.30	4	0,3	2,5	-SX4
SX E5.00 N 0.30	5	0,3	2,7	-SX5
SX E6.00 N 0.40	6	0,4	3,0	-SX6

70 347 ...

62200
62300
62400
62500
62600

P	●
M	●
K	○
N	○
S	●
H	
O	

Insert SX

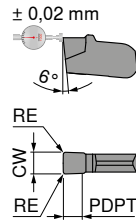
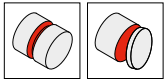

NEW

-M8
CTP1340

DRAGONSKIN



70 348 ...

Designation	CW mm	RE mm	PDPT mm	for tool holder	
SX E2.00 N 0.20	2	0,2	1,5	-SX2	62200
SX E3.00 N 0.20	3	0,2	2,0	-SX3	62300
SX E4.00 N 0.30	4	0,3	2,5	-SX4	62400
SX E5.00 N 0.30	5	0,3	2,7	-SX5	62500
SX E6.00 N 0.40	6	0,4	3,0	-SX6	62600

P	●
M	●
K	○
N	○
S	●
H	
O	

Milling guide

Cutting data standard values	→ 191	Technical Information	→ 193-198
Chip groove description and overview	→ 199-201	Grade description and overview	→ 202-208

TX slot milling and parting off cutter

▲ Note: slot milling and parting off cutters TX are cross-pitched and equipped with indexable inserts for both right-hand and left-hand version.
▲ ZEFP = number of inserts

Scope of supply:

slot milling and parting off cutter, 2 spare clamping screws and 1 Torx key

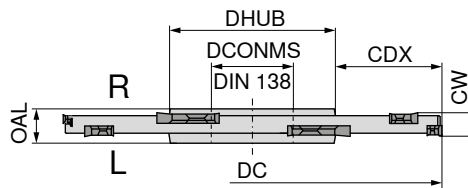

50 730 ...

Designation	DC mm	CW mm	ZNF	CDX mm	DCONMS mm	DHUB mm	OAL mm	ZEFP	Insert	torque moment Nm	
TX.STF.80X27.03.Z4	80	3	4	18,0	27	40	8	8	TX. 161702	0,7	083
TX.STF.100X32.03.Z5	100	3	5	25,0	32	46	8	10	TX. 161702	0,7	103
TX.STF.125X40.03.Z6	125	3	6	32,0	40	54	10	12	TX. 161702	0,7	123
TX.STF.160X40.03.Z8	160	3	8	50,0	40	54	10	16	TX. 161702	0,7	163 ¹⁾
TX.STF.80X27.04.Z4	80	4	4	18,0	27	40	8	8	TX. 162302	1,3	084
TX.STF.100X32.04.Z5	100	4	5	25,0	32	46	8	10	TX. 162302	1,3	104
TX.STF.125X40.04.Z6	125	4	6	32,0	40	54	10	12	TX. 162302	1,3	124
TX.STF.160X40.04.Z8	160	4	8	50,0	40	54	10	16	TX. 162302	1,3	164 ¹⁾
TX.STF.80X27.06.Z4	80	6	4	21,0	27	36	10	8	TX. 223202	2	086
TX.STF.80X22.06.Z4	80	6	4	22,0	22	33	10	8	TX. 223202	2	080
TX.STF.100X32.06.Z5	100	6	5	25,5	32	47	10	10	TX. 223202	2	106
TX.STF.125X40.06.Z6	125	6	6	32,5	40	58	10	12	TX. 223202	2	136
TX.STF.160X40.06.Z8	160	6	8	50,0	40	58	10	16	TX. 223202	2	166 ¹⁾
TX.STF.80X27.08.Z4	80	8	4	21,0	27	36	12	8	TX. 224302	2,8	088
TX.STF.100X32.08.Z5	100	8	5	25,5	32	47	12	10	TX. 224302	2,8	108
TX.STF.125X40.08.Z6	125	8	6	32,5	40	58	12	12	TX. 224302	2,8	138
TX.STF.160X40.08.Z8	160	8	8	50,0	40	58	12	16	TX. 224302	2,8	168 ¹⁾
TX.STF.80X27.10.Z4	80	10	4	21,0	27	36	12	8	TX. 225402	3	090
TX.STF.100X32.10.Z5	100	10	5	25,5	32	47	12	10	TX. 225402	3	110
TX.STF.125X40.10.Z6	125	10	6	32,5	40	58	14	12	TX. 225402	3	140
TX.STF.160X40.10.Z8	160	10	8	50,0	40	58	14	16	TX. 225402	3	170 ¹⁾

1) Without Through Coolant

	TORX® blade	Key D	Molykote	Clamping screw	Torque screwdriver
80 950 ...					
80 950 ...					
70 950 ...					
70 950 ...					
80 950 ...					
Spare parts					
CW					
3	032	109	303	858	191
4	033	110	303	218	191
6	036	113	303	101	192
8	037	114	303	135	192
10	037	114	303	146	192

TX shell / slot milling and parting off cutter

▲ Note: slot milling and parting off cutters TX are cross-pitched and equipped with indexable inserts for both right-hand and left-hand version.
▲ ZEFP = number of inserts

Scope of supply:

slot milling and parting off cutter, 2 spare clamping screws and 1 Torx key

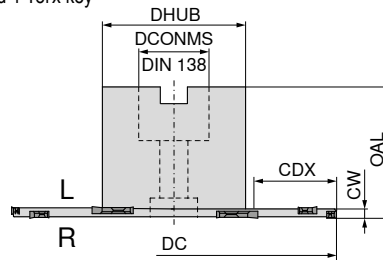

50 734 ...

Designation	DC mm	CW mm	ZNF	CDX mm	DCONMS mm	DHUB mm	OAL mm	ZEFP	torque moment Nm	Insert	
TX.ASF.100.R.03.Z5	100	3	5	25,0	27	48	50	10	0,7	TX. 161702	300
TX.ASF.125.R.03.Z6	125	3	6	37,5	27	48	50	12	0,7	TX. 161702	225
TX.ASF.160.R.03.Z8	160	3	8	44,0	40	70	50	16	0,7	TX. 161702	260 ¹⁾
TX.ASF.100.R.04.Z5	100	4	5	25,0	27	48	50	10	3,2	TX. 162302	100
TX.ASF.125.R.04.Z6	125	4	6	37,5	27	48	50	12	3,2	TX. 162302	025
TX.ASF.125.R.04.Z6	125	4	6	26,5	40	70	50	12	3,2	TX. 162302	125
TX.ASF.160.R.04.Z8	160	4	8	55,0	27	48	50	16	3,2	TX. 162302	060 ¹⁾
TX.ASF.160.R.04.Z8	160	4	8	44,0	40	70	50	16	3,2	TX. 162302	160 ¹⁾
TX.ASF.180.R.04.Z9	180	4	9	54,0	40	70	50	18	3,2	TX. 162302	180 ¹⁾
TX.ASF.200.R.04.Z10	200	4	10	64,0	40	70	50	20	3,2	TX. 162302	200 ¹⁾

1) Without Through Coolant

	Washer	TORX® blade	Clamping Screw	Key D	Molykote	Clamping screw	Torque screwdriver
	70 950 ...	80 950 ...	70 950 ...	80 950 ...	70 950 ...	70 950 ...	80 950 ...
Spare parts							
CW	DCONMS						
3	27	221	032	219	109	303	858
3	40	222	032	220	109	303	858
4	27	221	033	219	110	303	218
4	40	222	033	220	110	303	218

TX-L / TX-R

Designation	IC mm	D1 mm	CW mm
TX . 1617..	10	3,95	1,7
TX . 1623..	10	3,95	2,3
TX . 2232..	13	5,50	3,2
TX . 2243..	13	5,50	4,3
TX . 2254..	13	5,50	5,4

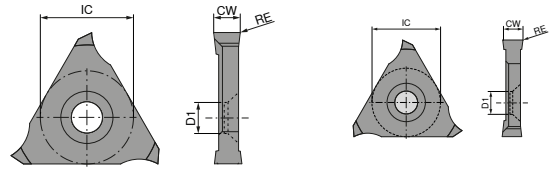

TX_L / TX_R

ISO	RE mm	CWX500		CWK10	
		TX-L 50 382 ...	TX-R 50 381 ...	TX-L 50 382 ...	TX-R 50 381 ...
TX 161702	0,15	217	217		
TX 162302	0,15	223	223		
TX 223202	0,15	232	232		
TX 223202	0,20			532	532
TX 224302	0,15	243	243		
TX 224302	0,20			543	543
TX 225402	0,15	254	254		
TX 225402	0,20			554	554
P		●	●		
M		●	●		
K		●	●		
N		●	●	●	●
S		○	○		
H					
O		○	○	○	○

Milling guide

Cutting data standard values	→ 192	Technical Information	→ 193-198
Chip groove description and overview	→ 199-201	Grade description and overview	→ 202-208

Material examples for cutting data tables

	Material sub-group	Index	Composition / Structure / Heat treatment	Tensile strength N/mm ² / HB / HRC	Material number	Material designation	Material number	Material designation
P	Unalloyed steel	P.1.1	< 0,15 % C Annealed	420 N/mm ² / 125 HB	1.0401	C15	1.1141	Ck15
		P.1.2	< 0,45 % C Annealed	640 N/mm ² / 190 HB	1.1191	C45E	1.0718	9SMnPb28
		P.1.3	< 0,45 % C Tempered	840 N/mm ² / 250 HB	1.1191	C45E	1.0535	C55
		P.1.4	< 0,75 % C Annealed	910 N/mm ² / 270 HB	1.1223	C60R	1.0535	C55
		P.1.5	< 0,75 % C Tempered	1010 N/mm ² / 300 HB	1.1223	C60R	1.0727	45S20
	Low-alloy steel	P.2.1	Annealed	610 N/mm ² / 180 HB	1.7131	16MnCr5	1.6587	17CrNiMo6
		P.2.2	Tempered	930 N/mm ² / 275 HB	1.7131	16MnCr5	1.6587	17CrNiMo6
		P.2.3	Tempered	1010 N/mm ² / 300 HB	1.7225	42CrMo4	1.3505	100Cr6
		P.2.4	Tempered	1200 N/mm ² / 375 HB	1.7225	42CrMo4	1.3505	100Cr6
	High-alloy steel and high-alloy tool steel	P.3.1	Annealed	680 N/mm ² / 200 HB	1.4021	X20Cr13	1.4034	X46Cr13
		P.3.2	Hardened and tempered	1100 N/mm ² / 300 HB	1.2343	X38CrMoV5-1	1.4034	X46Cr13
		P.3.3	Hardened and tempered	1300 N/mm ² / 400 HB	1.2343	X38CrMoV5-1	1.4034	X46Cr13
	Stainless steel	P.4.1	Ferritic / martensitic Annealed	680 N/mm ² / 200 HB	1.4016	X6Cr17	1.2316	X36CrMo16
		P.4.2	Martensitic Tempered	1010 N/mm ² / 300 HB	1.4112	X90CrMoV18	1.2316	X36CrMo16
M	Stainless steel	M.1.1	Austenitic / austenitic-ferritic Quenched	610 N/mm ² / 180 HB	1.4301	X5CrNi18-10	1.4571	X6CrNiMoTi17-12-2
		M.2.1	Austenitic Tempered	300 HB	1.4841	X15CrNiSi25-21	1.4539	X1NiCrMoCu25-20-5
		M.3.1	Austenitic / ferritic (Duplex)	780 N/mm ² / 230 HB	1.4462	X2CrNiMoN22-5-3	1.4501	X2CrNiMoCuWN25-7-4
K	Grey cast iron	K.1.1	Pearlitic / ferritic	350 N/mm ² / 180 HB	0.6010	GG-10	0.6025	GG-25
		K.1.2	Pearlitic (martensitic)	500 N/mm ² / 260 HB	0.6030	GG-30	0.6045	GG-45
	Spherulitic graphite cast iron	K.2.1	Ferritic	540 N/mm ² / 160 HB	0.7040	GGG-40	0.7060	GGG-60
		K.2.2	Pearlitic	845 N/mm ² / 250 HB	0.7070	GGG-70	0.7080	GGG-80
	Malleable iron	K.3.1	Ferritic	440 N/mm ² / 130 HB	0.8035	GTW-35-04	0.8045	GTW-45
		K.3.2	Pearlitic	780 N/mm ² / 230 HB	0.8165	GTS-65-02	0.8170	GTS-70-02
N	Aluminium wrought alloy	N.1.1	Non-hardenable	60 HB	3.0255	Al99,5	3.3315	AlMg1
		N.1.2	Hardenable Age-hardened	340 N/mm ² / 100 HB	3.1355	AlCuMg2	3.2315	AlMgSi1
	Cast aluminium alloy	N.2.1	≤ 12 % Si, non-hardenable	250 N/mm ² / 75 HB	3.2581	G-AlSi12	3.2163	G-AlSi9Cu3
		N.2.2	≤ 12 % Si, hardenable Age-hardened	300 N/mm ² / 90 HB	3.2134	G-AlSi5Cu1Mg	3.2373	G-AlSi9Mg
		N.2.3	> 12 % Si, non-hardenable	440 N/mm ² / 130 HB		G-AlSi17Cu4Mg		G-AlSi18CuNiMg
	Copper and copper alloys (bronze/brass)	N.3.1	Free-machining alloys, PB > 1 %	375 N/mm ² / 110 HB	2.0380	CuZn39Pb2 (Ms58)	2.0410	CuZn44Pb2
		N.3.2	CuZn, CuSnZn	300 N/mm ² / 90 HB	2.0331	CuZn15	2.4070	CuZn28Sn1As
		N.3.3	CuSn, lead-free copper and electrolytic copper	340 N/mm ² / 100 HB	2.0060	E-Cu57	2.0590	CuZn40Fe
	Magnesium alloys	N.4.1	Magnesium and magnesium alloys	70 HB	3.5612	MgAl6Zn	3.5312	MgAl3Zn
	S	Heat-resistant alloys	S.1.1	Fe - basis Annealed	680 N/mm ² / 200 HB	1.4864	X12NiCrSi 36-16	1.4865
S.1.2			Fe - basis Age-hardened	950 N/mm ² / 280 HB	1.4980	X6NiCrTiMoVB25-15-2	1.4876	X10NiCrAlTi32-20
S.2.1			Ni or Co basis Annealed	840 N/mm ² / 250 HB	2.4631	NiCr20TiAl (Nimonic80A)	3.4856	NiCr22Mo9Nb
S.2.2			Ni or Co basis Age-hardened	1180 N/mm ² / 350 HB	2.4668	NiCr19Nb5Mo3 (Inconel 718)	2.4955	NiFe25Cr20NbTi
S.2.3			Ni or Co basis Cast	1080 N/mm ² / 320 HB	2.4765	CoCr20W15Ni	1.3401	G-X120Mn12
Titanium alloys		S.3.1	Pure titanium	400 N/mm ²	3.7025	Ti99,8	3.7034	Ti99,7
		S.3.2	Alpha + beta alloys Age-hardened	1050 N/mm ² / 320 HB	3.7165	TiAl6V4	Ti-6246	Ti-6Al-2Sn-4Zr-6Mo
		S.3.3	Beta alloys	1400 N/mm ² / 410 HB	Ti555.3	Ti-5Al-5V-5Mo-3Cr	R56410	Ti-10V-2Fe-3Al
H	Hardened steel	H.1.1	Hardened and tempered	46–55 HRC				
		H.1.2	Hardened and tempered	56–60 HRC				
		H.1.3	Hardened and tempered	61–65 HRC				
		H.1.4	Hardened and tempered	66–70 HRC				
	Chilled iron	H.2.1	Cast	400 HB				
Hardened cast iron	H.3.1	Hardened and tempered	55 HRC					
O	Non-metal materials	O.1.1	Plastics, duroplastic	≤ 150 N/mm ²				
		O.1.2	Plastics, thermoplastic	≤ 100 N/mm ²				
		O.2.1	Aramid fibre-reinforced	≤ 1000 N/mm ²				
		O.2.2	Glass/carbon-fibre reinforced	≤ 1000 N/mm ²				
		O.3.1	Graphite					

* Tensile strength

Cutting data standard values

Index	CTEP210		TCM10		CTCP220		CTPP225		CTCP230		CTPP231		CTPP235		CTPP236	
	CERMET		CERMET		DRAGONSKIN		DRAGONSKIN		DRAGONSKIN		DRAGONSKIN		DRAGONSKIN		DRAGONSKIN	
	Cutting Material hard ($v_c \uparrow$) → tough ($v_c \downarrow$) v_c (m/min)															
P.1.1	344		292		339	170	263	157	286	150	200	100	246	137	300	180
P.1.2	302		257		308	154	234	143	242	133	170	90	208	121	270	160
P.1.3	263		224		280	140	207	129	202	118	140	80	172	106	225	130
P.1.4	250		214		270	135	198	125	189	112	170	90	160	101	270	160
P.1.5	230		197		256	128	185	118	169	105	160	90	143	94	240	140
P.2.1	308		262		313	157	238	145	249	136	170	90	214	123	270	160
P.2.2	246		211		268	134	196	124	185	111	130	70	157	100	200	120
P.2.3	230		197		256	128	185	118	169	105	170	90	143	94	270	160
P.2.4	181		157		220	110	151	102	118	85	120	60	98	76	180	110
P.3.1					140	70	130	65	140	87	170	90	121	97	270	160
P.3.2					95	50	100	50	90	55	140	80	108	83	180	140
P.3.3					50	30	70	35	40	22	120	70	96	69	150	120
P.4.1					140	70	130	65	140	87	140	80	121	97	180	140
P.4.2					118	60	115	58	115	71	130	70	114	90	170	130
M.1.1											170	90	121	97	270	160
M.2.1													108	83		
M.3.1													117	93		
K.1.1									310	190	150	110	160	110	360	90
K.1.2	300		240						160	100	150	110	150	110	360	90
K.2.1	350		280						200	120	150	110	150	110	230	170
K.2.2	300		240						130	80	150	110	150	110	160	110
K.3.1	300		240						190	115					210	160
K.3.2									160	100					210	160
N.1.1																
N.1.2																
N.2.1																
N.2.2																
N.2.3																
N.3.1																
N.3.2																
N.3.3																
N.4.1																
S.1.1																
S.1.2																
S.2.1																
S.2.2																
S.2.3																
S.3.1																
S.3.2																
S.3.3																
H.1.1																
H.1.2																
H.1.3																
H.1.4																
H.2.1																
H.3.1																
O.1.1																
O.1.2																
O.2.1																
O.2.2																
O.3.1																

The cutting data is strongly influenced by external conditions, such as the stability of the tool and workpiece clamping, material and type of machine. The specified values represent guideline cutting data that can be adjusted by approx. ±20% according to the usage conditions.

Cutting data standard values

Index	CTPM225		CTCM235		CTPM240		CTPM241		CTPM245		CTCM245		CTN3105		CTL3215			
	DRAGONSKIN														CERAMIC		CBN	
	Cutting Material hard ($v_c \uparrow$) → tough ($v_c \downarrow$) v_c (m/min)																	
P.1.1	272	191	251	184	226	141	200	100	244	139	279	134						
P.1.2	231	163	210	152	188	126	170	90	207	124	242	119						
P.1.3	193	137	172	123	152	112	140	70	173	109	208	104						
P.1.4	180	129	160	113	140	107	170	90	161	104	196	99						
P.1.5	161	116	141	99	123	100	150	80	144	97	179	92						
P.2.1	237	167	217	157	194	128	170	90	212	126	247	121						
P.2.2	177	127	157	111	137	106	120	60	158	103	193	98						
P.2.3	161	116	141	99	123	100	170	90	144	97	179	92						
P.2.4	114	84	94	62	78	83	110	60	101	78	136	73						
P.3.1	148	121	136	115	126	105	210	100	155	107	175	122						
P.3.2	121	101	128	110	112	95	180	100	143	93	163	108						
P.3.3	95	81	120	105	98	85	160	90	131	79	151	94						
P.4.1	148	121	136	115	126	105	140	90	155	107	175	122						
P.4.2	134	111	132	113	119	100	130	80	149	100	169	115						
M.1.1	148	121	136	115	126	105	210	100	155	107	175	122						
M.2.1	121	101	128	110	112	95	180	90	143	93	163	108						
M.3.1	140	115	134	114	121	102	210	100	152	103	172	118						
K.1.1													800		800			
K.1.2													600		600			
K.2.1																		
K.2.2															450			
K.3.1																		
K.3.2																		
N.1.1																		
N.1.2																		
N.2.1																		
N.2.2																		
N.2.3																		
N.3.1																		
N.3.2																		
N.3.3																		
N.4.1																		
S.1.1								60				80						
S.1.2								60				70						
S.2.1								60				35						
S.2.2								60				25						
S.2.3								60				30						
S.3.1								60				80						
S.3.2								60				50						
S.3.3								60				40						
H.1.1																		
H.1.2															150			
H.1.3																		
H.1.4																		
H.2.1															280			
H.3.1																		
O.1.1																		
O.1.2																		
O.2.1																		
O.2.2																		
O.3.1																		

The cutting data is strongly influenced by external conditions, such as the stability of the tool and workpiece clamping, material and type of machine. The specified values represent guideline cutting data that can be adjusted by approx. ±20% according to the usage conditions.

Cutting data standard values

Index	CTCK215		CTPK220		CTPK221		CTPX715		H216T		CTWN215		CTC5240		CTCS245		CTP6215	
	DRAGONSKIN		DRAGONSKIN				DRAGONSKIN						DRAGONSKIN					
	Cutting Material hard (v _{c↑}) → tough (v _{c↓}) v _c (m/min)																	
P.1.1					190	120	240	130										
P.1.2					180	100	200	120										
P.1.3					150	80	170	100										
P.1.4					180	100	160	100										
P.1.5					170	90	140	90										
P.2.1					180	100	210	120										
P.2.2					140	80	150	100										
P.2.3					180	100	140	90										
P.2.4					130	80	100	70										
P.3.1					210	120	120	90										
P.3.2					160	90	100	80										
P.3.3					130	80	90	70										
P.4.1					210	120	120	90										
P.4.2					190	100	110	90										
M.1.1							120	100										
M.2.1							110	90										
M.3.1							120	100										
K.1.1	360	210	320	190	270	200	320	190	130	130	130	130					280	250
K.1.2	220	130	170	100	270	200	170	100	110	110	110	110					190	160
K.2.1	230	140	210	130	250	180	210	130	130	130	130	130					180	150
K.2.2	160	100	140	90	180	120	140	90	120	120	120	120					180	150
K.3.1	250	150	200	120	220	170	200	120	130	130	130	130					250	220
K.3.2	210	130	170	100	220	170	170	100	110	120	110	110					190	160
N.1.1								1500		1500		1500						
N.1.2								1000		1000		1000						
N.2.1								1100		1100		1100						
N.2.2								1000		1000		1000						
N.2.3								280		280		280						
N.3.1								350		350		350						
N.3.2								350		350		350						
N.3.3								320		320		320						
N.4.1								320		320		320						
S.1.1								60					80		64			
S.1.2								50					70		56			
S.2.1								30					35		28			
S.2.2								20					25		20			
S.2.3								20					30		24			
S.3.1								60					80		64			
S.3.2								40					50		40			
S.3.3								30					40		32			
H.1.1																	50	
H.1.2																	40	
H.1.3																		
H.1.4																		
H.2.1																		
H.3.1																		
O.1.1							160	160	160	160	160	160						
O.1.2																		
O.2.1							240	240	240	240	240	240						
O.2.2																		
O.3.1																		

The cutting data is strongly influenced by external conditions, such as the stability of the tool and workpiece clamping, material and type of machine. The specified values represent guideline cutting data that can be adjusted by approx. ±20% according to the usage conditions.

System MaxiMill 274-04/-09

Machining strategy

Helical plunging

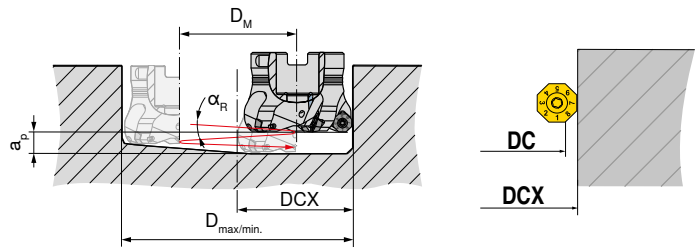

D_{max} in mm = largest diameter for flat bottom hole
 D_{min} in mm = smallest hole diameter for flat bottom surface
 $D_M = D_{max} - DCX$ and $D_{min} - DCX$

OF..04

DC mm	DCX mm	D_{max} mm	D_{min} mm	$\alpha_{R,max}$ °
20	25,5	45	39	2,3
25	30,6	55	49	1,9
32	37,6	69	63	1,4
40	45,7	85	79	1,2
50	55,7	105	99	0,9
63	68,7	131	125	0,7
80	85,7	165	159	0,6
100	105,7	205	199	0,5
125	130,7	255	249	0,4

SF..09

DC mm	DCX mm	D_{max} mm	D_{min} mm	$\alpha_{R,max}$ °
18,8	27,4	45,00	42,0	1,9
23,8	32,5	55,00	52,0	1,5
30,7	39,5	69,00	66,0	1,1
38,7	47,6	85,00	82,0	0,9
48,6	57,6	105,00	102,0	0,7
61,7	70,6	131,00	128,0	0,5
78,7	87,5	165,00	162,0	0,4
98,7	107,5	205,00	202,0	0,3
123,7	132,5	255,00	252,0	0,3

Axial ramping

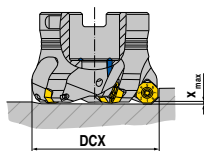

OF..04

DC mm	DCX mm	X_{max} mm
20	25,6	2,5
25	30,7	2,5
32	37,7	2,5
40	45,7	2,5
50	55,7	2,5
63	68,7	2,5
80	85,7	2,5
100	105,7	2,5
125	130,7	2,5

SF..09

DC mm	DCX mm	X_{max} mm
18,8	27,4	3,7
23,8	32,5	3,5
30,7	39,5	3,2
38,7	47,6	3,1
48,6	57,6	3,1
61,7	70,6	3,0
78,7	87,5	2,9
98,7	107,5	2,7
123,7	132,5	2,7

Angled ramping

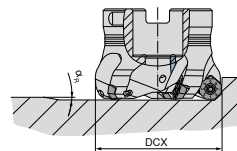

OF..04

DC mm	DCX mm	$\alpha_{R,max}$ °
20	25,6	14,2
25	30,7	9,5
32	37,7	6,5
40	45,7	4,7
50	55,7	3,5
63	68,7	2,7
80	85,7	2,0
100	105,7	1,6
125	130,7	1,2

SF..09

DC mm	DCX mm	$\alpha_{R,max}$ °
18,8	27,4	20,4
23,8	32,5	13,0
30,7	39,5	8,0
38,7	47,6	5,8
48,6	57,6	4,3
61,7	70,6	3,2
78,7	87,5	2,3
98,7	107,5	1,7
123,7	132,5	1,3

System MaxiMill 274-04

Starting Parameter

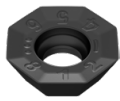

OF.. 04

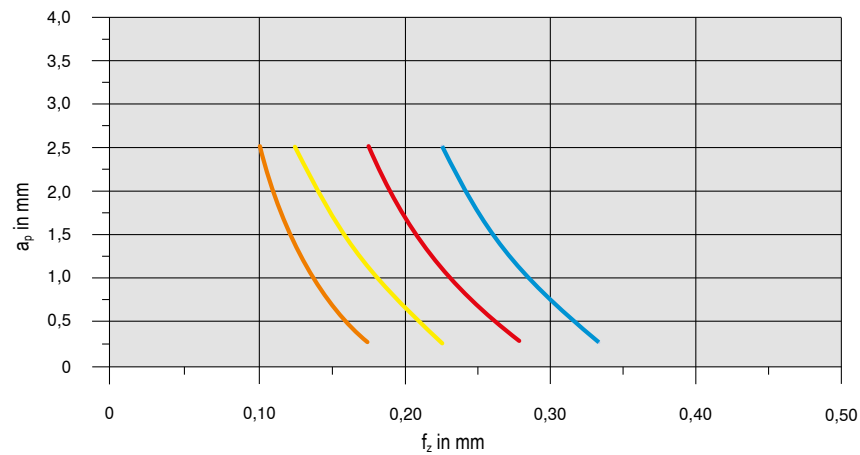

Material		Inserts		v_c in m/min	Cooling
Steel	P.2.2 40CrMnMoS 8-6	OFHT040305SN-M50	CTPP235	200	Dry
Stainless steel	M.1.1 X6CrNiMoTi 1712 2	OFHT040305SN-F50	CTPM240	180	Dry
Cast iron	K.1.1 EN-GJL-250 (GG25)	OFHT040305SN-M50	CTCK215	250	Dry
Heat-resistant	S.2.2 Inconel 718	OFHT040305SN-F50	CTC5240	35	Emulsion

System MaxiMill 274-09

Starting Parameter

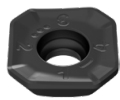

SF.. 09

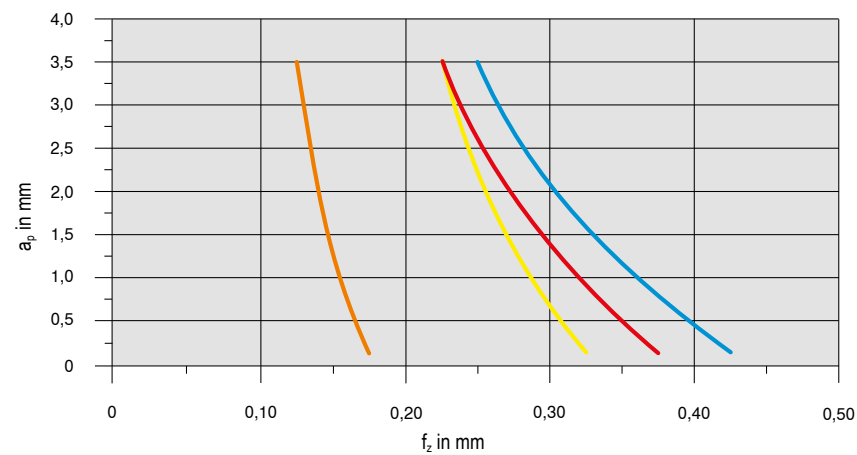

Material		Inserts		v_c in m/min	Cooling
Steel	P.2.2 40CrMnMoS 8-6	SFKT0903AFSR-M50	CTPP235	200	Dry
Stainless steel	M.1.1 X6CrNiMoTi 1712 2	SFHT0903AFSR-F50	CTPM240	180	Dry
Cast iron	K.1.1 EN-GJL-250 (GG25)	SFKT0903AFSR-R50	CTCK215	250	Dry
Heat-resistant	S.2.2 Inconel 718	SFHT0903AFSR-F50	CTC5240	35	Emulsion



Detailed information on cutting speed for each grade can be found on → page 146–148

From $v_c > 400$ m/min, the tool must be balanced!

System MaxiMill 274-05/-12

Machining strategy

Helical plunging

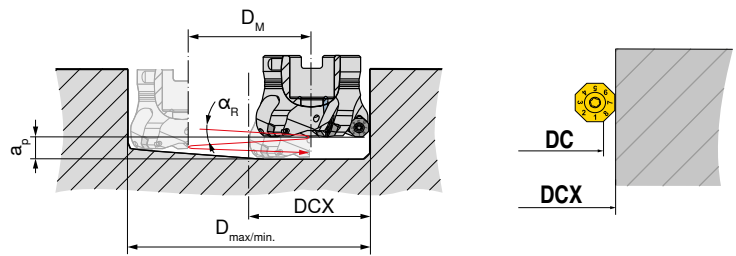

D_{max} in mm = largest diameter for flat bottom hole
 D_{min} in mm = smallest hole diameter for flat bottom surface
 $D_M = D_{max} - DCX$ and $D_{min} - DCX$

OF..05

DC mm	DCX mm	D_{max} mm	D_{min} mm	$\alpha_{R,max}$ °
40	48	87	85	1,6
50	58	107	99	1,1
63	71	133	125	0,9
80	88	167	159	0,7
100	107,9	207	199	0,5
125	132,9	257	249	0,4
160	167,9	327	325	0,35

SF..12

DC mm	DCX mm	D_{max} mm	D_{min} mm	$\alpha_{R,max}$ °
47,0	61,0	107	105	0,5
59,9	74,0	133	131	0,4
76,9	90,9	167	165	0,3
96,9	110,9	207	205	0,25
121,9	135,9	257	255	0,2

Axial ramping

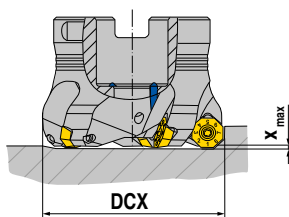

OF..05

DC mm	DCX mm	X_{max} mm
40	48	2,5
50	58	2,2
63	71	1,9
80	88	1,8
100	107,9	1,1
125	132,9	1,4
160	167,9	1,1

SF..12

DC mm	DCX mm	X_{max} mm
47,0	61,0	3,4
59,9	74,0	3,2
76,9	90,9	3,0
96,9	110,9	2,5
121,9	135,9	2,6

Angled ramping

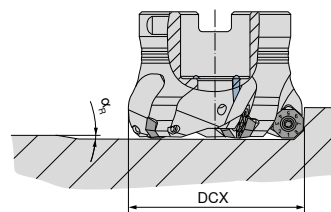

OF..05

DC mm	DCX mm	$\alpha_{R,max}$ °
40	48	6,5
50	58	3,2
63	71	2,0
80	88	1,5
100	107,9	0,7
125	132,9	0,7
160	167,9	0,4

SF..12

DC mm	DCX mm	$\alpha_{R,max}$ °
47,0	61,0	4,9
59,9	74,0	3,4
76,9	90,9	2,4
96,9	110,9	1,6
121,9	135,9	1,3

System MaxiMill 274-05

Starting Parameter



OF.. 05

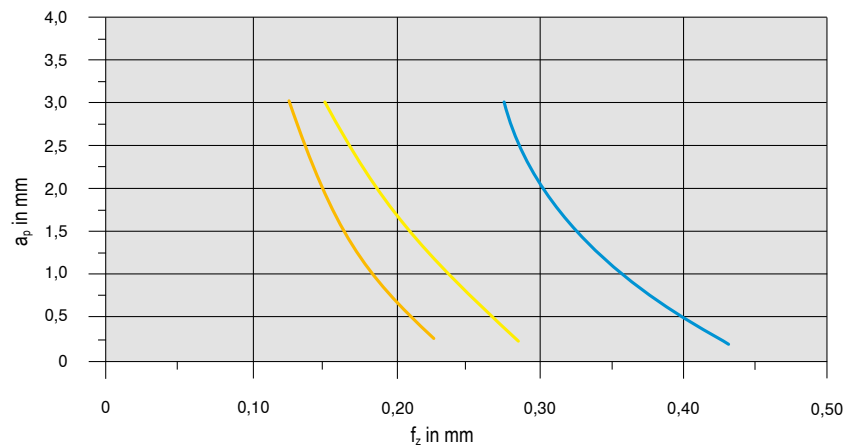

Material			Inserts		v _c in m/min	Cooling
Steel	P.2.2	40CrMnMoS 8-6	OFHT050410SN-M50	CTCP230	200	Dry
Stainless steel	M.1.1	X6CrNiMoTi 1712 2	OFHT050410SN-F50	CTPM240	180	Dry
Heat-resistant	S.2.2	Inconel 718	OFHT050410SN-F50	CTC5240	35	Emulsion

System MaxiMill 274-12

Starting Parameter

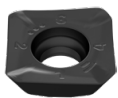

SF.. 12

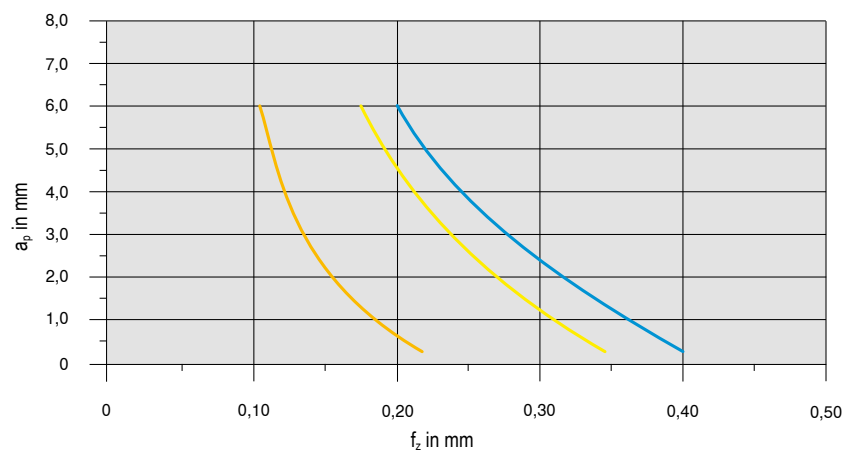

Material			Inserts		v _c in m/min	Cooling
Steel	P.2.2	40CrMnMoS 8-6	SFKT1204AFSR-M50	CTPP235	200	Dry
Stainless steel	M.1.1	X6CrNiMoTi 1712 2	SFKT1204AFSR-M50	CTPM240	180	Dry
Heat-resistant	S.2.2	Inconel 718	SFHT1204AFER-F40	CTC5240	35	Emulsion



Detailed information on cutting speed for each grade can be found on → page 146–148

From v_c > 400 m/min, the tool must be balanced!

MaxiMill 271-12 system

Starting Parameter

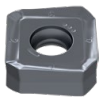

SOHU 12

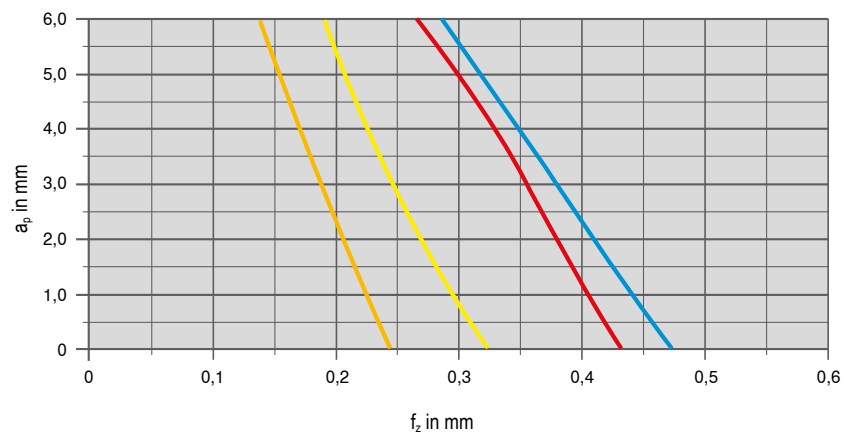

Material	Material	Material	Inserts	Inserts	vc in m/min	Cooling
Steel	P.2.2	40CrMnMoS 8-6	SOHU 1204ABSR-M50	CTPP230	200	Dry
Stainless steel	M.1.1	X6CrNiMoTi 1712 2	SOHU 1204ABSR-M50	CTPM240	180	Dry
Cast iron	K.1.1	EN-GJL-250 (GG25)	SOHU 1204ABSR-R50	CTCK215	300	Dry
Heat-resistant	S.2.2	Inconel 718	SOHU 1204ABSR-F50	CTC5240	30	Emulsion

System MaxiMill 271-17

Starting Parameter

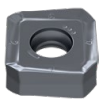

SAKU 17

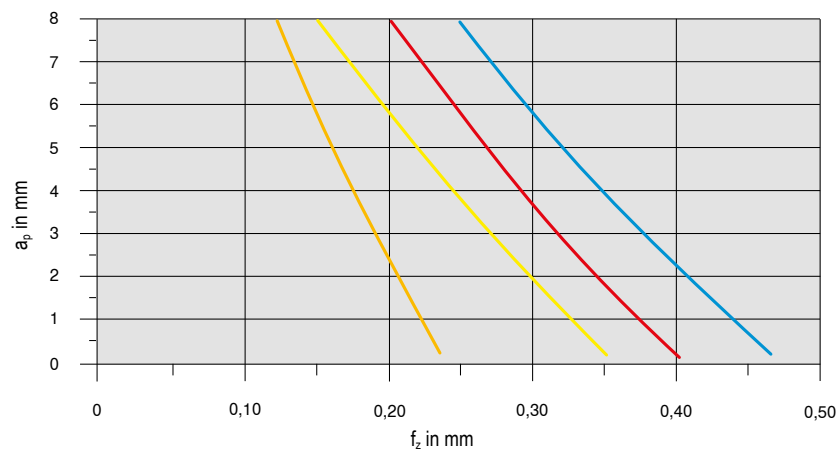

Material	Material	Material	Inserts	Inserts	vc in m/min	Cooling
Steel	P.2.2	40CrMnMoS 8-6	SAKU 1706ABSR-M50	CTPP235	200	Dry
Stainless steel	M.1.1	X6CrNiMoTi 1712 2	SAKU 1706ABSR-F50	CTPM240	180	Dry
Cast iron	K.1.1	EN-GJL-250 (GG25)	SAKU 1706ABSR-R50	CTCK215	250	Dry
Heat-resistant	S.2.2	Inconel 718	SAKU 1706ABSR-F50	CTC5240	35	Emulsion

Detailed information on cutting speed for each grade can be found on → page 146–148
From $v_c > 400$ m/min, the tool must be balanced!

MaxiMill 273-06 system

Starting Parameter



OAKU 06

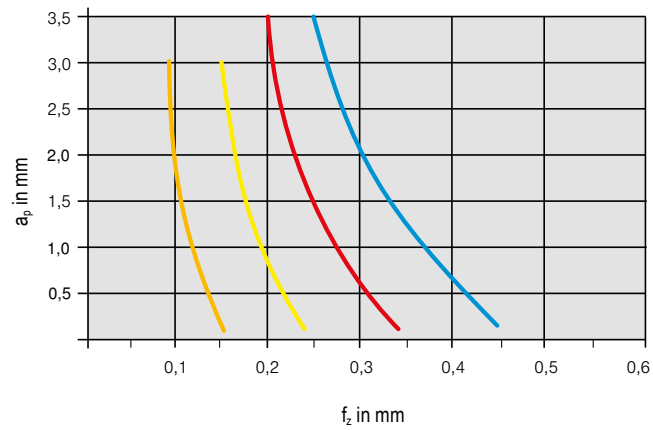

Material			Inserts		v_c in m/min	Cooling
Steel	P.2.2	40CrMnMoS 8-6	OAKU 060508SR-M50	CTPP235	200	Dry
Stainless steel	M.1.1	X6CrNiMoTi 1712 2	OAKU 060508SR-F50	CTPM240	180	Dry
Cast iron	K.1.1	EN-GJL-250 (GG25)	OAKU 060508SR-R50	CTCK215	250	Dry
Heat-resistant	S.2.2	Inconel 718	OAKU 060508ER-F40	CTC5240	35	Emulsion

 Detailed information on cutting speed for each grade can be found on → page 146–148

From $v_c > 400$ m/min, the tool must be balanced!

MaxiMill 273-08 system

Starting Parameter

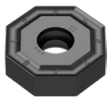

ONKU 08

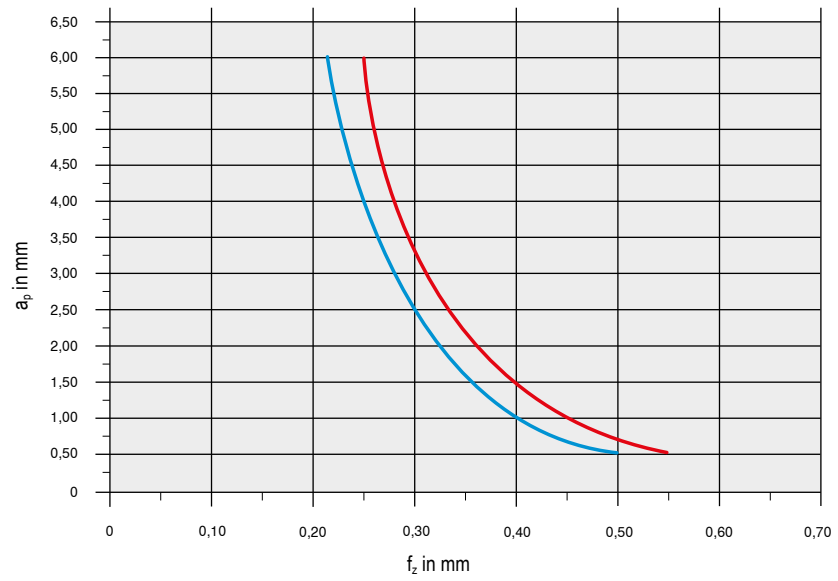

Material			Inserts		v _c in m/min	Cooling
Steel	P.2.2	40CrMnMoS 8-6	ONKU 080608SR-M50	CTPP235	180	Dry
Cast iron	K.1.1	EN-GJL-250 (GG25)	ONKU 080608SR-R50	CTCK215	250	Dry

 Detailed information on cutting speed for each grade can be found on → page 146–148

From v_c > 400 m/min, the tool must be balanced!

MaxiMill 270 system

Machining strategy

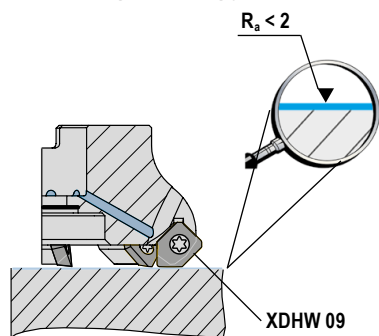

Finish milling with trailing edge inserts

Two Masterfinish inserts are mounted in each 125mm head



Steel	SDNT 0903AESN-29	CTPP235	+	XDHW 0903AESN	CTPP235
	SDNT 0903AESN-29	CTCP230	+	XDHW 0903AESN	CTCP230
	SDHT 0903AESN-33	CTCP230	+	XDHW 0903AESN	CTCP230
	SDHW 0903AESN	TCM10	+	XDHW 0903AESN	TCM10
Cast iron	SDNT 0903AESN-31	CTCK215	+	XDHW 0903AEEN	CTCK215
Non-ferrous metals	SDHT 0903AEFN-ALP	-27P H216T	+	XDHW 0903AEFN	-27P H216T

Helical plunging (without pilot hole)

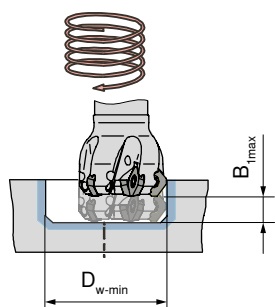

C 270-09

DC mm	D _{w-min} mm	B _{1max} mm	D _{w-max} mm	B _{2max} mm
6	14,4	1,5	19,0	1,5
12	28,5	1,5	31,0	1,5
16	36,5	1,5	39,0	1,5
20	44,5	1,5	47,0	1,5
25	54,5	1,5	57,0	1,5
32	68,5	1,5	71,0	1,5

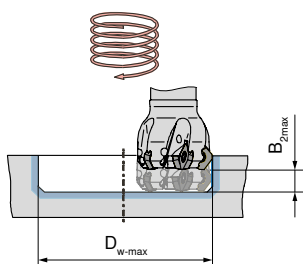

A 270-09

DC mm	D _{w-min} mm	B _{1max} mm	D _{w-max} mm	B _{2max} mm
32	68,5	1,5	71,0	1,5
40	84,5	1,5	87,0	1,5
50	104,5	1,5	107,0	1,5
63	130,5	1,5	133,0	1,5
80	164,5	1,5	167,0	1,5
100	204,5	1,5	207,0	1,5
125	254,5	1,5	257,0	1,5
160	324,5	1,5	327,0	1,5

System MaxiMill 270-12

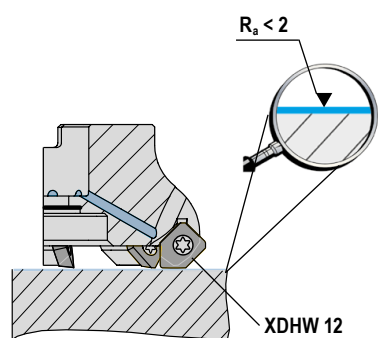

Finish milling with trailing edge inserts

Two Masterfinish inserts are mounted in each 125mm head



Steel	SDMT 1204AESN-29R	CTPP235	+	XDHW 1204AESN	CTPP235
	SDMT 1204AESN-29R	CTCP230	+	XDHW 1204AESN	CTCP230
	SDHW 1204AESN-R	TCM10	+	XDHW 1204AESN	TCM10
Cast iron	SDMT 1204AEEN-31	CTCK215	+	XDHW 1204AEEN	CTCK215
	SDHW 1204AESN-R	CTCK215	+	XDHW 1204AEEN	CTCK215
Non-ferrous metals	SDHT 1204AEFN-ALP	-27P H216T	+	XDHW 1204AEFN	-27P H216T

Helical plunging (without pilot hole)

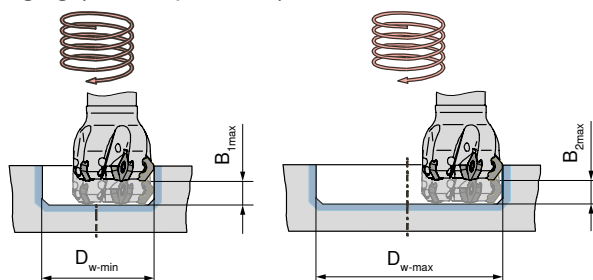

DC mm	D _{w-min} mm	B _{1max} mm	D _{w-max} mm	B _{2max} mm
32	74,5	1,5	78,0	1,5
40	90,5	1,5	94,0	1,5
50	110,5	1,5	114,0	1,5
63	136,5	1,5	140,0	1,5
80	170,5	1,5	174,0	1,5
100	210,5	1,5	214,0	1,5
125	260,5	1,5	264,0	1,5
160	330,5	1,5	334,0	1,5



From v_c > 400 m/min, the tool must be balanced!

MaxiMill HEC 11 / HEC 12 system

4 cutting edges per installation position

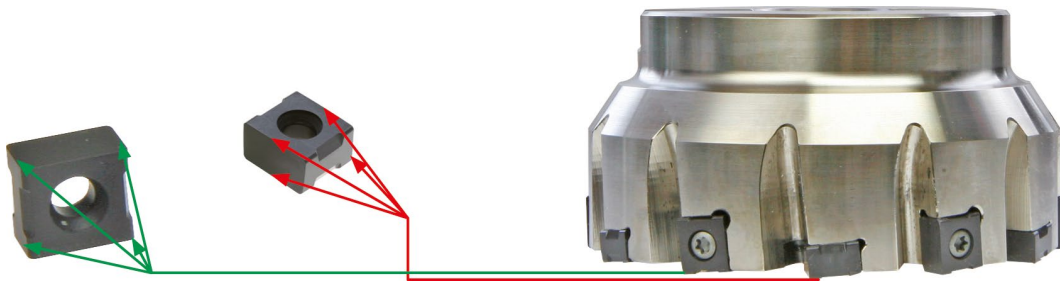

Correct assembly of standard and trailing edge inserts

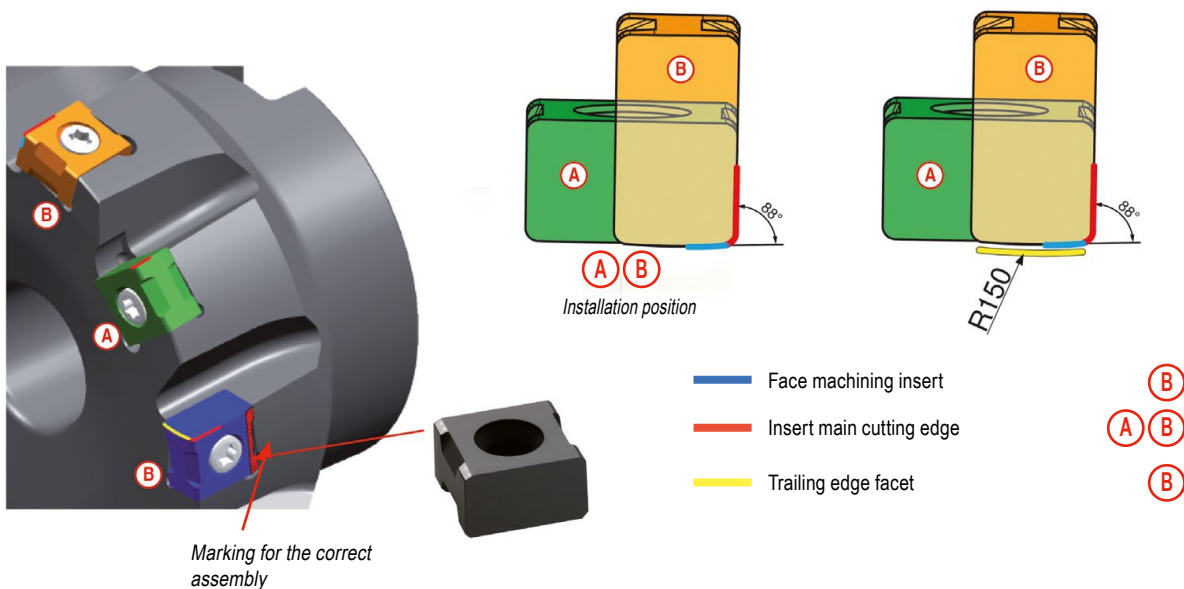

Adjust the tools in axial direction

- ▲ Install the wedge into the cutter body and lightly clamp the clamping screw so as not to clamp.
- ▲ Install the inserts as shown and tighten to 1,0 Nm torque.
- ▲ Using pre-setting equipment, mark the highest cutting edge.
- ▲ With small adjustments of the setting screw set all cutting edges to the same height by 0,005 mm or better.
- ▲ Clamp insert with 3,2 Nm torque.

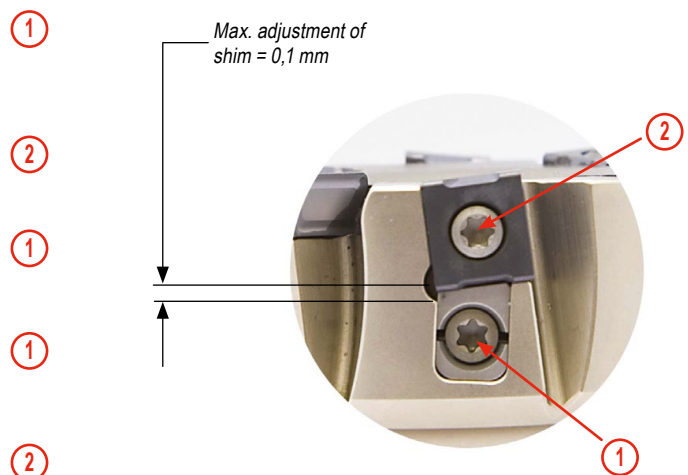

Average chip thickness [h_m] – the approach

Face milling

1 Select appropriate average chip thickness [h_m] for the steel from the table.

Material	Tensile strength N/mm ²	h _m mm
for steel	...–800	0,2
for steel	800–1000	0,18
for steel	1000–1200	0,16
for steel	1200–...	0,14
for stainless steel	... –750	0,21
for stainless steel	750–900	0,19
for stainless steel	900–1150	0,17
for stainless steel	1150– ...	0,15

2 Select the corrected feed rate value from the table based on the appropriate chip thickness [h_m] and depth of cut [a_e].

h _m mm	Corrected feed value f _z for h _m			
	0,3 x DC	0,4 x DC	0,75 x DC	1 x DC
0,20	0,40 **	0,40 **	0,33	0,28
0,18	0,40 **	0,40 **	0,29	0,25
0,16	0,40 **	0,36	0,26	0,23
0,14	0,36	0,31	0,23	0,20
0,21	0,40 **	0,40 **	0,34	0,30
0,19	0,40 **	0,40 **	0,31	0,27
0,17	0,40 **	0,38	0,28	0,24
0,15	0,39	0,34	0,24	0,21
a _e =	0,3 x DC	0,4 x DC	0,75 x DC	1 x DC

** f_z > 0,4 mm: Danger of an open space contact

MaxiMill 491-09 system

Starting Parameter



SNHU 09

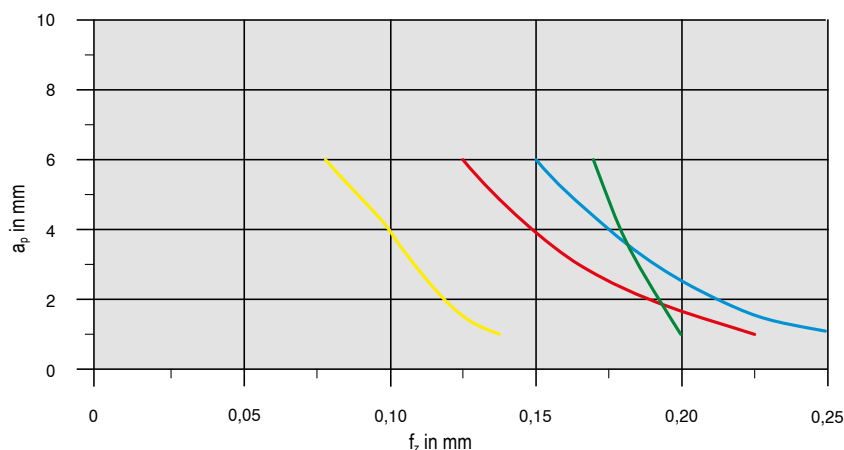

Material			Inserts		v_c in m/min	Cooling
Steel	P.2.2	40CrMnMoS 8-6	SNHU09T308SR-M50	CTPP235	200	Dry
Stainless steel	M.1.1	X6CrNiMoTi 1712 2	SNHU09T308SR-F50	CTPM240	180	Emulsion
Cast iron	K.1.1	EN-GJL-250 (GG25)	SNHU09T308SR-R50	CTCK215	250	Dry
Non-ferrous metals	N.1.2	AlMgSi1	SNHU09T308FR-F10	CTWN215	500	Emulsion

MaxiMill 491-12 system

Starting Parameter



SNHU 12

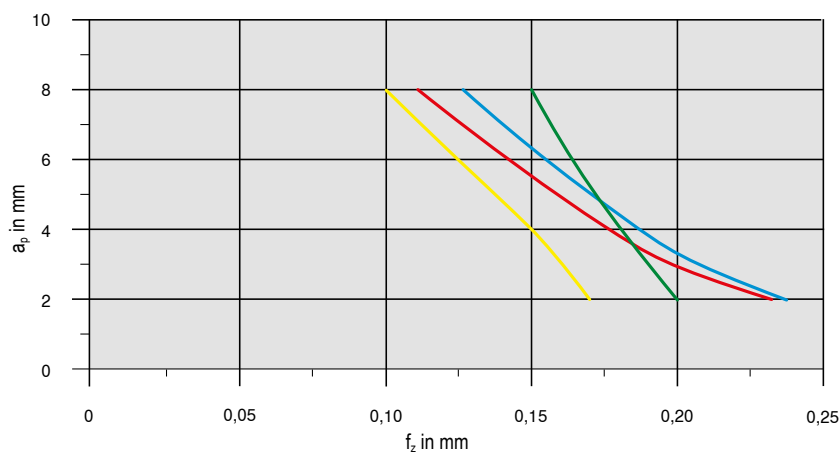

Material			Inserts		v_c in m/min	Cooling
Steel	P.2.2	40CrMnMoS 8-6	SNHU120408SR-M50	CTPP235	200	Dry
Stainless steel	M.1.1	X6CrNiMoTi 1712 2	SNHU120408SR-F50	CTPM240	180	Emulsion
Cast iron	K.1.1	EN-GJL-250 (GG25)	SNHU120408SR-R50	CTCK215	250	Dry
Non-ferrous metals	N.1.2	AlMgSi1	SNHU120408FR-F10	CTC5240	500	Emulsion

Detailed information on cutting speed for each grade can be found on → page 146–148
From $v_c > 400$ m/min, the tool must be balanced!

System MaxiMill 211-07

Machining strategy

Helical plunging

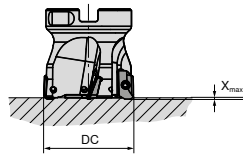
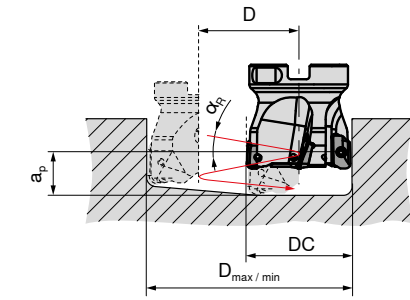

$$a_p \text{ in mm} = D * \pi * \tan \alpha_R$$

DC mm	D _{max} / RE 0,4 mm	D _{min} mm	α _{R max} °
10	19	13	5,5
12	23	17	6,0
16	31	25	3,0
20	39	33	2,0
25	49	43	1,5
32	63	57	1,2
40	79	73	0,8
50	99	93	0,7

DC mm	D mm	α _{R max 360°} °
10	13	5,5
12	17	6,0
16	25	3,0
20	33	2,0
25	43	1,5
32	57	1,2
40	73	0,8
50	93	0,7

Axial ramping

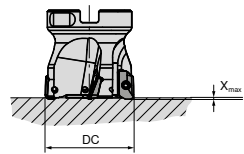

DC mm	X _{max} mm
10	0,8
12	0,8
16	0,8
20	0,8
25	0,8
32	0,8
40	0,8
50	0,8

D_{max} in mm = largest diameter for flat bottom hole
D_{min} in mm = smallest hole diameter for flat bottom surface

Angled ramping

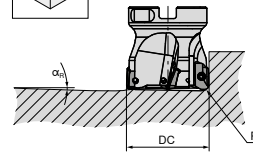

DC mm	α °
10	11,0
12	7,9
16	4,3
20	3,0
25	2,5
32	1,6
40	1,2
50	1,0

$$D = D_{max} - DC / D_{min} - DC$$

Starting Parameter

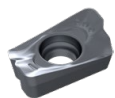

XDKT 07

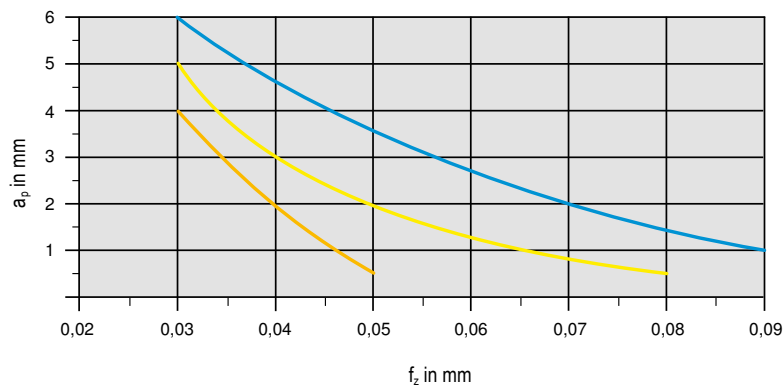

Material		Material	Inserts	v _c in m/min	Cooling
Steel	P.2.2	40CrMnMoS 8-6	XDKT070308SR-M50 CTCP230	200	Dry
Stainless steel	M.1.1	X6CrNiMoTi 1712 2	XDKT070308SR-F50 CTPM240	180	Dry
Heat-resistant	S.2.2	Inconel 718	XDKT070308ER-F50 CTC5240	35	Emulsion



Detailed information on cutting speed for each grade can be found on → page 146–148

From v_c > 400 m/min, the tool must be balanced!

System MaxiMill 211-11

Machining strategy

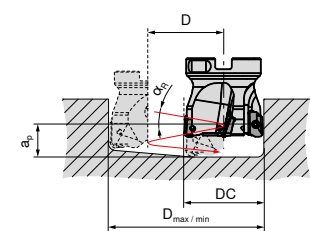

① Helical plunging

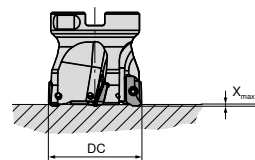

② Axial ramping

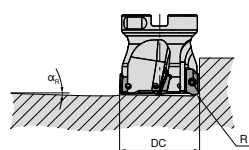

③ Angled ramping



DC mm	Maximum speed related to projection length				
	$l_a = 1-2 \times \varnothing$ mm	$l_a = 2,5 \times \varnothing$ mm	$l_a = 3 \times \varnothing$ mm	$l_a = 4 \times \varnothing$ mm	$l_a = 5 \times \varnothing$ mm
12	55000	51500	47000	42000	37000
16	42000	38500	34100	28900	24200
20	36900	33000	28500	23900	19500
25	33200	29000	24400	19900	15400
32	30200	26000	20900	16600	11900
40	27700	23000	18000	13500	9000
50	25400	20400	15400	10800	6100
63	23300	18300	12900	8300	3700
80	21300	16100	10600	5800	
100	19600	14100	8400		
125	17900	12800	7600		

DC mm	① Helical plunging			② Axial ramping	③ Angled ramping
	RE = 0,8 mm			X_{max}	α_R
12	α_R	16 °		1,3 mm	18 °
	$D_{max.}$	21 mm			
	$D_{min.}$	14 mm			
16	α_R	9,5 °		1,5 mm	10,8 °
	$D_{max.}$	29 mm			
	$D_{min.}$	21 mm			
20	α_R	7 °		2,0 mm	9,8 °
	$D_{max.}$	37 mm			
	$D_{min.}$	30 mm			
25	α_R	4,5 °		2,0 mm	7,5 °
	$D_{max.}$	47 mm			
	$D_{min.}$	40 mm			
32	α_R	3,2 °		1,0 mm	4,8 °
	$D_{max.}$	61 mm			
	$D_{min.}$	53 mm			
40	α_R	2,2 °		1,6 mm	2,9 °
	$D_{max.}$	77 mm			
	$D_{min.}$	72 mm			
50	α_R	1,7 °		1,6 mm	2,2 °
	$D_{max.}$	98 mm			
	$D_{min.}$	93 mm			
63	α_R	1,5 °		1,6 mm	1,8 °
	$D_{max.}$	123 mm			
	$D_{min.}$	116 mm			
80	α_R	1,0 °		1,6 mm	1,4 °
	$D_{max.}$	157 mm			
	$D_{min.}$	153 mm			
100	α_R	0,8 °		1,6 mm	1,1 °
	$D_{max.}$	197 mm			
	$D_{min.}$	193 mm			
125	α_R	0,6 °		1,6 mm	0,8 °
	$D_{max.}$	247 mm			
	$D_{min.}$	243 mm			

$D_{max.}$ in mm = largest diameter for flat bottom hole

$D_{min.}$ in mm = Smallest diameter for flat bottom surface

a_p in mm = $D \times \pi \times \tan(\alpha_R) =$ Pitch

l_a in mm = Overhang length

Starting Parameter

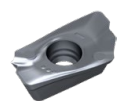

XDKT 11

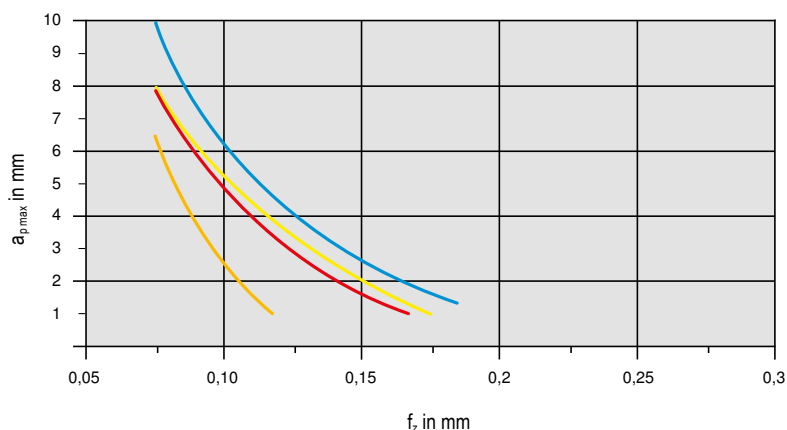

Material	Inserts		v_c in m/min	Cooling
Steel	P.2.2 40CrMnMoS 8-6	XDKT11T308SR-M50 CTCP230	200	Dry
Stainless steel	M.1.1 X6CrNiMoTi 1712 2	XDKT11T308SR-F50 CTPM240	180	Dry
Cast iron	K.1.1 EN-GJL-250 (GG25)	XDKT11T308SR-R50 CTCK215	250	Dry
Heat-resistant	S.2.2 Inconel 718	XDKT11T308ER-F50 CTC5240	35	Emulsion

① Detailed information on cutting speed for each grade can be found on → page 146–148

From $v_c > 400$ m/min, the tool must be balanced!

System MaxiMill 211-15

Machining strategy

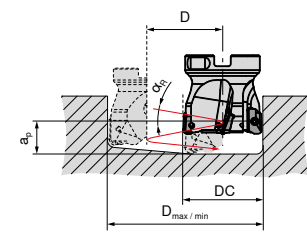

① Helical plunging

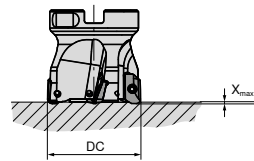

② Axial ramping

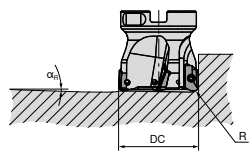

③ Angled ramping



DC mm	Maximum speed related to projection length		
	$l_a = 2 \times \varnothing$ mm	$l_a = 3 \times \varnothing$ mm	$l_a = 5 \times \varnothing$ mm
25	26560	19520	13320
32	24160	16720	9520
40	22160	14400	7200
50	20320	12320	4880
63	18640	10320	2960
80	17040	8480	
100	15680	6720	
125	14320		
160	13200		

DC mm	① Helical plunging		② Axial ramping	③ Angled ramping
	RE = 0,8 mm		X_{max}	α_R
25	α_R	7,5 °		
	$D_{max.}$	48 mm	2,7 mm	9,5 °
	$D_{min.}$	37 mm		
32	α_R	5 °	2,5 mm	6,8 °
	$D_{max.}$	62 mm		
	$D_{min.}$	47 mm		
40	α_R	3,2 °	2,5 mm	5,1 °
	$D_{max.}$	78 mm		
	$D_{min.}$	63 mm		
50	α_R	2,5 °	2,5 mm	2,5 °
	$D_{max.}$	98 mm		
	$D_{min.}$	86 mm		
63	α_R	1,5 °	2,5 mm	2,5 °
	$D_{max.}$	124 mm		
	$D_{min.}$	111 mm		
80	α_R	1,3 °	2,5 mm	2,0 °
	$D_{max.}$	158 mm		
	$D_{min.}$	147 mm		
100	α_R	1,1 °	2,5 mm	1,5 °
	$D_{max.}$	198 mm		
	$D_{min.}$	190 mm		
125	α_R	0,9 °	2,5 mm	0,9 °
	$D_{max.}$	248 mm		
	$D_{min.}$	240 mm		
160	α_R	0,6 °	2,5 mm	0,7 °
	$D_{max.}$	318 mm		
	$D_{min.}$	310 mm		

$D_{max.}$ in mm = largest diameter for flat bottom hole
 $D_{min.}$ in mm = Smallest diameter for flat bottom surface
 a_p in mm = $D \times \pi \times \tan(\alpha_R) =$ Pitch
 l_a in mm = Overhang length

Starting Parameter

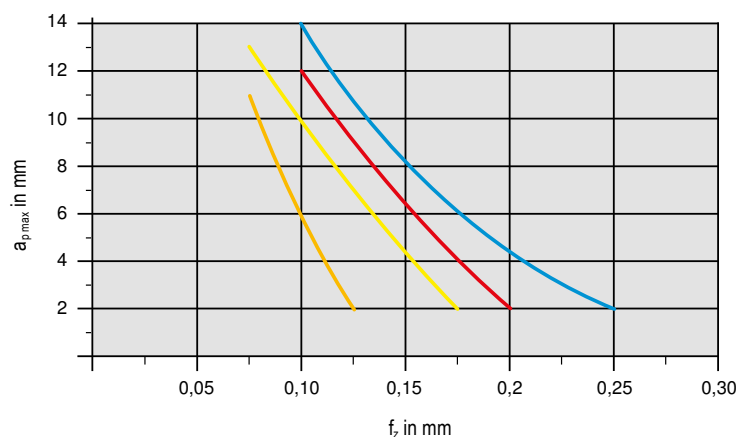

Material	Inserts		v_c in m/min	Cooling
Steel	P.2.2 40CrMnMoS 8-6	XDKT150508SR-M50 CTCP230	200	Dry
Stainless steel	M.1.1 X6CrNiMoTi 1712 2	XDKT150508SR-F50 CTPM240	180	Dry
Cast iron	K.1.1 EN-GJL-250 (GG25)	XDKT150508SR-R50 CTCK215	250	Dry
Heat-resistant	S.2.2 Inconel 718	XDKT150508ER-F40 CTC5240	35	Emulsion

① Detailed information on cutting speed for each grade can be found on → page 146–148
 From $v_c > 400$ m/min, the tool must be balanced!

System MaxiMill 211-20

Machining strategy

Helical plunging

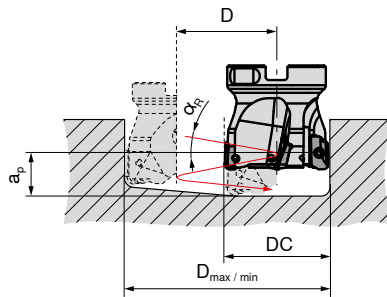

DC mm	D _{max} / RE 0,4 mm	D _{min} mm	α _{R max} °
63	124	107	2,2
80	158	143	1,7
100	198	183	1,3

$$a_p \text{ in mm} = D * \pi * \tan \alpha_R$$

Axial ramping

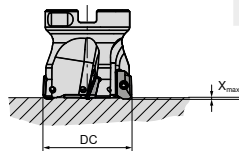

DC mm	X _{max} mm
63	2,0
80	2,0
100	2,0

Angled ramping

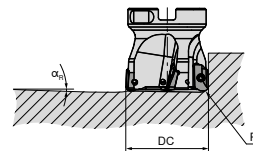

DC mm	α °
63	2,2
80	1,7
100	1,3

$$D = D_{max} - DC / D_{min} - DC$$

D_{max} in mm = largest diameter for flat bottom hole

D_{min} in mm = smallest hole diameter for flat bottom surface

Starting Parameter

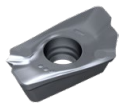

XDKT 20

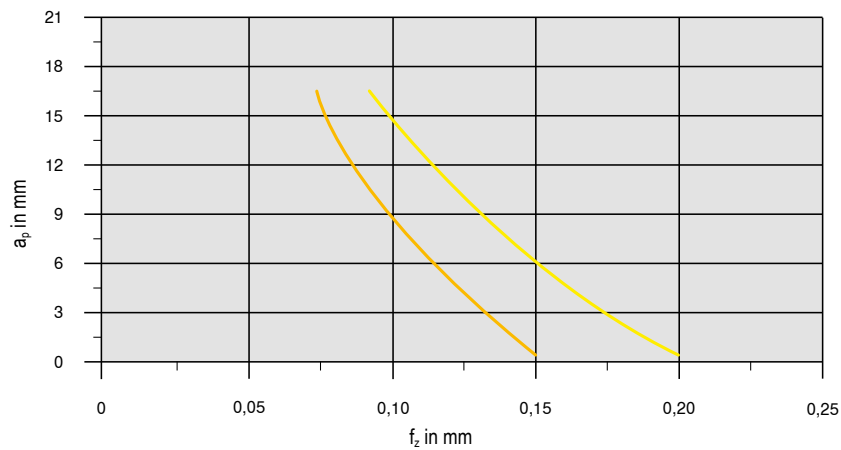

Material			Inserts		v _c in m/min	Cooling
Stainless steel	M.1.1	X6CrNiMoTi 1712 2	XDKT200708ER-F40	CTPM240	180	Dry
Heat-resistant	S.2.2	Inconel 718	XDKT200708ER-F40	CTC5240	35	Emulsion

Detailed information on cutting speed for each grade can be found on → page 146–148
From v_c > 400 m/min, the tool must be balanced!

System MaxiMill 490-09

Machining strategy

i System MaxiMill 490-09 is not suitable for plunging!

Starting Parameter



SDNT 09

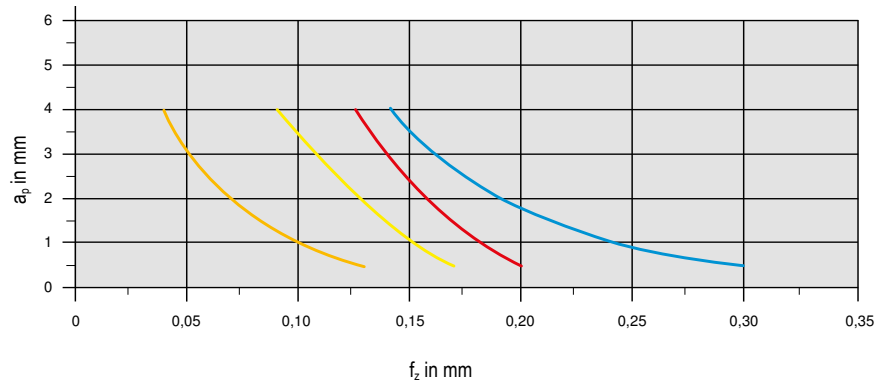

Material			Inserts		v_c in m/min	Cooling
Steel	P.2.2	40CrMnMoS 8-6	SDNT09T308SR-29	CTCP230	200	Dry
Stainless steel	M.1.1	X6CrNiMoTi 1712 2	SDNT09T308SR-33	CTPM240	180	Dry
Cast iron	K.1.1	EN-GJL-250 (GG25)	SDNT09T308SR-31	CTCK215	250	Dry
Heat-resistant	S.2.2	Inconel 718	SDNT09T308ER-M31	CTC5240	35	Emulsion

i Detailed information on cutting speed for each grade can be found on → page 146–148

MaxiMill 490-09 adjustable angle milling cutter – dimensions

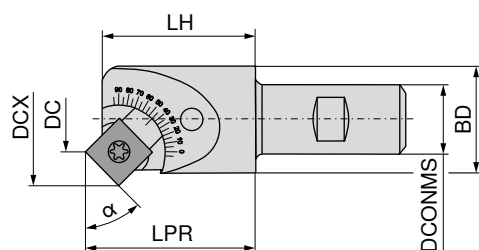

Constant dimensions			Angle-dependent dimensions*			
BD	DCONMS	LH	α	DC*	DCX	LPR*
18,6	16	32	0°	9,35/1,60**	20,14	33,07
			5°	3,81	20,82	33,40
			10°	4,59	21,44	33,69
			15°	5,42	21,98	33,95
			20°	6,30	22,45	34,17
			25°	7,23	22,85	34,35
			30°	8,18	23,16	34,49
			35°	9,15	23,39	34,58
			40°	10,14	23,53	34,64
			45°	11,13	23,59	34,65
			50°	12,12	23,56	34,61
			55°	13,09	23,44	34,54
			60°	14,04	23,24	34,42
			65°	14,96	22,96	34,26
			70°	15,84	22,60	34,06
			75°	16,68	22,16	33,83
			80°	17,46	21,65	33,56
			85°	18,19	21,07	33,25
			90°	10,07/1,90**	20,44	32,93

* Tangential cutting point at deepest engagement point

** Smallest diameter in centre

System MaxiMill 490-12

Machining strategy

Helical plunging (without pilot hole)

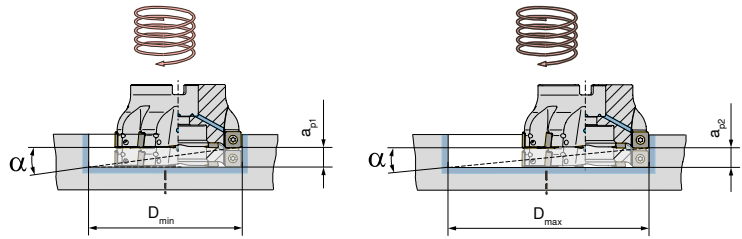

$$B = (D_w - DC) \times \pi \times \tan \alpha$$

D_w = Diameter of the hole to be produced
 DC = Nominal diameter of the milling tool
 B = Axial feed to 360° circular movement

DC mm	D_{min} mm	a_{p1} mm	D_{max} mm	a_{p2} mm	α °
50	77	2,5	98	4,8	2,0
63	103	1,8	124	3,0	1,0
80	137	2,1	158	3,0	0,8
100	177	2,1	198	2,9	0,6
125	227	1,8	248	2,4	0,4

Starting Parameter



SDMT 12

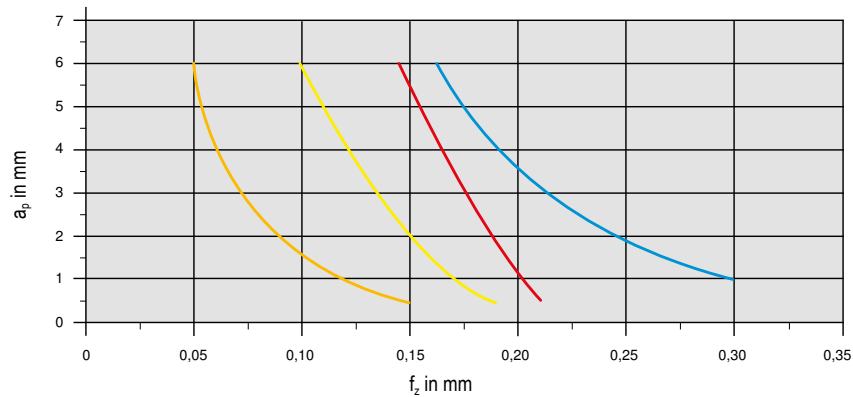

Material			Inserts	v_c in m/min	Cooling
Steel	P.2.2	40CrMnMoS 8-6	SDMT1205ZZSN-29 CTCP230	200	Dry
Stainless steel	M.1.1	X6CrNiMoTi 1712 2	SDMT120512SR-33 CTPM240	180	Dry
Cast iron	K.1.1	EN-GJL-250 (GG25)	SDMT1205ZZSN-31 CTCK215	250	Dry
Heat-resistant	S.2.2	Inconel 718	SDMT120508ER-M31 CTC5240	35	Emulsion

Detailed information on cutting speed for each grade can be found on → page 146–148

MaxiMill 490-12 adjustable angle milling cutter – dimensions

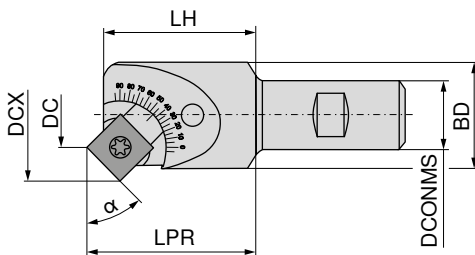

Constant dimensions			Angle-dependent dimensions*			
BD	DCONMS	LH	α	DC*	DCX	LPR*
25	20	37	0°	25,07/1,12**	26,64	38,36
			5°	3,72	27,61	38,79
			10°	4,84	28,48	39,21
			15°	6,03	29,25	39,58
			20°	7,27	29,92	39,90
			25°	8,57	30,48	40,16
			30°	9,91	30,92	40,37
			35°	11,28	31,25	40,51
			40°	12,67	31,45	40,60
			45°	14,08	31,54	40,62
			50°	15,48	31,50	40,58
			55°	16,86	31,34	40,48
			60°	18,23	31,06	40,33
			65°	19,56	30,66	40,11
			70°	20,85	30,15	39,83
			75°	22,08	29,52	39,51
			80°	23,26	28,79	39,12
			85°	24,35	27,95	38,69
			90°	25,37/1,42**	26,94	38,21

* Tangential cutting point at deepest engagement point
 ** Smallest diameter in centre

HSC/HPC machining

Safety advice

Suitability of the tool for HSC machining

HSC tools from CERATIZIT have been specially developed for this machining strategy and guarantee maximum operational reliability.

Observation of safety precautions of the machine manufacturer

Make sure that all safety precautions of the machine-manufacturer are observed (e.g.: closed machine guards).

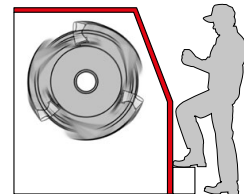

Suitability of the adapters for HSC machining

According to the milling situation, choose the optimum tool/clamping device combination. For high speed milling applications it is necessary to dynamically balance tool and tool adapter together (see ISO 1940 directives).

Mounting the indexable insert with centrifugal force protection

Insert clamping: EURO-patent EP 1083017A1

Make sure that the insert pocket is cleaned and the threading bore for the clamping screw is in good condition.

Check the axial and radial contact points of the insert in the pocket.

The clamping screws for positive insert clamping must be tightened with a torque of (XDHT11 = 1,8 Nm; XDH.19 = 6,0 Nm).

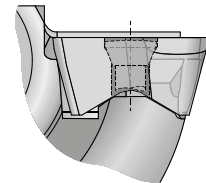

Optimum mounting of HSC milling cutters (DC = Ø 40–63) to milling arbors using power screw

The power screw guarantees a stable connection of tool and milling adapter and is easy to use.

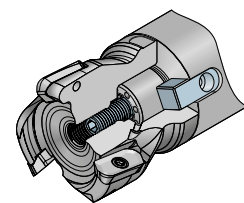

Power Screw

Maximum admissible number of revolutions

Please note the maximum number of revolutions stated on the tool. This number is exclusively valid for the specific tool and must be adapted according to the selected tool adapter, total overhang length and the respective machining situation.



Optimum application range of the tool (a_e , a_p , f_z , n)

In order to guarantee productive milling, please observe the recommendations regarding the cutting parameters.





System MaxiMill HSC-11

Cutting data standard values

Workpiece material	Treatment / alloy	VDI 3323 Group	Hardness HB	H216T (CTWN215)	
				 v_c in m/min	 v_c in m/min
Aluminum alloys	non hardenable	21	60		660-9840
	hardenable	22	100		660-6560
Cast aluminum alloy	non hardenable < 12% Si	23	80		660-6560
	hardenable < 12% Si	24	90		660-5900
	non hardenable > 12% Si	25	130		660-3280
Copper and copper alloys (Bronze, Brass)	Free-cutting steel alloy (1% Pb)	26			660-1970
	brass, red bronze	27	90	820-3280	820-3280
	bronze	28	100		490-1310
	lead-free copper and electrolytic copper	29	100		980-2620
Non metal materials	Duroplastics	29		260-3280	260-3280
	Fibre-reinforced plastics	29		230-1640	230-1640
	hard rubber	30		100-260	100-260

 = full lubricant

 = Minimum quantity lubrication

 = dry machining

System MaxiMill HSC-11

Machining strategy

Axial ramping

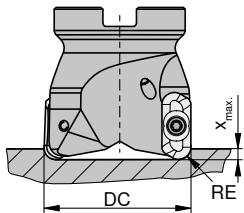

DC mm	X _{max} mm
16	1,70
18	2,11
19	2,24
20	2,39
22	2,70
25	2,55
32	2,40
40	2,28
50	2,26
63	2,10
80	1,75
100	1,79

Angled ramping

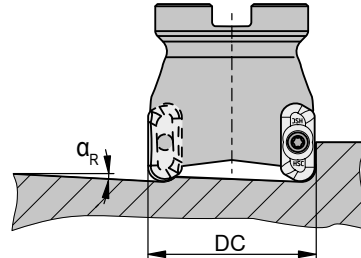

DC mm	alpha _R °
16	18,8
18	16,3
19	15,3
20	14,8
22	13,8
25	10,3
32	6,8
40	4,8
50	3,5
63	2,5
80	1,8
100	1,3

Milling strategy for roughing and finishing

With maximum chip volume

Indexable Insert	RE mm	1	2,3,4
		a _p mm	a _{p max.} mm
XDHT 11T302FR-ALP	0,2	10	9,8
XDHT 11T304FR-ALP	0,4	10	9,6
XDHT 11T308FR-ALP	0,8	10	9,2
XDHT 11T312FR-ALP	1,2	10	8,8
XDHT 11T316FR-ALP	1,6	10	8,4
XDHT 11T320FR-ALP	2,0	10	8,0
XDHT 11T325FR-ALP	2,5	10	7,5
XDHT 11T332FR-ALP	3,2	10	6,8
XDHT 11T340FR-ALP	4,0	10	6,0
XDHT 11T350FR-ALP	5,0	10	5,0

With maximum side wall quality

Indexable Insert	RE mm	2,3,4
		a _{p max.} mm
XDHT 11T302FR-ALP	0,2	7,8
XDHT 11T304FR-ALP	0,4	7,6
XDHT 11T308FR-ALP	0,8	7,2
XDHT 11T312FR-ALP	1,2	6,5
XDHT 11T316FR-ALP	1,6	6,8
XDHT 11T320FR-ALP	2,0	6,4
XDHT 11T325FR-ALP	2,5	5,5
XDHT 11T332FR-ALP	3,2	4,8
XDHT 11T340FR-ALP	4,0	4,0
XDHT 11T350FR-ALP	5,0	3,0

Shoulder milling

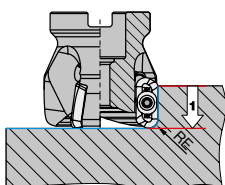

Modification to front profile

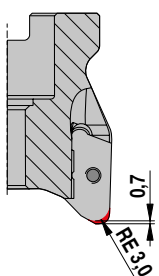

Pocket milling

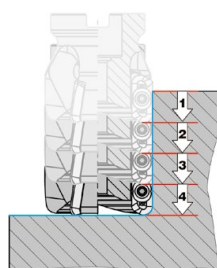

Pocket milling with thin walled components

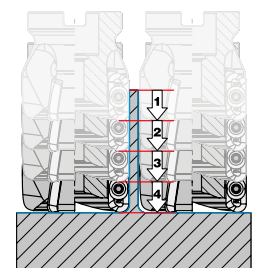

For inserts with a corner radius larger than 3.2 mm the basic body of the tool must be modified according to the drawing above.

System MaxiMill HSC-11

Machining strategy

Helical plunging

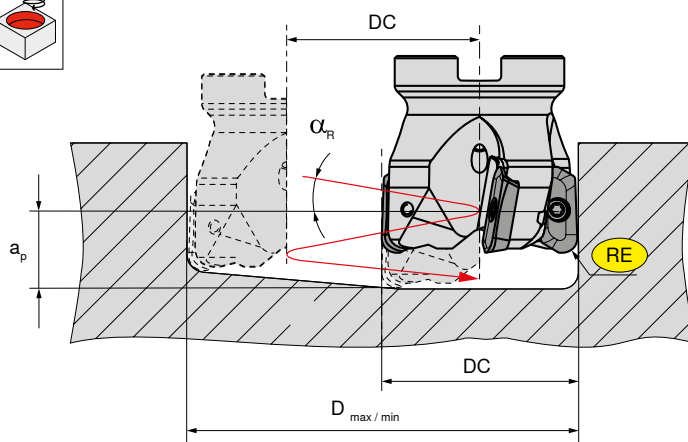

RE = Insert radius
 α_R in mm = Maximum ramping angle (related to centre of tool)

a_p in mm = $D \times \pi \times \tan(\alpha_R)$

D in mm = $\rightarrow D_{max} - DC$ and/or $D_{min} - DC$

For flat bottom hole

D_{max} in mm = largest drilling diameter
 D_{min} in mm = smallest drilling diameter
 DN_{max} in mm = Maximum hole diameter for non flat bottom

DC mm	(DN_{max})	XDHT-11 (HSC-11)								
		RE = 0,2	RE = 0,4	RE = 0,8	RE = 1,2	RE = 1,6	RE = 2,0	RE = 2,5	RE = 3,2	RE = 4,0
16	α_R	9,7°	10,0°	9,9°	9,4°	8,9°	8,4°	7,9°	7,0°	6,1°
	D_{max}	30	30	29	28	27	27	26	24	23
	D_{min}	18	18	18	18	18	18	18	18	18
18	α_R	9,4°	9,1°	8,7°	8,3°	7,9°	7,5°	6,9°	6,2°	5,3°
	D_{max}	34	34	33	32	31	31	30	28	27
	D_{min}	22	22	22	22	22	22	22	22	22
19	α_R	8,8°	8,6°	8,3°	7,9°	7,5°	7,5°	6,5°	5,9°	5,1°
	D_{max}	36	36	35	34	33	33	32	30	29
	D_{min}	24	24	24	24	24	24	24	24	24
20	α_R	8,4°	8,2°	7,8°	7,4°	7,7°	6,7°	6,2°	5,5°	4,8°
	D_{max}	38	38	37	36	35	35	34	32	31
	D_{min}	26	26	26	26	26	26	26	26	26
22	α_R	7,6°	7,4°	7,8°	6,7°	6,4°	6,5°	5,6°	5,2°	4,3°
	D_{max}	42	42	41	40	39	39	38	36	35
	D_{min}	30	30	30	30	30	30	30	30	30
25	α_R	6,7°	6,5°	6,2°	5,9°	5,6°	5,3°	4,9°	4,4°	3,8°
	D_{max}	48	48	47	46	45	45	44	42	41
	D_{min}	36	36	36	36	36	36	36	36	36
32	α_R	4,7°	4,7°	4,8°	4,6°	4,3°	4,1°	3,8°	3,4°	2,9°
	D_{max}	62	62	61	60	59	59	58	56	55
	D_{min}	50	50	50	50	50	50	50	50	50
40	α_R	3,3°	3,3°	3,4°	3,4°	3,5°	3,3°	3,0°	2,7°	2,3°
	D_{max}	78	78	77	76	75	75	74	72	71
	D_{min}	66	66	66	66	66	66	66	66	66
50	α_R	2,4°	2,5°	2,5°	2,5°	2,6°	2,6°	2,4°	2,2°	1,9°
	D_{max}	98	98	97	96	95	95	94	92	91
	D_{min}	86	86	86	86	86	86	86	86	86
63	α_R	1,7°	1,7°	1,7°	1,8°	1,8°	1,8°	1,8°	1,7°	1,5°
	D_{max}	124	124	123	122	121	121	120	118	117
	D_{min}	112	112	112	112	112	112	112	112	112
80	α_R	1,1°	1,1°	1,1°	1,1°	1,1°	1,1°	1,1°	1,2°	1,2°
	D_{max}	158	158	157	156	155	155	154	152	151
	D_{min}	146	146	146	146	146	146	146	146	146
100	α_R	0,8°	0,8°	0,9°	0,9°	0,9°	0,9°	0,9°	0,9°	0,9°
	D_{max}	198	198	197	196	195	195	194	192	191
	D_{min}	186	186	186	186	186	186	186	186	186

System MaxiMill HSC/HPC-19

Machining strategy

Helical plunging

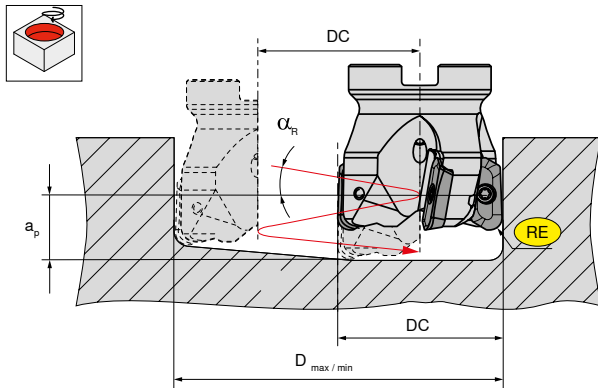

RE = Insert radius
 α_R in mm = Maximum ramping angle (related to centre of tool)

a_p in mm = pitch $\rightarrow D \times \pi \times \tan(\alpha_R)$

D in mm = $\rightarrow D_{max} - DC$ and/or $D_{min} - DC$

For flat bottom hole

D_{max} in mm = largest drilling diameter
 D_{min} in mm = smallest drilling diameter
 DN_{max} in mm = Maximum hole diameter for non flat bottom

	DC mm	DN_{max} mm	α_R	D_{max} mm	D_{min} mm
RE = 0,2 mm	25	49	7°02'	48	32
	32	63	4°34'	62	46
	40	79	3°47'	78	62
	50	99	3°01'	97	81
	63	125	2°17'	124	107
	80	159		158	141
	100	199		198	181

	DC mm	DN_{max} mm	α_R	D_{max} mm	D_{min} mm
RE = 0,4 mm	25	49	7°08'	48	32
	32	63	4°37'	62	46
	40	79	3°49'	78	62
	50	99	3°02'	98	81
	63	125	2°18'	124	107
	80	159		158	141
	100	199		198	181

	DC mm	DN_{max} mm	α_R	D_{max} mm	D_{min} mm
RE = 0,8 mm	25	49	7°21'	47	32
	32	63	4°44'	61	46
	40	79	3°53'	77	62
	50	99	3°05'	97	81
	63	125	2°20'	123	107
	80	159		157	141
	100	199		197	181

	DC mm	DN_{max} mm	α_R	D_{max} mm	D_{min} mm
RE = 2,0 mm	25	49	8°40'	45	32
	32	63	5°04'	59	46
	40	79	4°06'	75	62
	50	99	3°13'	95	81
	63	125	2°25'	121	107
	80	159		155	141
	100	199		195	181

	DC mm	DN_{max} mm	α_R	D_{max} mm	D_{min} mm
RE = 2,5 mm	25	49	8°24'	44	32
	32	63	5°13'	58	46
	40	79	4°12'	74	62
	50	99	3°17'	94	81
	63	125	2°27'	120	107
	80	159		154	141
	100	199		194	181

	DC mm	DN_{max} mm	α_R	D_{max} mm	D_{min} mm
RE = 3,2 mm	25	49	8°54'	42	32
	32	63	5°26'	56	46
	40	79	4°20'	72	62
	50	99	3°21'	92	81
	63	125	2°30'	118	107
	80	159		152	141
	100	199		192	181

	DC mm	DN_{max} mm	α_R	D_{max} mm	D_{min} mm
RE = 4,0 mm	25	49	9°32'	41	32
	32	63	5°42'	55	46
	40	79	4°30'	71	62
	50	99	3°28'	91	81
	63	125	2°33'	117	107
	80	159		151	141
	100	199		191	181

	DC mm	DN_{max} mm	α_R	D_{max} mm	D_{min} mm
RE = 5,0 mm	25	49	6°49'	39	32
	32	63	3°59'	53	46
	40	79	3°20'	69	62
	50	99	2°13'	89	81
	63	125	1°52'	115	107
	80	159		149	141
	100	199		189	181

System MaxiMill HSC/HPC-19

Machining strategy

Axial ramping

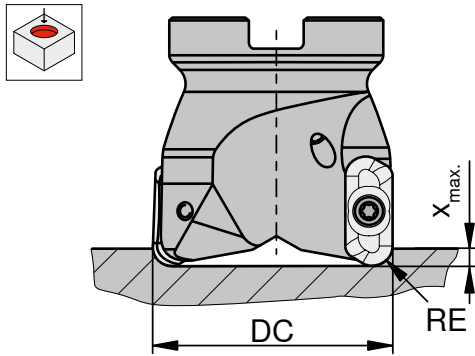

HSC 19	DC mm	19 RE 0,2-4,0	19 RE 5,0
		X _{max} mm	X _{max} mm
CHSC 19 / GHSC 19 / MHSC 19	25	5,0	4,0
CHSC 19 / GHSC 19 / MHSC 19	32-40	4,0	3,0
AHSC 19	40-100	4,0	3,0

HPC 19	DC mm	19 RE 0,2-4,0	19 RE 5,0
		X _{max} mm	X _{max} mm
CHPC 19 / MHPC 19	22-25	5,0	4,0
CHPC 19 / MHPC 19	32-50	6,0	5,0
AHPC 19	40-63	6,0	5,0

Angled ramping

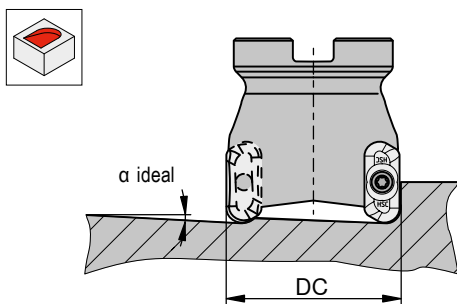

DC mm	α ideal	
	HSC 19	HPC 19
25	11°	11°
32	7°	7°
40	5°	5°
50	4°	4°
63	3°	3°
80	2°	
100	2°	

Modification to basic body

HSC 19

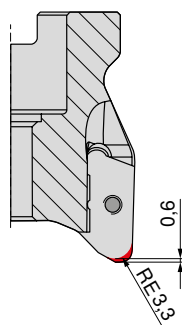
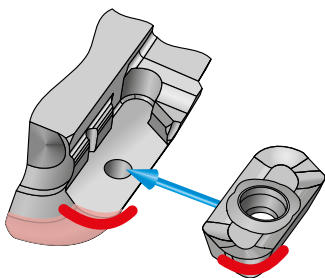

HPC 19

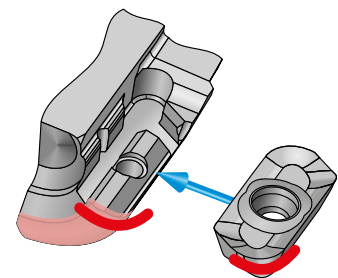

Modification to front profile

For inserts with a corner radius larger than 4.0 mm the basic body of the tool must be modified according to the drawing above.



System MaxiMill HSC/HPC-19

Machining strategy

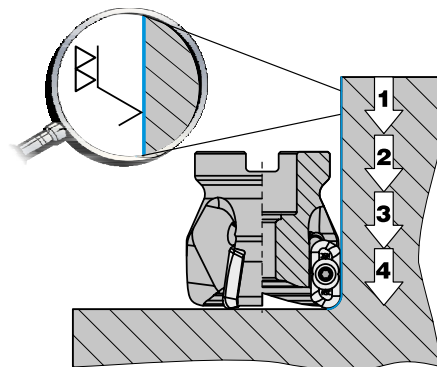
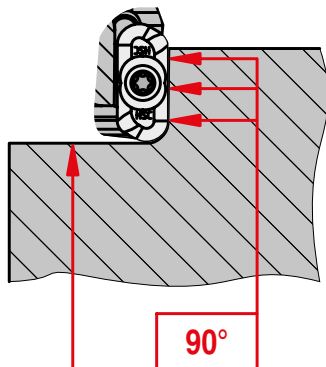

 Excellent side wall quality after roughing operation.
Additional finishing operations minimized or no longer required.



With maximum chip volume

Indexable Insert			
	RE mm	a _p mm	a _{p max.} mm
XDH. 190402FR-ALP	0,2	18,0	17,8
XDH. 190404FR-ALP	0,4	18,0	17,6
XDH. 190408FR-ALP	0,8	18,0	17,2
XDH. 190420FR-ALP	2,0	18,0	16,0
XDH. 190425FR-ALP	2,5	18,0	15,0
XDH. 190432FR-ALP	3,2	18,0	14,8
XDH. 190440FR-ALP	4,0	18,0	14,0
XDH. 190450FR-ALP	5,0	17,0	13,0

With maximum side wall quality

Indexable Insert		
	RE mm	a _{p max.} mm
XDH. 190402FR-ALP	0,2	11,8
XDH. 190404FR-ALP	0,4	11,6
XDH. 190408FR-ALP	0,8	11,2
XDH. 190420FR-ALP	2,0	10,0
XDH. 190425FR-ALP	2,5	9,5
XDH. 190432FR-ALP	3,2	8,8
XDH. 190440FR-ALP	4,0	8,0
XDH. 190450FR-ALP	5,0	7,0

Shoulder milling

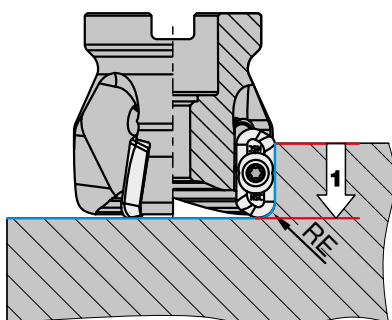

Pocket milling

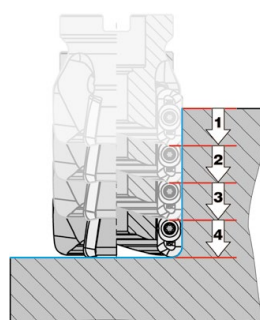

Pocket milling with thin walled components

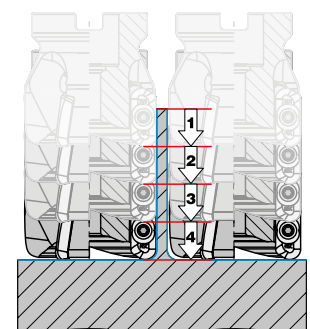

System MaxiMill HPC-04/12

Machining strategy

What do you have to take into account?

- ▲ Machine stability.
- ▲ Stable work piece clamping and tool adapter.
- ▲ Use of coolant generally not necessary, however, this will facilitate the removal of the chips - also improved surface quality.
- ▲ Take into account thermal stress and critical temperature of 600°C!
If required for material, work with coolant.
- ▲ Avoid vibration.
- ▲ Observe balancing quality class.
- ▲ Observe chemical reactions of diamond to carbide forming elements (Fe, Ti, Ta, Co, Ni)

Quality class check

After assembly, clamping of the inserts and adjustment of the axial run-out the balancing quality class of the tools should be checked. When applying shell milling cutters, after assembly with an adapter balancing is necessary.

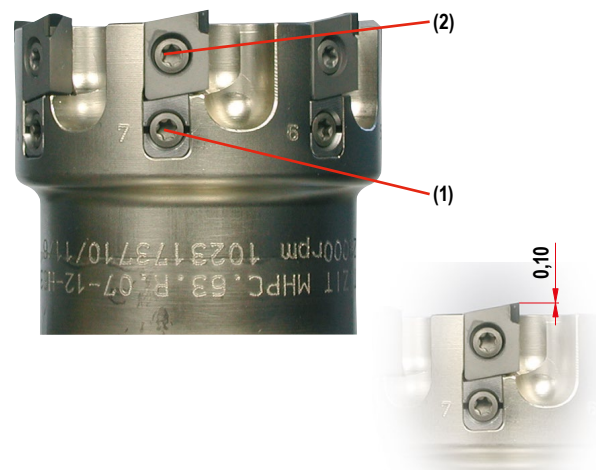

Excellent suitability

- ▲ for components made of light metals and non-ferrous metals, plastic, fibre composite materials, graphite ...
- ▲ when the simplest setting method saves cost for tool presetting.
- ▲ for high-volume production.
- ▲ for high surface quality of the work pieces.
- ▲ when long tool life is necessary to reduce tool changes and expensive machine downtime.
- ▲ when the tool is already on site (presetting, etc.)

Setting trailing edge inserts

As in the setting procedure described above the standard inserts are adjusted to a radial run-out of = 0.02 mm. The inserts with Masterfinish edge are then set to 0.02–0.03 mm above the highest cutting edge.

The adjustment procedure

- 1 Mount Adjustment wedges in the tools (as delivered). Tighten adjustment screw (1) without deforming the wedges.
 - 2 Mount the PCD inserts and tighten the clamping screws (2) with 1.0 Nm.
 - 3 Mark " highest edge" with the help of pre-setting equipment.
 - 4 Adjust the PCD insert by 0.02 mm turning the clamping screw (1) clockwise.
- Pre-loading must be reached. Use the angled TORX screwdrivers
- 5 Set other cutting edges to this level, maximum deviation of 0.005 mm. Maximum length adjustment = 0.10 mm.
 - 6 Tighten all insert tightening screws (2) to 5,0 Nm.
 - 7 Check axial run-out of all inserts: Target = 0.005 mm.

Perfect precision – MaxiMill HPC-12

The adjustable high-performance tool for the finishing of aluminium components

Tool body made of steel

- ▲ For highest stability
- ▲ Maximum abrasion resistance
- ▲ Bimetallic version from diameter 160 mm easier handling and spindle protection with large tools

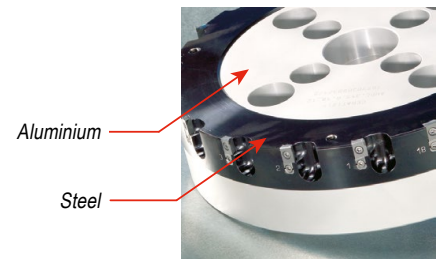

Picture shows bimetallic version

Available as shell milling cutters and monobloc type

- ▲ Direct HSK63 connection as monobloc type
- ▲ Monobloc tools balanced to G2.5 at $n=20,000 \text{ min}^{-1}$ (ISO1940)

Particularly for HSC applications with internal coolant supply

- ▲ Improved chip evacuation
- ▲ High surface quality
- ▲ Optimum application conditions
- ▲ Suitability for minimum quantity lubrication

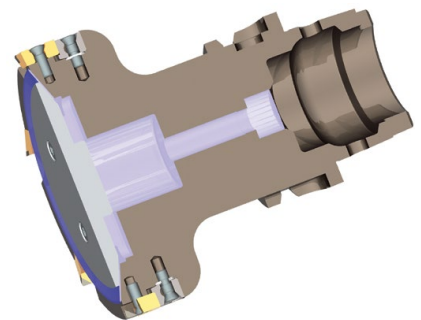

Time is money – the system MaxiMill HPC-12 is simple and quick to adjust!

Highly positive rake angle of +25°

- ▲ Low cutting forces
- ▲ Increased parallelism of surfaces
- ▲ Minimised component deformation

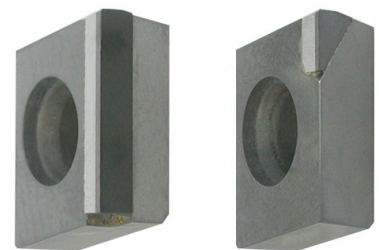

Tangential concept

- ▲ Stable location for the PCD segment and maximum process security

Adapted PCD cutting edge

- ▲ High impact strength when milling!
- ▲ Maximum edge stability
- ▲ Reduced built-up edge on the work piece
- ▲ The machining of Al-Si alloys with over 12 % silicon is possible without problems

Inserts Selection

- ▲ Standard insert
- ▲ Insert with corner radius
- ▲ Insert with trailing edge

Average chip thickness [h_m] – the approach

Shoulder milling

1 Select appropriate average chip thickness [h_m] for the steel from the table.

Material	Tensile strength	h _m mm
	N/mm ²	
for steel	...-800	0,16
for steel	800-1000	0,14
for steel	1000-1200	0,12
for steel	1200-...	0,10
for stainless steel	...-750	0,15
for stainless steel	750-900	0,13
for stainless steel	900-1150	0,11
for stainless steel	1150-...	0,09 *

2 Select the corrected feed rate value from the table based on the appropriate chip thickness [h_m] and depth of cut [a_e].

h _m mm	Corrected feed value f _z for h _m				
	0,2 x DC	0,3 x DC	0,4 x DC	0,75 x DC	1 x DC
0,16	0,36	0,29	0,25	0,18	0,16
0,14	0,31	0,26	0,22	0,16	0,14
0,12	0,27	0,22	0,19	0,14	0,12
0,10	0,22	0,18	0,16	0,12	0,10
0,15	0,34	0,27	0,24	0,17	0,15
0,13	0,29	0,24	0,21	0,15	0,13
0,11	0,25	0,20	0,17	0,13	0,11
0,09 *	0,20	0,16	0,14	0,10	0,09 *
a _e =	0,2 x DC	0,3 x DC	0,4 x DC	0,75 x DC	1 x DC

* f_z < 0,08 mm: Danger, as tool is not working and cutting

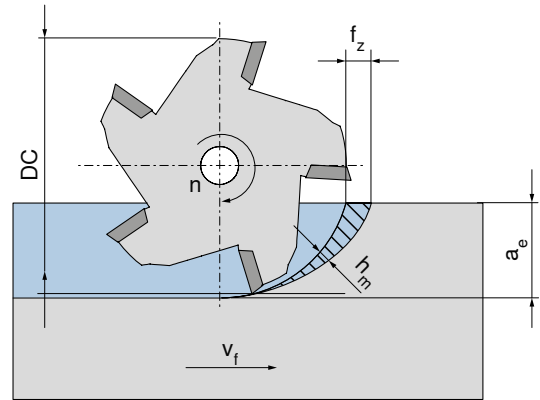

Start values f_z in mm from starting parameter diagram

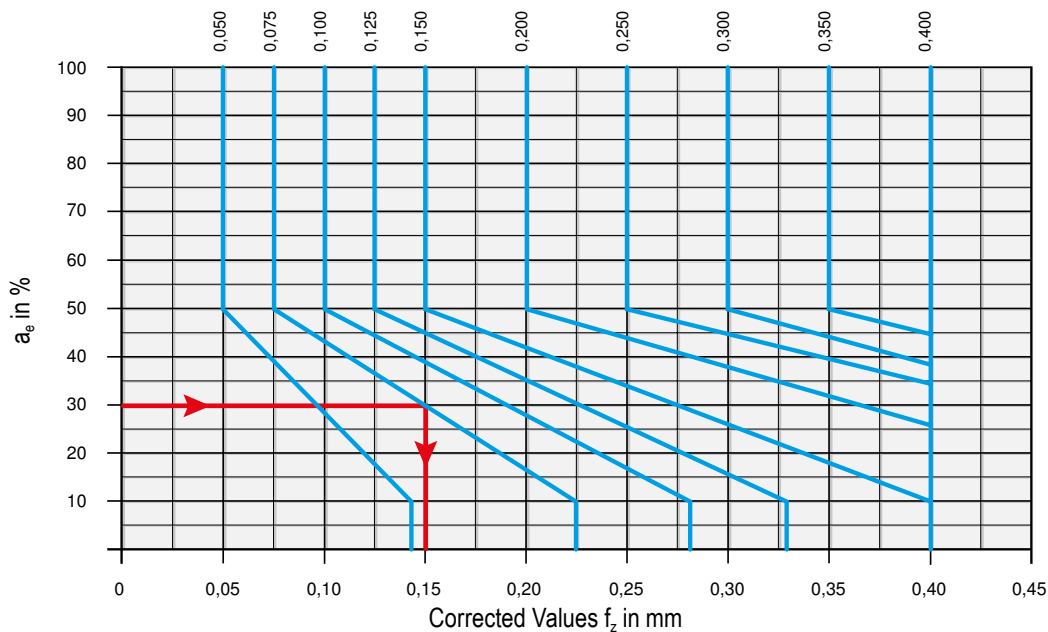

➔ **Example:**
Start value (f_z) = 0.075 mm
a_e = 30 %
corrected value (f_z) = 0.15 mm

System MaxiMill HFC-06

Machining strategy

Programmed radius R = 1.2 mm

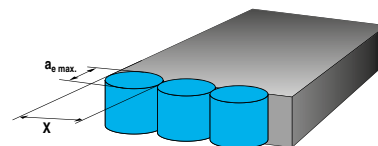
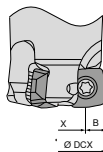
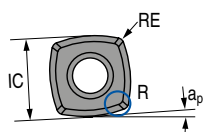

Cutting depth and remaining material			Cutting width for flat surfaces			Cutting depth when plunging				
IC in mm	RE in mm	ap,max. in mm	DCX in mm	X in mm	B in mm	ae,max. in mm	fz in mm		X	
							initial	min.	max.	
6,35	0,5	0,8	16-32	DCX-(2 x B)	4,3	5,3	0,10	0,08	0,15	<0,7 x DCX



DCX mm	Helical plunging (helical plunging into solid material)		
	Dmin. mm	Dmax. mm	α R max. °
16	22	31	4,5°
20	30	39	2,3°
25	40	49	1,3°
32	54	63	0,9°
42	74	83	0,6°



DCX mm	axial	Angled
	Plunging	
	Xmax. mm	α R max. °
16		5,9°
20		3,2°
25	0,5	2°
32		1,3°
42		0,7°

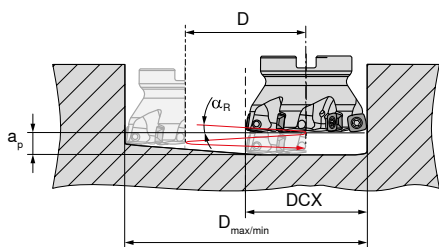

Starting Parameter



XPLX 06

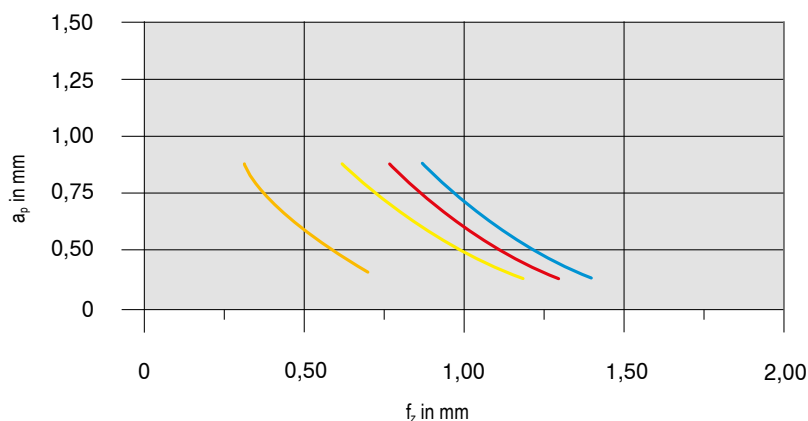

Material		Inserts		vc in m/min	Cooling
Steel	P.2.2 40CrMnMoS 8-6	XPLX 060305SR-M50	CTPP235	200	Dry
Stainless steel	M.1.1 X6CrNiMoTi 1712 2	XPLX 060305ER-M50	CTPM240	180	Dry
Cast iron	K.1.1 EN-GJL-250 (GG25)	XPLX 060305ER-M50	CTCK215	250	Dry
Heat-resistant	S.2.2 Inconel 718	XPLX 060305SR-F40	CTC5240	35	Emulsion

Detailed information on cutting speed for each grade can be found on → page 146-148

From vc > 400 m/min, the tool must be balanced!

System MaxiMill HFC-09

Machining strategy

Programmed radius R = 2 mm

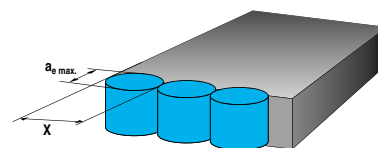
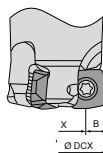
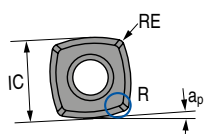

Cutting depth and remaining material			Cutting width for flat surfaces			Cutting depth when plunging				
IC in mm	RE in mm	ap max. in mm	DCX in mm	X in mm	B in mm	ae max. in mm	fz in mm		X	
							initial	min.	max.	
9	0,8	1	25–66	DCX–(2 x B)	5,9	7,5	0,10	0,08	0,15	<0,7 x DCX



DCX mm	circular Helical plunging (helical plunging into solid material)		
	Dmin. mm	Dmax. mm	α R max. °
25	35	48	3,1°
32	49	62	1,7°
35	55	68	1,4°
40	65	78	1,0°
42	69	82	0,9°
50	85	98	0,8°
52	89	102	0,7°
63	111	124	0,7°
66	117	130	0,6°

DCX mm	axial	Angled
	Plunging	
	Xmax. mm	α R max. °
25		3,6°
32		2,0°
35		1,6°
40		1,2°
42	0,75	1,1°
50		0,9°
52		0,8°
63		0,8°
66		0,7°

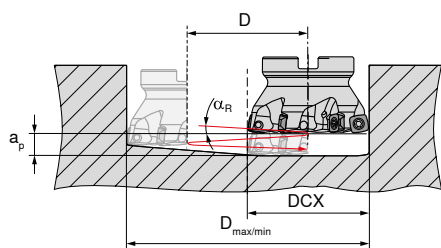

Starting Parameter



XDLX 09

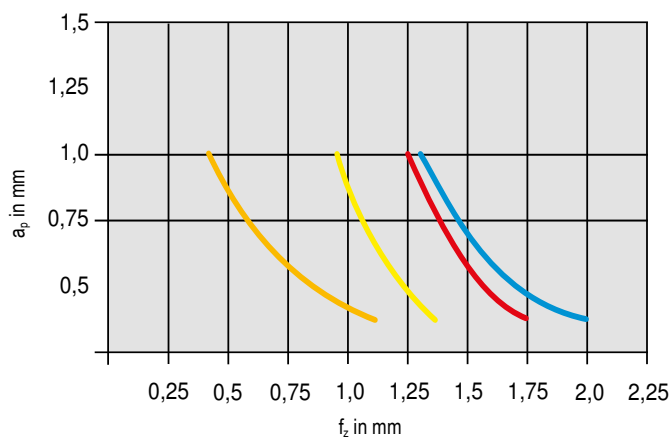

Material	P.2.2	40CrMnMoS 8-6	Inserts	vc in m/min	Cooling
Steel	P.2.2	40CrMnMoS 8-6	XDLX09T308SR-M50 CTPP235	200	Dry
Stainless steel	M.1.1	X6CrNiMoTi 1712 2	XDLX09T308SR-M50 CTPM240	180	Dry
Cast iron	K.1.1	EN-GJL-250 (GG25)	XDLX09T308SR-M50 CTCK215	250	Dry
Heat-resistant	S.2.2	Inconel 718	XDLX09T308ER-F40 CTC5240	35	Emulsion

Detailed information on cutting speed for each grade can be found on → page 146–148

From $v_c > 400$ m/min, the tool must be balanced!

System MaxiMill HFC-12

Machining strategy

Programmed radius R = 3 mm

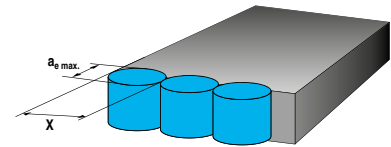
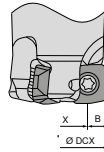
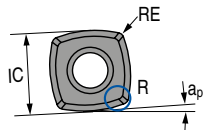

Cutting depth and remaining material			Cutting width for flat surfaces			Cutting depth when plunging				
IC in mm	RE in mm	$a_{p \max}$ in mm	DCX in mm	X in mm	B in mm	$a_e \max$ in mm	f_z in mm		X	
							initial	min.	max.	
12	1,0	2	32-100	DCX-(2 x B)	8,3	10	0,15	0,10	0,20	<0,7 x DCX



DCX mm	circular Helical plunging (helical plunging into solid material)		
	D_{\min} mm	D_{\max} mm	$\alpha_{R \max}$ °
32	44	62	6,1°
35	50	68	3,7°
40	60	78	2,5°
42	64	82	2,3°
50	80	98	1,3°
52	84	102	1,3°
63	106	124	0,9°
66	112	130	0,9°
80	140	158	1,1°
100	180	198	0,6°

DCX mm	axial	Angled
	X_{\max} mm	$\alpha_{R \max}$ °
32	1,15	7,2°
35		4,4°
40		2,9°
42		2,7°
50 + 52		1,5°
63 + 66		1,1°
80		1,3°
100		0,7°

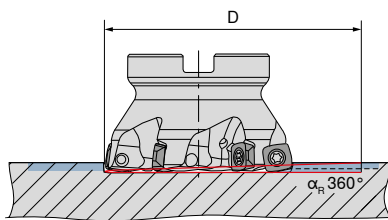

Starting Parameter



XOLX 12

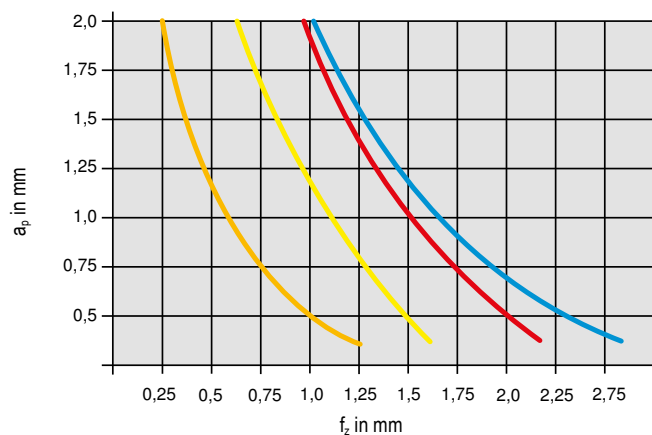

Material	P.2.2	40CrMnMoS 8-6	Inserts	v_c in m/min	Cooling
Steel	P.2.2	40CrMnMoS 8-6	XOLX120410SR-M50 CTPP235	200	Dry
Stainless steel	M.1.1	X6CrNiMoTi 1712 2	XOLX120410ER-M50 CTPM240	180	Dry
Cast iron	K.1.1	EN-GJL-250 (GG25)	XOLX120410ER-M50 CTC215	250	Dry
Heat-resistant	S.2.2	Inconel 718	XOLX120410ER-F40 CTC5240	35	Emulsion

Detailed information on cutting speed for each grade can be found on → page 146-148
From $v_c > 400$ m/min, the tool must be balanced!

System MaxiMill HFC-19

Machining strategy

Programmed radius R = 5 mm

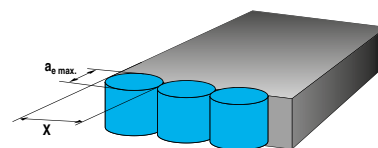
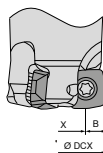
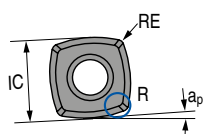

Cutting depth and remaining material			Cutting width for flat surfaces			Cutting depth when plunging				
IC in mm	RE in mm	ap max. in mm	DCX in mm	X in mm	B in mm	ae max. in mm	fz in mm		X	
							initial	min.	max.	
19,14	1,5	3,3	63-160	DCX-(2 x B)	13,1	12	0,2	0,10	0,25	<0,65 x DCX



DCX mm	circular Helical plunging (helical plunging into solid material)		
	Dmin. mm	Dmax. mm	α R max. °
63	97	123	2,5°
80	131	157	1,4°
100	171	197	1,0°
125	221	247	0,7°
160	291	317	0,5°



DCX mm	axial		Angled	
	Xmax. mm	α R max. °	Plunging	
			ap max. mm	
63		2,9°		
80		1,8°		
100	1,7	1,3°	3,3	
125		1,0°		
160		0,7°		

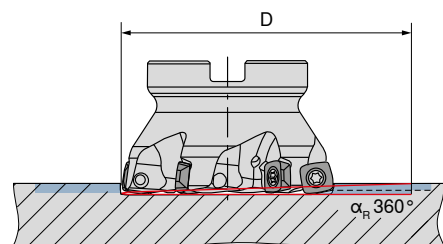

Starting Parameter



XOLX 19

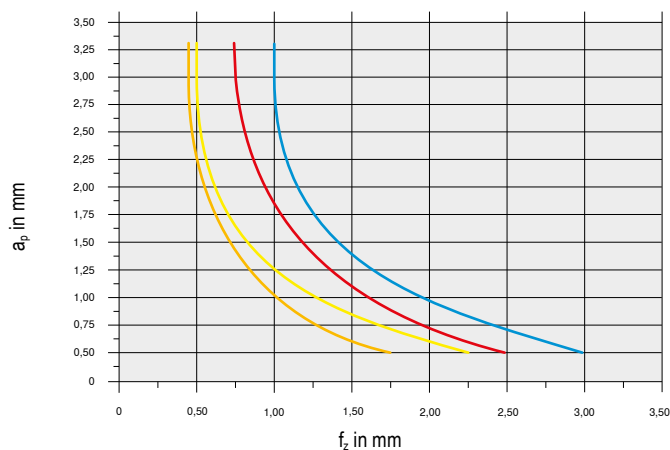

Material	P.2.2	40CrMnMoS 8-6	Inserts	CTPP235	vc in m/min	Cooling
Steel	P.2.2	40CrMnMoS 8-6	XOLX190615SR-M50	CTPP235	200	Dry
Stainless steel	M.1.1	X6CrNiMoTi 1712 2	XOLX190615SR-M50	CTPM240	180	Dry
Cast iron	K.1.1	EN-GJL-250 (GG25)	XOLX190615SR-M50	CTCK215	250	Dry
Heat-resistant	S.2.2	Inconel 718	XOLX190615ER-F40	CTC5240	35	Emulsion

Detailed information on cutting speed for each grade can be found on → page 146-148
From vc > 400 m/min, the tool must be balanced!

System MaxiMill DHFC

Cutting data standard values

for standard inserts

Material	F			M			R		
	v_c m/min	f_z mm	a_p mm	v_c m/min	f_z mm	a_p mm	v_c m/min	f_z mm	a_p mm
Steel	130–300	0,25–1,0	0,7	130–300	0,25–1,0	0,75			
Stainless steel				90–210	0,25–1,0	0,60			
Cast iron				120–270	0,2–1,1	0,70	120–270	0,2–1,2	0,75
Non-ferrous metals									
Heat-resistant				40–80	0,15–0,75	0,6			
Tempered steel									
Non-metal materials									

Machining strategy

Programmed Radius R = 1,4 mm

Helical plunging

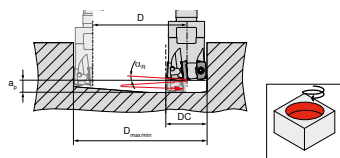

DC mm	D_{min} mm	D_{max} mm	α°
16	23	31	2,5
20	31	39	1,9
25	41	49	1,5
32	55	63	1,2
35	61	69	1,0
42	75	83	0,9

Axial plunging into solid material



DC mm	X_{max} mm
16	0,35
20	0,40
25	0,45
32–35	0,50
40	0,55

Angled ramping



DC mm	α°	y mm
16	<2,5	7
20	<1,9	11
25	<1,5	16
32	<1,2	23
35	<1,0	26
42	<0,9	33

 Detailed information on cutting speed for each grade can be found on → page 146–148

MaxiMill 251/251 RS system

Technical data

Recommended cutting depth

Ø mm	4-position			8-face
	a _{p max.} mm	a _{p max.} theoretical mm		a _{p max.} mm
5	1,0	2,0		0,7
8	1,5	3,5		1,1
10	2,5	4,5		1,4
12	3,0	5,5		1,7
16	4,0	7,5		2,3
20	4,0	9,5		2,9

Average depth for the 4/8 index use of the insert

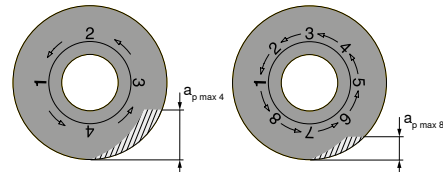

Detailed information on cutting speed for each grade can be found on → page 146–148

Angled ramping

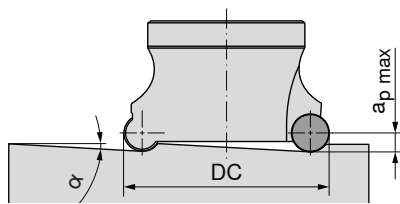

Ø DC mm	05 α °	08 α °	10 α °	12 α °	16 α °	20 α °
10	3,4					
12	16,0					
16	8,0	5,0				
20	5,5	20,0	1,3			
25	4,0	13,0	2,0	6,0		
32	3,0	8,0	3,0	4,0		
40			3,3	2,8		
42			3,1			
50			2,4	2,6	4,0	
52			2,2	2,3		
63				1,9	2,8	
66				1,6		
80				1,3	2,0	3,2
100				1,0	1,5	2,3
125						1,7

Axial ramping

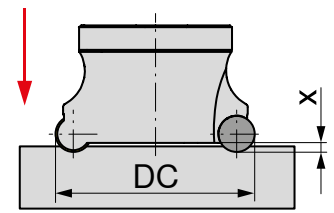

Ø DC mm	05 X _{max.} mm	08 X _{max.} mm	10 X _{max.} mm	12 X _{max.} mm	16 X _{max.} mm	20 X _{max.} mm
10	0,5					
12	1,3					
16	1,3	0,5				
20	1,3	2,7	0,2			
25	1,3	2,7	0,4	1,0		
32	1,3	2,7	0,8	1,1		
40			1,5	1,2		
42			1,5	1,5		
50			1,5	1,5	2,0	
52			1,5	1,5	2,0	
63				1,5	2,0	
66				1,5	2,0	
80				1,5	2,0	3,0
100				1,5	2,0	3,0
125						3,0

Helical plunging

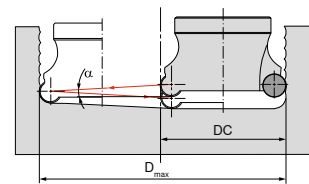
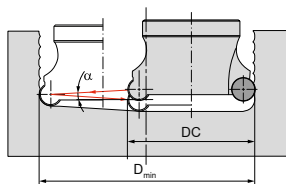

D_{min.} = smallest drilling diameter depending on the tool diameter

D_{max.} = Maximum hole diameter Depending on the tool diameter

maximum possible hole diameter = 2 x DC – 1 mm

Ø DC mm	05			08			10			12			16			20			
	D _{min.} mm	D _{max.} mm	α _R °	D _{min.} mm	D _{max.} mm	α _R °	D _{min.} mm	D _{max.} mm	α _R °	D _{min.} mm	D _{max.} mm	α _R °	D _{min.} mm	D _{max.} mm	α _R °	D _{min.} mm	D _{max.} mm	α _R °	
10	12	15	2,5																
12	16	19	2,1																
16	24	27	1,5	21	24	2,4													
20	32	35	1,2	27	32	1,9	26	30	1,3										
25	42	45	1,0	37	42	1,5	37	40	1,8	31	38	2,2							
32	56	59	0,7	51	56	1,2	50	54	1,5	46	52	1,7							
40							64	70	1,1	62	68	1,4							
42							68	74	1,1										
50							84	90	0,9	81	88	1,1	75	84	1,5				
52							88	94	0,9	86	92	1,0							
63										107	114	0,9	101	110	1,1				
66										113	120	0,8							
80										142	148	0,7	135	144	0,9	128	140	1,1	
100										181	188	0,5	175	184	0,7	168	180	0,9	
125																218	230	0,7	

R100. system





Cutting data standard values





Index	WTN1205	WTN1205	WAN2225	WAN2225	WAN1240	WAN1240	WAX1240	WAX1240	WUN4210	WUN4210
	v _c (m/min)									
P.1.1	275	150			300	180	200	100		
P.1.2	230	130			270	160	170	90		
P.1.3	190	100			225	130	140	80		
P.1.4	230	130			270	160	170	90		
P.1.5	210	110			240	140	160	90		
P.2.1	230	130			270	160	170	90		
P.2.2	170	100			200	120	130	70		
P.2.3	230	130			270	160	170	90		
P.2.4	160	90			180	110	120	60		
P.3.1	230	130			270	160	170	90		
P.3.2	150	110			180	140	140	80		
P.3.3	130	90			150	120	120	70		
P.4.1	150	110			180	140	140	80		
P.4.2	150	100			170	130	130	70		
M.1.1	230	130	230	140	270	160	170	90		
M.2.1			200	120						
M.3.1										
K.1.1	275	200			360	90	150	110	200	150
K.1.2	150	100			360	90	150	110	150	120
K.2.1	180	100			230	170	150	110	200	150
K.2.2	150	100			160	110	150	110	160	130
K.3.1	180	100			210	160			200	150
K.3.2	180	100			210	160			150	120
N.1.1										1200
N.1.2										800
N.2.1										880
N.2.2										800
N.2.3										230
N.3.1										280
N.3.2										280
N.3.3										160
N.4.1										260
S.1.1				50						
S.1.2				45						
S.2.1				24						
S.2.2				16						
S.2.3				20						
S.3.1				50						
S.3.2				32						
S.3.3				25						
H.1.1	140	80								
H.1.2	120	70								
H.1.3	80	40								
H.1.4										
H.2.1										
H.3.1										
O.1.1									180	150
O.1.2										
O.2.1									260	230
O.2.2										
O.3.1									450	





The cutting data is strongly influenced by external conditions, such as the stability of the tool and workpiece clamping, material and type of machine. The specified values represent guideline cutting data that can be adjusted by approx. ±20% according to the usage conditions.

System R 1000, 1002, 1007

Cutting data standard values





		f_z / a_p mm	WTN1205	WAN2225	WAN1240	WAX1240	WUN4210
Steel							
	0702	f_z	0,1–0,7			0,2–0,5	0,1–0,2
		a_p	0,1–0,7			0,1–0,75	0,1–0,2
	1003	f_z	0,1–0,3		0,2–0,9	0,2–0,7	0,15–0,3
		a_p	0,1–1,0		0,2–1,5	0,2–1,5	0,1–0,3
	12T3	f_z	0,1–0,3		0,25–1,0	0,–0,8	0,15–0,3
		a_p	0,1–1,5		0,2–2,0	0,2–2,0	0,1–0,3
	1604	f_z	0,2–0,3		0,3–1,2	0,25–1,0	0,15–0,3
		a_p	0,2–1,5		0,25–3,0	0,2–3,0	0,1–0,4



Stainless steel							
	0702	f_z	0,1–0,2			0,2–0,5	0,1–0,2
		a_p	0,1–0,2			0,1–0,75	0,1–0,2
	1003	f_z	0,15–0,3	0,15–0,6		0,2–0,7	0,15–0,3
		a_p	0,1–0,3	0,4–1,0		0,2–1,5	0,1–0,3
	12T3	f_z	0,15–0,3	0,2–0,8		0,–0,8	0,15–0,3
		a_p	0,1–0,3	0,5–2,0		0,2–2,0	0,1–0,3
	1604	f_z	0,15–0,3	0,3–1,0		0,25–1,0	0,15–0,3
		a_p	0,1–0,3	0,6–3,0		0,2–3,0	0,1–0,3





Cast iron							
	0702	f_z	0,1–0,3			0,1–0,3	0,1–0,3
		a_p	0,1–0,7			0,1–0,7	0,1–0,7
	1003	f_z	0,15–0,3		0,1–0,3	0,1–0,3	0,15–0,3
		a_p	0,1–1,0		0,1–1,0	0,1–1,0	0,1–1,0
	12T3	f_z	0,15–0,4		0,1–0,4	0,1–0,4	0,15–0,4
		a_p	0,1–1,5		0,1–1,15	0,1–1,5	0,1–1,5
	1604	f_z	0,2–0,5		0,2–0,05	0,2–0,5	0,2–0,5
		a_p	0,2–3,0		0,2–2,0	0,2–3,0	0,2–3,0

System R 1000, 1002, 1007

Cutting data standard values





		f_z / a_p mm	WTN1205	WAN2225	WAN1240	WAX1240	WUN4210
Non-ferrous metals							
	0702	f_z					0,1–0,3
		a_p					0,1–1,0
	1003	f_z					0,1–0,3
		a_p					0,1–1,5
	12T3	f_z					0,1–0,4
		a_p					0,1–2,0
	1604	f_z					0,2–0,5
		a_p					0,2–4,0

Heat-resistant							
	1003	f_z		0,1–0,4			
		a_p		0,2–1,0			
	12T3	f_z		0,15–0,5			
		a_p		0,3–1,5			
	1604	f_z		0,15–0,5			
		a_p		0,3–2,0			

Tempered steel							
	0702	f_z	0,1–0,2				
		a_p	0,1–0,3				
	1003	f_z	0,1–0,2				
		a_p	0,1–0,5				
	12T3	f_z	0,1–0,25				
		a_p	0,1–0,7				
	1604	f_z	0,15–0,3				
		a_p	0,2–1,0				

WTN 1205

Up to 48 HRC: a_p -range as indicated in the table
Up to 55 HRC: maximum value $a_p \times 0,7$
Up to 65 HRC: maximum value $a_p \times 0,5$

Non-metal materials							
	0702	f_z					0,1–0,3
		a_p					0,1–1,0
	1003	f_z					0,1–0,3
		a_p					0,1–1,5
	12T3	f_z					0,1–0,4
		a_p					0,1–2,0
	1604	f_z					0,2–0,5
		a_p					0,2–4,0

System R 1000, 1002, 1007

Machining strategy

Axial ramping

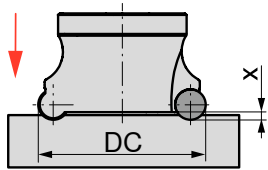

reduce f_z to 30% according to application table
→ v_c Page 182–184

	07	10	12	16
ØDC mm	X _{max} mm	X _{max} mm	X _{max} mm	X _{max} mm
8–160	1,2	2,5	3,0	4,0

Angled ramping

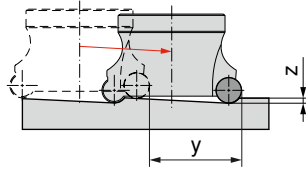
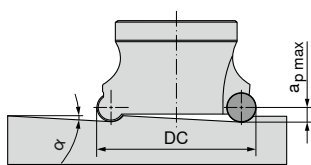

y = minimum cutter movement
z = minimum cutter movement
a_p / f_z application table

→ v_c Page 182–184

ØDC mm	07			10			12			16		
	α°	y mm	z mm	α°	y mm	z mm	α°	y mm	z mm	α°	y mm	z mm
8												
10												
12												
14												
15	26,5	2	< 1,2									
16	14,0	4	< 1,2									
18	11,3	6	< 1,2									
20	8,5	8	< 1,2									
22												
24												
25	5,3	13	< 1,2	19,7	7	< 2,5						
30	3,8	18	< 1,2	11,7	12	< 2,5						
32												
35	3,0	23	< 1,2	8,4	17	< 2,5	13,0	13	< 3,0	38,7	5	< 4,0
40												
42	2,3	30	< 1,2	5,9	24	< 2,5	8,5	20	< 3,0			
50												
52				4,2	34	< 2,5	5,7	30	< 3,0	10,3	22	< 4,0
66							3,9	44	< 3,0	6,4	36	< 4,0
80							3,0	58	< 3,0	4,6	50	< 4,0
100										3,3	70	< 4,0
125										2,4	95	< 4,0
160										1,8	130	< 4,0

System R 1000, 1002, 1007

Machining strategy

Helical plunging

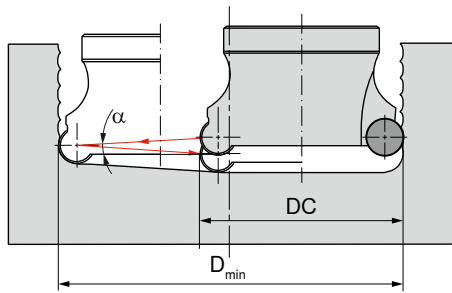

D_{min} = smallest drilling diameter depending on the tool diameter

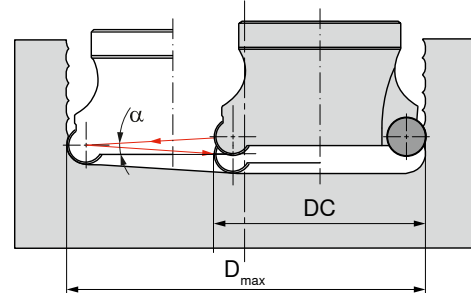

D_{max} = largest drilling diameter depending on the tool diameter

i a_p / f_z according to table
→ v_c Page 182-184

07				10			12			16		
$\emptyset DC$ mm	α°	y mm	z mm	α°	y mm	z mm	α°	y mm	z mm	α°	y mm	z mm
8												
10												
12	24											
14	28											
15	30											
16	32											
18	36	20	36									
20	40	22	40									
22				24	44							
24				26	48							
25	50	32	50									
30	60	42	60									
32						34	64					
35	80	72	70	48	70	40	70			38,7	5	< 4,0
40								42	80			
42	84	66	84	62	84							
50								62	100			
52		86	104	82	104	74	104			10,3	22	< 4,0
66				110	132	102	132	94	132	6,4	36	< 4,0
80				138	160	130	160	122	160	4,6	50	< 4,0
100						170	200	162	200	3,3	70	< 4,0
125						220	250	212	250	2,4	95	< 4,0
160						290	320	282	320	1,8	130	< 4,0

System MaxiMill 252

Machining strategy

Recommended cutting depth

Ø mm	4-position	
	$a_{p\ max}$ mm	mm
10	2,5	4,5
12	3,0	5,5

Starting Parameter



RNHU 10

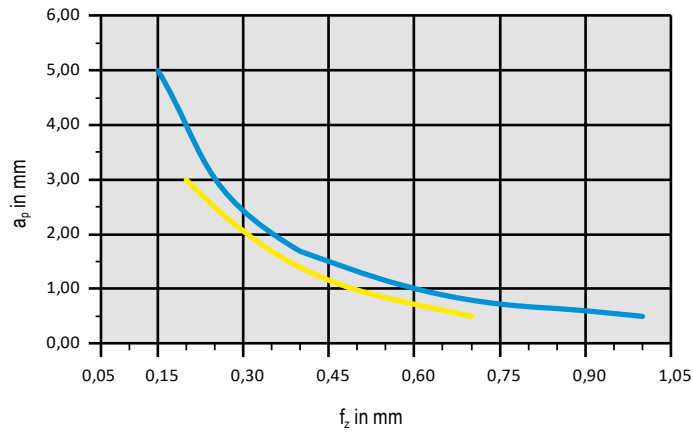

Material	P.2.2	40CrMnMoS 8-6	Inserts		v_c in m/min	Cooling
Steel	P.2.2	40CrMnMoS 8-6	XOLX120410SR-M50	CTPP235	180	Dry
Stainless steel	M.1.1	X6CrNiMoTi 1712 2	XOLX120410ER-M50	CTPM240	180	Dry

Starting Parameter



RNHU 12

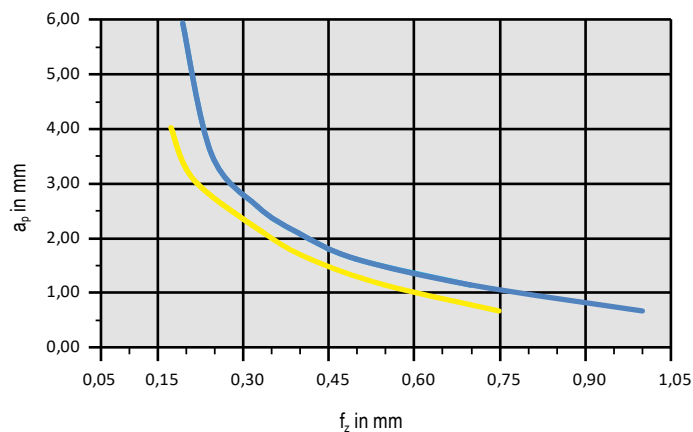

Material	P.2.2	40CrMnMoS 8-6	Inserts		v_c in m/min	Cooling
Steel	P.2.2	40CrMnMoS 8-6	XOLX120410SR-M50	CTPP235	180	Dry
Stainless steel	M.1.1	X6CrNiMoTi 1712 2	XOLX120410ER-M50	CTPM240	180	Dry



Detailed information on cutting speed for each grade can be found on → page 146–148

From $v_c > 400$ m/min, the tool must be balanced!

Cutting data standard values for copy milling cutter K200.

Index	CTPK226		CTPP211		CTPK231		CTCN211		CTPP216		● 1st choice ○ suitable			
	R	F	R	F	R	F	R	F	R	F	Emulsion	Compressed air	MMS	
	v _c (m/min)													
P.1.1		280-300	180-220	220-280	160-200					220-300	280-300	○	●	●
P.1.2		220-240	180-220	220-280	160-200					220-300	280-300	○	●	●
P.1.3		220-240	180-220	220-280	160-200					220-300	280-300	○	●	
P.1.4		220-240	180-220	220-280	160-200					220-300	280-300	○	●	
P.1.5		220-240	180-220	220-280	160-200					220-300	280-300	○	●	
P.2.1		280-300	180-220	220-280	160-200					220-300	280-300	○	●	●
P.2.2		280-300	180-220	220-300	160-200					220-300	280-300	○	●	●
P.2.3		280-300	180-220	240-320	160-200					250-360	240-320	○	●	
P.2.4		280-300	180-220	240-320	160-200					250-360	240-320	○	●	
P.3.1		280-300	180-220	220-280	160-200					220-300	280-300	○	●	
P.3.2		280-320	180-220	240-320	160-200					250-360	240-320	○	●	●
P.3.3		280-320	180-220	240-320	160-200					250-360	240-320	○	●	●
P.4.1		220-220	140-180	200-240	120-180					140-180	200-240	○	●	
P.4.2		220-220	140-180	200-240	120-180					140-180	200-240	○	●	
M.1.1		180-200	140-160	180-200	120-160					220-250	220-240	●	○	
M.2.1		180-200	140-160	180-240	120-160					220-250	220-240	●		
M.3.1		220-220	140-180	200-240	120-180					140-180	200-240	●		
K.1.1		280-300	160-200	200-300	120-200					240-350	240-260		●	○
K.1.2		280-300	160-200	200-300	120-200					240-350	240-260		●	○
K.2.1		280-300	160-200	200-300	120-200					240-350	240-260		●	○
K.2.2		300-350	180-220	240-350	180-200					340-400	240-360		●	○
K.3.1		300-350	180-220	240-350	180-200					340-400	240-360		●	○
K.3.2		240-260	160-200	220-260	160-200					280-340	220-300		●	○
N.1.1			240-280	300-600	300-600						400-450	●		
N.1.2			240-280	300-600	300-600						400-450	●		
N.2.1			240-280	300-600	300-600						400-450	●		
N.2.2			240-280	300-600	300-600						400-450	●		
N.2.3											300-400	●		
N.3.1			240-280	280-320	240-280						300-400	●		
N.3.2			240-280	280-320	240-280						300-400	●		
N.3.3			240-280	280-320	240-280						300-400	●		
N.4.1			300-400	300-400				300-400				●		
S.1.1				80-120	80-120						60-80	●		
S.1.2				80-120	80-120						60-80	●		
S.2.1				80-120	80-120						60-80	●		
S.2.2				80-120	80-120						60-80	●		
S.2.3				80-120	80-120						60-80	●		
S.3.1				60-80	80-120						60-80	●		
S.3.2				60-80	60-80						60-80	●	○	
S.3.3				60-80	60-80						60-80	●	○	
H.1.1		240-260		280-300	140-160					240-260	240-260		●	
H.1.2		240-260		280-300	80-100					220-240	160-240		●	○
H.1.3		200-220		240-260						120-140	100-140		●	○
H.1.4		120-140		160-200									●	○
H.2.1		240-260		280-300	80-100					220-240	160-240		●	○
H.3.1		240-260		280-300	80-100					220-240	160-240		●	
O.1.1			300-400	300-400							300-350		●	
O.1.2			500-600	500-600							600-800		●	
O.2.1			300-400	300-400									●	
O.2.2			300-400	300-400									●	
O.3.1							400-600	600-800					●	

Cutting data standard values for copy milling cutter K200.

Index	Roughing (R)		Finishing (F)		only for -MR3 Roughing (R)		● 1st choice ○ suitable		
	Ø 6-16	Ø 20-32	Ø 6-16	Ø 20-32	Ø 6-16	Ø 20-32	Emulsion	Compressed air	MMS
	f _z (mm/tooth)								
P.1.1	0,08-0,4	0,25-0,5	0,08-0,3	0,2-0,8	0,3-0,8	1,2-1,5	○	●	●
P.1.2	0,08-0,4	0,25-0,5	0,08-0,3	0,2-0,8	0,3-0,8	1,2-1,5	○	●	●
P.1.3	0,08-0,4	0,25-0,5	0,08-0,3	0,2-0,8	0,3-0,8	1,2-1,5	○		●
P.1.4	0,08-0,4	0,25-0,5	0,08-0,3	0,2-0,8	0,3-0,6	0,8-1,25	○		●
P.1.5	0,08-0,4	0,25-0,5	0,08-0,3	0,2-0,8	0,3-0,6	0,8-1,25	○		●
P.2.1	0,08-0,4	0,25-0,5	0,08-0,3	0,2-0,8	0,3-0,8	1,2-1,5	○	●	●
P.2.2	0,08-0,4	0,25-0,5	0,08-0,3	0,2-0,8	0,3-0,6	0,8-1,25	○	●	●
P.2.3	0,08-0,4	0,25-0,5	0,08-0,3	0,2-0,8	0,3-0,6	0,8-1,25	○		●
P.2.4	0,08-0,4	0,25-0,5	0,08-0,3	0,2-0,8	0,3-0,6	0,8-1,25	○		●
P.3.1	0,08-0,4	0,25-0,5	0,08-0,3	0,2-0,8	0,3-0,8	1,2-1,5	○		●
P.3.2	0,08-0,4	0,25-0,5	0,08-0,3	0,2-0,8	0,3-0,6	0,8-1,25	○	●	●
P.3.3	0,08-0,4	0,25-0,5	0,08-0,3	0,2-0,8	0,3-0,6	0,8-1,25	○	●	●
P.4.1	0,08-0,4	0,25-0,5	0,08-0,3	0,2-0,8	0,3-0,8	1,2-1,5	○		●
P.4.2	0,08-0,4	0,25-0,5	0,08-0,3	0,2-0,8	0,3-0,8	1,2-1,5	○		●
M.1.1	0,08-0,4	0,25-0,5	0,08-0,3	0,2-0,5	0,3-0,6	0,8-1,5	●	○	
M.2.1	0,08-0,4	0,25-0,5	0,08-0,4	0,2-0,6	0,3-0,6	0,8-1,25	●		
M.3.1	0,08-0,4	0,25-0,5	0,08-0,5	0,2-0,7	0,3-0,6	0,8-1,25	●		
K.1.1	0,08-0,4	0,25-0,5	0,08-0,3	0,2-0,5	0,3-0,8	1,0-1,5		●	○
K.1.2	0,08-0,5	0,25-0,6	0,08-0,4	0,2-0,6	0,3-0,8	1,0-1,5		●	○
K.2.1	0,08-0,6	0,25-0,7	0,08-0,5	0,2-0,7	0,3-0,8	1,0-1,5		●	○
K.2.2	0,08-0,7	0,25-0,8	0,08-0,6	0,2-0,8	0,3-0,6	0,8-1,25		●	○
K.3.1	0,08-0,8	0,25-0,9	0,08-0,7	0,2-0,9	0,3-0,6	0,8-1,25		●	○
K.3.2	0,08-0,9	0,25-0,10	0,08-0,8	0,2-0,10	0,3-0,6	0,8-1,25		●	○
N.1.1	0,08-0,35	0,25-0,45	0,06-0,25	0,025-0,45			●		
N.1.2	0,08-0,36	0,25-0,46	0,06-0,26	0,025-0,46			●		
N.2.1	0,08-0,37	0,25-0,47	0,06-0,27	0,025-0,47			●		
N.2.2	0,08-0,38	0,25-0,48	0,06-0,28	0,025-0,48			●		
N.2.3	0,08-0,39	0,25-0,49	0,06-0,29	0,025-0,49			●		
N.3.1	0,08-0,40	0,25-0,50	0,06-0,30	0,025-0,50			●		
N.3.2	0,08-0,41	0,25-0,51	0,06-0,31	0,025-0,51			●		
N.3.3	0,08-0,42	0,25-0,52	0,06-0,32	0,025-0,52			●		
N.4.1	0,08-0,43	0,25-0,53	0,06-0,33	0,025-0,53			●		
S.1.1	0,08-0,3	0,15-0,4	0,05-0,2	0,15-0,25	0,25-0,5	0,6-1,0	●		
S.1.2	0,08-0,3	0,15-0,4	0,05-0,2	0,15-0,25	0,25-0,5	0,6-1,0	●		
S.2.1	0,08-0,3	0,15-0,4	0,05-0,2	0,15-0,25	0,25-0,5	0,6-1,0	●		
S.2.2	0,08-0,3	0,15-0,4	0,05-0,2	0,15-0,25	0,25-0,5	0,6-1,0	●		
S.2.3	0,08-0,3	0,15-0,4	0,05-0,2	0,15-0,25	0,25-0,5	0,6-1,0	●		
S.3.1	0,08-0,3	0,15-0,4	0,05-0,2	0,15-0,25	0,25-0,5	0,6-1,0	●		
S.3.2	0,08-0,35	0,4-0,5	0,08-0,3	0,25-0,5	0,25-0,5	0,6-1,0	●	○	
S.3.3	0,08-0,35	0,4-0,5	0,08-0,3	0,25-0,5	0,25-0,5	0,6-1,0	●	○	
H.1.1								●	
H.1.2								●	○
H.1.3								●	○
H.1.4								●	○
H.2.1								●	○
H.3.1								●	
O.1.1								●	
O.1.2								●	
O.2.1								●	
O.2.2								●	
O.3.1								●	

Maximum axial depths of cut a_p for copy milling cutter K200.



Ball nose insert									
Insert Ø in mm		6	8	10	12	16	20	25	32
		$a_{p \max.}$	$a_{p \max.}$	$a_{p \max.}$	$a_{p \max.}$	$a_{p \max.}$	$a_{p \max.}$	$a_{p \max.}$	$a_{p \max.}$
ROHX-FM3	R	0,8	1,0	1,5	2,0	3,0	4,0	5,0	6,0
	F	0,4	0,8	1,0	1,2	1,5	1,5	2,0	2,0
ROHX-FM4	R	0,8	1,0	2,0	3,0	4,0	5,0	6,0	8,0
	F	0,4	0,8	1,0	1,2	1,5	1,5	2,0	2,0
ROHX-FM6	R	0,8	1,0	1,5	2,0	3,0	4,0	5,0	6,0
	F	0,4	0,8	1,0	1,2	1,5	1,5	2,0	2,0
ROGX-MR4	R*				4,0	6,0	8,0	12,0	16,0
	F				2,0	3,0	4,0	5,0	6,0
ROHX-MR5	R		1,5	2,0					
	F		0,8	1,0					

* a_p with full interference 25 % of Ø DC maximum!



Torus inserts									
Insert Ø in mm		6	8	10	12	16	20	25	32
		$a_{p \max.}$	$a_{p \max.}$	$a_{p \max.}$	$a_{p \max.}$	$a_{p \max.}$	$a_{p \max.}$	$a_{p \max.}$	$a_{p \max.}$
XOHX-FM5	R		2,0	3,0	3,0	4,0	5,0	6,0	8,0
	F		0,6	2,0	2,4	3,2	4,0	5,0	6,4
XOHX-MR6	R		2,0	3,0	3,0	4,0	5,0	6,0	8,0
	F		0,6	2,0	2,4	3,2	4,0	5,0	6,4
XOHX-FM1	R			1,5	2,0	3,0	4,0		
	F			0,8	0,8	1,0	1,0		
XOHX-FM2	R		1,0	1,5	2,0	3,0	4,0	5,0	
	F		0,5	0,7	0,8	1,0	1,0	1,5	
XOHX-MR2	R	0,8	1,0	1,5	2,0	3,0	4,0	5,0	
	F	0,5	0,5	0,7	0,8	1,0	1,0	1,5	
XOGX-MF4	R			1,5	2,0	3,0	4,0		
	F			0,7	0,8	1,0	1,0		
XOHX-MR3	R			0,5	0,6	0,8	1,0		
	F								

Ranges of application of geometry

Inserts	F	M	R	Main Application
XOHX-FM1	•	•		Steel, steel casting, heat resistant steel, hardened steel to 63 HRc
XOHX-FM2	•	•		Steel, steel casting, heat resistant steel, hardened steel to 60 HRc
ROHX-FM3	•	•		Steel, steel casting, heat resistant steel
ROHX-FM4	•	•		Steel, steel casting, heat resistant steel, hardened steel to 60 HRc
XOHX-FM5	•	•		Steel, steel casting, heat resistant steel, hardened steel to 60 HRc
ROHX-FM6	•	•	•	Non ferrous metals, plastics, graphite
XOHX-MR2		•	•	long-chipping ferrous metals
XOHX-MR3		•	•	Steel, steel casting, heat resistant steel
ROGX-MR4		•	•	Steel, steel casting, heat resistant steel
XOGX-MF4	•	•		Steel, steel casting, heat resistant steel
ROHX-MR5		•	•	long-chipping ferrous metals
XOHX-MR6		•	•	long-chipping ferrous metals

Cutting data standard values for MaxiMill Slot-SX saws

Index	CTCP335	CTP1340	H216T
	v _c in m/min.		
P.1.1	240	190	
P.1.2	210	160	
P.1.3	180	140	
P.1.4	160	130	
P.1.5	140	120	
P.2.1	220	170	
P.2.2	160	130	
P.2.3	140	120	
P.2.4	100	80	
P.3.1	130	120	
P.3.2	110	100	
P.3.3	90	80	
P.4.1	140	120	
P.4.2	120	110	
M.1.1	110	130	
M.2.1	100	120	
M.3.1	80	100	
K.1.1	300	200	140
K.1.2	240	180	115
K.2.1	200	120	150
K.2.2	160	100	110
K.3.1	190	120	170
K.3.2	160	100	140
N.1.1		300	500
N.1.2		200	330
N.2.1		250	370
N.2.2		220	330
N.2.3		200	280
N.3.1		300	350
N.3.2		300	350
N.3.3		200	320
N.4.1		200	320
S.1.1		70	
S.1.2		60	
S.2.1		35	
S.2.2		25	
S.2.3		30	
S.3.1		60	
S.3.2		50	
S.3.3		40	
H.1.1			
H.1.2			
H.1.3			
H.1.4			
H.2.1			
H.3.1			
O.1.1			160
O.1.2			
O.2.1			240
O.2.2			
O.3.1			

average chip thickness Feed per tooth Feed rate

h_m in mm f_z in mm v_f in mm/min

$$h_m = f_z \sqrt{\frac{a_e}{DC}}$$

$$f_z = h_m \sqrt{\frac{DC}{a_e}}$$

$$v_f = f_z \times ZNF \times n$$

DC = Ø of the disc cutters

ZNF = Number of teeth of the cutter

Reference tool 50 386 12504 – ASLOT.125.R.8.32.DC-SX4

	SX4 -F2				SX4 -M1				SX4 -M7			
	a _e	10	20	30	a _e	10	20	30	a _e	10	20	30
	hm	f _z in mm			hm	f _z in mm			hm	f _z in mm		
P	0,08	0,28	0,20	0,16	0,1	0,30	0,25	0,20	0,09	0,30	0,23	0,18
M	0,05	0,18	0,13	0,10					0,06	0,21	0,15	0,12
K					0,12	0,30	0,30	0,24	0,09	0,30	0,23	0,18
N	0,08	0,28	0,20	0,16								
S	0,04	0,14	0,10	0,08								
H												
O												

Reference tool 50 386 12504 – ASLOT.125.R.8.32.DC-SX4

	SX4 -M8				SX4 -27P			
	a _e	10	20	30	a _e	10	20	30
	hm	f _z in mm			hm	f _z in mm		
P	0,08	0,28	0,20	0,16				
M	0,05	0,18	0,13	0,10				
K					0,06	0,21	0,15	0,12
N	0,08	0,28	0,20	0,16	0,09	0,30	0,23	0,18
S	0,04	0,14	0,10	0,08				
H								
O					0,05	0,18	0,13	0,10

Caution: For narrower and wider indexable inserts, reduce or increase the feed per tooth accordingly!

The cutting data is strongly influenced by external conditions, such as the stability of the tool and workpiece clamping, material and type of machine. The specified values represent guideline cutting data that can be adjusted by approx. ±20% according to the usage conditions.

Cutting data for side and face milling cutters TX

Index	CWX500		CWK10
	v _c (m/min)	h _m (mm)	v _c (m/min)
P.1.1	160	0,10	
P.1.2	140	0,10	
P.1.3	110	0,08	
P.1.4	110	0,10	
P.1.5	90	0,08	
P.2.1	110	0,10	
P.2.2	90	0,08	
P.2.3	90	0,10	
P.2.4	80	0,08	
P.3.1	80	0,05	
P.3.2	60	0,10	
P.3.3	50	0,08	
P.4.1	100	0,05	
P.4.2	90	0,08	
M.1.1	110	0,08	
M.2.1	90	0,08	
M.3.1	70	0,08	
K.1.1	140	0,10	
K.1.2	100	0,10	
K.2.1	90	0,08	
K.2.2	80	0,05	
K.3.1	140	0,10	
K.3.2	120	0,10	
N.1.1	600	0,12	250
N.1.2	400	0,12	230
N.2.1	220	0,10	210
N.2.2	180	0,10	190
N.2.3	140	0,10	120
N.3.1	240	0,12	200
N.3.2	200	0,12	180
N.3.3	180	0,12	160
N.4.1	180	0,12	160
S.1.1	60	0,05	
S.1.2	50	0,05	
S.2.1	60	0,05	
S.2.2	50	0,05	
S.2.3	40	0,05	
S.3.1	60	0,06	
S.3.2	40	0,06	
S.3.3	30	0,06	
H.1.1			
H.1.2			
H.1.3			
H.1.4			
H.2.1			
H.3.1			
O.1.1	180	0,10	160
O.1.2	180	0,10	160
O.2.1	150	0,10	120
O.2.2	110	0,10	100
O.3.1	170	0,10	160

average chip thickness

h_m in mm

$$h_m = f_z \sqrt{\frac{a_e}{DC}}$$

Feed per tooth

f_z in mm

$$f_z = h_m \sqrt{\frac{DC}{a_e}}$$

Feed rate

v_f in mm/min

$$v_f = f_z \times ZNF \times n$$

DC = Ø of the disc cutters

ZNF = Number of teeth of the cutter

Easy and safe clamping – with the CERATIZIT power screw

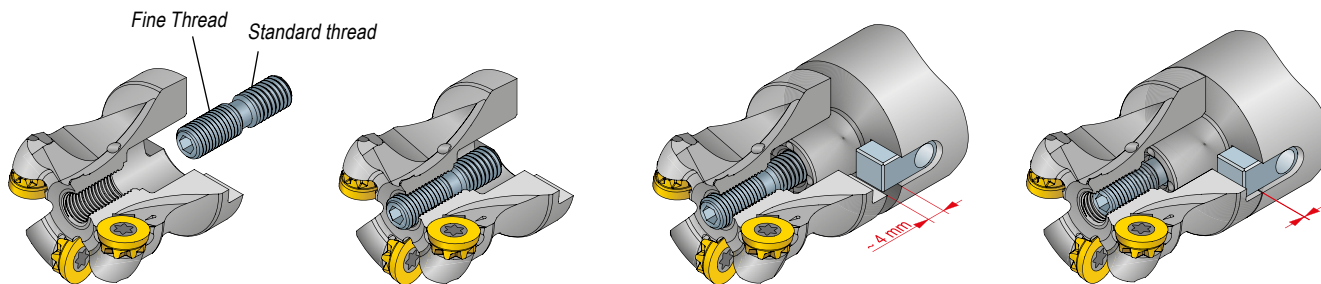

The fine-pitch part of the power screw is threaded into the milling cutter.

The power screw is turned carefully until the stop (as screw was delivered).

In order to guarantee an optimum connection of tool and shank, a gap of 4 mm is required between cutter body and adapter prior to final clamping. Using standardised adapters this is automatically guaranteed. If necessary, you can read just by means of the power screw with 0.5 mm/rev.

Turn clamping screw to tighten

Torque moments for clamping screws for mounting the milling cutter to the shell mill adapter

Cutter Ø mm	10				12				16			
	ISK-Screw DIN 912	M _d Nm	Suits- screw Article no.	M _d Nm	ISK-Screw DIN 912	M _d Nm	Suits- screw Article no.	M _d Nm	ISK-Screw DIN 912	M _d Nm	Suits- screw Article no.	M _d Nm
40			70 950 151	15			70 950 151	15				
42			70 950 151	15			70 950 151	15				
50	M10x25	80			M10x25	80					70 950 154	20
52					M10x25	80					70 950 154	20
63					M10x25	80			M10x25	80		
66					M10x25	80			M10x25	80		

Cutter Ø mm	12				16				20			
	ISK-Screw DIN 912	M _d Nm	Suits- screw Article no.	M _d Nm	ISK-Screw DIN 912	M _d Nm	Suits- screw Article no.	M _d Nm	ISK-Screw DIN 912	M _d Nm	Suits- screw Article no.	M _d Nm
80	M12x30	140			M12x30	140			M12x30	140		
100	M16x35	180			M16x35	180			M16x35	180		
125					M16x35	180			M16x35	180		

Abbreviations & dimensions

a_e	cutting width	mm
a_p	Cutting depth	mm
DC	Tool diameter	mm
D_w	Workpiece diameter	mm
f_z	Feed per tooth	mm
h_m	Average Chip Thickness	mm
k	Number of teeth	
k_c	Specific cutting force	N/mm ²
$k_{c1,1}$	Specific cutting force for 1 mm ² chip area	N/mm ²
BS	Length of trailing edge land	mm
m_c	Increase of specific cutting force	
n	rpm	rpm
Q	Chip volume	cm ³ /min
v_c	Cutting speed	m/min
v_f	Feed rate	mm/min.
ZNF	Number of Effective Teeth	
γ_0	Effective cutting angle	degree
γ_f	Side clearance angle	degree
γ_p	Axial cutting angle	degree
κ	Cutting edge angle	degree
λ_s	Angle of inclination	degree
α	Clearance angle	degree
α_1	Side clearance angle	degree

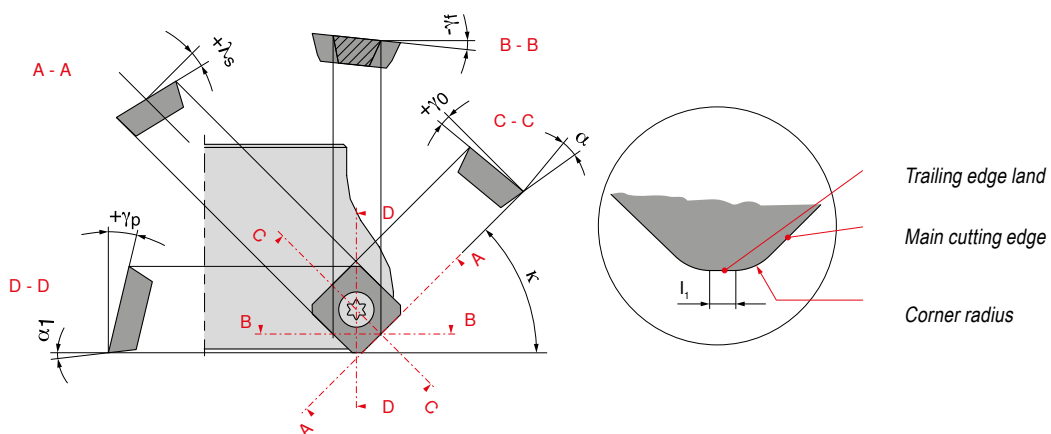
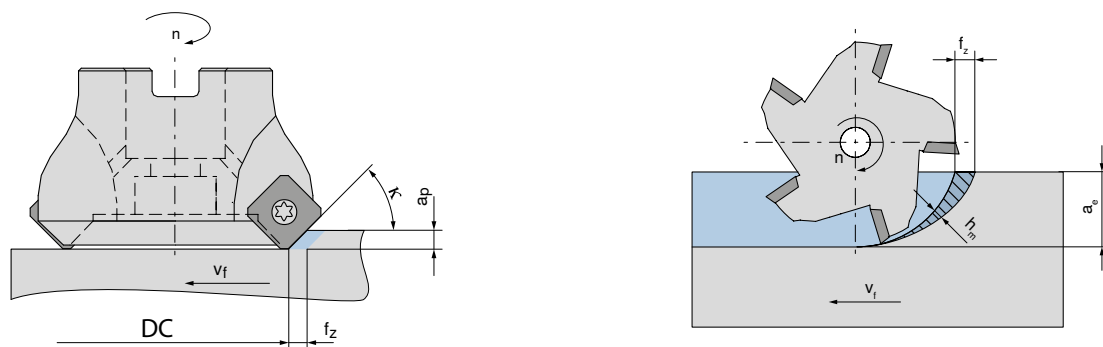

Engagement conditions

Recommended

Climb milling

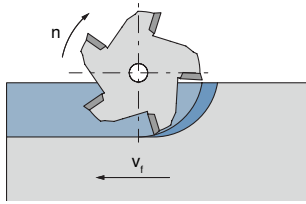

The feed direction of the workpiece is the same as the direction of rotation of the milling cutter in the cutting zone. The chips have maximum thickness at the beginning, chip thickness then decreases until it becomes zero at the end of the cut.

Unsuitable

Conventional milling

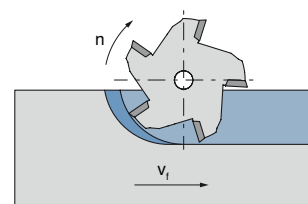

The feed direction of the workpiece is opposite to the direction of rotation of the milling cutter in the cutting zone. Chip thickness is zero at the beginning and increases until it reaches its maximum at the end of the cut.

Cutter positioning

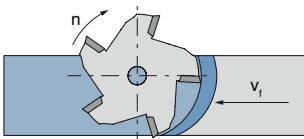

If possible the cutter should exit tangentially of the workpiece.

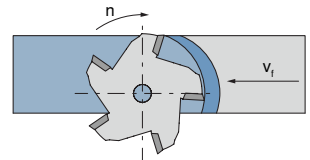

Workpiece situation

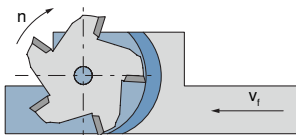

The workpiece should be clamped in such a way as to allow the cutter to emerge tangentially of the workpiece along the whole machining length.

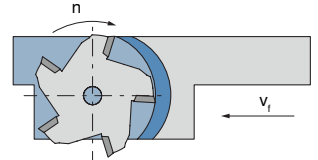

Overlapping

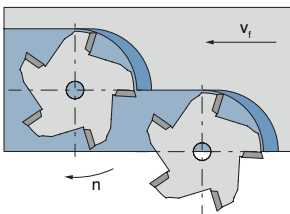

Either employ climb milling or ensure that the cutter comes out of the workpiece tangentially, as in the illustration on the left.

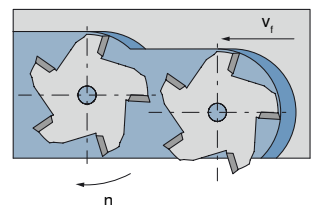

Cutter size

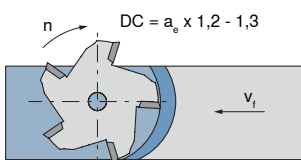

When face milling the diameter of the cutter should be 20–30 % larger than that of the workpiece.

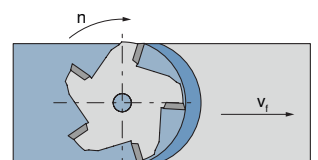

ISO designation indexable milling inserts

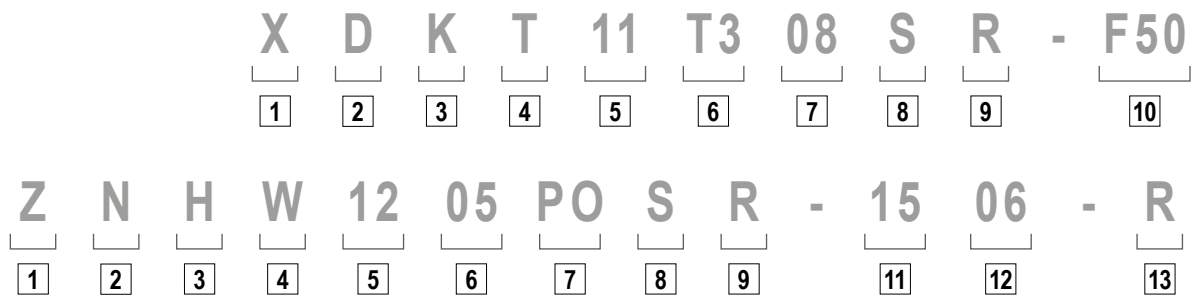

1

Insert shape

A	85°	
B	82°	
K	55°	
H	120°	
L	90°	
O	135°	
P	108°	
C	80°	
D	55°	
E	75°	
M	86°	
V	35°	
R		
S	90°	
T	60°	
W	80°	
X	Special version	
Z	Special version	

2

Clearance angle

	α
A	3°
B	5°
C	7°
D	15°
E	20°
F	25°
G	30°
N	0°
P	11°
O	Special version

3

Tolerances

	IC ±mm	BS ±mm	S ±mm	IC = 6,35 / 9,52	IC = 12,7	IC = 15,8 / 19,05
A	0,025	0,005	0,025	●	●	●
C	0,025	0,013	0,025	●	●	●
E	0,025	0,025	0,025	●	●	●
F	0,013	0,005	0,025	●	●	●
G	0,025	0,025	0,13	●	●	●
H	0,013	0,013	0,025	●	●	●
J	0,05	0,005	0,025	●	●	●
K	0,08	0,005	0,025	●	●	●
	0,10	0,005	0,025	●	●	●
M	0,05	0,08	0,13	●	●	●
	0,08	0,13	0,13	●	●	●
N	0,05	0,08	0,025	●	●	●
	0,08	0,13	0,025	●	●	●
U	0,08	0,13	0,13	●	●	●
	0,13	0,20	0,13	●	●	●
V	0,18	0,27	0,13	●	●	●
	0,18	0,27	0,13	●	●	●

7

Trailing edge land / corner radius

Radius	
	RE in mm
M0*	
02	0,2
04	0,4
08	0,8
12	1,2

* Only with insert type "R"

1. Designation	
	K_r
A	45°
D	60°
E	75°
F	85°
P	90°
Z	Alternative

2. Designation	
	α'_n
A	3°
B	5°
C	7°
D	15°
E	20°
F	25°
G	30°
N	0°
P	11°
Z	Alternative
O	Alternative

8

Cutting edge

9

Direction of cut

4

Characteristics

A	
F	
G	
M	
N	
Q	
R	
T	
U	
W	
X	Special version

5

Cutting length

IC mm											
4,90										07	
5,00						05					
5,56			05		08			03			
6,00											
6,35		11	06		10			04		06	
6,65	10										
6,80										11	
7,00											04
7,94			07								
8,00						08					
9,00					12						
9,30										15	
9,52	16	16	09		15			06	04		
9,57	15										
9,60										09	
10,00			10		11	10					12
12,00						12					
12,50										20	
12,70		12/22	12		20		22	08		12	
15,81			15		22			10			
16,00						16					
16,20				09							
16,74			16								
17,00			17								
17,18									06		
18,18									07		
19,05			19					13			
20,00						20					

6

Insert thickness



	S mm
01	1,59
T1	1,98
02	2,38
03	3,18
T3	3,97
04	4,76
05	5,56
06	6,35
07	7,94
09	9,52

10

Chip groove

Chip breaker designation
F.. = fine
M.. = medium
R.. = roughing

Additional characteristics:
R = transition radius main/
secondary cutting edge
Q = Smoothing edge

11

Manufacturer specification

Length of the finishing cutting edge

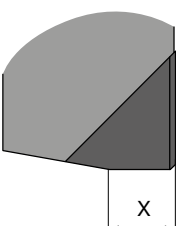

00 = 0,0 mm
10 = 1,0 mm
12 = 1,2 mm
15 = 1,5 mm
30 = 3,0 mm
50 = 5,0 mm

12

Manufacturer specification

$a_{p max}$

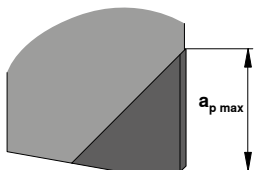

02 = 2,0 mm
03 = 3,0 mm
04 = 4,0 mm
06 = 6,0 mm
07 = 7,0 mm
11 = 11,0 mm

13

Manufacturer specification

F = Fine
M = Medium
R = Rough

Cutting demands when milling

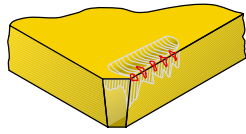
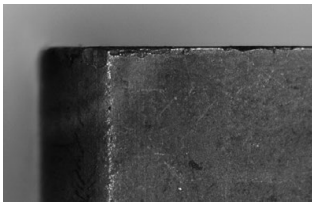

Edge chipping

Cutting speed
Feed per tooth
Toughness of grade
Cutting edge chamfer

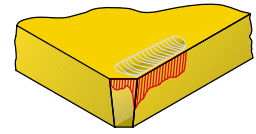

Wear on clearance face

Cutting speed
Feed per tooth
Abrasion resistant grade

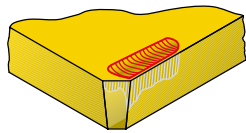
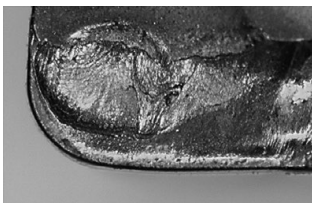

Cratering

Cutting speed
Feed per tooth
Abrasion resistant grade

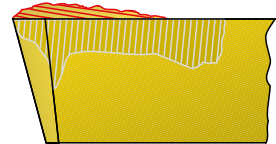
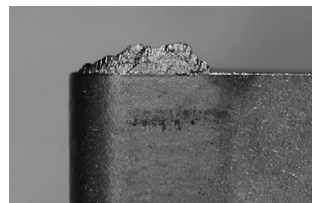

Built-up edge

Cutting speed
Feed per tooth
Wear resistance

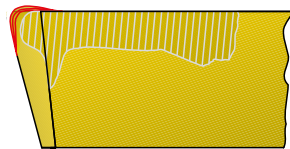
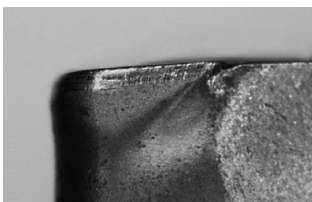

Cutting-edge deformation

Cutting speed
Feed per tooth
Abrasion resistant grade

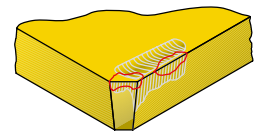
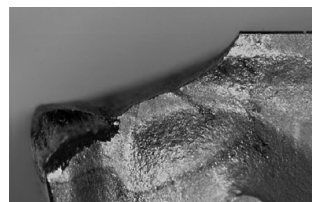

Cutting Edge Breakage

Cutting speed
Toughness of grade



Chip Breakers Overview

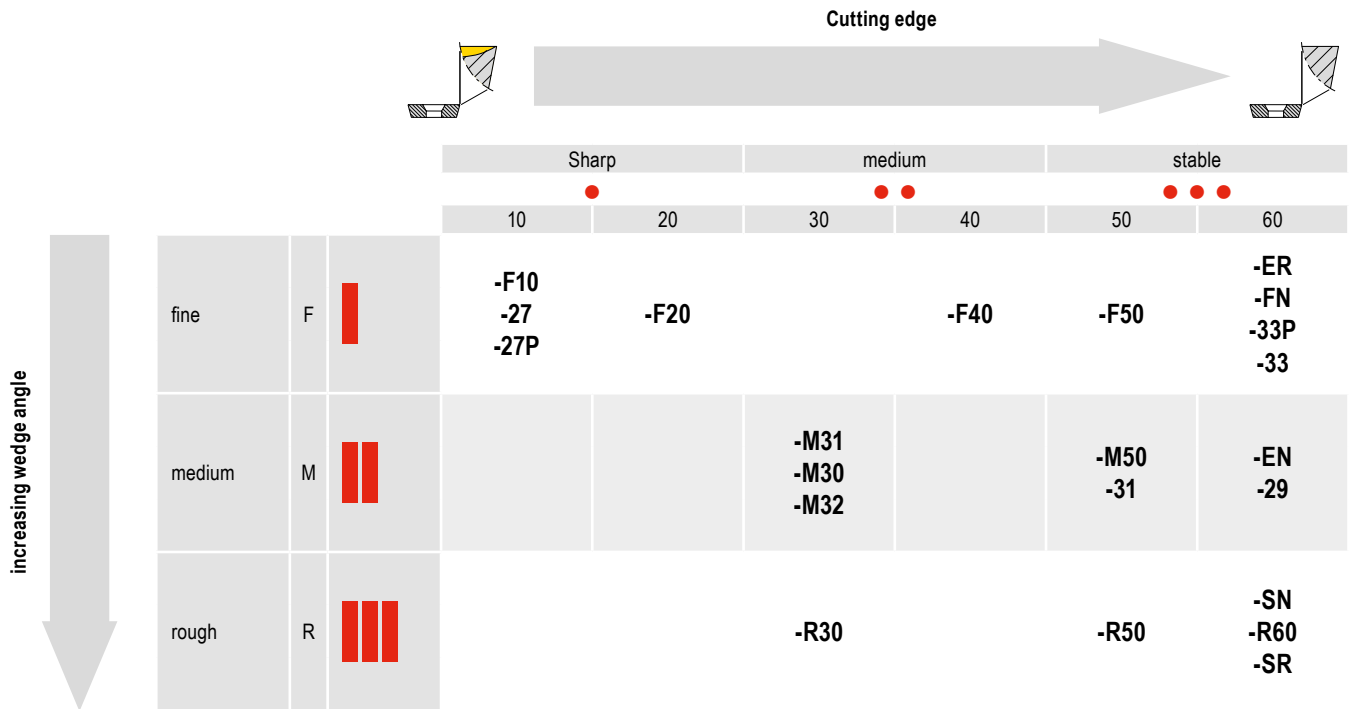

Chip breaker code

			Cutting edge		
			Sharp	medium	stable
			10-20	30-40	50-60
Application type	light	F	●	●●	●●●
	universal	M	●	●●	●●●
	difficult	R	●	●●	●●●

Example: Chip breaker -M50



Chip breaker description

-27P

- ▲ Highly positive geometry
- ▲ Ground, sharp cutting edge
- ▲ Low adhesion
- ▲ Recommendation for non-ferrous metals

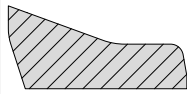

-M30

- ▲ Positive geometry
- ▲ Rounded cutting edge
- ▲ Medium rough machining
- ▲ For unstable clamping situations
- ▲ Recommendation for martensitic stainless steels (blade machining only with MaxiMill 251)

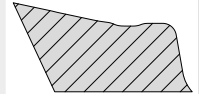

-F10

- ▲ Highly positive geometry
- ▲ Ground, sharp cutting edge
- ▲ Low adhesion
- ▲ Recommendation for non-ferrous metals

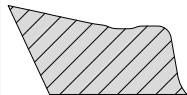

-M31

- ▲ Positive geometry
- ▲ Rounded cutting edge
- ▲ Finish and rough machining
- ▲ For unstable clamping situations
- ▲ For heat-resistant materials, titanium and super alloys

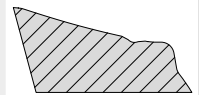

-27

- ▲ Highly positive geometry
- ▲ Sharp cutting edges
- ▲ First choice for non-ferrous metals

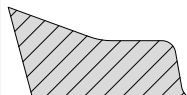

-M32

- ▲ Positive geometry
- ▲ Rounded cutting edge
- ▲ Low cutting force and good stability
- ▲ Medium rough machining
- ▲ First choice for martensitic stainless steels

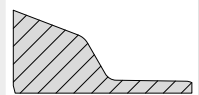

-F20

- ▲ Highly positive geometry
- ▲ Lightly rounded cutting edge
- ▲ Recommendation for non-ferrous metals

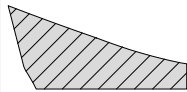

-M50

- ▲ Universal geometry with protective chamfer
- ▲ Rounded cutting edge
- ▲ Light to medium rough machining
- ▲ Recommendation for general steel materials

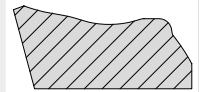

-F40

- ▲ Positive geometry
- ▲ Rounded cutting edge
- ▲ Finish and rough machining
- ▲ For unstable clamping situations
- ▲ Recommendation for heat-resistant materials, titanium and super alloys

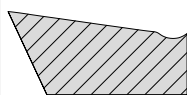

-31

- ▲ Positive geometry with neutral protective chamfer
- ▲ Rounded cutting edge
- ▲ Heavy rough machining
- ▲ Strongly interrupted cuts
- ▲ First choice for cast iron materials

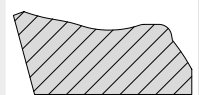

-F50

- ▲ Streamlined geometry with protective chamfer
- ▲ Rounded cutting edge
- ▲ Light rough machining
- ▲ For unstable clamping situations
- ▲ Recommendation for stainless steel materials

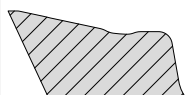

-29

- ▲ Positive geometry with slightly negative protective chamfer
- ▲ Rounded cutting edge
- ▲ Low cutting force and good stability
- ▲ Light to medium rough machining
- ▲ First choice for general steels

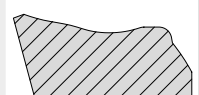

-33P

- ▲ Positive geometry with small neutral protective chamfer
- ▲ Low adhesion
- ▲ Rounded cutting edge
- ▲ Low cutting force and good stability
- ▲ For unstable clamping situations
- ▲ Light rough machining
- ▲ First choice for stainless steels

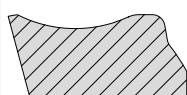

-33

- ▲ Positive geometry with small neutral protective chamfer
- ▲ Rounded cutting edge
- ▲ Low cutting force and good stability
- ▲ For unstable clamping situations
- ▲ Light rough machining
- ▲ First choice for stainless steels

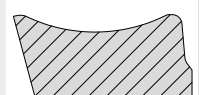

Chip breaker description

-29R

- ▲ Positive geometry with slightly negative protective chamfer
- ▲ Heavily rounded cutting edge
- ▲ Low cutting force and good stability
- ▲ Light to medium rough machining
- ▲ First choice for general steels

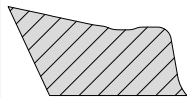

-ER

- ▲ Neutral Geometry
- ▲ Rounded cutting edge
- ▲ Universal application
- ▲ High surface quality due to face chamfer
- ▲ First choice for machining cast iron and non-ferrous metals

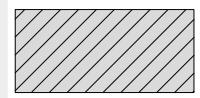

-R30

- ▲ Slightly positive geometry
- ▲ Rounded cutting edge
- ▲ Medium rough machining
- ▲ Strongly interrupted cuts
- ▲ First choice for cast iron materials

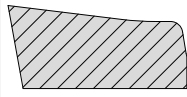

-EN

- ▲ Neutral geometry
- ▲ Rounded cutting edge
- ▲ High surface quality due to face chamfer (radial protective chamfer on indexable insert)
- ▲ First choice for machining cast iron and non-ferrous metals

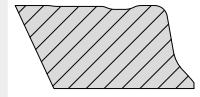

-R50

- ▲ Rugged geometry with protective chamfer
- ▲ Rounded cutting edge
- ▲ Rough machining
- ▲ Interrupted cuts
- ▲ Recommendation for cast iron materials

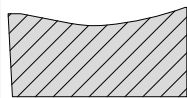

-SN

- ▲ Neutral geometry
- ▲ Rounded cutting edge
- ▲ High surface quality due to face chamfer (radial protective chamfer on indexable insert)
- ▲ Low cutting forces
- ▲ First choice for good flatness

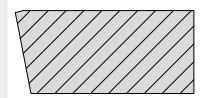

-R60

- ▲ Rugged geometry with protective chamfer
- ▲ Rounded cutting edge
- ▲ Rough machining
- ▲ For stable clamping situations
- ▲ Recommendation for high-strength steel materials

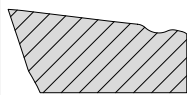

-SR

- ▲ Neutral geometry with negative protective chamfer
- ▲ Rounded cutting edge
- ▲ Robust indexable insert
- ▲ For poor machining conditions
- ▲ First choice for machining cast iron and steels

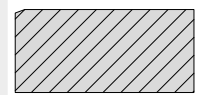

-FN

- ▲ Neutral and highly stable geometry
- ▲ Heavily rounded cutting edge
- ▲ For stable machining conditions
- ▲ First choice for hard machining up to approx. 50 HRC

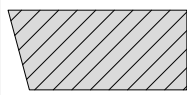

-FR

- ▲ Neutral Geometry
- ▲ Slightly rounded and stable cutting edge
- ▲ Associated with Ceramic and CBN cutting materials.
- ▲ For stable machining situations
- ▲ First choice for machining cast irons

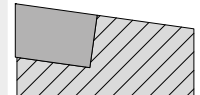

Chip breaker description for MaxiMill Slot-SX

-27P

- ▲ Positive geometry
- ▲ Ground, sharp cutting edge
- ▲ Polished chip breaker
- ▲ Low cutting forces
- ▲ Fine to medium machining
- ▲ First choice for non-ferrous metals

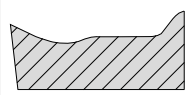

-M8

- ▲ Extremely positive geometry
- ▲ Ground cutting edge
- ▲ Low cutting forces
- ▲ Fine to medium machining
- ▲ First choice for difficult-to-machine and stainless materials
- ▲ Alternatively, can also be used for non-ferrous metals

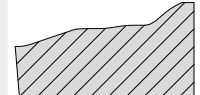

-F2

- ▲ Positive geometry
- ▲ Ground cutting edge
- ▲ Low cutting forces
- ▲ Fine to medium machining
- ▲ For stainless and steel materials

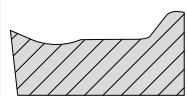

-M7

- ▲ Positive geometry
- ▲ Medium machining
- ▲ Universal application

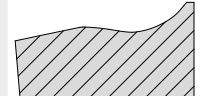

-M1

- ▲ Stable cutting edge
- ▲ Medium to rough machining
- ▲ Best suited to steel materials

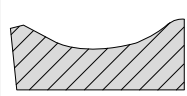

Grades Overview

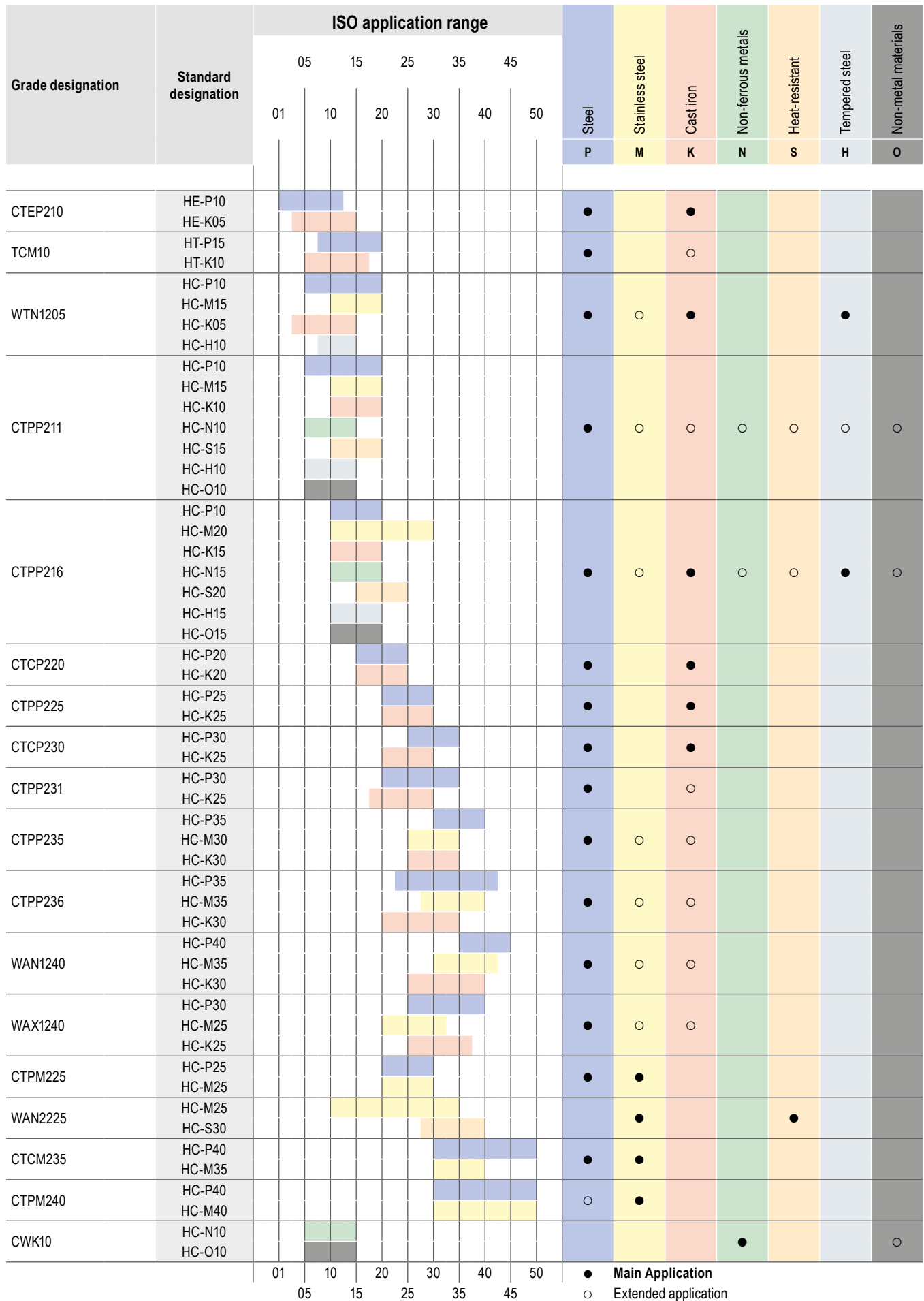

wear-resistant $v_c +$



$v_c -$ tough

Grades Overview

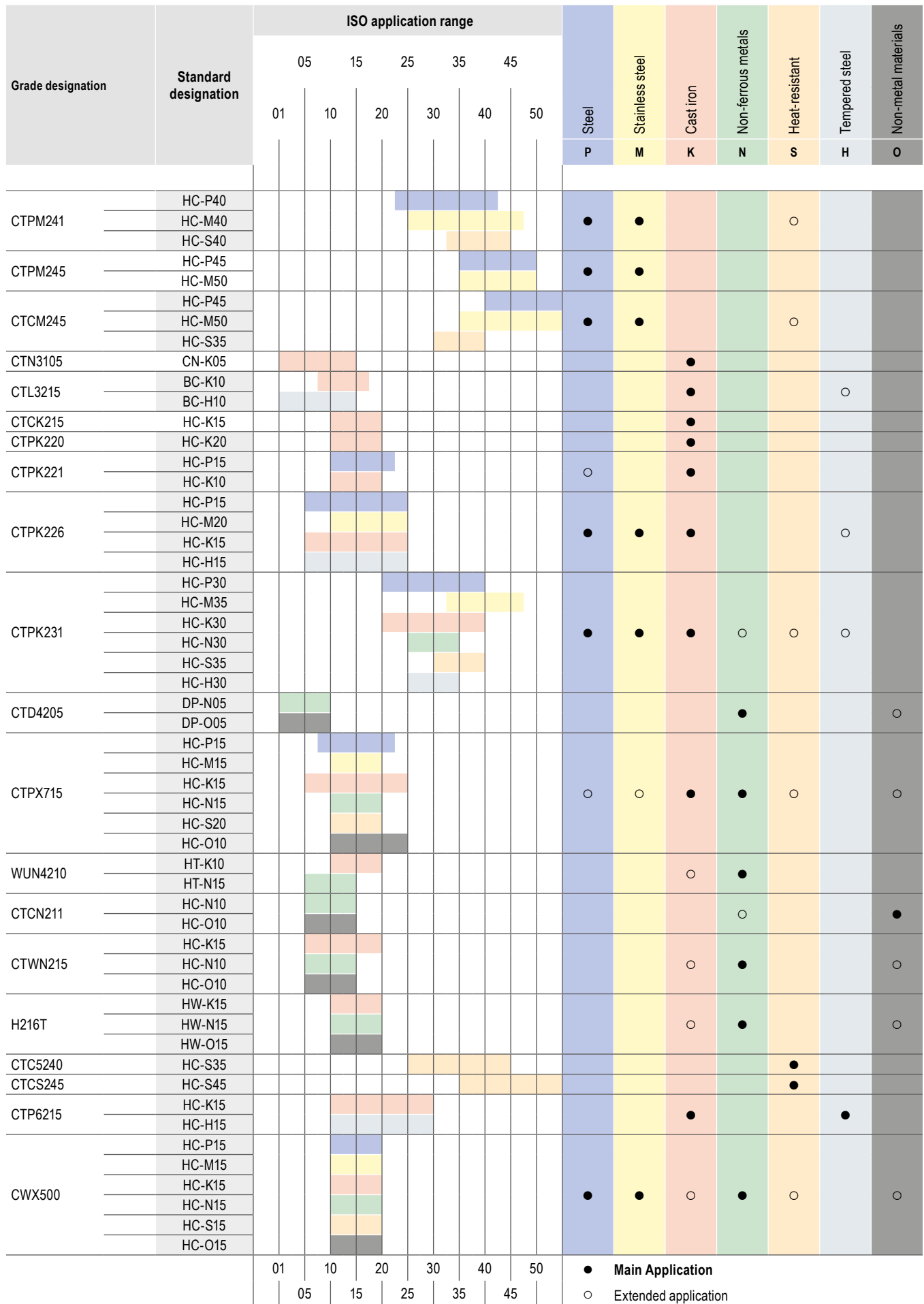

15



Grade description

CTEP210

P10 | K05

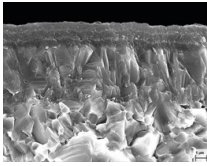
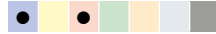

Specification:

Composition: Cermet Co/Ni 12.2%; mixed carbide 71.4%; others; WC balance | Fine grain size | Hardness: HV₃₀ 1620 | Layer system: CVD TiCN-Al₂O₃

Application:

Coated Cermet grade with reserves of toughness for finish machining at high cutting speeds

TCM10

P15 | K10



Specification:

Composition: Co/Ni 12.2%; WC 15; TaNbC10.0%; TiCn balance | Hardness: HV₃₀ 1620 | Layer system: uncoated

Application:

Uncoated Cermet grade for the finishing of hardened steel

CTN3105

CN-K05

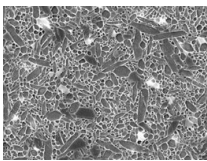
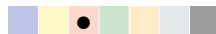

Specification:

Composition: β - Si₃N₄ | Fine grain size | Hardness: HV₃₀ 1620 | Layer system: uncoated

Application:

Universal silicon nitride for the machining of cast iron materials

CTL3215

BC-K10 | BC-H10

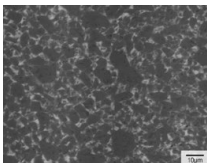
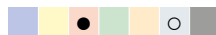

Specification:

Composition: Cubic boron nitride (CBN) | 85 vol. + metallic binder phase | Cutting system: PVD

Application:

Coated cubic boron nitride with very good cutting toughness and good wear resistance for the machining of cast iron materials

CTCP220

HC-P20 | HC-K20

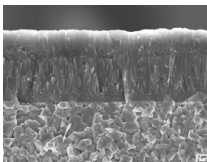
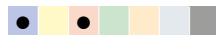

Specification:

Composition: Co 8.0%; mixed carbide 2.0%; WC balance | Medium grain size 1-2µm | Hardness: HV₃₀ 1500 |

Layer system: CVD TiCN-Al₂O₃

Application:

Dry machining, high cutting speed + more wear resistant grades to CTCP230

Material example:

Low material strength up to approx. 250 HB / 840 N/mm²

CTPP225

HC-P25 | HC-K25

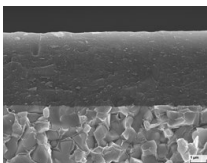
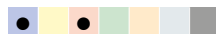

Specification:

Composition: Co 8.0%; mixed carbide 2.0%; WC balance | Medium grain size 1-2µm | Hardness: HV₃₀ 1500 | Layer system: PVD TiAlTaN

Application:

Dry or wet machining, face milling of steel materials, higher cutting speeds + more wear resistant grades to CTPP235

Material example:

Medium material strength up to approx. 300 HB / 1000 N/mm²

CTCP230

HC-P30 | HC-M25 | HC-K25

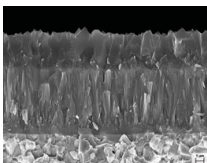
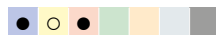

Specification:

Composition: Co 10.5%; mixed carbide 2.0%; WC balance | Medium grain size 1-2µm | Hardness: HV₃₀ 1400 |

Layer system: CVD TiCN-Al₂O₃

Application:

Dry machining, universal grade for higher cutting speeds

CTPP235

HC-P35 | HC-M30

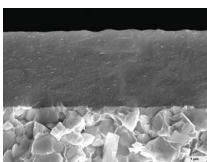
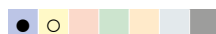

Specification:

Composition: Co 10.5%; mixed carbide 2.0%; WC balance | Medium grain size 1-2µm | Hardness: HV₃₀ 1400 | Layer system: PVD TiAlTaN

Application:

Wet machining, universal grade for medium cutting speeds

Grade description

CTPM225

HC-P25 | HC-M25

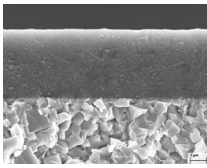
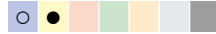

Specification:

Composition: Co 9.0%; mixed carbide 0.75%; WC balance | Fine grain size 0.7-1µm | Hardness: HV₃₀ 1590 | Layer system: PVD TiAlTaN

Application:

Dry or wet machining at medium cutting speeds

Material example:

Austenitic stainless steels

CTCM235

HC-P40 | HC-M35

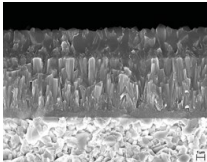
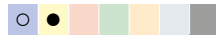

Specification:

Composition: Co 12.5%; mixed carbide 2.0%; WC balance | Fine grain size 1µm | Hardness: HV₃₀ 1380 | Layer system: CVD TiCN-Al₂O₃

Application:

Dry machining for medium cutting speeds

Material example:

Martensitic stainless steels

CTPM240

HC-P40 | HC-M40

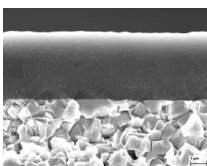
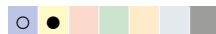

Specification:

Composition: Co 12.0%; mixed carbide 2.0%; WC balance | Fine grain size 1µm | Hardness: HV₃₀ 1380 | Layer system: PVD TiAlTaN

Application:

Wet machining, universal grade for higher cutting speeds

Material example:

Austenitic stainless steels

CTPM245

HC-P45 | HC-M45

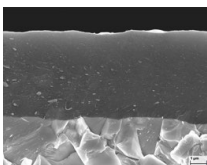
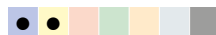

Specification:

Composition: Co 10.0%; others 1.5%; WC balance | Medium grain size 1-2µm | Hardness: HV₃₀ 1330 | Layer system: PVD TiAlTaN

Application:

Dry or wet machining

Material example:

High-alloy martensitic and austenitic stainless steel

CTCM245

HC-P45 | HC-M50 | HC-S35

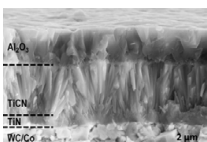
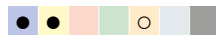

Specification:

Composition: Co 10.0%; others 1.5%; WC balance | Medium grain size 1-2µm | Hardness: HV₃₀ 1330 | Layer system: CVD TiCN-Al₂O₃

Application:

Dry machining

Material example:

High-alloy martensitic and austenitic stainless steel

CTCK215

HC-K15

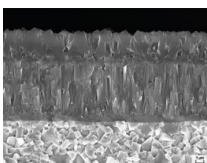
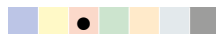

Specification:

Composition: Co 6.0%; mixed carbide 2.0%; WC balance | Fine grain size 1µm | Hardness: HV₃₀ 1630 | Layer system: CVD TiCN-Al₂O₃

Application:

Special grade for the dry machining of cast iron materials at high cutting speeds

Material example:

Cast iron materials such as GG25 and GGG40

CTPK220

HC-K20

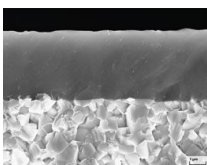
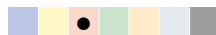

Specification:

Composition: Co 6.0%; mixed carbide 2.0%; WC balance | Fine grain size 1µm | Hardness: HV₃₀ 1630 | Layer system: PVD TiAlTaN

Application:

Special grade for the wet machining of cast iron materials in demanding application ranges

Material example:

High-strength cast iron materials such as GGG50 and GGG70

CTD4205

DP-N05

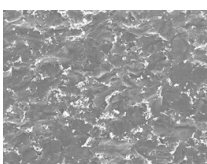

Specification:

Composition: Polycrystalline diamond (PKD) | grain size 2-5µm | Layer system: uncoated

Application:

For the machining of aluminium and non-ferrous metals

Material example:

Non-ferrous metals such as AlMgSi1

Grade description

CTWN215 (H216T)

K15 | N15 | O15

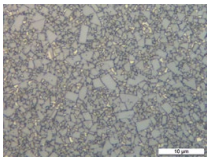

Specification:

Composition: Co 6.0%; WC balance | Fine grain size 1µm | Hardness: HV₃₀ 1650 | Layer system: uncoated

Application:

Uncoated carbide for the machining of aluminium and non-ferrous metals

Material example:

Non-ferrous metals such as AlMgSi1

CTPX715

ISO | P15 | M15 | K15 | N15 | S20 | O10

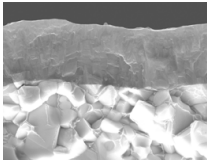

Specification:

Composition: Co 6.0%; WC balance | Fine grain size 1µm | Hardness: HV₃₀ 1650 | Layer system: PVD AlTiN

Application:

For the machining of aluminium and non-ferrous metals

Material example:

Non-ferrous metals such as AlMgSi1 or GGG30 cast iron

CTC5240

HC-S40

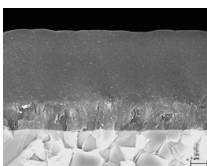

Specification:

Composition: Co 10.0%; WC balance | Medium grain size 2µm | Hardness: HV₃₀ 1330 | Layer system: CVD TiN-TiB₂

Application:

Special wet machining grade for the machining of titanium materials

Material example:

Titanium Ti6Al4V

CTCS245

HC-S45

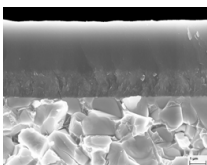

Specification:

Composition: Co 12.0%; mixed carbide 1.8%; WC balance | Medium grain size 1-2µm | Hardness: HV₃₀ 1260 | Layer system: CVD TiN-TiB₂

Application:

Wet machining special grade for the machining of nickel-based alloys or the dry machining of austenitic stainless steels

Material example:

Heat-resistant materials such as Inconel, Rene, Nimonic, etc.

CTP6215

HC-H15 | HC-K15

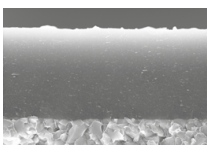

Specification:

Composition: Co 12.0%; WC balance | Ultra-fine grain size 0.4µm | Hardness: HV₃₀ 1630 | Layer system: PVD TiAlN

Application:

For the machining of high-strength martensitic tool steels 400HB / 1300 N/mm²

Material example:

Tool steel 1.2379, 1.2312

CTPK231

P30 | M35 | K30 | N30 | S35 | H30

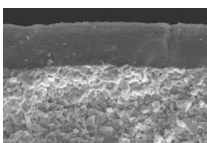

Specification:

Composition: Co 9.8%; WC balance | Fine grain size 1µm | Hardness: HV₃₀ 1612 | Layer system: PVD TiN / TiAlN / ZS / TiAlN / Al₂O₃ / TiN

Application:

Dry machining, tough carbide grade for the medium and rough machining of steel and cast iron metals

CTPP216

P10 | M20 | K15 | N15 | S20 | H15 | O15

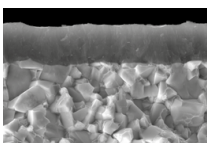

Specification:

Composition: Co 9.6%; WC balance | Fine grain size 0,7-1µm | Hardness: HV₃₀ 1824 | Layer system: PVD TiN / TiAlN / DS

Application:

Highly wear-resistant carbide grade with high cutting edge stability for the machining of high-strength materials, non-alloyed tool steels, cast iron and hardened steel up to 54 HRC

CTPK226

P10 | M20 | K15 | H15

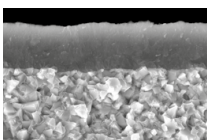

Specification:

Composition: Co 11.6%; WC balance | Fine grain size 0.7-1µm | Hardness: HV₃₀ 1711 | Layer system: PVD TiN / AlTiN / DS

Application:

Highly wear-resistant ultra-fine grain carbide grade for the machining of cast iron metals and hardened steels up to 62 HRC

Grade description

CTCN211

N10 | O15

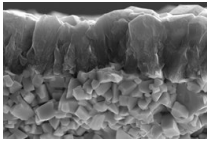
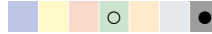

Specification:

Composition: Co 6.5%; WC balance | Fine grain size 0.7-1µm | Hardness: HV₃₀ 1827 | Layer system: PVD diamond

Application:

Diamond-coated carbide grade for the machining of graphite and non-ferrous metals

WAN1240

P40 | M35 | K30

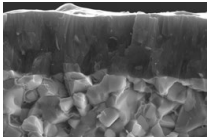

Specification:

Composition: Co 9%; mixed carbide 3.8%; WC balance | Medium grain size 1-2µm | Hardness: HV₃₀ 1449 | Layer system: PVD TiAlN / TiN

Application:

Tough special grade for the machining of steel at medium to high cutting speeds. Also suitable for the machining of cast iron in secondary applications

WAN2225

M25 | S25

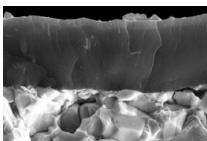

Specification:

Composition: Co 11.3%; WC balance | Medium grain size 2µm | Hardness: HV₃₀ 1307 | Layer system: PVD TiAlN / TiN

Application:

Dry and wet machining, fine grain grade with high toughness and temperature resistance. For rough and finish machining of rust and acid-resistant steels

WUN4210

K15 | N10 | O10



Specification:

Composition: Co 8.1%; WC balance | Fine grain size 0.7-1µm | Hardness: HV₃₀ 1715 | Layer system: uncoated

Application:

Uncoated carbide for the machining of aluminium and non-ferrous metals

Material example:

Non-ferrous metals such as AlMgSi1

WAX1240

P40 | M25 | K30

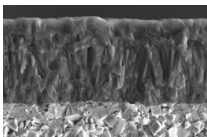
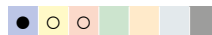

Specification:

Composition: Co 10.5%; mixed carbide 2.1%; WC balance | Medium grain size 1-2µm | Hardness: HV₃₀ 1345 |

Layer system: CVD TiN / TiCN / TiN / Al₂O₃

Application:

High-strength special grade for medium and rough machining at medium cutting speeds and extreme feed rates per tooth

WTN1205

P10 | M15 | K05 | H10

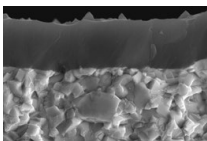

Specification:

Composition: Co 7.3%; WC balance | Fine grain size 0.7-1µm | Hardness: HV₃₀ 1801 | Layer system: PVD TiN / TiAlN

Application:

Special grade for the machining of steel, hardened steel, cast iron, and non-ferrous metals and graphite

CTPP231

P30 | K25

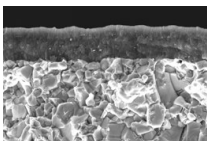
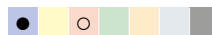

Specification:

Composition: Co 9.5%; mixed carbide 2%; WC balance | Medium grain size 2-3µm | Hardness: HV₃₀ 1400 | Layer system: PVD TiAlN

Application:

A very tough special grade for the medium and rough machining of steel at medium cutting speeds and extremely high feed rates

CTPP211

P10 | M15 | K10 | N10 | S15 | H10 | O10

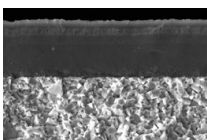

Specification:

Co 6.3%; WC balance | Fine grain size 0.7-1µm | Hardness: HV₃₀ 1843 | Layer system: PVD TiN / TiAlN / ZS / TiAlN / Al₂O₃ / ZS / TiN

Application:

universal grade for medium cutting speeds

Grade description

CTPP236

P35 | M35 | K30

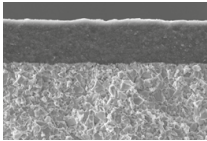
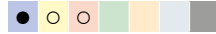

Specification:

Composition: Co 9.5%; mixed carbide 2%; WC balance | Medium grain size 2-3µm | Hardness: HV₃₀ 1370 | Layer system: PVD TiAlN

Application:

Tough special grade for the medium and rough machining of steel at high cutting speeds. Also suitable for the machining of cast iron and stainless steels in secondary applications

CTPK221

P15 | K10

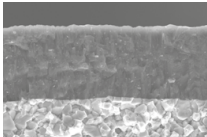
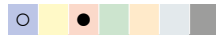

Specification:

Composition: Co 6%; WC balance | Medium grain size 1µm | Hardness: HV₃₀ 1600 | Layer system: PVD TiAlN

Application:

Standard grade for the fine machining of cast iron and non-ferrous metals at medium cutting speeds

CTPM241

P40 | M40 | S40

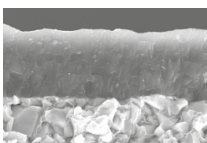
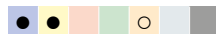

Specification:

Composition: Co 12%; WC balance | Medium grain size 1-2µm | Hardness: HV₃₀ 1450 | Layer system: PVD TiAlN

Application:

Tough special grade for the machining of stainless and heat-resistant steels

CTP1340

ISO | P30 | K30 | N30 | S30 | O30

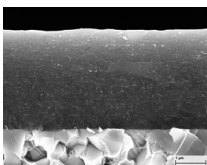
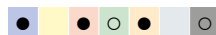

Specifications:

Composition: Co 9.0%; mixed carbide 0.75%; WC balance | grain size: 0.7-1 µm | Hardness: HV₃₀ 1590 | Layer system: PVD TiAlTaN

Recommended use:

The universal high-performance grade for steels, austenitic steel, cast iron materials and heat-resistant alloys

CTCP335

ISO | P35 | M30 | K35

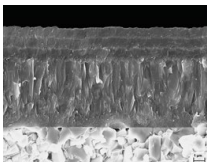
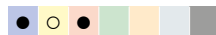

Specifications:

Composition: Co 10.5%; mixed carbide 1.9%; WC balance | grain size: 1 µm | Hardness: HV₃₀ 1370 |

Layer system: CVD TiCN-Al₂O₃ Multilayer

Recommended use:

The reliable choice for machining steel and cast iron materials.

CWK10

N10 | O10

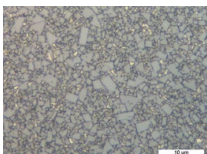

Specification:

Composition: Co 6.0%; WC balance | Fine grain size 1µm | Hardness: HV₃₀ 1650 | Layer system: uncoated

Application:

Uncoated carbide for the machining of aluminium and non-ferrous metals

Material example:

Non-ferrous metals such as AlMgSi1

CWX500

ISO | P30 | M30 | K35 | N35 | S15 | H05 | O10

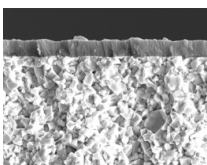

Specification:

Composition: Co 10.0%; Others 0.7 %, WC balance | Grain size: 1 µm | Hardness: HV₃₀ 1660

Recommended application:

The universal carbide grade for almost all materials

Grade description

C T C P 2 2 0 (Example)

CT
CERATIZIT

Coating

W Uncoated carbide	S Mixed ceramic
C CVD-coated carbide	K Whisker ceramic
P PVD-coated carbide	I SiAlON
T Cermet, uncoated	D PDC
E Cermet, coated	B PcBN
N Silicon nitride, uncoated	L PcBN coated
M Silicon nitride, coated	H HSS sintered

Main application – material

P Steel
M Stainless steel
K Cast iron
N Non-ferrous metals
S Heat-resistant
H Tempered steel
O Non-metal materials
X Universal application

Application

1 Turning
2 Milling
3 Grooving
4 Drilling
5 Thread turning
6 Others
7 Several processes

Degree of hardness

05	ISO 05
10	ISO 10
15	ISO 15
20	ISO 20
25	ISO 25
30	ISO 30
35	ISO 35
40	ISO 40

