

Solid drilling and bore machining

- 1 HSS drilling
- 2 Solid carbide drilling
- 3 Indexable insert drilling
- 4 Reaming and Countersinking
- 5 Spindle Tooling

Threading

- 6 Taps and thread formers
- 7 Circular and Thread Milling
- 8 Thread turning

8

Turning

- 9 Turning Tools
- 10 Multifunctional Tools – EcoCut and FreeTurn
- 11 Grooving Tools
- 12 Miniature turning tools

Milling

- 13 HSS Milling Cutters
- 14 Solid Carbide milling cutters
- 15 Milling tools with indexable inserts

Clamping technology

- 16 Adaptors and Accessories
- 17 Workpiece clamping

- 18 Material examples and article no. Index

Table of contents

Symbol explanation	5
Toolfinder	4+5
Product programme	6-42
Shims	43
Technical Information	
Cutting Data	44+45
Thread turning methods	46
Pitch angle	47
Designation Key	48+49
Troubleshooting	50
Grade description and profile explanation	51

WNT \ Performance

Premium quality tools for high performance.

The premium quality tools from the **WNT Performance** product line have been designed for specific applications and are distinguished by their outstanding performance. If you make high demands on the performance of your production and want to achieve the very best results, we recommend the Premium tools in this product line.

Toolfinder

MiniCut

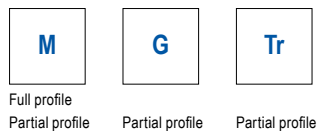

→ Chapter 12 – Miniature turning tools

UltraMini

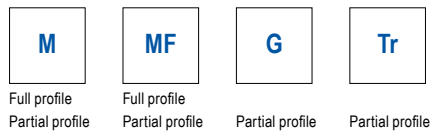

→ Chapter 12 – Miniature turning tools

VertiClamp

→ Sliding head tooling catalogue

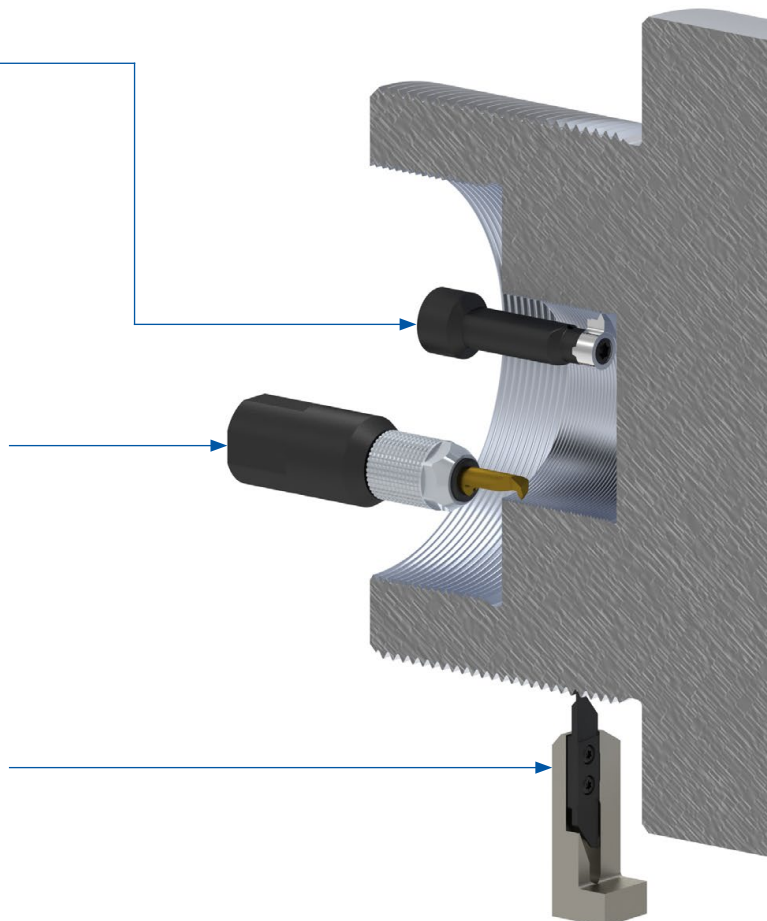

Symbol explanation

Flank angle

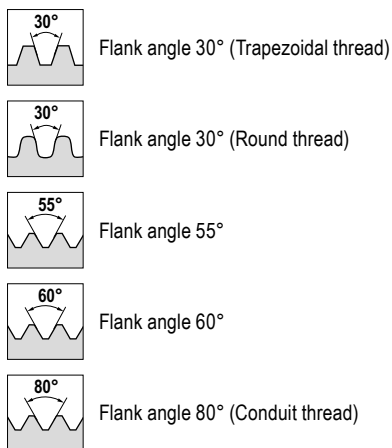

- TP / TPI = Pitch
- NT = Number of flutes
- = Main Application
- = Extended application

Thread

M	ISO metric coarse thread DIN 13	UNEF	American unified thread (extra fine) BS 1580 (ASME B 1.1)
MF	ISO Metric fine thread DIN 13	NPT	American pipe thread ANSI/ASME B 1.20.3
BSW	British Whitworth thread BS 84	Tr	Trapezoidal thread DIN 103
UN	American unified thread BS 1580 (ASME B 1.1)	Rd	Round Thread DIN 405
UNC	American unified thread (coarse) BS 1580 (ASME B 1.1)	Pg	Conduit Threads DIN 40430
UNF	American unified thread (fine) BS 1580 (ASME B 1.1)		

Standard external thread turning

Full profile

M	BSW	UN	UNC	UNF	UNEF	NPT	Tr	Rd	Pg
6+7	11+12	15+16	15+16	15+16	15+16	19	21	24	26

Partial profile

60°	55°	M
28	30	10

Multi-cutting edge

Suitable holders can be found on → page 32+33

Standard internal thread turning

Full profile

M	BSW	UN	UNC	UNF	UNEF	NPT	Tr	Rd	Pg
8+9	13+14	17+18	17+18	17+18	17+18	20	22	25	27

Partial profile

60°	55°
29	31

Suitable holders can be found on → page 34–36

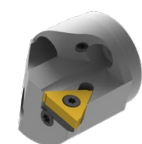

Internal threading with MaxiChange – our exchangeable head system

→ Chapter 9 – Turning Tools

Mini 06

Full profile

M	BSW	M
37	37	39

Partial profile

60°	55°	60°	55°
38	38	39+40	40+41

Suitable holders can be found on → page 42

Information on the different thread profiles can be found on → Page 51.

Right hand external thread turning insert

▲ Full profile

▲ CCN7525 grade with sintered chip breaker for universal application

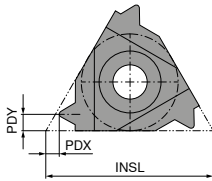
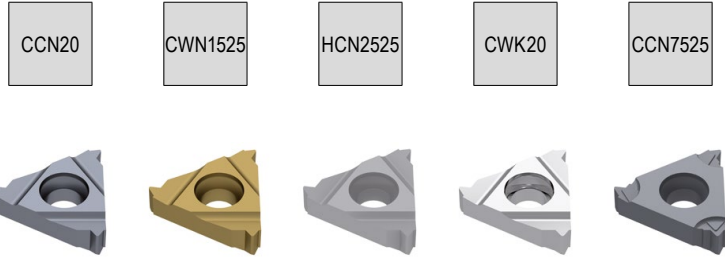

Designation	TP mm	INSL mm	PDX mm	PDY mm	ER 71 220 ...		ER 71 220 ...		ER 71 220 ...		ER 71 220 ...		ER 71 220 ...	
					EUR X3		EUR X3		EUR X3		EUR Y1		EUR X3	
11 ER 0,35	0,35	11	0,8	0,4	23,72	204								
11 ER 0,4	0,40	11	0,7	0,4	23,72	206								
11 ER 0,45	0,45	11	0,7	0,4	23,72	208								
11 ER 0,5	0,50	11	0,6	0,6	23,72	209								
11 ER 0,6	0,60	11	0,6	0,6	23,72	210								
11 ER 0,7	0,70	11	0,6	0,6	23,72	211								
11 ER 0,75	0,75	11	0,6	0,6	23,72	212								
11 ER 0,8	0,80	11	0,6	0,6	23,72	213								
11 ER 1,0	1,00	11	0,7	0,7	22,17	214								
11 ER 1,25	1,25	11	0,8	0,9	22,17	216								
11 ER 1,5	1,50	11	0,8	1,0	22,17	218								
11 ER 1,75	1,75	11	0,8	1,1	22,17	220								
16 ER 0,35	0,35	16	0,8	0,4	23,72	234		28,84	734	15,49	634			
16 ER 0,4	0,40	16	0,7	0,4	23,72	236		28,84	736	15,49	636			
16 ER 0,45	0,45	16	0,7	0,4	23,72	238				15,49	638			
16 ER 0,5	0,50	16	0,6	0,6	23,72	240	19,91	140	21,87	740	15,49	640	21,87	940
16 ER 0,7	0,70	16	0,6	0,6	23,72	241	21,32	141	23,16	741	15,49	641		
16 ER 0,75	0,75	16	0,6	0,6	23,72	242	19,91	142	21,87	742	15,49	642	21,87	942
16 ER 0,8	0,80	16	0,6	0,6	23,72	243	19,91	143	21,87	743	15,49	643	21,87	943
16 ER 1,0	1,00	16	0,7	0,7	22,17	244	19,19	144	21,32	744	13,98	644	21,32	944
16 ER 1,25	1,25	16	0,8	0,9	22,17	246	19,19	146	21,32	746	13,98	646	21,32	946
16 ER 1,5	1,50	16	0,8	1,0	22,17	248	19,19	148	21,32	748	13,98	648	21,32	948
16 ER 1,75	1,75	16	0,9	1,2	22,17	250	19,19	150	21,32	750	13,98	650		
16 ER 2,0	2,00	16	1,0	1,3	22,17	252	19,19	152	21,32	752	13,98	652	21,32	952
16 ER 2,5	2,50	16	1,1	1,5	22,17	254	19,19	154	21,32	754	13,98	654	21,32	954
16 ER 3,0	3,00	16	1,2	1,6	22,17	256	19,19	156	21,32	756	13,98	656	21,32	956
22 ER 3,5	3,50	22	1,6	2,3	33,24	270	29,84	170	32,82	770				
22 ER 4,0	4,00	22	1,6	2,3	33,24	272	31,40	172	33,96	772				
22 ER 4,5	4,50	22	1,7	2,4	33,24	274	33,66	174	36,63	774				
22 ER 5,0	5,00	22	1,7	2,5	33,24	276	33,66	176	36,63	776				
22 ER 5,5	5,50	22	1,7	2,6			33,66	178						
22 ER 5,5	5,50	22	1,9	2,7	33,24	278								
22 EN 5,5	5,50	22	2,3	11,0	41,91	282 ¹⁾								
22 ER 6,0	6,00	22	1,9	2,7			33,66	180	36,63	780				
22 ER 6,0	6,00	22	2,0	2,9	33,24	280								
22 EN 6,0	6,00	22	2,6	11,0	41,91	284 ¹⁾								

P	●	●	○	●
M	●	○	●	○
K	●	●	○	●
N		●	○	●
S	○		○	●
H	○		○	○
O		○		

1) Neutral version (N) – for right and left hand thread applications. Neutral Toolholder marked (U) is required. → v_c Page 45

Left hand external thread turning insert

▲ Full profile

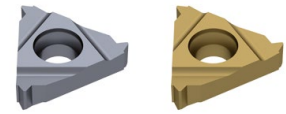
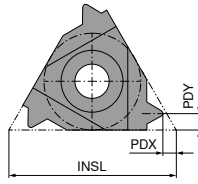

Designation	TP mm	INSL mm	PDX mm	PDY mm	EL	
					71 222 ... EUR X3	71 222 ... EUR X3
11 EL 0,35	0,35	11	0,8	0,4	23,72	204
11 EL 0,4	0,40	11	0,7	0,4	23,72	206
11 EL 0,45	0,45	11	0,7	0,4	23,72	208
11 EL 0,5	0,50	11	0,6	0,6	23,72	209
11 EL 0,6	0,60	11	0,6	0,6	23,72	210
11 EL 0,7	0,70	11	0,6	0,6	23,72	211
11 EL 0,75	0,75	11	0,6	0,6	23,72	212
11 EL 0,8	0,80	11	0,6	0,6	23,72	213
11 EL 1,0	1,00	11	0,7	0,7	22,17	214
11 EL 1,25	1,25	11	0,8	0,9	22,17	216
11 EL 1,5	1,50	11	0,8	1,0	22,17	218
11 EL 1,75	1,75	11	0,8	1,1	22,17	220
16 EL 0,35	0,35	16	0,8	0,4	23,72	234
16 EL 0,4	0,40	16	0,7	0,4	23,72	236
16 EL 0,45	0,45	16	0,7	0,4	23,72	238
16 EL 0,5	0,50	16	0,6	0,6	23,72	240
16 EL 0,7	0,70	16	0,6	0,6	23,72	241
16 EL 0,75	0,75	16	0,6	0,6	23,72	242
16 EL 0,8	0,80	16	0,6	0,6	23,72	243
16 EL 1,0	1,00	16	0,7	0,7	22,17	244
16 EL 1,25	1,25	16	0,8	0,9	22,17	246
16 EL 1,5	1,50	16	0,8	1,0	22,17	248
16 EL 1,75	1,75	16	0,9	1,2	22,17	250
16 EL 2,0	2,00	16	1,0	1,3	22,17	252
16 EL 2,5	2,50	16	1,1	1,5	22,17	254
16 EL 3,0	3,00	16	1,2	1,6	22,17	256
22 EL 3,5	3,50	22	1,6	2,3	33,24	270
22 EL 4,0	4,00	22	1,6	2,3	33,24	272
22 EL 4,5	4,50	22	1,7	2,4	33,24	274
22 EL 5,0	5,00	22	1,7	2,5	33,24	276
22 EL 5,5	5,50	22	1,9	2,7	33,24	278
22 EL 6,0	6,00	22	2,0	2,9	33,24	280

P	●	●
M	●	○
K	●	●
N	●	●
S	○	○
H	○	○
O	○	○

→ v_c Page 45

Right hand internal thread turning insert

▲ Full profile

▲ CCN7525 grade with sintered chip breaker for universal application

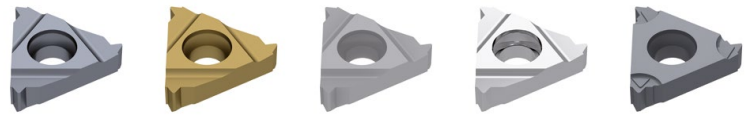
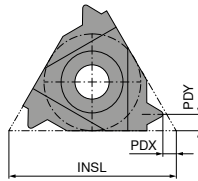
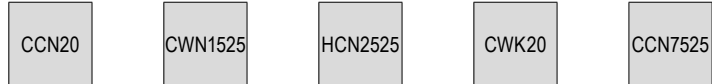

Designation	TP mm	INSL mm	PDX mm	PDY mm	IR 71 224 ...		IR 71 224 ...		IR 71 224 ...		IR 71 224 ...		IR 71 224 ...	
					EUR X3		EUR X3		EUR X3		EUR Y1		EUR X3	
11 IR 0,35	0,35	11	0,8	0,3	23,72	204								
11 IR 0,4	0,40	11	0,8	0,4	23,72	206								
11 IR 0,45	0,45	11	0,8	0,4	23,72	208								
11 IR 0,5	0,50	11	0,6	0,6	23,72	210								
11 IR 0,7	0,70	11	0,6	0,6	23,72	211								
11 IR 0,75	0,75	11	0,6	0,6	23,72	212							26,16	912
11 IR 0,8	0,80	11	0,6	0,6	23,72	213			29,55	713			21,32	914
11 IR 1,0	1,00	11	0,6	0,6										
11 IR 1,0	1,00	11	0,6	0,7	22,17	214	19,19	114	21,32	714				
11 IR 1,25	1,25	11	0,8	0,9	22,17	216								
11 IR 1,5	1,50	11	0,8	0,9									21,32	918
11 IR 1,5	1,50	11	0,8	1,0	22,17	218	19,19	118	21,32	718				
11 IR 1,75	1,75	11	0,9	1,1	22,17	220								
11 IR 2,0	2,00	11	0,8	0,9			19,19	122	21,32	722				
11 IR 2,0	2,00	11	0,9	1,1	22,17	222								
11 IR 2,5	2,50	11	0,8	1,2			21,75	124	23,72	724				
11 IR 2,5	2,50	11	0,9	1,1	22,17	224								
16 IR 0,35	0,35	16	0,8	0,4	23,72	234					15,49	634		
16 IR 0,4	0,40	16	0,7	0,4	23,72	236					15,49	636		
16 IR 0,45	0,45	16	0,7	0,4	23,72	238					15,49	638		
16 IR 0,5	0,50	16	0,6	0,6	23,72	240					15,49	640		
16 IR 0,7	0,70	16	0,6	0,6	23,72	241					15,49	641		
16 IR 0,75	0,75	16	0,6	0,6	23,72	242	23,99	142	26,16	742	15,49	642		
16 IR 0,8	0,80	16	0,6	0,6	23,72	243					15,49	643		
16 IR 1,0	1,00	16	0,6	0,7			19,19	144	21,32	744			21,32	944
16 IR 1,0	1,00	16	0,7	0,7	22,17	244					13,98	644		
16 IR 1,25	1,25	16	0,8	0,9	22,17	246			22,30	746	13,98	646	22,30	946
16 IR 1,5	1,50	16	0,8	1,0	22,17	248	19,19	148	21,32	748	13,98	648	21,32	948
16 IR 1,75	1,75	16	0,9	1,2	22,17	250			26,16	750	13,98	650		
16 IR 2,0	2,00	16	1,0	1,3	22,17	252	19,19	152	21,32	752	13,98	652	21,32	952
16 IR 2,5	2,50	16	1,1	1,5	22,17	254	19,19	154	21,32	754	13,98	654	21,32	954
16 IR 3,0	3,00	16	1,1	1,5	22,17	256	19,19	156	21,32	756	13,98	656	21,32	956
22 IR 3,5	3,50	22	1,6	2,3	33,24	270	31,40	170	33,96	770				
22 IR 4,0	4,00	22	1,6	2,3	33,24	272	31,40	172	33,96	772				
22 IR 4,5	4,50	22	1,6	2,4			33,66	174	36,63	774				
22 IR 4,5	4,50	22	1,7	2,4	33,24	274								
22 IR 5,0	5,00	22	1,6	2,3			33,66	176						
22 IR 5,0	5,00	22	1,7	2,5	33,24	276								
22 IR 5,5	5,50	22	1,6	2,3			34,10	178						
22 IR 5,5	5,50	22	1,9	2,7	33,24	278								
22 IN 5,5	5,50	22	2,3	11,0	41,91	282 ¹⁾								
22 IR 6,0	6,00	22	1,6	2,4			33,66	180						
22 IR 6,0	6,00	22	2,0	2,9	33,24	280								
22 IN 6,0	6,00	22	2,6	11,0	41,91	284 ¹⁾								
P					●		●		○				●	
M					●		○		●		○		●	
K					●		●		○		●		●	
N							●		○		●			
S					○				○		○		●	
H					○				○				○	
O								○						

1) Neutral version (N) – for right and left hand thread applications. Neutral Toolholder marked (U) is required.

Left hand internal thread turning insert

▲ Full profile

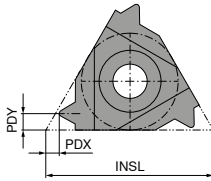
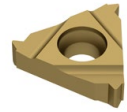
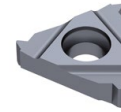

Designation	TP mm	INSL mm	PDX mm	PDY mm	IL	
					71 226 ... EUR X3	71 226 ... EUR X3
11 IL 0,35	0,35	11	0,8	0,3	23,72	204
11 IL 0,4	0,40	11	0,8	0,4	23,72	206
11 IL 0,45	0,45	11	0,8	0,4	23,72	208
11 IL 0,5	0,50	11	0,6	0,6	23,72	210
11 IL 0,7	0,70	11	0,6	0,6	23,72	211
11 IL 0,75	0,75	11	0,6	0,6	23,72	212
11 IL 0,8	0,80	11	0,6	0,6	23,72	213
11 IL 1,0	1,00	11	0,6	0,7	22,17	214
11 IL 1,25	1,25	11	0,8	0,9	22,17	216
11 IL 1,5	1,50	11	0,8	1,0	22,17	218
11 IL 1,75	1,75	11	0,9	1,1	22,17	220
11 IL 2,0	2,00	11	0,9	1,1	22,17	222
11 IL 2,5	2,50	11	0,9	1,1	22,17	224
16 IL 0,35	0,35	16	0,8	0,4	23,72	234
16 IL 0,4	0,40	16	0,7	0,4	23,72	236
16 IL 0,45	0,45	16	0,7	0,4	23,72	238
16 IL 0,5	0,50	16	0,6	0,6	23,72	240
16 IL 0,7	0,70	16	0,6	0,6	23,72	241
16 IL 0,75	0,75	16	0,6	0,6	23,72	242
16 IL 0,8	0,80	16	0,6	0,6	23,72	243
16 IL 1,0	1,00	16	0,6	0,7		
16 IL 1,0	1,00	16	0,7	0,7	22,17	244
16 IL 1,25	1,25	16	0,8	0,9	22,17	246
16 IL 1,5	1,50	16	0,8	1,0	22,17	248
16 IL 1,75	1,75	16	0,9	1,2	22,17	250
16 IL 2,0	2,00	16	1,0	1,3	22,17	252
16 IL 2,5	2,50	16	1,1	1,5	22,17	254
16 IL 3,0	3,00	16	1,2	1,6	22,17	256
22 IL 3,5	3,50	22	1,6	2,3	41,63	270
22 IL 4,0	4,00	22	1,6	2,3	41,63	272
22 IL 4,5	4,50	22	1,7	2,4	41,63	274
22 IL 5,0	5,00	22	1,7	2,5	41,63	276
22 IL 5,5	5,50	22	1,9	2,7	41,63	278
22 IL 6,0	6,00	22	2,0	2,9	41,63	280
P					●	●
M					●	○
K					●	●
N						●
S					○	
H					○	
O						○

8

Right hand external thread turning insert

▲ Multi edge insert

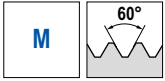

HCN2525

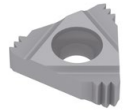
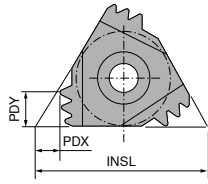

ER
71 221 ...
EUR
X3
46,46 700
44,63 702

Designation	TP mm	INSL mm	PDX mm	PDY mm	NT
16 ER 1,0 3M	1,0	16	1,7	2,5	3
16 ER 1,5 2M	1,5	16	1,5	2,3	2

P	○
M	●
K	○
N	○
S	○
H	○
O	○

→ v_c Page 45

Right hand external thread turning insert

▲ Full profile

▲ CCN7525 grade with sintered chip breaker for universal application

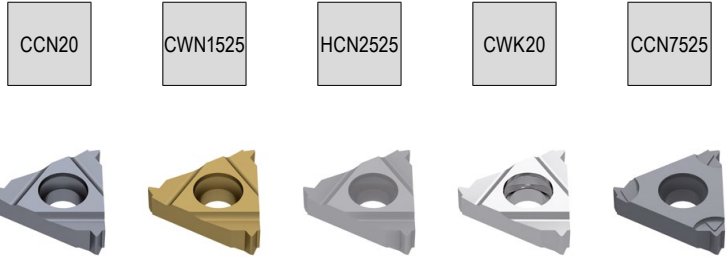
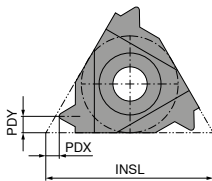

Designation	TPI	INSL mm	PDX mm	PDY mm	ER 71 228 ...		ER 71 228 ...		ER 71 228 ...		ER 71 228 ...		ER 71 228 ...	
					EUR X3		EUR X3		EUR X3		EUR Y1		EUR X3	
11 ER 72	72,0	11	0,7	0,4	27,97	202								
11 ER 60	60,0	11	0,7	0,4	27,97	204								
11 ER 56	56,0	11	0,7	0,4	27,97	206								
11 ER 48	48,0	11	0,6	0,6	27,97	208								
11 ER 40	40,0	11	0,6	0,6	27,97	210								
11 ER 36	36,0	11	0,6	0,6	27,97	212								
11 ER 32	32,0	11	0,6	0,6	27,97	214								
11 ER 28	28,0	11	0,6	0,7	25,71	216								
11 ER 26	26,0	11	0,7	0,8	25,71	218								
11 ER 24	24,0	11	0,7	0,8	25,71	220								
11 ER 22	22,0	11	0,8	0,9	25,71	222								
11 ER 20	20,0	11	0,8	0,9	25,71	224								
11 ER 19	19,0	11	0,8	1,0	25,71	226								
11 ER 18	18,0	11	0,8	1,0	25,71	228								
11 ER 16	16,0	11	0,9	1,1	25,71	230								
11 ER 14	14,0	11	0,9	1,1	25,71	232								
16 ER 40	40,0	16	0,6	0,6	27,97	240					18,19	640		
16 ER 36	36,0	16	0,6	0,6	27,97	242					18,19	642		
16 ER 32	32,0	16	0,6	0,6	27,97	244					18,19	644		
16 ER 28	28,0	16	0,6	0,7	25,71	246	24,71	146	26,99	746	16,76	646		
16 ER 26	26,0	16	0,7	0,7					30,11	748				
16 ER 26	26,0	16	0,7	0,8	25,71	248					16,76	648		
16 ER 24	24,0	16	0,7	0,8	25,71	250					16,76	650		
16 ER 22	22,0	16	0,8	0,9	25,71	252					16,76	652		
16 ER 20	20,0	16	0,8	0,9	25,71	254			30,11	754	16,76	654		
16 ER 19	19,0	16	0,8	1,0	25,71	256	22,17	156	24,44	756	16,76	656	24,44	956
16 ER 18	18,0	16	0,8	1,0	25,71	258					16,76	658		
16 ER 16	16,0	16	0,9	1,1	25,71	260	27,42	160	29,40	760	16,76	660		
16 ER 14	14,0	16	1,0	1,2	25,71	262	22,17	162	24,44	762	16,76	662	24,44	962
16 ER 12	12,0	16	1,1	1,4	25,71	264	27,42	164	29,40	764	16,76	664		
16 ER 11	11,0	16	1,1	1,5	25,71	266	22,17	166	24,44	766	16,76	666	24,44	966
16 ER 10	10,0	16	1,1	1,5	25,71	268					16,76	668		
16 ER 9	9,0	16	1,2	1,7	25,71	270					16,76	670		
16 ER 8	8,0	16	1,2	1,5	25,71	272					16,76	672		
22 ER 7	7,0	22	1,6	2,3	39,76	280								
22 ER 6	6,0	22	1,6	2,3	39,76	282								
22 ER 5	5,0	22	1,7	2,4	39,76	284								
22 EN 4,5	4,5	22	2,3	11,0	42,76	290								
22 EN 4	4,0	22	1,8	11,0	42,76	292								
P					●		●		○				●	
M					●		○		●		○		●	
K					●		●		○		●		●	
N							●		○		●			
S					○				○		○		●	
H					○				○				○	
O							○							

1) Neutral version (N) – for right and left hand thread applications. Neutral Toolholder marked (U) is required.

Left hand external thread turning insert

▲ Full profile

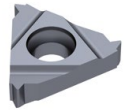
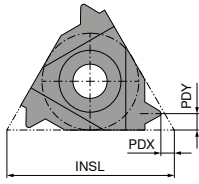

EL

71 229 ...

Designation	TPI 1/"	INSL mm	PDX mm	PDY mm	EL	
					EUR X3	
11 EL 72	72	11	0,7	0,4	32,11	202
11 EL 60	60	11	0,7	0,4	32,11	204
11 EL 56	56	11	0,7	0,4	32,11	206
11 EL 48	48	11	0,6	0,6	32,11	208
11 EL 40	40	11	0,6	0,6	32,11	210
11 EL 36	36	11	0,6	0,6	32,11	212
11 EL 32	32	11	0,6	0,6	32,11	214
11 EL 28	28	11	0,6	0,7	30,11	216
11 EL 26	26	11	0,7	0,8	30,11	218
11 EL 24	24	11	0,7	0,8	30,11	220
11 EL 22	22	11	0,8	0,9	30,11	222
11 EL 20	20	11	0,8	0,9	30,11	224
11 EL 19	19	11	0,8	1,0	30,11	226
11 EL 18	18	11	0,8	1,0	30,11	228
11 EL 16	16	11	0,9	1,1	30,11	230
11 EL 14	14	11	0,9	1,1	25,71	232
16 EL 40	40	16	0,6	0,6	32,11	240
16 EL 36	36	16	0,6	0,6	32,11	242
16 EL 32	32	16	0,6	0,6	32,11	244
16 EL 28	28	16	0,6	0,7	30,11	246
16 EL 26	26	16	0,7	0,8	30,11	248
16 EL 24	24	16	0,7	0,8	30,11	250
16 EL 22	22	16	0,8	0,9	30,11	252
16 EL 20	20	16	0,8	0,9	30,11	254
16 EL 19	19	16	0,8	1,0	30,11	256
16 EL 18	18	16	0,8	1,0	30,11	258
16 EL 16	16	16	0,9	1,1	30,11	260
16 EL 14	14	16	1,0	1,2	25,71	262
16 EL 12	12	16	1,1	1,4	30,11	264
16 EL 11	11	16	1,1	1,5	25,71	266
16 EL 10	10	16	1,1	1,5	34,38	268
16 EL 9	9	16	1,2	1,7	34,38	270
16 EL 8	8	16	1,2	1,5	34,38	272
22 EL 7	7	22	1,6	2,3	46,59	280
22 EL 6	6	22	1,6	2,3	46,59	282
22 EL 5	5	22	1,7	2,4	47,60	284

P	●
M	●
K	●
N	
S	○
H	○
O	

→ v. Page 45

Right hand internal thread turning insert

▲ Full profile

▲ CCN7525 grade with sintered chip breaker for universal application

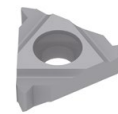
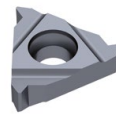
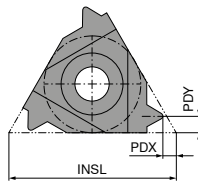

Designation	TPI	INSL mm	PDX mm	PDY mm	IR 71 230 ...		IR 71 230 ...		IR 71 230 ...		IR 71 230 ...	
					EUR X3		EUR X3		EUR X3		EUR X3	
11 IR 48	48	11	0,6	0,6	27,97	206						
11 IR 40	40	11	0,6	0,6	27,97	208						
11 IR 36	36	11	0,6	0,6	27,97	210						
11 IR 32	32	11	0,6	0,6	27,97	212						
11 IR 28	28	11	0,6	0,7	25,71	214						
11 IR 26	26	11	0,7	0,8	25,71	216						
11 IR 24	24	11	0,7	0,8	25,71	218						
11 IR 22	22	11	0,8	0,9	25,71	220						
11 IR 20	20	11	0,8	0,9	25,71	222						
11 IR 19	19	11	0,8	1,0	25,71	224						
11 IR 19	19	11	0,8	0,9			23,60	124	25,86	724		
11 IR 18	18	11	0,8	1,0	25,71	226						25,86 924
11 IR 16	16	11	0,9	1,1	25,71	228						
11 IR 14	14	11	0,9	1,1	25,71	230						
11 IR 14	14	11	0,8	0,9			23,60	130	25,86	730		25,86 930
16 IR 40	40	16	0,6	0,6	27,97	240						
16 IR 36	36	16	0,6	0,6	27,97	242						
16 IR 32	32	16	0,6	0,6	27,97	244						
16 IR 28	28	16	0,6	0,7	25,71	246						
16 IR 26	26	16	0,7	0,8	25,71	248						
16 IR 24	24	16	0,7	0,8	25,71	250						
16 IR 22	22	16	0,8	0,9	25,71	252						
16 IR 20	20	16	0,8	0,9	25,71	254						
16 IR 19	19	16	0,8	1,0	25,71	256						
16 IR 18	18	16	0,8	1,0	25,71	258						
16 IR 16	16	16	0,9	1,1	25,71	260						
16 IR 14	14	16	1,0	1,2	25,71	262			30,11	760		
16 IR 12	12	16	1,1	1,4	25,71	264			22,17	162	24,44	962
16 IR 11	11	16	1,1	1,5	25,71	266			22,17	166	24,44	966
16 IR 10	10	16	1,1	1,5	25,71	268						
16 IR 9	9	16	1,2	1,7	25,71	270						
16 IR 8	8	16	1,2	1,5	25,71	272						
22 IR 7	7	22	1,6	2,3	40,22	280						
22 IR 6	6	22	1,6	2,3	40,22	282						
22 IR 5	5	22	1,7	2,4	40,22	284						
P					●	●	○	●				
M					●	○	●	●				
K					●	●	○	○				
N						●	○	○				
S					○	○	○	○				
H					○			○				
O							○					

8

→ v. Page 45

Left hand internal thread turning insert

▲ Full profile

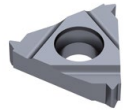
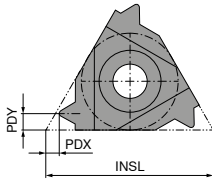

IL
71 231 ...

Designation	TPI 1/"	INSL mm	PDX mm	PDY mm	EUR	
					X3	
11 IL 48	48	11	0,6	0,6	32,11	206
11 IL 40	40	11	0,6	0,6	32,11	208
11 IL 36	36	11	0,6	0,6	30,11	210
11 IL 32	32	11	0,6	0,6	30,11	212
11 IL 28	28	11	0,6	0,7	30,11	214
11 IL 26	26	11	0,7	0,8	30,11	216
11 IL 24	24	11	0,7	0,8	30,11	218
11 IL 22	22	11	0,8	0,9	30,11	220
11 IL 20	20	11	0,8	0,9	30,11	222
11 IL 19	19	11	0,8	1,0	30,11	224
11 IL 18	18	11	0,8	1,0	30,11	226
11 IL 16	16	11	0,9	1,1	30,11	228
11 IL 14	14	11	0,9	1,1	25,71	230
16 IL 40	40	16	0,6	0,6	32,11	240
16 IL 36	36	16	0,6	0,6	32,11	242
16 IL 32	32	16	0,6	0,6	32,11	244
16 IL 28	28	16	0,6	0,7	30,11	246
16 IL 26	26	16	0,7	0,8	30,11	248
16 IL 24	24	16	0,7	0,8	30,11	250
16 IL 22	22	16	0,8	0,9	30,11	252
16 IL 20	20	16	0,8	0,9	30,11	254
16 IL 19	19	16	0,8	1,0	30,11	256
16 IL 18	18	16	0,8	1,0	30,11	258
16 IL 16	16	16	0,9	1,1	30,11	260
16 IL 14	14	16	1,0	1,2	25,71	262
16 IL 12	12	16	1,1	1,4	30,11	264
16 IL 11	11	16	1,1	1,5	25,71	266
16 IL 10	10	16	1,1	1,5	34,38	268
16 IL 9	9	16	1,2	1,7	34,38	270
16 IL 8	8	16	1,2	1,5	34,38	272
22 IL 7	7	22	1,6	2,3	46,59	280
22 IL 6	6	22	1,6	2,3	46,59	282
22 IL 5	5	22	1,7	2,4	46,59	284

P	●
M	●
K	●
N	
S	○
H	○
O	

→ v. Page 45

Right hand external thread turning insert

▲ Full profile

▲ CCN7525 grade with sintered chip breaker for universal application

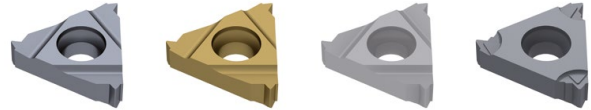
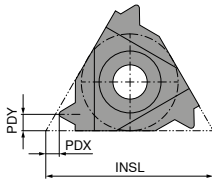

Designation	TPI 1/"	INSL mm	PDX mm	PDY mm	ER 71 264 ...		ER 71 264 ...		ER 71 264 ...		ER 71 264 ...	
					EUR X3		EUR X3		EUR X3		EUR X3	
11 ER 72	72,0	11	0,8	0,4	28,13	202						
11 ER 64	64,0	11	0,8	0,4	28,13	204						
11 ER 56	56,0	11	0,7	0,4	28,13	206						
11 ER 48	48,0	11	0,6	0,6	28,13	208						
11 ER 44	44,0	11	0,6	0,6	28,13	210						
11 ER 40	40,0	11	0,6	0,6	28,13	212						
11 ER 36	36,0	11	0,6	0,6	28,13	214						
11 ER 32	32,0	11	0,6	0,6	28,13	216						
11 ER 28	28,0	11	0,6	0,7	25,71	218						
11 ER 27	27,0	11	0,7	0,8	25,71	220						
11 ER 24	24,0	11	0,7	0,8	25,71	222						
11 ER 20	20,0	11	0,8	0,9	25,71	224						
11 ER 18	18,0	11	0,8	1,0	25,71	226						
11 ER 16	16,0	11	0,9	1,1	25,71	228						
11 ER 14	14,0	11	0,9	1,1	25,71	230						
16 ER 72	72,0	16	0,8	0,4	27,97	232						
16 ER 64	64,0	16	0,8	0,4	27,97	234						
16 ER 56	56,0	16	0,7	0,4	27,97	236						
16 ER 48	48,0	16	0,6	0,6	27,97	238						
16 ER 44	44,0	16	0,6	0,6	27,97	240						
16 ER 40	40,0	16	0,6	0,6	27,97	242						
16 ER 36	36,0	16	0,6	0,6	27,97	244						
16 ER 32	32,0	16	0,6	0,6	27,97	246			31,68	746		
16 ER 28	28,0	16	0,6	0,7	25,71	248			29,40	748		
16 ER 27	27,0	16	0,7	0,8	25,71	250						
16 ER 24	24,0	16	0,7	0,8	25,71	252	24,71	152	26,99	752		
16 ER 20	20,0	16	0,8	0,9	25,71	254	23,60	154	25,86	754	25,86	954
16 ER 18	18,0	16	0,8	1,0	25,71	256	24,71	156	26,99	756		
16 ER 16	16,0	16	0,9	1,1	25,71	258	23,60	158	25,86	758	25,86	958
16 ER 14	14,0	16	1,0	1,2	25,71	260	24,71	160	26,99	760		
16 ER 13	13,0	16	1,0	1,3	25,71	262						
16 ER 12	12,0	16	1,1	1,4	25,71	264	24,71	164	26,99	764		
16 ER 11,5	11,5	16	1,1	1,5	25,71	266						
16 ER 11	11,0	16	1,1	1,5	25,71	268	28,13	168				
16 ER 10	10,0	16	1,1	1,5	25,71	270						
16 ER 9	9,0	16	1,2	1,7	25,71	272						
16 ER 8	8,0	16	1,2	1,6	25,71	274						
16 ER 8	8,0	16	1,1	1,1							30,11	974
16 ER 8	8,0	16	1,1	1,5			28,13	174				
22 ER 7	7,0	22	1,6	2,3	40,22	276						
22 ER 6	6,0	22	1,6	2,3	40,22	278						
22 ER 5	5,0	22	1,7	2,5	40,22	280						
22 EN 4,5	4,5	22	2,0	11,0	42,76	282 ¹⁾						
22 EN 4	4,0	22	2,0	11,0	42,76	284 ¹⁾						
P					●		●		○		●	
M					●		○		●		●	
K					●		●		○		●	
N							●		○			
S					○				○		●	
H					○				○		○	
O									○			

1) Neutral version (N) – for right and left hand thread applications. Neutral Toolholder marked (U) is required.

Left hand external thread turning insert

▲ Full profile



CCN20

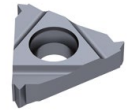
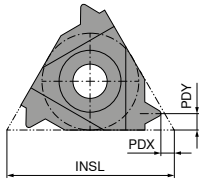

EL
71 266 ...

Designation	TPI 1/"	INSL mm	PDX mm	PDY mm	EUR	
					X3	
11 EL 72	72,0	11	0,8	0,4	32,94	202
11 EL 64	64,0	11	0,8	0,4	32,94	204
11 EL 56	56,0	11	0,7	0,4	32,94	206
11 EL 48	48,0	11	0,6	0,6	32,94	208
11 EL 44	44,0	11	0,6	0,6	32,94	210
11 EL 40	40,0	11	0,6	0,6	32,94	212
11 EL 36	36,0	11	0,6	0,6	32,94	214
11 EL 32	32,0	11	0,6	0,6	32,94	216
11 EL 28	28,0	11	0,6	0,7	32,94	218
11 EL 27	27,0	11	0,7	0,8	32,94	220
11 EL 24	24,0	11	0,7	0,8	32,94	222
11 EL 20	20,0	11	0,8	0,9	32,94	224
11 EL 18	18,0	11	0,8	1,0	32,94	226
11 EL 16	16,0	11	0,9	1,1	32,94	228
11 EL 14	14,0	11	0,9	1,1	32,94	230
16 EL 72	72,0	16	0,8	0,4	32,11	232
16 EL 64	64,0	16	0,8	0,4	32,11	234
16 EL 56	56,0	16	0,7	0,4	32,11	236
16 EL 48	48,0	16	0,6	0,6	32,11	238
16 EL 44	44,0	16	0,6	0,6	32,11	240
16 EL 40	40,0	16	0,6	0,6	32,11	242
16 EL 36	36,0	16	0,6	0,6	32,11	244
16 EL 32	32,0	16	0,6	0,6	32,11	246
16 EL 28	28,0	16	0,6	0,7	30,11	248
16 EL 27	27,0	16	0,7	0,8	30,11	250
16 EL 24	24,0	16	0,7	0,8	30,11	252
16 EL 20	20,0	16	0,8	0,9	30,11	254
16 EL 18	18,0	16	0,8	1,0	30,11	256
16 EL 16	16,0	16	0,9	1,1	30,11	258
16 EL 14	14,0	16	1,0	1,2	30,11	260
16 EL 13	13,0	16	1,0	1,3	30,11	262
16 EL 12	12,0	16	1,1	1,4	25,71	264
16 EL 11,5	11,5	16	1,1	1,5	34,38	266
16 EL 11	11,0	16	1,1	1,5	34,38	268
16 EL 10	10,0	16	1,1	1,5	34,38	270
16 EL 9	9,0	16	1,2	1,7	34,38	272
16 EL 8	8,0	16	1,2	1,6	34,38	274
22 EL 7	7,0	22	1,6	2,3	46,59	276
22 EL 6	6,0	22	1,6	2,3	46,59	278
22 EL 5	5,0	22	1,7	2,5	46,59	280

P	●
M	●
K	●
N	
S	○
H	○
O	

→ v_c Page 45

Right hand internal thread turning insert

▲ Full profile

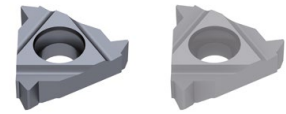
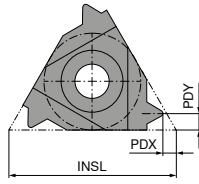

Designation	TPI 1/"	INSL mm	PDX mm	PDY mm	IR	
					71 268 ... EUR X3	71 268 ... EUR X3
11 IR 72	72,0	11	0,8	0,3	28,13	202
11 IR 64	64,0	11	0,8	0,4	28,13	204
11 IR 56	56,0	11	0,7	0,4	28,13	206
11 IR 48	48,0	11	0,6	0,6	28,13	208
11 IR 44	44,0	11	0,6	0,6	28,13	210
11 IR 40	40,0	11	0,6	0,6	28,13	212
11 IR 36	36,0	11	0,6	0,6	28,13	214
11 IR 32	32,0	11	0,6	0,6	28,13	216
11 IR 28	28,0	11	0,6	0,7	25,71	218
11 IR 27	27,0	11	0,7	0,8	25,71	220
11 IR 24	24,0	11	0,7	0,8	25,71	222
11 IR 20	20,0	11	0,8	0,9	25,71	224
11 IR 18	18,0	11	0,8	1,0	25,71	226
11 IR 16	16,0	11	0,9	1,1	25,71	228
11 IR 14	14,0	11	1,0	1,1	25,71	230
16 IR 72	72,0	16	0,8	0,3	27,97	232
16 IR 64	64,0	16	0,8	0,4	27,97	234
16 IR 56	56,0	16	0,7	0,4	27,97	236
16 IR 48	48,0	16	0,6	0,6	27,97	238
16 IR 44	44,0	16	0,6	0,6	27,97	240
16 IR 40	40,0	16	0,6	0,6	27,97	242
16 IR 36	36,0	16	0,6	0,6	27,97	244
16 IR 32	32,0	16	0,6	0,6	27,97	246
16 IR 28	28,0	16	0,6	0,7	25,71	248
16 IR 27	27,0	16	0,7	0,8	25,71	250
16 IR 24	24,0	16	0,7	0,8	25,71	252
16 IR 20	20,0	16	0,8	0,9	25,71	254
16 IR 18	18,0	16	0,8	1,0	25,71	256
16 IR 16	16,0	16	0,9	1,1	25,71	258
16 IR 14	14,0	16	1,0	1,2	25,71	260
16 IR 13	13,0	16	1,0	1,3	25,71	262
16 IR 12	12,0	16	1,1	1,4	25,71	264
16 IR 11,5	11,5	16	1,1	1,5	25,71	266
16 IR 11	11,0	16	1,1	1,5	25,71	268
16 IR 10	10,0	16	1,1	1,5	25,71	270
16 IR 9	9,0	16	1,2	1,7	25,71	272
16 IR 8	8,0	16	1,2	1,6	25,71	274
16 IR 8	8,0	16	1,1	1,5		30,11 774
22 IR 7	7,0	22	1,6	2,3	40,22	276
22 IR 6	6,0	22	1,6	2,3	40,22	278
22 IR 5	5,0	22	1,7	2,5	40,22	280
22 IN 4,5	4,5	22	2,0	11,0	42,76	282 ¹⁾
22 IN 4	4,0	22	2,0	11,0	42,76	284 ¹⁾
P					●	○
M					●	●
K					●	○
N						○
S					○	○
H					○	○
O						

1) Neutral version (N) – for right and left hand thread applications. Neutral Toolholder marked (U) is required.

Left hand internal thread turning insert

▲ Full profile



CCN20

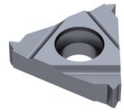
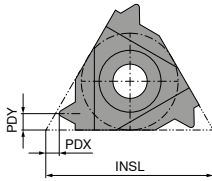

IL
71 270 ...

Designation	TPI 1/"	INSL mm	PDX mm	PDY mm	EUR	
					Price	Code
11 IL 72	72,0	11	0,8	0,3	32,94	202
11 IL 64	64,0	11	0,8	0,4	32,94	204
11 IL 56	56,0	11	0,7	0,4	32,94	206
11 IL 48	48,0	11	0,6	0,6	32,94	208
11 IL 44	44,0	11	0,6	0,6	32,94	210
11 IL 40	40,0	11	0,6	0,6	32,94	212
11 IL 36	36,0	11	0,6	0,6	32,94	214
11 IL 32	32,0	11	0,6	0,6	32,94	216
11 IL 28	28,0	11	0,6	0,7	32,94	218
11 IL 27	27,0	11	0,7	0,8	32,94	220
11 IL 24	24,0	11	0,7	0,8	32,94	222
11 IL 20	20,0	11	0,8	0,9	32,94	224
11 IL 18	18,0	11	0,8	1,0	32,94	226
11 IL 16	16,0	11	0,9	1,1	32,94	228
11 IL 14	14,0	11	0,9	1,1	32,94	230
16 IL 72	72,0	16	0,8	0,3	32,94	232
16 IL 64	64,0	16	0,8	0,4	32,94	234
16 IL 56	56,0	16	0,7	0,4	32,94	236
16 IL 48	48,0	16	0,6	0,6	32,94	238
16 IL 44	44,0	16	0,6	0,6	32,94	240
16 IL 40	40,0	16	0,6	0,6	32,94	242
16 IL 36	36,0	16	0,6	0,6	32,94	244
16 IL 32	32,0	16	0,6	0,6	32,94	246
16 IL 28	28,0	16	0,6	0,7	32,94	248
16 IL 27	27,0	16	0,7	0,8	32,94	250
16 IL 24	24,0	16	0,7	0,8	32,94	252
16 IL 20	20,0	16	0,8	0,9	32,94	254
16 IL 18	18,0	16	0,8	1,0	32,94	256
16 IL 16	16,0	16	0,9	1,1	32,94	258
16 IL 14	14,0	16	1,0	1,2	32,94	260
16 IL 13	13,0	16	1,0	1,3	32,94	262
16 IL 12	12,0	16	1,1	1,4	32,94	264
16 IL 11,5	11,5	16	1,1	1,5	32,94	266
16 IL 11	11,0	16	1,1	1,5	32,94	268
16 IL 10	10,0	16	1,1	1,5	32,94	270
16 IL 9	9,0	16	1,2	1,7	32,94	272
16 IL 8	8,0	16	1,2	1,6	32,94	274
22 IL 7	7,0	22	1,6	2,3	32,94	276
22 IL 6	6,0	22	1,6	2,3	32,94	278
22 IL 5	5,0	22	1,7	2,5	32,94	280

P	●
M	●
K	●
N	
S	○
H	○
O	

→ v_c Page 45

Right hand external thread turning insert

▲ Full profile

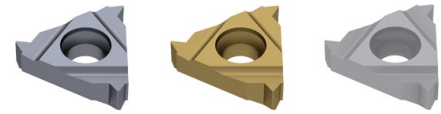
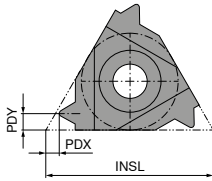
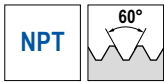

Designation	TPI 1/"	INSL mm	PDX mm	PDY mm
16 ER 27	27,0	16	0,7	0,8
16 ER 18	18,0	16	0,8	1,0
16 ER 14	14,0	16	0,9	1,2
16 ER 11,5	11,5	16	1,1	1,5
16 ER 8	8,0	16	1,3	1,8

ER 71 256 ...		ER 71 256 ...		ER 71 256 ...	
EUR		EUR		EUR	
X3		X3		X3	
28,84	240				
28,84	242			32,55	742
28,84	244	27,42	144	29,84	744
28,84	246	29,69	146	32,55	746
28,84	248				

P	●	●	○
M	●	○	●
K	●	●	○
N		●	○
S	○	○	○
H	○		○
O		○	

→ v_c Page 45

8

Left hand external thread turning insert

▲ Full profile

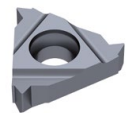
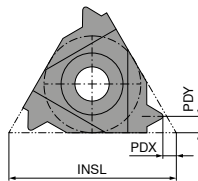
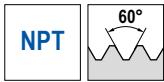

Designation	TPI 1/"	INSL mm	PDX mm	PDY mm
16 EL 27	27,0	16	0,7	0,8
16 EL 18	18,0	16	0,8	1,0
16 EL 14	14,0	16	0,9	1,2
16 EL 11,5	11,5	16	1,1	1,5
16 EL 8	8,0	16	1,3	1,8

EL 71 258 ...	
EUR	
X3	
33,54	240
33,54	242
33,54	244
33,54	246
33,54	248

P	●
M	●
K	●
N	
S	○
H	○
O	

→ v_c Page 45

Right hand internal thread turning insert

- ▲ Full profile
- ▲ CCN7525 grade with sintered chip breaker for universal application

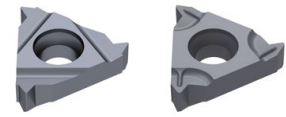
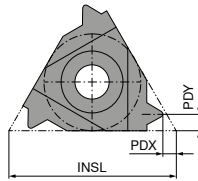
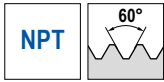

Designation	TPI 1/"	INSL mm	PDX mm	PDY mm
11 IR 27	27,0	11	0,7	0,8
11 IR 18	18,0	11	0,8	1,0
11 IR 14	14,0	11	0,9	1,1
16 IR 27	27,0	16	0,7	0,8
16 IR 18	18,0	16	0,8	1,0
16 IR 14	14,0	16	0,9	1,2
16 IR 11,5	11,5	16	1,1	1,5
16 IR 8	8,0	16	1,3	1,8

IR 71 260 ...		IR 71 260 ...	
EUR		EUR	
X3		X3	
28,84	210		
28,84	212		
28,84	214		
28,84	240		
28,84	242		
28,84	244	34,38	944
28,84	246	34,81	946
28,84	248		

P	●	●
M	●	●
K	●	●
N		
S	○	●
H	○	○
O		

→ v_c Page 45

Left hand internal thread turning insert

- ▲ Full profile

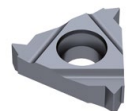
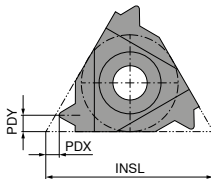

Designation	TPI 1/"	INSL mm	PDX mm	PDY mm
11 IL 27	27,0	11	0,7	0,8
11 IL 18	18,0	11	0,8	1,0
11 IL 14	14,0	11	0,9	1,1
16 IL 27	27,0	16	0,7	0,8
16 IL 18	18,0	16	0,8	1,0
16 IL 14	14,0	16	0,9	1,2
16 IL 11,5	11,5	16	1,1	1,5
16 IL 8	8,0	16	1,3	1,8

IL 71 262 ...	
EUR	
X3	
33,54	210
33,54	212
33,54	214
33,54	240
33,54	242
33,54	244
33,54	246
33,54	248

P	●
M	●
K	●
N	
S	○
H	○
O	

→ v_c Page 45

Right hand external thread turning insert

- ▲ Full profile
- ▲ Trapezoidal thread DIN 103

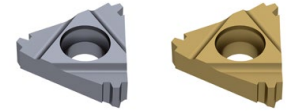
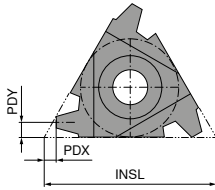
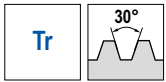

Designation	TP mm	INSL mm	PDX mm	PDY mm	ER		ER	
					71 232 ... EUR X3		71 232 ... EUR X3	
16 ER 1,5	1,5	16	1,0	1,1	31,12	240		
16 ER 2,0	2,0	16	1,1	1,3	31,12	242		
16 ER 2,0	2,0	16	1,0	1,3			29,27	142
16 ER 3,0	3,0	16	1,3	1,5	31,12	244	27,85	144
22 ER 4,0	4,0	22	1,8	1,9			39,76	170
22 ER 4,0	4,0	22	1,7	1,9	42,91	270		
22 ER 5,0	5,0	22	2,0	2,4			43,76	172
22 ER 5,0	5,0	22	2,1	2,5	44,74	272		
22 ER 6,0	6,0	22	2,3	2,7	46,59	274 ¹⁾		
22 EN 6,0	6,0	22	2,0	11,0	46,59	276 ²⁾		
22 EN 7,0	7,0	22	2,3	11,0	48,45	278 ²⁾		

P	●	●
M	●	○
K	●	●
N		●
S	○	
H	○	
O		○

- Requires special holder or an independently modified standard holder
- Neutral version (N) – for right and left hand thread applications. Neutral Toolholder marked (U) is required.

→ v_c Page 45

Left hand external thread turning insert

- ▲ Full profile
- ▲ Trapezoidal thread DIN 103

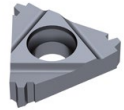
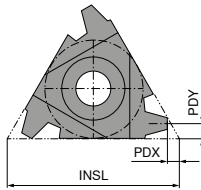
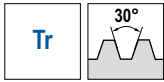

Designation	TP mm	INSL mm	PDX mm	PDY mm
16 EL 1,5	1,5	16	1,0	1,1
16 EL 2,0	2,0	16	1,1	1,3
16 EL 3,0	3,0	16	1,3	1,5
22 EL 4,0	4,0	22	1,7	1,9
22 EL 5,0	5,0	22	2,1	2,5
22 EL 6,0	6,0	22	2,3	2,7

EL	
71 234 ...	
EUR	
X3	
36,09	240
36,09	242
36,09	244
50,28	270
52,56	272
54,69	274 ¹⁾

P	●
M	●
K	●
N	●
S	○
H	○
O	○

1) Requires special holder or an independently modified standard holder

→ v_c Page 45

Right hand internal thread turning insert

- ▲ Full profile
- ▲ Trapezoidal thread DIN 103

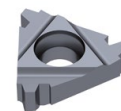
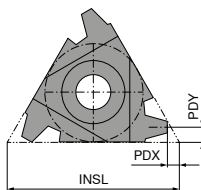

Designation	TP mm	INSL mm	PDX mm	PDY mm
11 IR 1,5	1,5	11	0,815	0,9
16 IR 1,5	1,5	16	1,000	1,1
16 IR 2,0	2,0	16	1,100	1,3
16 IR 3,0	3,0	16	1,300	1,5
22 IR 4,0	4,0	22	1,800	1,9
22 IR 4,0	4,0	22	1,700	1,9
22 IR 5,0	5,0	22	2,000	2,4
22 IR 5,0	5,0	22	2,100	2,5
22 IR 6,0	6,0	22	2,300	2,7
22 IN 6,0	6,0	22	2,000	11,0
22 IN 7,0	7,0	22	2,300	11,0

IR		IR	
71 236 ...		71 236 ...	
EUR		EUR	
X3		X3	
30,82	210		
30,82	240		
30,82	242	31,84	144
30,82	244		
42,91	270	41,91	170
44,74	272	43,46	172
46,59	274 ¹⁾		
46,59	276 ²⁾		
48,45	278 ²⁾		

P	●	●
M	●	○
K	●	○
N	●	●
S	○	○
H	○	○
O	○	○

1) Requires special holder or an independently modified standard holder

→ v_c Page 45

2) Neutral version (N) – for right and left hand thread applications. Neutral Toolholder marked (U) is required.

Left hand internal thread turning insert

▲ Full profile

▲ Trapezoidal thread DIN 103

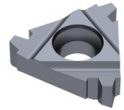
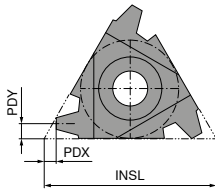

Designation	TP mm	INSL mm	PDX mm	PDY mm	IL	
					71 238 ...	EUR
11 IL 1,5	1,5	11	0,8	0,9	X3	210
16 IL 1,5	1,5	16	1,0	1,1	36,09	240
16 IL 2,0	2,0	16	1,1	1,3	36,09	242
16 IL 3,0	3,0	16	1,3	1,5	36,09	244
22 IL 4,0	4,0	22	1,7	1,9	50,28	270
22 IL 5,0	5,0	22	2,1	2,5	50,28	272
22 IL 6,0	6,0	22	2,3	2,7	52,56	274 ¹⁾
P						●
M						●
K						●
N						○
S						○
H						○
O						○

1) Requires special holder or an independently modified standard holder

Right hand external thread turning insert

- ▲ Full profile
- ▲ Round thread DIN 405

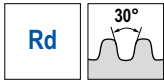

CCN20

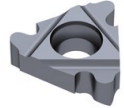
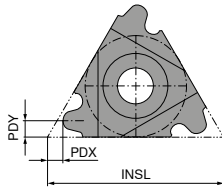

Designation	TPI	INSL	PDX	PDY	ER	
					71 248 ...	
16 ER 10	10	16	1,1	1,2	EUR X3	240
16 ER 8	8	16	1,4	1,3	30,82	242
16 ER 6	6	16	1,5	1,7	30,82	246
22 ER 6	6	22	1,5	1,7	43,05	270
22 ER 4	4	22	2,2	2,3	46,59	272

P	●
M	●
K	●
N	
S	○
H	○
O	

→ v_c Page 45

Left hand external thread turning insert

- ▲ Full profile
- ▲ Round thread DIN 405

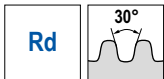

CCN20

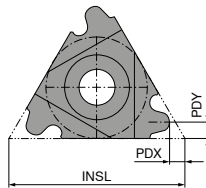

Designation	TPI	INSL	PDX	PDY	EL	
					71 250 ...	
16 EL 10	10	16	1,1	1,2	EUR X3	240
16 EL 8	8	16	1,4	1,3	35,96	242
16 EL 6	6	16	1,5	1,7	35,96	246
22 EL 6	6	22	1,5	1,7	50,43	270
22 EL 4	4	22	2,2	2,3	54,69	272

P	●
M	●
K	●
N	
S	○
H	○
O	

→ v_c Page 45

Right hand internal thread turning insert

- ▲ Full profile
- ▲ Round thread DIN 405

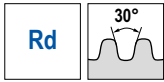

CCN20

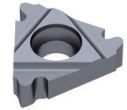
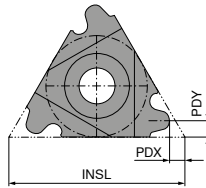

Designation	TPI	INSL	PDX	PDY	IR	
					71 252 ...	
					EUR	
					X3	
16 IR 10	10	16	1,1	1,2	30,82	240
16 IR 8	8	16	1,4	1,4	30,82	242
16 IR 6	6	16	1,4	1,5	30,82	246
22 IR 6	6	22	1,5	1,7	43,05	270
22 IR 4	4	22	2,2	2,3	46,59	272

P	●
M	●
K	●
N	○
S	○
H	○
O	○

→ v_c Page 45

Left hand internal thread turning insert

- ▲ Full profile
- ▲ Round thread DIN 405



CCN20

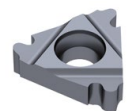
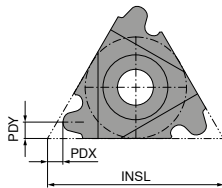

Designation	TPI	INSL	PDX	PDY	IL	
					71 254 ...	
					EUR	
					X3	
16 IL 10	10	16	1,1	1,2	28,84	240
16 IL 8	8	16	1,4	1,4	28,84	242
16 IL 6	6	16	1,4	1,5	28,84	246
22 IL 6	6	22	1,5	1,7	40,48	270
22 IL 4	4	22	2,2	2,3	43,63	272

P	●
M	●
K	●
N	○
S	○
H	○
O	○

→ v_c Page 45

Right hand external thread turning insert

- ▲ Full profile
- ▲ Conduit thread DIN 40430

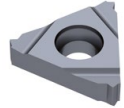
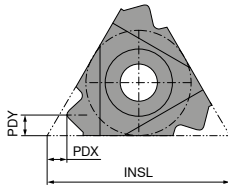
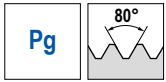

Designation	TPI	INSL	PDX	PDY	ER	
					71 240 ...	
16 ER 20	20	16	0,8	0,8	EUR X3	240
16 ER 18	18	16	0,8	0,9	30,82	242
16 ER 16	16	16	0,8	1,0	30,82	244
P						●
M						●
K						●
N						
S						○
H						○
O						

→ v_c Page 45

Left hand external thread turning insert

- ▲ Full profile
- ▲ Conduit thread DIN 40430

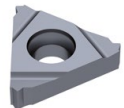
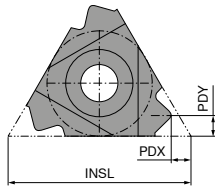
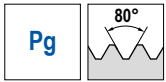

Designation	TPI	INSL	PDX	PDY	EL	
					71 242 ...	
16 EL 20	20	16	0,8	0,8	EUR X3	240
16 EL 18	18	16	0,8	0,9	33,96	242
16 EL 16	16	16	0,8	1,0	33,96	244
P						●
M						●
K						●
N						
S						○
H						○
O						

→ v_c Page 45

Right hand internal thread turning insert

- ▲ Full profile
- ▲ Conduit thread DIN 40430

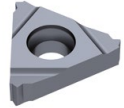
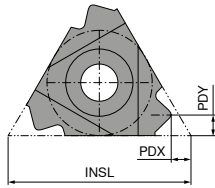
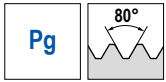

Designation	TPI	INSL mm	PDX mm	PDY mm	IR	
					71 244 ...	
11 IR 18	18	11	0,8	0,9	EUR X3 30,82	238
16 IR 18	18	16	0,8	0,9	30,82	242
16 IR 16	16	16	0,8	1,0	30,82	244
P						●
M						●
K						●
N						
S						○
H						○
O						

→ v_c Page 45

8

Left hand internal thread turning insert

- ▲ Full profile
- ▲ Conduit thread DIN 40430

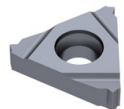
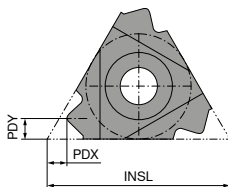

Designation	TPI	INSL mm	PDX mm	PDY mm	IL	
					71 246 ...	
11 IL 18	18	11	0,8	0,9	EUR X3 33,96	238
16 IL 18	18	16	0,8	0,9	33,96	242
16 IL 16	16	16	0,8	1,0	33,96	244
P						●
M						●
K						●
N						
S						○
H						○
O						

→ v_c Page 45

Right hand external thread turning insert

▲ Partial profile

▲ CCN7525 grade with sintered chip breaker for universal application

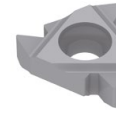
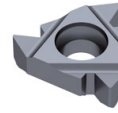
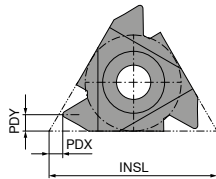

Designation	TP mm	INSL mm	PDX mm	PDY mm	ER 71 206 ...		ER 71 206 ...		ER 71 206 ...		ER 71 206 ...	
					EUR X3		EUR X3		EUR X3		EUR X3	
16 ER A60	0,5 - 1,5	16	0,8	0,9	23,88	240	21,32	140	23,60	740	23,60	940
16 ER AG60	0,5 - 3	16	1,2	1,7	24,59	244	20,45	144	22,58	744	22,58	944
16 ER G60	1,75 - 3	16	1,2	1,7	24,59	242	23,16	142	25,16	742	25,16	942
22 EN U60	5,5 - 8	22	0,9	11,0	38,35	272 ¹⁾						
22 ER N60	3,5 - 5	22	1,7	2,5	38,35	270	39,34	170				
P					●	●	○	○	○	○	○	○
M					●	●	○	○	○	○	○	○
K					●	●	○	○	○	○	○	○
N					○	○	●	●	○	○	○	○
S					○	○	○	○	○	○	○	○
H					○	○	○	○	○	○	○	○
O							○	○				

1) Neutral version (N) – for right and left hand thread applications. Neutral Toolholder marked (U) is required.

→ v_c Page 45

Left hand external thread turning insert

▲ Partial profile

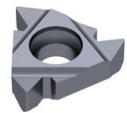
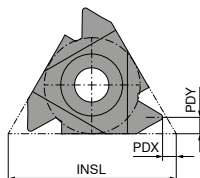

Designation	TP mm	INSL mm	PDX mm	PDY mm	EL 71 208 ...	
					EUR X3	
16 EL A60	0,5 - 1,5	16	0,8	0,9	26,16	240
16 EL AG60	0,5 - 3	16	1,2	1,7	27,57	244
16 EL G60	1,75 - 3	16	1,2	1,7	27,57	242
22 EL N60	3,5 - 5	22	1,7	2,5	44,74	270
P						●
M						●
K						●
N						○
S						○
H						○
O						○

→ v_c Page 45

Right hand internal thread turning insert

▲ Partial profile

▲ CCN7525 grade with sintered chip breaker for universal application

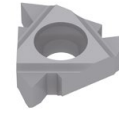
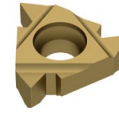
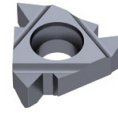
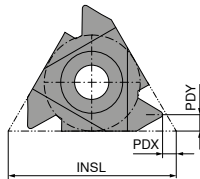

Designation	TP mm	INSL mm	PDX mm	PDY mm	IR 71 210 ...		IR 71 210 ...		IR 71 210 ...		IR 71 210 ...	
					EUR X3		EUR X3		EUR X3		EUR X3	
11 IR A60	0,5 - 1,5	11	0,8	0,9	23,88	210	21,75	110				
16 IR A60	0,5 - 1,5	16	0,8	0,9	23,88	240	26,30	140				
16 IR AG60	0,5 - 3	16	1,2	1,7	24,59	244	21,75	144	23,88	744	23,88	944
16 IR G60	1,75 - 3	16	1,2	1,7	24,59	242	23,16	142				
22 IN U60	5,5 - 8	22	0,9	11,0	38,35	272 ¹⁾						
22 IR N60	3,5 - 5	22	1,7	2,5	38,35	270	37,09	170				
P					●		●		○		●	
M					●		○		●		●	
K					●		●		○		●	
N							●		○			
S					○				○		○	
H					○				○		○	
O							○					

1) Neutral version (N) – for right and left hand thread applications. Neutral Toolholder marked (U) is required.

→ v_c Page 45

Left hand internal thread turning insert

▲ Partial profile

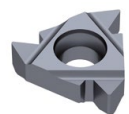
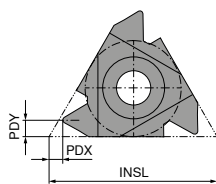

Designation	TP mm	INSL mm	PDX mm	PDY mm	IL 71 212 ...	
					EUR X3	
11 IL A60	0,5 - 1,5	11	0,8	0,9	26,16	210
16 IL A60	0,5 - 1,5	16	0,8	0,9	26,16	240
16 IL AG60	0,5 - 3	16	1,2	1,7	27,57	244
16 IL G60	1,75 - 3	16	1,2	1,7	27,57	242
22 IL N60	3,5 - 5	22	1,7	2,5	44,74	270
P						●
M						●
K						●
N						
S						○
H						○
O						

→ v_c Page 45

Right hand external thread turning insert

▲ Partial profile

▲ CCN7525 grade with sintered chip breaker for universal application

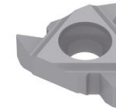
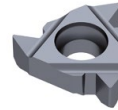
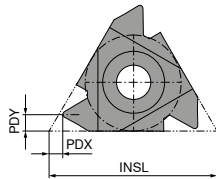

Designation	TPI 1/"	INSL mm	PDX mm	PDY mm	ER 71 200 ...		ER 71 200 ...		ER 71 200 ...		ER 71 200 ...	
					EUR X3		EUR X3		EUR X3		EUR X3	
16 ER A55	48 - 16	16	0,8	0,9	24,99	240	25,58	140	27,27	740	27,27	940
16 ER AG55	48 - 8	16	1,2	1,7	26,71	244	23,16	144	25,16	744	25,16	944
16 ER G55	14 - 8	16	1,2	1,7	26,71	242	25,58	142	27,69	742	27,69	942
22 ER N55	7 - 5	22	1,7	2,5	41,63	270	41,91	170	45,58	770		
22 EN U55	4,5 - 3,25	22	0,9	11,0	41,63	272 ¹⁾						

P	●	●	○	●
M	●	○	●	●
K	●	○	○	●
N		●	○	
S	○		○	●
H	○		○	○
O			○	

1) Neutral version (N) – for right and left hand thread applications. Neutral Toolholder marked (U) is required.

→ v_c Page 45

Left hand external thread turning insert

▲ Partial profile

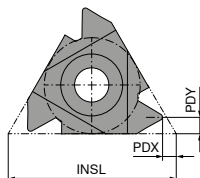

Designation	TPI 1/"	INSL mm	PDX mm	PDY mm	EL 71 202 ...	
					EUR X3	
16 EL A55	48 - 16	16	0,8	0,9	28,69	240
16 EL AG55	48 - 8	16	1,2	1,7	31,12	244
16 EL G55	14 - 8	16	1,2	1,7	31,12	242
22 EL N55	7 - 5	22	1,7	2,5	48,59	270

P	●
M	●
K	●
N	
S	○
H	○
O	

→ v_c Page 45

Right hand internal thread turning insert

▲ Partial profile

▲ CCN7525 grade with sintered chip breaker for universal application

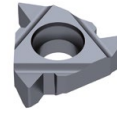
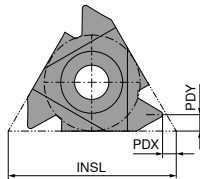

Designation	TPI 1/"	INSL mm	PDX mm	PDY mm	IR 71 204 ...		IR 71 204 ...		IR 71 204 ...	
					EUR X3		EUR X3		EUR X3	
11 IR A55	48 - 16	11	0,8	0,9	24,99	210				
16 IR A55	48 - 16	16	0,8	0,9	24,99	240				
16 IR AG55	48 - 8	16	1,2	1,7	26,71	244				
16 IR G55	14 - 8	16	1,2	1,7	26,71	242	25,58	142	27,69	942
22 IN U55	4,5 - 3,25	22	0,9	11,0	41,63	272 ¹⁾				
22 IR N55	7 - 5	22	1,7	2,5	41,63	270				
P						●		●		●
M						●		○		●
K						●		●		●
N								●		
S						○				●
H						○				○
O								○		

1) Neutral version (N) – for right and left hand thread applications. Neutral Toolholder marked (U) is required.

→ v. Page 45

Left hand internal thread turning insert

▲ Partial profile

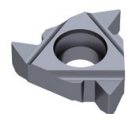
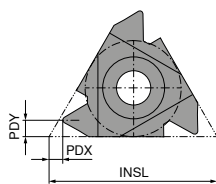

Designation	TPI 1/"	INSL mm	PDX mm	PDY mm	IL 71 203 ...	
					EUR X3	
11 IL A55	48 - 16	11	0,8	0,9	28,69	210
16 IL A55	48 - 16	16	0,8	0,9	28,69	240
16 IL AG55	48 - 8	16	1,2	1,7	31,12	244
16 IL G55	14 - 8	16	1,2	1,7	31,12	242
22 IL N55	7 - 5	22	1,7	2,5	48,59	270
P						●
M						●
K						●
N						
S						○
H						○
O						

→ v. Page 45

Standard External Thread Turning Holder

▲ Tool Holder with Approach Angle $\beta = 1,5^\circ$

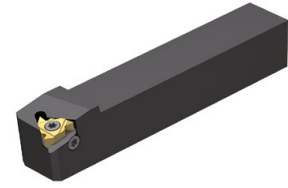
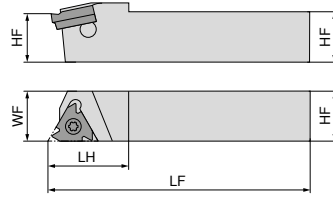

Illustrations show right-hand versions

ISO designation	HF mm	WF mm	LF mm	LH mm	Insert	torque moment Nm	Left-hand		Right-hand	
							71 281 ...	71 280 ...		
SE R/L 08 08 H11	8	11	100	16	11 ..	1,3	EUR Y2 86,11	908 ²⁾	EUR Y2 86,11	908 ²⁾
SE R/L 10 10 H11	10	12	100	18	11 ..	1,3	91,80	910 ²⁾	91,80	910 ²⁾
SE R/L 12 12 K11	12	12	125	20	11 ..	1,3	96,54	912 ²⁾	96,54	912 ²⁾
SE R/L 12 12 F16	12	16	80	22	16 ..	3,5	100,60	012	100,60	012
SE R/L 16 16 H16	16	16	100	25	16 ..	3,5	123,80	016	123,80	016
SE R/L 20 20 K16	20	20	125	30	16 ..	3,5	123,80	020	123,80	020
SE R/L 25 25 M16	25	25	150	30	16 ..	3,5	142,00	025	142,00	025
SE R/L 32 32 P16	32	32	170	30	16 ..	3,5	155,50	032	155,50	032
SE R/L 25 25 M22	25	25	150	32	22 ..	10	155,50	125	155,50	125
SE R 32 32 P22	32	32	170	34	22 ..	10			162,40	132
SE R 32 32 P22U	32	21	170	32	22 .N	10			162,40	232 ¹⁾

- 1) Neutral insert indicated by marking (N)
- 2) without shim



Spare parts for Article no.	71 950 ...		71 950 ...		71 950 ...		80 950 ...		71 950 ...				
	EUR Y2		EUR Y2		EUR Y2		EUR Y7		EUR Y2				
71 280 908 / 71 281 908							T08	10,05	110	1,41	230		
71 280 910 / 71 281 910							T08	10,05	110	1,41	230		
71 280 912 / 71 281 912							T08	10,05	110	1,41	230		
71 280 012	ER 16 / IL 16	16,39	101	ER 16 / IL 16	12,16	121	1,41	234	T10	11,78	112	1,41	231
71 281 012	EL 16 / IR 16	16,39	108	EL 16 / IR 16	11,07	129	1,41	234	T10	11,78	112	1,41	231
71 280 016	ER 16 / IL 16	16,39	101	ER 16 / IL 16	12,16	121	1,41	234	T10	11,78	112	1,41	231
71 281 016	EL 16 / IR 16	16,39	108	EL 16 / IR 16	11,07	129	1,41	234	T10	11,78	112	1,41	231
71 280 020	ER 16 / IL 16	16,39	101	ER 16 / IL 16	12,16	121	1,41	234	T10	11,78	112	1,41	231
71 281 020	EL 16 / IR 16	16,39	108	EL 16 / IR 16	11,07	129	1,41	234	T10	11,78	112	1,41	231
71 280 025	ER 16 / IL 16	16,39	101	ER 16 / IL 16	12,16	121	1,41	234	T10	11,78	112	1,41	231
71 281 025	EL 16 / IR 16	16,39	108	EL 16 / IR 16	11,07	129	1,41	234	T10	11,78	112	1,41	231
71 280 032	ER 16 / IL 16	16,39	101	ER 16 / IL 16	12,16	121	1,41	234	T10	11,78	112	1,41	231
71 281 032	EL 16 / IR 16	16,39	108	EL 16 / IR 16	11,07	129	1,41	234	T10	11,78	112	1,41	231
71 280 125				ER 22 / IL 22	17,63	137	2,13	235	T20	12,83	114	2,13	232
71 281 125				EL 22 / IR 22	17,63	145	2,13	235	T20	12,83	114	2,13	232
71 280 132				ER 22 / IL 22	17,63	137	2,13	235	T20	12,83	114	2,13	232
71 280 232				ER 22U / IL 22U	17,63	153	2,13	235	T20	12,83	114	2,13	232

Shims for correction of helix angle see page → Page 43.

External threading holder

▲ Tool Holder with Approach Angle $\beta = 1,5^\circ$

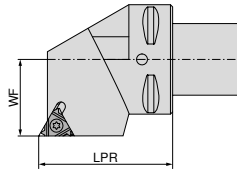

Illustrations show right-hand versions

ISO designation	Adapter	LPR mm	WF mm	Insert	torque moment Nm	Left-hand		Right-hand	
						84 191 ...	84 190 ...	84 191 ...	84 190 ...
PSC40 SE R/L 27050-16.IK	PSC 40	50	27	16 ..	3,5	EUR Y8 308,20	412	EUR Y8 308,20	412
PSC40 SE R/L 27050-22.IK	PSC 40	50	27	22 ..	10	308,20	422	308,20	422
PSC50 SE R/L 35060-16.IK	PSC 50	60	35	16 ..	3,5	340,70	512	340,70	512
PSC50 SE R/L 35060-22.IK	PSC 50	60	35	22 ..	10	340,70	522	340,70	522
PSC63 SE R/L 45065-16.IK	PSC 63	65	45	16 ..	3,5	390,70	612	390,70	612
PSC63 SE R/L 45065-22.IK	PSC 63	65	45	22 ..	10	390,70	622	390,70	622
PSC80 SE R/L 55080-22.IK	PSC 80	80	55	22 ..	10	412,30	822	412,30	822

Spare parts for Article no.	Multi tooth shim		Shim		Screw-U		Key D		Clamping screw	
	71 950 ...	71 950 ...	71 950 ...	71 950 ...	71 950 ...	71 950 ...	80 950 ...	80 950 ...	71 950 ...	71 950 ...
84 190 412	ER 16 / IL 16	16,39 101	ER 16 / IL 16	12,16 121	1,41 234	1,41 234	T10	11,78 112	1,41 231	1,41 231
84 191 412	EL 16 / IR 16	16,39 108	EL 16 / IR 16	11,07 129	1,41 234	1,41 234	T10	11,78 112	1,41 231	1,41 231
84 190 422			ER 22 / IL 22	17,63 137	2,13 235	2,13 235	T20	12,83 114	2,13 232	2,13 232
84 191 422			EL 22 / IR 22	17,63 145	2,13 235	2,13 235	T20	12,83 114	2,13 232	2,13 232
84 190 512	ER 16 / IL 16	16,39 101	ER 16 / IL 16	12,16 121	1,41 234	1,41 234	T10	11,78 112	1,41 231	1,41 231
84 191 512	EL 16 / IR 16	16,39 108	EL 16 / IR 16	11,07 129	1,41 234	1,41 234	T10	11,78 112	1,41 231	1,41 231
84 190 522			ER 22 / IL 22	17,63 137	2,13 235	2,13 235	T20	12,83 114	2,13 232	2,13 232
84 191 522			EL 22 / IR 22	17,63 145	2,13 235	2,13 235	T20	12,83 114	2,13 232	2,13 232
84 190 612	ER 16 / IL 16	16,39 101	ER 16 / IL 16	12,16 121	1,41 234	1,41 234	T10	11,78 112	1,41 231	1,41 231
84 191 612	EL 16 / IR 16	16,39 108	EL 16 / IR 16	11,07 129	1,41 234	1,41 234	T10	11,78 112	1,41 231	1,41 231
84 190 622			ER 22 / IL 22	17,63 137	2,13 235	2,13 235	T20	12,83 114	2,13 232	2,13 232
84 191 622			EL 22 / IR 22	17,63 145	2,13 235	2,13 235	T20	12,83 114	2,13 232	2,13 232
84 190 822			ER 22 / IL 22	17,63 137	2,13 235	2,13 235	T20	12,83 114	2,13 232	2,13 232
84 191 822			EL 22 / IR 22	17,63 145	2,13 235	2,13 235	T20	12,83 114	2,13 232	2,13 232

Shims for correction of helix angle see page → Page 43.

Standard Internal Thread Turning Holder

▲ Tool Holder with Approach Angle $\beta = 1,5^\circ$

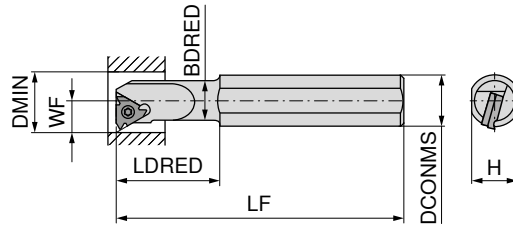

Illustrations show right-hand versions



ISO designation	H mm	LF mm	LDRED mm	DCONMS mm	BDRED mm	WF mm	DMIN mm	Insert	torque moment Nm	Left-hand	Right-hand
										71 283 ...	71 282 ...
SI R 0010 H11	9,0	100	25	10	9,5	7,4	12	11 ..	1,3	EUR Y2	EUR Y2
SI R/L 0010 K11	14,0	125	25	16	10,0	7,4	12	11 ..	1,3	108,40	010 ¹⁾ 108,40 010 ¹⁾
SI R 0013 L11	14,0	140	32	16	12,0	8,9	15	11 ..	1,3		116,10 013 ¹⁾
SI R/L 0013 M16	14,0	150	32	16	13,0	10,2	16	16 ..	3,5	118,20	015 ¹⁾ 118,20 015 ¹⁾
SI R/L 0016 P16	18,0	170	40	20	15,0	11,7	19	16 ..	3,5	118,20	016 ¹⁾ 118,20 016 ¹⁾
SI R/L 0020 P16	18,0	170	40	20	19,5	13,7	24	16 ..	3,5	139,30	020 139,30 020
SI R 0025 R16	22,6	200	40	25	24,5	16,2	29	16 ..	3,5		169,00 026
SI R/L 0032 S16	28,8	250	50	32	31,5	19,7	36	16 ..	3,5	182,60	032 182,60 032
SI R 0040 T16	36,0	300	50	40	39,5	23,7	44	16 ..	3,5		270,40 040
SI R 0020 P22	18,0	170	40	20	19,5	15,6	24	22 ..	10		131,70 120 ¹⁾
SI R/L 0025 R22	22,6	200	40	25	24,5	18,1	29	22 ..	10	169,00	126 169,00 126
SI R 0032 S22	28,8	250	50	32	31,5	21,6	38	22 ..	10		187,90 132
SI R 0040 T22	36,0	300	60	40	39,5	25,6	46	22 ..	10		277,30 140
SI R 0032 S22U	28,8	250	60	32	31,5	24,4	38	22..N	10		158,20 133 ²⁾

1) without shim

2) Neutral insert indicated by marking (N)



Multi tooth shim



Shim

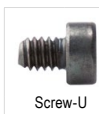

Screw-U

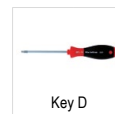

Key D



Clamping screw

Spare parts for Article no.	71 950 ...		71 950 ...		71 950 ...		80 950 ...		71 950 ...	
	EUR Y2		EUR Y2		EUR Y2		EUR Y7		EUR Y2	
71 282 011							T08	10,05	110	1,41 230
71 282 010 / 71 283 010							T08	10,05	110	1,41 230
71 282 013							T08	10,05	110	1,41 230
71 282 015 / 71 283 015							T10	11,78	112	2,12 236
71 282 016 / 71 283 016							T10	11,78	112	2,12 236
71 282 020	EL 16 / IR 16	16,39 108	EL 16 / IR 16	11,07 129	1,41 234		T10	11,78	112	1,41 231
71 283 020	ER 16 / IL 16	16,39 101	ER 16 / IL 16	12,16 121	1,41 234		T10	11,78	112	1,41 231
71 282 026	EL 16 / IR 16	16,39 108	EL 16 / IR 16	11,07 129	1,41 234		T10	11,78	112	1,41 231
71 282 032	EL 16 / IR 16	16,39 108	EL 16 / IR 16	11,07 129	1,41 234		T10	11,78	112	1,41 231
71 283 032	ER 16 / IL 16	16,39 101	ER 16 / IL 16	12,16 121	1,41 234		T10	11,78	112	1,41 231
71 282 040	EL 16 / IR 16	16,39 108	EL 16 / IR 16	11,07 129	1,41 234		T10	11,78	112	1,41 231
71 282 120					1,41 234		T20	12,83	114	2,13 237
71 282 126			EL 22 / IR 22	17,63 145	2,13 235		T20	12,83	114	2,13 232
71 283 126			ER 22 / IL 22	17,63 137	2,13 235		T20	12,83	114	2,13 232
71 282 132			EL 22 / IR 22	17,63 145	2,13 235		T20	12,83	114	2,13 232
71 282 140			EL 22 / IR 22	17,63 145	2,13 235		T20	12,83	114	2,13 232
71 282 133			AL 22U / IR 22U	17,63 161	2,13 235		T20	12,83	114	2,13 232

1 Shims for correction of helix angle see page → Page 43.

Standard Internal Thread Turning Holder with thro' coolant

▲ Tool Holder with Approach Angle $\beta = 1,5^\circ$

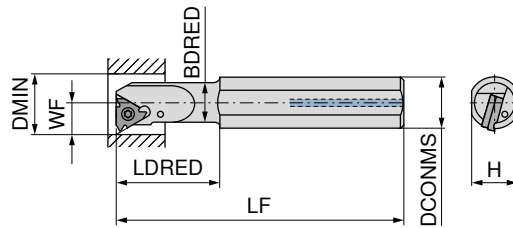

Illustrations show right-hand versions



ISO designation	H mm	LF mm	LDRED mm	DCONMS mm	BDRED mm	WF mm	DMIN mm	Insert	torque moment Nm	Left-hand	Right-hand
										71 283 ...	71 282 ...
SI R 0010 M11CB	9,0	150	25	10	9,5	7,4	12	11 ..	1,3	EUR Y2	EUR Y2
SI R 0012 P11CB	11,0	170	30	12	11,5	8,4	15	11 ..	1,3		452,00 510 ²⁾
SI R/L 0010 K11B	14,0	125	25	16	10,0	7,4	12	11 ..	1,3	129,90 310	129,90 310
SI R/L 0013 M16B	14,0	150	32	16	13,0	10,2	16	16 ..	3,5	142,00 315	142,00 315
SI R 0016 P16B	18,0	170	40	20	16,0	11,7	19	16 ..	3,5		142,00 316
SI R 0020 P16B	18,0	170	40	20	19,5	13,7	24	16 ..	3,5		166,20 320 ¹⁾
SI R/L 0032 S16B	28,8	250	50	32	31,5	19,7	36	16 ..	3,5	205,50 332 ¹⁾	205,50 332 ¹⁾

- 1) with shim seat
- 2) Carbide version

Spare parts for Article no.	Multi tooth shim		Shim		Screw-U		Key D		Clamping screw	
	71 950 ...	EUR Y2	71 950 ...	EUR Y2	71 950 ...	EUR Y2	80 950 ...	EUR Y7	71 950 ...	EUR Y2
71 282 510							T08	10,05 110	1,41 230	
71 282 512							T08	10,05 110	1,41 230	
71 282 310 / 71 283 310							T08	10,05 110	1,41 230	
71 282 315 / 71 283 315							T10	11,78 112	2,12 236	
71 282 316							T10	11,78 112	2,12 236	
71 282 320	EL 16 / IR 16	16,39 108	EL 16 / IR 16	11,07 129	1,41 234		T10	11,78 112	1,41 231	
71 282 332	EL 16 / IR 16	16,39 108	EL 16 / IR 16	11,07 129	1,41 234		T10	11,78 112	1,41 231	
71 283 332	ER 16 / IL 16	16,39 101	ER 16 / IL 16	12,16 121	1,41 234		T10	11,78 112	1,41 231	

Shims for correction of helix angle see page → Page 43.

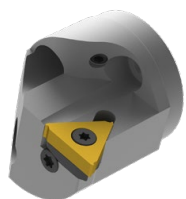

Do you already know our MaxiChange exchangeable head system?

Use our thread turning inserts with the MaxiChange exchangeable head system.

Further information and products can be found in the → Chapter 9 – Turning Tools

Internal threading holder

▲ Tool Holder with Approach Angle $\beta = 1,5^\circ$

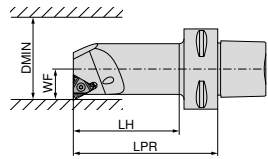

Illustrations show right-hand versions

ISO designation	Adapter	WF mm	LPR mm	LH mm	DMIN mm	Insert	torque moment Nm	Left-hand 84 197 ...		Right-hand 84 196 ...	
								EUR Y8		EUR Y8	
PSC40 SI R/L 12060-16.IK	PSC 40	12	60	37	20	16 ..	3,5	431,20	410	431,20	410
PSC40 SI R/L 14060-16.IK	PSC 40	14	60	38	25	16 ..	3,5	431,20	412	431,20	412
PSC40 SI R/L 17070-16.IK	PSC 40	17	70	48	32	16 ..	3,5	431,20	414	431,20	414
PSC40 SI R/L 22090-16.IK	PSC 40	22	90	69	40	16 ..	3,5	431,20	416	431,20	416
PSC40 SI R/L 27080-16.IK	PSC 40	27	80	60	50	16 ..	3,5	431,20	418	431,20	418
PSC40 SI R/L 15065-22.IK	PSC 40	15	65	42	25	22 ..	10	431,20	420	431,20	420
PSC40 SI R/L 19070-22.IK	PSC 40	19	70	48	32	22 ..	10	431,20	422	431,20	422
PSC40 SI R/L 22090-22.IK	PSC 40	22	90	69	40	22 ..	10	431,20	424	431,20	424
PSC40 SI R/L 27080-22.IK	PSC 40	27	80	60	50	22 ..	10	431,20	426	431,20	426
PSC50 SI R/L 12060-16.IK	PSC 50	12	60	35	20	16 ..	3,5	480,00	510	480,00	510
PSC50 SI R/L 14060-16.IK	PSC 50	14	60	36	25	16 ..	3,5	480,00	512	480,00	512
PSC50 SI R/L 17070-16.IK	PSC 50	17	70	47	32	16 ..	3,5	480,00	514	480,00	514
PSC50 SI R/L 22090-16.IK	PSC 50	22	90	68	40	16 ..	3,5	480,00	516	480,00	516
PSC50 SI R/L 27105-16.IK	PSC 50	27	105	84	50	16 ..	3,5	480,00	518	480,00	518
PSC50 SI R/L 15065-22.IK	PSC 50	15	65	41	25	22 ..	10	480,00	520	480,00	520
PSC50 SI R/L 19070-22.IK	PSC 50	19	70	47	32	22 ..	10	480,00	522	480,00	522
PSC50 SI R/L 22090-22.IK	PSC 50	22	90	68	40	22 ..	10	480,00	524	480,00	524
PSC50 SI R/L 27105-22.IK	PSC 50	27	105	84	50	22 ..	10	480,00	526	480,00	526
PSC63 SI R/L 14070-16.IK	PSC 63	14	70	42	25	16 ..	3,5	551,60	610	551,60	610
PSC63 SI R/L 17075-16.IK	PSC 63	17	75	48	32	16 ..	3,5	551,60	612	551,60	612
PSC63 SI R/L 22090-16.IK	PSC 63	22	90	64	40	16 ..	3,5	551,60	614	551,60	614
PSC63 SI R/L 27105-16.IK	PSC 63	27	105	80	50	16 ..	3,5	551,60	616	551,60	616
PSC63 SI R/L 19075-22.IK	PSC 63	19	75	48	32	22 ..	10	551,60	620	551,60	620
PSC63 SI R/L 22090-22.IK	PSC 63	22	90	64	40	22 ..	10	551,60	622	551,60	622
PSC63 SI R/L 27105-22.IK	PSC 63	27	105	80	50	22 ..	10	551,60	624	551,60	624



Multi tooth shim



Shim

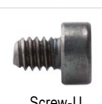

Screw-U

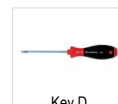

Key D

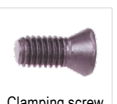

Clamping screw

Spare parts	Insert	71 950 ...		71 950 ...		71 950 ...		80 950 ...		71 950 ...				
		EUR Y2		EUR Y2		EUR Y2		EUR Y7		EUR Y2				
16 ..	right	EL 16 / IR 16	16,39	108	EL 16 / IR 16	11,07	129	1,41	234	T10	11,78	112	1,41	231
16 ..	left	ER 16 / IL 16	16,39	101	ER 16 / IL 16	12,16	121	1,41	234	T10	11,78	112	1,41	231
22 ..	left				ER 22 / IL 22	17,63	137	2,13	235	T20	12,83	114	2,13	232
22 ..	right				EL 22 / IR 22	17,63	145	2,13	235	T20	12,83	114	2,13	232

Shims for correction of helix angle see page → Page 43.

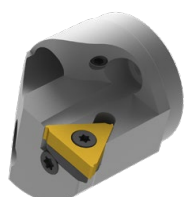

Do you already know our MaxiChange exchangeable head system?

Use our thread turning inserts with the MaxiChange exchangeable head system.

Further information and products can be found in the → Chapter 9 – Turning Tools

Right hand internal thread turning insert – Mini size 06

- ▲ Full profile
- ▲ Thread production from diameter 6 mm

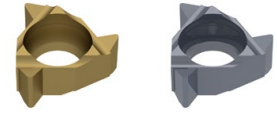
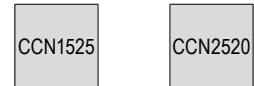
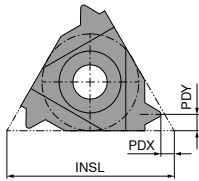
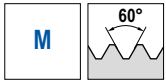

Designation	TP mm	PDX mm	PDY mm	INSL mm
06 IR 0,5	0,50	0,9	0,5	6
06 IR 0,75	0,75	0,8	0,5	6
06 IR 1,0	1,00	0,7	0,6	6
06 IR 1,25	1,25	0,6	0,6	6

IR 71 271 ...		IR 71 224 ...	
EUR		EUR	
X3		X3	
29,40	110	31,68	35700
29,40	112	31,68	36100
29,40	114	31,68	36500
29,40	116	31,68	36700

P	●	○
M	●	●
K	●	○
N	○	○
S	○	●
H	○	○
O	○	○

→ v_c Page 45

Right hand internal thread turning insert – Mini size 06

- ▲ Full profile
- ▲ Thread production from diameter 6 mm

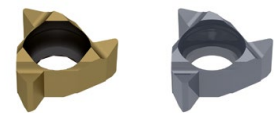
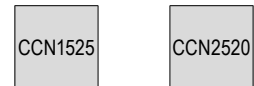
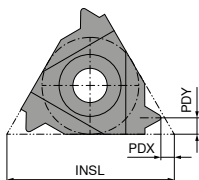

Designation	TPI 1/"	PDX mm	PDY mm	INSL mm
06 IR 26	26	0,7	0,6	6
06 IR 22	22	0,6	0,6	6
06 IR 20	20	0,6	0,7	6
06 IR 18	18	0,6	0,7	6

IR 71 230 ...		IR 71 230 ...	
EUR		EUR	
X3		X3	
29,40	13500	31,68	33500
29,40	13100	31,68	33100
29,40	12900	31,68	32900
29,40	12500	31,68	32500

P	●	○
M	●	●
K	●	○
N	○	○
S	○	●
H	○	○
O	○	○

→ v_c Page 45

Right hand internal thread turning insert – Mini size 06

- ▲ Partial profile
- ▲ Thread production from diameter 6 mm

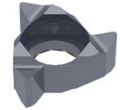
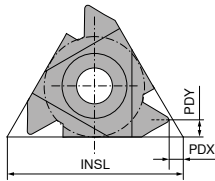

Designation	TP mm	INSL mm	PDX mm	PDY mm
06 IR A60	0,5 - 1,25	6	0,6	0,6

	IR 71 274 ...	IR 71 272 ...
P	●	○
M	●	●
K	●	○
N	○	○
S	○	●
H	○	○
O	○	○

IR 71 274 ...	IR 71 272 ...
EUR X3 29,40	EUR X3 31,68
210	30000

→ v_c Page 45

Right hand internal thread turning insert – Mini size 06

- ▲ Partial profile
- ▲ Thread production from diameter 6 mm

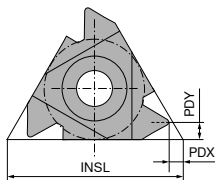

Designation	TPI 1/"	INSL mm	PDX mm	PDY mm
06 IR A55	48 - 20	6	0,5	0,6

	IR 71 272 ...	IR 71 272 ...
P	●	○
M	●	●
K	●	○
N	○	○
S	○	●
H	○	○
O	○	○

IR 71 272 ...	IR 71 272 ...
EUR X3 29,40	EUR X3 31,68
10100	30100

→ v_c Page 45

Right hand internal thread turning insert – Mini size 08

- ▲ Full profile
- ▲ Thread production from diameter 8 mm

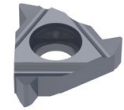
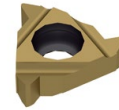
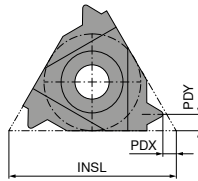
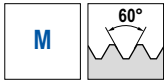

Designation	TP mm	PDX mm	PDY mm	INSL mm
08 IR 0,5	0,50	0,6	0,5	8
08 IR 0,75	0,75	0,6	0,5	8
08 IR 1,0	1,00	0,6	0,6	8
08 IR 1,25	1,25	0,6	0,7	8
08 IR 1,5	1,50	0,6	0,7	8
08 IR 1,75	1,75	0,6	0,8	8
08 IN 2,0	2,00	0,9	4,0	8

IR		IR	
71 224 ...		71 224 ...	
EUR		EUR	
X3		X3	
31,68	14300	31,68	34300
31,68	13700	31,68	33700
31,68	13300	31,68	33300
31,68	13100	31,68	33100
31,68	12900	31,68	32900
31,68	12700	31,68	32700
31,68	12500 ¹⁾	31,68	32500 ¹⁾

P	●	○
M	●	●
K	●	○
N	○	○
S	○	●
H	○	○
O	○	○

1) Neutral version (N)

→ v_c Page 45

Right hand internal thread turning insert – Mini size 08

- ▲ Partial profile
- ▲ Thread production from diameter 8 mm

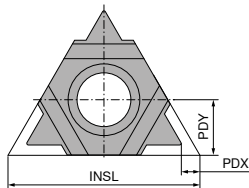

Designation	TP mm	INSL mm	PDX mm	PDY mm
08 IN M60	1,75 - 2,0	8	0,8	4

IN		IN	
71 273 ...		71 273 ...	
EUR		EUR	
X3		X3	
31,68	10800	31,68	30800

P	●	○
M	●	●
K	●	○
N	○	○
S	○	●
H	○	○
O	○	○

→ v_c Page 45

Right hand internal thread turning insert – Mini size 08

- ▲ Partial profile
- ▲ Thread production from diameter 8 mm

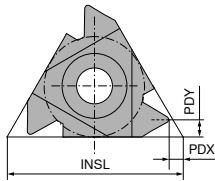

Designation	TP mm	PDX mm	PDY mm	INSL mm
08 IR A60	0,5 - 1,25	0,6	0,6	8
08 IR A60	0,5 - 1,5	0,6	0,7	8

IR		IR	
71 272 ...	71 272 ...	71 272 ...	71 272 ...
EUR X3	EUR X3	EUR X3	EUR X3
31,68	10600	31,68	30600

P	●	○
M	●	●
K	●	○
N	○	○
S	○	●
H	○	○
O	○	○

→ v_c Page 45

Right hand internal thread turning insert – Mini size 08

- ▲ Partial profile
- ▲ Thread production from diameter 8 mm

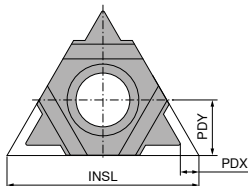

Designation	TPI 1/"	INSL mm	PDX mm	PDY mm
08 IN M55	14 - 11	8	0,9	4

IN		IN	
71 273 ...	71 273 ...	71 273 ...	71 273 ...
EUR X3	EUR X3	EUR X3	EUR X3
31,68	10900	31,68	30900

P	●	○
M	●	●
K	●	○
N	○	○
S	○	●
H	○	○
O	○	○

→ v_c Page 45

Right hand internal thread turning insert – Mini size 08

▲ Partial profile

▲ Thread production from diameter 8 mm

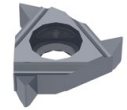
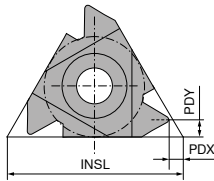

Designation	TPI 1/"	INSL mm	PDX mm	PDY mm
08 IR A55	48 - 16	8	0,6	0,7

IR		IR	
71 272 ...		71 272 ...	
EUR		EUR	
X3		X3	
31,68	10700	31,68	30700

P	●	○
M	●	●
K	●	○
N	○	
S		●
H		○
O	○	

→ v_c Page 45

Right Hand Internal Thread Holder – Mini size 06

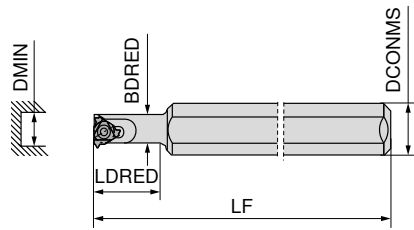

Right-hand

71 282 ...

ISO designation	LF mm	LDRED mm	DCONMS mm	BDRED mm	DMIN mm	Insert	torque moment Nm
SI R 0005 H06	100	12	12	5,1	6	06 ..	0,6
SI R 0005 H06 C	100	26	6	5,1	6	06 ..	0,6

EUR
Y2

144,70 00500

270,10 10500¹⁾

1) Solid Carbide Shank with Thro' Coolant

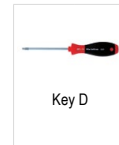

Key D

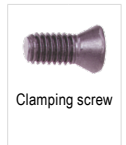

Clamping screw

80 950 ...

EUR
Y7

71 950 ...

EUR
Y2

Spare parts
for Article no.

71 282 00500	T06	10,87	108	2,64	23800
71 282 10500	T06	10,87	108	2,64	23800

Right Hand Internal Thread Holder – Mini size 08

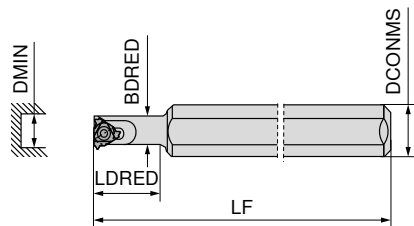

Right-hand

71 282 ...

ISO designation	LF mm	LDRED mm	DCONMS mm	BDRED mm	DMIN mm	Insert	torque moment Nm
SI R 0007 K08	125	18	16	6,6	7,8	08 ..	0,6
SI R 0008 K08U	125	21	16	7,3	9,0	08 .N	0,6
SI R 0007 K08CB	125	31	8	6,6	7,8	08 ..	0,6

EUR
Y2

144,70 00700

162,40 00800¹⁾

339,10 10700²⁾

1) Neutral insert indicated by marking (N)

2) Solid Carbide Shank with Thro' Coolant

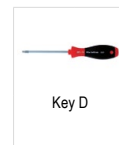

Key D



Clamping screw

80 950 ...

EUR
Y7

71 950 ...

EUR
Y2

Spare parts
for Article no.

71 282 00700	T06	10,87	108	2,78	23900
71 282 00800	T06	10,87	108	2,78	23900
71 282 10700	T06	10,87	108	2,78	23900

Shims for Standard Threading Inserts

- ▲ Use the formula on page 47 to calculate the required correction angle α (\pm).
- ▲ Then find the corresponding correction plate below.



Pitch-angle β	Correction angle α	AE 16 ER 16 / IL 16		AI 16 EL 16 / IR 16		AE 22 ER 22 / IL 22		AI 22 EL 22 / IR 22		AE 22 U ER 22 / IL 22		AI 22 U EL 22 / IR 22		AE 16 M ER 16 / IL 16		AI 16 M EL 16 / IR 16	
		71 950 ...		71 950 ...		71 950 ...		71 950 ...		71 950 ...		71 950 ...		71 950 ...		71 950 ...	
		EUR	Y2	EUR	Y2	EUR	Y2	EUR	Y2	EUR	Y2	EUR	Y2	EUR	Y2	EUR	Y2
+ 4,5°	+ 3°	13,91	118	13,91	126	22,32	134	22,32	142	22,32	150 ¹⁾	22,32	158 ¹⁾				
+ 3,5°	+ 2°	13,91	119	13,91	127	22,32	135	22,32	143	22,32	151 ¹⁾	22,32	159 ¹⁾				
+ 2,5°	+ 1°	13,91	120	13,91	128	22,32	136	22,32	144	22,32	152 ¹⁾	22,32	160 ¹⁾				
+ 1,5°	0°	12,16	121	11,07	129	17,63	137	17,63	145	17,63	153 ¹⁾	17,63	161 ¹⁾	16,39	101	16,39	108
+ 0,5°	- 1°	13,91	122	13,91	130	22,32	138	22,32	146	22,32	154 ¹⁾	22,32	162 ¹⁾				
0°	- 1,5°	13,91	123	13,91	131	22,32	139	22,32	147								
- 0,5°	- 2°	13,91	124	13,91	132	22,32	140	22,32	148	22,32	156 ¹⁾	22,32	164 ¹⁾				
- 1,5°	- 3°	13,91	125	13,91	133	22,32	141	22,32	149	22,32	157 ¹⁾	22,32	165 ¹⁾				

1) Neutral version for tool holder identified by (U).

Flank clearance angle and effective approach angle

The angle of inclination λ of the cutting edges, in concert with the thread approach angle β ensures an equal rake angle and side clearance angle on both thread flanks.

8

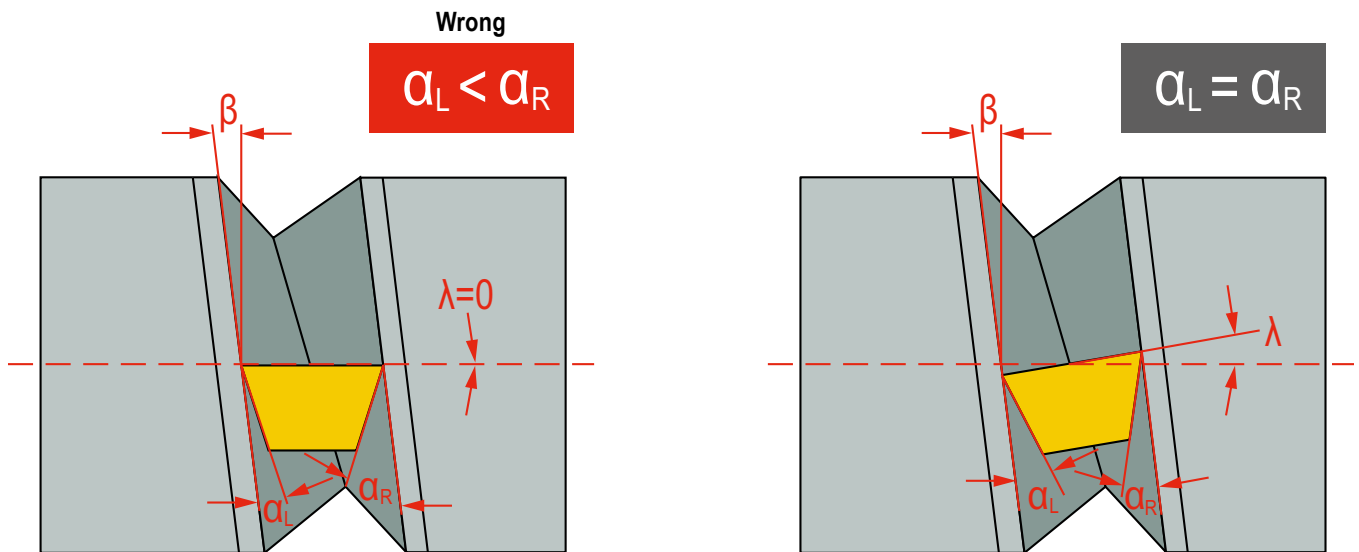

- α = Side clearance angle
- λ = Pitch angle
- β = An effective angle of inclination is achieved by using a suitable insert seat

Material examples for cutting data tables

	Material sub-group	Index	Composition / Structure / Heat treatment	Tensile strength N/mm ² / HB / HRC	Material number	Material designation	Material number	Material designation
P	Unalloyed steel	P.1.1	< 0,15 % C Annealed	420 N/mm ² / 125 HB	1.0401	C15	1.1141	Ck15
		P.1.2	< 0,45 % C Annealed	640 N/mm ² / 190 HB	1.1191	C45E	1.0718	9SMnPb28
		P.1.3	< 0,45 % C Tempered	840 N/mm ² / 250 HB	1.1191	C45E	1.0535	C55
		P.1.4	< 0,75 % C Annealed	910 N/mm ² / 270 HB	1.1223	C60R	1.0535	C55
		P.1.5	< 0,75 % C Tempered	1010 N/mm ² / 300 HB	1.1223	C60R	1.0727	45S20
	Low-alloy steel	P.2.1	Annealed	610 N/mm ² / 180 HB	1.7131	16MnCr5	1.6587	17CrNiMo6
		P.2.2	Tempered	930 N/mm ² / 275 HB	1.7131	16MnCr5	1.6587	17CrNiMo6
		P.2.3	Tempered	1010 N/mm ² / 300 HB	1.7225	42CrMo4	1.3505	100Cr6
		P.2.4	Tempered	1200 N/mm ² / 375 HB	1.7225	42CrMo4	1.3505	100Cr6
	High-alloy steel and high-alloy tool steel	P.3.1	Annealed	680 N/mm ² / 200 HB	1.4021	X20Cr13	1.4034	X46Cr13
		P.3.2	Hardened and tempered	1100 N/mm ² / 300 HB	1.2343	X38CrMoV5-1	1.4034	X46Cr13
		P.3.3	Hardened and tempered	1300 N/mm ² / 400 HB	1.2343	X38CrMoV5-1	1.4034	X46Cr13
	Stainless steel	P.4.1	Ferritic / martensitic Annealed	680 N/mm ² / 200 HB	1.4016	X6Cr17	1.2316	X36CrMo16
		P.4.2	Martensitic Tempered	1010 N/mm ² / 300 HB	1.4112	X90CrMoV18	1.2316	X36CrMo16
M	Stainless steel	M.1.1	Austenitic / austenitic-ferritic Quenched	610 N/mm ² / 180 HB	1.4301	X5CrNi18-10	1.4571	X6CrNiMoTi17-12-2
		M.2.1	Austenitic Tempered	300 HB	1.4841	X15CrNiSi25-21	1.4539	X1NiCrMoCu25-20-5
		M.3.1	Austenitic / ferritic (Duplex)	780 N/mm ² / 230 HB	1.4462	X2CrNiMoN22-5-3	1.4501	X2CrNiMoCuWN25-7-4
K	Grey cast iron	K.1.1	Pearlitic / ferritic	350 N/mm ² / 180 HB	0.6010	GG-10	0.6025	GG-25
		K.1.2	Pearlitic (martensitic)	500 N/mm ² / 260 HB	0.6030	GG-30	0.6045	GG-45
	Spherulitic graphite cast iron	K.2.1	Ferritic	540 N/mm ² / 160 HB	0.7040	GGG-40	0.7060	GGG-60
		K.2.2	Pearlitic	845 N/mm ² / 250 HB	0.7070	GGG-70	0.7080	GGG-80
	Malleable iron	K.3.1	Ferritic	440 N/mm ² / 130 HB	0.8035	GTW-35-04	0.8045	GTW-45
		K.3.2	Pearlitic	780 N/mm ² / 230 HB	0.8165	GTS-65-02	0.8170	GTS-70-02
N	Aluminium wrought alloy	N.1.1	Non-hardenable	60 HB	3.0255	Al99,5	3.3315	AlMg1
		N.1.2	Hardenable Age-hardened	340 N/mm ² / 100 HB	3.1355	AlCuMg2	3.2315	AlMgSi1
	Cast aluminium alloy	N.2.1	≤ 12 % Si, non-hardenable	250 N/mm ² / 75 HB	3.2581	G-AlSi12	3.2163	G-AlSi9Cu3
		N.2.2	≤ 12 % Si, hardenable Age-hardened	300 N/mm ² / 90 HB	3.2134	G-AlSi5Cu1Mg	3.2373	G-AlSi9Mg
		N.2.3	> 12 % Si, non-hardenable	440 N/mm ² / 130 HB		G-AlSi17Cu4Mg		G-AlSi18CuNiMg
	Copper and copper alloys (bronze/brass)	N.3.1	Free-machining alloys, PB > 1 %	375 N/mm ² / 110 HB	2.0380	CuZn39Pb2 (Ms58)	2.0410	CuZn44Pb2
		N.3.2	CuZn, CuSnZn	300 N/mm ² / 90 HB	2.0331	CuZn15	2.4070	CuZn28Sn1As
		N.3.3	CuSn, lead-free copper and electrolytic copper	340 N/mm ² / 100 HB	2.0060	E-Cu57	2.0590	CuZn40Fe
	Magnesium alloys	N.4.1	Magnesium and magnesium alloys	70 HB	3.5612	MgAl6Zn	3.5312	MgAl3Zn
	S	Heat-resistant alloys	S.1.1	Fe - basis Annealed	680 N/mm ² / 200 HB	1.4864	X12NiCrSi 36-16	1.4865
S.1.2			Fe - basis Age-hardened	950 N/mm ² / 280 HB	1.4980	X6NiCrTiMoVB25-15-2	1.4876	X10NiCrAlTi32-20
S.2.1			Ni or Co basis Annealed	840 N/mm ² / 250 HB	2.4631	NiCr20TiAl (Nimonic80A)	3.4856	NiCr22Mo9Nb
S.2.2			Ni or Co basis Age-hardened	1180 N/mm ² / 350 HB	2.4668	NiCr19Nb5Mo3 (Inconel 718)	2.4955	NiFe25Cr20NbTi
S.2.3			Ni or Co basis Cast	1080 N/mm ² / 320 HB	2.4765	CoCr20W15Ni	1.3401	G-X120Mn12
Titanium alloys		S.3.1	Pure titanium	400 N/mm ²	3.7025	Ti99,8	3.7034	Ti99,7
		S.3.2	Alpha + beta alloys Age-hardened	1050 N/mm ² / 320 HB	3.7165	TiAl6V4	Ti-6246	Ti-6Al-2Sn-4Zr-6Mo
S.3.3	Beta alloys	1400 N/mm ² / 410 HB	Ti555.3	Ti-5Al-5V-5Mo-3Cr	R56410	Ti-10V-2Fe-3Al		
H	Hardened steel	H.1.1	Hardened and tempered	46–55 HRC				
		H.1.2	Hardened and tempered	56–60 HRC				
		H.1.3	Hardened and tempered	61–65 HRC				
		H.1.4	Hardened and tempered	66–70 HRC				
	Chilled iron	H.2.1	Cast	400 HB				
Hardened cast iron	H.3.1	Hardened and tempered	55 HRC					
O	Non-metal materials	O.1.1	Plastics, duroplastic	≤ 150 N/mm ²				
		O.1.2	Plastics, thermoplastic	≤ 100 N/mm ²				
		O.2.1	Aramid fibre-reinforced	≤ 1000 N/mm ²				
		O.2.2	Glass/carbon-fibre reinforced	≤ 1000 N/mm ²				
		O.3.1	Graphite					

* Tensile strength

Cutting data standard values

Index	CCN1525	CCN2520	CWN1525	HCN2525	CCN7525	CCN20	CWK20
	Mini	Mini					
	v _c (m/min)						
P.1.1	80	120	120	120	120	120	
P.1.2	80	120	120	120	120	120	
P.1.3	80	120	120	120	120	120	
P.1.4	80	80	80	90	80	80	
P.1.5	70	80	80	90	80	80	
P.2.1	50	80	80	90	80	80	
P.2.2	50	80	80	90	80	80	
P.2.3	50	80	80	90	80	80	
P.2.4	50	80	80	90	80	80	
P.3.1	50	50	60	70	50	50	
P.3.2	50	50	60	70	50	50	
P.3.3	50	50	60	70	50	50	
P.4.1	50	50	60	70	50	50	
P.4.2	50	50	60	70	50	50	
M.1.1	40	90	60	110	90	60	40
M.2.1	40	90	60	110	90	60	40
M.3.1	40	90	60	110	90	60	40
K.1.1	60	120	90	140	120	120	80
K.1.2	60	120	90	140	120	120	80
K.2.1	60	100	80	120	100	100	70
K.2.2	60	100	80	120	100	100	70
K.3.1	50	100	80	110	100	100	70
K.3.2	50	100	80	110	100	100	70
N.1.1	500		600	700			150
N.1.2	300		600	700			150
N.2.1	120		250	280			120
N.2.2	120		250	280			120
N.2.3	120		250	280			120
N.3.1	110		150	190			100
N.3.2	150		150	190			100
N.3.3	150		150	190			100
N.4.1	300		300	220			150
S.1.1		25		20	25	20	20
S.1.2		25		20	25	20	20
S.2.1		25		20	25	20	20
S.2.2		25		20	25	20	20
S.2.3		25		20	25	20	20
S.3.1		35		30	35	30	30
S.3.2		35		30	35	30	30
S.3.3		35		30	35	30	30
H.1.1		35		30	35	30	
H.1.2		35		30	35	30	
H.1.3		35		30	35	30	
H.1.4		35		30	35	30	
H.2.1		25		20	25	20	
H.3.1		25		20	25	20	
O.1.1	150		200				
O.1.2	150		200				
O.2.1	150		200				
O.2.2	150		200				
O.3.1	150		200				

8



The cutting data depends extremely on the external conditions, the material and machine type.
The indicated values are possible values which have to be increased or reduced according to the application conditions.

Thread turning methods

External right-hand thread

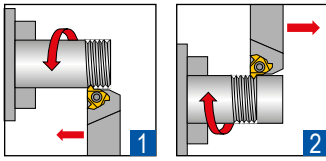

External left-hand thread

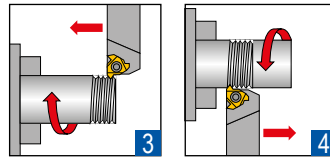

Internal right-hand thread

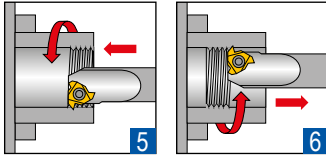

Internal left-hand thread

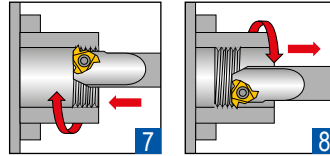

i The machining examples 2, 4, 6 and 8 require negative shims!
These shims can be found on → **Page 43.**

Thread infeed methods

Radial Infeed

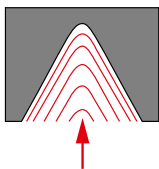

- ▲ for pitches less than 1.5 mm
- ▲ for short chipping materials
- ▲ for machining hardened materials
- ▲ simple and quick method

Flank infeed

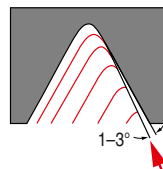

- ▲ for pitches larger than 1.5 mm
- ▲ with radial penetration the effective cutting edge length is too large, which may lead to chattering
- ▲ with trapezoidal and ACME threads, chip flow on three sides can be problematic

Alternating infeed

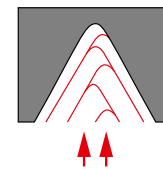

- ▲ with large pitches
- ▲ for long chipping materials
- ▲ uniform wear of the cutting edges
- ▲ complicated programming process

Recommended number of cuts and cutting depths

Standard Threading Inserts

Pitch (TP/TPI)	mm	0,50	0,75	1,00	1,25	1,50	1,75	2,00	2,50	3,00	3,50	4,00	4,50	5,00	5,50	6,00	8,00
	TPI	48	32	24	20	16	14	12	10	8	7	6	5,5	5	4,5	4	3
Number of passes		4-6	4-7	4-8	5-9	6-10	7-12	7-12	8-14	9-16	10-18	11-18	11-19	12-20	12-20	12-20	15-24
Number of passes	(CCN7525)	3-4	3-4	3-5	4-6	5-6	6-8	6-8	8-10								
Number of passes	Mini Inserts	6-9	6-11	6-12	8-14	9-15	11-18	11-18									

Multi edge thread turning insert

Standard	Insert	Insert size		Pitch (TP)	Number of flutes (NT)	Designation	Passes	Cutting depth per pass		
		IC	L mm					1	2	3
ISO external	M	3/8"	16	1,0 mm	3	3 ER 1.0 ISO 3M	2	0,38	0,25	
ISO external	M	3/8"	16	1,5 mm	2	3 ER 1.5 ISO 2M	3	0,42	0,30	0,20

Pitch angle

Important Information about Standard Shims

- ▲ the pitch angle should be determined through calculation or by using the chart below.
 - ▲ the standard threading holder is supplied with a 1.5° inclined insert seat and a shim without angular correction.
- Hence the Tool holders are delivered with an angle of inclination β of 1.5°.



Without the appropriate correction of the helix angle, the following may occur

- ▲ the profile will be distorted.
- ▲ insufficient clearance angle.
- ▲ the tool life of the insert is greatly reduced.

Method 1: Calculation

Calculating the helix angle β :

$$\beta = \frac{20 \times TP}{DMIN}$$

20 = constant
 β = Helix angle (°)
 TP = Pitch (mm)
 DMIN = Nominal diameter (mm)

For trapezium:

$$\frac{15 \times TP}{DMIN}$$

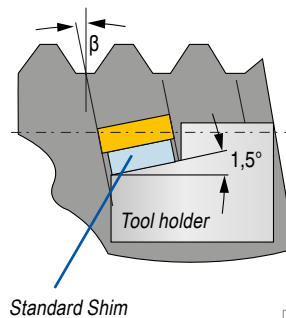

Example calculation

External thread M24 x 1.5
 Feed towards chuck
 DMIN = Nominal Ø: M24 = 24 mm
 TP = Pitch: 1.5 mm

$$\beta = \frac{20 \times 1,5 \text{ mm}}{24 \text{ mm}}$$

$$\beta = 1,25^\circ$$

Method 2: Diagram

From the flank Ø in the diagram, a line is drawn vertically upwards until it intersects with the line of the pitch of the thread to be produced. In the color-coded region in which it is now, a horizontal line to the edge of the chart indicates the appropriate factor.

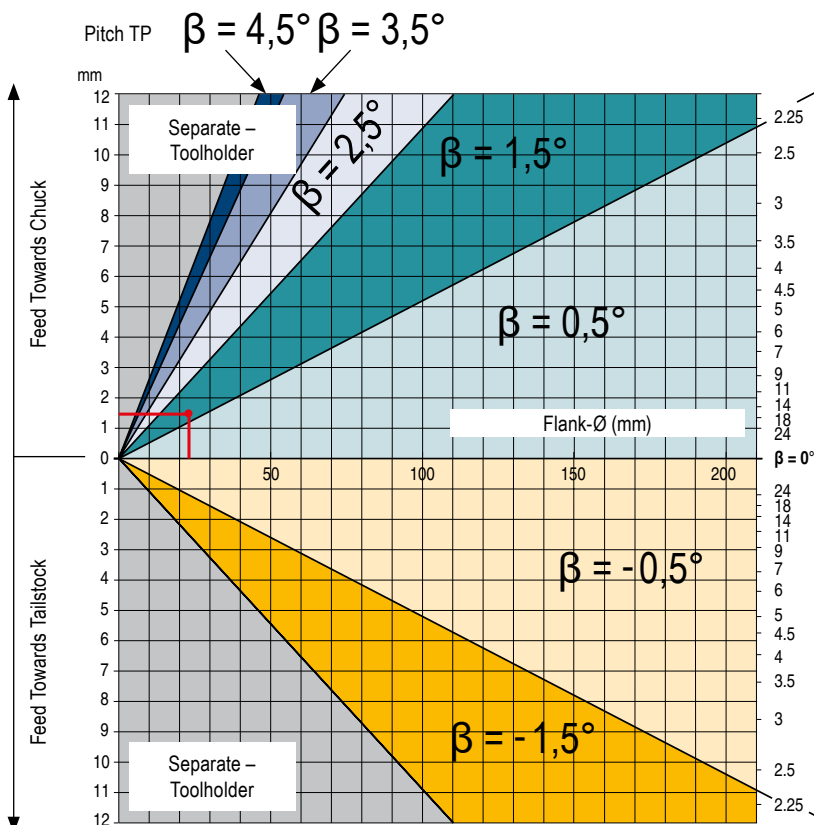

Calculated pitch angle β value	Correction angle α
0,0°–0,49°	-1,5°
0,5°–0,99°	-1°
1,0°–1,99°	0°
2,0°–2,99°	+1°
3,0°–3,99°	+2°
4,0°–4,99°	+3°
0,0°–(-0,49°)	-2°
-0,5°–(-1,5°)	-3°

Designation key – indexable inserts

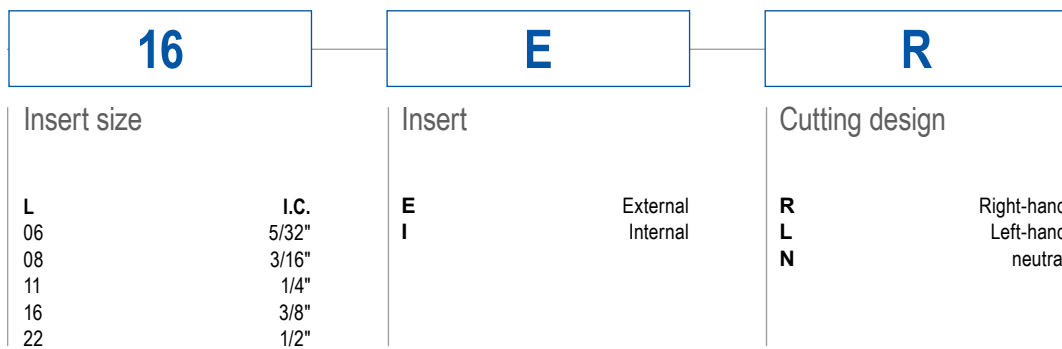

Example

16 ER AG 60

ER16 right hand - external insert with a pitch of 0.5-3.0 mm

Designation key – holders

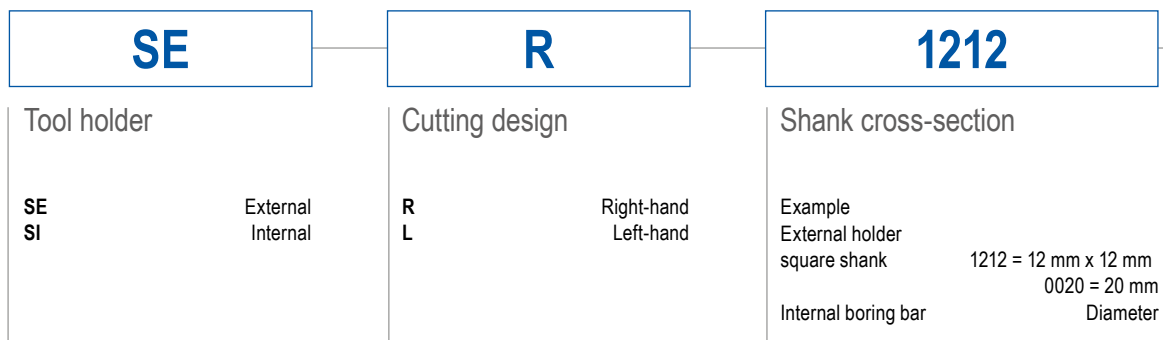

Example

SE R 1212 F 16

Right hand holder with 12 x 12 mm square shank, overall length of 80 mm, only suitable for an ER16 threading insert

AG 60

Pitch (TP/TPI)

Full profile		mm	G/Z
		0,35	72-4
Partial profile		mm	G/Z
A		0,5-1,5	48-16
AG		0,5-3,0	48-8
M		1,7-2,0	14-11
G		1,75-3,0	14-8
N		3,5-5,0	7-5
U		5,5-8,0	4,5-3,5

Flank angle
55°
60°

Number of flutes (NT)

2M	Multi-tooth insert with 2 teeth
3M	Multi-tooth insert with 3 teeth

F

Overall length

	mm
F	80
H	100
K	125
L	140
M	150
P	170
R	200
S	250
T	300

16

Insert size

L	I.C.
06	5/32"
08	3/16"
11	1/4"
16	3/8"
22	1/2"

Properties

B	with thro' coolant
C	with carbide shank
U	neutral holder

Troubleshooting

Edge chipping

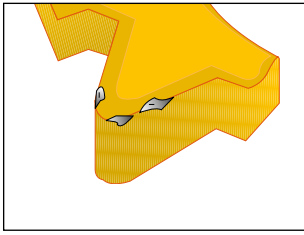

Cause

- ▲ Common in stainless materials
- ▲ Incorrect grade

Remedy

- ▲ Minimize tool overhang length
- ▲ Check that the insert is clamped
- ▲ Minimize vibration
- ▲ Use a tougher grade

Cratering

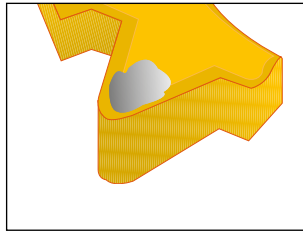

Cause

- ▲ Common in stainless materials
- ▲ Cutting speed too high
- ▲ Incorrect grade

Remedy

- ▲ Apply coolant
- ▲ Reduce depth of cut
- ▲ Use a harder grade

Built-up edge

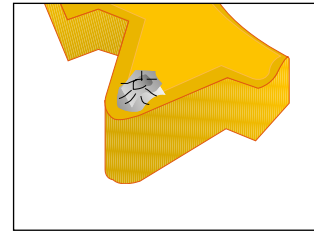

Cause

- ▲ Cutting speed too low
- ▲ Incorrect grade

Remedy

- ▲ Apply coolant
- ▲ Increase cutting speed
- ▲ Use a tougher grade

Thermal cracking

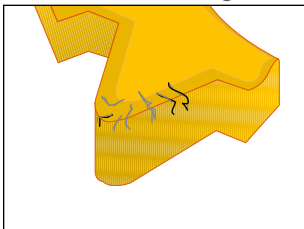

Cause

- ▲ Insufficient coolant
- ▲ Cutting speed too high
- ▲ Incorrect grade

Remedy

- ▲ Apply coolant
- ▲ Reduce cutting speed
- ▲ Use a tougher grade

Plastic deformation

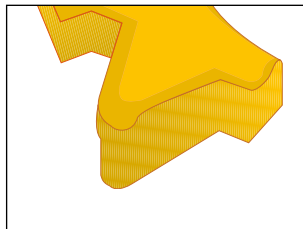

Cause

- ▲ Infeed too large
- ▲ Insufficient coolant
- ▲ Cutting speed too high
- ▲ Incorrect grade

Remedy

- ▲ Apply coolant
- ▲ Reduce depth of cut
- ▲ Reduce cutting speed
- ▲ Use a harder grade

Breakage

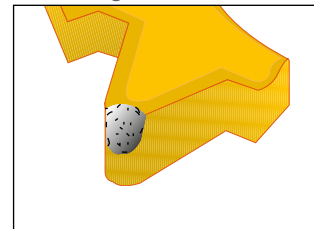

Cause

- ▲ Infeed too large
- ▲ Insufficient coolant
- ▲ Plastic deformation
- ▲ Instability
- ▲ Helix angle not appropriate
- ▲ Incorrect grade

Remedy

- ▲ Reduce depth of cut
- ▲ Check machine and tool stability
- ▲ Reduce cutting speed
- ▲ Check helix angle
- ▲ Use a tougher grade

Grade description

Universal

CCN7525

- ▲ Carbide, TiAlN-coated
- ▲ ISO | **P25** | **M25** | **K25** | **S25** | H25
- ▲ The universal carbide grade with sintered chip breaker for medium to high cutting speeds

CCN2520

- ▲ Carbide, TiAlN-coated
- ▲ ISO | **P25** | **M25** | **K25** | **S25** | H25
- ▲ The coated carbide grade for the machining of stainless steels at medium to high cutting speeds

CCN1525

- ▲ Carbide, TiN-coated
- ▲ ISO | **P25** | **M25** | **K25** | N25 | O25
- ▲ The coated carbide grade for machining steels and stainless steels at low cutting speeds

Non-ferrous metals

CWK20

- ▲ Carbide, uncoated
- ▲ ISO | M10 | **K10** | **N10** | S10
- ▲ The wear-resistant carbide grade for machining aluminium and other non-ferrous metals

Steel

CCN20

- ▲ Carbide, TiAlN-coated
- ▲ ISO | **P20** | **M20** | **K20** | S20 | H20
- ▲ The all-round carbide grade for machining steels at low cutting speeds

CWN1525

- ▲ Carbide, TiN-coated
- ▲ ISO | **P25** | M25 | **K25** | **N25** | O25
- ▲ The universal carbide grade for machining steels and non-ferrous metals at low cutting speeds

Stainless steel

HCN2525

- ▲ Carbide, TiAlN-coated
- ▲ ISO | P25 | **M25** | K25 | N25 | S25 | H25
- ▲ The coated carbide grade for machining stainless steels at high cutting speeds
- ▲ Also suitable for exotic materials

8

Profile Type Description

Full profile

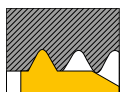

- ▲ Thread diameter must not be turned to final thread size
- ▲ a minimum infeed of 0.07 mm is necessary
- ▲ Insert can only be used only for a specific pitch

- Advantages:**
- ▲ High-quality thread
 - ▲ No burr formation
 - ▲ No rework
 - ▲ In part longer service life

Partial profile



- ▲ Core diameter must be premachined to the finished size
- ▲ A minimum infeed of 0.07 mm is required

- Advantages:**
- ▲ One threading insert can be used to machine several pitches
 - ▲ Threading insert can be used for any application
 - ▲ Reduced stock requirements

Multi-Tooth Thread Turning Insert



- ▲ Thread diameter must not be turned to final thread size
- ▲ a minimum infeed of 0.07 mm is necessary
- ▲ Insert can only be used only for a specific pitch

- Advantages:**
- ▲ Fewer passes required
 - ▲ Thread production in less time

Attention: ▲ Check there is sufficient thread run-out

Mini Thread Turning Insert



- ▲ From a min. core hole diameter of $\varnothing 6$ mm or $\varnothing 8$ mm

- Advantages:**
- ▲ Special cutting materials for low cutting speeds
 - ▲ 3 cutting edges for miniature applications