

Solid drilling and bore machining

- 1 HSS drilling
- 2 Solid carbide drilling
- 3 Indexable insert drilling
- 4 Reaming and Countersinking
- 5 Spindle Tooling

Threading

- 6 Taps and thread formers
- 7 Circular and Thread Milling
- 8 Thread turning

Turning

- 9 Turning Tools
- 10 Multifunctional Tools – EcoCut and FreeTurn
- 11 Grooving Tools
- 12 Miniature turning tools

Milling

- 13 HSS Milling Cutters
- 14 Solid Carbide milling cutters
- 15 Milling tools with indexable inserts

Clamping technology

- 16 Adaptors and Accessories
- 17 Workpiece clamping

- 18 Material examples

Table of contents

System overview	5
Toolfinder	4+5
Product programme	
UltraMini	6–34
MiniCut	35–53
UltraMini + MiniCut Hard Turning	10+36
SlotCut – Broaching	54–57
Technical Information	
Cutting Data	58–61
Broaching – Recommendations for Correct Use	62
Symbol explanation, coatings and thread types	63

WNT \ Performance

Premium quality tools for high performance.

The premium quality tools from the **WNT Performance** product line have been designed for specific applications and are distinguished by their outstanding performance. If you make high demands on the performance of your production and want to achieve the very best results, we recommend the Premium tools in this product line.

Toolfinder

EcoCut Mini

From Ø 2 mm

Inserts and tool holders can be found in
→ Chapter 10 Multifunctional Tools – EcoCut and FreeTurn

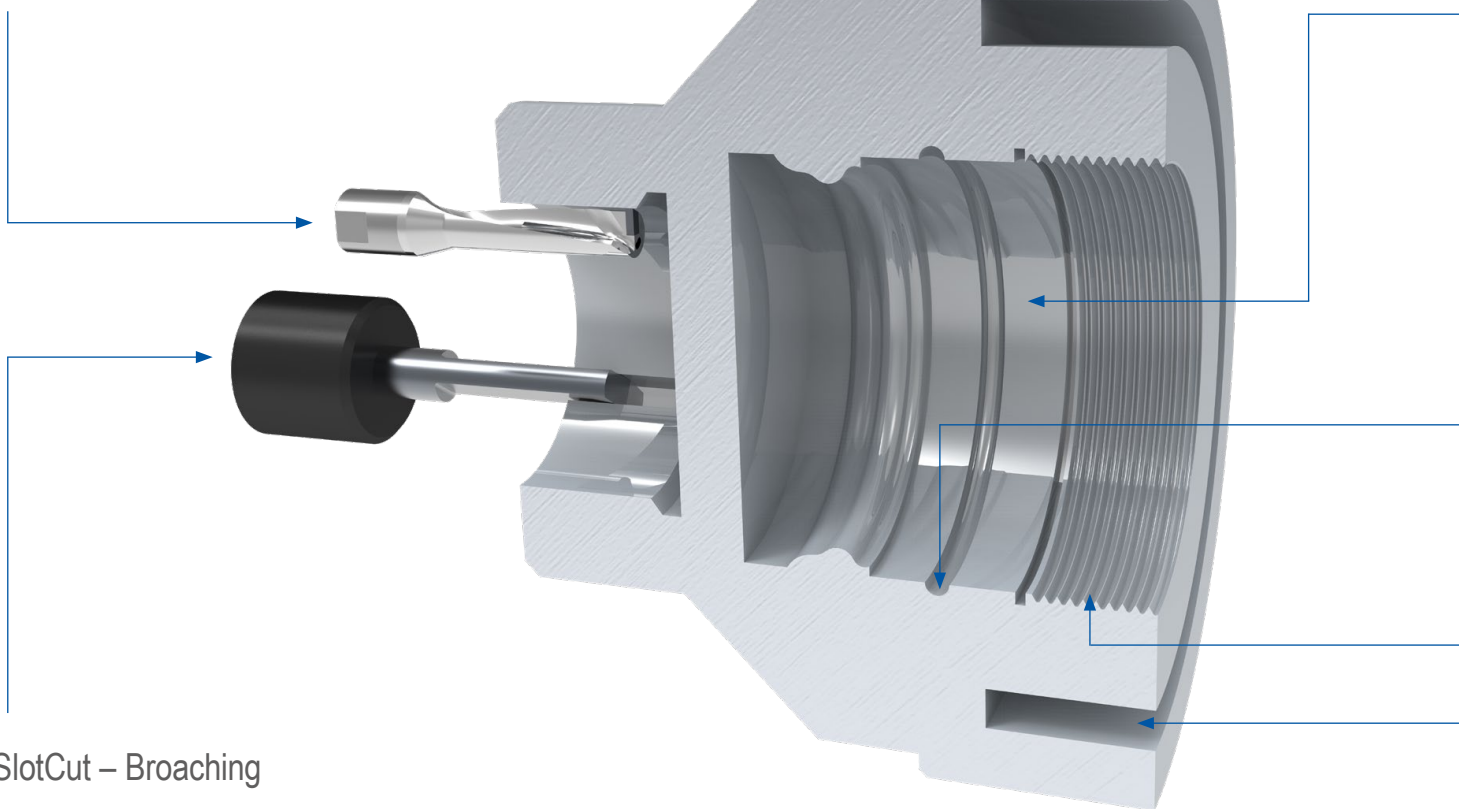

SlotCut – Broaching

Inserts + Holder DIN138 54–57

Symbol explanation



Internal machining



Internal grooving



Internal thread turning



Axial machining

System overview

UltraMini



- ▲ from Ø 0.5 mm
- ▲ flexible system
- ▲ ground inserts
- ▲ high repeatability
- ▲ coolant supply to the cutting edge

MiniCut



- ▲ from Ø 7.8 mm
- ▲ stable three-rib interface
- ▲ easy handling
- ▲ coolant supply to the cutting edge
- ▲ precise cutting edge position

SlotCut



- ▲ broaching directly on the machine
- ▲ usable from Ø 6 mm
- ▲ low machine load
- ▲ variety of tolerance classes

Hole diameter (mm)	UltraMini										MiniCut				
	≥ 0,5	≥ 2	≥ 2,4	≥ 2,8	≥ 3	≥ 4	≥ 5	≥ 6	≥ 8	≥ 16	≥ 8	≥ 9	≥ 11	≥ 14	≥ 16
Internal turning and profiling	6-9	6-9	6-9	6-9		6-9	6-9	6-9			35	35	35	35	35
Internal turning and profiling – hard turning		10		10		10	10	10			36		36	36	36
High-feed turning		11			11	11	11	11							
Internal turning				12		12	12				37	37	37	37	37
Back boring					13	13	13	13			38	38	38	38	
Turning and chamfering							14	14			38	38	38	38	
Pre-parting and chamfering						14	14	14			39	39	39	39	39
Internal Undercuts		18		18		18	18	18			42	42	42	42	42
Groove turning		15-17			15-17	15-17	15-17	15-17			40+41	40+41	40+41	40+41	40+41
Groove and profile turning						19	19	19			43	43	43	43	43
Internal thread turning			20-22			20-22	20-22	20-22			44-47	44-47	44-47	44-47	44-47
Axial grooving							23-28	23-28	23-28	23-28	48+49	48+49	48+49	48+49	48+49
suitable holder						31-34							50-53		
Sets						29+30							49		

UltraMini – Inserts for internal turning and profiling

▲ CDX = Maximum depth of cut when turning outwards

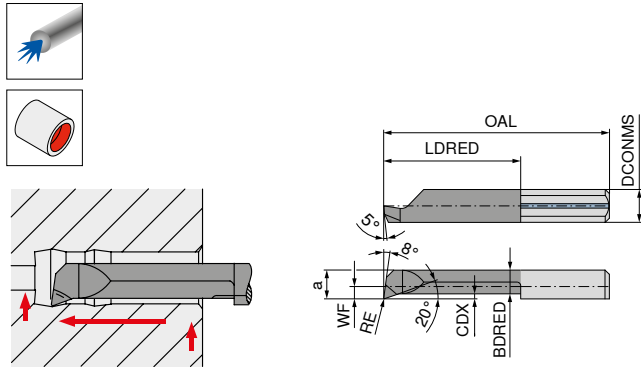

Illustrations show right-hand versions

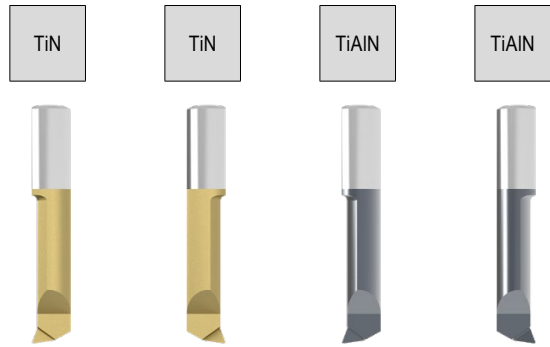

ISO designation	DCONMS ₁₆ mm	WF mm	DMIN mm	a mm	OAL mm	LDRED mm	CDX mm	BDRED mm	RE mm	Left-hand 73 005 ...		Right-hand 73 004 ...		Left-hand 73 005 ...		Right-hand 73 004 ...	
										£	Y5	£	Y5	£	Y5	£	Y5
R/L 050.05-2	4		0.5	0.4	20	2	0.03	0.32	0.02	78.36	500	78.36	500				
R/L 050.06-2	4		0.6	0.5	20	2	0.05	0.40	0.04	78.36	510	78.36	510				
R/L 050.06-3	4		0.6	0.5	20	3	0.05	0.40	0.04	80.91	511	80.91	511				
R/L 050.08-4	4		0.8	0.7	20	4	0.05	0.60	0.04					78.87	812	78.87	812
R/L 050.1-8	4		1.0	0.9	22	8	0.10	0.75	0.05					78.11	813	78.11	813
R/L 050.15-5	4		1.5	1.3	19	5	0.10	1.15	0.05	74.74	515	74.74	515				
R/L 050.15-10	4		1.5	1.3	24	10	0.10	1.15	0.05	75.45	516	75.45	516				
R/L 050.15-12	4		1.5	1.3	26	12	0.10	1.15	0.05					78.11	818	78.11	818
R/L 050.2-5	4		2.0	1.7	19	5	0.10	1.50	0.05	63.52	520	58.27	520				
R/L 050.2-10	4		2.0	1.7	24	10	0.10	1.50	0.05	64.25	521	63.52	521				
R/L 050.2-15	4		2.0	1.7	29	15	0.10	1.50	0.05	68.98	522	62.98	522				
R/L 050.3-10	4	0.6	2.8	2.6	24	10	0.20	2.30	0.10	68.98	531	66.98	531				
R/L 050.3-16	4	0.6	2.8	2.6	30	16	0.20	2.30	0.10	75.65	530	73.48	530				
R/L 050.3-20	4	0.6	2.8	2.6	34	20	0.20	2.30	0.10	71.85	532	73.37	532				
R/L 050.35-10	4	1.1	3.5	3.1	24	10	0.25	2.80	0.10					61.77	835	61.77	835
R/L 050.35-16	4	1.1	3.5	3.1	30	16	0.25	2.80	0.10					65.11	836	65.11	836
R/L 050.35-20	4	1.1	3.5	3.1	34	20	0.25	2.80	0.10					78.25	837	78.25	837
R/L 050.35-24	4	1.1	3.5	3.1	38	24	0.25	2.80	0.10					85.72	838	85.72	838
R/L 050.4-10	4	1.5	4.0	3.5	24	10	0.30	3.00	0.10	69.33	541	66.04	541	63.35	841	63.35	841
R/L 050.4-16	4	1.5	4.0	3.5	30	16	0.30	3.00	0.10	69.33	540	66.04	540	66.98	840	66.98	840
R/L 050.4-20	4	1.5	4.0	3.5	34	20	0.30	3.00	0.10	70.83	542	70.39	542	74.92	842	74.92	842
R/L 050.4-24	4	1.5	4.0	3.5	38	24	0.30	3.00	0.10	85.05	545	82.51	545	85.05	845	85.05	845
R/L 050.4-28	4	1.5	4.0	3.5	42	28	0.30	3.00	0.10	94.66	546	90.37	546	94.66	846	94.66	846
R/L 050.5-10	5	1.9	5.0	4.4	25	10	0.50	3.80	0.15	68.54	551	62.49	551	59.35	851	59.35	851
R/L 050.5-15	5	1.9	5.0	4.4	30	15	0.50	3.80	0.15	69.59	552	66.57	552	63.35	852	63.35	852
R/L 050.5-20	5	1.9	5.0	4.4	35	20	0.50	3.80	0.15	70.13	550	68.35	550	72.93	850	72.93	850
R/L 050.5-25	5	1.9	5.0	4.4	40	25	0.50	3.80	0.15	80.78	553	77.20	553	82.51	853	82.51	853
R/L 050.5-30	5	1.9	5.0	4.4	45	30	0.50	3.80	0.15	87.05	554	84.88	554	93.03	854	93.03	854
R/L 050.5-35	5	1.9	5.0	4.4	50	35	0.50	3.80	0.15	103.15	556	98.52	556	103.15	856	103.15	856
R/L 050.5-40	5	1.9	5.0	4.4	55	40	0.50	3.80	0.15					112.12	857	112.12	857
R/L 050.6-15	6	2.3	6.0	5.3	30	15	0.50	4.50	0.15	71.29	561	65.34	561	63.35	861	63.35	861
R/L 050.6-22	6	2.3	6.0	5.3	37	22	0.50	4.50	0.15	73.10	560	71.14	560	72.93	860	72.93	860
R/L 050.6-25	6	2.3	6.0	5.3	40	25	0.50	4.50	0.15	82.73	562	75.65	562	82.51	862	82.51	862
R/L 050.6-30	6	2.3	6.0	5.3	45	30	0.50	4.50	0.15	88.35	563	85.97	563	93.03	863	93.03	863
R/L 050.6-35	6	2.3	6.0	5.3	50	35	0.50	4.50	0.15	103.15	564	98.52	564	103.15	864	103.15	864
R/L 050.6-42	6	2.3	6.0	5.3	57	42	0.50	4.50	0.15	115.29	565	112.04	565	115.29	865	115.29	865
R/L 050.7-20	7	2.8	6.8	6.3	35	20	0.60	5.50	0.15	74.74	572	72.59	572	71.90	872	71.90	872
R/L 050.7-25	7	2.8	6.8	6.3	40	25	0.60	5.50	0.15	93.55	573	89.75	573	83.44	873	83.44	873
R/L 050.7-30	7	2.8	6.8	6.3	45	30	0.60	5.50	0.15	93.21	574	91.01	574	92.65	874	92.65	874
R/L 050.7-35	7	2.8	7.0	6.3	50	35	0.60	5.50	0.15	104.94	575	104.94	575	104.94	875	104.94	875
R/L 050.7-40	7	2.8	7.0	6.3	55	40	0.60	5.50	0.15	116.89	576	116.89	576	116.89	876	116.89	876
R/L 050.7-45	7	2.8	7.0	6.3	60	45	0.60	5.50	0.15	121.60	577	121.60	577	121.60	877	121.60	877
R/L 050.7-50	7	2.8	7.0	6.3	65	50	0.60	5.50	0.15	133.35	578	133.35	578	133.35	878	133.35	878
P											●		●		●		●
M											●		●		●		●
K											●		●		●		●
N											●		●		●		●
S											○		○		●		●
H											○		○		●		●
O											●		●		●		●

UltraMini – Inserts for internal turning and profiling

▲ CDX = Maximum depth of cut when turning outwards

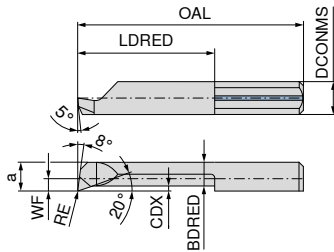
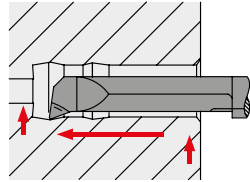

Left-hand

Right-hand

ISO designation	DCONMS _{h6} mm	WF mm	DMIN mm	a mm	OAL mm	LDRED mm	CDX mm	BDRED mm	RE mm	73 005 ...		73 004 ...	
										£ Y5		£ Y5	
R/L 050.2-5	4		2.0	1.7	19	5	0.1	1.5	0.05	50.78	020	50.78	020
R/L 050.2-10	4		2.0	1.7	24	10	0.1	1.5	0.05	53.22	021	53.22	021
R/L 050.2-15	4		2.0	1.7	29	15	0.1	1.5	0.05	56.83	022	56.83	022
R/L 050.3-10	4	0.6	2.8	2.6	24	10	0.2	2.3	0.10	53.77	031	53.77	031
R/L 050.3-16	4	0.6	2.8	2.6	30	16	0.2	2.3	0.10	61.96	030	61.96	030
R/L 050.3-20	4	0.6	2.8	2.6	34	20	0.2	2.3	0.10	63.50	032	63.50	032
R/L 050.4-10	4	1.5	4.0	3.5	24	10	0.3	3.0	0.10	53.92	041	53.92	041
R/L 050.4-16	4	1.5	4.0	3.5	30	16	0.3	3.0	0.10	55.93	040	55.93	040
R/L 050.4-20	4	1.5	4.0	3.5	34	20	0.3	3.0	0.10	59.35	042	58.61	042
R/L 050.5-10	5	1.9	5.0	4.4	25	10	0.5	3.8	0.15	54.32	051	54.32	051
R/L 050.5-15	5	1.9	5.0	4.4	30	15	0.5	3.8	0.15	57.17	052	57.17	052
R/L 050.5-20	5	1.9	5.0	4.4	35	20	0.5	3.8	0.15	59.18	050	59.18	050
R/L 050.5-25	5	1.9	5.0	4.4	40	25	0.5	3.8	0.15	68.54	053	68.54	053
R 050.5-30	5	1.9	5.0	4.4	45	30	0.5	3.8	0.05			75.19	054
L 050.5-30	5	1.9	5.0	4.4	45	30	0.5	3.8	0.15	74.20	054		
R/L 050.6-15	6	2.3	6.0	5.3	30	15	0.5	4.5	0.15	58.61	061	58.61	061
R/L 050.6-22	6	2.3	6.0	5.3	37	22	0.5	4.5	0.15	59.65	060	59.65	060
R/L 050.6-25	6	2.3	6.0	5.3	40	25	0.5	4.5	0.15	70.83	062	70.83	062
R/L 050.6-30	6	2.3	6.0	5.3	45	30	0.5	4.5	0.15	76.38	063	75.27	063
R/L 050.7-10	7	2.8	6.8	6.3	35	20	0.6	5.5	0.15	62.98	072	62.98	072
R/L 050.7-25	7	2.8	6.8	6.3	40	25	0.6	5.5	0.15	71.90	073	71.90	073
R/L 050.7-30	7	2.8	6.8	6.3	45	30	0.6	5.5	0.15	83.96	074	77.20	074

P		
M		
K		
N	○	○
S		
H		
O	●	●

→ v_c Page 59

UltraMini – Inserts for internal turning and profiling

▲ with corner radius ≤ 0.05 mm

▲ CDX = Maximum depth of cut when turning outwards

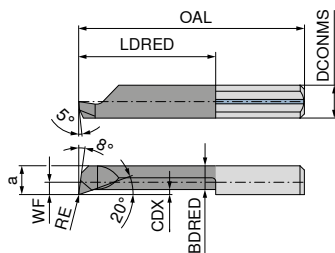
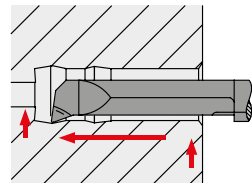

Illustrations show right-hand versions



ISO designation	DCONMS _{h6} mm	WF mm	DMIN mm	a mm	OAL mm	LDRED mm	CDX mm	BDRED mm	RE mm	Left-hand 73 021 ...		Right-hand 73 020 ...		Left-hand 73 023 ...		Right-hand 73 022 ...	
										£ Y5		£ Y5		£ Y5		£ Y5	
R/L 053.3-10	4	0.6	2.8	2.6	24	10	0.2	2.3	0.03	68.41	310	68.41	310				
R/L 053.3-16	4	0.6	2.8	2.6	30	16	0.2	2.3	0.03	72.02	316	72.02	316				
R/L 053.3-20	4	0.6	2.8	2.6	34	20	0.2	2.3	0.03	83.79	320	83.79	320				
R/L 053.4-10	4	1.5	4.0	3.5	24	10	0.3	3.0	0.03	68.41	410	68.41	410				
R/L 053.4-16	4	1.5	4.0	3.5	30	16	0.3	3.0	0.03	72.02	416	72.02	416				
R/L 053.4-20	4	1.5	4.0	3.5	34	20	0.3	3.0	0.03	81.46	420	81.46	420				
R/L 053.4-24	4	1.5	4.0	3.5	38	24	0.3	3.0	0.03	90.13	424	90.13	424				
R/L 053.4-28	4	1.5	4.0	3.5	42	28	0.3	3.0	0.03	98.00	428	98.00	428				
R/L 055.2-10	4		2.0	1.7	24	10	0.1	1.5	0.05					69.08	210	69.08	210
R/L 055.2-15	4		2.0	1.7	29	15	0.1	1.5	0.05					73.83	215	73.83	215
R/L 055.2-5	4		2.0	1.7	19	5	0.1	1.5	0.05					68.41	205	68.41	205
R/L 055.3-10	4	0.6	2.8	2.6	24	10	0.2	2.3	0.05					68.41	310	68.41	310
R/L 055.3-16	4	0.6	2.8	2.6	30	16	0.2	2.3	0.05					72.02	316	72.02	316
R/L 055.3-20	4	0.6	2.8	2.6	34	20	0.2	2.3	0.05					85.60	320	85.60	320
R/L 055.4-10	4	1.5	4.0	3.5	24	10	0.3	3.0	0.05					68.41	410	68.41	410
R/L 055.4-16	4	1.5	4.0	3.5	30	16	0.3	3.0	0.05					72.02	416	72.02	416
R/L 055.4-20	4	1.5	4.0	3.5	34	20	0.3	3.0	0.05					81.46	420	81.46	420
R/L 055.4-24	4	1.5	4.0	3.5	38	24	0.3	3.0	0.05					90.13	424	90.13	424
R/L 055.4-28	4	1.5	4.0	3.5	42	28	0.3	3.0	0.05					98.00	428	98.00	428
R/L 055.5-10	5	1.9	5.0	4.4	25	10	0.5	3.8	0.05					64.58	510	61.54	510
R/L 055.5-15	5	1.9	5.0	4.4	30	15	0.5	3.8	0.05					68.41	515	68.41	515
R/L 055.5-20	5	1.9	5.0	4.4	35	20	0.5	3.8	0.05					77.83	520	77.83	520
R/L 055.5-25	5	1.9	5.0	4.4	40	25	0.5	3.8	0.05					86.09	525	86.09	525
R/L 055.5-30	5	1.9	5.0	4.4	45	30	0.5	3.8	0.05					97.93	530	97.93	530
R/L 055.5-35	5	1.9	5.0	4.4	50	35	0.5	3.8	0.05					108.21	535	108.21	535
R/L 055.6-15	6	2.3	6.0	5.3	30	15	0.5	4.5	0.05					68.41	615	68.41	615
R/L 055.6-22	6	2.3	6.0	5.3	37	22	0.5	4.5	0.05					76.17	622	76.17	622
R/L 055.6-25	6	2.3	6.0	5.3	40	25	0.5	4.5	0.05					86.09	625	86.09	625
R/L 055.6-30	6	2.3	6.0	5.3	45	30	0.5	4.5	0.05					97.93	630	97.93	630
R/L 055.6-35	6	2.3	6.0	5.3	50	35	0.5	4.5	0.05					108.21	635	108.21	635
R/L 055.6-42	6	2.3	6.0	5.3	57	42	0.5	4.5	0.05					118.06	642	118.06	642
P											●		●		●		●
M											●		●		●		●
K											●		●		●		●
N											●		●		●		●
S											●		●		●		●
H											●		●		●		●
O											●		●		●		●

→ v_c Page 59

UltraMini – Inserts for internal turning and profiling

▲ with chip former

▲ CDX = Maximum depth of cut when turning outwards

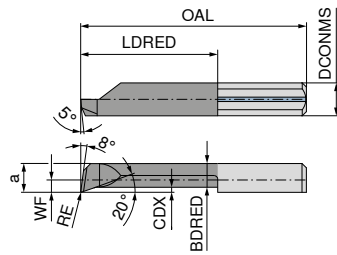
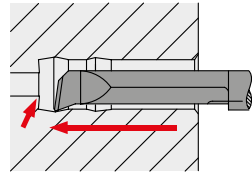

Illustrations show right-hand versions

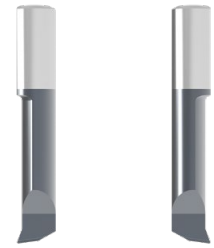

Left-hand Right-hand

ISO designation	DCONMS ₁₆ mm	WF mm	DMIN mm	a mm	OAL mm	LDRED mm	CDX mm	BDRED mm	RE mm	73 017 ...		73 016 ...	
										£		£	
R/L 050.4-10C	4	1.5	4	3.5	24	10	0.3	3.0	0.2	Y5	410	Y5	410
R/L 050.4-16C	4	1.5	4	3.5	30	16	0.3	3.0	0.2	63.35	416	63.35	416
R/L 050.4-20C	4	1.5	4	3.5	34	20	0.3	3.0	0.2	66.98	420	66.98	420
R/L 050.4-24C	4	1.5	4	3.5	38	24	0.3	3.0	0.2	74.92	424	74.92	424
R/L 050.4-28C	4	1.5	4	3.5	42	28	0.3	3.0	0.2	85.05	428	85.05	428
R/L 050.5-10C	5	1.9	5	4.4	25	10	0.5	3.8	0.2	94.66	428	94.66	428
R/L 050.5-15C	5	1.9	5	4.4	30	15	0.5	3.8	0.2	59.35	510	59.35	510
R/L 050.5-20C	5	1.9	5	4.4	35	20	0.5	3.8	0.2	63.35	515	63.35	515
R/L 050.5-25C	5	1.9	5	4.4	40	25	0.5	3.8	0.2	72.93	520	72.93	520
R/L 050.5-30C	5	1.9	5	4.4	45	30	0.5	3.8	0.2	82.51	525	82.51	525
R/L 050.5-35C	5	1.9	5	4.4	50	35	0.5	3.8	0.2	93.03	530	93.03	530
R/L 050.6-15C	6	2.3	6	5.3	30	15	0.5	4.5	0.2	103.15	535	103.15	535
R/L 050.6-22C	6	2.3	6	5.3	37	22	0.5	4.5	0.2	63.35	615	63.35	615
R/L 050.6-25C	6	2.3	6	5.3	40	25	0.5	4.5	0.2	72.93	622	72.93	622
R/L 050.6-30C	6	2.3	6	5.3	45	30	0.5	4.5	0.2	82.51	625	82.51	625
R/L 050.6-35C	6	2.3	6	5.3	50	35	0.5	4.5	0.2	93.03	630	93.03	630
R/L 050.6-42C	6	2.3	6	5.3	57	42	0.5	4.5	0.2	103.15	635	103.15	635
R/L 050.7-20C	7	2.8	7	6.3	35	20	0.6	5.5	0.2	115.29	642	115.29	642
R/L 050.7-25C	7	2.8	7	6.3	40	25	0.6	5.5	0.2	71.90	720	71.90	720
R/L 050.7-30C	7	2.8	7	6.3	45	30	0.6	5.5	0.2	83.44	725	83.44	725
R/L 050.7-35C	7	2.8	7	6.3	50	35	0.6	5.5	0.2	92.65	730	92.65	730
R/L 050.7-40C	7	2.8	7	6.3	55	40	0.6	5.5	0.2	104.94	735	104.94	735
R/L 050.7-45C	7	2.8	7	6.3	60	45	0.6	5.5	0.2	116.89	740	116.89	740
R/L 050.7-50C	7	2.8	7	6.3	65	50	0.6	5.5	0.2	121.60	745	121.60	745
										133.35	750	133.35	750
P											●		●
M											●		●
K											●		●
N											●		●
S											●		●
H											●		●
O											●		●

→ v. Page 59

UltraMini – Inserts for internal turning and profiling – hard turning

▲ 46 to 65 HRC

▲ CDX = Maximum depth of cut when turning outwards

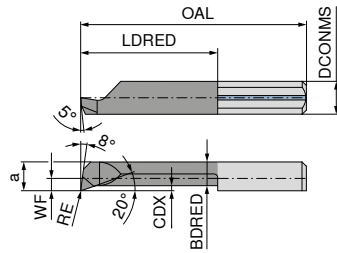
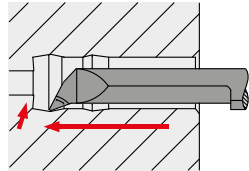

Illustrations show right-hand versions

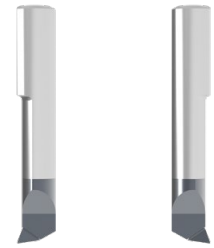

Left-hand Right-hand

ISO designation	DCONMS ₁₆ mm	WF mm	DMIN mm	a mm	OAL mm	LDRED mm	CDX mm	BDRED mm	RE mm	73 025 ...		73 024 ...	
										£	920	£	920
R/L 050.2-5	4		2.0	1.7	19	5	0.1	1.5	0.05	94.25	920	94.25	920
R/L 050.2-10	4		2.0	1.7	24	10	0.1	1.5	0.05	95.99	921	95.99	921
R/L 050.2-15	4		2.0	1.7	29	15	0.1	1.5	0.05	99.60	922	99.60	922
R/L 050.3-10	4	0.6	2.8	2.6	24	10	0.2	2.3	0.10	93.93	931	93.93	931
R/L 050.3-16	4	0.6	2.8	2.6	30	16	0.2	2.3	0.10	97.89	930	97.89	930
R/L 050.3-20	4	0.6	2.8	2.6	34	20	0.2	2.3	0.10	112.02	932	112.02	932
R/L 050.4-10	4	1.5	4.0	3.5	24	10	0.3	3.0	0.10	93.93	941	93.93	941
R/L 050.4-16	4	1.5	4.0	3.5	30	16	0.3	3.0	0.10	97.89	940	97.89	940
R/L 050.4-20	4	1.5	4.0	3.5	34	20	0.3	3.0	0.10	107.77	942	107.77	942
R/L 050.4-24	4	1.5	4.0	3.5	38	24	0.3	3.0	0.10	117.22	945	117.22	945
R/L 050.4-28	4	1.5	4.0	3.5	42	28	0.3	3.0	0.10	127.24	946	127.24	946
R/L 050.5-10	5	1.9	5.0	4.4	25	10	0.5	3.8	0.15	91.11	951	91.11	951
R/L 050.5-15	5	1.9	5.0	4.4	30	15	0.5	3.8	0.15	95.35	952	95.35	952
R/L 050.5-20	5	1.9	5.0	4.4	35	20	0.5	3.8	0.15	105.58	950	105.58	950
R/L 050.5-25	5	1.9	5.0	4.4	40	25	0.5	3.8	0.15	115.94	953	115.94	953
R/L 050.5-30	5	1.9	5.0	4.4	45	30	0.5	3.8	0.15	127.09	954	127.09	954
R/L 050.5-35	5	1.9	5.0	4.4	50	35	0.5	3.8	0.15	137.79	956	137.79	956
R/L 050.6-15	6	2.3	6.0	5.3	30	15	0.5	4.5	0.15	96.76	961	96.76	961
R/L 050.6-22	6	2.3	6.0	5.3	37	22	0.5	4.5	0.15	106.97	960	106.97	960
R/L 050.6-25	6	2.3	6.0	5.3	40	25	0.5	4.5	0.15	117.34	962	117.34	962
R/L 050.6-30	6	2.3	6.0	5.3	45	30	0.5	4.5	0.15	128.50	963	128.50	963
R/L 050.6-35	6	2.3	6.0	5.3	50	35	0.5	4.5	0.15	139.50	964	139.50	964
R/L 050.6-42	6	2.3	6.0	5.3	57	42	0.5	4.5	0.15	151.92	965	151.92	965
R/L 050.7-20	7	2.8	6.8	6.3	35	20	0.6	5.5	0.15	108.10	972	108.10	972
R/L 050.7-25	7	2.8	6.8	6.3	40	25	0.6	5.5	0.15	119.08	973	119.08	973
R/L 050.7-30	7	2.8	6.8	6.3	45	30	0.6	5.5	0.15	130.72	974	130.72	974
R/L 050.7-35	7	2.8	6.8	6.3	50	35	0.6	5.5	0.15	141.72	975	141.72	975
R/L 050.7-40	7	2.8	6.8	6.3	55	40	0.6	5.5	0.15	154.74	976	154.74	976
R/L 050.7-45	7	2.8	6.8	6.3	60	45	0.6	5.5	0.15	162.13	977	162.13	977
R/L 050.7-50	7	2.8	6.8	6.3	65	50	0.6	5.5	0.15	172.35	978	172.35	978
P											○		○
M											○		○
K											○		○
N											○		○
S											○		○
H											●		●
O											○		○

→ v_c Page 59

Machining with cooling is recommended.

UltraMini – Inserts for internal turning

- ▲ with chip former
- ▲ High-feed internal turning
- ▲ CDX = Maximum depth of cut when turning outwards

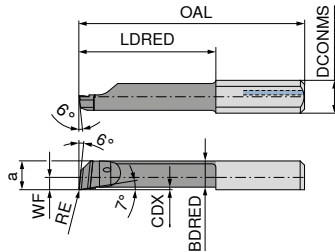
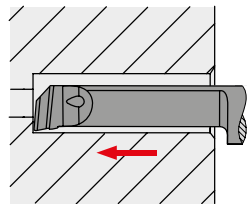

Illustrations show right-hand versions



Left-hand Right-hand

ISO designation	DCONMS ₁₆ mm	WF mm	DMIN mm	a mm	OAL mm	LDRED mm	CDX mm	BDRED mm	RE mm	73 001 ...		73 000 ...	
										£		£	
R/L X050.1-5	4		1.0	0.90	20	5	0.03	0.85	0.05	56.70	121	56.70	121
R/L X050.15-7	4		1.5	1.35	22	7	0.05	1.25	0.10	64.81	233	64.81	233
R/L X050.2-5	4		2.0	1.80	19	5	0.10	1.60	0.15	49.31	245	49.31	245
R/L X050.2-10	4		2.0	1.80	24	10	0.10	1.60	0.05	50.60	215	50.60	215
R/L X050.2-10	4		2.0	1.80	24	10	0.10	1.60	0.15	50.60	241	50.60	241
R/L X050.3-10	4	0.7	3.0	2.70	24	10	0.15	2.55	0.05	49.17	341	49.17	341
R/L X050.3-10	4	0.7	3.0	2.70	24	10	0.15	2.55	0.20	49.17	347	49.17	347
R/L X050.3-16	4	0.7	3.0	2.70	30	16	0.15	2.55	0.05	51.87	371	51.87	371
R/L X050.3-16	4	0.7	3.0	2.70	30	16	0.15	2.55	0.10	51.87	373	51.87	373
R/L X050.3-16	4	0.7	3.0	2.70	30	16	0.15	2.55	0.20	51.87	377	51.87	377
R/L X050.4-10	4	1.6	4.0	3.60	24	10	0.20	3.20	0.10	49.17	403	49.17	403
R/L X050.4-10	4	1.6	4.0	3.60	24	10	0.20	3.20	0.20	49.17	407	49.17	407
R/L X050.4-16	4	1.6	4.0	3.60	30	16	0.20	3.20	0.05	51.87	431	51.87	431
R/L X050.4-16	4	1.6	4.0	3.60	30	16	0.20	3.20	0.10	51.87	433	51.87	433
R/L X050.4-16	4	1.6	4.0	3.60	30	16	0.20	3.20	0.20	51.87	437	51.87	437
R/L X050.4-24	4	1.6	4.0	3.60	38	24	0.20	3.20	0.10	65.95	463	65.95	463
R/L X050.4-24	4	1.6	4.0	3.60	38	24	0.20	3.20	0.20	65.95	467	65.95	467
R/L X050.5-15	5	2.1	5.0	4.60	30	15	0.30	4.05	0.05	49.17	511	49.17	511
R/L X050.5-15	5	2.1	5.0	4.60	30	15	0.30	4.05	0.10	49.17	513	49.17	513
R/L X050.5-15	5	2.1	5.0	4.60	30	15	0.30	4.05	0.20	49.17	517	49.17	517
R/L X050.5-25	5	2.1	5.0	4.60	40	25	0.30	4.05	0.10	64.09	543	64.09	543
R/L X050.5-25	5	2.1	5.0	4.60	40	25	0.30	4.05	0.20	64.09	547	64.09	547
R/L X050.5-30	5	2.1	5.0	4.60	45	30	0.30	4.05	0.10	72.48	553	72.48	553
R/L X050.5-30	5	2.1	5.0	4.60	45	30	0.30	4.05	0.20	72.48	557	72.48	557
R/L X050.6-15	6	2.5	6.0	5.50	30	15	0.40	4.90	0.05	49.17	611	49.17	611
R/L X050.6-15	6	2.5	6.0	5.50	30	15	0.40	4.90	0.10	49.17	613	49.17	613
R/L X050.6-15	6	2.5	6.0	5.50	30	15	0.40	4.90	0.20	49.17	617	49.17	617
R/L X050.6-22	6	2.5	6.0	5.50	37	22	0.40	4.90	0.20	56.57	637	56.57	637
R/L X050.6-30	6	2.5	6.0	5.50	45	30	0.40	4.90	0.20	72.48	657	72.48	657
R/L X050.6-35	6	2.5	6.0	5.50	50	35	0.40	4.90	0.20	80.14	667	80.14	667
R/L X050.6-50	6	2.5	6.0	5.50	65	50	0.40	4.90	0.20	99.78	697	99.78	697
R/L X050.7-25	7	3.0	7.0	6.50	40	25	0.50	5.90	0.20	65.08	747	65.08	747
R/L X050.7-30	7	3.0	7.0	6.50	45	30	0.50	5.90	0.20	73.34	757	73.34	757

P	●	●
M	●	●
K	●	●
N	○	○
S	○	○
H	○	○
O	○	○

→ v_c Page 60+61

UltraMini – Inserts for internal turning

▲ CDX = Maximum depth of cut when turning outwards

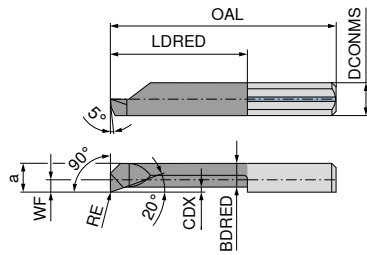
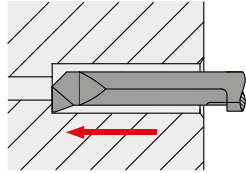

Illustrations show right-hand versions



Left-hand

Right-hand

ISO designation	DCONMS _{h6} mm	WF mm	DMIN mm	a mm	OAL mm	LDRED mm	CDX mm	BDRED mm	RE mm	73 015 ...		73 014 ...	
										£		£	
R/L 090.3-10	4	0.6	2.8	2.6	24	10	0.2	2.3	0.2	63.35	541	63.35	541
R/L 090.3-16	4	0.6	2.8	2.6	30	16	0.2	2.3	0.2	67.14	542	67.14	542
R/L 090.4-10	4	1.5	4.0	3.5	24	10	0.3	3.0	0.2	63.35	545	63.35	545
R/L 090.4-16	4	1.5	4.0	3.5	30	16	0.3	3.0	0.2	67.14	546	67.14	546
R/L 090.5-10	5	1.9	5.0	4.4	25	10	0.5	3.8	0.2	63.35	550	63.35	550
R/L 090.5-15	5	1.9	5.0	4.4	30	15	0.5	3.8	0.2	67.14	551	67.14	551
R/L 090.5-20	5	1.9	5.0	4.4	35	20	0.5	3.8	0.2	72.93	552	72.93	552

P		●	●
M		●	●
K		●	●
N		●	●
S		○	○
H		○	○
O		●	●

→ v_c Page 59

UltraMini – Inserts for back boring

▲ CDX = Maximum depth of cut when turning outwards

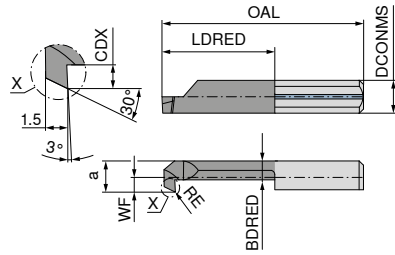
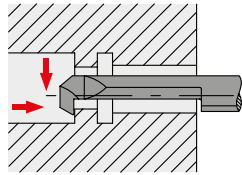

Illustrations show right-hand versions

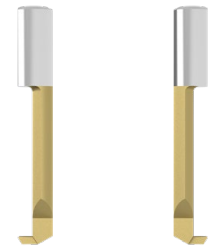

Left-hand Right-hand

ISO designation	DCONMS _{h6} mm	WF mm	DMIN mm	a mm	OAL mm	LDRED mm	CDX mm	BDRD mm	RE mm	73 013 ...		73 012 ...	
										£ Y5	542	£ Y5	542
R/L 080.0003-15	4	0.6	3	2.6	29	15	0.5	2.0	0.10	77.44	542	77.44	542
R/L 080.0003-20	4	0.6	3	2.6	34	20	0.5	2.0	0.10	92.31	544	92.31	544
R/L 080.0004-15	4	1.5	4	3.5	29	15	0.8	2.4	0.15	77.44	546	77.44	546
R/L 080.0004-25	4	1.5	4	3.5	39	25	0.8	2.4	0.15	86.82	548	86.82	548
R/L 080.0005-20	5	1.9	5	4.4	35	20	1.0	3.3	0.20	79.12	554	79.12	554
R/L 080.0005-30	5	1.9	5	4.4	45	30	1.0	3.3	0.20	82.19	558	82.19	558
R/L 080.0006-20	6	2.3	6	5.3	35	20	1.8	3.4	0.20	82.51	564	82.51	564
R/L 080.0006-30	6	2.3	6	5.3	45	30	1.8	3.4	0.20	98.79	568	98.79	568
R/L 080.0007-20	7	2.7	7	6.3	35	20	2.5	3.8	0.20	82.51	574	82.51	574
R/L 080.0007-30	7	2.7	7	6.3	45	30	2.5	3.8	0.20	98.79	578	98.79	578
P											●		●
M											●		●
K											●		●
N											●		●
S											○		○
H											○		○
O											●		●

→ v_c Page 59

UltraMini – Inserts for internal turning and chamfering

▲ CDX = Maximum depth of cut when turning outwards

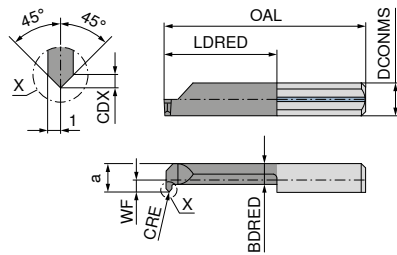
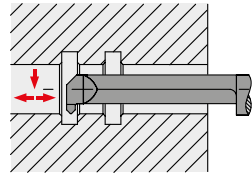
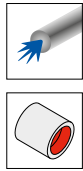

Illustrations show right-hand versions

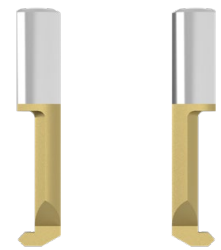

Left-hand Right-hand

ISO designation	DCONMS _{h6} mm	WF mm	DMIN mm	a mm	OAL mm	LDRED mm	CDX mm	BDRD mm	CRE mm
R/L 060.5-15	5	1.9	5.0	4.4	30	15	0.7	3.3	0.2
R/L 060.5-20	5	1.9	5.0	4.4	35	20	0.7	3.3	0.2
R/L 060.7-20	7	2.7	6.8	6.3	35	20	0.7	3.8	0.2

73 007 ...		73 006 ...	
£		£	
Y5		Y5	
64.25	551	59.70	551
66.74	550	66.45	550
74.92	570	69.33	570

P	●	●
M	●	●
K	●	●
N	●	●
S	○	○
H	○	○
O	●	●

→ v_c Page 59

UltraMini – Inserts for internal chamfering for subsequent parting off

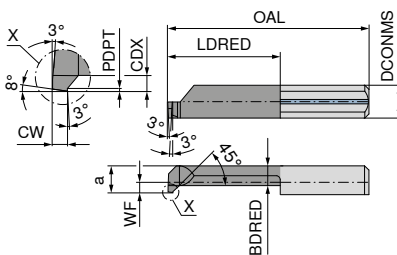
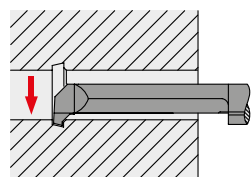
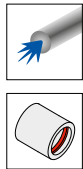

Illustrations show right-hand versions

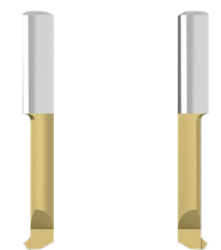

Left-hand Right-hand

ISO designation	DCONMS _{h6} mm	WF mm	DMIN mm	a mm	OAL mm	LDRED mm	CDX mm	BDRD mm	CW mm	PDPT mm
R/L 070.4-10	4	1.5	4	3.5	25	10	0.8	2.4	1	0.2
R/L 070.4-16	4	1.5	4	3.5	30	16	0.8	2.4	1	0.2
R/L 070.5-15	5	1.9	5	4.4	30	15	1.0	3.3	1	0.2
R/L 070.5-20	5	1.9	5	4.4	35	20	1.0	3.3	1	0.2
R/L 070.5-30	5	1.9	5	4.4	45	30	1.0	3.3	1	0.2
R/L 070.6-30	6	2.3	6	5.3	45	30	1.0	4.2	1	0.2
R/L 070.6-42	6	2.3	6	5.3	57	42	1.0	4.2	1	0.2

73 009 ...		73 008 ...	
£		£	
Y5		Y5	
66.51	410	66.51	410
68.49	416	68.49	416
65.69	551	65.69	551
69.33	550	69.33	550
92.59	530	92.59	530
92.59	630	92.59	630
108.31	642	108.31	642

P	●	●
M	●	●
K	●	●
N	●	●
S	○	○
H	○	○
O	●	●

→ v_c Page 59

UltraMini – Inserts for Internal Grooving

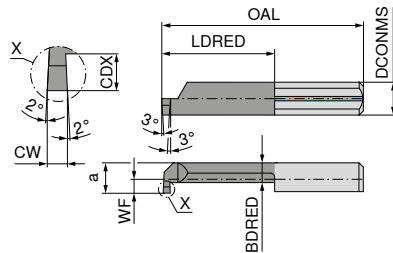
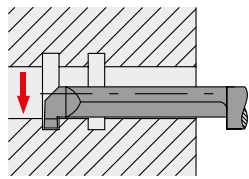
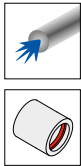

Illustrations show right-hand versions

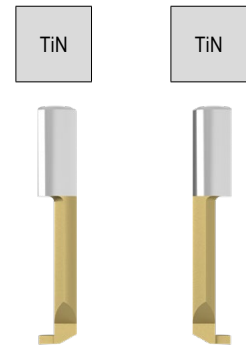

ISO designation	DCONMS _{h6} mm	WF mm	DMIN mm	a mm	OAL mm	LDRED mm	CDX mm	BDRED mm	CW mm	Left-hand 73 003 ...		Right-hand 73 002 ...	
										£	Y5	£	Y5
R/L 004.0100-10	4	1.5	4.0	3.5	24	10	0.8	2.4	1.0	60.18	540	58.83	540
R/L 004.0100-16	4	1.5	4.0	3.5	30	16	0.8	2.4	1.0	73.83	541	71.85	541
R/L 004.0100-20	4	1.5	4.0	3.5	34	20	0.8	2.4	1.0	79.65	542	77.44	542
R/L 005.0100-10	5	1.9	5.0	4.4	25	10	1.0	3.3	1.0	61.54	650	57.88	650
R/L 005.0150-10	5	1.9	5.0	4.4	25	10	1.0	3.3	1.5	61.54	654	59.92	654
R/L 005.0200-10	5	1.9	5.0	4.4	25	10	1.0	3.3	2.0	61.54	658	59.92	658
R/L 005.0100-15	5	1.9	5.0	4.4	30	15	1.0	3.3	1.0	71.14	651	67.80	651
R/L 005.0150-15	5	1.9	5.0	4.4	30	15	1.0	3.3	1.5	71.14	655	67.80	655
R/L 005.0200-15	5	1.9	5.0	4.4	30	15	1.0	3.3	2.0	71.14	659	67.80	659
R/L 005.0100-20	5	1.9	5.0	4.4	35	20	1.0	3.3	1.0	77.20	551	76.76	551
R/L 005.0150-20	5	1.9	5.0	4.4	35	20	1.0	3.3	1.5	77.20	552	76.76	552
R/L 005.0200-20	5	1.9	5.0	4.4	35	20	1.0	3.3	2.0	77.20	553	76.76	553
R/L 005.0100-25	5	1.9	5.0	4.4	40	25	1.0	3.3	1.0	87.41	652	85.05	652
R/L 005.0150-25	5	1.9	5.0	4.4	40	25	1.0	3.3	1.5	87.41	656	85.05	656
R/L 005.0200-25	5	1.9	5.0	4.4	40	25	1.0	3.3	2.0	87.95	750	85.60	750
R/L 005.0100-30	5	1.9	5.0	4.4	45	30	1.0	3.3	1.0	97.36	653	94.66	653
R/L 005.0150-30	5	1.9	5.0	4.4	45	30	1.0	3.3	1.5	97.36	657	94.66	657
R/L 005.0200-30	5	1.9	5.0	4.4	45	30	1.0	3.3	2.0	97.93	751	95.38	751
R/L 005.0100-35	5	1.9	5.0	4.4	50	35	1.0	3.3	1.0	108.21	680	103.32	680
R/L 006.0100-10	6	2.3	6.0	5.3	25	10	1.8	3.4	1.0	60.72	660	58.95	660
R/L 006.0150-10	6	2.3	6.0	5.3	25	10	1.8	3.4	1.5	60.72	664	56.45	664
R/L 006.0200-10	6	2.3	6.0	5.3	25	10	1.8	3.4	2.0	60.72	668	58.95	668
R/L 006.0100-15	6	2.3	6.0	5.3	30	15	1.8	3.4	1.0	70.13	661	68.35	661
R/L 006.0150-15	6	2.3	6.0	5.3	30	15	1.8	3.4	1.5	70.13	665	68.35	665
R/L 006.0200-15	6	2.3	6.0	5.3	30	15	1.8	3.4	2.0	70.13	669	68.35	669
R/L 006.0100-22	6	2.3	6.0	5.3	37	22	1.8	3.4	1.0	77.94	561	77.30	561
R/L 006.0150-22	6	2.3	6.0	5.3	37	22	1.8	3.4	1.5	77.94	562	77.30	562
R/L 006.0200-22	6	2.3	6.0	5.3	37	22	1.8	3.4	2.0	77.94	563	77.30	563
R/L 006.0100-25	6	2.3	6.0	5.3	40	25	1.8	3.4	1.0	87.95	662	85.60	662
R/L 006.0150-25	6	2.3	6.0	5.3	40	25	1.8	3.4	1.5	87.95	666	85.60	666
R/L 006.0200-25	6	2.3	6.0	5.3	40	25	1.8	3.4	2.0	87.95	760	85.60	760
R/L 006.0100-30	6	2.3	6.0	5.3	45	30	1.8	3.4	1.0	97.93	663	95.38	663
R/L 006.0150-30	6	2.3	6.0	5.3	45	30	1.8	3.4	1.5	97.93	667	95.38	667
R/L 006.0200-30	6	2.3	6.0	5.3	45	30	1.8	3.4	2.0	97.93	761	95.38	761
R/L 006.0100-35	6	2.3	6.0	5.3	50	35	1.8	3.4	1.0	108.21	682	103.32	682
R/L 006.0150-35	6	2.3	6.0	5.3	50	35	1.8	3.4	1.5	108.21	684	103.32	684
R/L 006.0100-42	6	2.3	6.0	5.3	57	42	1.8	3.4	1.0	119.43	685	116.01	685
R/L 007.0100-10	7	2.7	6.8	6.3	25	10	2.5	3.8	1.0	61.26	570	59.92	570
R/L 007.0150-10	7	2.7	6.8	6.3	25	10	2.5	3.8	1.5	61.26	575	59.92	575
R/L 007.0200-10	7	2.7	6.8	6.3	25	10	2.5	3.8	2.0	61.26	670	59.92	670
R/L 007.0100-15	7	2.7	6.8	6.3	30	15	2.5	3.8	1.0	70.83	571	69.08	571
R/L 007.0150-15	7	2.7	6.8	6.3	30	15	2.5	3.8	1.5	70.83	576	69.08	576
R/L 007.0200-15	7	2.7	6.8	6.3	30	15	2.5	3.8	2.0	70.83	671	66.06	671
R/L 007.0100-22	7	2.7	6.8	6.3	37	22	2.5	3.8	1.0	79.71	572	78.90	572
R/L 007.0150-22	7	2.7	6.8	6.3	37	22	2.5	3.8	1.5	79.71	577	78.90	577
R/L 007.0200-22	7	2.7	6.8	6.3	37	22	2.5	3.8	2.0	79.71	672	78.90	672
R/L 007.0100-25	7	2.7	6.8	6.3	40	25	2.5	3.8	1.0	88.87	573	86.51	573
R/L 007.0150-25	7	2.7	6.8	6.3	40	25	2.5	3.8	1.5	88.87	578	86.51	578
R/L 007.0200-25	7	2.7	6.8	6.3	40	25	2.5	3.8	2.0	88.87	673	85.25	673
R/L 007.0100-30	7	2.7	6.8	6.3	45	30	2.5	3.8	1.0	98.00	574	97.00	574
R/L 007.0150-30	7	2.7	6.8	6.3	45	30	2.5	3.8	1.5	98.00	579	93.89	579
R/L 007.0200-30	7	2.7	6.8	6.3	45	30	2.5	3.8	2.0	98.00	674	91.01	674
R/L 007.0100-35	7	2.7	7.0	6.3	50	35	2.5	3.8	1.0	109.29	688	106.23	688
R/L 007.0150-35	7	2.7	7.0	6.3	50	35	2.5	3.8	1.5	109.29	690	106.23	690
R/L 007.0200-35	7	2.7	7.0	6.3	50	35	2.5	3.8	2.0	109.29	692	106.23	692
R/L 007.0100-40	7	2.7	7.0	6.3	55	40	2.5	3.8	1.0	121.24	700	117.80	700
R/L 007.0150-40	7	2.7	7.0	6.3	55	40	2.5	3.8	1.5	121.24	702	117.80	702
R/L 007.0100-45	7	2.7	7.0	6.3	60	45	2.5	3.8	1.0	131.56	712	127.96	712
R/L 007.0100-50	7	2.7	7.0	6.3	65	50	2.5	3.8	1.0	140.97	714	136.81	714

P	●	●
M	●	●
K	●	●
N	●	●
S	○	○
H	○	○
O	●	●

UltraMini – Inserts for Internal Grooving

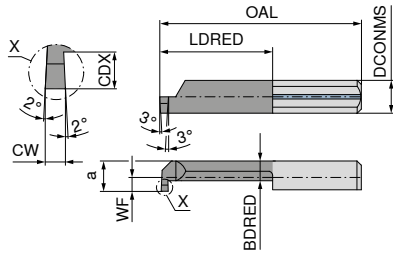
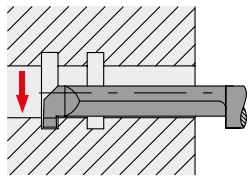

Illustrations show right-hand versions

TiAlN

TiAlN



Left-hand

Right-hand

ISO designation	DCONMS ^{h6} mm	WF mm	DMIN mm	a mm	OAL mm	LDRED mm	CDX mm	BDFRED mm	CW mm	73 003 ...		73 002 ...	
										£		£	
R/L 002.0050-5	4		2	1.8	19	5	0.4	1.2	0.5	75.65	820	75.65	820
R/L 002.0050-10	4		2	1.8	24	10	0.4	1.2	0.5	76.17	821	76.17	821
R/L 002.0050-15	4		2	1.8	29	15	0.4	1.2	0.5	83.79	822	83.79	822
R/L 003.0070-5	4	0.7	3	2.7	19	5	0.6	1.9	0.7	70.13	830	70.13	830
R/L 003.0070-10	4	0.7	3	2.7	24	10	0.6	1.9	0.7	80.91	831	80.91	831
R/L 003.0070-16	4	0.7	3	2.7	30	16	0.6	1.9	0.7	90.13	832	90.13	832
P											●		●
M											●		●
K											●		●
N											●		●
S											●		●
H											●		●
O											●		●

→ v_c Page 59

UltraMini – Inserts for Internal Grooving

▲ with corner radius

▲ CDX = Maximum depth of cut when turning outwards

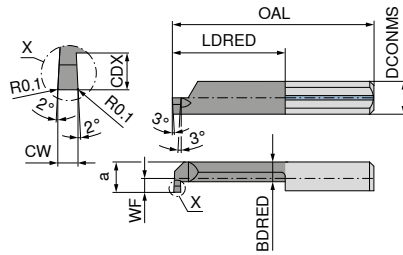
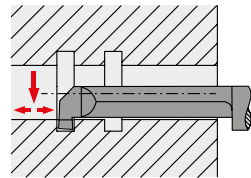
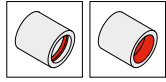

Illustrations show right-hand versions

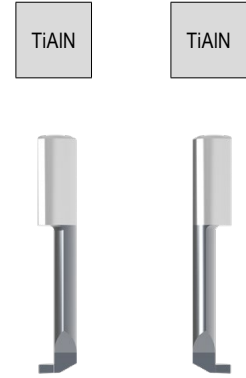

Left-hand Right-hand

ISO designation	DCONMS _{ns} mm	WF mm	DMIN mm	a mm	OAL mm	LDRED mm	CDX mm	BDRED mm	CW mm	73 203 ...		73 202 ...	
										£	800	£	800
R/L 004M0100-10	4	1.5	4.0	3.5	24	10	0.8	2.4	1.0	64.67	800	64.67	800
R/L 004M0100-16	4	1.5	4.0	3.5	30	16	0.8	2.4	1.0	73.83	802	73.83	802
R/L 004M0100-20	4	1.5	4.0	3.5	34	20	0.8	2.4	1.0	81.32	804	81.32	804
R/L 005M0100-10	5	1.9	5.0	4.4	25	10	1.0	3.3	1.0	61.04	806	61.04	806
R/L 005M0150-10	5	1.9	5.0	4.4	25	10	1.0	3.3	1.5	61.04	816	61.04	816
R/L 005M0200-10	5	1.9	5.0	4.4	25	10	1.0	3.3	2.0	61.04	826	61.04	826
R/L 005M0100-15	5	1.9	5.0	4.4	30	15	1.0	3.3	1.0	69.98	808	69.98	808
R/L 005M0150-15	5	1.9	5.0	4.4	30	15	1.0	3.3	1.5	69.98	818	69.98	818
R/L 005M0200-15	5	1.9	5.0	4.4	30	15	1.0	3.3	2.0	69.98	828	69.98	828
R/L 005M0100-20	5	1.9	5.0	4.4	35	20	1.0	3.3	1.0	78.19	810	78.19	810
R/L 005M0150-20	5	1.9	5.0	4.4	35	20	1.0	3.3	1.5	78.19	820	78.19	820
R/L 005M0200-20	5	1.9	5.0	4.4	35	20	1.0	3.3	2.0	78.19	830	78.19	830
R/L 005M0100-25	5	1.9	5.0	4.4	40	25	1.0	3.3	1.0	84.92	812	84.92	812
R/L 005M0150-25	5	1.9	5.0	4.4	40	25	1.0	3.3	1.5	84.92	822	84.92	822
R/L 005M0200-25	5	1.9	5.0	4.4	40	25	1.0	3.3	2.0	84.92	832	84.92	832
R/L 005M0100-30	5	1.9	5.0	4.4	45	30	1.0	3.3	1.0	94.12	814	94.12	814
R/L 005M0150-30	5	1.9	5.0	4.4	45	30	1.0	3.3	1.5	94.12	824	94.12	824
R/L 005M0200-30	5	1.9	5.0	4.4	45	30	1.0	3.3	2.0	94.12	834	94.12	834
R/L 006M0100-10	6	2.3	6.0	5.3	25	10	1.8	3.4	1.0	61.04	836	61.04	836
R/L 006M0150-10	6	2.3	6.0	5.3	25	10	1.8	3.4	1.5	61.04	846	61.04	846
R/L 006M0200-10	6	2.3	6.0	5.3	25	10	1.8	3.4	2.0	61.04	856	61.04	856
R/L 006M0100-15	6	2.3	6.0	5.3	30	15	1.8	3.4	1.0	69.98	838	69.98	838
R/L 006M0150-15	6	2.3	6.0	5.3	30	15	1.8	3.4	1.5	69.98	848	69.98	848
R/L 006M0200-15	6	2.3	6.0	5.3	30	15	1.8	3.4	2.0	69.98	858	69.98	858
R/L 006M0100-20	6	2.3	6.0	5.3	35	22	1.8	3.4	1.0	78.19	840	78.19	840
R/L 006M0150-20	6	2.3	6.0	5.3	37	22	1.8	3.4	1.5	78.19	850	78.19	850
R/L 006M0200-20	6	2.3	6.0	5.3	37	22	1.8	3.4	2.0	78.19	860	78.19	860
R/L 006M0100-25	6	2.3	6.0	5.3	40	25	1.8	3.4	1.0	84.92	842	84.92	842
R/L 006M0150-25	6	2.3	6.0	5.3	40	25	1.8	3.4	1.5	84.92	852	84.92	852
R/L 006M0200-25	6	2.3	6.0	5.3	40	25	1.8	3.4	2.0	84.92	862	84.92	862
R/L 006M0100-30	6	2.3	6.0	5.3	45	30	1.8	3.4	1.0	94.12	844	94.12	844
R/L 006M0150-30	6	2.3	6.0	5.3	45	30	1.8	3.4	1.5	94.12	854	94.12	854
R/L 006M0200-30	6	2.3	6.0	5.3	45	30	1.8	3.4	2.0	94.12	864	94.12	864
R/L 007M0100-10	7	2.7	6.8	6.3	25	10	2.5	3.7	1.0	61.04	866	61.04	866
R/L 007M0150-10	7	2.7	6.8	6.3	25	10	2.5	3.7	1.5	61.04	876	61.04	876
R/L 007M0200-10	7	2.7	6.8	6.3	25	10	2.5	3.7	2.0	61.04	886	61.04	886
R/L 007M0100-15	7	2.7	6.8	6.3	30	15	2.5	3.7	1.0	69.98	868	69.98	868
R/L 007M0150-15	7	2.7	6.8	6.3	30	15	2.5	3.7	1.5	69.98	878	69.98	878
R/L 007M0200-15	7	2.7	6.8	6.3	30	15	2.5	3.7	2.0	69.98	888	69.98	888
R/L 007M0100-22	7	2.7	6.8	6.3	37	22	2.5	3.7	1.0	78.19	870	78.19	870
R/L 007M0150-22	7	2.7	6.8	6.3	37	22	2.5	3.7	1.5	78.19	880	78.19	880
R/L 007M0200-22	7	2.7	6.8	6.3	37	22	2.5	3.7	2.0	78.19	890	78.19	890
R/L 007M0100-25	7	2.7	6.8	6.3	40	25	2.5	3.7	1.0	84.92	872	84.92	872
R/L 007M0150-25	7	2.7	6.8	6.3	40	25	2.5	3.7	1.5	84.92	882	84.92	882
R/L 007M0200-25	7	2.7	6.8	6.3	40	25	2.5	3.7	2.0	84.92	892	84.92	892
R/L 007M0100-30	7	2.7	6.8	6.3	45	30	2.5	3.7	1.0	94.82	874	94.82	874
R/L 007M0150-30	7	2.7	6.8	6.3	45	30	2.5	3.7	1.5	94.82	884	94.82	884
R/L 007M0200-30	7	2.7	6.8	6.3	45	30	2.5	3.7	2.0	94.82	894	94.82	894

P	•	•
M	•	•
K	•	•
N	•	•
S	•	•
H	•	•
O	•	•

UltraMini – Inserts for internal undercuts

▲ CDX = Maximum depth of cut when turning outwards

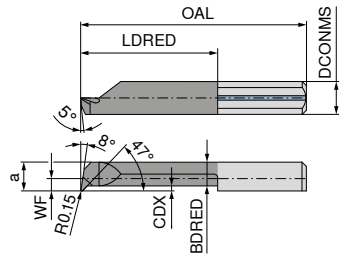
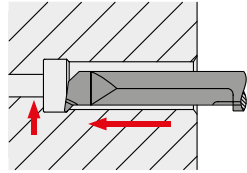
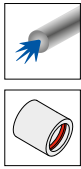

Illustrations show right-hand versions

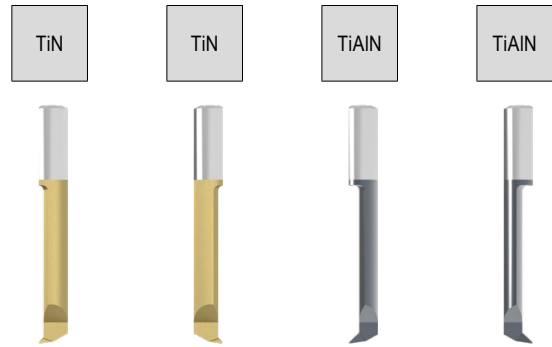

ISO designation	DCONMS _{ns} mm	WF mm	DMIN mm	a mm	OAL mm	LDRED mm	CDX mm	BDRED mm	Left-hand		Right-hand		Left-hand		Right-hand	
									£		£		£		£	
R/L 047.2-10	4		2.0	1.7	24	10	0.4	1.2	Y5		Y5		71.22	221	71.22	221
R/L 047.3-15	4	0.6	2.8	2.6	29	15	0.6	1.9					74.14	231	74.14	231
R/L 047.4-10	4	1.5	4.0	3.5	24	10	0.6	2.8					67.89	241	67.89	241
R/L 047.T4-20	4	1.5	4.0	3.5	34	20	0.6	2.8					79.63	242	79.63	242
R/L 047.4-20	4	1.5	4.0	3.5	34	20	0.3	3.0	76.56	542	75.47	542				
R/L 047.5-15	5	1.9	5.0	4.4	30	15	0.8	3.5					76.41	251	76.41	251
R/L 047.T5-25	5	1.9	5.0	4.4	40	25	0.8	3.5					80.83	252	80.83	252
R/L 047.5-25	5	1.9	5.0	4.4	40	25	0.5	3.8	76.17	552	76.17	552				
R/L 047.T6-22	6	2.3	6.0	5.3	37	22	1.8	3.4					78.25	262	78.25	262
R/L 047.T6-30	6	2.3	6.0	5.3	45	30	1.8	3.4					104.18	263	82.69	263
R/L 047.6-30	6	2.3	6.0	5.3	45	30	0.5	4.5	77.94	562	79.12	562				
P										●		●		●		●
M										●		●		●		●
K										●		●		●		●
N										●		●		●		●
S										○		○		●		●
H										○		○		●		●
O										●		●		●		●

→ v_c Page 59

UltraMini – Inserts for internal grooving and turning

▲ CDX = Maximum depth of cut when turning outwards

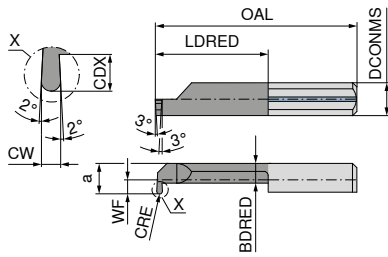
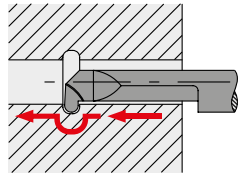
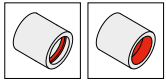

Illustrations show right-hand versions

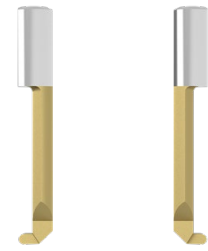

Left-hand Right-hand

ISO designation	DCONMS _{HS} mm	WF mm	DMIN mm	a mm	OAL mm	LDRED mm	CDX mm	BDRED mm	CW mm	CRE mm	73 019 ...		73 018 ...	
											£ Y5	564	£ Y5	564
R/L 006-0.75-25	6	2.3	6.0	5.3	40	25	1.8	3.4	1.5	0.75	80.35	564	80.35	564
R/L 004-0.50-16	4	1.5	4.0	3.5	30	16	0.8	2.4	1.0	0.50	74.36	541	71.14	541
R/L 005-0.50-20	5	1.9	5.0	4.4	35	20	1.0	3.3	1.0	0.50	78.55	552	78.55	552
R/L 005-0.75-20	5	1.9	5.0	4.4	35	20	1.0	3.3	1.5	0.75	78.55	554	78.55	554
R/L 005-1.00-20	5	1.9	5.0	4.4	35	20	1.0	3.3	2.0	1.00	78.55	556	78.55	556
R/L 006-0.50-25	6	2.3	6.0	5.3	40	25	1.8	3.4	1.0	0.50	80.35	562	80.35	562
R/L 006-1.00-25	6	2.3	6.0	5.3	40	25	1.8	3.4	2.0	1.00	80.35	566	79.12	566
R/L 007-0.50-30	7	2.7	6.8	6.3	45	30	2.5	3.8	1.0	0.50	82.88	572	79.01	572
R/L 007-0.75-30	7	2.7	6.8	6.3	45	30	2.5	3.8	1.5	0.75	82.88	574	82.88	574
R/L 007-1.00-30	7	2.7	6.8	6.3	45	30	2.5	3.8	2.0	1.00	82.88	576	82.88	576
P												●		●
M												●		●
K												●		●
N												●		●
S												○		○
H												○		○
O												●		●

→ v_c Page 59

UltraMini – Inserts for internal threading (Partial profile)

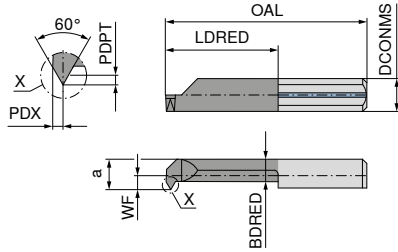
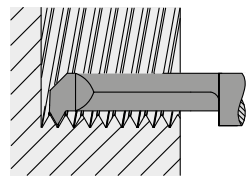

Illustrations show right-hand versions

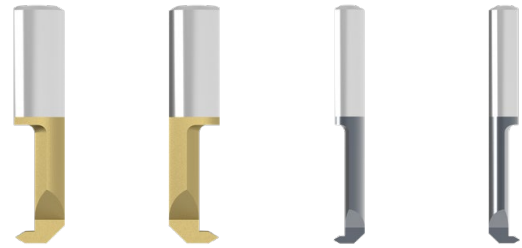

ISO designation	DCONMS _{ns} mm	TP mm	WF mm	DMIN mm	a mm	OAL mm	LDRED mm	BDRED mm	PDPT mm	PDX mm
R/L 003.0105-8	4	0,5 - 0,7	0.30	2.4	2.3	22	8	1.8	0.27	0.33
R/L 004.0408-15	4	0,8 - 1,0	1.75	4.0	3.5	30	15	2.4	0.43	0.45
R/L 005.0510-20	5	1,0 - 1,25	1.90	4.8	4.4	35	20	3.3	0.55	0.55
R/L 005.0510-15	5	1,0 - 1,25	1.90	4.8	4.4	30	15	3.3	0.55	0.55
R/L 006.0612-22	6	1,25 - 1,5	2.30	6.0	5.3	37	22	3.4	0.68	0.65
R/L 006.0612-15	6	1,25 - 1,5	2.30	6.0	5.3	30	15	3.4	0.68	0.65
R/L 006.0815-15	6	1,5 - 1,75	2.30	6.0	5.3	30	15	3.4	0.81	0.75
R/L 006.0815-22	6	1,5 - 1,75	2.30	6.0	5.3	37	22	3.4	0.81	0.75
R/L 007.0815-15	7	1,5 - 1,75	2.70	7.0	6.3	30	15	3.8	0.81	0.75

Left-hand 73 101 ...		Right-hand 73 100 ...		Left-hand 73 101 ...		Right-hand 73 100 ...	
£		£		£		£	
Y5		Y5		Y5	551	Y5	551
				71.98	552	71.98	552
				75.05		75.05	
69.40	544	69.13	544				
68.46	545	66.35	545				
70.33	546	68.63	546				
67.10	547	66.35	547				
68.46	549	67.22	549				
70.33	548	68.63	548				
68.04	550	68.63	550				

P	•	•	•	•
M	•	•	•	•
K	•	•	•	•
N	•	•	•	•
S	○	○	•	•
H	○	○	•	•
O	•	•	•	•

→ v_c Page 59

UltraMini – Inserts for Internal thread turning (Full profile)

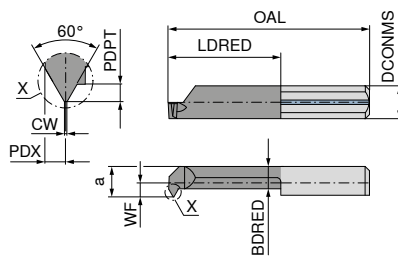
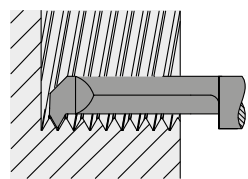

Illustrations show right-hand versions

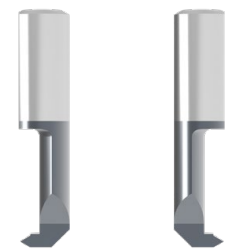

ISO designation	DCONMS _{ns} mm	TP mm	WF mm	DMIN mm	a mm	OAL mm	LDRED mm	BDRED mm	PDPT mm	PDX mm	CW mm
R/L 105.0408-15	5	0.80	1.9	4.8	4.4	30	15	3.3	0.43	0.50	0.10
R/L 105.510-15	5	1.00	1.9	4.8	4.4	30	15	3.3	0.54	0.55	0.12
R/L 106.612-15	6	1.25	2.3	6.0	5.3	30	15	3.4	0.67	0.65	0.15
R/L 106.815-15	6	1.50	2.3	6.0	5.3	30	15	3.4	0.81	0.75	0.18
R/L 106.815-15	7	1.50	2.7	7.0	6.3	30	15	3.8	0.81	0.75	0.18

Left-hand 73 209 ...		Right-hand 73 208 ...	
£		£	
Y5		Y5	
77.80	799	77.80	799
71.90	800	71.90	800
71.90	802	71.90	802
71.90	804	71.90	804
71.90	806	71.90	806

P	•	•	•	•
M	•	•	•	•
K	•	•	•	•
N	•	•	•	•
S	•	•	•	•
H	•	•	•	•
O	•	•	•	•

→ v_c Page 59

UltraMini – Inserts for internal thread turning (Partial profile)

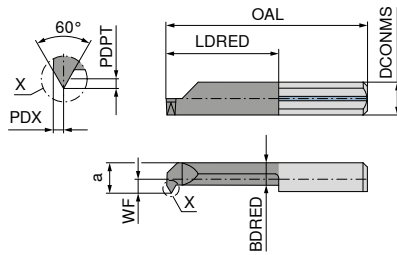
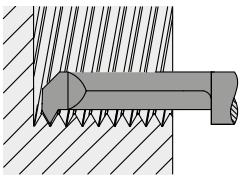

Illustrations show right-hand versions

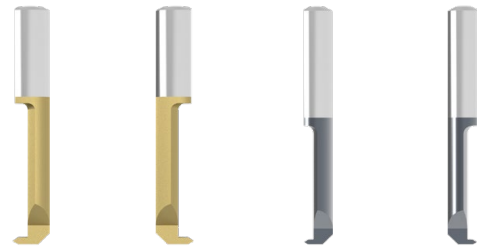

ISO designation	DCONMS _{hg} mm	TP mm	WF mm	DMIN mm	a mm	OAL mm	LDRED mm	BDRED mm	PDPT mm	PDX mm	Left-hand 73 103 ...		Right-hand 73 102 ...		Left-hand 73 103 ...		Right-hand 73 102 ...	
											£		£		£		£	
R/L 004.0205-15	4	0,5 - 0,75	1.5	4.0	3.5	30	15	2.4	0.27	0.35	70.90	510	70.90	510				
R/L 004.0105-10	4	0,5 - 0,75	1.0	3.2	3.0	24	10	2.3	0.27	0.44					70.93	509	70.93	509
R/L 005.0205-15	5	0,5 - 0,75	1.9	5.0	4.4	30	15	3.3	0.27	0.35	68.46	539	68.46	539				
R/L 005.0205-20	5	0,5 - 0,75	1.9	5.0	4.4	35	20	3.3	0.27	0.35	69.40	540	69.40	540				
L 005.0407-15	5	0,75 - 1,0	1.9	5.0	4.4	30	15	3.3	0.40	0.45	68.46	541						
R 005.0407-15	5	0,75 - 1,0	1.9	5.0	4.4	30	15	3.3	0.40	0.45			68.46	541				
R/L 005.0407-20	5	0,75 - 1,0	1.9	5.0	4.4	35	20	3.3	0.40	0.45	69.40	542	69.40	542				
R/L 006.0510-22	6	1,0 - 1,25	2.3	6.0	5.3	37	22	3.4	0.55	0.55	70.33	544	70.33	544				
R/L 006.0510-15	6	1,0 - 1,25	2.3	6.0	5.3	30	15	3.4	0.55	0.55	68.46	543	68.46	543				
P											●		●		●		●	
M											●		●		●		●	
K											●		●		●		●	
N											●		●		●		●	
S											○		○		●		●	
H											○		○		●		●	
O											●		●		●		●	

→ v_c Page 59

UltraMini – Inserts for Internal thread turning (Full profile)

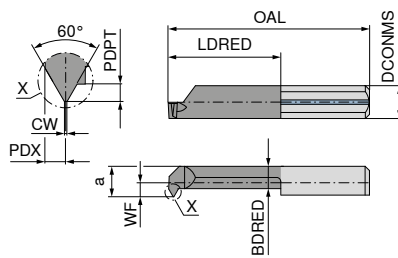
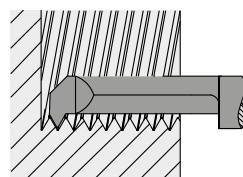

Illustrations show right-hand versions

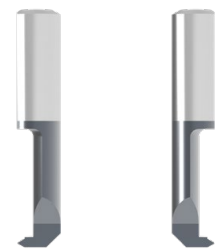

ISO designation	DCONMS _{hg} mm	TP mm	WF mm	DMIN mm	a mm	OAL mm	LDRED mm	BDRED mm	PDPT mm	PDX mm	CW mm	Left-hand 73 207 ...		Right-hand 73 206 ...	
												£		£	
R/L 104.0205-15	5	0.50	1.5	4	3.5	30	15	2.4	0.27	0.35	0.06	75.77	800	75.77	800
R/L 105.0205-15	5	0.50	1.9	5	4.4	30	15	3.3	0.27	0.35	0.06	71.90	802	71.90	802
R/L 105.0407-15	5	0.75	1.9	5	4.4	30	15	3.3	0.40	0.45	0.09	71.90	804	71.90	804
R/L 106.0510-15	6	1.00	2.3	6	5.3	30	15	3.4	0.54	0.55	0.12	71.90	806	71.90	806
P												●		●	
M												●		●	
K												●		●	
N												●		●	
S												●		●	
H												●		●	
O												●		●	

→ v_c Page 59

UltraMini – Inserts for internal thread turning (Partial profile)

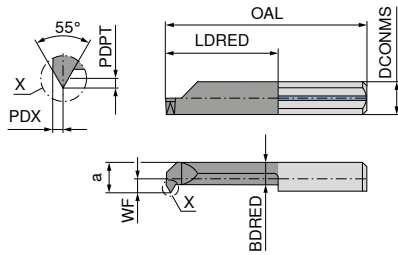
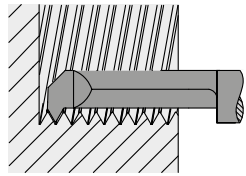

Illustrations show right-hand versions

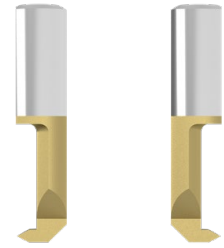

Left-hand Right-hand

ISO designation	DCONMS _{ns} mm	TPI 1/"	WF mm	DMIN mm	a mm	OAL mm	LDRED mm	BDRED mm	PDPT mm	PDX mm	73 105 ...		73 104 ...	
											£ Y5	552	£ Y5	552
R/L 005.5548-15	5	48 - 24	1.9	4.8	4.4	30	15	3.3	0.40	0.45	73.14	552	73.14	552
R/L 006.5548-15	6	48 - 24	2.3	6.0	5.3	30	15	3.4	0.40	0.45	73.14	562	73.14	562
R/L 006.5524-15	6	24 - 16	2.3	6.0	5.3	30	15	3.4	0.81	0.75	73.14	563	73.14	563
R/L 007.5524-15	7	24 - 16	2.7	7.0	6.3	30	15	3.8	0.81	0.75	73.14	572	73.14	572
P												●	●	
M												●	●	●
K												●	●	●
N												●	●	●
S												○	○	○
H												○	○	○
O												●	●	●

→ v_c Page 59

UltraMini – Inserts for axial grooving

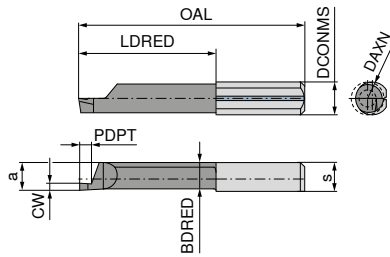
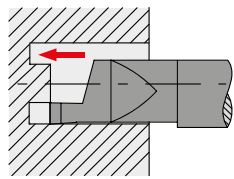

Illustrations show right-hand versions

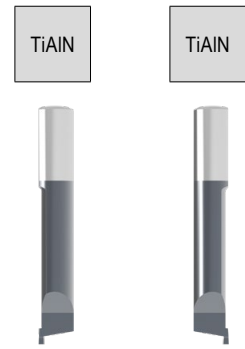

ISO designation	DCONMS _{h6} mm	a mm	DAXN mm	s mm	OAL mm	LDRED mm	PDPT mm	BDRED mm	CW mm	Left-hand 73 053 ...		Right-hand 73 052 ...	
										£ Y5		£ Y5	
R/L 010.1006-10	6	5.2	6	5.3	26	11	1.5	4.9	1.0	75.65	561	75.65	561
R/L 010.1506-10	6	5.2	6	5.3	26	11	2.0	4.9	1.5	75.65	563	75.65	563
R/L 010.1008-10	7	5.9	8	6.3	26	11	1.5	5.6	1.0	77.44	571	77.44	571
R/L 010.1008-20	7	5.9	8	6.3	35	20	1.5	5.6	1.0	82.73	671	82.73	671
R/L 010.1008-30	7	5.9	8	6.3	45	30	1.5	5.6	1.0	85.58	771	85.58	771
R/L 010.1508-10	7	5.9	8	6.3	26	11	2.5	5.6	1.5	77.44	573	77.44	573
R/L 010.1508-20	7	5.9	8	6.3	35	20	2.5	5.6	1.5	82.73	673	82.73	673
R/L 010.1508-30	7	5.9	8	6.3	45	30	2.5	5.6	1.5	85.58	773	85.58	773
R/L 010.2008-10	7	5.9	8	6.3	26	11	3.0	5.6	2.0	77.44	575	77.44	575
R/L 010.2008-20	7	5.9	8	6.3	35	20	3.0	5.6	2.0	82.73	675	82.73	675
R/L 010.2008-30	7	5.9	8	6.3	45	30	3.0	5.6	2.0	85.58	775	85.58	775
R/L 010.2508-10	7	5.9	8	6.3	26	11	3.5	5.6	2.5	77.44	577	77.44	577
R/L 010.2508-20	7	5.9	8	6.3	35	20	3.5	5.6	2.5	82.73	677	82.73	677
R/L 010.2508-30	7	5.9	8	6.3	45	30	3.5	5.6	2.5	85.58	777	85.58	777
R/L 010.3008-10	7	5.9	8	6.3	26	11	3.5	5.6	3.0	77.44	579	77.44	579
R/L 010.3008-20	7	5.9	8	6.3	35	20	3.5	5.6	3.0	82.73	679	82.73	679
R/L 010.3008-30	7	5.9	8	6.3	45	30	3.5	5.6	3.0	85.58	779	85.58	779
P											•		•
M											•		•
K											•		•
N											•		•
S											•		•
H											•		•
O											•		•

→ v_c Page 59

UltraMini – Inserts for axial grooving

▲ with corner radius

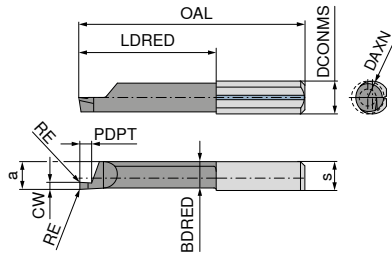
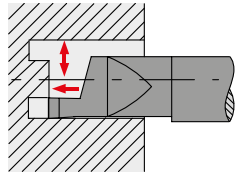
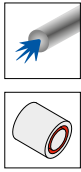

Illustrations show right-hand versions

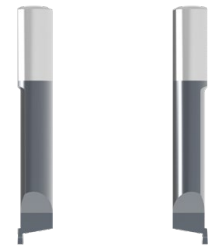

Left-hand Right-hand

ISO designation	DCONMS _{RE} mm	a mm	DAXN mm	s mm	OAL mm	LDRED mm	PDPT mm	BDRED mm	CW mm	RE mm	73 253 ...		73 252 ...	
											£		£	
R/L 510M1008-10	5	4.3	5	6.3	26	11	2	4.0	1.0	0.05	92.30	510	92.30	510
R/L 510M1008-20	5	4.3	5	6.3	35	20	2	4.0	1.0	0.05	97.47	610	97.47	610
R/L 510M1508-10	5	4.3	5	6.3	26	11	3	4.0	1.5	0.05	92.30	515	92.30	515
R/L 510M1508-20	5	4.3	5	6.3	35	20	3	4.0	1.5	0.05	97.47	615	97.47	615
R/L 510M2008-10	5	4.3	5	6.3	26	11	4	4.0	2.0	0.05	92.30	520	92.30	520
R/L 510M2008-20	5	4.3	5	6.3	35	20	4	4.0	2.0	0.05	97.47	620	97.47	620
R/L 010M1008-10	7	5.9	8	6.3	26	11	2	5.6	1.0	0.10	85.40	800	85.40	800
R/L 010M1008-20	7	5.9	8	6.3	35	20	2	5.6	1.0	0.10	90.22	810	90.22	810
R/L 010M1008-30	7	5.9	8	6.3	45	30	2	5.6	1.0	0.10	94.33	820	94.33	820
R/L 010M1508-10	7	5.9	8	6.3	26	11	3	5.6	1.5	0.10	85.40	802	85.40	802
R/L 010M1508-20	7	5.9	8	6.3	35	20	3	5.6	1.5	0.10	90.22	812	90.22	812
R/L 010M1508-30	7	5.9	8	6.3	45	30	3	5.6	1.5	0.10	94.33	822	94.33	822
R/L 010M2008-10	7	5.9	8	6.3	26	11	4	5.6	2.0	0.10	85.40	804	85.40	804
R/L 010M2008-20	7	5.9	8	6.3	35	20	4	5.6	2.0	0.10	90.22	814	90.22	814
R/L 010M2008-30	7	5.9	8	6.3	45	30	4	5.6	2.0	0.10	94.33	824	94.33	824
R/L 010M2508-10	7	5.9	8	6.3	26	11	5	5.6	2.5	0.10	85.40	806	85.40	806
R/L 010M2508-20	7	5.9	8	6.3	35	20	5	5.6	2.5	0.10	90.22	816	90.22	816
R/L 010M2508-30	7	5.9	8	6.3	45	30	5	5.6	2.5	0.10	94.33	826	94.33	826
R/L 010M3008-10	7	5.9	8	6.3	26	11	6	5.6	3.0	0.10	85.40	808	85.40	808
R/L 010M3008-20	7	5.9	8	6.3	35	20	6	5.6	3.0	0.10	90.22	818	90.22	818
R/L 010M3008-30	7	5.9	8	6.3	45	30	6	5.6	3.0	0.10	94.33	828	94.33	828
P												●		●
M												●		●
K												●		●
N												●		●
S												●		●
H												●		●
O												●		●

→ v. Page 59

UltraMini – Inserts for axial grooving (Full radius)

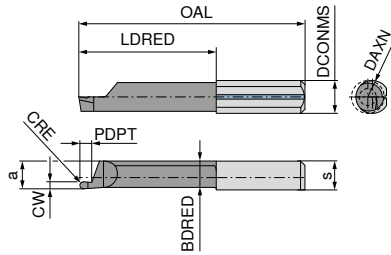
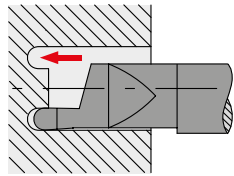

Illustrations show right-hand versions



Left-hand

Right-hand

ISO designation	DCONMS _{ns} mm	a mm	DAXN mm	s mm	OAL mm	LDRED mm	PDPT mm	BDFED mm	CW mm	CRE mm	73 059 ...		73 058 ...	
											£	071	£	071
R/L 610.1005-10	6	5.2	6	5.3	26	11	2	4.9	1.0	0.50	93.94	071	93.94	071
R/L 610.1005-20	6	5.2	6	5.3	35	20	2	4.9	1.0	0.50	99.46	171	99.46	171
R/L 610.1608-10	6	5.2	6	5.3	26	11	3	4.9	1.6	0.80	93.94	073	93.94	073
R/L 610.1608-20	6	5.2	6	5.3	35	20	3	4.9	1.6	0.80	99.46	173	99.46	173
R/L 610.2010-10	6	5.2	6	5.3	26	11	4	4.9	2.0	1.00	93.94	075	93.94	075
R/L 610.2010-20	6	5.2	6	5.3	35	20	4	4.9	2.0	1.00	99.46	175	99.46	175
R/L 610.2512-10	6	5.2	6	5.3	26	11	5	4.9	2.5	1.25	93.94	077	93.94	077
R/L 610.2512-20	6	5.2	6	5.3	35	20	5	4.9	2.5	1.25	99.46	177	99.46	177
R/L 610.3015-10	6	5.2	6	5.3	26	11	6	4.9	3.0	1.50	93.94	079	93.94	079
R/L 610.3015-20	6	5.2	6	5.3	35	20	6	4.9	3.0	1.50	99.46	179	99.46	179
R/L 010.1005-10	7	5.9	8	6.3	26	11	2	5.6	1.0	0.50	90.13	571	90.13	571
R/L 010.1005-20	7	5.9	8	6.3	35	20	2	5.6	1.0	0.50	95.38	671	95.38	671
R/L 010.1608-10	7	5.9	8	6.3	26	11	3	5.6	1.6	0.80	90.13	573	90.13	573
R/L 010.1608-20	7	5.9	8	6.3	35	20	3	5.6	1.6	0.80	95.38	673	95.38	673
R/L 010.2010-10	7	5.9	8	6.3	26	11	4	5.6	2.0	1.00	90.13	575	90.13	575
R/L 010.2010-20	7	5.9	8	6.3	35	20	4	5.6	2.0	1.00	95.38	675	95.38	675
R/L 010.2512-10	7	5.9	8	6.3	26	11	5	5.6	2.5	1.25	90.13	577	90.13	577
R/L 010.2512-20	7	5.9	8	6.3	35	20	5	5.6	2.5	1.25	95.38	677	95.38	677
R/L 010.3015-10	7	5.9	8	6.3	26	11	6	5.6	3.0	1.50	90.13	579	90.13	579
R/L 010.3015-20	7	5.9	8	6.3	35	20	6	5.6	3.0	1.50	95.38	679	95.38	679
P												●		●
M												●		●
K												●		●
N												●		●
S												●		●
H												●		●
O												●		●

UltraMini – Inserts for axial grooving over a spigot

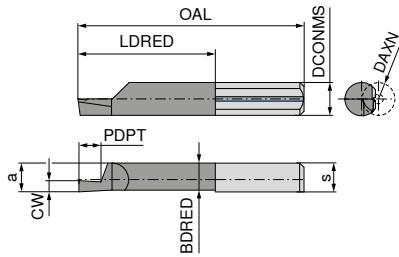
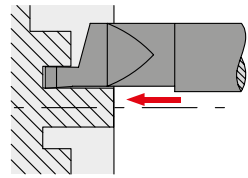

Illustrations show right-hand versions

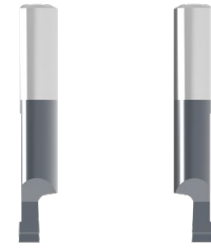

Left-hand Right-hand

ISO designation	DCONMS _{ns} mm	a mm	DAXN mm	s mm	OAL mm	LDRED mm	PDPT mm	BDRED mm	CW mm	73 061 ...		73 060 ...	
										£ Y5		£ Y5	
R/L 620.1006-20	6	5.2	6	5.3	35	20	2	4.9	1.0	95.38	561	95.38	561
R/L 620.1506-20	6	5.2	6	5.3	35	20	3	4.9	1.5	95.38	563	95.38	563
R/L 620.2006-20	6	5.2	6	5.3	35	20	4	4.9	2.0	95.38	565	95.38	565
R/L 620.2506-20	6	5.2	6	5.3	35	20	5	4.9	2.5	95.38	567	95.38	567
R/L 620.3006-20	6	5.2	6	5.3	35	20	6	4.9	3.0	95.38	569	95.38	569

P											●		●
M											●		●
K											●		●
N											●		●
S											●		●
H											●		●
O											●		●

→ v_c Page 59

UltraMini – Inserts for axial grooving over a spigot

▲ with corner radius

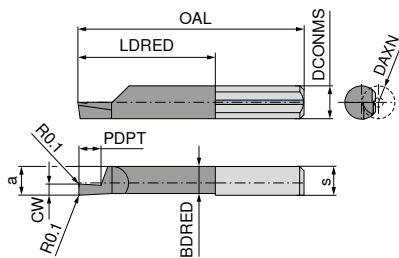
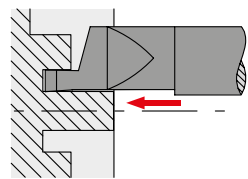

Illustrations show right-hand versions

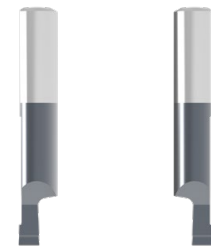

Left-hand Right-hand

ISO designation	DCONMS _{ns} mm	a mm	DAXN mm	s mm	OAL mm	LDRED mm	PDPT mm	BDRED mm	CW mm	73 261 ...		73 260 ...	
										£ Y5		£ Y5	
R/L 620M1006-20	6	5.2	6	5.3	35	20	2	4.9	1.0	91.21	800	91.21	800
R/L 620M1506-20	6	5.2	6	5.3	35	20	3	4.9	1.5	91.21	802	91.21	802
R/L 620M2006-20	6	5.2	6	5.3	35	20	4	4.9	2.0	91.21	804	91.21	804
R/L 620M2506-20	6	5.2	6	5.3	35	20	5	4.9	2.5	91.21	806	91.21	806
R/L 620M3006-20	6	5.2	6	5.3	35	20	6	4.9	3.0	91.21	808	91.21	808

P											●		●
M											●		●
K											●		●
N											●		●
S											●		●
H											●		●
O											●		●

→ v_c Page 59

UltraMini – Inserts for axial grooving

- ▲ up to 70 bar
- ▲ dual cooling channel

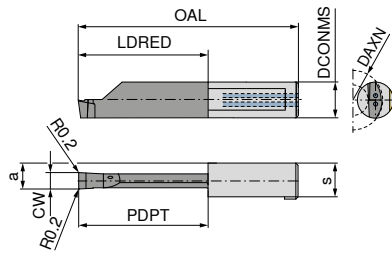
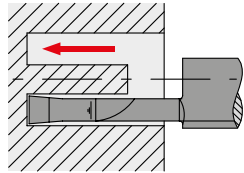
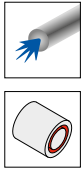

Illustrations show right-hand versions



Left-hand Right-hand

ISO designation	DCONMS _{hg} mm	a mm	DAXN mm	s mm	OAL mm	LDRED mm	PDPT mm	CW mm	73 263 ...		73 262 ...	
									£		£	
R/L 012.0200-10	8	5.00	12	7.3	30	10	10	2.0	84.39	700	84.39	700
R/L 012.0200-15	8	5.00	12	7.3	35	15	15	2.0	86.04	702	86.04	702
R/L 012.0250-10	8	5.25	12	7.3	30	10	10	2.5	84.39	704	84.39	704
R/L 012.0250-20	8	5.25	12	7.3	40	20	20	2.5	87.58	706	87.58	706
R/L 016.0300-10	8	5.50	16	7.3	30	10	10	3.0	119.66	800	119.66	800
R/L 016.0300-20	8	5.50	16	7.3	40	20	20	3.0	122.84	802	122.84	802
R/L 020.0300-25	8	5.50	20	7.3	45	25	25	3.0	124.51	804	124.51	804
R/L 020.0300-30	8	5.50	20	7.3	50	30	30	3.0	124.51	806	124.51	806
R/L 020.0300-35	8	5.50	20	7.3	55	35	35	3.0	127.40	808	127.40	808
R/L 020.0300-40	8	5.50	20	7.3	60	40	40	3.0	127.40	810	127.40	810
R/L 016.0400-10	8	6.00	16	7.3	30	10	10	4.0	119.66	812	119.66	812
R/L 016.0400-20	8	6.00	16	7.3	40	20	20	4.0	122.84	814	122.84	814
R/L 020.0400-25	8	6.00	20	7.3	45	25	25	4.0	124.51	816	124.51	816
R/L 020.0400-30	8	6.00	20	7.3	50	30	30	4.0	124.51	818	124.51	818
R/L 020.0400-35	8	6.00	20	7.3	55	35	35	4.0	127.40	820	127.40	820
R/L 020.0400-40	8	6.00	20	7.3	60	40	40	4.0	127.40	822	127.40	822
R/L 020.0500.20	8	6.50	20	7.3	40	20	20	5.0	119.66	824	119.66	824
R/L 020.0500.25	8	6.50	20	7.3	45	25	25	5.0	121.12	826	121.12	826
R/L 020.0500.30	8	6.50	20	7.3	50	30	30	5.0	121.12	828	121.12	828
R/L 020.0500.35	8	6.50	20	7.3	55	35	35	5.0	124.51	830	124.51	830
R/L 020.0500.40	8	6.50	20	7.3	60	40	40	5.0	121.08	832	121.08	832
P										●		●
M										●		●
K										●		●
N										●		●
S										●		●
H										●		●
O										●		●

UltraMini – Inserts for axial grooving

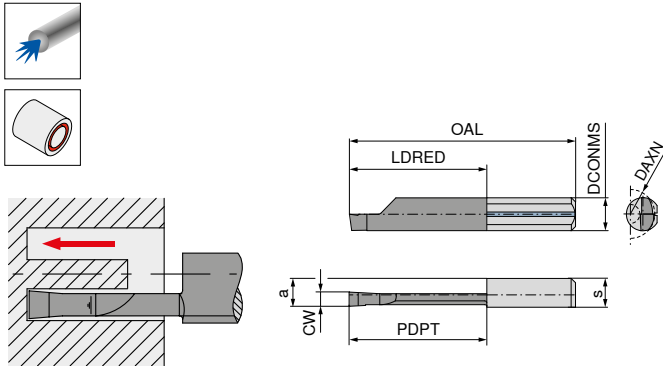

Illustrations show right-hand versions

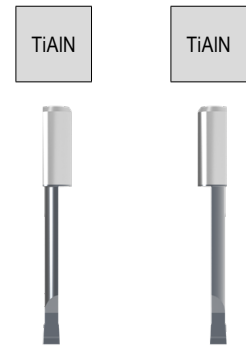

ISO designation	DCONMS _{ns} mm	a mm	DAXN mm	s mm	OAL mm	LDRED mm	PDPT mm	CW mm
R/L 015.2515-20	7	5.9	15	6.3	35	20	20	2.5
R/L 015.3015-20	7	5.9	15	6.3	35	20	20	3.0
R/L 015.3015-30	7	5.9	15	6.3	45	30	30	3.0

	Left-hand 73 057 ...		Right-hand 73 056 ...	
	£		£	
	Y5		Y5	
	103.87	572	103.87	572
	103.87	574	103.87	574
	114.54	674	114.54	674
P		●		●
M		●		●
K		●		●
N		●		●
S		●		●
H		●		●
O		●		●

→ v_c Page 59

UltraMini – Inserts for axial grooving

▲ with corner radius

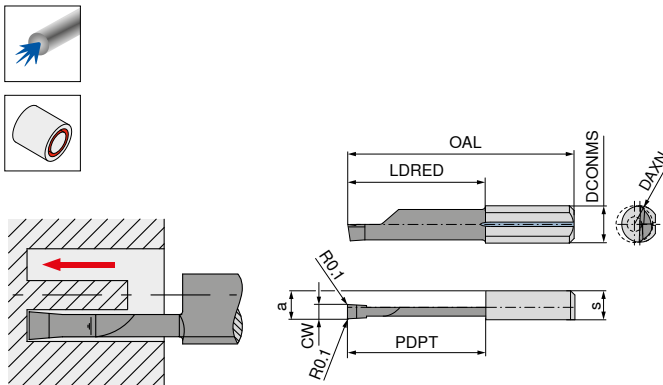

Illustrations show right-hand versions

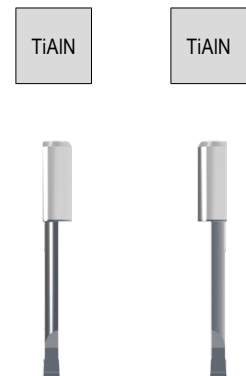

ISO designation	DCONMS _{ns} mm	a mm	DAXN mm	s mm	OAL mm	LDRED mm	PDPT mm	CW mm
R/L 015M2515-20	7	5.9	8	6.3	35	20	20	2.5
R/L 015M3015-20	7	5.9	8	6.3	35	20	20	3.0
R/L 015M3015-30	7	5.9	8	6.3	45	30	30	3.0

	Left-hand 73 257 ...		Right-hand 73 256 ...	
	£		£	
	Y5		Y5	
	99.90	800	99.90	800
	99.90	802	99.90	802
	109.29	804	109.29	804
P		●		●
M		●		●
K		●		●
N		●		●
S		●		●
H		●		●
O		●		●

→ v_c Page 59

UltraMini – Set: Internal turning, grooving and chamfering, right hand

- ▲ extensive assortment of right-hand tools
- ▲ K10F - TiN

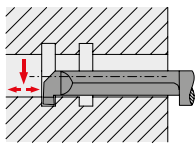

Grooving (E)

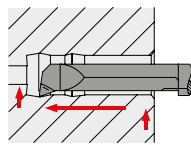

Profile turn (A)

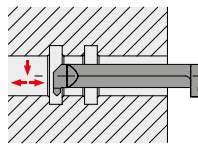

Chamfers (F)



73 085 ...

Tool	Designation	Article no.	Bore Ø mm	Boring depth mm	Grooving depth mm	Groove width mm	Piece	fig.	£ Y5
Inserts	R 004.0100-16	73 002 541	4	16	0,8	1,0	1	E	
Inserts	R 005.0150-20	73 002 552	5	20	1,0	1,5	1	E	
Inserts	R 005.0200-20	73 002 553	5	20	1,0	2,0	1	E	
Inserts	R 006.0150-22	73 002 562	6	22	1,8	1,5	1	E	
Inserts	R 006.0200-22	73 002 563	6	22	1,8	2,0	1	E	
Inserts	R 050.3-16	73 004 530	3	16			1	A	1,210.40
Inserts	R 050.4-16	73 004 540	4	16			1	A	
Inserts	R 050.5-20	73 004 550	5	20			1	A	
Inserts	R 050.6-22	73 004 560	6	22			1	A	
Inserts	R 060.5-20	73 006 550	5	20			1	F	
Tool holder	645.0016-D	73 080 164					1		
Tool holder	676.0016-D	73 080 166					1		
Tightening Key	110.645	70 950 175					1		

999

UltraMini – Set: Internal Turning

- ▲ extensive assortment of right-hand tools
- ▲ K10F - TiN

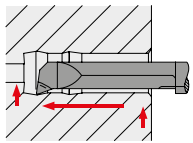

73 085 ...

Tool	Designation	Article no.	Bore Ø mm	Boring depth mm	Piece	£ Y5
Inserts	R 050.3-16	73 004 530	3	16	1	
Inserts	R 050.4-16	73 004 540	4	16	1	
Inserts	R 050.5-20	73 004 550	5	20	1	760.73
Inserts	R 050.6-22	73 004 560	6	22	1	
Tool holder	645.0016-D	73 080 164			1	
Tool holder	676.0016-D	73 080 166			1	
Tightening Key	110.645	70 950 175			1	

994

12

UltraMini – Set: Holder



73 085 ...

Tool	Designation	Article no.	for cutting insert Ø mm	Piece	£ Y5
Tool holder	645.0016-D	73 080 164	3 / 4 / 5	1	
Tool holder	676.0016-D	73 080 166	6 / 7	1	474.30
Tightening Key	110.645	70 950 175		1	

990

UltraMini – Set: Axial Grooving

- ▲ extensive assortment of right-hand tools
- ▲ K10F - TiN

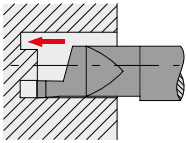

73 085 ...

Tool	Designation	Article no.	Bore Ø mm	Boring depth mm	Grooving depth mm	Groove width mm	Piece	£ Y5
Inserts	R 010.1008-10	73 050 571	8	10	1,5	1,0	1	
Inserts	R 010.1508-10	73 050 573	8	10	2,5	1,5	1	
Inserts	R 010.2008-10	73 050 575	8	10	3,0	2,0	1	614.16
Inserts	R 010.2508-20	73 050 677	8	20	3,5	2,5	1	
Inserts	R 010.3008-20	73 050 679	8	20	3,5	3,0	1	
Tool holder	676.0016-D	73 080 166					1	
Tightening Key	110.645	70 950 175					1	

996

UltraMini – Standard tool holder for cutting inserts

- ▲ double ended
- ▲ Machining diameter from Ø 0.5 mm

Scope of supply:

Tool holder with allen key

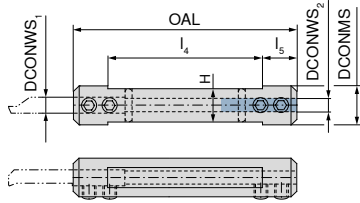

Designation	DCONWS ₁ mm	DCONWS ₂ mm	DCONMS mm	OAL mm	l ₄ mm	l ₅ mm	H mm	73 080 ...	
								£	
645.0012-D	4	5	12.00	75	55	10	10.3	Y5	163
645.0016-D	4	5	16.00	75	55	10	14.0	219.68	164
645.001905-D	4	5	19.05	90	70	10	17.2	230.74	170
645.0020-D	4	5	20.00	90	70	10	18.0	192.24	165
645.0022-D	4	5	22.00	90	70	10	20.0	248.47	171
645.00254-D	4	5	25.40	95	75	10	23.4	200.47	172
676.0016-D	6	7	16.00	75	55	10	14.0	212.83	166
676.001905-D	6	7	19.05	90	70	10	17.2	230.74	173
676.0020-D	6	7	20.00	90	70	10	18.0	192.24	167
676.0022-D	6	7	22.00	90	70	10	20.0	248.47	174
676.00254-D	6	7	25.40	95	75	10	23.4	200.47	175
687.0016-D	7	8	16.00	75	55	10	14.0	212.83	168
687.0020-D	7	8	20.00	90	70	10	18.0	267.58	169
								286.39	

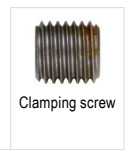

Spare parts for Article no.

Article no.		70 950 ...		73 082 ...	
		£		£	
73 080 163	SW2,5	2.83	175	M5x4	8.88 013
73 080 164	SW2,5	2.83	175	M5x6	7.29 001
73 080 170	SW2,5	2.83	175	M5x6	7.29 001
73 080 165	SW2,5	2.83	175	M5x8	8.85 008
73 080 171	SW2,5	2.83	175	M5x8	8.85 008
73 080 172	SW2,5	2.83	175	M5x8	8.85 008
73 080 166	SW2,5	2.83	175	M5x6	7.29 001
73 080 173	SW2,5	2.83	175	M5x6	7.29 001
73 080 167	SW2,5	2.83	175	M5x8	8.85 008
73 080 174	SW2,5	2.83	175	M5x8	8.85 008
73 080 175	SW2,5	2.83	175	M5x8	8.85 008
73 080 168	SW2,5	2.83	175	M6x6	10.38 014
73 080 169	SW2,5	2.83	175	M6x6	10.38 014

UltraMini – Quick change tool holder for cutting inserts

Scope of supply:

Tool holder, lock nut and clamping wedge

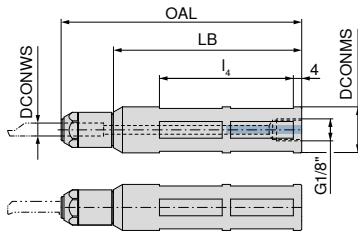

73 089 ...

Designation	DCONWS mm	DCONMS ^{g6} mm	OAL mm	LB mm	l _i mm	£	
						Y5	
UM600H.0012.4	4	12.00	115	90	64	414.67	124
UM600H.0016.4	4	16.00	115	90	64	376.21	164
UM600H.001905.4	4	19.05	115	90	64	403.69	194
UM600H.0020.4	4	20.00	115	90	64	398.20	204
UM600H.0022.4	4	22.00	115	90	64	405.06	224
UM600H.0025.4	4	25.00	115	90	64	413.30	254
UM600H.00254.4	4	25.40	115	90	64	421.54	264
UM600H.0028.4	4	28.00	115	90	64	421.54	284
UM600H.0012.5	5	12.00	115	90	64	414.67	125
UM600H.0016.5	5	16.00	115	90	64	376.21	165
UM600H.001905.5	5	19.05	115	90	64	403.69	195
UM600H.0020.5	5	20.00	115	90	64	398.20	205
UM600H.0022.5	5	22.00	115	90	64	405.06	225
UM600H.0025.5	5	25.00	115	90	64	413.30	255
UM600H.00254.5	5	25.40	115	90	64	421.54	265
UM600H.0028.5	5	28.00	115	90	64	421.54	285
UM600H.0012.6	6	12.00	115	90	64	414.67	126
UM600H.0016.6	6	16.00	115	90	64	376.21	166
UM600H.001905.6	6	19.05	115	90	64	403.69	196
UM600H.0020.6	6	20.00	115	90	64	398.20	206
UM600H.0022.6	6	22.00	115	90	64	405.06	226
UM600H.0025.6	6	25.00	115	90	64	413.30	256
UM600H.00254.6	6	25.40	115	90	64	421.54	266
UM600H.0028.6	6	28.00	115	90	64	421.54	286
UM600H.0012.7	7	12.00	115	90	64	414.67	127
UM600H.0016.7	7	16.00	115	90	64	376.21	167
UM600H.001905.7	7	19.05	115	90	64	403.69	197
UM600H.0020.7	7	20.00	115	90	64	398.20	207
UM600H.0022.7	7	22.00	115	90	64	405.06	227
UM600H.0025.7	7	25.00	115	90	64	413.30	257
UM600H.00254.7	7	25.40	115	90	64	421.54	267
UM600H.0028.7	7	28.00	115	90	64	421.54	287

Avoid pulling cuts. Ensure a suitable clamping force is used when using thro' coolant supply. Can be tightened using a key.

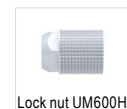

Spare parts

DCONWS		73 950 ...		73 950 ...	
		£		£	
4	M4	93.37	104	60.42	111
5	M5	93.37	105	60.42	111
6	M6	93.37	106	60.42	111
7	M7	93.37	107	60.42	111

UltraMini – Toolholder for inserts

▲ single ended

Scope of supply:

Tool holder with allen key

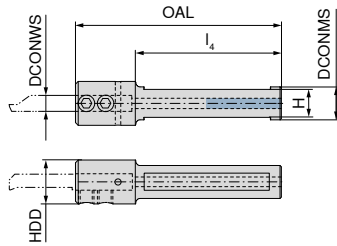

Designation	DCONWS mm	HDD mm	DCONMS mm	OAL mm	l ₄ mm	H mm
640.0012-D	4	16	12	75	53	10.2
650.0012-D	5	16	12	75	53	10.2
660.0012-D	6	16	12	75	53	10.2
670.0012-D	7	16	12	75	53	10.2
680.0012-D	8	16	12	75	53	10.2

73 081 ...

£	
Y5	
226.56	264
226.56	265
323.96	266
323.96	267
323.96	268



Key I

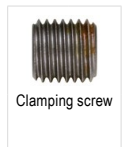

Clamping screw

70 950 ...

73 082 ...

Spare parts

DCONWS		£		£	
4	SW2,5	2.83	175	M5x0,5x6	5.84 010
5	SW2,5	2.83	175	M5x0,5x6	5.84 010
6	SW2,5	2.83	175	M5x0,5x6	5.84 010
7	SW2,5	2.83	175	M5x0,5x6	5.84 010
8	SW2,5	2.83	175	M5x0,5x6	5.84 010

UltraMini – Toolholder for inserts

Scope of supply:

Tool holder with allen key

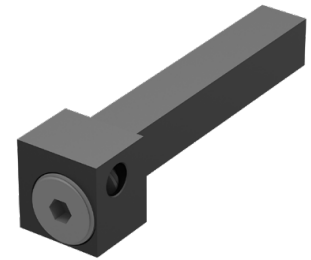
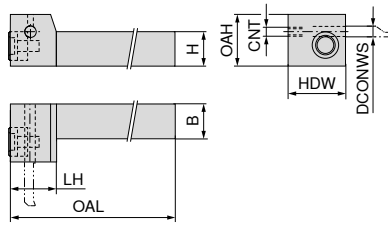

ISO designation	DCONWS mm	OAL mm	LH mm	B mm	HDW mm	H mm	OAH mm	CNT	Left-hand 73 083 ...		Right-hand 73 084 ...	
									£		£	
R/L .IK.UHCM.1212.4	4	90	17	12	20	12	18	M5	Y5		Y5	
R/L .IK.UHCM.1212.5	5	90	17	12	20	12	18	M5	411.83	124	411.83	124
R/L .IK.UHCM.1212.6	6	90	17	12	20	12	21	M5	411.83	126	411.83	126
R/L .IK.UHCM.1212.7	7	90	17	12	20	12	21	M5	411.83	127	411.83	127

Suitable coolant connections can be found in our sliding head tooling catalogue.

Spare parts

DCONWS		£					
4	SW5	7.73	050	UM 12	48.87	011	
5	SW5	7.73	050	UM 12	48.87	011	
6	SW5	7.73	050	UM 16	48.87	012	
7	SW5	7.73	050	UM 16	48.87	012	



Clamping key – T

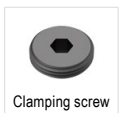

Clamping screw

UltraMini – Toolholder for inserts

Scope of supply:

Tool holder with allen key

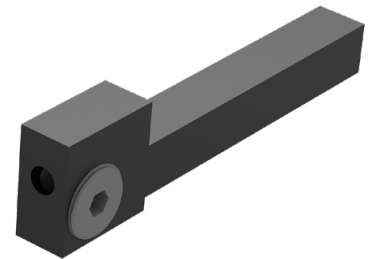
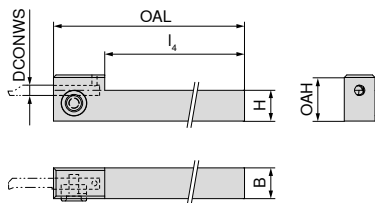

Designation	DCONWS mm	OAL mm	l ₄ mm	B mm	H mm	OAH mm	73 086 ...	
							£	
UM.1010.4	4	100	75	10	10	20	Y5	
UM.1010.5	5	100	75	10	10	20	411.83	104
UM.1212.4	4	100	75	12	12	22	411.83	124
UM.1212.5	5	100	75	12	12	22	411.83	125
UM.1212.6	6	100	75	12	12	22	411.83	126

Spare parts

DCONWS		£					
4	SW5	7.73	050	UM 12	48.87	011	
5	SW5	7.73	050	UM 12	48.87	011	
6	SW5	7.73	050	UM 16	48.87	012	



Clamping key – T



Clamping screw

MiniCut – Insert for turning and profiling

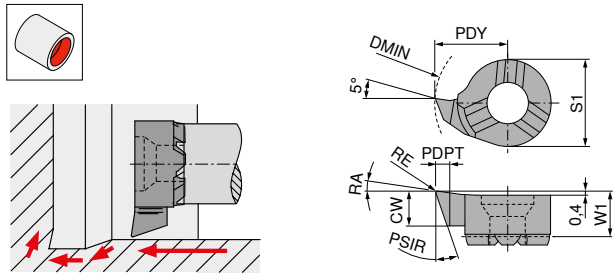

Illustrations show right-hand versions

Size	ISO designation	DMIN mm	CW mm	W1 mm	PDY mm	S1 mm	RE mm	PDPT mm	PSIR °	RA °	Left-hand		Right-hand	
											73 324 ...	73 322 ...	£	£
08	8,00. R/L .3,30.18°	7.8	3.3	3.5	4.65	6.0	0.20	0.6	18	8	Y5	033	Y5	033
	8,00. R/L .3,50.18°	7.8	3.5	3.5	4.65	6.0	0.05	0.6	18	8	47.06	035	47.06	035
	8,00. R/L .3,50.20°	7.8	3.5	3.5	4.65	6.0	0.20	0.6	20	20	51.10	135	51.10	135
09	9,00. R/L .3,60.18°	9.0	3.6	3.6	5.50	6.2	0.20	0.8	18	8	44.52	136	44.52	136
	9,00. R/L .3,60.20°	9.0	3.6	3.6	5.50	6.2	0.20	0.8	20	20	50.33	236	50.33	236
11	9,80. R/L .3,90.18°	9.8	3.9	4.2	5.50	8.0	0.20	1.0	18	8	47.06	139	47.06	139
	11,00. R/L .3,90.18°	11.0	3.9	4.2	6.70	8.0	0.20	1.0	18	8	46.53	339	46.53	339
	11,00. R/L .4,20.20°	11.0	4.2	4.2	6.70	8.0	0.20	1.0	20	20	50.33	342	50.33	342
14	14,00. R/L .5,00.18°	13.8	5.0	5.1	8.70	9.0	0.20	1.5	18	8	46.53	550	46.53	550
	14,00. R/L .5,30.20°	14.0	5.3	5.3	8.70	9.0	0.20	1.5	20	20	50.33	553	50.33	553
16	15,50. R/L .5,00.18°	15.5	5.0	5.4	9.70	11.0	0.20	1.5	18	8	50.85	750	50.85	750
P											•		•	
M											•		•	
K											•		•	
N											•		•	
S											•		•	
H											•		•	
O											•		•	

→ v_c Page 59

MiniCut – Insert for copy turning

▲ with chip breaker

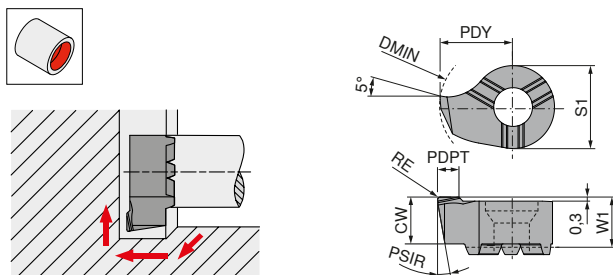

Illustrations show right-hand versions

Size	ISO designation	DMIN mm	CW mm	W1 mm	PDY mm	S1 mm	RE mm	PDPT mm	PSIR °	Left-hand		Right-hand	
										73 388 ...	73 386 ...	£	£
08	8,00. R/L .3,40.10°	8	3.4	3.5	4.65	6.0	0.2	0.5	10	Y5	13400	Y5	13400
09	9,00. R/L .3,50.10°	9	3.5	3.6	5.50	6.2	0.2	0.5	10	40.97	136	40.97	136
11	11,00. R .4,10.10°	11	4.1	4.2	6.70	8.0	0.2	0.5	10	39.33	14100	39.33	14100
P											•		•
M											•		•
K											•		•
N											•		•
S											•		•
H											•		•
O											•		•

→ v_c Page 59

MiniCut – CBN insert for profiling – hard turning

▲ 56 to 65 HRC

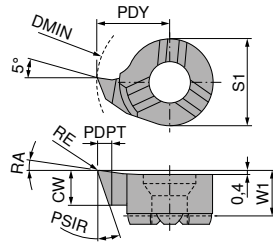
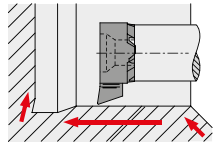

Illustrations show right-hand versions

Size	ISO designation	DMIN mm	CW mm	W1 mm	PDY mm	S1 mm	RE mm	PDPT mm	PSIR °	RA °	Left-hand CBN		Right-hand CBN	
											73 368 ...	033	73 366 ...	033
08	8,00. R/L .3,30.18°	7.8	3.3	3.5	4.65	6	0.2	0.39	18	8	£ Y5 212.78	033	£ Y5 212.78	033
11	11,00. R/L .3,90.18°	11.0	3.9	4.2	6.70	8	0.2	0.55	18	8	222.70	139	222.70	139
14	14,00. R/L .5,00.18°	13.8	5.0	5.3	8.70	9	0.2	0.69	18	8	235.96	550	235.96	550
16	16,00. R/L .5,00.18°	15.5	5.0	5.4	9.70	11	0.2	0.77	18	8	246.04	750	246.04	750
P														
M														
K														
N														
S												○	○	
H												●	●	
O														

→ v_c Page 59

MiniCut – Internal turning insert

▲ CDX = a_{pmax}

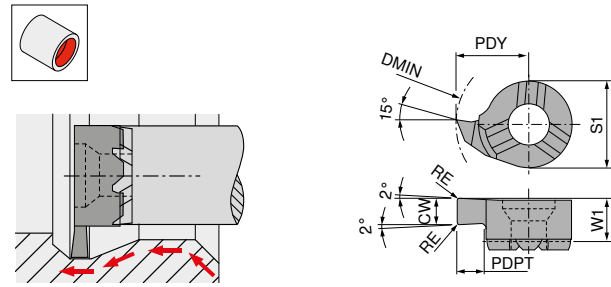

Illustrations show right-hand versions

Size	ISO designation	DMIN mm	CW $_{-0.05}$ mm	PDPT mm	W1 mm	PDY mm	S1 mm	RE mm	CDX mm	Left-hand		Right-hand	
										73 316 ...	73 314 ...	73 316 ...	73 314 ...
08	8,00. R/L .1,50,1,0	8	1.5	1.0	3.3	4.8	6.0	0.2	0.2	£ Y5 47.61	015	£ Y5 47.61	015
	8,00. R/L .2,00,1,0	8	2.0	1.0	3.3	4.8	6.0	0.2	0.2	45.44	020	45.44	020
09	9,00. R/L .1,50,2,0	9	1.5	2.0	3.6	5.5	6.2	0.2	0.2	48.66	115	48.66	115
	9,00. R/L .1,50,3,0	10	1.5	3.0	3.6	6.5	6.2	0.2	0.2	48.66	121	48.66	121
	9,00. R/L .2,00,2,0	9	2.0	2.0	3.6	5.5	6.2	0.2	0.2	43.15	120	43.15	120
	9,00. R/L .2,00,3,0	10	2.0	3.0	3.6	6.5	6.2	0.2	0.2	43.15	122	43.15	122
11	11,00. R/L .1,50,2,3	11	1.5	2.3	4.2	6.7	8.0	0.2	0.2	50.12	315	50.12	315
	11,00. R/L .2,00,2,3	11	2.0	2.3	4.2	6.7	8.0	0.2	0.2	47.06	320	47.06	320
14	14,00. R/L .1,50,4,0	14	1.5	4.0	5.3	9.0	9.0	0.2	0.2	45.96	515	45.96	515
	14,00. R/L .1,50,5,5	16	1.5	5.5	5.2	10.5	9.0	0.2	0.2	58.48	516	58.48	516
	14,00. R/L .1,50,6,5	17	1.5	6.5	5.2	11.5	9.0	0.2	0.2	58.48	517	58.48	517
	14,00. R/L .2,00,4,0	14	2.0	4.0	5.3	9.0	9.0	0.2	0.2	47.06	520	47.06	520
	14,00. R/L .2,00,5,5	16	2.0	5.5	5.2	10.5	9.0	0.2	0.2	58.48	521	58.48	521
	14,00. R/L .2,00,6,5	17	2.0	6.5	5.2	11.5	9.0	0.2	0.2	58.48	522	58.48	522
	14,00. R/L .2,50,5,5	16	2.5	5.5	5.2	10.5	9.0	0.2	0.2	58.48	525	58.48	525
	14,00. R/L .2,50,6,5	17	2.5	6.5	5.2	11.5	9.0	0.2	0.2	58.48	526	58.48	526
	14,00. R/L .3,00,5,5	16	3.0	5.5	5.2	10.5	9.0	0.2	0.2	58.48	530	58.48	530
	14,00. R/L .3,00,6,5	17	3.0	6.5	5.2	11.5	9.0	0.2	0.2	58.48	531	58.48	531
16	16,00. R/L .2,00,4,3	16	2.0	4.3	5.4	10.2	11.0	0.2	0.2	51.31	720	51.31	720
P											●		●
M											●		●
K											●		●
N											●		●
S											●		●
H											●		●
O											●		●

→ v_c Page 59

MiniCut – Back boring insert

▲ CDX = a_{pmax}

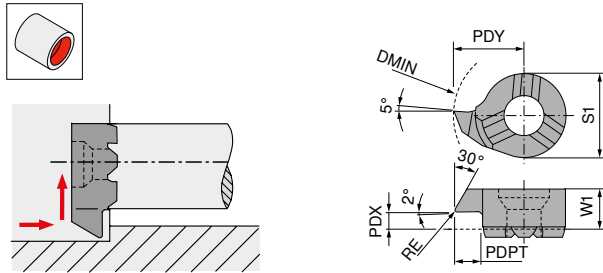

Illustrations show right-hand versions

Size	ISO designation	DMIN mm	PDPT mm	W1 mm	PDX mm	PDY mm	S1 mm	RE mm	CDX mm
08	8,00. R/L .30°1,3	7.8	1.3	3.50	1.0	4.65	6.0	0.2	0.6
09	9,00. R/L .30°1,7	9.0	1.7	3.55	1.2	5.50	6.2	0.2	0.8
	9,00. R/L .30°2,3	10.0	2.3	3.55	1.2	6.50	6.2	0.2	0.8
11	11,00. R/L .30°2,3	11.0	2.3	4.30	1.6	6.70	8.0	0.2	1.0
14	14,00. R/L .30°3,5	13.8	3.5	5.40	2.4	8.70	9.0	0.2	1.5

	Left-hand 73 332 ...	Right-hand 73 330 ...
	£ Y5	£ Y5
	54.14 013	54.14 013
	49.42 117	49.42 117
	49.42 123	49.42 123
	53.02 323	53.02 323
	54.14 535	54.14 535
P	●	●
M	●	●
K	●	●
N	●	●
S	●	●
H	●	●
O	●	●

→ v_c Page 59

MiniCut – Internal turning and chamfering insert

▲ CDX = a_{pmax}

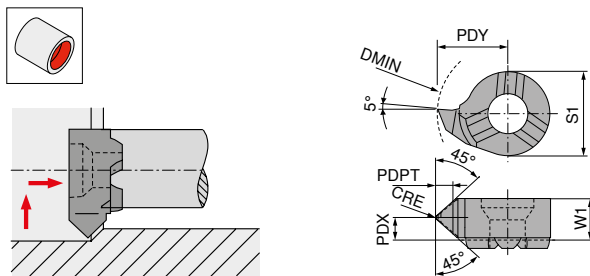

Illustrations show right-hand versions

Size	ISO designation	DMIN mm	PDPT mm	W1 mm	PDX mm	PDY mm	S1 mm	CRE mm	CDX mm
08	8,00. R/L .45°1,4	8	1.4	3.50	1.8	4.8	6.0	0.2	0.6
09	9,00. R/L .45°1,3	9	1.3	3.55	1.8	5.5	6.2	0.2	0.8
	11,00. R/L .45°1,5	11	1.5	4.30	2.2	6.7	8.0	0.2	1.0
14	14,00. R/L .45°1,5	14	1.5	5.40	2.8	9.0	9.0	0.2	1.2

	Left-hand 73 336 ...	Right-hand 73 334 ...
	£ Y5	£ Y5
	45.23 010	45.23 010
	42.38 110	42.38 110
	45.23 310	45.23 310
	48.86 510	48.86 510
P	●	●
M	●	●
K	●	●
N	●	●
S	●	●
H	●	●
O	●	●

→ v_c Page 59

MiniCut – Insert for pregrooving and chamfering

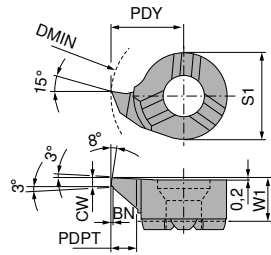
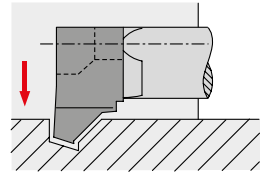

Illustrations show right-hand versions

Size	ISO designation	DMIN mm	CW mm	PDPT mm	W1 mm	PDY mm	S1 mm	BN mm	Left-hand		Right-hand	
									73 340 ...	73 338 ...	73 340 ...	73 338 ...
08	8,00. R/L .1,00.45°	8	1	1.0	3.3	4.8	6.0	0.2	£ Y5 45.97	100	£ Y5 45.97	100
09	9,00. R/L .1,00.45°	9	1	1.5	3.6	5.5	6.2	0.2	43.78	215	43.78	215
11	11,00. R/L .1,00.45°	11	1	1.5	4.2	6.7	8.0	0.2	45.97	315	45.97	315
14	14,00. R/L .1,00.45°	14	1	1.5	5.3	9.0	9.0	0.2	45.97	515	45.97	515
16	16,00. R/L .1,00.45°	16	1	1.5	5.4	10.2	11.0	0.2	45.97	715	45.97	715
P										●		●
M										●		●
K										●		●
N										●		●
S										●		●
H										●		●
O										●		●

→ v_c Page 59

MiniCut – Grooving insert

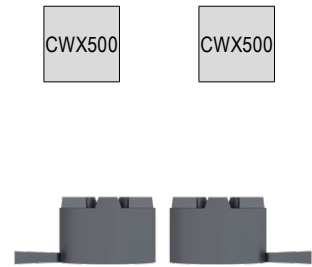
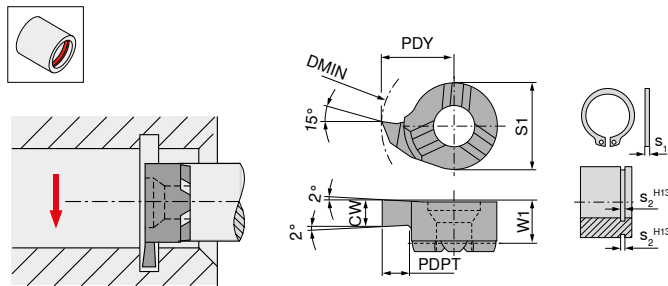

Illustrations show right-hand versions

Size	ISO designation	DMIN mm	CW mm	PDPT mm	W1 mm	s ₁ mm	s ₂ H13 mm	PDY mm	S1 mm	Left-hand		Right-hand	
										73 312 ...	£	73 310 ...	£
08	8,00. R/L .0,73.1,0	8	0,73	1,0	3,3	0,6	0,7	4,8	6,0	40.66	073	40.66	073
	8,00. R/L .0,83.1,0	8	0,83	1,0	3,3	0,7	0,8	4,8	6,0	40.66	083	40.66	083
	8,00. R/L .0,93.1,0	8	0,93	1,0	3,3	0,8	0,9	4,8	6,0	40.66	093	40.66	093
	8,00. R/L .1,00.1,0	8	1,00	1,0	3,3			4,8	6,0	40.66	110	40.66	110
	8,00. R/L .1,20.1,0	8	1,20	1,0	3,3	1,0	1,1	4,8	6,0	40.66	112	40.66	112
	8,00. R/L .1,40.1,0	8	1,40	1,0	3,3	1,2	1,3	4,8	6,0	40.66	114	40.66	114
	8,00. R/L .1,50.1,0	8	1,50	1,0	3,3			4,8	6,0	40.66	115	40.66	115
	8,00. R/L .1,70.1,0	8	1,70	1,0	3,3	1,5	1,6	4,8	6,0	40.66	117	40.66	117
	8,00. R/L .2,00.1,0	8	2,00	1,0	3,3			4,8	6,0	40.66	120	40.66	120
09	9,00. R/L .0,73.1,2	9	0,73	1,2	3,6	0,6	0,7	5,5	6,2	39.66	173	39.66	173
	9,00. R/L .0,83.1,3	9	0,83	1,3	3,6	0,7	0,8	5,5	6,2	39.66	183	39.66	183
	9,00. R/L .0,93.1,5	9	0,93	1,5	3,6	0,8	0,9	5,5	6,2	39.66	193	39.66	193
	9,00. R/L .1,00.1,8	9	1,00	1,8	3,6			5,5	6,2	39.66	210	39.66	210
	9,00. R/L .1,20.1,8	9	1,20	1,8	3,6	1,0	1,1	5,5	6,2	39.66	212	39.66	212
	9,00. R/L .1,40.1,8	9	1,40	1,8	3,6	1,2	1,3	5,5	6,2	39.66	214	39.66	214
	9,00. R/L .1,50.1,8	9	1,50	1,8	3,6			5,5	6,2	39.66	215	39.66	215
	9,00. R/L .1,70.1,8	9	1,70	1,8	3,6	1,5	1,6	5,5	6,2	39.66	217	39.66	217
	9,00. R/L .2,00.1,8	9	2,00	1,8	3,6			5,5	6,2	39.66	220	39.66	220
11	11,00. R/L .0,73.1,2	11	0,73	1,2	4,2	0,6	0,7	6,7	8,0	40.66	373	40.66	373
	11,00. R/L .0,83.1,3	11	0,83	1,3	4,2	0,7	0,8	6,7	8,0	40.66	383	40.66	383
	11,00. R .0,93.1,5	11	0,93	1,5	4,2	0,9	0,9	6,7	8,0			40.66	393
	11,00. L .0,93.1,5	11	0,93	1,5	4,2	0,8	0,9	6,7	8,0	40.66	393		
	11,00. R/L .1,00.2,3	11	1,00	2,3	4,2			6,7	8,0	40.66	310	40.66	310
	11,00. R/L .1,20.2,3	11	1,20	2,3	4,2	1,0	1,1	6,7	8,0	40.66	312	40.66	312
	11,00. R/L .1,40.2,3	11	1,40	2,3	4,2	1,2	1,3	6,7	8,0	40.66	314	40.66	314
	11,00. R/L .1,50.2,3	11	1,50	2,3	4,2			6,7	8,0	40.66	315	40.66	315
	11,00. R/L .1,70.2,3	11	1,70	2,3	4,2	1,5	1,6	6,7	8,0	40.66	317	40.66	317
14	14,00. R/L .0,73.1,2	14	0,73	1,2	5,3	0,6	0,7	9,0	9,0	40.66	573	40.66	573
	14,00. R/L .0,83.1,3	14	0,83	1,3	5,3	0,7	0,8	9,0	9,0	40.66	583	40.66	583
	14,00. R/L .0,93.1,5	14	0,93	1,5	5,3	0,8	0,9	9,0	9,0	40.66	593	40.66	593
	14,00. R/L .1,20.4,0	14	1,20	4,0	5,3	1,0	1,1	9,0	9,0	40.66	512	40.66	512
	14,00. R/L .1,40.4,0	14	1,40	4,0	5,3	1,2	1,3	9,0	9,0	40.66	514	40.66	514
	14,00. R/L .1,50.4,0	14	1,50	4,0	5,3			9,0	9,0	40.66	515	40.66	515
	14,00. R/L .1,70.4,0	14	1,70	4,0	5,3	1,5	1,6	9,0	9,0	40.66	517	40.66	517
	14,00. R/L .2,00.4,0	14	2,00	4,0	5,3			9,0	9,0	40.66	520	40.66	520
	14,00. R/L .2,50.4,0	14	2,50	4,0	5,3			9,0	9,0	40.66	525	40.66	525
16	16,00. R/L .0,73.1,2	16	0,73	1,2	5,4	0,6	0,7	10,2	11,0	49.53	773	49.53	773
	16,00. R/L .0,83.1,3	16	0,83	1,3	5,4	0,7	0,8	10,2	11,0	49.53	783	49.53	783
	16,00. R/L .0,93.1,5	16	0,93	1,5	5,4	0,8	0,9	10,2	11,0	49.53	793	49.53	793
	16,00. R/L .1,20.4,3	16	1,20	4,3	5,4	1,0	1,1	10,2	11,0	44.73	712	44.73	712
	16,00. R/L .1,40.4,3	16	1,40	4,3	5,4	1,2	1,3	10,2	11,0	44.73	714	44.73	714
	16,00. R/L .1,50.4,3	16	1,50	4,3	5,4			10,2	11,0	44.73	715	44.73	715
	16,00. R/L .1,70.4,3	16	1,70	4,3	5,4	1,5	1,6	10,2	11,0	44.73	717	44.73	717
	16,00. R/L .2,00.4,3	16	2,00	4,3	5,4			10,2	11,0	44.73	720	44.73	720
	16,00. R/L .2,50.4,3	16	2,50	4,3	5,4			10,2	11,0	44.73	725	44.73	725
P	16,00. R/L .3,00.4,3	16	3,00	4,3	5,4			10,2	11,0	44.73	730	44.73	730
	16,00. R/L .3,50.4,3	16	3,50	4,3	5,4			10,2	11,0	44.73	735	44.73	735
	16,00. R/L .4,00.4,3	16	4,00	4,3	5,4			10,2	11,0	44.73	740	44.73	740
M													
K													
N													
S													
H													
O													

MiniCut – Grooving insert

▲ large groove depth (T_{max} 5.5 mm)

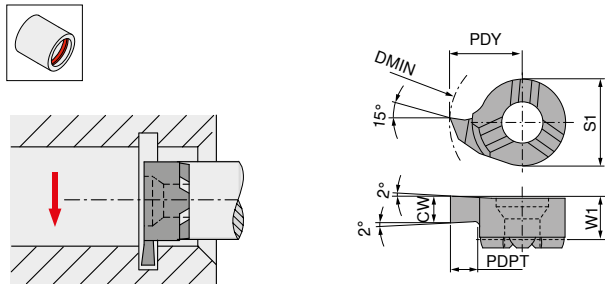

Illustrations show right-hand versions

Size	ISO designation	DMIN mm	CW ^{+0.03} mm	PDPT mm	W1 mm	PDY mm	S1 mm
14	14,00. R/L .1,50.5,5	16	1.5	5.5	5.2	10.5	9
	14,00. R/L .2,00.5,5	16	2.0	5.5	5.2	10.5	9
	14,00. R/L .2,50.5,5	16	2.5	5.5	5.2	10.5	9
	14,00. R/L .3,00.5,5	16	3.0	5.5	5.2	10.5	9

	Left-hand 73 372 ...	Right-hand 73 370 ...
	£ Y5	£ Y5
P	47.21 715	47.21 715
M	47.21 720	47.21 720
K	47.21 725	47.21 725
N	47.21 730	47.21 730
S		
H		
O		

→ v_c Page 59

MiniCut – Grooving insert

▲ large groove depth (T_{max} 6.5 mm)

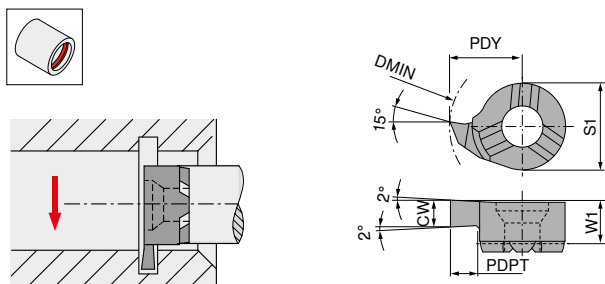

Illustrations show right-hand versions

Size	ISO designation	DMIN mm	CW ^{+0.03} mm	PDPT mm	W1 mm	PDY mm	S1 mm
14	14,00. R/L .1,50.6,5	17	1.5	6.5	5.2	11.5	9
	14,00. R/L .2,00.6,5	17	2.0	6.5	5.2	11.5	9
	14,00. R/L .2,50.6,5	17	2.5	6.5	5.2	11.5	9
	14,00. R/L .3,00.6,5	17	3.0	6.5	5.2	11.5	9

	Left-hand 73 384 ...	Right-hand 73 382 ...
	£ Y5	£ Y5
P	47.21 515	47.21 515
M	47.21 520	47.21 520
K	47.21 525	47.21 525
N	47.21 530	47.21 530
S		
H		
O		

→ v_c Page 59

MiniCut – Internal undercut insert

▲ CDX = ap_{max}

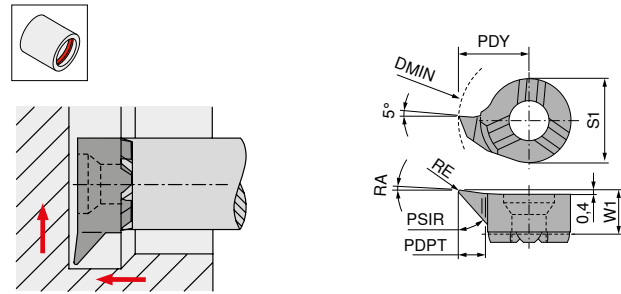

CWX500

CWX500



Illustrations show right-hand versions

Size	ISO designation	DMIN mm	PDPT mm	W1 mm	PDY mm	S1 mm	RE mm	CDX mm	PSIR °	RA °	Left-hand		Right-hand	
											73 328 ...	73 326 ...	73 328 ...	73 326 ...
08	8,00. R/L .30°:1,0	7.8	1.0	3.5	4.65	6.0	0.2	0.4	30	3	£ Y5 54.35	010	£ Y5 54.35	010
	8,00. R/L .47°:1,2	7.8	1.2	3.5	4.65	6.0	0.2	0.4	47	3	47.21	012	47.21	012
09	9,00. R/L .47°:1,5	9.0	1.5	3.6	5.50	6.2	0.2	0.5	47	3	43.78	115	43.78	115
11	11,00. R/L .30°:2,3	11.0	2.3	4.2	6.70	8.0	0.2	0.6	30	3	53.08	423	53.08	423
	11,00. R/L .47°:2,3	11.0	2.3	4.2	6.70	8.0	0.2	0.6	47	3	45.97	323	45.97	323
14	13,70. R/L .47°:3,0	13.7	3.0	5.3	8.70	9.0	0.2	0.8	47	3	47.21	530	47.21	530
	13,70. R/L .30°:4,0	13.7	4.0	5.3	8.70	9.0	0.2	0.8	30	3	54.35	540	54.35	540
16	15,80. R/L .30°:4,3	15.8	4.3	5.4	10.20	11.0	0.2	1.0	30	3	52.75	744	52.75	744
P											●		●	
M											●		●	
K											●		●	
N											●		●	
S											●		●	
H											●		●	
O											●		●	

→ v. Page 59

MiniCut – Full radius grooving and turning insert

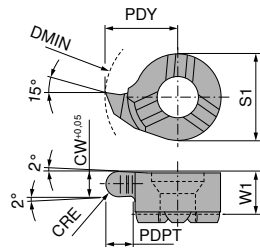
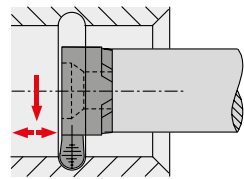
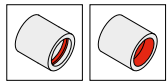

Illustrations show right-hand versions

Size	ISO designation	DMIN mm	CW mm	PDPT mm	W1 mm	PDY mm	S1 mm	CRE mm	Left-hand		Right-hand	
									73 320 ...	73 318 ...	73 320 ...	73 318 ...
									£		£	
									Y5		Y5	
08	8,00. R/L .0,80,1,0	8	0,8	1,0	3,3	4,8	6,0	0,4	50.69	008	50.69	008
	8,00. R/L .1,20,1,0	8	1,2	1,0	3,3	4,8	6,0	0,6	50.69	012	50.69	012
	8,00. R/L .1,80,1,0	8	1,8	1,0	3,3	4,8	6,0	0,9	50.69	018	50.69	018
	8,00. R/L .2,00,1,0	8	2,0	1,0	3,3	4,8	6,0	1,0	46.97	020	46.97	020
09	9,00. R/L .0,80,1,6	9	0,8	1,6	3,6	5,5	6,2	0,4	48.66	108	48.66	108
	9,00. R/L .1,20,1,6	9	1,2	1,6	3,6	5,5	6,2	0,6	48.66	112	48.66	112
	9,00. R/L .1,80,1,6	9	1,8	1,6	3,6	5,5	6,2	0,9	48.66	118	48.66	118
	9,00. R/L .2,00,1,6	9	2,0	1,6	3,6	5,5	6,2	1,0	48.66	120	48.66	120
11	11,00. R/L .0,80,2,3	11	0,8	2,3	4,2	6,7	8,0	0,4	51.31	308	51.31	308
	11,00. R/L .1,20,2,3	11	1,2	2,3	4,2	6,7	8,0	0,6	51.31	312	51.31	312
	11,00. R/L .1,60,2,3	11	1,6	2,3	4,2	6,7	8,0	0,8	48.66	316	48.66	316
	11,00. R/L .1,80,2,3	11	1,8	2,3	4,2	6,7	8,0	0,9	51.31	318	51.31	318
	11,00. R/L .2,00,2,3	11	2,0	2,3	4,2	6,7	8,0	1,0	51.31	320	51.31	320
	11,00. R/L .2,40,2,3	11	2,4	2,3	4,2	6,7	8,0	1,2	48.66	324	48.66	324
	11,00. R/L .3,00,2,3	11	3,0	2,3	4,2	6,7	8,0	1,5	51.31	330	51.31	330
14	14,00. R/L .0,80,4,0	14	0,8	4,0	5,3	9,0	9,0	0,4	50.64	508	50.64	508
	14,00. R/L .1,20,4,0	14	1,2	4,0	5,3	9,0	9,0	0,6	54.32	512	54.32	512
	14,00. R/L .1,80,4,0	14	1,8	4,0	5,3	9,0	9,0	0,9	54.32	518	54.32	518
	14,00. R/L .2,00,4,0	14	2,0	4,0	5,3	9,0	9,0	1,0	54.32	520	54.32	520
	14,00. R/L .2,20,4,0	14	2,2	4,0	5,3	9,0	9,0	1,1	54.32	522	54.32	522
	14,00. R/L .3,00,4,0	14	3,0	4,0	5,3	9,0	9,0	1,5	54.32	530	54.32	530
16	16,00. R/L .1,60,4,3	16	1,6	4,3	5,4	10,2	11,0	0,8	52.01	716	52.01	716
	16,00. R/L .1,80,4,3	16	1,8	4,3	5,4	10,2	11,0	0,9	54.87	718	54.87	718
	16,00. R/L .2,00,4,3	16	2,0	4,3	5,4	10,2	11,0	1,0	52.01	720	52.01	720
	16,00. R/L .2,20,4,3	16	2,2	4,3	5,4	10,2	11,0	1,1	54.87	722	54.87	722
	16,00. R/L .2,40,4,3	16	2,4	4,3	5,4	10,2	11,0	1,2	52.01	724	52.01	724
	16,00. R/L .3,00,4,3	16	3,0	4,3	5,4	10,2	11,0	1,5	54.87	730	54.87	730
	16,00. R/L .3,20,4,3	16	3,2	4,3	5,4	10,2	11,0	1,6	52.01	732	52.01	732
	16,00. R/L .4,00,4,3	16	4,0	4,3	5,4	10,2	11,0	2,0	54.87	740	54.87	740
P										●		●
M										●		●
K										●		●
N										●		●
S										●		●
H										●		●
O										●		●

→ v_c Page 59

MiniCut – Threading insert (Partial profile)

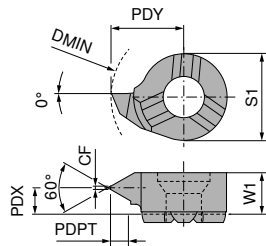
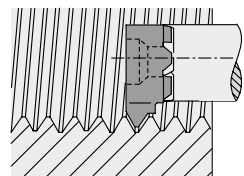
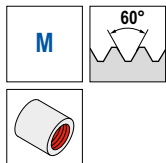

Illustrations show right-hand versions

Size	ISO designation	DMIN mm	TP mm	CF mm	PDPT mm	W1 mm	PDX mm	PDY mm	S1 mm	Left-hand		Right-hand	
										73 344 ...	73 342 ...	£	£
08	8,00. R/L .0,5/0,75.60°	8	0,5 - 0,75	0,06	0,43	3,50	2,7	4,8	6,0	54.87	012	54.87	012
	8,00. R/L .1,0/1,25.60°	8	1,0 - 1,25	0,12	0,70	3,50	2,7	4,8	6,0	54.87	014	54.87	014
	8,00. R/L .1,5/1,75.60°	8	1,5 - 1,75	0,18	0,95	3,50	2,5	4,8	6,0	54.87	010	54.87	010
09	9,00. R/L .0,5/0,75.60°	9	0,5 - 0,75	0,06	0,27	3,55	3,2	5,5	6,2	52.01	112	52.01	112
	9,00. R/L .1,0/1,25.60°	9	1,0 - 1,25	0,12	0,54	3,55	3,0	5,5	6,2	52.01	114	52.01	114
	9,00. R/L .1,5/1,75.60°	9	1,5 - 1,75	0,18	0,81	3,55	2,8	5,5	6,2	52.01	116	52.01	116
	9,00. R/L .1,75/2,0.60°	9	1,75 - 2,0	0,20	0,95	3,55	2,6	5,5	6,2	52.01	118	52.01	118
	9,00. R/L .2,0/2,5.60°	9	2,0 - 2,5	0,25	1,08	3,55	2,5	5,5	6,2	52.01	120	52.01	120
	9,00. R/L .2,5/3,0.60°	9	2,5 - 3,0	0,31	1,35	3,55	2,1	5,5	6,2	52.01	122	52.01	122
11	11,00. R/L .0,5/0,75.60°	11	0,5 - 0,75	0,06	0,75	4,30	3,5	6,7	8,0	54.87	312	54.87	312
	11,00. R/L .1,0/1,25.60°	11	1,0 - 1,25	0,12	0,55	4,30	3,5	6,7	8,0	54.87	314	54.87	314
	11,00. R/L .1,5/1,75.60°	11	1,5 - 1,75	0,18	0,81	4,30	3,5	6,7	8,0	54.87	316	54.87	316
	11,00. R/L .2,0/2,5.60°	11	2,0 - 2,5	0,25	1,08	4,30	3,0	6,7	8,0	54.87	310	54.87	310
	11,00. R/L .2,5/3,0.60°	11	2,5 - 3,0	0,31	1,35	4,30	3,0	6,7	8,0	54.87	320	54.87	320
14	14,00. R/L .1,0/1,25.60°	14	1,0 - 1,25	0,12	0,55	5,40	4,7	9,0	9,0	54.87	512	54.87	512
	14,00. R/L .1,5/1,75.60°	14	1,5 - 1,75	0,18	0,81	5,40	4,5	9,0	9,0	54.87	514	54.87	514
	14,00. R/L .2,0/2,5.60°	14	2,0 - 2,5	0,25	1,08	5,40	4,2	9,0	9,0	54.87	510	54.87	510
	14,00. R/L .2,5/3,0.60°	14	2,5 - 3,0	0,31	1,35	5,40	4,7	9,0	9,0	54.87	520	54.87	520
16	16,00. R/L .1,0/1,25.60°	16	1,0 - 1,25	0,12	0,55	5,50	4,7	10,2	11,0	54.87	712	54.87	712
	16,00. R/L .1,5/1,75.60°	16	1,5 - 1,75	0,18	0,81	5,50	4,5	10,2	11,0	54.87	714	54.87	714
	16,00. R/L .2,0/2,5.60°	16	2,0 - 2,5	0,25	1,08	5,50	4,2	10,2	11,0	54.87	716	54.87	716
	16,00. R/L .2,5/3,0.60°	16	2,5 - 3,0	0,31	1,35	5,50	4,2	10,2	11,0	54.87	710	54.87	710
P										●		●	
M										●		●	
K										●		●	
N										●		●	
S										●		●	
H										●		●	
O										●		●	

→ v, Page 59

MiniCut – Threading insert (Full profile)

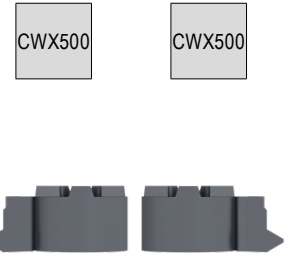
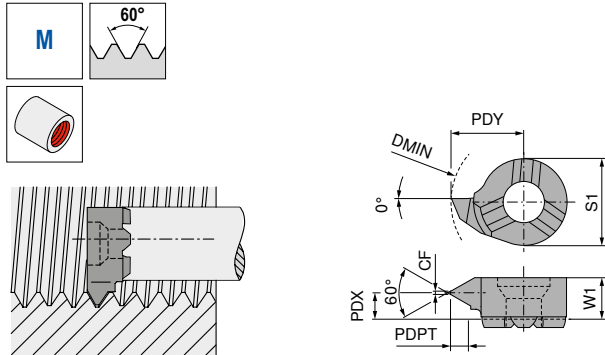

Illustrations show right-hand versions

Size	ISO designation	DMIN mm	TP mm	CF mm	PDPT mm	W1 mm	PDX mm	PDY mm	S1 mm	Left-hand		Right-hand	
										73 348 ...	73 346 ...	£	£
09	9,00. R/L .0,5.60°	9	0.50	0.06	0.27	3.55	3.25	5.5	6.2	57.97	405	57.97	405
	9,00. R/L .1,0.60°	9	1.00	0.12	0.54	3.55	3.00	5.5	6.2	57.97	410	57.97	410
	9,00. R/L .1,5.60°	9	1.50	0.18	0.81	3.55	2.80	5.5	6.2	57.97	415	57.97	415
	9,00. R/L .1,75.60°	9	1.75	0.20	0.95	3.55	2.70	5.5	6.2	57.97	418	57.97	418
	9,00. R/L .2,0.60°	9	2.00	0.25	1.08	3.55	2.60	5.5	6.2	57.97	420	57.97	420
	9,00. R/L .2,5.60°	9	2.50	0.31	1.35	3.55	2.50	5.5	6.2	57.97	425	57.97	425
	9,00. R/L .3,0.60°	9	3.00	0.37	1.62	3.55	2.20	5.5	6.2	57.97	430	57.97	430
11	11,00. R/L .1,0.60°	11	1.00	0.12	0.54	4.30	3.50	6.7	8.0	62.25	314	62.25	314
	11,00. R/L .1,5.60°	11	1.50	0.18	0.81	4.30	3.50	6.7	8.0	61.26	316	62.25	316
	11,00. R/L .2,0.60°	11	2.00	0.25	1.08	4.30	3.20	6.7	8.0	62.25	310	62.25	310
	11,00. R/L .2,5.60°	11	2.50	0.31	1.35	4.30	3.00	6.7	8.0	62.25	320	62.25	320
	11,00. R/L .3,0.60°	11	3.00	0.37	1.62	4.30	2.90	6.7	8.0	62.25	330	62.25	330
14	14,00. R/L .0,5.60°	14	0.50	0.06	0.27	5.40	3.50	9.0	9.0	63.03	510	63.03	510
	14,00. R/L .1,0.60°	14	1.00	0.12	0.54	5.40	3.50	9.0	9.0	57.37	512	57.37	512
	14,00. R/L .1,5.60°	14	1.50	0.18	0.81	5.40	3.30	9.0	9.0	57.37	514	57.37	514
	14,00. R/L .2,0.60°	14	2.00	0.25	1.08	5.40	4.20	9.0	9.0	57.37	610	57.37	610
	14,00. R/L .2,5.60°	14	2.50	0.31	1.35	5.40	4.70	9.0	9.0	57.37	520	57.37	520
16	16,00. R/L .1,0.60°	16	1.00	0.12	0.54	5.50	4.70	10.2	11.0	69.33	712	69.33	712
	16,00. R/L .1,5.60°	16	1.50	0.18	0.81	5.50	4.50	10.2	11.0	69.33	714	69.33	714
	16,00. R/L .2,0.60°	16	2.00	0.25	1.08	5.50	4.20	10.2	11.0	69.33	716	69.33	716
	16,00. R/L .2,5.60°	16	2.50	0.31	1.35	5.50	4.20	10.2	11.0	69.33	710	69.33	710
	16,00. R/L .3,0.60°	16	3.00	0.37	1.62	5.50	4.00	10.2	11.0	69.33	720	69.33	720
	16,00. R/L .3,5.60°	16	3.50	0.43	1.89	5.50	3.80	10.2	11.0	69.33	730	69.33	730
	16,00. R/L .4,0.60°	16	4.00	0.50	2.16	5.50	3.60	10.2	11.0	69.33	740	69.33	740
P											•		•
M											•		•
K											•		•
N											•		•
S											•		•
H											•		•
O											•		•

→ v_c Page 59

MiniCut – Threading insert (Full profile)

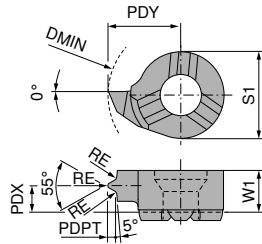
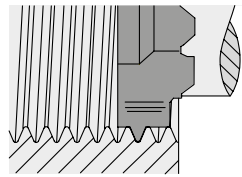
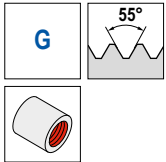

Illustrations show right-hand versions

Size	ISO designation	DMIN mm	TP mm	TPI 1/"	PDPT mm	W1 mm	PDX mm	PDY mm	S1 mm	RE mm	Left-hand		Right-hand	
											73 352 ...	73 350 ...		
11	11,00. R/L .1,814.55°	11	1.814	14	1.16	4.30	3.0	6.7	8	0.24	£ Y5 80.78	306	£ Y5 80.78	306
	11,00. R/L .1,337.55°	11	1.337	19	0.85	4.30	2.7	6.7	8	0.18	80.78	304	80.78	304
14	14,00. R/L .1,814.55°	14	1.814	14	1.16	5.35	3.6	9.0	9	0.24	79.71	506	79.71	506
	14,00. R/L .1,337.55°	14	1.337	19	0.85	5.35	3.8	9.0	9	0.18	79.71	504	79.71	504
16	16,00. R/L .2,309.55°	16	2.309	11	1.48	5.50	3.5	10.2	11	0.31	87.95	708	87.95	708
	16,00. R/L .1,814.55°	16	1.814	14	1.16	5.50	3.9	10.2	11	0.24	87.95	706	87.95	706
P											•		•	
M											•		•	
K											•		•	
N											•		•	
S											•		•	
H											•		•	
O											•		•	

→ v_c Page 59

MiniCut – Threading insert (Partial profile)

▲ Trapezoidal thread DIN 103

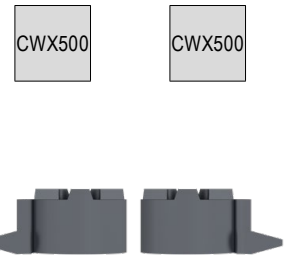
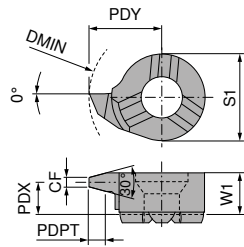
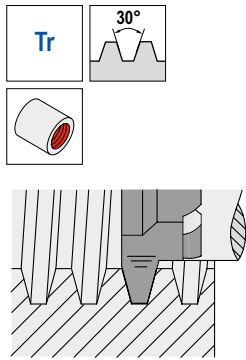

Illustrations show right-hand versions

Size	ISO designation	DMIN mm	TP mm	CF mm	PDPT mm	W1 mm	PDX mm	PDY mm	S1 mm	Left-hand		Right-hand	
										73 356 ...	73 354 ...	£	£
09	9,00. R/L .1,5.30°	9	1.5	0.47	0.90	3.55	3.00	5.5	6.2	53.54	415	53.54	415
	9,00. R/L .2,0.30°	9	2.0	0.60	1.25	3.55	2.85	5.5	6.2	53.54	420	53.54	420
	9,00. R/L .3,0.30°	9	3.0	0.96	1.75	3.55	2.25	5.5	6.2	53.54	430	53.54	430
	9,00. R/L .4,0.30°	10	4.0	1.33	2.25	3.55	2.25	5.5	6.2	53.54	440	53.54	440
11	11,00. R/L .1,5.30°	11	1.5	0.47	0.90	4.30	3.70	6.7	8.0	56.66	315	56.66	315
	11,00. R/L .2,0.30°	11	2.0	0.60	1.25	4.30	3.50	6.7	8.0	56.66	320	56.66	320
	11,00. R/L .3,0.30°	11	3.0	0.96	1.75	4.30	3.20	6.7	8.0	56.66	330	56.66	330
	11,00. R/L .4,0.30°	11	4.0	1.33	2.25	3.95	2.60	6.7	8.0	54.14	340	54.14	340
14	14,00. R/L .2,0.30°	14	2.0	0.60	1.25	5.30	4.30	9.0	9.0	56.83	520	56.83	520
	14,00. R/L .3,0.30°	14	3.0	0.96	1.75	5.30	4.00	9.0	9.0	56.83	530	56.83	530
	14,00. R/L .4,0.30°	14	4.0	1.33	2.25	5.30	3.60	9.0	9.0	56.83	540	56.83	540
	14,00. R/L .5,0.30°	14	5.0	1.69	2.75	5.30	3.30	9.0	9.0	56.83	550	56.83	550
16	16,00. R/L .2,0.30°	16	2.0	0.60	1.25	5.50	4.50	9.7	11.0	65.69	720	65.69	720
	16,00. R/L .3,0.30°	16	3.0	0.96	1.75	5.50	4.30	9.7	11.0	65.69	730	65.69	730
	16,00. R/L .4,0.30°	16	4.0	1.33	2.25	5.50	4.00	9.7	11.0	65.69	740	65.69	740
	16,00. R/L .5,0.30°	16	5.0	1.69	2.75	5.50	3.55	9.7	11.0	61.41	750	61.41	750
	16,00. R/L .6,0.30°	16	6.0	1.92	3.50	5.50	3.30	10.2	11.0	57.43	760	57.43	760
P											●	●	
M											●	●	
K											●	●	
N											●	●	
S											●	●	
H											●	●	
O											●	●	

→ v_c Page 59

MiniCut – Axial grooving insert

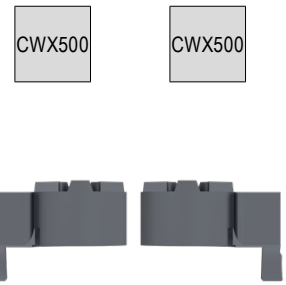
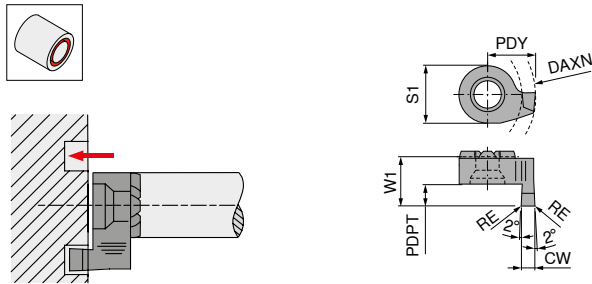

Illustrations show right-hand versions

Size	ISO designation	DAXN mm	CW mm	PDPT mm	W1 mm	PDY mm	RE mm	S1 mm
14	14,00. R/L .1,0,1,5	14	1.0	1.5	8.3	9		9
	14,00. R/L .1,5,2,5	14	1.5	2.5	8.3	9	0.2	9
	14,00. R/L .2,0,3,0	14	2.0	3.0	8.3	9	0.2	9
	14,00. R/L .2,0,5,0	14	2.0	5.0	10.3	9	0.2	9
	14,00. R/L .2,5,3,0	14	2.5	3.0	8.3	9	0.2	9
	14,00. R/L .2,5,5,0	14	2.5	5.0	10.3	9	0.2	9
	14,00. R/L .3,0,3,0	14	3.0	3.0	8.3	9	0.2	9
	14,00. R/L .3,0,5,0	14	3.0	5.0	10.3	9	0.2	9

Left-hand		Right-hand	
73 364 ...		73 362 ...	
£		£	
Y5		Y5	
44.21	510	44.21	510
44.21	515	44.21	515
44.21	520	44.21	520
51.31	620	51.31	620
44.21	525	44.21	525
51.31	625	51.31	625
44.21	530	44.21	530
51.31	630	51.31	630

P	•	•
M	•	•
K	•	•
N	•	•
S	•	•
H	•	•
O	•	•

→ v_c Page 59

MiniCut – Full radius axial grooving insert

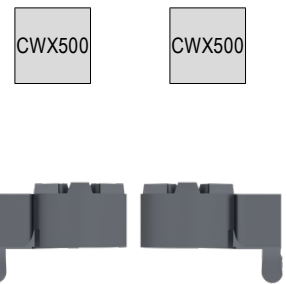
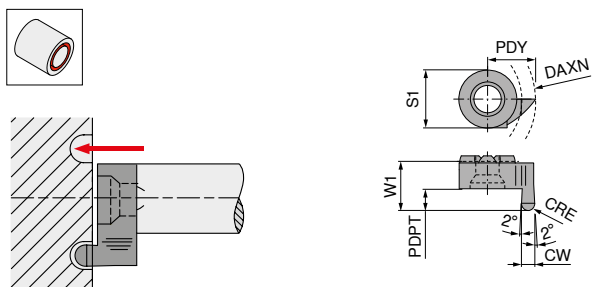

Illustrations show right-hand versions

Size	ISO designation	DAXN mm	CW mm	PDPT mm	W1 mm	PDY mm	CRE mm	S1 mm
14	14,00. R/L .1,0,1,5	14	1.0	1.5	8.3	9	0.5	9
	14,00. R/L .1,6,2,5	14	1.6	2.5	8.3	9	0.8	9
	14,00. R/L .2,0,3,0	14	2.0	3.0	8.3	9	1.0	9
	14,00. R/L .2,5,3,0	14	2.5	3.0	8.3	9	1.2	9
	14,00. R/L .3,0,3,0	14	3.0	3.0	8.3	9	1.5	9

Left-hand		Right-hand	
73 376 ...		73 374 ...	
£		£	
Y5		Y5	
51.10	510	51.10	510
51.10	516	51.10	516
51.10	520	51.10	520
51.10	525	51.10	525
51.10	530	51.10	530

P	•	•
M	•	•
K	•	•
N	•	•
S	•	•
H	•	•
O	•	•

→ v_c Page 59

MiniCut – Axial grooving insert over a spigot

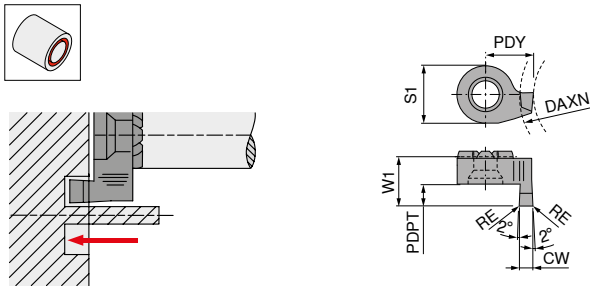

Illustrations show right-hand versions

Size	ISO designation	DAXN mm	CW mm	PDPT mm	W1 mm	PDY mm	RE mm	S1 mm	Left-hand		Right-hand	
									73 360 ...	73 358 ...	73 360 ...	73 358 ...
									£ Y5		£ Y5	
14	14/12. R/L .1,0.1,5	12	1.0	1.5	8.3	7.0		9	45.97	310	45.97	310
	14/12. R/L .1,5.2,5	12	1.5	2.5	8.3	7.5	0.2	9	47.06	315	47.06	315
	14/12. R/L .2,0.3,0	12	2.0	3.0	8.3	8.0	0.2	9	47.06	320	47.06	320
	14/12. R/L .2,0.5,0	12	2.0	5.0	10.3	8.0	0.2	9	54.86	420	54.86	420
	14/12. R/L .2,5.3,0	12	2.5	3.0	8.3	8.5	0.2	9	47.06	325	47.06	325
	14/12. R/L .2,5.5,0	12	2.5	5.0	10.3	8.5	0.2	9	54.86	425	54.86	425
	14/12. R/L .3,0.3,0	12	3.0	3.0	8.3	9.0	0.2	9	47.06	330	47.06	330
	14/12. R/L .3,0.5,0	12	3.0	5.0	10.3	9.0	0.2	9	54.86	430	54.86	430
P										•		•
M										•		•
K										•		•
N										•		•
S										•		•
H										•		•
O										•		•

→ v_c Page 59

MiniCut – Set

- ▲ Extensive range of size 9 inserts
- ▲ CWX 500

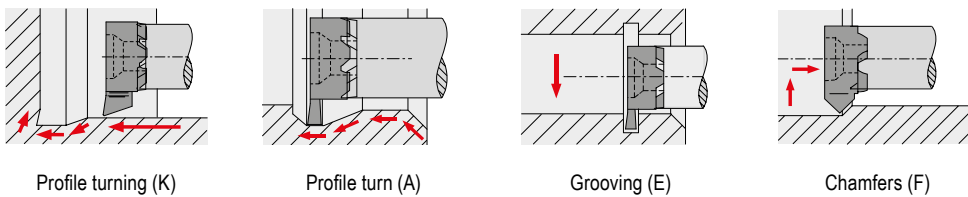

12

Size	Tool	Designation	Article no.	Bore Ø mm	Width mm	Grooving depth mm	Piece	fig.	73 528 ...	
									£ Y5	
09	Grooving insert	9,00. R .1,00.1,8	73 310 210	9	1,00	1,8	1	E		
	NC fine turning insert	9,00. R .2,00.2,0	73 314 120	9	2,0 +0,05	2,0	1	A		
	Profiling insert	9,00. R .3,60.10°	73 386 136	9	3,6		1	K		
	Profiling insert	9,00. R .3,60.20°	73 322 236	9	3,6		1	K	330.98	125
	Chamfering insert	9,00. R .45°.1,3	73 334 110	9		1,3	1	F		
	Tool holder	9,00/16.N.25.1,0	73 522 125				1			
	Tightening Key		70 950 105				1			

MiniCut – Steel Tool holder

Scope of supply:

Holder with clamping screw

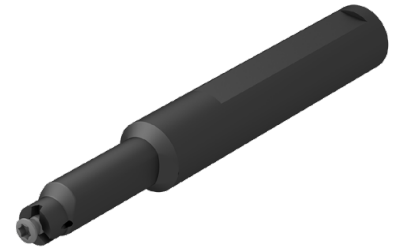
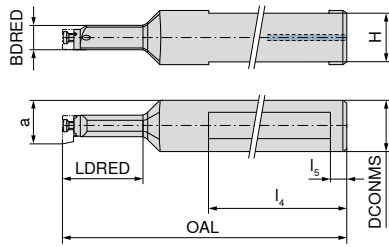

Size	Designation	a mm	DCONMS _{r7} mm	OAL mm	l ₄ mm	LDRED mm	BDRED mm	H mm	l ₅ mm	73 522 ...	
										£	
08	8,00/16.N.12.1,0	7.8	16	80	60	12		15.0	5	243.19	012
	8,00/16.N.22.1,0	7.8	16	90	60	22	7.0	15.0	5	279.05	122
09	9,00/16.N.14.1,8	8.6	16	95	60	14	7.4	15.0	5	220.56	014
	9,00/16.N.25.1,8	8.6	16	105	60	25	7.4	15.0	5	252.90	125
11	11,00/16.N.16.2,3	10.7	16	97	60	16		14.5	5	243.19	016
	11,00/16.N.29.2,3	10.7	16	110	60	29	9.5	14.5	5	279.05	129
14	14,00/16.N.18.4,0	13.8	16	100	60	18	11.0	14.5	5	279.05	018
	14,00/16.N.38.4,0	13.8	16	120	60	38	11.0	14.5	5	279.05	138
16	16,00/16.N.22.4,3	15.7	16	100	60	22		14.5	5	243.19	022
	16,00/16.N.42.4,3	15.7	16	120	60	42	13.5	14.5	5	279.05	142

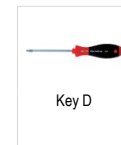

Spare parts

Size		80 950 ...		73 082 ...	
		£		£	
08	T08	13.09	110	9.08	002
09	T08	13.09	110	9.08	002
11	T10	15.30	112	9.08	003
14	T15	15.56	113	9.08	004
16	T20	16.66	114	9.08	005

MiniCut – Solid Carbide Tool holder – vibration damped

Scope of supply:

Holder with clamping screw

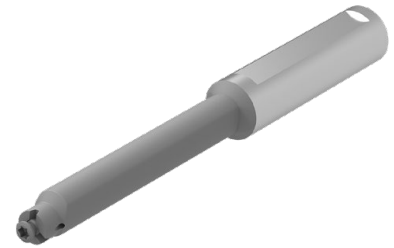
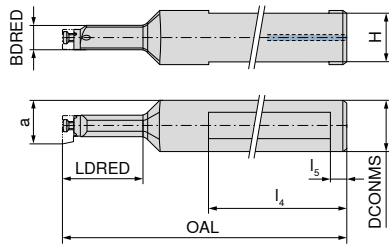

Size	Designation	a mm	DCONMS ₁₇ mm	OAL mm	l ₄ mm	LU mm	BDRED mm	H mm	l ₅ mm	73 520 ...	
										£	Y5
08	8,00/12.N.21.1,0 HM	7.8	12	80	50	22.60		11.0	5	393.42	021
	8,00/12.N.30.1,0 HM	7.8	12	90	54	30.80		11.0	5	425.44	030
	8,00/12.N.42.1,0 HM	7.8	12	100	54	42.80		11.0	5	500.52	042
	8,00/12.N.50.1,0 HM	7.8	12	115	48	51.60	7.2	11.0	5	571.81	050
09	9,00/12.N.22.1,0 HM	8.6	12	90	60	23.60	7.4	11.0	5	395.37	222
	9,00/12.N.30.2,0 HM	8.6	12	98	60	30.54	7.4	11.0	5	461.24	230
	9,00/12.N.42.3,0 HM	8.6	12	110	60	43.60	7.4	11.0	5	518.89	242
	9,00/12.N.56.4,0 HM	8.6	12	122	56	57.60	7.4	11.0	5	587.53	256
11	11,00/12.N.29.2,3 HM	10.7	12	95	60	26.40		10.5	5	393.42	129
	11,00/12.N.42.2,3 HM	10.7	12	110	56	42.50		10.5	5	425.44	142
	11,00/12.N.56.2,3 HM	10.7	12	120	56	57.60		10.5	5	500.52	156
	11,00/12.N.64.2,3 HM	10.7	12	130	56	65.60	9.5	10.5	5	571.81	164
14	14,00/12.N.34.4,0 HM	13.8	12	100	59	35.00	11.0	10.5	5	478.80	234
	14,00/12.N.45.4,0 HM	13.8	12	110	59	46.25	11.0	10.5	5	539.60	245
	14,00/12.N.64.4,0 HM	13.8	12	130	60	65.25	11.0	10.5	5	636.23	264
	14,00/16.N.34.4,0 HM	13.8	16	100	59	35.60	11.0	14.5	5	561.15	334
	14,00/16.N.45.4,0 HM	13.8	16	110	56	46.60	11.0	14.5	5	639.69	345
	14,00/16.N.64.4,0 HM	13.8	16	130	59	65.40	11.0	14.5	5	735.77	364
	14,00/16.N.75.4,0 HM	13.8	16	145	56	81.60	11.0	14.5	5	786.04	375
16	16,00/12.N.40.4,3 HM	15.7	12	130	60	41.25		10.5	5	507.58	440
	16,00/12.N.56.4,3 HM	15.7	12	130	60	57.25		10.5	5	539.60	456
	16,00/12.N.80.4,3 HM	15.7	12	150	60	81.06		10.5	5	636.23	480
	16,00/16.N.56.4,3 HM	15.7	16	130	60	57.60		14.5	5	639.69	556
	16,00/16.N.40.4,3 HM	15.7	16	130	60	41.60		14.5	5	618.34	540
	16,00/16.N.80.4,3 HM	15.7	16	150	60	81.60		14.5	5	735.77	580

12

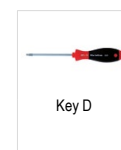

Key D



Clamping screw

Spare parts

Size	T	80 950 ...		73 082 ...		
		£	Y7	£	Y5	
08	T08	13.09	110	M2,6	9.08	002
09	T08	13.09	110	M2,6	9.08	002
11	T10	15.30	112	M3,5	9.08	003
14	T15	15.56	113	M4	9.08	004
16	T20	16.66	114	M5	9.08	005

MiniCut – HM – Flexoholder

Scope of supply:

Holder with clamping screw

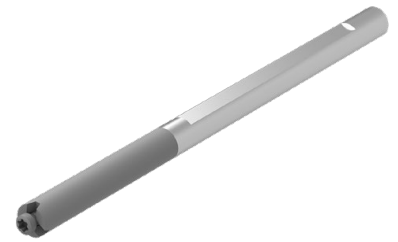
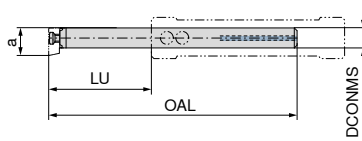

Size	Designation	DCONMS mm	OAL mm	LU mm	a mm		
08	8,0/6.N16/2	6	65	18	8		73 525 ...
	8,0/6.N40/4	6	103	40	8		£ Y5 557.34 818 634.20 840
11	11,0/8.N20/2	8	79	20	11		705.60 120 ¹⁾
	11,0/8.N50/4	8	129	50	11		801.69 150 ¹⁾

1) with thro' coolant

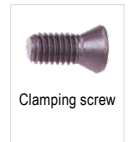
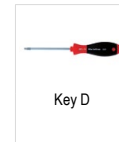

Spare parts

Size		£		£	
08	T08	13.09	110	9.08	002
11	T10	15.30	112	9.08	003

MiniCut – Base holder for solid carbide Flexoholder

Scope of supply:

Holder with clamping screw

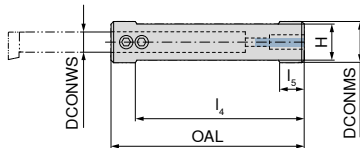

Size	Designation	DCONWS mm	DCONMS mm	H mm	OAL mm	l ₄ mm	l ₅ mm		
08	8/16.75	6	16	14	75	55	10		73 526 ...
	8/20.75	6	20	18	75	70	10		£ Y5 334.96 816 334.96 820
11	11/16.75	8	16	14	75	55	10		334.96 116
	11/20.75	8	20	18	75	70	10		334.96 120

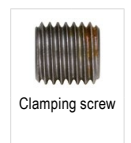

Spare parts for Article no.

		£		£	
73 526 816	SW2,5	2.83	175	5.84	010
73 526 820	SW2,5	2.83	175	5.84	010
73 526 116	SW2,5	2.83	175	5.84	009
73 526 120	SW2,5	2.83	175	5.84	010

MiniCut – Steel holder

▲ for axial machining

Scope of supply:

Holder with clamping screw

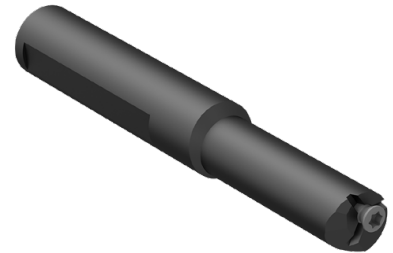
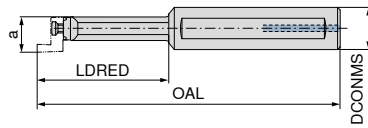

Size	Designation	a mm	DCONMS mm	OAL mm	LDRED mm	Left-hand		Right-hand	
						73 523 ...	73 524 ...	73 523 ...	73 524 ...
14	14,0/16. L .25.1,0	13.5	16	90	25	£ Y5 299.26	025	£ Y5 299.26	025
	14,0/16. R .25.1,0	13.5	16	90	25				
	14,0/16. L .45.1,0	13.5	16	110	45	£ 318.47	145	£ 318.47	145
	14,0/16. R .45.1,0	13.5	16	110	45				

Spare parts

Size	Key D	Clamping screw
14	80 950 ... £ Y7 15.56	73 082 ... £ Y5 9.08
	T15 113	M4 004

SlotCut – Inserts – DIN 138

▲ b₁ = Groove width

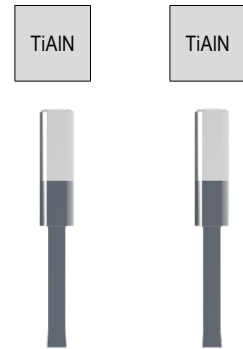
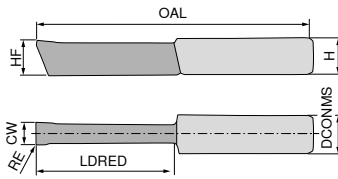

Designation	b ₁ P 9/US 9 mm	CW mm	HF mm	RE mm	OAL mm	LDRED mm	DMIN mm	DCONMS _{h6} mm	H mm	73 601 ...		73 602 ...	
										£		£	
NPU.0198.01.1	2	1.98	5.5	0.1	38	12.5	6	7	6.3	Y5		Y5	
NPU.0200.01.1	2	2.01	5.5	0.1	38	12.5	6	7	6.3	103.15	099	103.15	099
NPU.0298.01.1	3	2.98	6.2	0.1	38	12.5	7	7	6.3	103.15	100	103.15	100
NPU.0300.01.1	3	3.01	6.2	0.1	38	12.5	7	7	6.3	103.15	100	103.15	100
NPU.0398.01.1	4	3.98	6.2	0.1	40	15.0	7	7	6.3			90.50	101
NPU.0398.02.2	4	3.98	6.2	0.2	50	25.0	7	7	6.3			118.74	102
NPU.0400.01.1	4	4.01	6.2	0.1	40	15.0	7	7	6.3	90.50	101		
NPU.0400.02.1	4	4.01	6.2	0.2	40	15.0	7	7	6.3	90.50	102		
NPU.0400.02.2	4	4.01	6.2	0.2	50	25.0	7	7	6.3	118.74	103		
NPU.0498.02.2	5	4.98	5.8	0.2	50	25.0	7	7	6.3			118.74	103
NPU.0500.02.2	5	5.01	5.8	0.2	50	25.0	8	7	6.3	118.74	104		

Tolerance JS 9 for 73 601, Tolerance P 9 for 73 602

SlotCut – Toolholder for broaching inserts

Scope of supply:

Tool holder with clamping screw, without insert

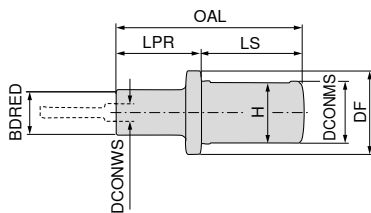

Designation	DCONWS mm	BDRED mm	DCONMS _{g6} mm	DF mm	OAL mm	LS mm	LPR mm	H mm	73 610 ...	
									£	
NHU.25	7	18	25	33	73	40	33	23	Y5	025
NHU.32	7	20	32	40	73	40	33	30	494.40	032
									518.08	

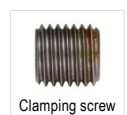

Spare parts

DCONMS	70 950 ...		73 082 ...	
	£		£	
25	2A/28	175	Y5	001
32	2.83	175	7.29	001
	2.83	175	7.29	001

SlotCut – Inserts – DIN 138

▲ b₁ = Groove width

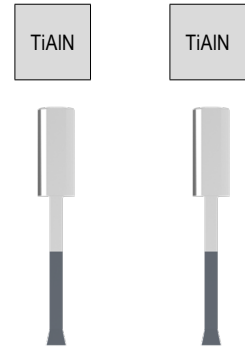
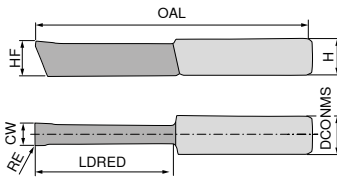

Designation	b ₁ JS9/9	CW	HF	RE	OAL	LDRED	DMIN	DCONMS ₉₆	H	73 607 ...		73 608 ...	
										£		£	
NP10.398.02.2	4	3.98	9	0.2	50	25	10	10	9.2	Y5		Y5	
NP10.398.02.3	4	3.98	9	0.2	66	41	10	10	9.2	144.78	101		
NP10.400.02.2	4	4.01	9	0.2	50	25	10	10	9.2	180.96	102		
NP10.400.02.3	4	4.01	9	0.2	66	41	10	10	9.2			144.78	101
NP10.498.02.2	5	4.98	9	0.2	50	25	10	10	9.2			180.96	102
NP10.498.02.3	5	4.98	9	0.2	66	41	10	10	9.2	144.78	103		
NP10.500.02.2	5	5.01	9	0.2	50	25	10	10	9.2	180.96	104		
NP10.500.02.3	5	5.01	9	0.2	66	41	10	10	9.2			144.78	103
												180.96	104

Tolerance **P 9** for 73 607, Tolerance **JS 9** for 73 608

SlotCut – Toolholder for Cutting Inserts

Scope of supply:

Tool holder with clamping screw, without insert

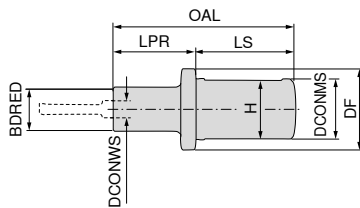

Designation	DCONWS	BDRED	DCONMS ₉₆	DF	OAL	LS	LPR	H	73 612 ...	
									£	
NH10.0025.1	10	20	25	33	73	40	33	23	Y5	
NH10.0032.1	10	20	32	40	73	40	33	30	562.78	025
									562.78	032

12

Spare parts	DCONMS	Key I	Grubscrew	70 950 ...	
				£	
25	SW3	2.83	176	M6x5,5	9.08 031
32	SW3	2.83	176	M6x5,5	9.08 031

SlotCut – Inserts – DIN 138

▲ b₁ = Groove width

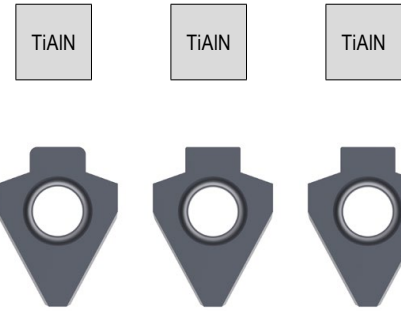
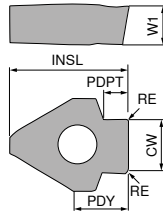

Designation	b ₁ P 9/JS 9/C 11 mm	CW mm	RE mm	PDY mm	INSL mm	PDPT mm	DMIN mm	W1 mm	clamping holder	73 603 ...		73 604 ...		73 605 ...	
										£ Y5		£ Y5		£ Y5	
NV15.0398.02	4	3.98	0.20	6.5	13.0	2.3	15	3.2	NHV 15					95.03	110
NV15.0401.02	4	4.01	0.20	6.5	13.0	2.3	15	3.2	NHV 15			95.03	110		
NV15.0410.050	4	4.10	0.50	6.5	13.0	2.2	15	3.2	NHV 15	95.03	108			95.03	111
NV15.0498.02	5	4.98	0.20	6.5	13.0	2.8	15	3.2	NHV 15					95.03	111
NV15.0501.02	5	5.01	0.20	6.5	13.0	2.8	15	3.2	NHV 15			95.03	111		
NV15.0510.050	5	5.10	0.50	6.5	13.0	2.5	15	3.2	NHV 15	95.03	109			95.03	112
NV15.0598.02	6	5.98	0.20	6.5	13.0	3.3	15	3.2	NHV 15					95.03	112
NV15.0601.02	6	6.01	0.20	6.5	13.0	3.3	15	3.2	NHV 15			95.03	112		
NV15.0612.085	6	6.12	0.85	6.5	13.0	2.6	15	3.2	NHV 15	95.03	110				
NPV.0498.02	5	4.98	0.20	8.0	17.3	2.7	22	5.3	NHV 22					92.31	100
NPV.0501.02	5	5.01	0.20	8.0	17.3	2.7	22	5.3	NHV 22			92.31	100		
NPV.0598.02	6	5.98	0.20	8.0	17.3	3.4	22	5.3	NHV 22					83.60	101
NPV.0601.02	6	6.01	0.20	8.0	17.3	3.4	22	5.3	NHV 22			83.60	101		
NPV.0612.085	6	6.12	0.85	8.0	17.3	2.6	22	5.3	NHV 22	83.60	101				
NPV.0713.085	7	7.13	0.85	8.0	17.3	3.3	22	5.3	NHV 22	83.60	102				
NPV.0798.02	8	7.98	0.20	8.0	17.3	4.1	22	5.3	NHV 22/30					83.60	102
NPV.0801.02	8	8.01	0.20	8.0	17.3	4.1	22	5.3	NHV 22/30			83.60	102		
NPV.0813.105	8	8.13	1.05	8.0	17.3	3.4	22	5.3	NHV 22/30	83.60	103				
NPV.0998.03	10	9.98	0.30	8.0	17.3	4.2	30	5.3	NHV 30					83.60	103
NPV.1001.03	10	10.01	0.30	8.0	17.3	4.2	30	5.3	NHV 30			83.60	103		
NPV.1013.105	10	10.13	1.05	10.9	20.2	4.2	40	5.3	NHV 38	83.60	104				
NPV.1197.03	12	11.97	0.30	10.9	20.2	5.7	40	5.3	NHV 38					92.31	104
NPV.1202.03	12	12.02	0.30	10.9	20.2	5.7	40	5.3	NHV 38			92.31	104		
NPV.1202.05	20	12.02	0.50	10.9	20.2	8.5	40	5.3	NHV 38			92.31	105		
NPV.1215.135	12	12.15	1.35	10.9	20.2	5.1	40	5.3	NHV 38	92.31	105				
NPV.1215.175	16	12.15	1.75	10.9	20.2	6.6	40	5.3	NHV 38	92.31	106				
NPV.1215.225	24	12.15	2.25	10.9	20.2	8.5	40	5.3	NHV 38	92.31	107				
NPV.1397.03	14	13.97	0.30	10.9	20.1	7.5	45	5.3	NHV 45					107.67	106
NPV.1402.03	14	14.02	0.30	10.9	20.1	7.5	45	5.3	NHV 45			107.67	106		
NPV.1597.03	16	15.97	0.30	10.9	20.1	7.5	45	5.3	NHV 45					107.67	107
NPV.1602.03	16	16.02	0.30	10.9	20.1	7.5	45	5.3	NHV 45			107.67	107		
NPV.1797.05	18	17.97	0.50	10.9	20.1	9.5	45	5.3	NHV 45					107.67	108
NPV.1802.05	18	18.02	0.50	10.9	20.1	9.5	45	5.3	NHV 45			107.67	108		
NPV.1997.05	20	19.97	0.50	10.9	20.1	10.0	45	5.3	NHV 45					107.67	109
NPV.2002.05	20	20.02	0.50	10.9	20.1	10.0	45	5.3	NHV 45			107.67	109		

Tolerance C 11 for 73 603, Tolerance JS 9 for 73 604, Tolerance P 9 for 73 605

SlotCut – Toolholder for inserts

Scope of supply:

Tool holder with clamping screw, without insert

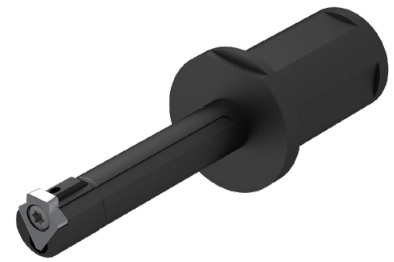
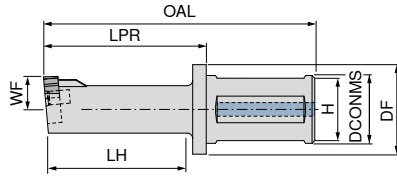

Designation	DCONMS _{g6} mm	DMIN mm	DF mm	OAL mm	LH mm	LPR mm	H mm	WF mm	73 613 ...	
NHV.15.1	25	15	33	75	25	35	23	8.4	£	025
NHV.15.2	25	15	33	90	40	50	23	8.4	Y5	483.21
NHV.15.3	25	15	33	110	60	70	23	8.4	Y7	529.87
										604.01

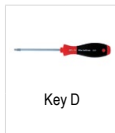

Spare parts

DCONMS

25	T15	£	113	M4x10	£	029
		Y7	15.56		Y5	12.36

SlotCut – Toolholder for inserts

Scope of supply:

Tool holder with clamping screw, without insert

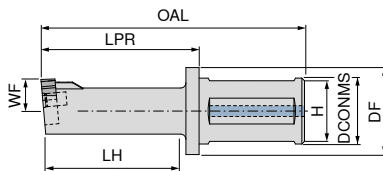

12

Designation	DCONMS _{g6} mm	DMIN mm	DF mm	OAL mm	LH mm	LPR mm	H mm	WF mm	73 611 ...	
NHV.22	25	22	33	100	50	60	23	12.0	£	025
NHV.30	32	30	45	100	50	60	30	16.5	Y5	463.59
NHV.30	32	30	45	125	75	85	30	16.5	Y7	463.59
NHV.38	32	38	45	100	50	60	30	22.0		528.43
NHV.38	32	38	45	125	75	85	30	22.0		528.43
NHV.45	40	45	55	175	105	115	38	24.0		966.39
NHV.45	40	45	55	120	50	60	38	24.0		713.84
NHV.45	40	45	55	225	155	165	38	24.0		1,089.95

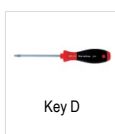

Spare parts

DCONMS

25	T20	£	114	M5x13	£	007
32	T20	Y7	16.66	M5x13	Y5	9.53
40	T20	Y7	16.66	M5x13	Y5	9.53

Material examples for cutting data tables

	Material sub-group	Index	Composition / Structure / Heat treatment	Tensile strength N/mm ² / HB / HRC	Material number	Material designation	Material number	Material designation
P	Unalloyed steel	P.1.1	< 0,15 % C Annealed	420 N/mm ² / 125 HB	1.0401	C15	1.1141	Ck15
		P.1.2	< 0,45 % C Annealed	640 N/mm ² / 190 HB	1.1191	C45E	1.0718	9SMnPb28
		P.1.3	< 0,45 % C Tempered	840 N/mm ² / 250 HB	1.1191	C45E	1.0535	C55
		P.1.4	< 0,75 % C Annealed	910 N/mm ² / 270 HB	1.1223	C60R	1.0535	C55
		P.1.5	< 0,75 % C Tempered	1010 N/mm ² / 300 HB	1.1223	C60R	1.0727	45S20
	Low-alloy steel	P.2.1	Annealed	610 N/mm ² / 180 HB	1.7131	16MnCr5	1.6587	17CrNiMo6
		P.2.2	Tempered	930 N/mm ² / 275 HB	1.7131	16MnCr5	1.6587	17CrNiMo6
		P.2.3	Tempered	1010 N/mm ² / 300 HB	1.7225	42CrMo4	1.3505	100Cr6
		P.2.4	Tempered	1200 N/mm ² / 375 HB	1.7225	42CrMo4	1.3505	100Cr6
	High-alloy steel and high-alloy tool steel	P.3.1	Annealed	680 N/mm ² / 200 HB	1.4021	X20Cr13	1.4034	X46Cr13
		P.3.2	Hardened and tempered	1100 N/mm ² / 300 HB	1.2343	X38CrMoV5-1	1.4034	X46Cr13
		P.3.3	Hardened and tempered	1300 N/mm ² / 400 HB	1.2343	X38CrMoV5-1	1.4034	X46Cr13
	Stainless steel	P.4.1	Ferritic / martensitic Annealed	680 N/mm ² / 200 HB	1.4016	X6Cr17	1.2316	X36CrMo16
		P.4.2	Martensitic Tempered	1010 N/mm ² / 300 HB	1.4112	X90CrMoV18	1.2316	X36CrMo16
M	Stainless steel	M.1.1	Austenitic / austenitic-ferritic Quenched	610 N/mm ² / 180 HB	1.4301	X5CrNi18-10	1.4571	X6CrNiMoTi17-12-2
		M.2.1	Austenitic Tempered	300 HB	1.4841	X15CrNiSi25-21	1.4539	X1NiCrMoCu25-20-5
		M.3.1	Austenitic / ferritic (Duplex)	780 N/mm ² / 230 HB	1.4462	X2CrNiMoN22-5-3	1.4501	X2CrNiMoCuWN25-7-4
K	Grey cast iron	K.1.1	Pearlitic / ferritic	350 N/mm ² / 180 HB	0.6010	GG-10	0.6025	GG-25
		K.1.2	Pearlitic (martensitic)	500 N/mm ² / 260 HB	0.6030	GG-30	0.6045	GG-45
	Spherulitic graphite cast iron	K.2.1	Ferritic	540 N/mm ² / 160 HB	0.7040	GGG-40	0.7060	GGG-60
		K.2.2	Pearlitic	845 N/mm ² / 250 HB	0.7070	GGG-70	0.7080	GGG-80
	Malleable iron	K.3.1	Ferritic	440 N/mm ² / 130 HB	0.8035	GTW-35-04	0.8045	GTW-45
		K.3.2	Pearlitic	780 N/mm ² / 230 HB	0.8165	GTS-65-02	0.8170	GTS-70-02
N	Aluminium wrought alloy	N.1.1	Non-hardenable	60 HB	3.0255	Al99,5	3.3315	AlMg1
		N.1.2	Hardenable Age-hardened	340 N/mm ² / 100 HB	3.1355	AlCuMg2	3.2315	AlMgSi1
	Cast aluminium alloy	N.2.1	≤ 12 % Si, non-hardenable	250 N/mm ² / 75 HB	3.2581	G-AlSi12	3.2163	G-AlSi9Cu3
		N.2.2	≤ 12 % Si, hardenable Age-hardened	300 N/mm ² / 90 HB	3.2134	G-AlSi5Cu1Mg	3.2373	G-AlSi9Mg
		N.2.3	> 12 % Si, non-hardenable	440 N/mm ² / 130 HB		G-AlSi17Cu4Mg		G-AlSi18CuNiMg
	Copper and copper alloys (bronze/brass)	N.3.1	Free-machining alloys, PB > 1 %	375 N/mm ² / 110 HB	2.0380	CuZn39Pb2 (Ms58)	2.0410	CuZn44Pb2
		N.3.2	CuZn, CuSnZn	300 N/mm ² / 90 HB	2.0331	CuZn15	2.4070	CuZn28Sn1As
		N.3.3	CuSn, lead-free copper and electrolytic copper	340 N/mm ² / 100 HB	2.0060	E-Cu57	2.0590	CuZn40Fe
	Magnesium alloys	N.4.1	Magnesium and magnesium alloys	70 HB	3.5612	MgAl6Zn	3.5312	MgAl3Zn
	S	Heat-resistant alloys	S.1.1	Fe - basis Annealed	680 N/mm ² / 200 HB	1.4864	X12NiCrSi 36-16	1.4865
S.1.2			Fe - basis Age-hardened	950 N/mm ² / 280 HB	1.4980	X6NiCrTiMoVB25-15-2	1.4876	X10NiCrAlTi32-20
S.2.1			Ni or Co basis Annealed	840 N/mm ² / 250 HB	2.4631	NiCr20TiAl (Nimonic80A)	3.4856	NiCr22Mo9Nb
S.2.2			Ni or Co basis Age-hardened	1180 N/mm ² / 350 HB	2.4668	NiCr19Nb5Mo3 (Inconel 718)	2.4955	NiFe25Cr20NbTi
S.2.3			Ni or Co basis Cast	1080 N/mm ² / 320 HB	2.4765	CoCr20W15Ni	1.3401	G-X120Mn12
Titanium alloys		S.3.1	Pure titanium	400 N/mm ²	3.7025	Ti99,8	3.7034	Ti99,7
		S.3.2	Alpha + beta alloys Age-hardened	1050 N/mm ² / 320 HB	3.7165	TiAl6V4	Ti-6246	Ti-6Al-2Sn-4Zr-6Mo
S.3.3	Beta alloys	1400 N/mm ² / 410 HB	Ti555.3	Ti-5Al-5V-5Mo-3Cr	R56410	Ti-10V-2Fe-3Al		
H	Hardened steel	H.1.1	Hardened and tempered	46–55 HRC				
		H.1.2	Hardened and tempered	56–60 HRC				
		H.1.3	Hardened and tempered	61–65 HRC				
		H.1.4	Hardened and tempered	66–70 HRC				
	Chilled iron	H.2.1	Cast	400 HB				
Hardened cast iron	H.3.1	Hardened and tempered	55 HRC					
O	Non-metal materials	O.1.1	Plastics, duroplastic	≤ 150 N/mm ²				
		O.1.2	Plastics, thermoplastic	≤ 100 N/mm ²				
		O.2.1	Aramid fibre-reinforced	≤ 1000 N/mm ²				
		O.2.2	Glass/carbon-fibre reinforced	≤ 1000 N/mm ²				
		O.3.1	Graphite					

* Tensile strength

Cutting data standard values

	UltraMini K10F uncoated	UltraMini TiN	UltraMini TiAlN	UltraMini TiAlN+	MiniCut CWX500	MiniCut CBN
Index	v_c in m/min					
P.1.1		90	110	110	160	
P.1.2		80	100	100	140	
P.1.3		60	80	80	140	
P.1.4		60	80	80	110	
P.1.5		60	60	60	100	
P.2.1		60	80	80	110	
P.2.2		60	60	60	100	
P.2.3		50	60	60	90	
P.2.4		50	60	60	80	
P.3.1		50	60	60	80	
P.3.2		30	50	50	70	
P.3.3		30	30	30	50	
P.4.1		60	70	70	100	
P.4.2		50	60	60	90	
M.1.1		60	80	80	80	
M.2.1		50	60	60	70	
M.3.1		40	50	50	60	
K.1.1		80	100	100	90	
K.1.2		60	70	70	100	
K.2.1		60	60	60	80	
K.2.2		50	60	60	70	
K.3.1		80	100	100	120	
K.3.2		70	80	80	100	
N.1.1	100	200	230	230	290	
N.1.2	100	180	220	220	280	
N.2.1	90	160	190	190	240	
N.2.2	70	140	170	170	200	
N.2.3	50	80	100	100	120	
N.3.1	80	140	170	170	210	
N.3.2	70	120	140	140	180	
N.3.3	50	100	120	120	130	
N.4.1	50	100	120	120	100	
S.1.1		30	50	50	50	
S.1.2		30	30	30	30	30
S.2.1		30	50	50	50	50
S.2.2		30	30	30	40	30
S.2.3			30	30	30	30
S.3.1		30	50	50	50	
S.3.2		20	30	30	40	
S.3.3			20	20	30	20
H.1.1		30	40	40	50	40
H.1.2			30	30	40	30
H.1.3				30		30
H.1.4						
H.2.1						
H.3.1		20	30	30	40	30
O.1.1	50	90	110	110	150	
O.1.2	50	100	120	120	150	
O.2.1		90	110	110	130	
O.2.2		60	80	80	100	
O.3.1	50	100	120	120	150	

	UltraMini	MiniCut
	f in mm/rev.	

Internal turning and profiling	0,02–0,05	0,03–0,10
Internal turning and profiling - hard turning	0,02–0,06	0,03–0,10
Internal turning	0,02–0,05	0,01–0,03
Back boring	0,02–0,04	0,03–0,10
Turning and chamfering	0,01–0,03	0,03–0,10
Pre-parting and chamfering	0,01–0,02	0,01–0,03
Groove turning	0,01–0,02	0,01–0,03
Internal Undercuts	0,01–0,03	0,03–0,08
Groove and profile turning	0,01–0,02	0,01–0,03
Axial grooving	0,02–0,05	0,02–0,05

 The cutting data is strongly influenced by external conditions, such as the stability of the tool and workpiece clamping, material and type of machine. The specified values represent guideline cutting data that can be adjusted by approx. ±20% according to the usage conditions.

Broaching – Recommendations for Correct Use

SlotCut

More and more often small and medium sized batch sizes are manufactured with precision grooves.

To directly machine such grooves in one set-up on one machine, it requires a special application of "Broaching" tools.

The SlotCut system can produce grooves with the most common groove tolerances.

To this end, there are four options. Two concepts are based on a solid carbide solution, which gives great success with small diameters.

For larger diameters, the concept with screw-on inserts is more suitable.

Broaching, on both lathes and machining centers is now economical, and provides highly accurate results in the shortest possible time.

Approximate values when broaching

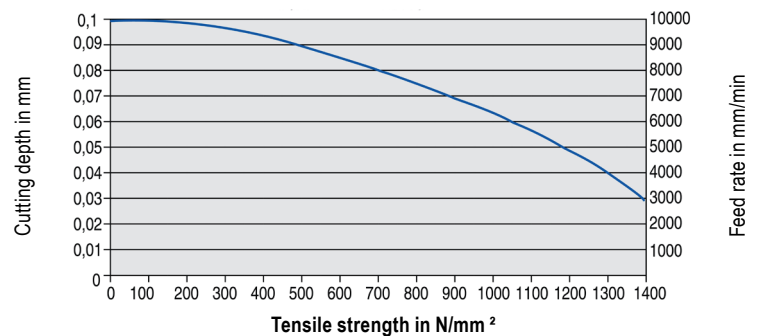

The data depends strongly on the conditions and represent only an approximate value, factors such as machine stability, application and material may require adjustment of the data upward or downward.



Tips for the User

- ▲ Avoid interrupted cuts.
- ▲ Lift the tool out of the groove when retracting.
- ▲ Where possible, orientate the part so the groove is at the top, so the chips fall away!
- ▲ Use coolant
This will increase tool life and surface quality.
- ▲ Ensure there is a relief at the end of the groove.
- ▲ Adjustment of the tool is essential, therefore the tool diameter must be considered.



Coatings

TiAlN+	<ul style="list-style-type: none"> ▲ TiAlN multilayer coating ▲ Maximum application temperature: 1000°C
TiN	<ul style="list-style-type: none"> ▲ TiN coating ▲ Maximum application temperature: 450°C
TiAlN	<ul style="list-style-type: none"> ▲ TiAlN multilayer coating ▲ Maximum application temperature: 900°C

CWX500	<ul style="list-style-type: none"> ▲ Carbide, TiAlN-coated ▲ The universal carbide grade for almost all materials
DPX77S	<ul style="list-style-type: none"> ▲ TiAlN+X-coating ▲ Maximum application temperature: 900°C
DPX57S	<ul style="list-style-type: none"> ▲ TiCrN coating ▲ Maximum application temperature: 900°C

Thread types

M	Metric ISO standard thread	MF	Metric ISO fine thread	G	Whitworth thread
Tr	Metric ISO trapezoidal fine thread				

Thread flank angle

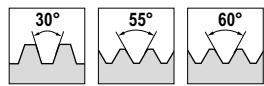

Cooling

