

FORM

Tool Supply 24/7 – New Customer Data Sheet –
Tool-O-Mat 840



Please send the completed form to info.uk.toolservice@ceratizit.com!

1 Master data

Customer No.

Invoice address

Company:

Street:

Post code / town:

Delivery address

Company:

Street:

Post code / town:

2 General data

Number of machines: Extension Unit:

Extension Unit:

Contact for Tool-O-Mat (if different – office and refilling)

Name:

E-Mail:

Telephone number:

Login type for Tool-O-Mat

via user card Piece

via personal identification number (PIN) (at least 4 digits - if possible send user list including PINs with the Form)

Customer-specific identification system¹:

¹To set up the device, two test cards and a user list with ID are required from the customer

Cost centre entry optional mandatory

additional input options

QR-Barcode reader yes no

free input via keyboard yes no

preselection via dropdown list yes no

(Send reference list, if possible together with form)

Alert delivery to customer Contact:

to Technical Sales Engineer

Invoicing daily monthly collective invoice

Withdrawal report (statistics) daily weekly monthly

E-Mail:

E-Mail:

E-Mail:

Catalogue/notifications of changes

E-Mail:

E-Mail:

E-Mail:

3 Technical Requirements – Checklist

| checked/tested | Comments |
|--|--|
| <p>Power supply European Standard 230V / 50 Hz Plug Type F (Schuko) innerhalb 1m des Automaten Standorts</p>  | |
| <p>GSM signal test</p> <p>Mobile Provider (e.g. Vodafone, EE, O2 etc.)</p> <p>Reception mode (LTE, 4G, 3G,...) No WiFi/WLAN!</p> | <p>Test with a mobile phone at the Tool-O-Mat installation site. Reception must be at least 3G!</p> <p>Please draw in signal strength!</p> |
| <p>Create a passage for the transport of the Tool-O-Mat. A pallet truck is required for transport!</p> | |

4 Technical Requirements – Dimensions

Tool-O-Mat – Main Unit

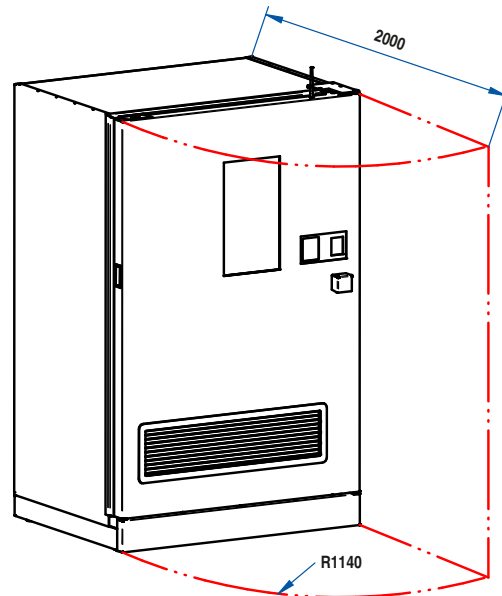
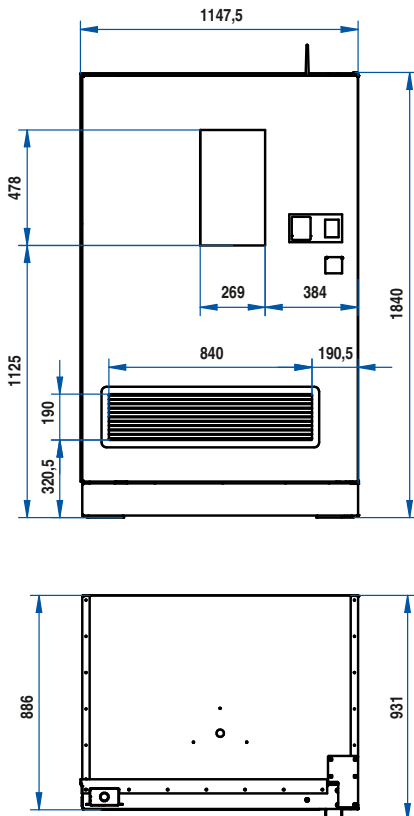

4 Technical Requirements – Dimensions

Tool-O-Mat 840 – Main Unit + Extension Unit

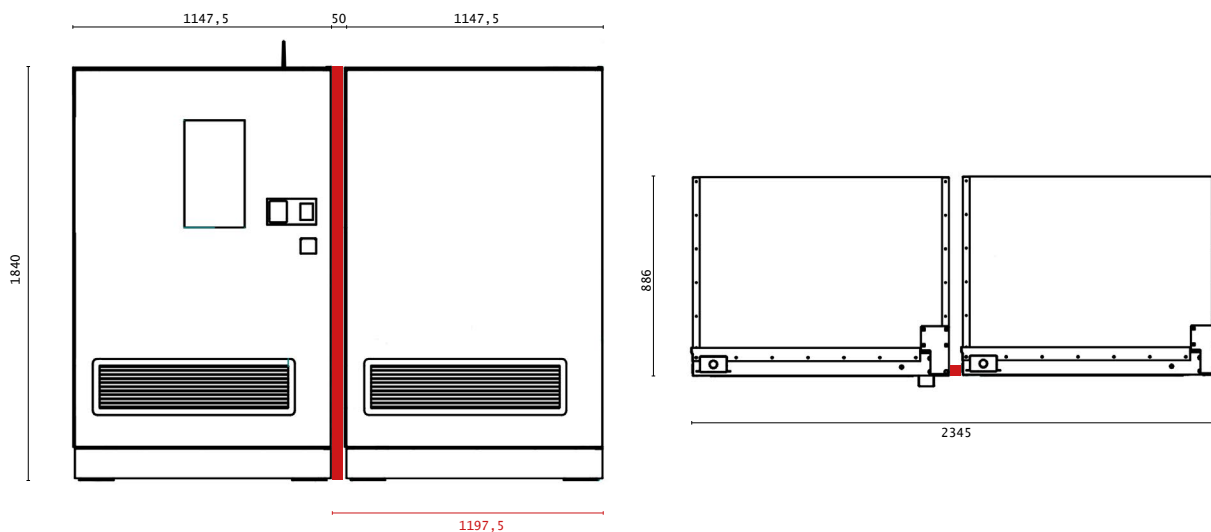

Tool-O-Mat 840 – Main Unit + Extension Unit + Extension Unit

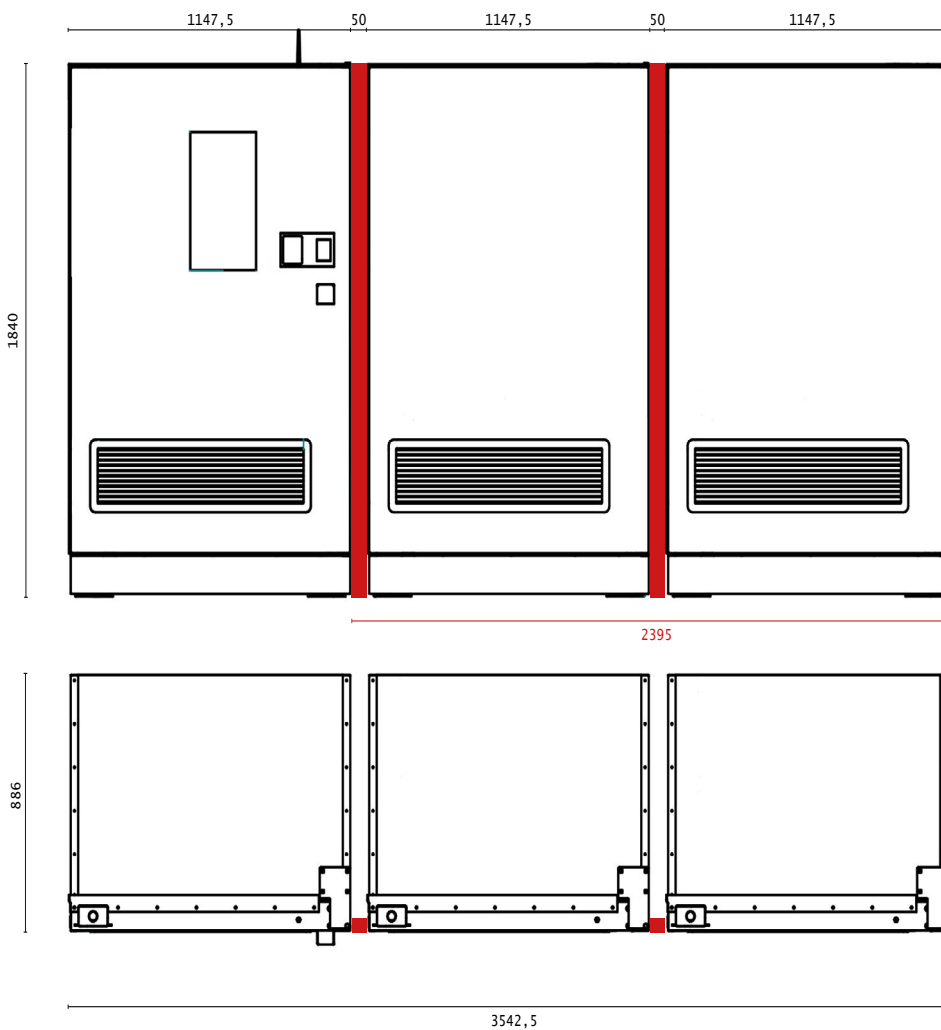

5 Front designs

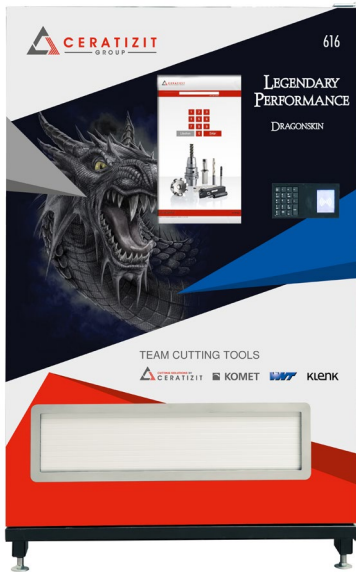

Dragonskin



AluLine



Milling Inserts



HCR1135



WTX-UNI