

FORM

Request for special tools
Special collets

Please send the completed form to Techsupport.UK@ceratizit.com!

Company:	Department:
Technical Sales Engineer:	Contact:
Customer no.:	Contact Tel. No.:
Your reference:	Contact E-Mail:

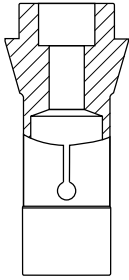

→ Page 2

Single-stepped collet

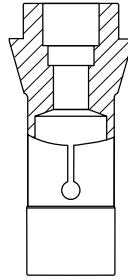

→ Page 3

Double-stepped collet

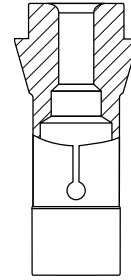

→ Page 4

Radius collet

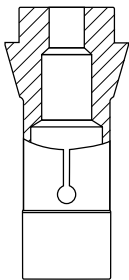

→ Page 5

Clearance bore collet

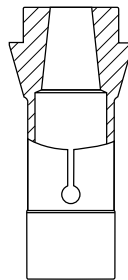

→ Page 6

Collet with increasing taper

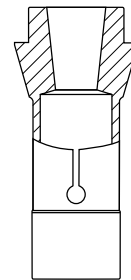

→ Page 7

Collet with decreasing taper

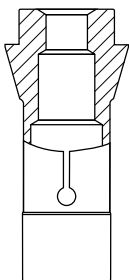

→ Page 8

Chamfer collet

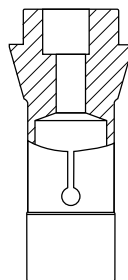

→ Page 9

Eccentric collet, central clearance bore

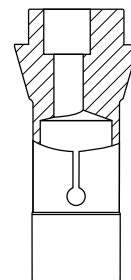

→ Page 10

Eccentric collet

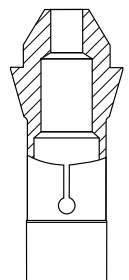

→ Page 11

Tapered stem collet

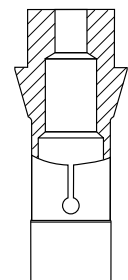

→ Page 12

Cylindrical stem collet

Single-stepped collet

1st clamping diameter D (DCONWS) =
 1st clamping length l (LSC) =
 2nd clamping length l₁ =
 Overall length L₁ (OAL) =
 2nd clamping diameter or clearance D₁ =
 Shank type & size d (DGUI) =

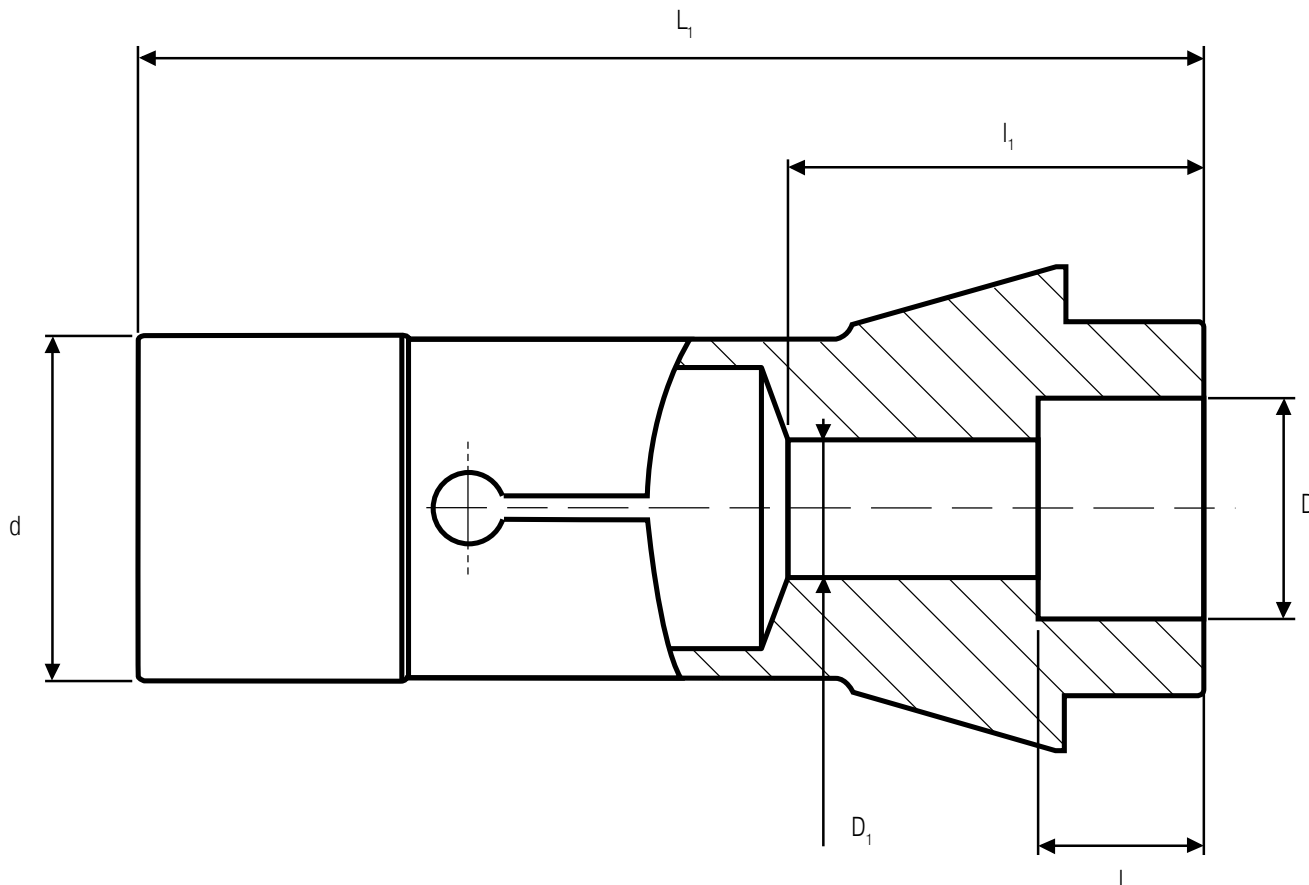

Type	Example (148E)	
HP (High Precision)	yes	
S slot	yes	
Vulcanised	yes	
Slot in cone	yes mm
Slot in shank	yes mm
Carbide coating	yes	
Undercut	yes mm

Comments

required number of pieces: Piece

Double-stepped collet

1st clamping diameter	D	(DCONWS)	=
2nd clamping diameter	D ₁		=
1st clamping length	l	(LSC)	=
2nd clamping length	l ₁		=
3rd clamping length	l ₂		=
Overall length	L ₁	(OAL)	=
3rd clamping diameter or clearance	D ₂		=
Shank type & size	d	(DGUI)	=

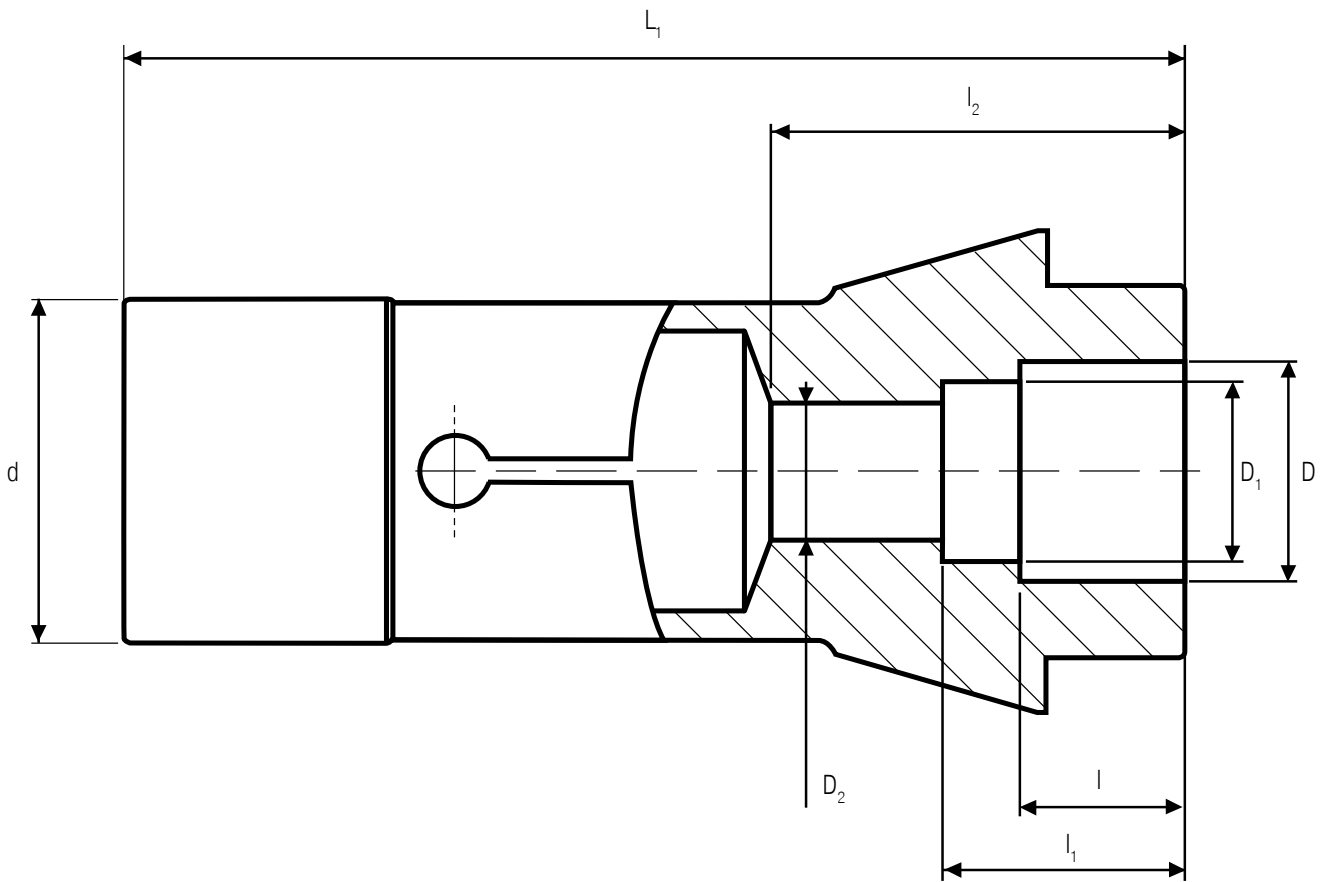

Type	Example (148E)	
HP (High Precision)	yes	
S slot	yes	
Vulcanised	yes	
Slot in cone	yes mm
Slot in shank	yes mm
Carbide coating	yes	
Undercut	yes mm

Comments

required number of pieces: Piece

Radius collet

Clamping diameter D (DCONWS) =
 Radius R =
 Clamping length l (LSC) =
 Overall length L₁ (OAL) =
 Clearance bore D₁ =
 Shank type & size d (DGUI) =

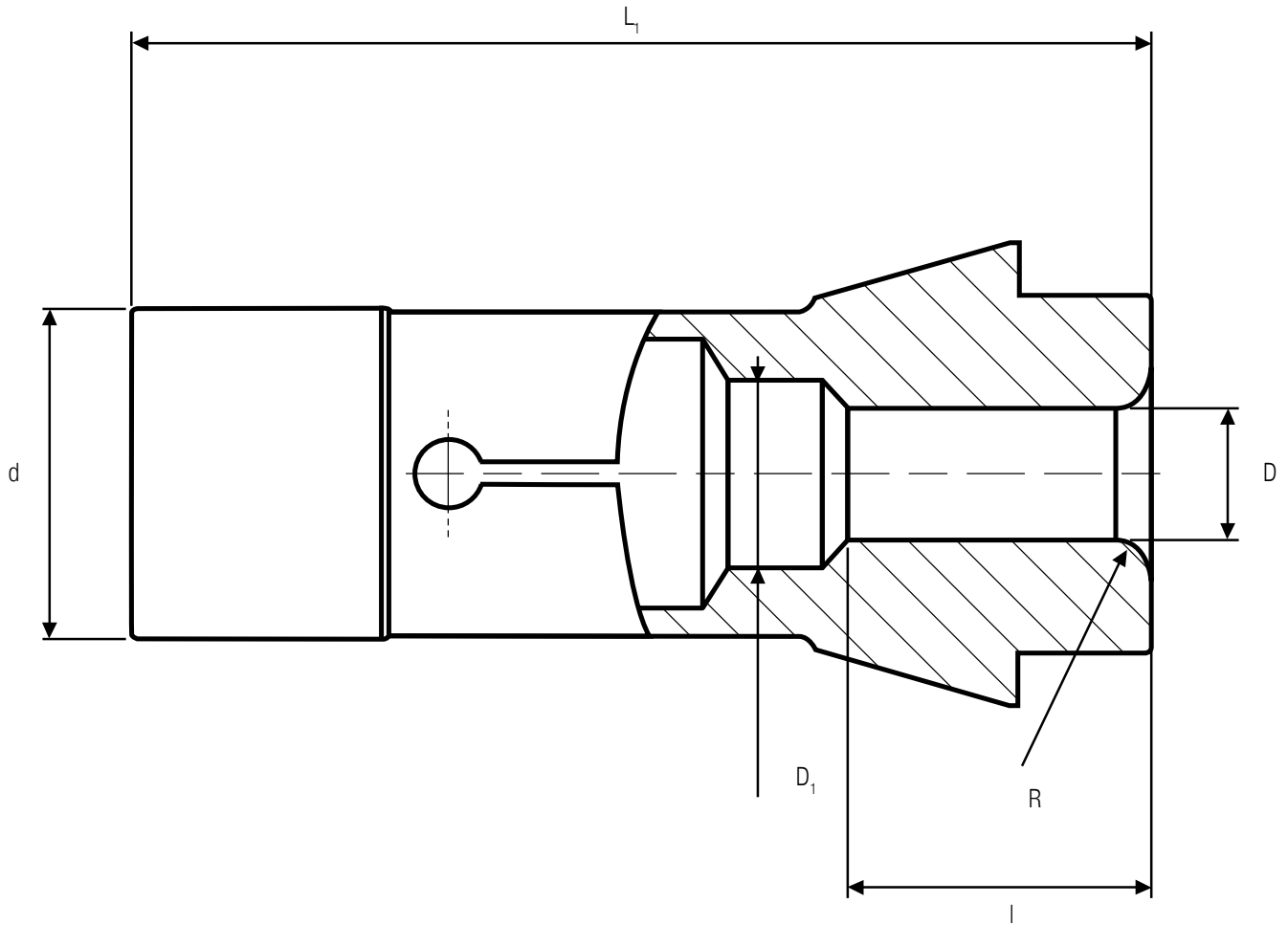

Type Example (148E)

HP (High Precision) yes
 S slot yes
 Vulcanised yes
 Slot in cone yes mm
 Slot in shank yes mm
 Carbide coating yes
 Stop yes

Comments

required number of pieces: Piece

Clearance bore collet

Clamping diameter	D	(DCONWS)	=
Clamping length	l	(LSC)	=
Overall length	L ₁	(OAL)	=
Clearance bore	D ₁		=
Shank type & size	d	(DGUI)	=

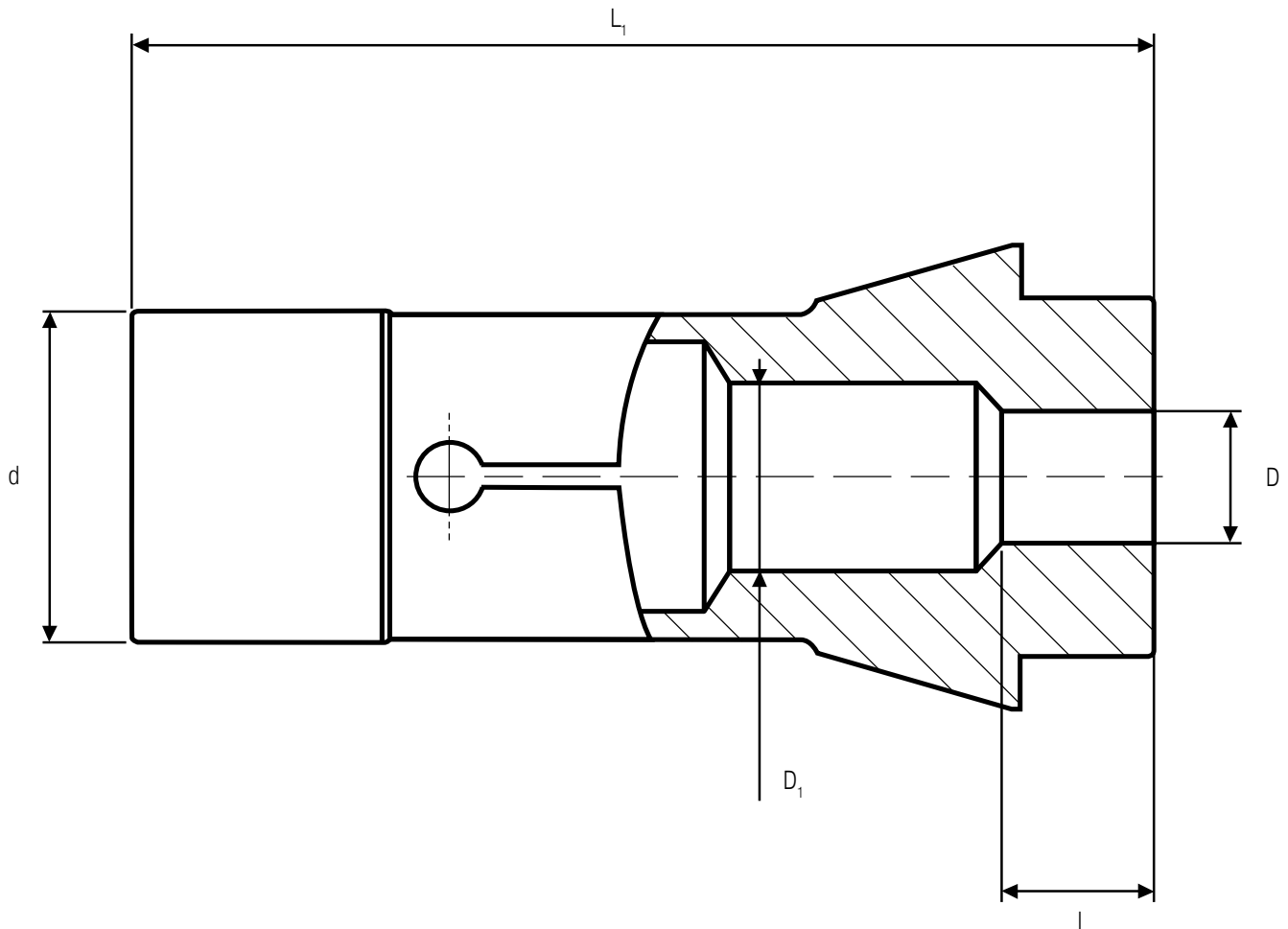

Type	Example (148E)	
HP (High Precision)	yes	
S slot	yes	
Vulcanised	yes	
Slot in cone	yes mm
Slot in shank	yes mm
Carbide coating	yes	
Stop	yes	

Comments

required number of pieces: Piece

Collet with increasing taper

Front diameter	D	(DCONWS)	=
Morse size	MK		=
Angle	β	(max. 3,5°) *	=
Clamping length	l	(LSC)	=
Overall length	L_1	(OAL)	=
Rear diameter	D_1		=
Shank type & size	d	(DGUI)	=

* depends on clamp mechanism

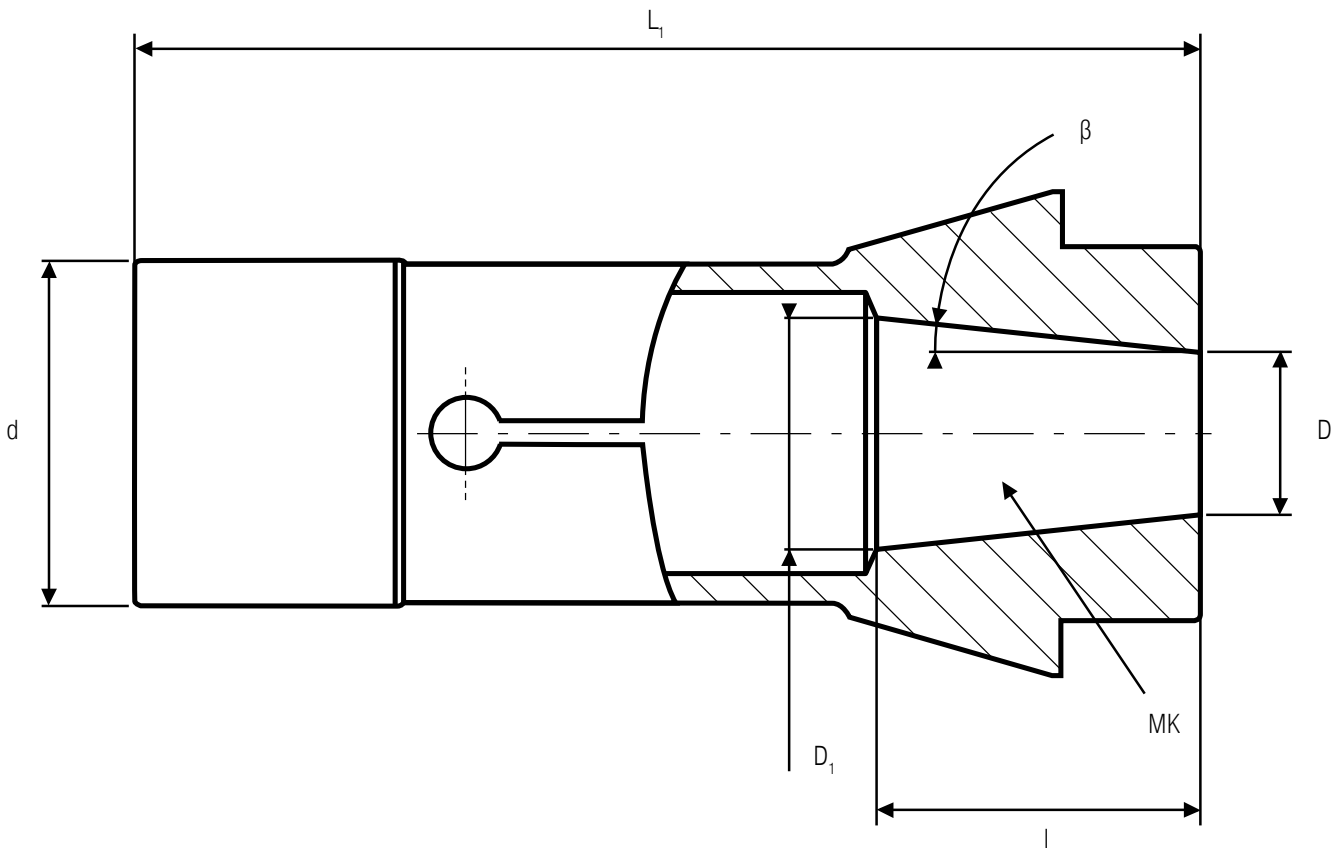

Type	Example (148E)	
HP (High Precision)	yes	
S slot	yes	
Vulcanised	yes	
Slot in cone	yes mm
Slot in shank	yes mm
Carbide coating	yes	
Stop	yes	

Comments

required number of pieces: Piece

Collet with decreasing taper

Front diameter	D	(DCONWS)	=
Morse size	MK		=
Angle	β		=
Clamping length	l	(LSC)	=
Overall length	L_1	(OAL)	=
Rear diameter	D_1		=
Shank type & size	d	(DGUI)	=

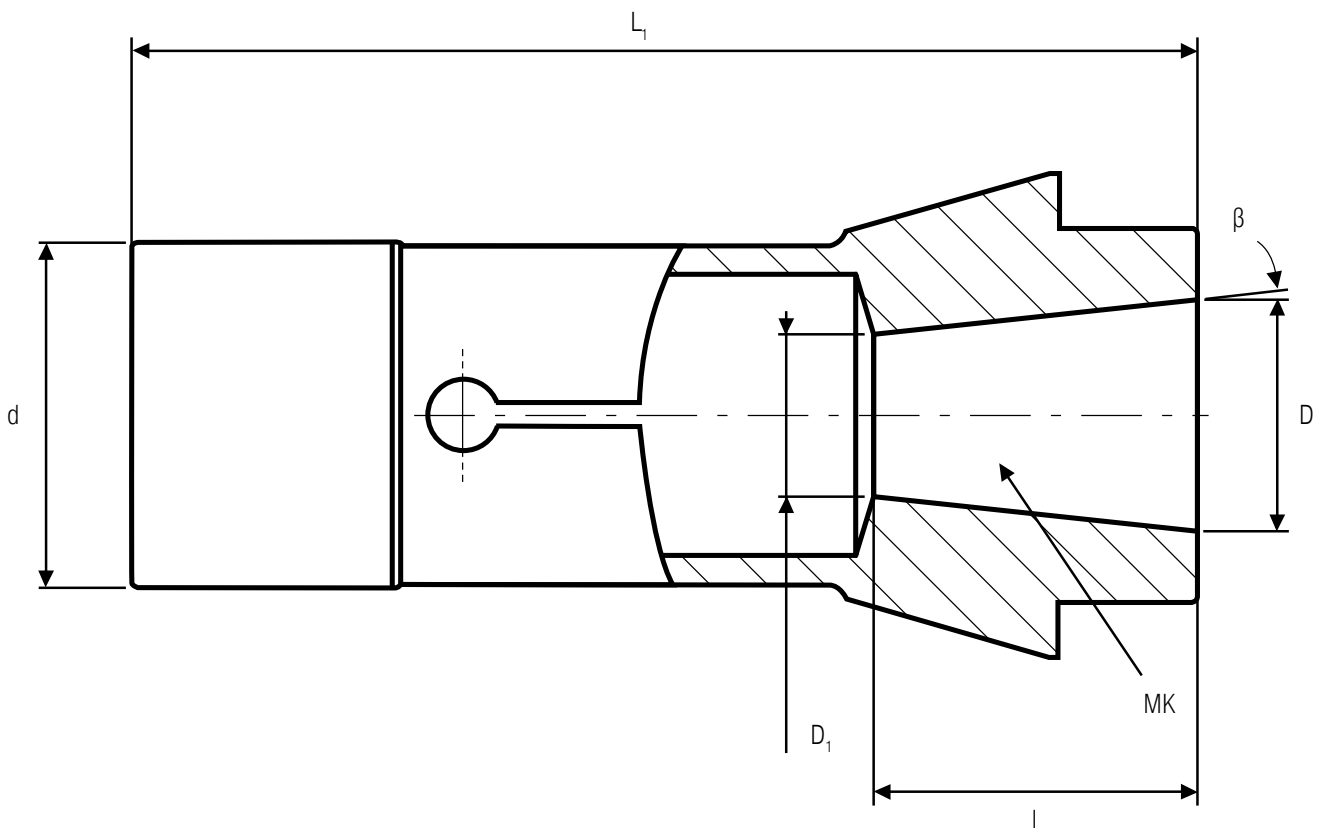

Type	Example (148E)	
HP (High Precision)	yes	
S slot	yes	
Vulcanised	yes	
Slot in cone	yes mm
Slot in shank	yes mm
Carbide coating	yes	
Stop	yes	

Comments

required number of pieces: Piece

Chamfer collet

Chamfer diameter	D_{AF}	=
Clamping Diameter	D (DCONWS)	=
Angle	γ	=
Clamping length	l (LSC)	=
Overall length	L_1 (OAL)	=
Clearance bore	D_1	=
Shank type & size	d (DGUI)	=

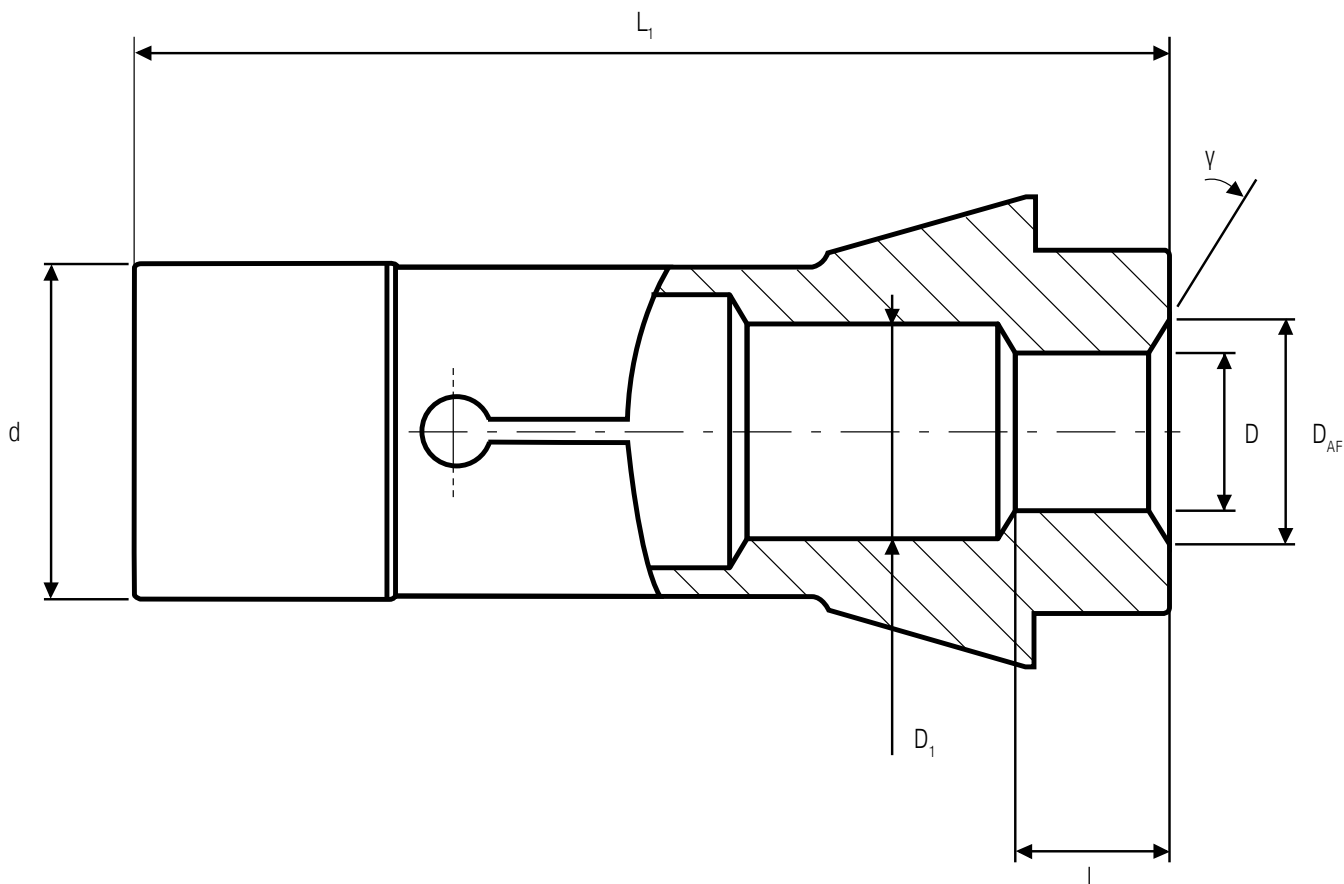

Type	Example (148E)	
HP (High Precision)	yes	
S slot	yes	
Vulcanised	yes	
Slot in cone	yes mm
Slot in shank	yes mm
Carbide coating	yes	
Stop	yes	

Comments

required number of pieces: Piece

Eccentric collet, central clearance bore

Clamping diameter	D	(DCONWS)	=
Clamping length	l	(LSC)	=
2nd clamping length	l ₂		=
Eccentric offset	x		=
Overall length	L ₁	(OAL)	=
2nd clamping diameter or clearance	D ₁		=
Shank type & size	d	(DGUI)	=

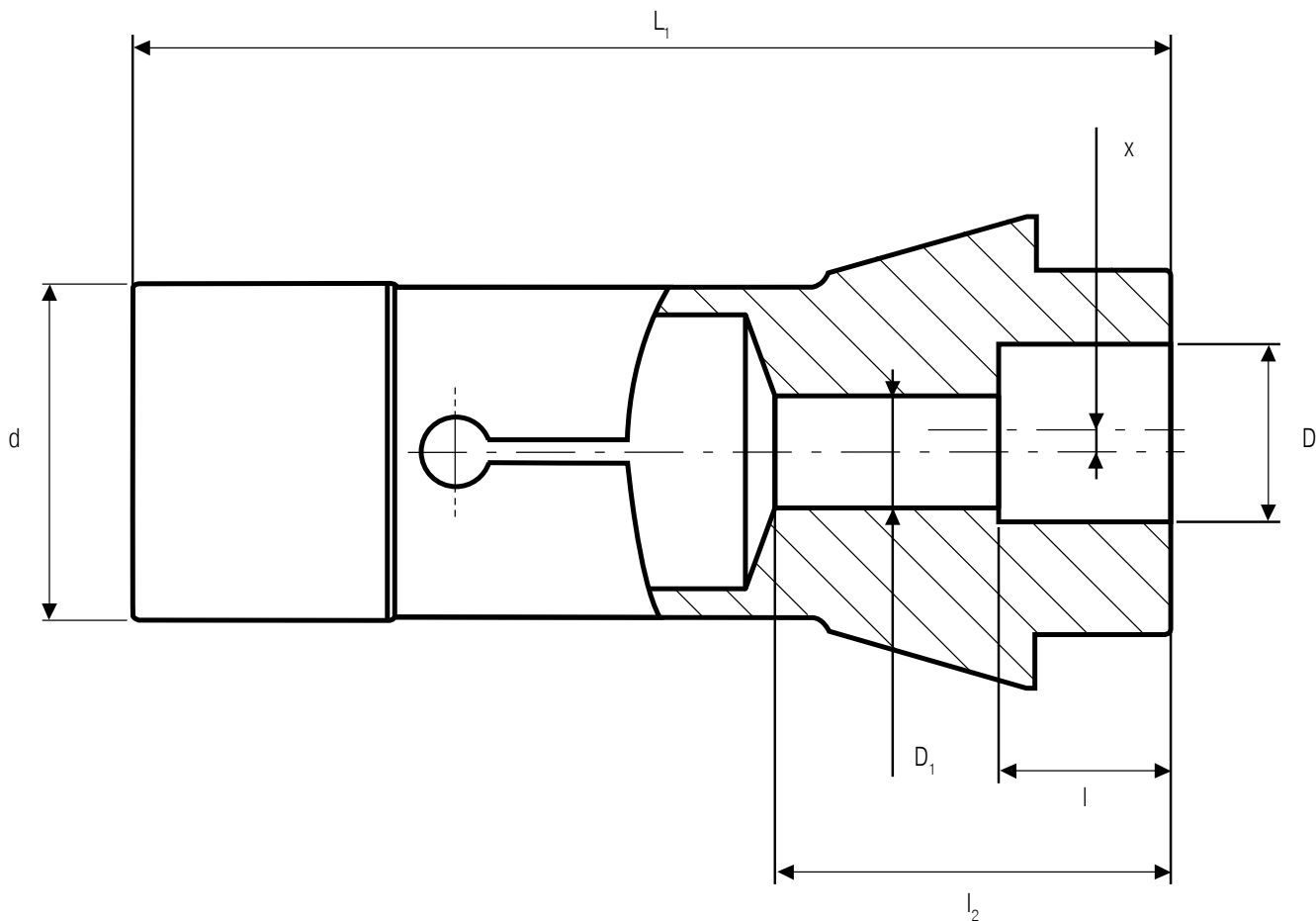

Type	Example (148E)	
HP (High Precision)	yes	
S slot	yes	
Vulcanised	yes	
Slot in cone	yes mm
Slot in shank	yes mm
Carbide coating	yes	
Undercut	yes	

Comments

required number of pieces: Piece

Eccentric collet

Clamping diameter D (DCONWS) =
 Clamping length l (LSC) =
 2nd clamping length l_2 =
 Eccentric offset x =
 Overall length L_1 (OAL) =
 2nd clamping diameter or clearance D_1 =
 Shank type & size d (DGUI) =

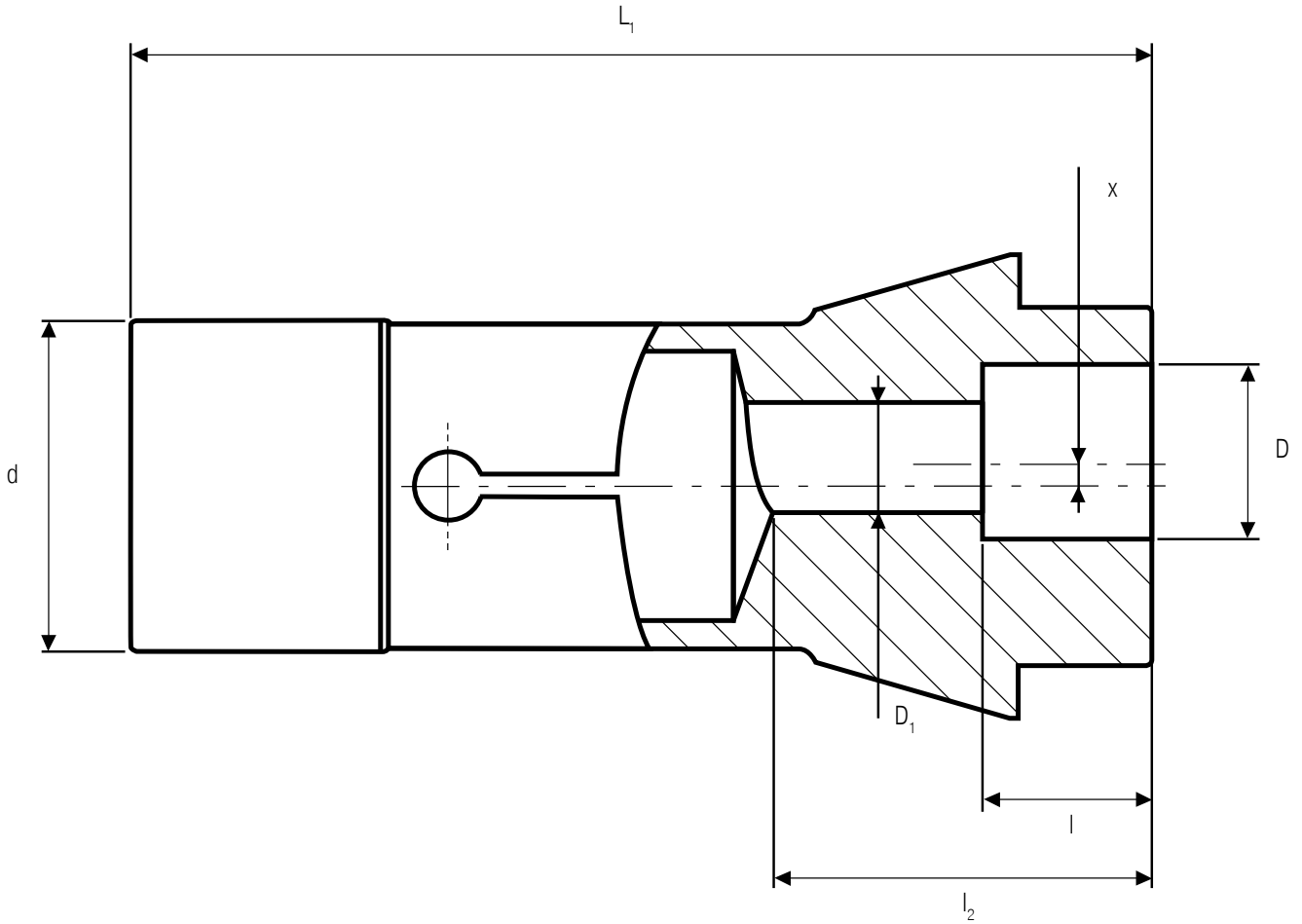

Type Example (148E)

HP (High Precision) yes
 S slot yes
 Vulcanised yes
 Slot in cone yes mm
 Slot in shank yes mm
 Carbide coating yes
 Undercut yes

Comments

required number of pieces: Piece

Tapered stem collet

Stem diameter	A	=
Clamping diameter	D (DCONWS)	=
Clamping length	l (LSC)	=
Angle	κ	=
Additional length	l ₁	=
Overall length	L ₁ (OAL)	=
Clearance bore	D ₁	=
Shank type & size	d (DGUI)	=

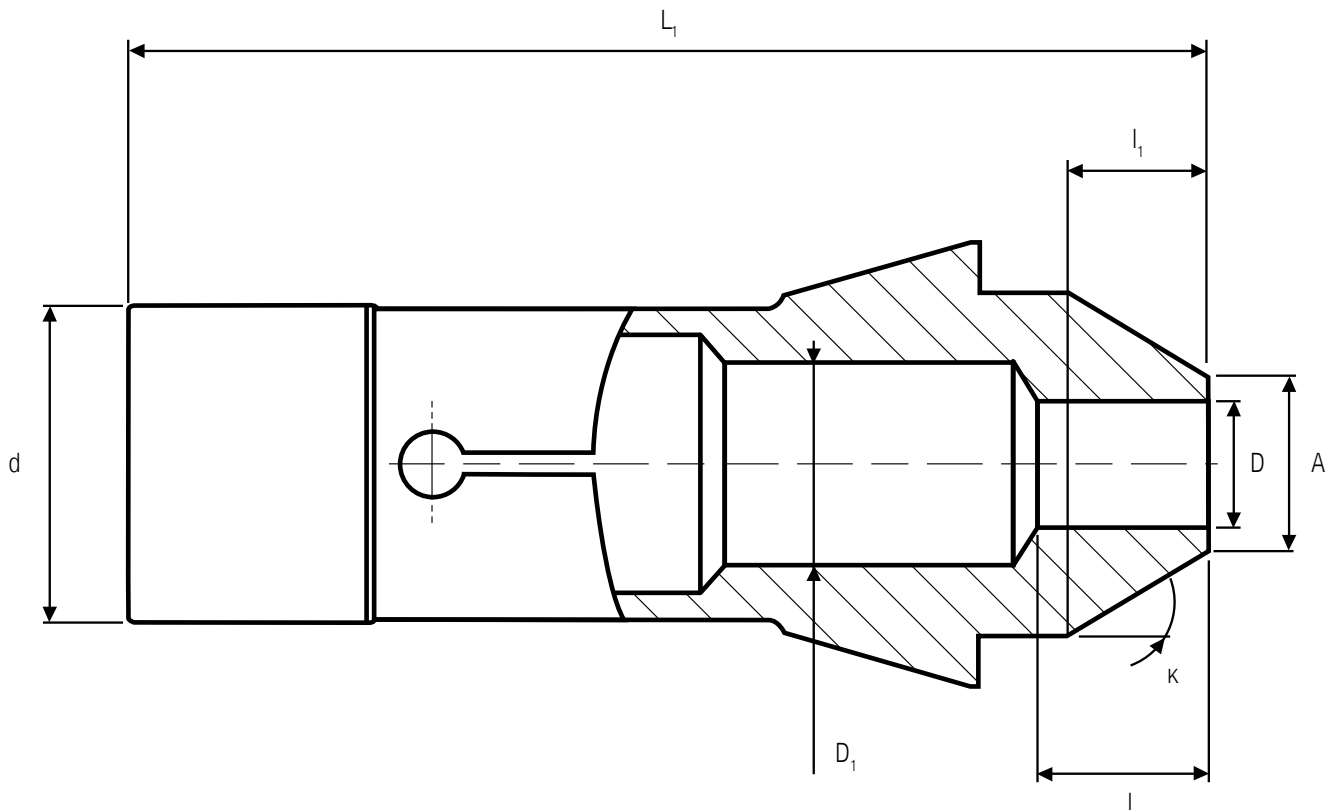

Type	Example (148E)	
HP (High Precision)	yes	
S slot	yes	
Vulcanised	yes	
Slot in cone	yes mm
Slot in shank	yes mm
Carbide coating	yes	
Stop	yes	

Comments

required number of pieces: Piece

Cylindrical stem collet

Clamping diameter D (DCONWS) =

Clamping length l (LSC) =

Additional length l_1 =

Overall length L_1 (OAL) =

Clearance bore D_1 =

Shank type & size d (DGUI) =

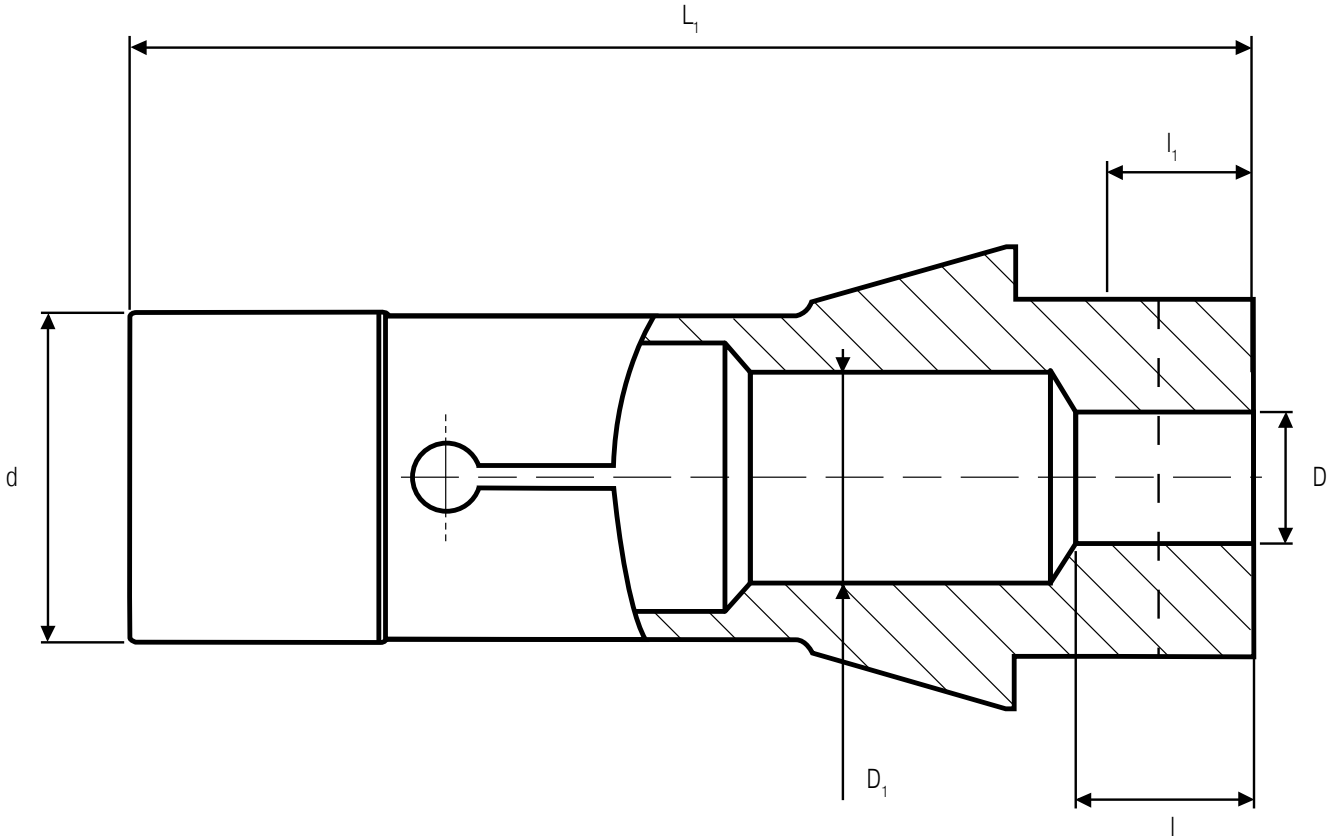

Type	Example (148E)	
HP (High Precision)	yes	
S slot	yes	
Vulcanised	yes	
Slot in cone	yes mm
Slot in shank	yes mm
Carbide coating	yes	
Stop	yes	

Comments

required number of pieces: Piece