

Form

Request for special tools Thread whirling

Please send the completed form to global.techsupport@ceratizit.com!

Company:	Department:
Technical Sales Engineer:	Contact:
Customer no.:	Contact Tel. No.:
Your reference:	Contact E-Mail:

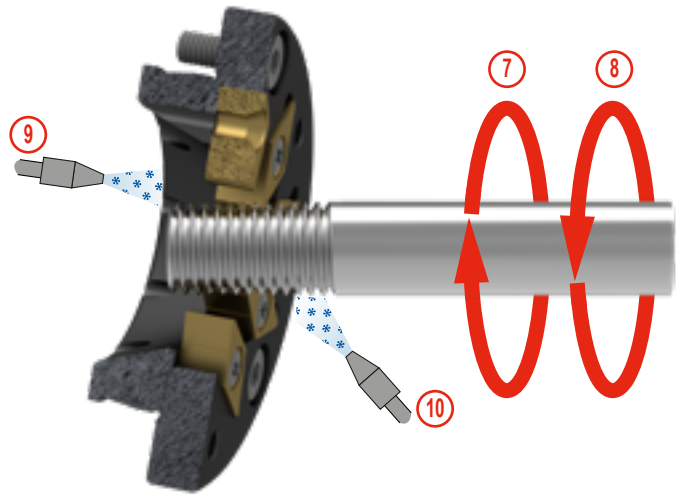
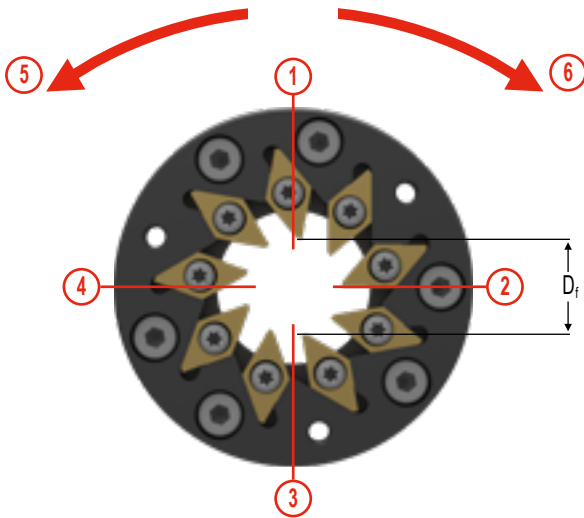

1 Material

Designation	(DIN)
Bar diameter	(\emptyset)
Bar direction of rotation	(7) (8)
Cutting position	(1) (2) (3) (4)

2 Cutting edge

Full profile
Number of threads
Coating <small>(only if expressly required)</small>

3 Tool data

Tool direction of rotation	(5) (6)
Inner cutting circle	(D _i)

4 Machine data

Manufacturer	
Machine type	
Driven tool manufacturer	
Driven tool type	
Fitted on/to (e.g. turret, carriage, other)	
Y axis (yes/no)	
Coolant pressure (bar)	
Position of coolant supply	(9) (10)

5 Comments

Please include a detailed drawing of the threaded part with this request form.